



(11) **EP 2 492 556 A1**

(12) **EUROPEAN PATENT APPLICATION**

(43) Date of publication:
29.08.2012 Bulletin 2012/35

(51) Int Cl.:
F16K 11/078 (2006.01)

(21) Application number: **12153007.5**

(22) Date of filing: **30.01.2012**

(84) Designated Contracting States:
AL AT BE BG CH CY CZ DE DK EE ES FI FR GB GR HR HU IE IS IT LI LT LU LV MC MK MT NL NO PL PT RO RS SE SI SK SM TR
Designated Extension States:
BA ME

(72) Inventor: **Cattaneo, Piero**
28010 Cavaglio d' Agogna (NO) (IT)

(74) Representative: **Cicogna, Franco**
Ufficio Internazionale Brevetti
Dott.Prof. Franco Cicogna
Via Visconti di Modrone, 14/A
20122 Milano (IT)

(30) Priority: **22.02.2011 IT MI20110263**

(71) Applicant: **Cattaneo, Piero**
28010 Cavaglio d' Agogna (NO) (IT)

(54) **High performance single control lever mixing cartridge**

(57) A high performance single control lever mixing cartridge, characterized in that said mixing cartridge comprises a holding body (1) housing at least a bottom fixed plate (4) and at least a top movable plate (3), with an indirect driving system including a driving member, said holding body (1) including side windows allowing the top movable plate (3) and driving member to exit said holding body (1), during its stroke on the end limits from the full hot water to the full cold water position.

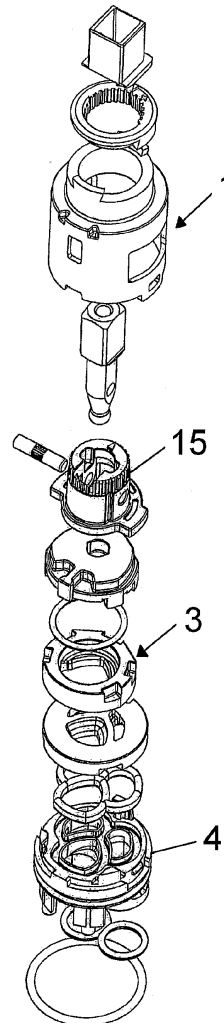

FIG. 1

EP 2 492 556 A1

Description

BACKGROUND OF THE INVENTION

[0001] The present invention relates to a high performance single control lever mixing cartridge.

[0002] As it is known, in the faucet field, mixing cartridges of a ceramic disc type for single lever controlled faucet assemblies are broadly diffused.

[0003] The above mixing cartridges have been progressively greatly improved both with respect to their reliable operation and their hydraulic and acoustic performance.

[0004] Another aspect of the technological development of the above articles is related to the reduction of their height and diameter size, from a starting conventional diameter of 47-50 mm, to a 40 mm diameter size, at present.

[0005] The same Applicant of this application has made, in 1988, a cartridge having a diameter of 35 mm and a performance equal to or greater than those of previous commercially available 40 mm diameter high performance cartridges.

[0006] In recent times, further improved mixing cartridges, of a 25 mm diameter, have been developed, which were at the start designed for some types of faucets for the USA market, for which the flow rate and noise characteristics were not of main importance.

[0007] In Europe, the above small cartridges have been also used on specifically designed hydraulic products, but with several limitations due to the low delivery flow rates and other problems related to their continuous reliable operation.

[0008] From the above mentioned 25 mm diameter small cartridges, further 28 and 30 mm diameter cartridges have been derived, allowing water to circulate both thereabout and therewithin, to provide a water outlet not only on the bottom of the faucet but also laterally for the overall height of the cartridge body.

[0009] However, these latter mixing cartridges, which are conceptually similar to the 25 mm diameter cartridges therefrom they have been derived, were affected by a comparatively low water delivery and flow rate controlling performance.

SUMMARY OF THE INVENTION

[0010] Accordingly, the aim of the present invention is to provide such a small size high performance single control lever mixing cartridge overcoming all the above mentioned problems of such prior art cartridges.

[0011] Within the scope of the above mentioned aim, a main object of the invention is to provide such a high performance single control lever mixing cartridge which provides a water flow rate larger than that provided by a prior like-size mixing cartridge.

[0012] Another object of the present invention is to provide such a high performance single control lever mixing

cartridge which may be easily made starting from easily available elements and materials and which, moreover, is very competitive from a mere economic standpoint.

[0013] Yet another object of the present invention is to provide such a high performance single control lever mixing cartridge which is very reliable and safe in operation.

[0014] According to one aspect of the present invention, the above mentioned aim and objects, as well as yet other objects, which will become more apparent hereinafter, are achieved by a high performance single control lever mixing cartridge, **characterized in that** said mixing cartridge comprises a holding body housing at least a bottom fixed plate and at least a top movable plate, with an indirect driving system including a driving member.

[0015] Said holding body comprises side windows allowing the top movable plate and driving member to exit said holding body during its stroke on the end limits from the full hot water to the full cold water position.

BRIEF DESCRIPTION OF THE DRAWINGS

[0016] Further characteristics and advantages of the present invention will become more apparent hereinafter from the following detailed disclosure of a preferred, though not exclusive, embodiment of the invention, which is illustrated, by way of an indicative, but not limitative, example in the accompanying drawings, where:

Figure 1 is an exploded perspective view of the high performance single control lever mixing cartridge according to the present invention;

Figure 2 is a further perspective view of the holding body of the inventive mixing cartridge;

Figure 3 is yet another perspective view of a bottom fixed plate included in the mixing cartridge according to the present invention;

Figure 4 is yet another perspective view showing a clamping of the bottom plate;

Figure 5 is yet another perspective view showing a movable plate included in the inventive mixing cartridge;

Figure 6 is yet another perspective view showing a support for a rod element of the inventive mixing cartridge;

Figure 7 is yet another perspective view showing the cartridge holding body and a rod rotary pin element;

Figure 8 is yet another perspective view showing an embodiment of the mixing cartridge with a mixing cartridge holding body in which water is circulated under a raised bottom;

Figure 9 is yet another perspective view showing a further embodiment of the inventive mixing cartridge with a holding body being sealed at a top collar thereof; and

Figure 10 is yet another perspective view showing an adapter for raising water of the cartridge embodiment shown in figure 8.

DESCRIPTION OF THE PREFERRED EMBODIMENTS

[0017] With reference to the number references of the above mentioned figures, the high performance single control lever mixing cartridge according to the present invention is preferably of the so-called "closure position idle type", that is of a type in which the top plate is driven by an indirect driving system, to provide improved operating performance.

[0018] In order to maximize the useful movement area or field of the top plate, through the holding body 1 of the mixing cartridge have been formed side windows 2, allowing the top movable plate 3 and driving member 14 to exit said holding body 1, during its stroke on the end limits from the fully hot water to the fully cold water position thereof.

[0019] Said side windows 2 are designed exclusively for allowing a larger displacement and size of the movable plate, differently from similar windows of some prior articles allowing only a lateral outflow of the mixed water.

[0020] Figure 3 shows the top plate 4 which is clamped or coupled, through two rear blind not throughgoing rear recesses 7, to latching elements 5 on a plastics material 6, as shown in figure 4.

[0021] To achieve an improved high pressure sealing, the fixed plate, shown in figure 3, comprises, on a bottom side thereof, a plurality of slots 8 for engaging therein, in a partially recessed position, an inner sealing gasket.

[0022] In this connection it should be pointed out that the above type of construction has never been used on a small size structure as that disclosed by the present invention.

[0023] As shown in figure 5, the movable plate 3 is so contoured as to maximize the hydraulic performance of the mixing cartridge.

[0024] More specifically, the movable plate 3 comprises a specifically designed profile 9, of a substantially triangular contour, with convex sides and being characterized by the provision of two side outlet or supplementary lugs 10.

[0025] This configuration is present both in the embodiment in which the plate has an open cavity and in the embodiment in which said plate has a blind cavity or hollow.

[0026] As shown in figure 2, the holding body 1 comprises, at the top portion thereof, two detent elements 11, having substantially a reversed trapezoidal configuration, and a contour mating a contour of corresponding detent elements 12 provided on a temperature limiting ring nut member 13.

[0027] This construction prevents the ring nut member from accidentally disengaging as its two slanted or inclined planes abut against the respective detent portions of the holding body.

[0028] As shown, said cartridge further comprises a cartridge rod 15, shown in figure 6, supported by a support element including a double abutment of the lugs 16

on rotary detent members provided inside said holding body 1, to increase the detent element efficiency.

[0029] If necessary, the strength of said detent elements may be enhanced by a rod rotary pin 18, shown in figure 7, having such a length as to bear on end portions of dedicated elongated holes 17, formed in the collar of the holding body 1, as a fully leftward or rightward rotary movement is carried out.

[0030] In an embodiment of the inventive cartridge, wherein water is circulated under the raised bottom 6, and as shown in figures 4 and 8, a diametral housing for an O-ring element is provided, thereby allowing a faucet tightness seat to have a diameter larger than that of the cartridge, contrarily to the prior art which provides an opposite construction.

[0031] The above disclosed feature allows to assemble on this cartridge embodiment a water raising adapter, either with an outer sealing on its larger diameter 19, as shown in figures 8 and 10, or a simple or double sealing on the top collar 20, as shown in figure 9, or any other suitable configurations as required.

[0032] The above approach allows to bring mixed water to a mixed water outlet arranged at a height as greater as possible, while preventing water from entering the cartridge mechanism, since it is insulated by the inner O-ring assembled as disclosed.

[0033] This solution, moreover, makes the inventive cartridge most suitable for meeting at present novel faucet designs.

[0034] In this connection it should be pointed out that, though on the market apparently analogous products are available, in these products the mixing cartridge, however, is engaged from the top side and not from the bottom side as taught by the present invention, thereby it is not possible to achieve the miniaturized size which may be achieved by the two disclosed embodiments of the present invention.

[0035] The greater diameter adapter 19 sealing is performed on the faucet body, not shown in the figures.

[0036] The sealing of the adapter 20 on the collar is performed inside the cartridge clamping ring nut, said ring nut including an outer gasket providing a sealing coupling on the faucet body.

[0037] According to a further aspect of the present invention, the water raising adapters may comprise inner projections 22, as shown in figure 10, adapted to be engaged in corresponding cavities 21 formed on the holding body 1 top plane.

[0038] This feature, shown in figure 2, allows to provide a snug orienting and prevents any rotary movement with respect to the holding body.

[0039] It has been found that the invention fully achieves the intended aim and objects.

[0040] In fact, the invention has provided a "miniaturized" single control lever mixing cartridge, free of the above disclosed drawbacks of similar prior mixing cartridges.

[0041] The inventive mixing cartridge provides opti-

mum performance with respect to its reliable operation, and a maximum freedom in selecting the faucet product thereinto said cartridge will be installed.

[0042] The most advantageous features of the present invention, which allow to achieve a very great increase of the hydraulic performance thereof, consist, at first, of the side windows of the holding body allowing a larger movement than that permitted by a closed holding body.

[0043] Another very important feature is the provision of rear blind latching elements for clamping the fixed plate providing an enhanced useful area.

[0044] Moreover, also the top movable plate profile with the two side projections or rear enlarged portions is a very important constructional feature.

[0045] Yet another very important aspect of the present invention is the possibility of providing the cartridge, in a long bottom embodiment thereof, with a socket element allowing water to achieve an enhanced height.

[0046] In fact, as the socket is introduced in the cartridge from above, it allows to further reduce the size while permitting water to achieve greater height, up to the collar, the starting cartridge size being the same.

[0047] In practicing the invention, the used materials, as well as the contingent size and shapes, can be any, depending on requirements.

Claims

1. A high performance single control lever mixing cartridge, **characterized in that** said mixing cartridge comprises a holding body housing at least a bottom fixed plate and at least a top movable plate, with an indirect driving system including a driving member, said holding body including side windows allowing the top movable plate and driving member to exit said holding body, during its stroke on the end limits from the full hot water to the full cold water position.
2. A single control lever mixing cartridge, according to claim 1, **characterized in that** said bottom plate is coupled through two rear blind not throughgoing rear recesses to latching elements arranged on a fixed support.
3. A single control lever mixing cartridge, according to claim 2, **characterized in that** said fixed plate comprises on a bottom side thereof a plurality of slots for engaging therein, in a partially recessed position, an inner sealing gasket.
4. A single control lever mixing cartridge, according to claim 1, **characterized in that** said movable plate comprises a port having a substantially triangular contour with convex sides, and including two side outlets or supplementary lugs, said contour being provided both in an open hollow type of plate and in a blind hollow type of plate.
5. A single control lever mixing cartridge, according to claim 1, **characterized in that** said holding body comprises, at a top portion thereof, two detent elements having substantially a reversed trapezoidal configuration and a contour mating a contour of corresponding detent elements provided on a temperature limiting ring nut member.
6. A single control lever mixing cartridge, according to claim 1, **characterized in that** said cartridge comprises a cartridge rod supported by a support element including a double abutment for simultaneously abutting thereon lug elements on rotary detent members provided inside said holding body to increase the detent element efficiency, the detent element strength being increased by a rotary pin of the rod, having such a length as to bear on end portions of dedicated elongated holes formed in a collar of the holding body, as a full leftward or rightward rotary movement is carried out.
7. A single control lever mixing cartridge, according to claim 1, **characterized in that** said cartridge comprises, under a raised base thereof, a water circulating path and a diametral housing for an OR element, thereby allowing a faucet tightness seat to have a diameter larger than that of a cartridge diameter.
8. A single control lever mixing cartridge, according to claim 1, **characterized in that** said cartridge comprises a water raising adapter, either with an outer sealing on its larger diameter or a simple or double sealing on the top collar or any other suitable configurations.
9. A single control lever mixing cartridge, according to claim 1, **characterized in that** said greater diameter adapter sealing is performed on the faucet body, the collar adapter sealing being performed inside the cartridge clamping ring nut, said ring nut including an outer gasket providing a sealing coupling on the faucet body.
10. A single control lever mixing cartridge, according to claim 1, **characterized in that** the water raising adapter comprises inner projections adapted to be engaged in corresponding cavities formed on the holding body top plane, to provide a snug orienting and prevent any rotary movement with respect to said holding body.

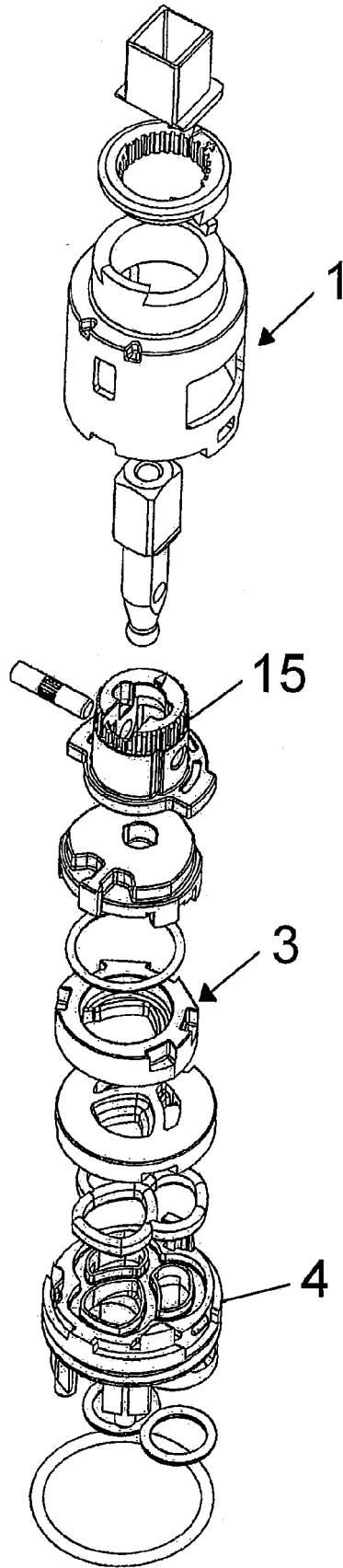

FIG. 1

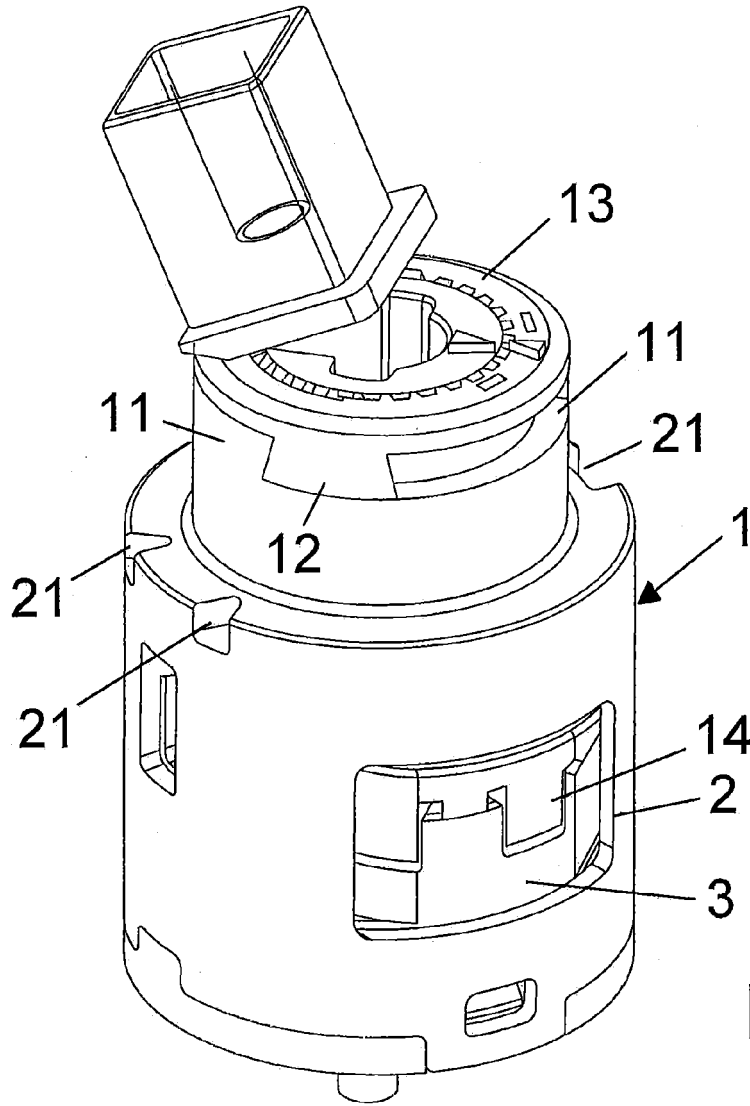

FIG. 2

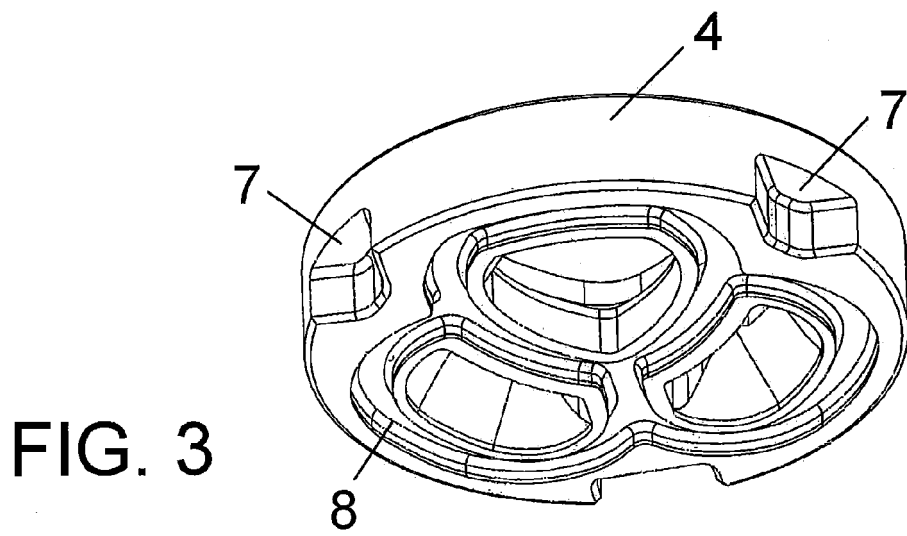

FIG. 3

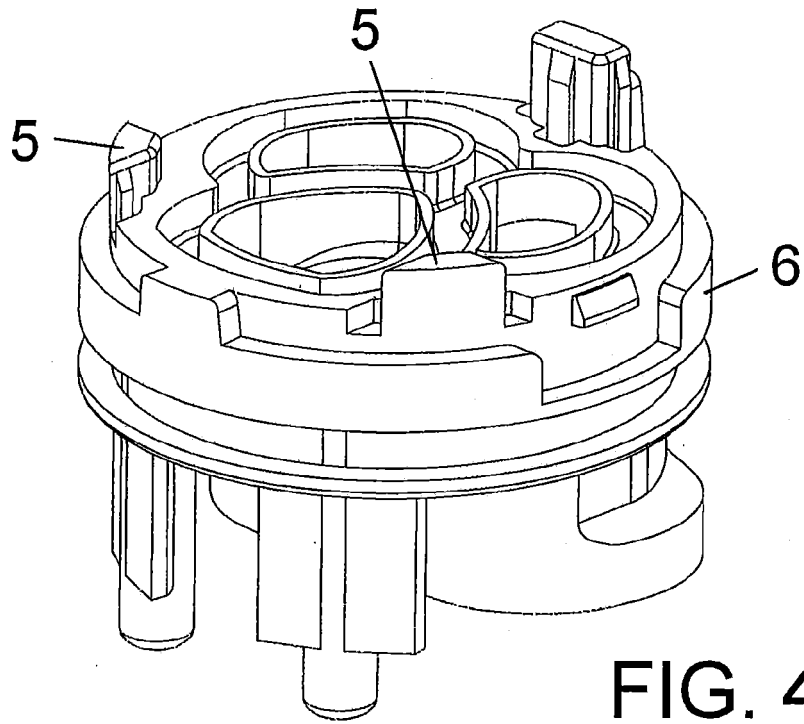

FIG. 4

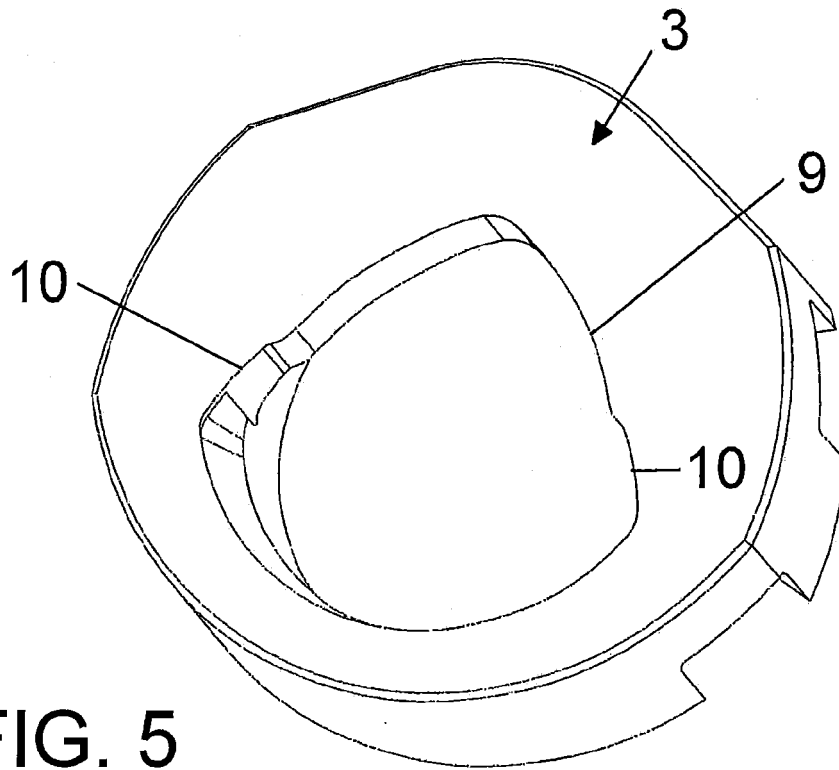

FIG. 5

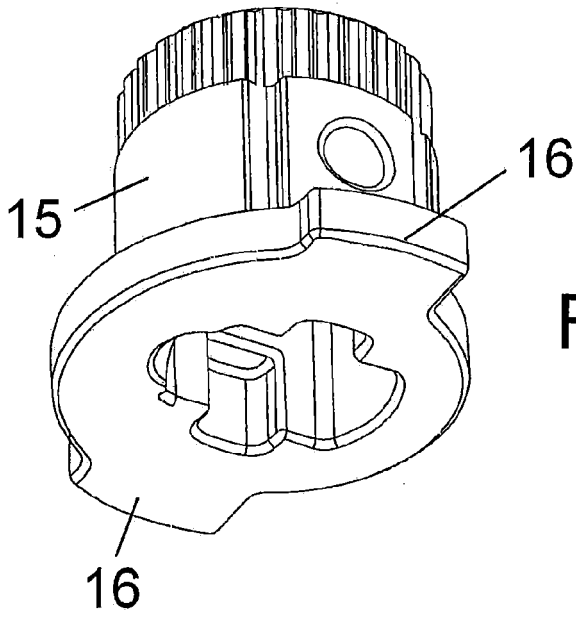

FIG. 6

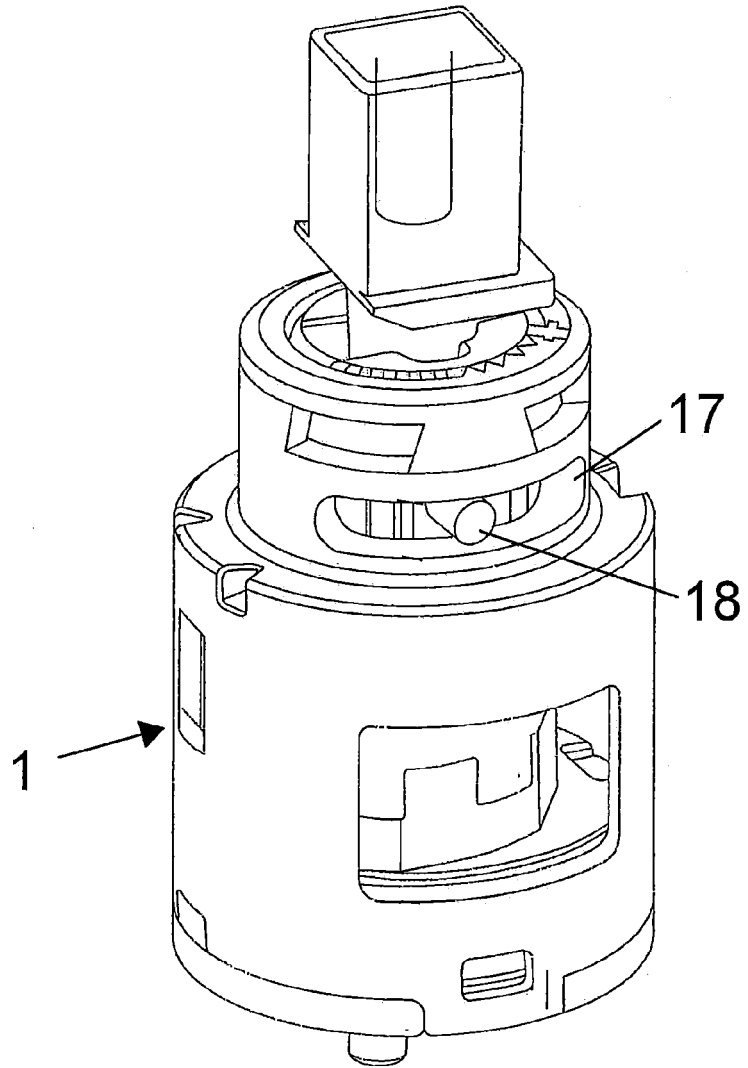

FIG. 7

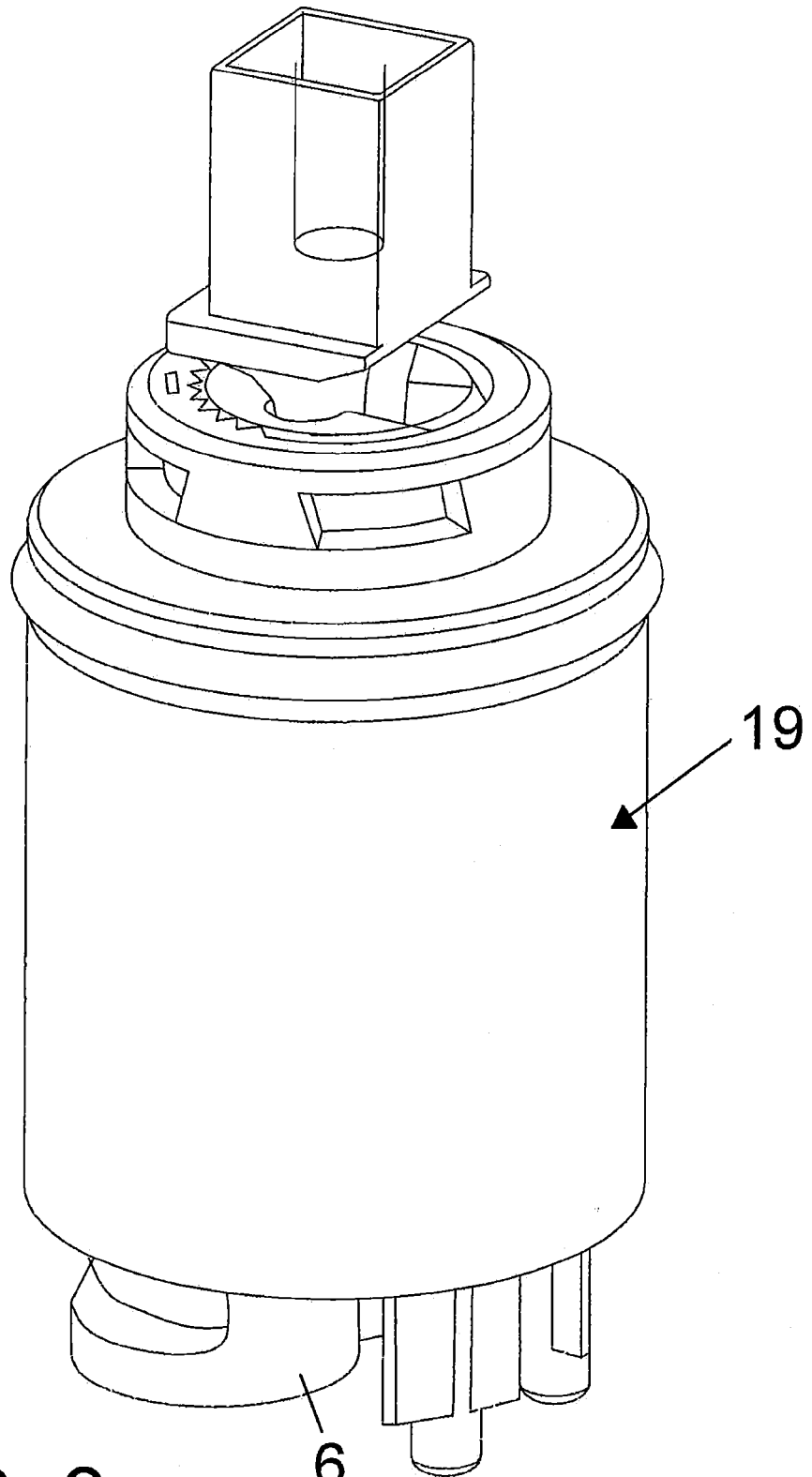

FIG. 8

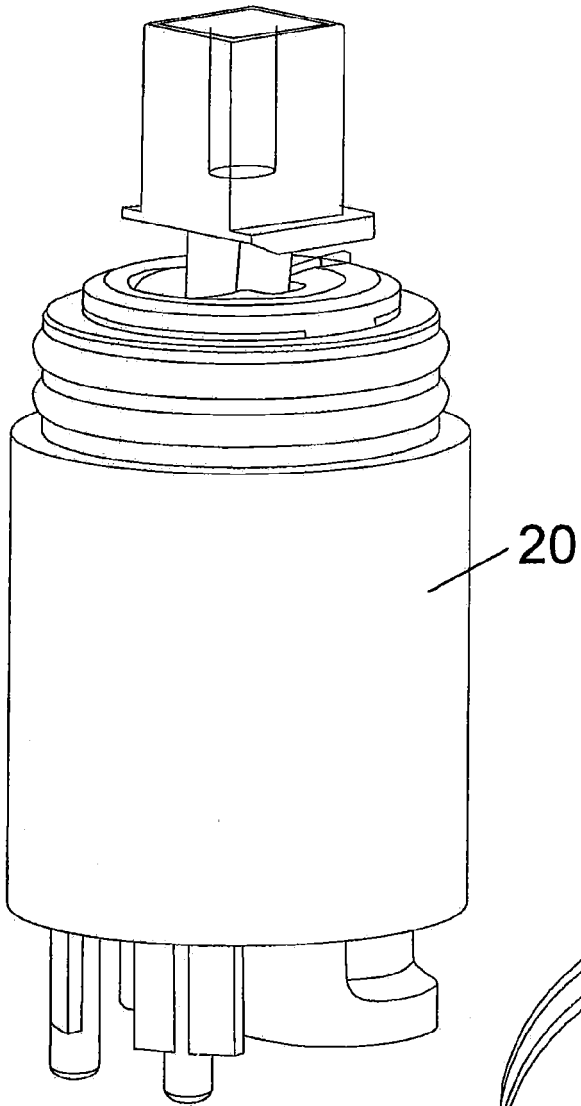

FIG. 9

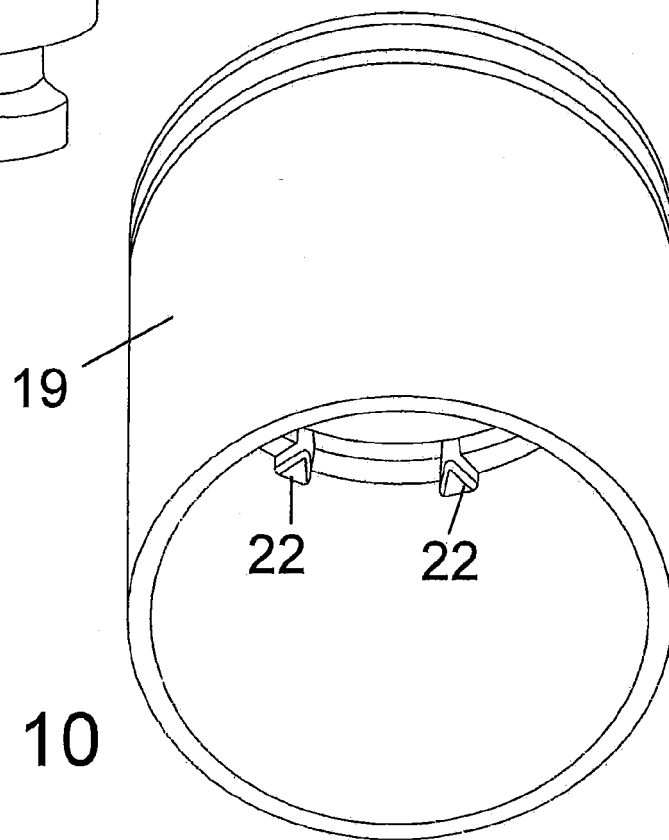

FIG. 10



EUROPEAN SEARCH REPORT

Application Number
EP 12 15 3007

DOCUMENTS CONSIDERED TO BE RELEVANT			
Category	Citation of document with indication, where appropriate, of relevant passages	Relevant to claim	CLASSIFICATION OF THE APPLICATION (IPC)
X	US 2009/242051 A1 (XINLU LAN [CN] ET AL) 1 October 2009 (2009-10-01) * abstract; figure 1 *	1-10	INV. F16K11/078
X	US 6 032 686 A (O'HARA ROBERT P [US] ET AL) 7 March 2000 (2000-03-07) * abstract; figures 2-4,8 *	1	
X	US 2004/084097 A1 (BLOOM MARK S [US] ET AL) 6 May 2004 (2004-05-06) * abstract; figures 2,3 *	1	
X	US 2009/090414 A1 (DI NUNZIO DAVID [US]) 9 April 2009 (2009-04-09) * abstract; figure 1 *	1	
			TECHNICAL FIELDS SEARCHED (IPC)
			F16K
The present search report has been drawn up for all claims			
Place of search Munich		Date of completion of the search 19 March 2012	Examiner Podratzky, Andreas
CATEGORY OF CITED DOCUMENTS		T : theory or principle underlying the invention E : earlier patent document, but published on, or after the filing date D : document cited in the application L : document cited for other reasons & : member of the same patent family, corresponding document	
X : particularly relevant if taken alone Y : particularly relevant if combined with another document of the same category A : technological background O : non-written disclosure P : intermediate document			

1
EPO FORM 1503 03.02 (F04C01)

ANNEX TO THE EUROPEAN SEARCH REPORT
ON EUROPEAN PATENT APPLICATION NO.

EP 12 15 3007

This annex lists the patent family members relating to the patent documents cited in the above-mentioned European search report. The members are as contained in the European Patent Office EDP file on
The European Patent Office is in no way liable for these particulars which are merely given for the purpose of information.

19-03-2012

Patent document cited in search report	Publication date	Patent family member(s)	Publication date
US 2009242051 A1	01-10-2009	NONE	

US 6032686 A	07-03-2000	CA 2226824 A1	09-07-1998
		EP 0853207 A2	15-07-1998
		US 5839464 A	24-11-1998
		US 6032686 A	07-03-2000

US 2004084097 A1	06-05-2004	NONE	

US 2009090414 A1	09-04-2009	US 2009090414 A1	09-04-2009
		WO 2009046242 A1	09-04-2009
