



US 20150018821A1

(19) **United States**

(12) **Patent Application Publication**

Zarins et al.

(10) **Pub. No.: US 2015/0018821 A1**

(43) **Pub. Date: Jan. 15, 2015**

(54) **METHODS AND APPARATUS FOR INTRAVASCULARLY-INDUCED NEUROMODULATION**

Publication Classification

(71) Applicant: **Medtronic Ardian Luxembourg S.a.r.l.**, Luxembourg (LU)

(51) **Int. Cl.**
A61B 18/14 (2006.01)
A61B 17/12 (2006.01)

(72) Inventors: **Denise Zarins**, Saratoga, CA (US);
Nicolas Zadno, Fremont, CA (US);
Benjamin J. Clark, Redwood City, CA (US);
Erik Thai, Mountain View, CA (US)

(52) **U.S. Cl.**
CPC *A61B 18/1492* (2013.01); *A61B 17/12136* (2013.01); *A61B 2018/00083* (2013.01)
USPC **606/41**

(21) Appl. No.: **14/335,016**

(57) **ABSTRACT**

(22) Filed: **Jul. 18, 2014**

Methods and apparatus are provided for intravascularly-induced neuromodulation using a pulsed electric field, e.g., to effectuate irreversible electroporation or electrofusion, necrosis and/or induction of apoptosis, alteration of gene expression, changes in cytokine upregulation, etc., in target neural fibers. In some embodiments, the intravascular PEF system comprises a catheter having a pair of bipolar electrodes for delivering the PEF, with a first electrode positioned on a first side of an impedance-altering element and a second electrode positioned on an opposing side of the impedance-altering element. A length of the electrodes, as well as a separation distance between the first and second electrodes, may be specified such that, with the impedance-altering element deployed in a manner that locally increases impedance within a patient's vessel, e.g., with the impedance-altering element deployed into contact with the vessel wall at a treatment site within the patient's vasculature, a magnitude of applied voltage delivered across the bipolar electrodes necessary to achieve desired neuromodulation is reduced relative to an intravascular PEF system having similarly spaced electrodes but no (or an undeployed) impedance-altering element. In a preferred embodiment, the impedance-altering element comprises an inflatable balloon configured to locally increase impedance within a patient's vasculature. The methods and apparatus of the present invention may be used to modulate a neural fiber that contributes to renal function.

Related U.S. Application Data

(60) Continuation of application No. 13/934,133, filed on Jul. 2, 2013, now Pat. No. 8,818,514, which is a continuation of application No. 12/827,700, filed on Jun. 30, 2010, now abandoned, which is a division of application No. 11/266,993, filed on Nov. 4, 2005, now Pat. No. 7,756,583, which is a continuation-in-part of application No. 11/129,765, filed on May 13, 2005, now Pat. No. 7,653,438, said application No. 11/266,993 is a continuation-in-part of application No. 10/408,665, filed on Apr. 8, 2003, now Pat. No. 7,162,303, said application No. 11/266,993 is a continuation-in-part of application No. 11/189,563, filed on Jul. 25, 2005, now Pat. No. 8,145,316.

(60) Provisional application No. 60/616,254, filed on Oct. 5, 2004, provisional application No. 60/624,793, filed on Nov. 2, 2004, provisional application No. 60/442,970, filed on Jan. 29, 2003, provisional application No. 60/415,575, filed on Oct. 3, 2002, provisional application No. 60/370,190, filed on Apr. 8, 2002.

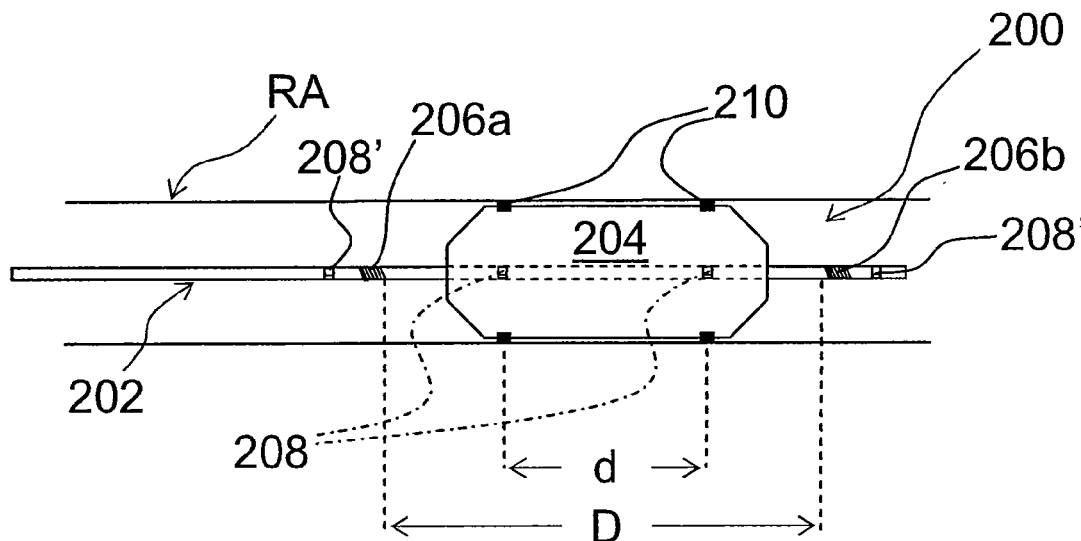

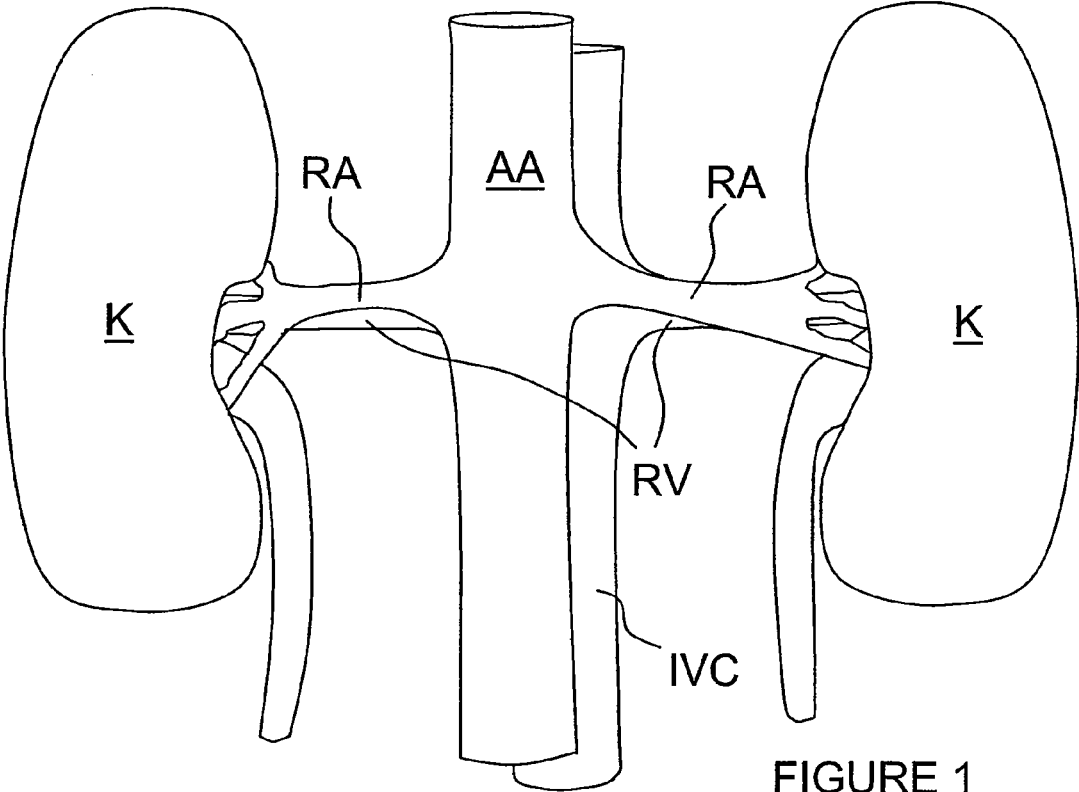
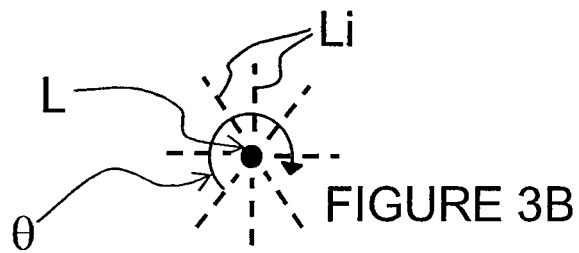
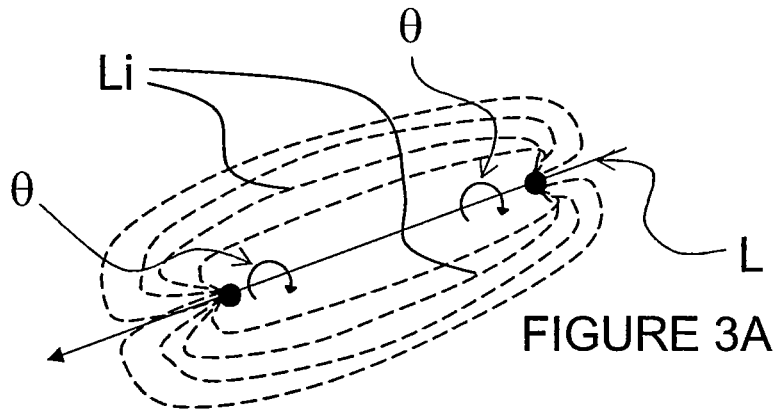
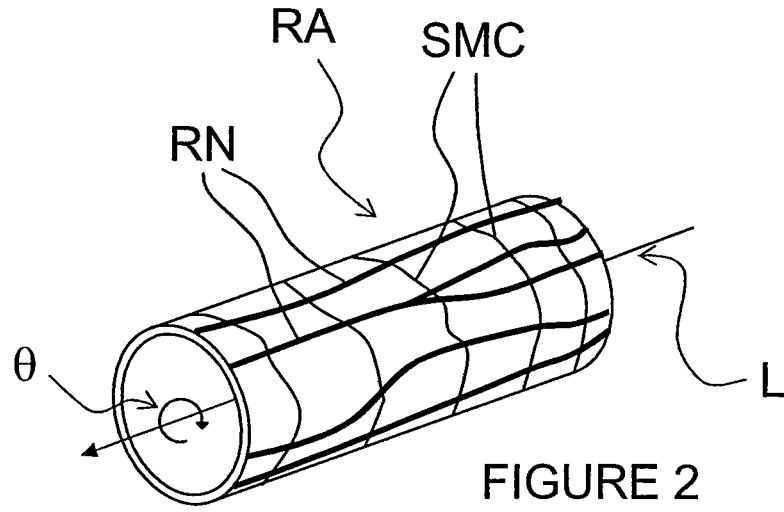
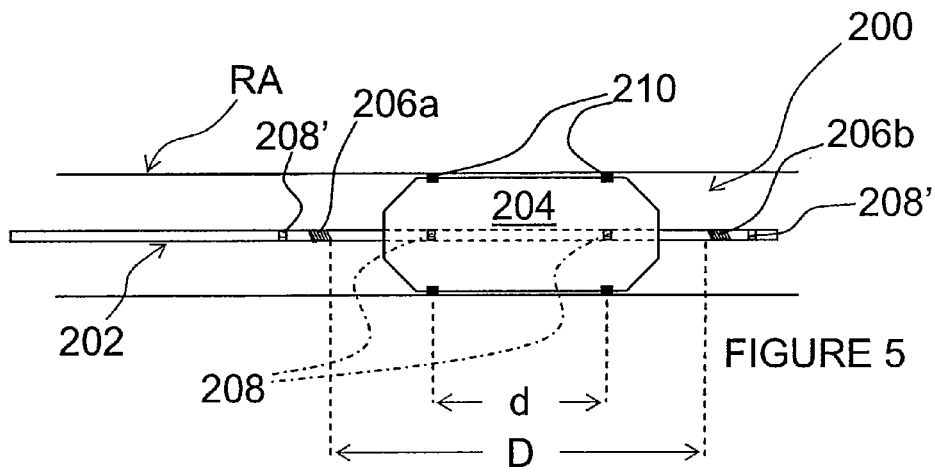
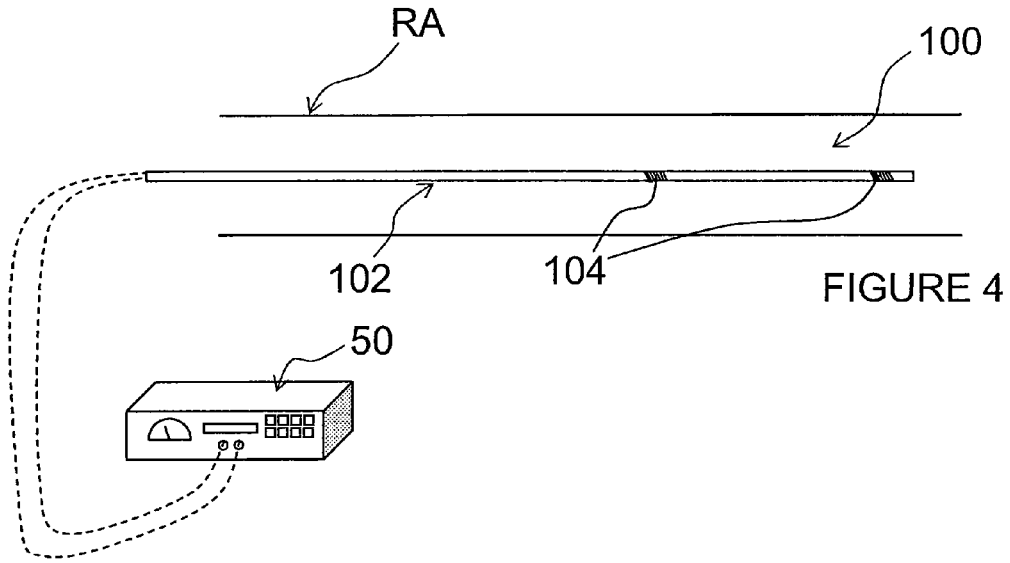

FIGURE 1





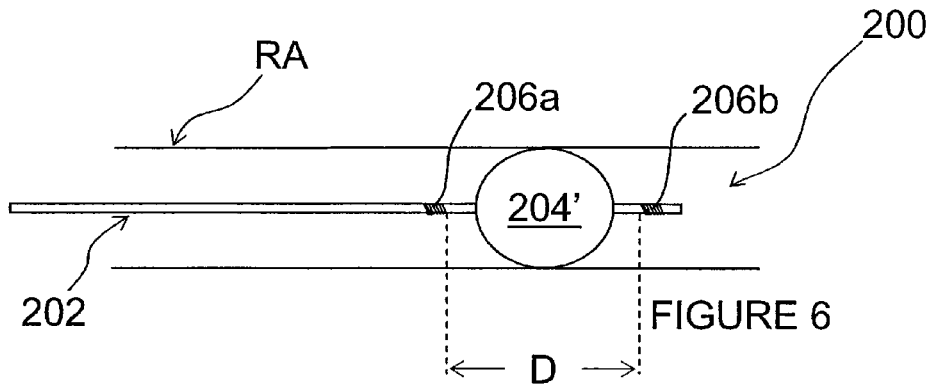

FIGURE 6

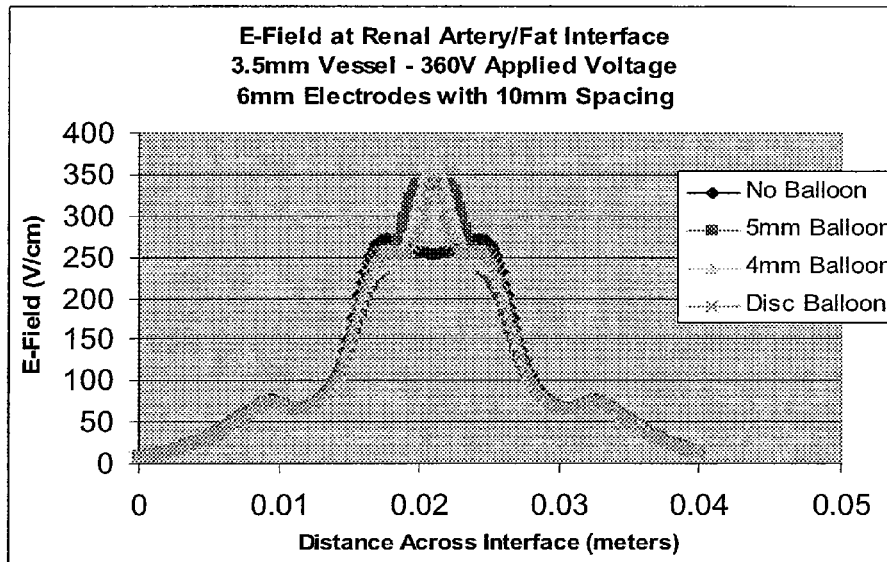

FIGURE 8

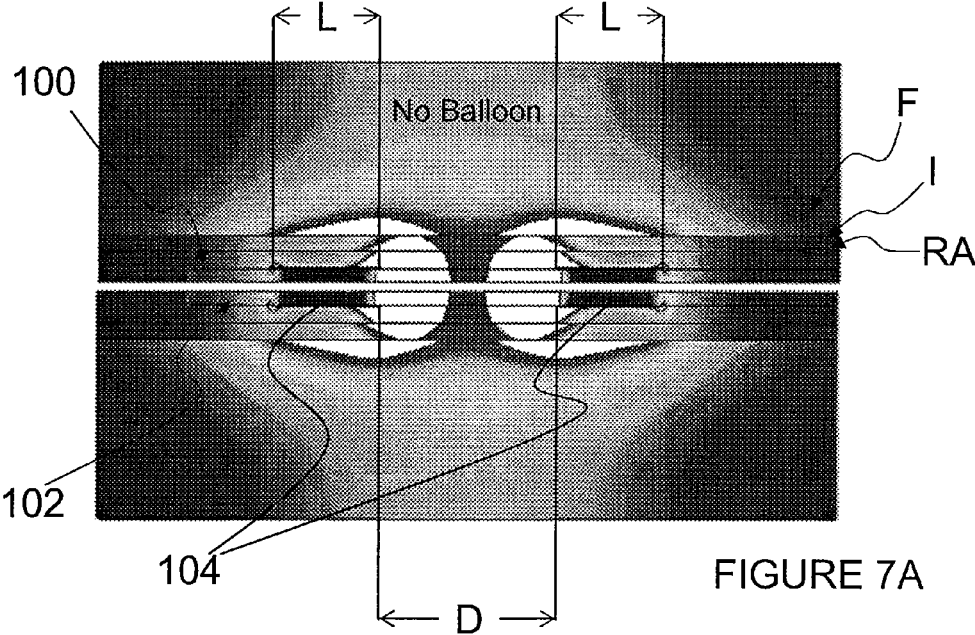

FIGURE 7A

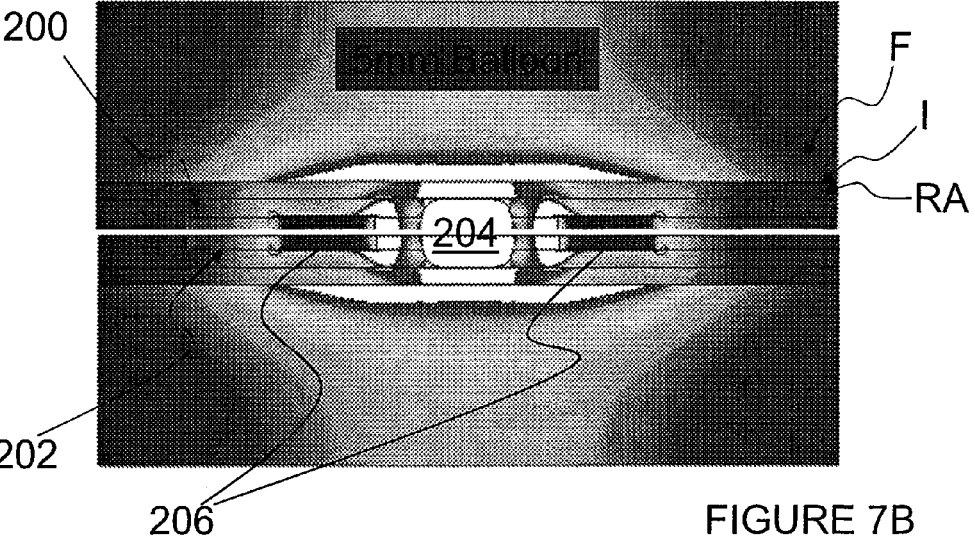

FIGURE 7B

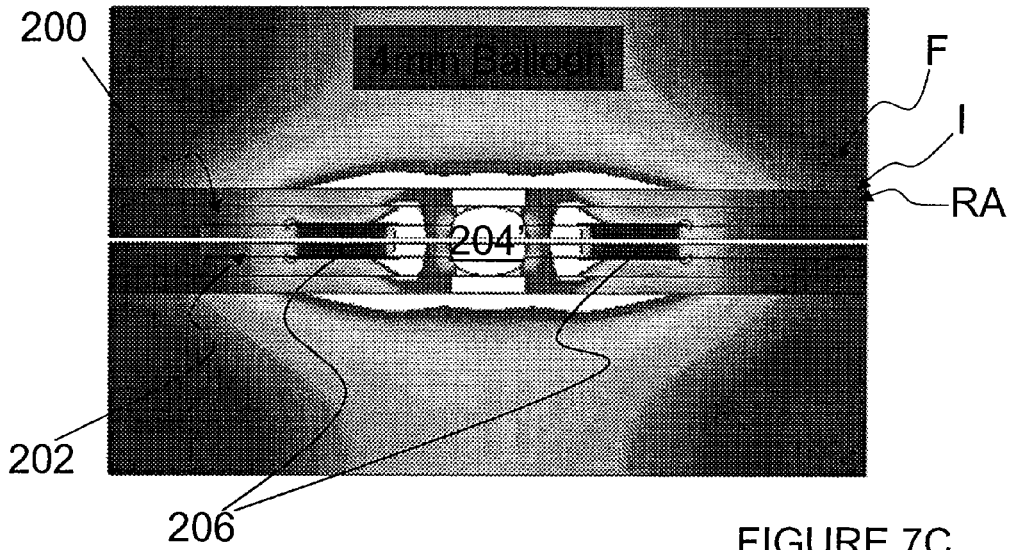

FIGURE 7C

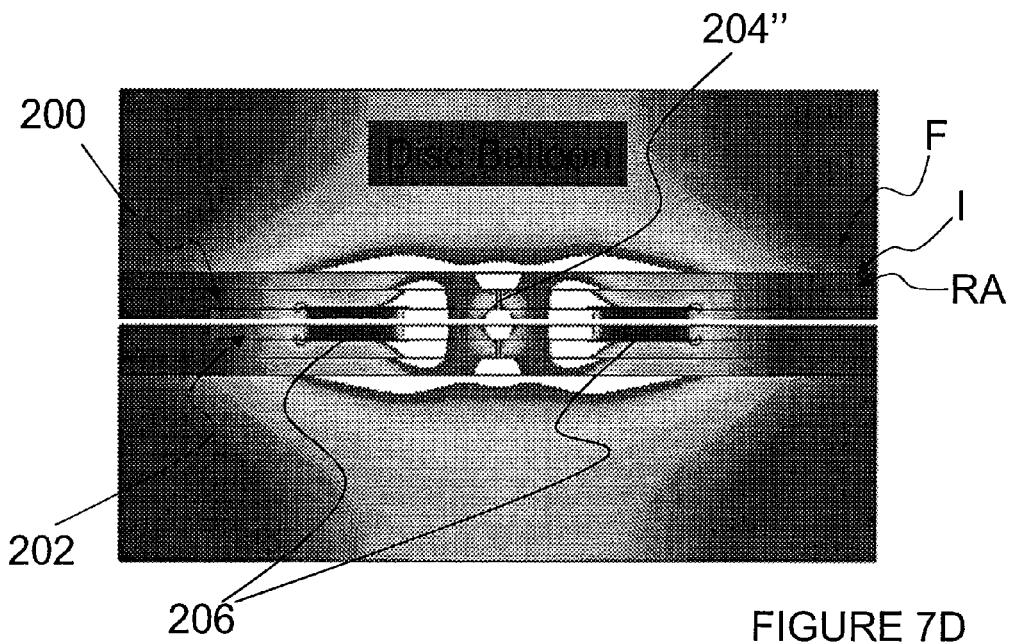

FIGURE 7D

METHODS AND APPARATUS FOR INTRAVASCULARLY-INDUCED NEUROMODULATION

CROSS-REFERENCE TO RELATED APPLICATIONS

[0001] The present application is a continuation of U.S. patent application Ser. No. 13/934,133, filed Jul. 2, 2013, which is a continuation of U.S. patent application Ser. No. 12/827,700, filed Jun. 30, 2010, now abandoned, which is a divisional of U.S. patent application Ser. No. 11/266,993, filed Nov. 4, 2005, now U.S. Pat. No. 7,756,583, which is a continuation-in-part of U.S. patent application Ser. No. 11/129,765, filed on May 13, 2005, now U.S. Pat. No. 7,653,438, which claims the benefit of U.S. Provisional Application Nos. 60/616,254, filed on Oct. 5, 2004; and 60/624,793, filed on Nov. 2, 2004. U.S. patent application Ser. No. 11/266,993, filed Nov. 4, 2005, now U.S. Pat. No. 7,756,583, is a continuation-in-part of U.S. patent application Ser. No. 10/408,665, filed on Apr. 8, 2003, now U.S. Pat. No. 7,162,303, which claims the benefit of U.S. Provisional Patent Application Nos. 60/442,970, filed on Jan. 29, 2003; 60/415,575, filed on Oct. 3, 2002; and 60/370,190, filed on Apr. 8, 2002. Further, U.S. patent application Ser. No. 11/266,993, filed Nov. 4, 2005, now U.S. Pat. No. 7,756,583, is also a continuation-in-part of co-pending U.S. patent application Ser. No. 11/189,563, filed on Jul. 25, 2005, now U.S. Pat. No. 8,145,316.

INCORPORATION BY REFERENCE

[0002] All publications and patent applications mentioned in this specification are herein incorporated by reference to the same extent as if each individual publication or patent application was specifically and individually indicated to be incorporated by reference.

TECHNICAL FIELD

[0003] The present invention relates to methods and apparatus for neuromodulation. More particularly, the present invention relates to methods and apparatus for achieving neuromodulation via an intravascularly-delivered pulsed electric field.

BACKGROUND

[0004] Congestive Heart Failure (“CHF”) is a condition that occurs when the heart becomes damaged and reduces blood flow to the organs of the body. If blood flow decreases sufficiently, kidney function becomes impaired, which results in fluid retention, abnormal hormone secretions and increased constriction of blood vessels. These results increase the workload of the heart and further decrease the capacity of the heart to pump blood through the kidneys and circulatory system.

[0005] It is believed that progressively decreasing perfusion of the kidneys is a principal non-cardiac cause perpetuating the downward spiral of CHF. Moreover, the fluid overload and associated clinical symptoms resulting from these physiologic changes result in additional hospital admissions, poor quality of life and additional costs to the health care system.

[0006] In addition to their role in the progression of CHF, the kidneys play a significant role in the progression of Chronic Renal Failure (“CRF”), End-Stage Renal Disease (“ESRD”), hypertension (pathologically high blood pres-

sure) and other cardio-renal diseases. The functions of the kidneys can be summarized under three broad categories: filtering blood and excreting waste products generated by the body’s metabolism; regulating salt, water, electrolyte and acid-base balance; and secreting hormones to maintain vital organ blood flow. Without properly functioning kidneys, a patient will suffer water retention, reduced urine flow and an accumulation of waste toxins in the blood and body. These conditions result from reduced renal function or renal failure (kidney failure) and are believed to increase the workload of the heart. In a CHF patient, renal failure will cause the heart to further deteriorate as fluids are retained and blood toxins accumulate due to the poorly functioning kidneys.

[0007] It has been established in animal models that the heart failure condition results in abnormally high sympathetic activation of the kidneys. An increase in renal sympathetic nerve activity leads to vasoconstriction of blood vessels supplying the kidneys, decreased renal blood flow, decreased removal of water and sodium from the body, and increased renin secretion. Reduction of sympathetic renal nerve activity, e.g., via denervation, may reverse these processes.

[0008] Applicants have previously described methods and apparatus for treating renal disorders by applying a pulsed electric field to neural fibers that contribute to renal function. See, for example, co-pending U.S. patent applications Ser. No. 11/129,765, filed on May 13, 2005, and Ser. No. 11/189,563, filed on Jul. 25, 2005, both of which are incorporated herein by reference in their entireties. A pulsed electric field (PEF) may initiate renal neuromodulation, e.g., denervation, for example, via irreversible electroporation or via electrofusion. The PEF may be delivered from apparatus positioned intravascularly, extravascularly, transvascularly or a combination thereof. As used herein, electrofusion comprises fusion of neighboring cells induced by exposure to an electric field. Contact between target neighboring cells for the purposes of electrofusion may be achieved in a variety of ways, including, for example, via dielectrophoresis. In tissue, the target cells may already be in contact, facilitating electrofusion.

[0009] As used herein, electroporation and electropermeabilization are methods of manipulating the cell membrane or intracellular apparatus. For example, the porosity of a cell membrane may be increased by inducing a sufficient voltage across the cell membrane through, e.g., short, high-voltage pulses. The extent of porosity in the cell membrane (e.g., size and number of pores) and the duration of effect (e.g., temporary or permanent) are a function of multiple variables, such as field strength, pulse width, duty cycle, electric field orientation, cell type or size and other parameters.

[0010] Cell membrane pores will generally close spontaneously upon termination of relatively lower strength electric fields or relatively shorter pulse widths (herein defined as “reversible electroporation”). However, each cell or cell type has a critical threshold above which pores do not close such that pore formation is no longer reversible; this result is defined as “irreversible electroporation,” “irreversible breakdown” or “irreversible damage.” At this point, the cell membrane ruptures and/or irreversible chemical imbalances caused by the high porosity occur. Such high porosity can be the result of a single large hole and/or a plurality of smaller holes.

[0011] In some patients, when a PEF sufficient to initiate irreversible electroporation is applied to renal nerves and/or other neural fibers that contribute to renal neural functions,

applicants believe that denervation induced by the PEF would result in increased urine output, decreased plasma renin levels, decreased tissue (e.g., kidney) and/or urine catecholamines (e.g., norepinephrine), increased urinary sodium excretion, and/or controlled blood pressure. Such responses would prevent or treat CHF, hypertension, renal system diseases, and other renal or cardio-renal anomalies. PEF systems could be used to modulate efferent or afferent nerve signals, as well as combinations of efferent and afferent nerve signals.

[0012] A potential challenge of using intravascular PEF systems for treating renal disorders is to selectively electroporate target cells without affecting other cells. For example, it may be desirable to irreversibly electroporate renal nerve cells that travel along or in proximity to renal vasculature, but it may not be desirable to damage the smooth muscle cells of which the vasculature is composed. As a result, an overly aggressive course of PEF therapy may persistently injure the renal vasculature, but an overly conservative course of PEF therapy may not achieve the desired renal neuromodulation.

[0013] Applicants have previously described methods and apparatus for monitoring tissue impedance or conductivity to determine the effects of pulsed electric field therapy, e.g., to determine an extent of electroporation and/or its degree of irreversibility. See, for example, Applicant's co-pending U.S. patent application Ser. No. 11/233,814, filed Sep. 23, 2005, incorporated by reference as set forth above. Pulsed electric field electroporation of tissue causes a decrease in tissue impedance and an increase in tissue conductivity. If induced electroporation is reversible, tissue impedance and conductivity should approximate baseline levels upon cessation of the pulsed electric field. However, if electroporation is irreversible, impedance and conductivity changes should persist after terminating the pulsed electric field. Thus, monitoring the impedance or conductivity of target and/or non-target tissue may be utilized to determine the onset of electroporation and to determine the type or extent of electroporation. Furthermore, monitoring data may be used in one or more manual or automatic feedback loops to control the electroporation.

[0014] Even when monitoring techniques are utilized, the applied energy or voltage from an intravascular PEF system necessary to establish an electric field of sufficient magnitude to modulate target neural fibers that contribute to renal function may be of a magnitude that causes persistent damage to non-target tissue, such as smooth muscle cells of the vessel wall. Thus, a desired treatment outcome, e.g., renal denervation, may not be achievable with some intravascular PEF systems in certain patients without concomitantly inducing persistent damage to the non-target tissue. It therefore would be desirable to provide methods and apparatus for reducing the required magnitude of applied voltage delivered from an intravascular PEF system necessary to achieve desired neuromodulation in target tissue.

SUMMARY

[0015] The present invention provides methods and apparatus for achieving neuromodulation via an intravascularly-delivered pulsed electric field ("PEF"). In some embodiments, the intravascular PEF system comprises a catheter having a pair of bipolar electrodes for delivering the PEF, with a first electrode positioned on a first side of an impedance-altering element and a second electrode positioned on an opposing side of the impedance-altering element. A length of the electrodes as well as a separation distance between the

first and second electrodes may be specified such that, with the impedance-altering element deployed in a manner that locally increases impedance within a patient's vessel, a magnitude of applied voltage delivered across the bipolar electrodes necessary to achieve desired neuromodulation is reduced relative to an intravascular PEF system having similarly spaced electrodes but no (or an undeployed) impedance-altering element. For example, the impedance-altering element can be deployed to contact the vessel wall at a treatment site within the patient's vasculature to locally increase the impedance within a vessel. In a preferred embodiment, the impedance-altering element comprises an inflatable balloon configured to locally increase impedance within a patient's vasculature. The methods and apparatus of the present invention may be used to modulate a neural fiber that contributes to renal function.

[0016] Pulsed electric field parameters may be altered and combined in any combination, as desired. Such parameters can include, but are not limited to, voltage, field strength, pulse width, pulse duration, the shape of the pulse, the number of pulses and/or the interval between pulses (e.g., duty cycle), etc. Suitable field strengths include, for example, strengths of up to about 10,000 V/cm. Suitable pulse widths include, for example, widths of up to about 1 second. Suitable shapes of the pulse waveform include, for example, AC waveforms, sinusoidal waves, cosine waves, combinations of sine and cosine waves, DC waveforms, DC-shifted AC waveforms, RF waveforms, square waves, trapezoidal waves, exponentially-decaying waves, combinations thereof, etc. Suitable numbers of pulses include, for example, at least one pulse. Suitable pulse intervals include, for example, intervals less than about 10 seconds. These parameters are provided for the sake of illustration and should in no way be considered limiting.

BRIEF DESCRIPTION OF THE DRAWINGS

[0017] Several embodiments of the present invention will be apparent upon consideration of the following detailed description, taken in conjunction with the accompanying drawings, in which like reference characters refer to like parts throughout, and in which:

[0018] FIG. 1 is a schematic view illustrating human renal anatomy.

[0019] FIG. 2 is a schematic detail view showing the location of the renal nerves relative to the renal artery.

[0020] FIGS. 3A and 3B are schematic side- and end-views, respectively, illustrating orienting of an electric field for selectively affecting renal nerves.

[0021] FIG. 4 is a schematic view illustrating an exemplary intravascular method and apparatus for renal neuromodulation.

[0022] FIG. 5 is a schematic view illustrating an intravascular method and apparatus of the present invention.

[0023] FIG. 6 is a schematic view illustrating an alternative intravascular method and apparatus of the present invention.

[0024] FIGS. 7A-7D are schematic cross-sectional views illustrating Finite Element Analysis modeling of spatial distributions of field strength for various intravascular PEF systems upon application of a constant magnitude applied voltage across bipolar electrodes of the PEF systems while the electrodes are positioned within a patient's renal artery.

[0025] FIG. 8 is a graph illustrating modeling estimates of induced field strength along the renal artery/fat interface with the PEF systems of FIGS. 7.

DETAILED DESCRIPTION

A. Overview

[0026] The present invention relates to methods and apparatus for neuromodulation, e.g., denervation. More particularly, the present invention relates to methods and apparatus for achieving neuromodulation via an intravascularly-delivered pulsed electric field. In some embodiments, the intravascular PEF system comprises a catheter having a pair of bipolar electrodes for delivering the PEF, with a first electrode positioned on a first side of an impedance-altering element and a second electrode positioned on an opposing side of the impedance-altering element. A length of the electrodes, as well as a separation distance between the first and second electrodes, may be specified such that a magnitude of applied voltage delivered across the bipolar electrodes necessary to achieve desired neuromodulation is reduced relative to an intravascular PEF system having similarly spaced electrodes but no (or an undeployed) impedance-altering element.

[0027] The methods and apparatus of the present invention may be used to modulate a neural fiber that contributes to renal function and may exploit any suitable electrical signal or field parameters, e.g., any electric field that will achieve the desired neuromodulation (e.g., electroporative effect). To better understand the structures of devices of the present invention and the methods of using such devices for renal neuromodulation and monitoring, it is instructive to examine the renal anatomy in humans.

B. Selected Embodiments of Methods for Neuromodulation

[0028] With reference now to FIG. 1, the human renal anatomy includes kidneys K that are supplied with oxygenated blood by renal arteries RA, which are connected to the heart by the abdominal aorta AA. Deoxygenated blood flows from the kidneys to the heart via renal veins RV and the inferior vena cava IVC. FIG. 2 illustrates a portion of the renal anatomy in greater detail. More specifically, the renal anatomy also includes renal nerves RN extending longitudinally along the lengthwise dimension L of renal artery RA generally within the adventitia of the artery. The renal artery RA has smooth muscle cells SMC that surround the arterial circumference and spiral around the angular axis θ of the artery. The smooth muscle cells of the renal artery accordingly have a lengthwise or longer dimension extending transverse (i.e., non-parallel) to the lengthwise dimension of the renal artery. The misalignment of the lengthwise dimensions of the renal nerves and the smooth muscle cells is defined as "cellular misalignment."

[0029] Referring to FIGS. 3, the cellular misalignment of the renal nerves and the smooth muscle cells may be exploited to selectively affect renal nerve cells with reduced effect on smooth muscle cells. More specifically, because larger cells require a lower electric field strength to exceed the cell membrane irreversibility threshold voltage or energy for irreversible electroporation, several embodiments of electrodes of the present invention are configured to align at least a portion of an electric field generated by the electrodes with or near the longer dimensions of the cells to be affected. In specific embodiments, the device has electrodes configured to create an electrical field aligned with or near the lengthwise dimension L of the renal artery RA to affect renal nerves RN. By aligning an electric field so that the field preferentially aligns

with the lengthwise aspect of the cell rather than the diametric or radial aspect of the cell, lower field strengths may be used to affect target neural cells, e.g., to necrose or fuse the target cells, to induce apoptosis, to alter gene expression, to change cytokine upregulation, etc. This is expected to reduce total energy delivered to the system and to mitigate effects on non-target cells in the electric field.

[0030] Similarly, the lengthwise or longer dimensions of tissues overlying or underlying the target nerve are orthogonal or otherwise off-axis (e.g., transverse) with respect to the longer dimensions of the nerve cells. Thus, in addition to aligning the PEF with the lengthwise or longer dimensions of the target cells, the PEF may propagate along the lateral or shorter dimensions of the non-target cells (i.e., such that the PEF propagates at least partially out of alignment with non-target smooth muscle cells SMC). Therefore, as seen in FIGS. 3, applying a PEF with propagation lines Li generally aligned with the longitudinal dimension L of the renal artery RA is expected to preferentially cause electroporation, electrofusion, denervation or other neuromodulation in cells of the target renal nerves RN without unduly affecting the non-target arterial smooth muscle cells SMC. The pulsed electric field may propagate in a single plane along the longitudinal axis of the renal artery, or may propagate in the longitudinal direction along any angular segment θ through a range of 0° - 360° .

[0031] A PEF system placed within and/or at least partially across the wall of the renal artery may propagate an electric field having a longitudinal portion that is aligned to run with the longitudinal dimension of the artery in the region of the renal nerves RN and the smooth muscle cell SMC of the vessel wall so that the wall of the artery remains at least substantially intact while the outer nerve cells are destroyed, fused or otherwise affected. Monitoring elements may be utilized to assess an extent of, e.g., electroporation, induced in renal nerves and/or in smooth muscle cells, as well as to adjust PEF parameters to achieve a desired effect.

C. Exemplary Embodiments of Systems and Additional Methods for Neuromodulation

[0032] With reference to FIG. 4, an embodiment of an intravascular PEF system and method is described. The system is configured for temporary intravascular placement. Furthermore, the system is configured to deliver a pulsed electric field to neural fibers for neuromodulation, e.g., to deliver the pulsed electric field to neural fibers that contribute to renal function in order to achieve renal neuromodulation. Intravascular pulsed electric field apparatus 100 comprises catheter 102 having a pair of bipolar electrodes 104 positioned along the shaft of the catheter. The electrodes are electrically connected to pulsed electric field generator 50 located external to the patient. The generator may be utilized with any embodiment of the present invention for delivery of a PEF with desired field parameters. It should be understood that PEF-delivery electrodes of embodiments described hereinafter may be electrically connected to the generator, even though the generator is not explicitly shown or described with each embodiment. The electrodes may, for example, be fabricated from wound coils of wire. When utilizing relatively long electrodes, wound coils allow the catheter to maintain a desired degree of flexibility.

[0033] In use, catheter 102 may, for example, be delivered to renal artery RA as shown, or may be delivered to a renal vein or to any other vessel in proximity to neural tissue

contributing to renal function, for example, through a guide catheter. Once positioned within the patient's vasculature, a pulsed electric field may be generated by the PEF generator **50**, transferred through catheter **102** to electrodes **104**, and delivered via the electrodes **104** across the wall of the vasculature. The PEF therapy modulates the activity along neural fibers, for example, along neural fibers that contribute to renal function, e.g., denervates the neural fibers. This may be achieved, for example, via irreversible electroporation, electrofusion, necrosis and/or induction of apoptosis in the nerve cells, alteration of gene expression, changes in cytokine upregulation, etc. In many applications, including that shown in FIG. 4, the electrodes are arranged so that the pulsed electric field is aligned with the longitudinal dimension of the renal artery to facilitate modulation of renal nerves with limited effect on non-target smooth muscle cells or other cells.

[0034] It is expected that PEF therapy will alleviate clinical symptoms of CHF, hypertension, renal disease and/or other cardio-renal diseases for a period of months, potentially up to six months or more. This time period might be sufficient to allow the body to heal; for example, this period might reduce the risk of CHF onset after an acute myocardial infarction, thereby alleviating a need for subsequent re-treatment. Alternatively, as symptoms reoccur, or at regularly scheduled intervals, the patient might return to the physician for a repeat therapy.

[0035] In order to denervate target neural fibers, apparatus **100** must generate an electric field of sufficient strength or magnitude across the fibers to induce such denervation. Depending upon the arrangement and positioning of electrodes **104** and catheter **102**, as well as the physiology of the patient, the applied voltage necessary to achieve a field strength of sufficient magnitude at the neural fibers might also be of sufficient magnitude to induce undesirable persistent injury in non-target tissue, such as smooth muscle cells and/or the vessel wall. It therefore would be desirable to provide apparatus and methods that reduce the necessary applied voltage for intravascular renal denervation via PEF therapy, as compared to the applied voltage required when utilizing apparatus **100**.

[0036] Referring now to FIG. 5, an embodiment of an intravascular PEF system of the present invention is described. This embodiment includes an apparatus **200** comprising a catheter **202** having impedance-altering element **204**, such as an inflatable balloon, an expandable cage (e.g., a polymer-coated expandable wire cage) or some other expandable element. Several embodiments of the impedance altering element **204** are configured to center electrodes **206** within a vessel. In a preferred embodiment, impedance-altering element **204** is configured to locally increase impedance within a patient's vasculature. In a further preferred embodiment, impedance-altering element **204** comprises an inflatable balloon, as shown in FIG. 5.

[0037] PEF-delivery electrodes **206a** and **206b** are positioned along the shaft of catheter **202** with known separation distance D ; and optional radiopaque markers **208** are positioned along the shaft of the catheter in the region of impedance-altering element **204**. The radiopaque markers **208** can be spaced apart from each other along a balloon-type impedance-altering element by known separation distance d . The electrodes **206a-b**, for example, can be arranged such that the electrode **206a** is near a proximal end of element **204** and the electrode **206b** is near a distal end of the element **204**. Electrodes **206** are electrically coupled to pulse generator **50** (see

FIG. 4), which is positioned external to the patient, for delivery of PEF therapy. Radiopaque markers additionally or alternatively may be located along the shaft of catheter **202** outside of element **204**, as illustrated by radiopaque markers **208'**. As yet another alternative or addition, electrodes **206** may be fabricated from a radiopaque material, such as platinum, and utilized as radiopaque markers.

[0038] Apparatus **200** may further comprise optional monitoring electrodes **210**, illustratively also with known separation distance d . Applicants have previously described the use of such monitoring electrodes to monitor tissue impedance or conductivity for determining the effects of pulsed electric field therapy, e.g., for determining an extent of electroporation and/or its degree of irreversibility. See, for example, Applicant's co-pending U.S. patent application Ser. No. 11/233,814, filed Sep. 23, 2005, which is incorporated herein by reference as set forth above. Pulsed electric field electroporation of tissue causes a decrease in tissue impedance and an increase in tissue conductivity. If induced electroporation is reversible, tissue impedance and conductivity should approximate baseline levels upon cessation of the pulsed electric field. However, if electroporation is irreversible, impedance and conductivity changes should persist after termination of the pulsed electric field. Thus, monitoring of the impedance or conductivity of target and/or non-target tissue via electrodes **210** may be utilized to determine the onset of electroporation and/or to determine the type or extent of electroporation. Furthermore, monitoring data may be used in one or more manual or automatic feedback loops to control the electroporation.

[0039] Regardless of whether the effects of PEF therapy are monitored, the magnitude of voltage applied across electrodes **206** in order to establish an electric field of sufficient magnitude to modulate target neural fibers that contribute to renal function also might be of a magnitude that causes persistent damage to non-target tissue, such as smooth muscle cells of the vessel wall. Thus, a desired treatment outcome, e.g., renal denervation, might not be achievable in certain patients without concomitantly inducing persistent damage to the non-target tissue.

[0040] In accordance with the principles of the present invention, impedance-altering element **204** may reduce the magnitude of voltage applied across electrodes **206** that is required to modulate the target neural fibers. In some patients, this reduction in magnitude might lower the applied voltage below a threshold level that would cause the undesirable persistent damage to the non-target tissue. Element **204** may achieve this reduction in applied voltage magnitude, for example, by locally increasing impedance within the renal vasculature. Element **204** additionally or alternatively may facilitate use of a common applied voltage across a wider range of vessel sizes.

[0041] In embodiments where the impedance-altering element **204** comprises an inflatable balloon configured to temporarily occlude blood flow during delivery of PEF therapy across electrodes **206**, the occluding balloon may serve as an electrical insulator that locally increases electrical impedance during PEF delivery. This impedance increase may direct an electric field delivered across electrodes **206**, e.g., may direct the electric field into or across the vessel wall for modulation of target neural fibers. The impedance-altering element **204** electrically insulates a portion of the vessel in a manner that may reduce the magnitude of applied voltage or other parameters of the pulsed electric field necessary to achieve a desired

field strength at the target fibers compared to apparatus **100** of FIG. **4** that does not comprise an impedance-altering element. The desired field strength, for example, may have a magnitude sufficient to denervate the target fibers via electroporation. As discussed, this reduction may moderate persistent damage to the non-target tissue. Furthermore, by substantially centering electrodes **206** within the vessel before delivery of PEF therapy, element **204** may further reduce a potential of persistent damage to the non-target tissue of the vessel wall, etc., and/or may facilitate delivery of a more concentrically uniform electric field to the target neural fibers surrounding the renal artery. In addition, or as an alternative, to the use of balloon element **204** to achieve a desired insulation or impedance increase within a patient's vasculature between electrodes **206** during delivery of PEF therapy, the impedance change may be achieved via an insulative covering, e.g., via a polymeric tube or sleeve with closed ends, positioned about a mechanical activation member. The mechanical activation member may be configured to expand the insulative covering into, e.g., circumferential sealing contact with the vessel wall. The mechanical activation member may, for example, comprise an expandable cage. Additional methods and apparatus in accordance with the present invention for achieving the desired impedance change will be apparent to those of skill in the art.

[0042] With reference now to FIG. **6**, an alternative embodiment of apparatus **200** is described. In FIG. **5**, impedance-altering element **204** illustratively comprises a semi-compliant balloon that contacts renal artery RA over a length of the artery. In FIG. **6**, element **204'** illustratively comprises a substantially non-compliant balloon that contacts the renal artery more focally, e.g., substantially tangentially. Balloon element **204'** of FIG. **6** may have a shorter length than balloon element **204** of FIG. **5**, thereby facilitating a shorter separation distance D between PEF-delivery electrodes **206**.

[0043] Finite Element Analysis ("FEA") modeling of induced electric field strengths from various embodiments of intravascular PEF systems has been conducted to guide the design of preferred intravascular PEF system embodiments that reduce the required applied voltage needed to achieve a desired field strength at target tissue. Modeled variables of the intravascular PEF system designs included use (or lack thereof) of an element configured to locally increase impedance within a patient's vasculature (e.g., a balloon element), the physical design of the impedance-altering element, electrode size (not shown) and electrode spacing (not shown). Varying vessel diameter also was modeled.

[0044] With reference to FIGS. **7** and **8**, the FEA modeling results for four exemplary intravascular PEF systems are provided. Each of the four systems was modeled with a constant applied voltage across the electrodes (e.g., 360V), a constant electrode size (e.g., 6 mm), and a constant electrode separation distance (e.g., 10 mm) within a vessel of constant diameter (e.g., 3.5 mm). These models facilitate study of the effect of the design of the impedance-altering element on induced field strength at target tissue. In FIGS. **7** and **8**, the PEF electrodes illustratively are centered with the vessel. The impedance-altering element preferably facilitates centering of the electrodes within the vessel.

[0045] As seen in FIG. **7A**, the first PEF system embodiment comprises a variation of apparatus **100** of FIG. **4** that does not comprise an impedance-altering element or that comprises an undeployed impedance-altering element, such as a deflated balloon element. As seen in FIG. **7B**, the second

embodiment comprises a variation of apparatus **200** of FIG. **5** comprising a 5 mm-long balloon element configured to alter impedance within a patient's vasculature, illustratively a semi-compliant balloon. In FIG. **7C**, the third embodiment comprises a variation of apparatus **200** of FIG. **6** wherein balloon element **204'** is 4 mm long, illustratively non-compliant, and makes only tangential contact with the wall of the renal artery RA. In FIG. **7D**, the fourth embodiment comprises another variation of apparatus **200** wherein the balloon element **204''** comprises a disc that occludes the renal artery RA over a very short length and makes substantially tangential wall contact.

[0046] The four embodiments each comprise a pair of bipolar PEF-delivery electrodes (electrodes **104** in FIG. **7A** and electrodes **206** in FIGS. **7B-7D**) with a constant separation distance D between each of the electrodes e.g., 10 mm), and a constant electrode length L (e.g., 6 mm). Similar modeling was conducted with a separation distance of 20 mm between the electrodes (not shown), and it was determined that a separation distance of less than about 20 mm is desirable in order to significantly alter the requisite magnitude of applied voltage needed with an inflated balloon to achieve a desired field strength magnitude along target neural tissue. Use of a balloon element when the electrode spacing was about 20 mm or greater showed little difference in required applied voltage between when a balloon was, and was not, used.

[0047] Electrodes **206** illustratively comprise 6 mm electrodes. Modeling also was conducted with 3 mm electrodes (not shown), and it was determined that the required applied voltage for a given field strength at target tissue generally increases as electrode length decreases. Thus, it generally is desirable to have longer electrodes, for example, electrodes preferably longer than about 1 mm, even more preferably longer than about 2 mm.

[0048] FIG. **8** provides a graph illustrating modeling estimates of induced field strength in the vicinity of target neural fibers along the renal artery RA/fat F interface I when 360V are applied across modeled bipolar electrodes of the modeled PEF system embodiments of FIGS. **7**. FIGS. **7** and **8** illustrate that, for the modeled PEF system designs, use of an impedance-altering element such as a balloon directs the electrical field across the wall of the renal artery. Furthermore, the peak field strength induced in the vicinity of the target neural fibers, i.e., at interface I, is increased. Thus, a lower applied voltage may be required to obtain a desired peak electric field strength at interface I when an impedance-altering element is utilized, as compared to when no impedance-altering element is provided or when the impedance-altering element is not deployed (e.g., when a balloon element is not inflated).

[0049] The modeled systems of FIGS. **7** and **8** illustrate that the contact length between the impedance-altering element and the vessel wall does not substantially alter the peak electric field strength at the interface, so long as some wall contact exists. Furthermore, shorter contact lengths, e.g., contact lengths achieved with balloon elements having lengths of less than about 5 mm, do not substantially alter the peak electric field strength. Additional FEA models (not shown) illustrate that, for the 10 mm spacing of the bipolar electrodes and a given applied voltage, use of an impedance-altering element substantially reduces changes in peak electric field strength associated with changes in vessel diameter, as compared to PEF systems without, or with undeployed, impedance-altering elements, suggesting that a substantially constant applied voltage may be used to achieve a desired electric field strength

over a variety of vessel sizes when an impedance-altering element is used. This is in contrast to PEF system embodiments lacking impedance-altering elements; such embodiments might require increasing applied voltages with increasing vessel diameter in order to achieve a given desired peak electric field strength. The range of vessel sizes over which an impedance-altering PEF system may apply a substantially constant voltage to achieve a substantially similar peak field strength at the interface may, for example, vary between about 3 mm and 9 mm.

[0050] Although preferred illustrative variations of the present invention are described above, it will be apparent to those skilled in the art that various changes and modifications may be made thereto without departing from the invention. For example, although the variations primarily have been described for use in combination with pulsed electric fields, it should be understood that any other electric field may be delivered as desired. It is intended in the appended claims to cover all such changes and modifications that fall within the true spirit and scope of the invention.

1. Apparatus for intravascularly-induced neuromodulation, the apparatus comprising:

- a pulsed electric field generator; and
- an intravascular catheter comprising an impedance-altering element and a pair of bipolar electrodes positioned on either side of the impedance-altering element, the electrodes being electrically coupled to the pulsed electric field generator, wherein (a) the apparatus is configured for intravascular delivery of a pulsed electric field across the bipolar electrodes, and (b) the impedance-altering element is configured to locally increase impedance within a patient's vasculature between the bipolar electrodes during intravascular delivery of the pulsed electric field.

2. The apparatus of claim 1, wherein the impedance-altering element is configured to temporarily occlude blood flow within the patient's vasculature.

3. The apparatus of claim 2, wherein the impedance-altering element comprises a balloon element.

4. The apparatus of claim 3, wherein the balloon element comprises a compliant or semi-compliant balloon.

5. The apparatus of claim 3, wherein the balloon element comprises a non-compliant balloon.

6. The apparatus of claim 1, wherein the separation distance between the bipolar electrodes is not greater than about 20 mm.

7. The apparatus of claim 1, wherein each of the bipolar electrodes comprises a length of at least about 1 mm.

8. The apparatus of claim 1 further comprising at least one monitoring electrode.

9. The apparatus of claim 8, wherein the monitoring electrode is configured to monitor electroporation induced in a target neural fiber by the pulsed electric field.

10. The apparatus of claim 8, wherein the electrode is configured to monitor electroporation in non-target tissue exposed to the pulsed electric field.

11. The apparatus of claim 1, wherein the impedance-altering element is configured to substantially center the bipolar electrodes within the patient's vasculature.

12. The apparatus of claim 1, wherein the apparatus is configured for intravascular delivery of the pulsed electric field to neural fibers that contribute to renal function in order to modulate the neural fibers.

13. The apparatus of claim 1, wherein the impedance-altering element comprises an insulative covering positioned about a mechanical activation member.

14. The apparatus of claim 1, wherein the impedance altering element is configured to locally increase impedance within the patient's vasculature along a segment of the vasculature having a length of less than about 20 mm.

15. A method for intravascularly-induced neuromodulation, the method comprising:

- positioning a pair of bipolar electrodes within a patient's vasculature, the electrodes being spaced less than about 20 mm apart;
- increasing impedance within the vasculature between the bipolar electrodes; and
- delivering a pulsed electric field across the bipolar electrodes.

16. The method of claim 15, wherein positioning a pair of bipolar electrodes within a patient's vasculature further comprises positioning the pair of bipolar electrodes within the patient's renal artery.

17. The method of claim 15, wherein positioning a pair of bipolar electrodes within a patient's vasculature further comprises positioning an intravascular catheter having the bipolar electrodes within the patient's vasculature.

18. The method of claim 17, wherein positioning an intravascular catheter having the bipolar electrodes further comprises positioning an intravascular catheter having an impedance-altering element positioned between the bipolar electrodes.

19. The method of claim 18, wherein locally increasing impedance further comprises locally increasing impedance with the impedance-altering element.

20. The method of claim 19, wherein locally increasing impedance with the impedance-altering element further comprises occluding blood flow in the vasculature with the impedance-altering element.

21-30. (canceled)

* * * * *