



US 20210016642A1

(19) **United States**

(12) **Patent Application Publication**  
**Bernardo et al.**

(10) **Pub. No.: US 2021/0016642 A1**

(43) **Pub. Date: Jan. 21, 2021**

(54) **RETRACTABLE TRUCK BED COVER  
HAVING SLAT ARRAY WITH FLEXIBLE  
JOINER MEMBERS AND SHIELDED SEAMS**

*B60J 7/08* (2006.01)

*B60J 7/19* (2006.01)

(52) **U.S. Cl.**

CPC ..... *B60J 7/041* (2013.01); *B60J 7/196*  
(2013.01); *B60J 7/085* (2013.01); *B60J*  
*10/277* (2016.02)

(71) Applicant: **ROLL-N-LOCK CORPORATION,**  
Pompano Beach, FL (US)

(72) Inventors: **Richard Gregory Bernardo,** Pompano  
Beach, FL (US); **Brandon Gregory**  
**Bernardo,** Pompano Beach, FL (US)

(57) **ABSTRACT**

(21) Appl. No.: **17/065,415**

(22) Filed: **Oct. 7, 2020**

**Related U.S. Application Data**

(63) Continuation of application No. 16/144,906, filed on  
Sep. 27, 2018, now Pat. No. 10,800,231, which is a  
continuation of application No. 15/213,180, filed on  
Jul. 18, 2016, now Pat. No. 10,137,766, which is a  
continuation of application No. 14/450,616, filed on  
Aug. 4, 2014, now Pat. No. 9,399,391.

A retractable truck bed cover having an array of parallel aluminum slats joined together by connective hinges including leading and trailing edge configuration for improving the security of the cover by covering and concealing the seam between adjacent slats while improving the connective hinge's resistance to the effects of aging and/or exposure to temperature fluctuations. The truck bed cover connective hinge slat is designed to be in an array of discrete slats, which are joined to one another by means of joiner members secured at each end to slat end caps. The distal ends of the joiner members are attached to slat end caps at the distal ends of the slats, thereby preventing the joiner members from shrinking in relationship to the slats due to aging and I or exposure to temperature fluctuations.

**Publication Classification**

(51) **Int. Cl.**

*B60J 7/04* (2006.01)

*B60J 10/277* (2006.01)

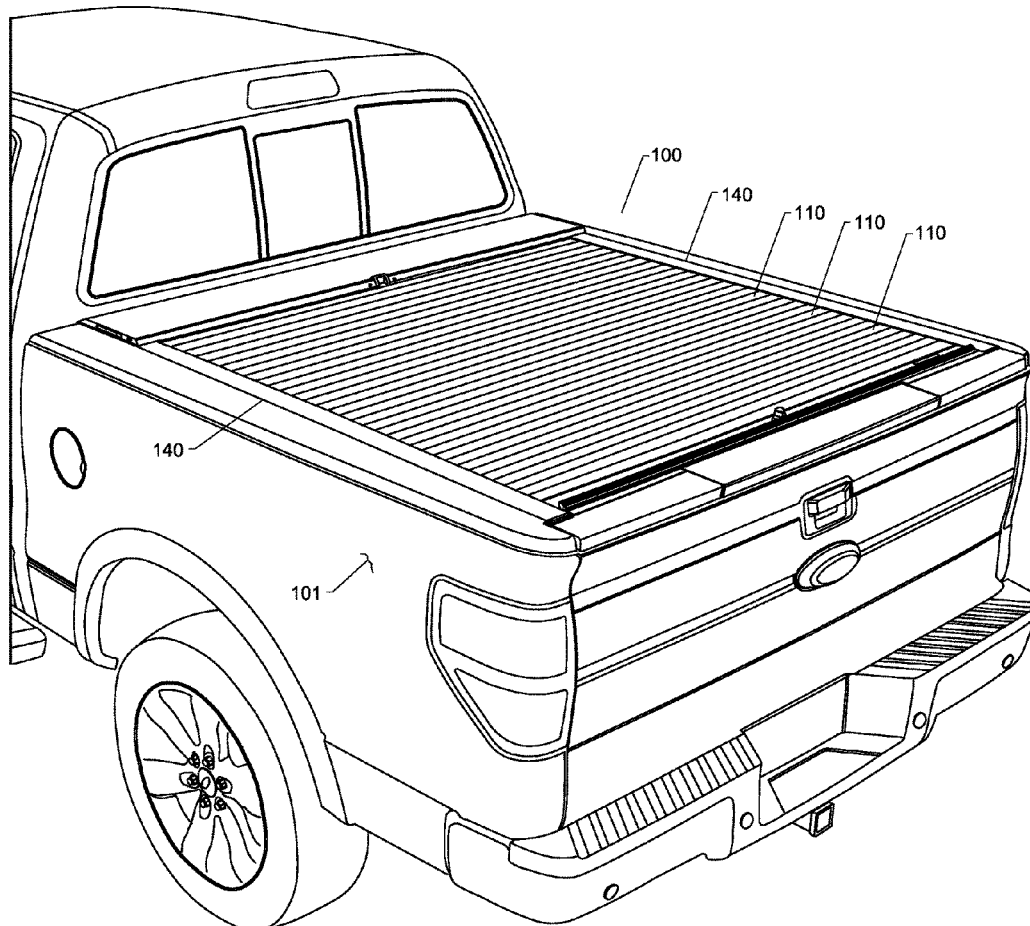

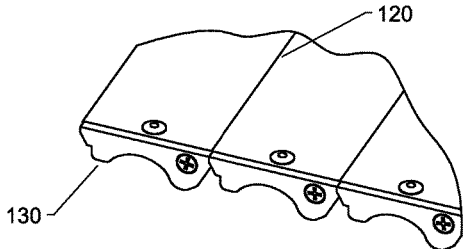
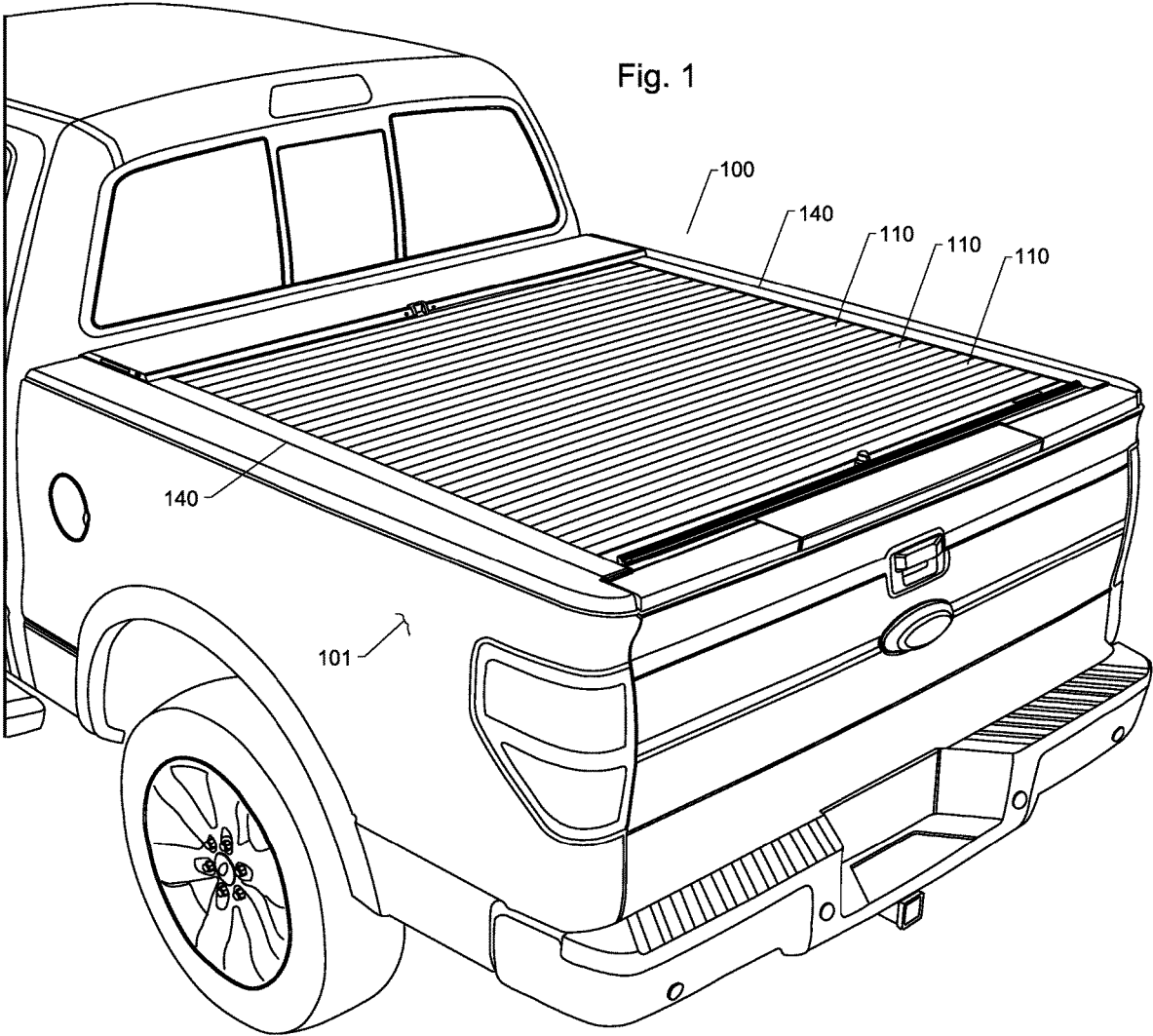

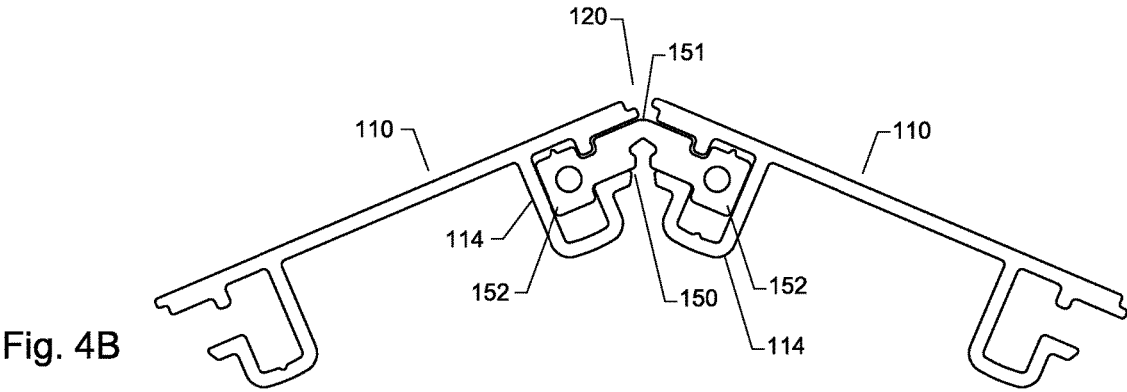
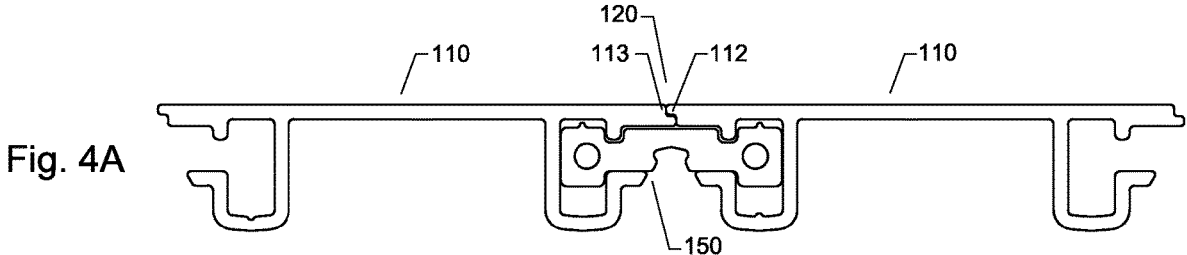
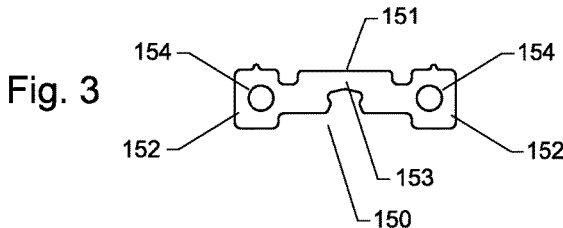
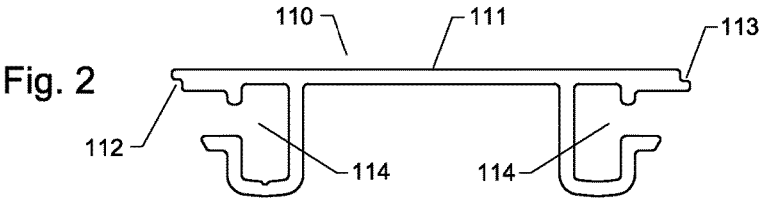

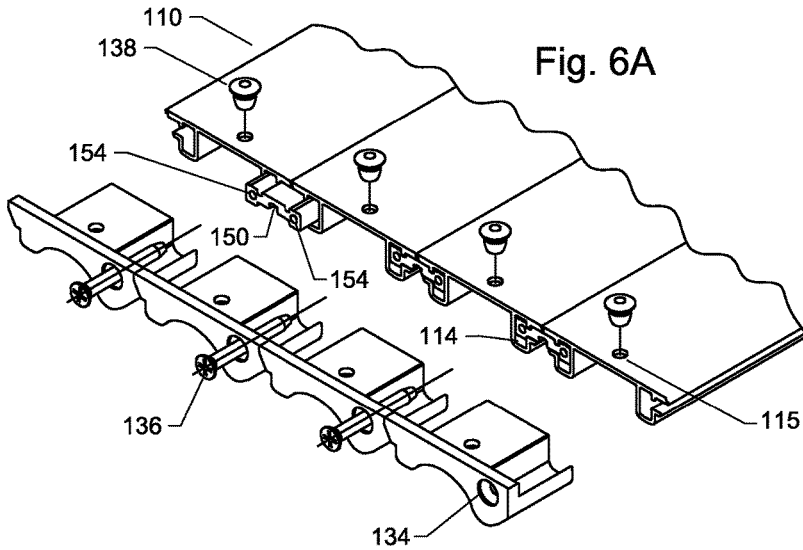

Fig. 5

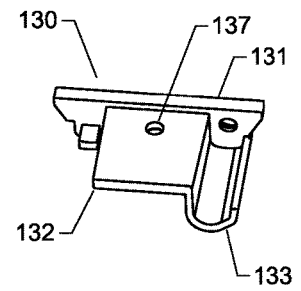

Fig. 6B

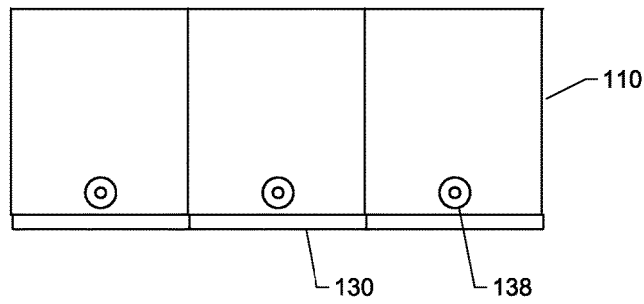

Fig. 6C

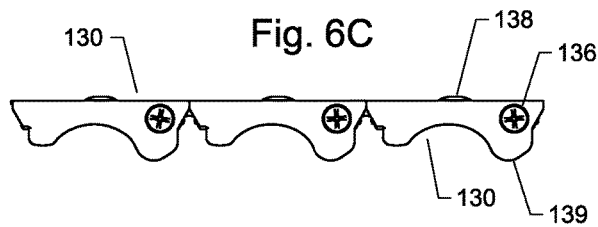
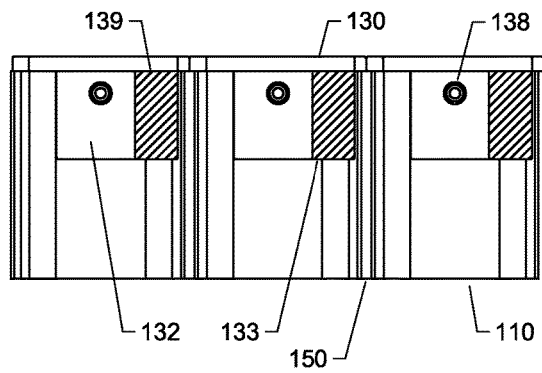

Fig. 6D



**RETRACTABLE TRUCK BED COVER  
HAVING SLAT ARRAY WITH FLEXIBLE  
JOINER MEMBERS AND SHIELDED SEAMS**

CROSS-REFERENCE TO RELATED  
APPLICATIONS

[0001] Applicant hereby incorporates by reference the disclosures of Applicant's U.S. Pat. No. 5,252,950, entitled "Rolling cover for a truck utility bed having improved reel support housing and guide track clamps," U.S. Pat. No. 5,330,246, entitled "Slat block and guide track apparatus for rolling truck bed cover," and U.S. Pat. No. 6,113,176, entitled "Slat house hinge for laminated retractable truck bed cover." Any and all applications for which a foreign or domestic priority claim is identified in the Application Data Sheet as filed with the present application are hereby incorporated by reference under 37 CFR 1.57.

BACKGROUND OF THE INVENTION

Field of the Invention

[0002] This invention relates generally to a retractable truck bed cover made up of an array of parallel aluminum slats joined together along each slat's leading and trailing edges for water integrity, security and flexibility.

Description of the Related Art

[0003] The design and use of retractable truck bed covers with open bed pickup trucks to provide security and protection for cargo items carried within the truck bed is well known. Conventional retractable truck bed covers commonly include a plurality of individual slats hingedly connected to form a slat array. The hinged connection of individual slats enables the slat array to form a continuous cover that, once mounted in a pair of side rails, can be moved from a first flat position covering the truck bed to a second stored position where the cover is retracted (rolled up) on a reel or spindle in a housing.

[0004] One type of slat array design for conventional retractable truck bed covers is defined by rigid individual slats, generally extruded or formed aluminum, which are arranged together along their edges such that their edges are overlapped and covered with a pliable, continuous surface material laminate. In this laminated slat array design, the individual slats overlap, engaging one another in an interlocking joint, while the laminate surface material functions to secure the overlapping slats together, to form an articulating cover body.

[0005] Another type of slat array design for conventional retractable truck bed covers is defined by rigid slats joined together along their edges with connective hinge bodies such that they are immediately contiguous to one another with adjacent slats fastened together without overlapping. For this connective hinge slat array design, flexible joiner members are commonly utilized as connective hinge bodies to attach adjacent individual slats by engaging and extending (or bridging) between receptor channels disposed in the opposing edges of the adjacent slats. In this regard, the joiner members are operative to both attach the slats together and enable the desired hinging movement between adjacent slats because of their flexibility. The joiner members also function as the water seal or gasket between the contiguous slats and

therefore, to function effectively, must be continuous from end to end (along the entire length) of the contiguous slats. [0006] While this connective hinge type of slat array design provides some manufacturing efficiencies, it is also subject to some well-known weaknesses and vulnerabilities. One such weakness comes from the ease in which the individual slats can be separated. Because the individual slats are arranged so that they do not overlap when joined together and are not covered by a laminate surface material, the seam between individual slats remains exposed. If a box cutter, razor knife, or other blade is simply inserted into and run along the exposed seam between contiguous slats, the joiner member can be cut, thereby detaching the contiguous slats and breaching the security of the cover. Another vulnerability relates to the tendency for the joiner member, which are typically extruded silicon, to contract over time due to aging and/or exposure to temperature fluctuations. This shrinkage often results in the joiner members no longer extending from end to end of contiguous slats, leaving the end portions of such contiguous slats that make up the slatted array with exposed spaces between the slats and compromising the water tightness of the cover body.

[0007] Accordingly, there remains a need for a modified retractable truck bed cover design which would eliminate exposed seam security vulnerability of conventional connective hinge style slats when placed in a slat array. It would be helpful if such a modified truck bed cover slat was able to protect the joiner member connecting adjacent slats in an array without requiring a restrictive overlap or interlock between adjacent slats. It would be additionally desirable for such a modified truck bed cover slat to overcome the problem of joiner member shrinkage and the associated issue of water penetration.

[0008] The Applicant's invention described herein provides for an improved retractable truck bed cover slat with connective hinge style slats arranged in a slat array that employs a means to address the shortcomings of prior art designs by protecting the attaching joiner member between contiguous slats while also preventing the joiner member from shrinking and contracting. The primary components of Applicant's modified truck bed cover slat are an aluminum base slat, a silicon joiner member, and a molded slat end cap. When in operation, the modified truck bed cover slat allows the assembly of a slat array which improves the security provided by conventional connective hinge slatted truck bed covers and addresses other limitations or shortcomings imposed by the conventional slat structures in the prior art.

SUMMARY OF THE INVENTION

[0009] A retractable truck bed cover comprising an array of parallel elongated, extruded aluminum slats joined together along their overlapped leading and trailing edges by flexible silicon hinges. The truck bed cover connective hinge slat improves the security of the cover by shielding access to the seam between adjacent slats while enabling stabilization of the silicone hinge joiner strip. Applicant's connective hinge slat is designed to be used in an array of discrete, adjacent slats which are each interconnectedly joined together sequentially through discrete joiner members, the distal ends of which are held fast to slat end caps, forming a continuous slat array suitable for use as a retractable truck bed cover.

[0010] Each slat includes a slat surface having a leading edge defined by an inverted step nib and trailing edge

defined by an upright step nib. When two slats are placed contiguously with the first slat's leading edge against the second slat's trailing edge, the shape of the inverted step nib and the upright step nib form an over and under half lap splice joint between the first slat and the second slat that provides a redundant structural barrier covering and protecting the seam area disposed between the two adjacent slats. Extending downward from the slat surface, on both the leading edge side and the trailing edge side, are mirror image receptor channels which are adapted to receive and hold the connector section of a hinge joiner member for the entire length of each slat.

[0011] Each slat joiner member is a single, flexible body which has a hinge section at its center that is designed to improve the flexibility of the joiner member and is disposed between two mirror image connector sections or bosses which are each sized and shaped to sleeve into and be captured within the receptor channels of opposing slats. Two adjacent slats can thus be joined together at their leading and trailing edges through the connector section on one side of the joiner member being placed in the receptor channel on the leading edge side of the first slat and the connector section on the other side of the same joiner member being placed in the receptor channel on the trailing edge side of the second slat (or vice versa). The joined adjacent slats retain the ability to pivotally hinge through the flexibility of the hinge section of the joiner member and the non-restrictive half lap splice lap joint to allow the truck bed cover to be retracted and extended.

[0012] At each end of each discrete slat is a slat end cap independently positioned and engaged to the end of the slat, and secured thereto through the use of a rivet fastener. Each slat end cap is additionally fastened to the end connector section of the joiner member in one receptor channel of the respective slat. Through its engagement to the end of the slat and attachment to the end of the joiner member, the slat end cap provides a means for maintaining the joiner members fixed to the ends of the slat preventing the joiner member from shrinking due to aging or temperature fluctuations and the resultant leaks in the peripheral edges of the slatted cover. The slat end caps also function collectively as the primary bearing surface upon which the cover body assembly is carried within the supporting side tracks.

[0013] It is an object of this invention to provide a truck bed cover connective hinge slat which eliminates the exposed seam security vulnerability of conventional connective hinge slats when placed in a slat array.

[0014] It is another object of this invention to provide a truck bed cover connective hinge slat which protects the joiner member connecting adjacent slats in an array without requiring a restrictive overlap or interlock between adjacent slats.

[0015] It is yet another object of this invention to prevent the contraction or shrinkage of the joiner member connecting adjacent connective hinge slats due to aging or exposure to temperature fluctuations.

[0016] It is still another object of this invention to provide a bearing surface beneath an array of connective hinge slats that reduces friction and ensures smooth operation of the slatted cover body within the side support tracks of a retractable truck bed cover assembly.

[0017] These and other objects will be apparent to one of skill in the art.

#### BRIEF DESCRIPTION OF THE DRAWINGS

[0018] FIG. 1 is a perspective view of a truck bed cover built in accordance with the present invention installed onto a conventional pickup truck utility bed.

[0019] FIG. 1A is a perspective cut away view of the slat ends.

[0020] FIG. 2 is a side elevational view of a truck bed cover slat built in accordance with the present invention.

[0021] FIG. 3 is a side elevational view of the joiner member of a modified truck bed cover slat built in accordance with the present invention.

[0022] FIG. 4A is a side cross-sectional view of two adjacent truck bed cover slats connected with a joiner member in accordance with the present invention in a flat position which would represent covering a truck bed.

[0023] FIG. 4B is a side cross-sectional view of two adjacent truck bed cover slats connected with a joiner member in accordance with the present invention in a rolled up position showing the angular motion permitted with the present hinge joiner member.

[0024] FIG. 5 is a perspective view of the slat end cap of a truck bed cover slat built in accordance with the present invention.

[0025] FIG. 6A is an exploded perspective view of a truck bed cover slat assembly with an extended joiner member and slat end cap built in accordance with the present invention.

[0026] FIG. 6B is a top plan view of a truck bed cover slat assembly with an extended joiner member and slat end cap built in accordance with the present invention.

[0027] FIG. 6C is a side elevational view of a truck bed cover slat assembly with slat end caps built in accordance with the present invention.

[0028] FIG. 6D is a bottom plan view of a truck bed cover slat assembly with slat end cap built in accordance with the present invention.

#### DETAILED DESCRIPTION OF THE PREFERRED EMBODIMENT

[0029] Referring now to the drawings and in particular FIG. 1 and FIG. 1A, a retractable truck bed cover **100** in accordance with the present invention is shown having a plurality of parallel slats **110** disposed in a contiguous arrangement and attached together. A connective hinge **120** is disposed between each slat **110**, enabling the plurality of slats **110** to form a single slat array which defines the body of the truck bed cover **100**. A slat end cap **130** is secured to the end of each discrete slat **110**. The roll-up truck bed cover **100** slat array in accordance with the present invention is mounted inside a guide track **140** connected to the side **101** of the pickup truck with the slat end caps **130** providing the primary bearing surface upon which the cover body assembly is carried within the supporting side tracks.

[0030] In the preferred embodiment, each slat **110** is a rigid, elongated aluminum extruded strip which is sized to reach from one side of the truck bed to the other laterally. Along each sidewall **101** of the truck bed are mounted a pair of guide tracks **140** that are connected to the truck bed walls **101** as described in Applicant's previous patents cited above. As will be described in more detail below, the body of each slat **110** has integrally formed therein a receptor channel on both the leading and trailing edges that extend for the length of the slat. The receptor channels receive and capture one end of a joiner member, with the other end of the

joiner member captured by the opposing receptor channel of the adjacent slat **110**, forming the connective hinge **120** which enables the slats **110** to interlock pivotally with the adjacent slats **110** in an edge-to-edge array. Each joiner member extends the entire length of a slat and is fastened to an end cap **130** at each end of slat **110**. Each slat additionally includes a slat end cap **130** secured to each slat end which maintains and secures each end of the joiner member in the receptor channel to the end of its respective slat **110** to prevent shrinkage.

[0031] Referring now to FIG. 2, each discrete slat **110** includes slat surface **111** having a leading edge **112** and trailing edge **113**. The leading edge **112** is defined by an inverted step nib which forms a first structural barrier to the seam area disposed between two adjacent slats **110** arranged contiguously, edge-to-edge. The trailing edge **113** is defined by an upright step nib which forms a second structural barrier to the seam area disposed between two adjacent slats **110** arranged contiguously, edge-to-edge. When two slats **110** are placed contiguously with the first slat's **110** leading edge **112** against the second slat's **110** trailing edge **113**, the shape of the inverted step nib and the shape of the upright step nib form a half lap splice lap joint between the first slat **110** and the second slat **110**.

[0032] Integral with the slat surface **111**, on both the leading edge **112** side and the trailing edge **113** side, are mirror image receptor channels **114** which extend downwardly below the slat surface **111**. The mirror image receptor channel **114** on the side of the leading edge **112** includes an open end which faces towards the leading edge **112** and the mirror image receptor channel **114** on the side of the trailing edge **113** and includes an open end which faces towards the leading edge **112**. The receptor channels **114** enable the slat **110** to receive and hold a connector section of the joiner member shown in FIG. 3.

[0033] Referring now to FIGS. 2 and 3, a joiner member **150** in accordance with the preferred embodiment of the present invention defines a single continuous body constructed out of a flexible material such as silicon and which has a hinge section **151** disposed between two mirror image connector sections **152**. Despite the joiner member **150** being constructed out of a flexible material, the hinge section **151** additionally includes a narrowing area **153** to enable greater flexibility to bend and allow hinging movement.

[0034] Each connector section **152** is sized and shaped to slide into and be captured within a receptor channel **114** of a slat **110** built in accordance with the present invention. In this regard, a first slat **110** and a second slat **110** can be locked together in a contiguous arrangement that still permits hinging movement between slats when the connector section **152** on one side of the joiner member **150** is held in place in the receptor channel **114** on the leading edge **112** of the first slat **110** and the connector section **152** on the opposite side of the same joiner member **150** is held in place by the trailing edge **113** of the second slat **110**. Each connector section **152** additionally includes a retention aperture **154** at its center which runs longitudinally and therefore runs throughout the length of the joiner member **150**. The retention aperture **154** is sized to receive an end retention screw that enables a slat end cap to be fastened to joiner member **150**.

[0035] In the preferred embodiment, the slats **110** are constructed of extruded aluminum and the joiner members **150** are constructed out of extruded silicon. It is additionally

contemplated that the surface of the slats **110** may include a powder-coat or anodized finish that improves the overall appearance of the cover body assembly.

[0036] Referring now to FIG. 4A, a first slat **110** and a second slat **110** (collectively, slats **110**) are shown locked together by a joiner member **150** and in a flat position, wherein the slats **110** are in the same plane, constituting the covered truck bed position. The first slat **110** is positioned with its trailing edge **113** adjacent to the leading edge **112** of the second slat **110**. Together, the trailing edge **113**, leading edge **112**, and joiner member **150** form the connective hinge of the first slat **110** and the second slat **110**. With the first slat **110** and the second slat **110** in the flat position, the half lap splice lap joint remains in a closed position. The closed half-lap splice lap joint forms an offset seam, which is operative to prevent any blade or slicing structure from passing through the seam and cutting the joiner member **150**. As such, the closed half lap splice lap joint effectively protects the joiner member **150** which connects the adjacent slats **110** and eliminates the exposed seam security vulnerability present in conventional connective hinge slats.

[0037] The joiner member **150** includes two retention apertures **154**, one at the center of each connector section **152**. The retention apertures **154** each run longitudinally through the length of the joiner member **150**. The joiner members are cut flush with the ends of the slats and are therefore equal in length to the slats. When slats **110** and joiner members **150** are assembled into a slat array, the ends of each joiner member **150**, and accordingly the retention apertures **154** within the connector sections **152** of each joiner member **150**, are accessible at the ends of the slats **110**. The purpose of the retention apertures **154** is to provide an attachment receptacle to enable each end of joiner members **150** to be secured to the end of the slats and to a molded end fitting, defined as the slat end cap, which is positioned and independently secured to each end of each slat **110** to prevent the joiner member **150** from shrinking and drawing away from the ends of the slats **110**.

[0038] Referring now to FIG. 4B, a first slat **110** and a second slat **110** (collectively, slats **110**) are shown locked together by a joiner member **150**, but pivotally hinged into an acute angle relative to each other. The movement to an acute angle deforms the hinge section **151** of the joiner member **150** as the opposing connector sections **152** are pivotally folded inward relative to and toward one another.

[0039] Due to the narrowing of the hinge section **151** and the use of the half-lap splice lap joint, the extent of the acute angle in which the slats **110** can be moved is limited only by the eventual contact of the opposing receptor channel **114** of the first slat **110** with the receptor channel **114** of the second slat **110**. Indeed, the use of a half-lap splice lap joint is specifically contemplated to provide an obstruction for the seam between slats **110** that does not restrict the desired hinged movement. As such, it is understood that the capability to hinge contiguous, adjacent slats **110** into such an acute angle relative to one another enables a truck bed cover in accordance with the present invention (i.e., defined by slats **110** locked together by joiner members **150** into a slat array) to be rolled up in a smaller stored position in a manner similar to my previous patents cited above.

[0040] Referring now to FIGS. 5, 6A, 6B, 6C, and 6D, each slat end cap **130** is defined by a molded body having an end flange portion **131** and a tongue flange portion **132** with integral J section **133**. The end flange portion **131** of the slat

end cap 130 fits at a ninety (90) degree relationship to the slat's 110 longitudinal dimension and includes a countersunk hole 134 through its planar surface which aligns with the retention aperture 154 in the connector section 152 of the joiner member 150 when the tongue flange portion 132 is press-fit into the space between the receptor channels 114 of the slat 110. An end retention screw 136 passes through the countersunk hole 134 and into the retention aperture 154 to secure the joiner member 150 to the slat end cap 130. The tongue flange portion 132 of the molded slat end cap 130 also includes a cap rivet hole 137 in its planar surface, and when the tongue flange 132 is press-fit into the space between the receptor channels 114, the cap rivet hole 137 aligns with a corresponding slat rivet hole 115 in the end of the slat 110. The slat end cap 130 is permanently affixed to the end of the slat 110 by way of a rivet 138 which is passed through both the slat rivet hole 115 and the cap rivet hole 137 when the slat end cap 130 is in place on the end of the slat 110. As the slat end cap 130 is press-fitted into place, it also causes the J section 133 of the tongue flange 132 to align with and sleeve over the end portion of one receptor channel 114 of the slat 110. The bottom surface 139 of the J section 133 is then beneath the receptor channel 114, and being constructed of a specially formulated nylon, enables the J sections 133, one at the end of every slat 110 in the cover body 100 to collectively provide a bearing surface for the underside of the cover body 100 at the points at which the cover body slats 110 engage the supporting side tracks of the retractable truck bed cover assembly 100.

[0041] The retractable truck bed cover described herein can be securely locked in place covering the entire truck bed or rolled up in a housing as described in applicants' patent cited above.

[0042] The instant invention has been shown and described herein in what is considered to be the most practical and preferred embodiment. It is recognized, however, that departures may be made therefrom within the scope of the invention and that obvious modifications will occur to a person skilled in the art.

What is claimed is:

1. A retractable truck bed cover configured for use with a truck bed of a vehicle, the retractable truck bed cover comprising:

- a pair of guide rails configured to secure to side walls of the truck bed of the vehicle;
- a plurality of slats configured to extend between and be positioned at least partially within the pair of guide rails; and
- a plurality of flexible joiner members, each of the plurality of flexible joiner members configured to connect adjacent ones of the plurality of slats, each of the plurality of flexible joiner members comprising a length and a cross-section extending along the length, the cross-section comprising a first connector section, a second connector section, and a hinge section positioned between and connecting the first and second connector sections, the hinge section comprising a first surface and a second surface opposite the first surface, and a notch positioned along the second surface, wherein the first surface is planar and wherein the notch extends from the second surface to an interior portion of the hinge section between the first and second surfaces, the notch defining a narrowing portion of the hinge section;

wherein the plurality of slats comprises at least a first slat and a second slat, each of the first and second slats comprising a length and a cross-section extending along the length, the cross-section comprising:

- a slat surface having a leading edge and a trailing edge opposite the leading edge;
- a first receptor channel extending downwardly from the slat surface and positioned proximate the leading edge, the first receptor channel comprising a first side, a second side opposite the first side, and an opening on the first side, the first side being closer to the leading edge than the second side; and
- a second receptor channel extending downwardly from the slat surface and positioned proximate the trailing edge, the second receptor channel comprising a first side, a second side opposite the first side, and an opening on the second side, the second side being closer to the trailing edge than the first side, wherein the first side of the second receptor channel faces toward the second side of the first receptor channel;

wherein, when the first and second slats are connected to one another by one of the flexible joiner members:

- the first connector section is positioned within the second receptor channel of the first slat and the second connector section is positioned within the first receptor channel of the second slat; and
- a first portion of the hinge section extends through the opening on the second side of the second receptor channel of the first slat and a second portion of the hinge section extends through the opening on the first side of the first receptor channel of the second slat; and

wherein, when the first and second slats are in a flat position, the second receptor channel of the first slat is spaced from the first receptor channel of the second slat by a gap, wherein the gap and the narrowing portion of the hinge section allow the first and second slats to move between the flat position and an angled position.

2. The retractable truck bed cover of claim 1, wherein the first receptor channel extends downwardly from the slat surface to an end portion of the first receptor channel and the second receptor channel extends downwardly from the slat surface to an end portion of the second receptor channel, the opening on the first side of the first receptor channel positioned closer to the slat surface than to the end portion of the first receptor channel and the opening on the second side of the second receptor channel positioned closer to the slat surface than to the end portion of the second receptor channel.

3. The retractable truck bed cover of claim 1, wherein the length of each of the plurality of flexible joiner members extends along the length of the plurality of slats and between the pair of guide rails.

4. The retractable truck bed cover of claim 1, wherein, when the first and second slats are connected to one another by one of the flexible joiner members and the first and second slats are in the flat position, the hinged section is positioned below the slat surface.

5. The retractable truck bed cover of claim 1, wherein the notch is spaced from the first connector section by a first distance and spaced from the second connector section by a second distance, wherein the first and second distances are the same.



6. The retractable truck bed cover of claim 1, wherein the first and second receptor channels are configured to inhibit the first and second connector sections from exiting the first and second receptor channels along a direction non-parallel with respect to the length of the first and second slats.

7. The retractable truck bed cover of claim 1, wherein, when the first and second slats are in the flat position, the second side of the first receptor channel is parallel to the first side of the second receptor channel.

8. A retractable truck bed cover configured for use with a truck bed of a vehicle, the retractable truck bed cover comprising:

a plurality of slats comprising at least a first slat and a second slat, each of the first and second slats comprising a length and a cross-section extending along the length, the cross-section comprising:

a slat surface having a leading edge and a trailing edge opposite the leading edge;

a first receptor channel extending downwardly from the slat surface and positioned proximate the leading edge, the first receptor channel comprising a first side, a second side opposite the first side, and an opening on the first side, the first side being closer to the leading edge than the second side; and

a second receptor channel extending downwardly from the slat surface and positioned proximate the trailing edge, the second receptor channel comprising a first side, a second side opposite the first side, and an opening on the second side, the second side being closer to the trailing edge than the first side, wherein the first side of the second receptor channel faces toward the second side of the first receptor channel; and

a plurality of flexible joiner members, each of the plurality of flexible joiner members configured to connect adjacent ones of the plurality of slats, each of the plurality of flexible joiner members comprising a length and a cross-section extending along the length, the cross-section comprising a first connector section, a second connector section, and a hinge section positioned between and connecting the first and second connector sections, the hinge section comprising a first surface and a second surface opposite the first surface, and a notch positioned along the second surface, wherein the first surface is planar and wherein the notch extends from the second surface to an interior portion of the hinge section between the first and second surfaces, the notch defining a narrowing portion of the hinge section;

wherein, when the first and second slats are connected to one another by one of the flexible joiner members:

the first connector section is positioned within the second receptor channel of the first slat and the second connector section is positioned within the first receptor channel of the second slat; and

a first portion of the hinge section extends through the opening on the second side of the second receptor channel of the first slat and a second portion of the hinge section extends through the opening on the first side of the first receptor channel of the second slat; and

wherein, when the first and second slats are in a flat position, the second receptor channel of the first slat is spaced from the first receptor channel of the second slat by a gap, wherein the gap and the narrowing portion of

the hinge section allow the first and second slats to move between the flat position and an angled position.

9. The retractable truck bed cover of claim 8, wherein the first receptor channel extends downwardly from the slat surface to an end portion of the first receptor channel and the second receptor channel extends downwardly from the slat surface to an end portion of the second receptor channel, the opening on the first side of the first receptor channel positioned closer to the slat surface than to the end portion of the first receptor channel and the opening on the second side of the second receptor channel positioned closer to the slat surface than to the end portion of the second receptor channel.

10. The retractable truck bed cover of claim 8, wherein the length of each of the plurality of flexible joiner members extends along the length of the plurality of slats.

11. The retractable truck bed cover of claim 8, wherein, when the first and second slats are connected to one another by one of the flexible joiner members and the first and second slats are in the flat position, the hinged section is positioned below the slat surface.

12. The retractable truck bed cover of claim 8, wherein the notch is spaced from the first connector section by a first distance and spaced from the second connector section by a second distance, wherein the first and second distances are the same.

13. The retractable truck bed cover of claim 8, wherein the first and second receptor channels are configured to inhibit the first and second connector sections from exiting the first and second receptor channels along a direction non-parallel with respect to the length of the first and second slats.

14. The retractable truck bed cover of claim 8, wherein, when the first and second slats are in the flat position, the second side of the first receptor channel is parallel to the first side of the second receptor channel.

15. A retractable truck bed cover configured for use with a truck bed of a vehicle, the retractable truck bed cover comprising:

a plurality of slats comprising at least a first slat and a second slat, each of the first and second slats comprising a length and a cross-section extending along the length, the cross-section comprising:

a slat surface having a leading edge and a trailing edge opposite the leading edge;

a first receptor channel extending downwardly from the slat surface and positioned proximate the leading edge, the first receptor channel comprising a first side, a second side opposite the first side, and an opening on the first side, the first side being closer to the leading edge than the second side; and

a second receptor channel extending downwardly from the slat surface and positioned proximate the trailing edge, the second receptor channel comprising a first side, a second side opposite the first side, and an opening on the second side, the second side being closer to the trailing edge than the first side, wherein the first side of the second receptor channel faces toward the second side of the first receptor channel; and

a plurality of flexible joiner members, each of the plurality of flexible joiner members configured to connect adjacent ones of the plurality of slats, each of the plurality of flexible joiner members comprising a length and a cross-section extending along the length, the cross-

section comprising a first connector section, a second connector section, and a hinge section positioned between and connecting the first and second connector sections, the hinge section comprising a first surface and a second surface opposite the first surface, and a notch positioned along the second surface, wherein the first surface is planar and wherein the notch defines a narrowing portion of the hinge section;

wherein, when the first and second slats are connected to one another by one of the flexible joiner members and movable with respect to one another; and

wherein, when the first and second slats are in a flat position, the second receptor channel of the first slat is spaced from the first receptor channel of the second slat by a gap, wherein the gap and the narrowing portion of the hinge section allow the first and second slats to move between the flat position and an angled position.

**16.** The retractable truck bed cover of claim **15**, wherein the first receptor channel extends downwardly from the slat surface to an end portion of the first receptor channel and the second receptor channel extends downwardly from the slat surface to an end portion of the second receptor channel, the opening on the first side of the first receptor channel positioned closer to the slat surface than to the end portion of the first receptor channel and the opening on the second side of

the second receptor channel positioned closer to the slat surface than to the end portion of the second receptor channel.

**17.** The retractable truck bed cover of claim **15**, wherein, when the first and second slats are connected to one another by one of the flexible joiner members and the first and second slats are in the flat position, the hinged section is positioned below the slat surface.

**18.** The retractable truck bed cover of claim **15**, wherein the notch is spaced from the first connector section by a first distance and spaced from the second connector section by a second distance, wherein the first and second distances are the same.

**19.** The retractable truck bed cover of claim **15**, wherein the first and second receptor channels are configured to inhibit the first and second connector sections from exiting the first and second receptor channels along a direction non-parallel with respect to the length of the first and second slats.

**20.** The retractable truck bed cover of claim **15**, wherein, when the first and second slats are in the flat position, the second side of the first receptor channel is parallel to the first side of the second receptor channel.

\* \* \* \* \*