



(19) **United States**

(12) **Patent Application Publication**
Dawson

(10) **Pub. No.: US 2019/0017632 A1**

(43) **Pub. Date: Jan. 17, 2019**

(54) **MARKED CONDUIT OR TUBE**

(52) **U.S. Cl.**

(71) Applicant: **Ramon C. Dawson**, Long Beach, CA
(US)

CPC *F16L 9/00* (2013.01); *B29L 2023/22*
(2013.01); *F16L 9/006* (2013.01); *B29C 53/08*
(2013.01)

(72) Inventor: **Ramon C. Dawson**, Long Beach, CA
(US)

(57) **ABSTRACT**

(21) Appl. No.: **15/648,356**

According to various embodiments, there is provided a marked conduit or tube including: a hollow body having an outer surface, a length dimension, and a plurality of markings along the length dimension, the plurality of markings including a first line marking, where the first line marking is positioned at a 0-degree point of a cross-sectional view of the hollow body, a second line marking where the second line marking is positioned at a 90-degree point relative to the 0-degree point of the cross-sectional view of the hollow body, a third line marking, where the third line marking is positioned at a 180-degree point relative to the 0-degree point of the cross-sectional view of the hollow body, and a fourth line marking, where the fourth line marking is positioned at a 270-degree point relative to the 0-degree point of the cross-sectional view of the hollow body.

(22) Filed: **Jul. 12, 2017**

Publication Classification

(51) **Int. Cl.**
F16L 9/00 (2006.01)
B29C 53/08 (2006.01)

100

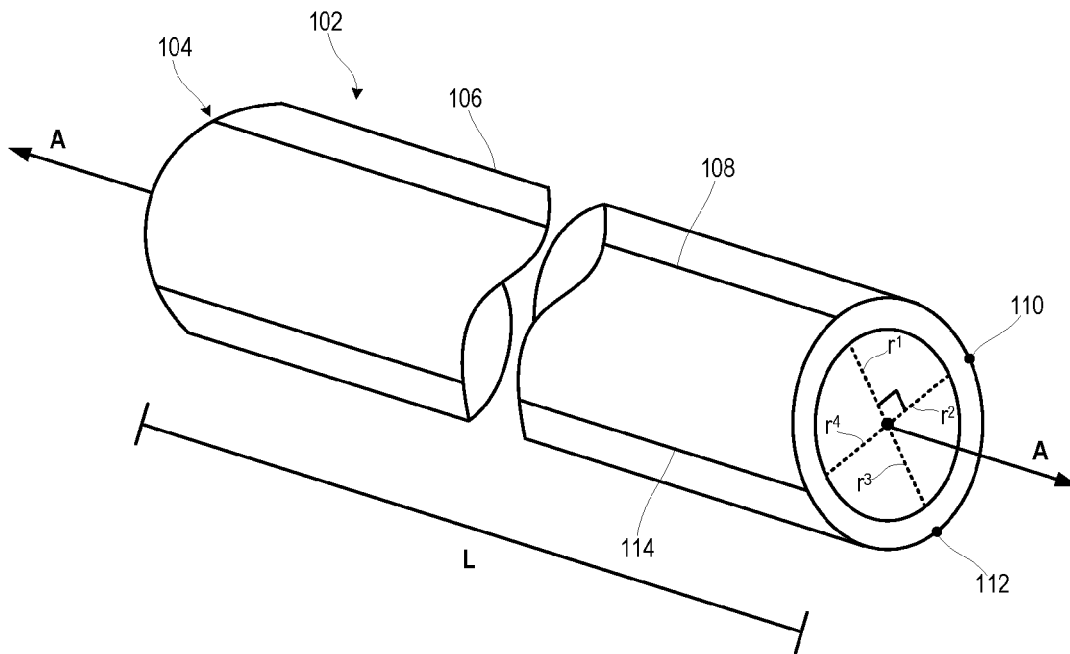

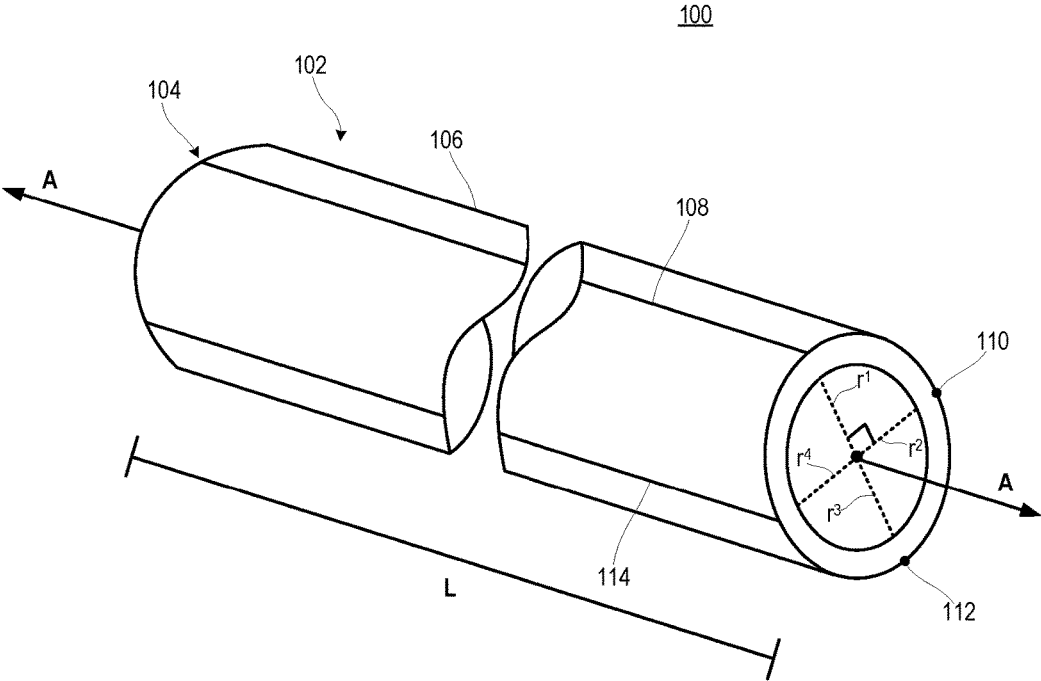

Figure 1

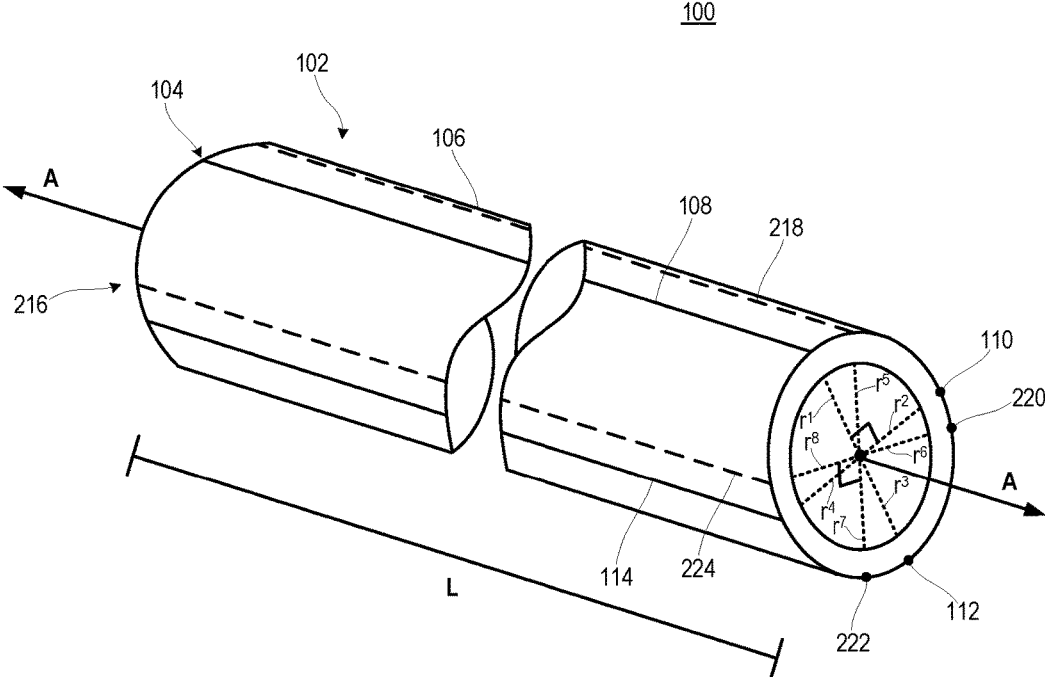

Figure 2

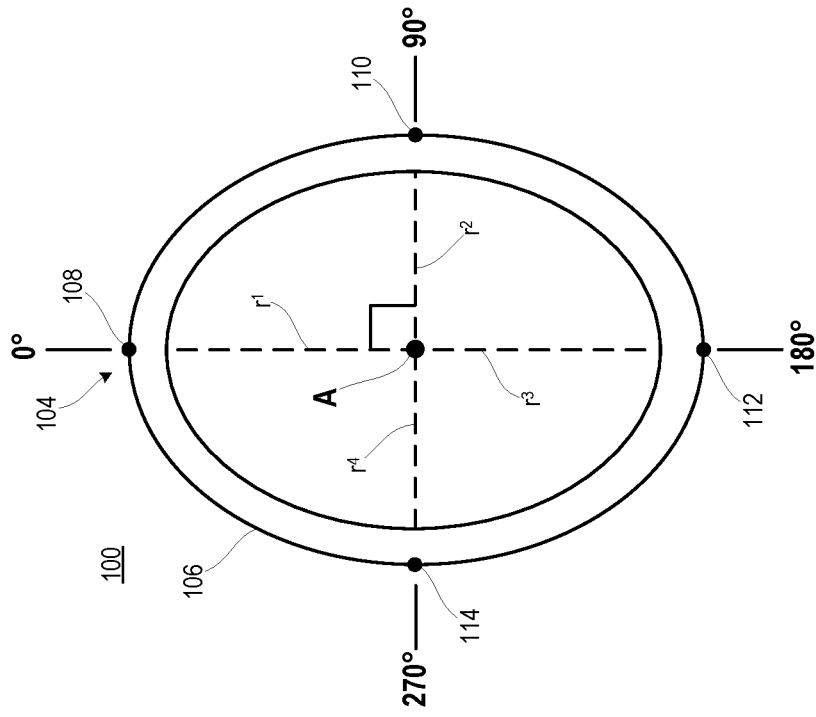

Figure 3B

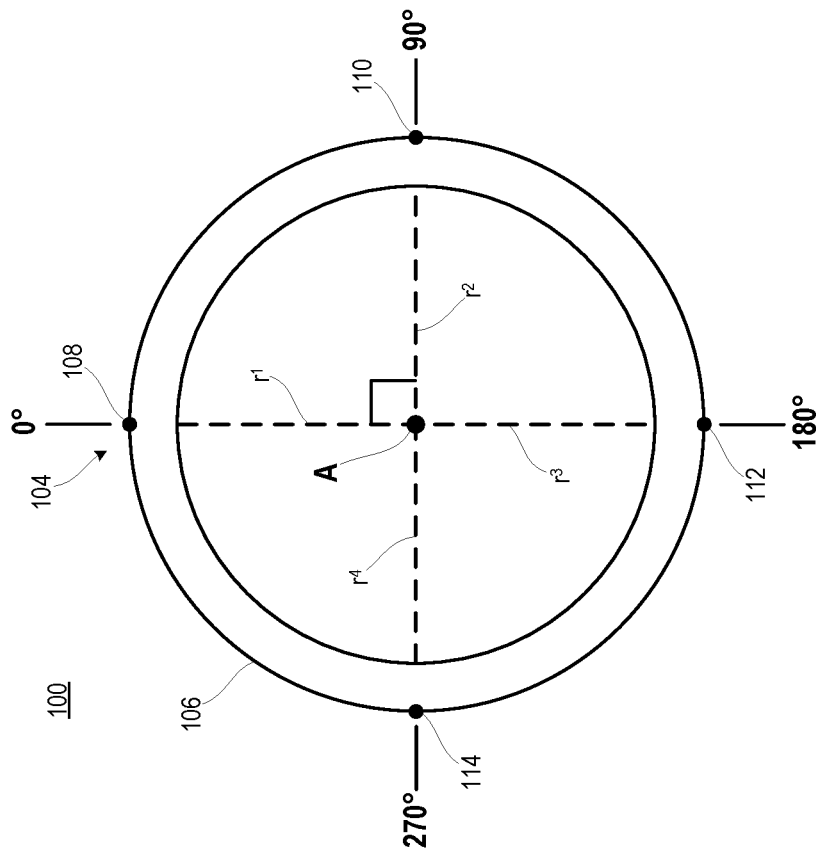
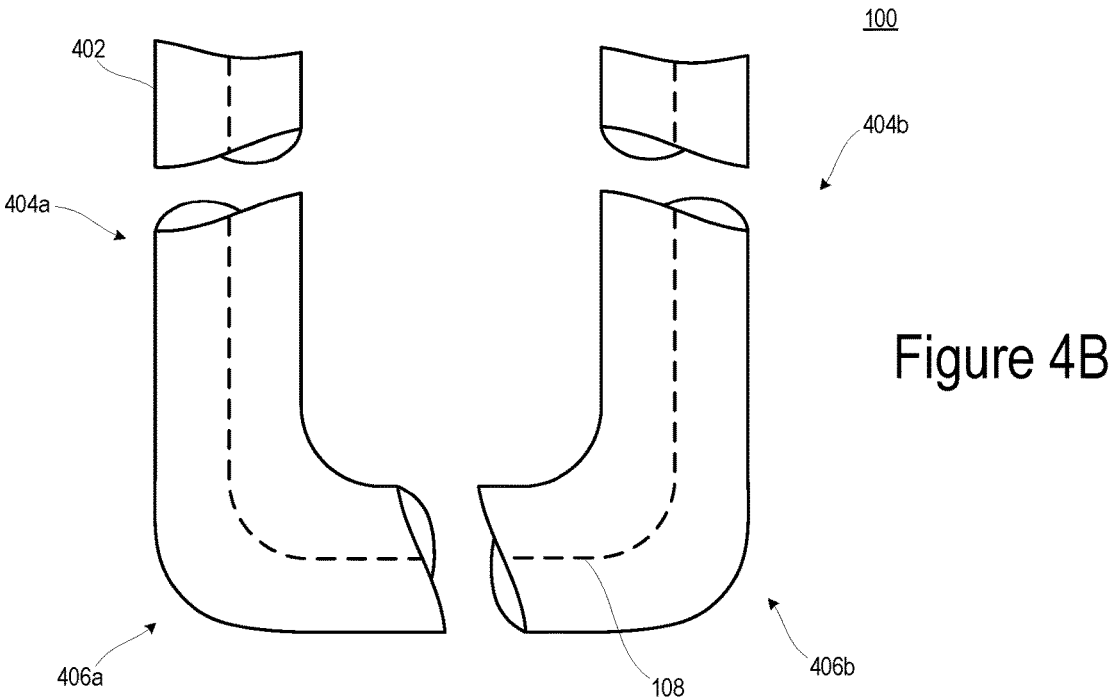
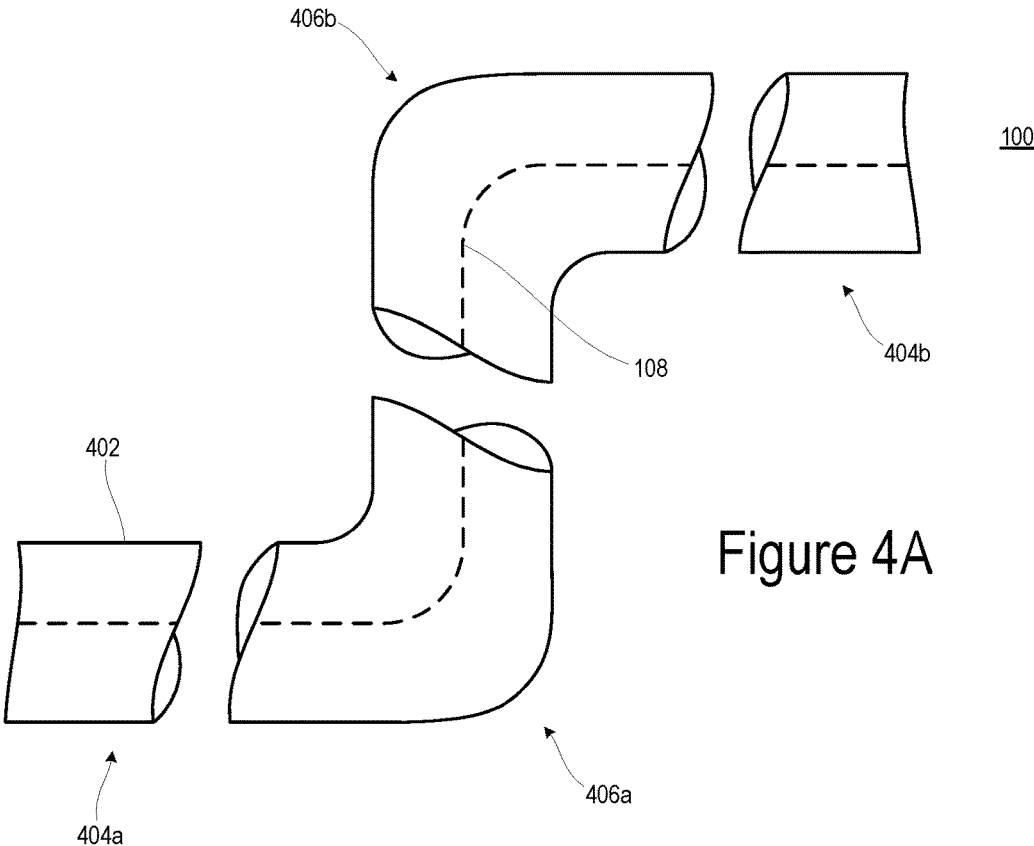

Figure 3A



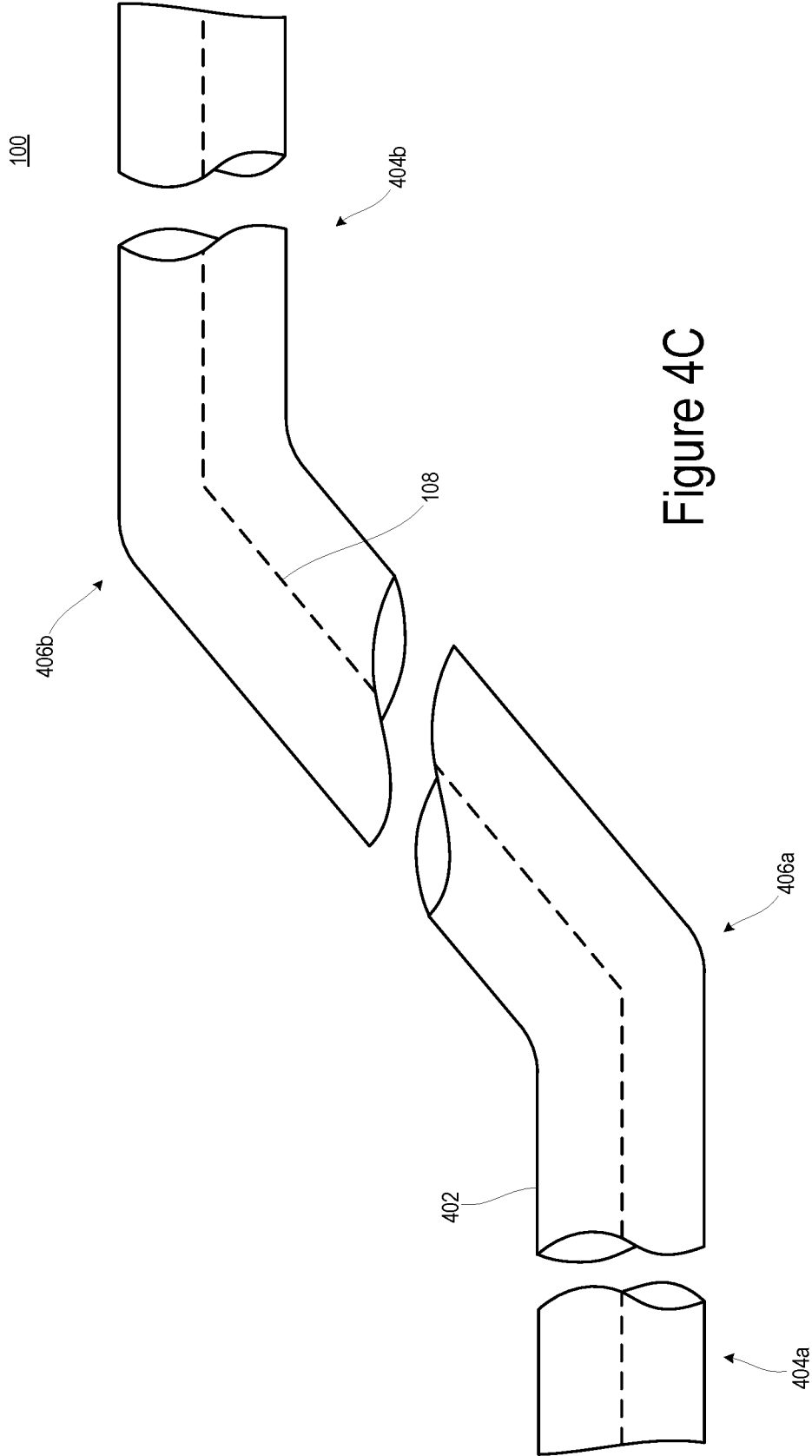

Figure 4C

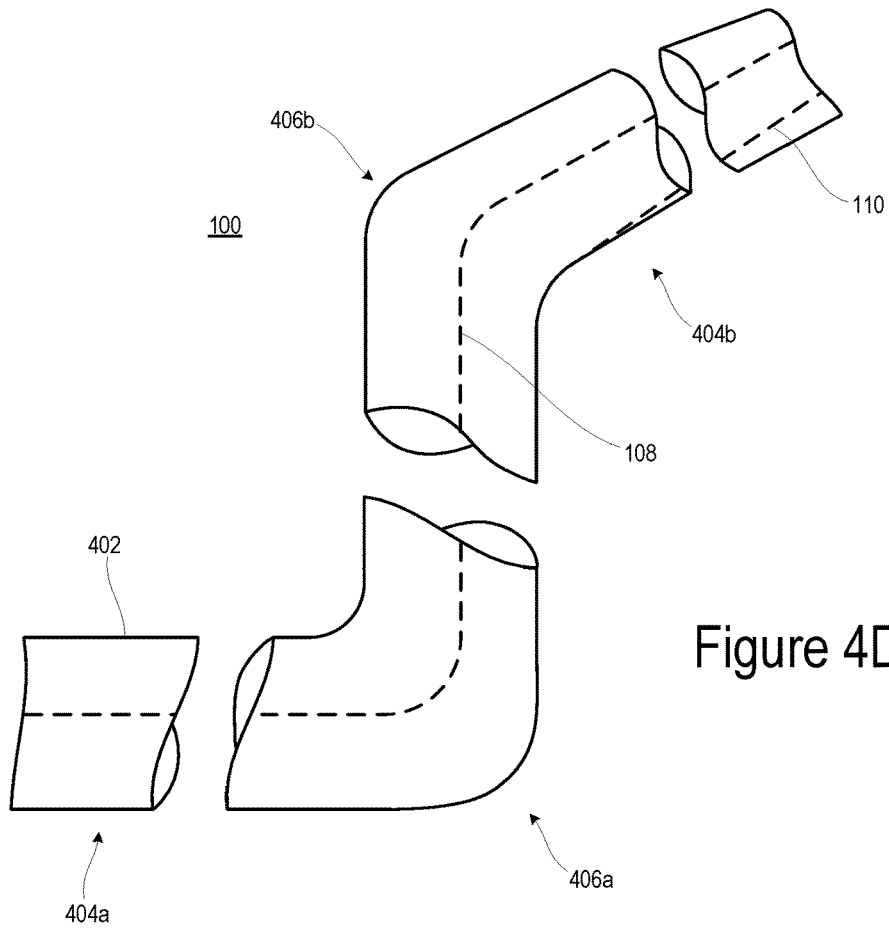

Figure 4D

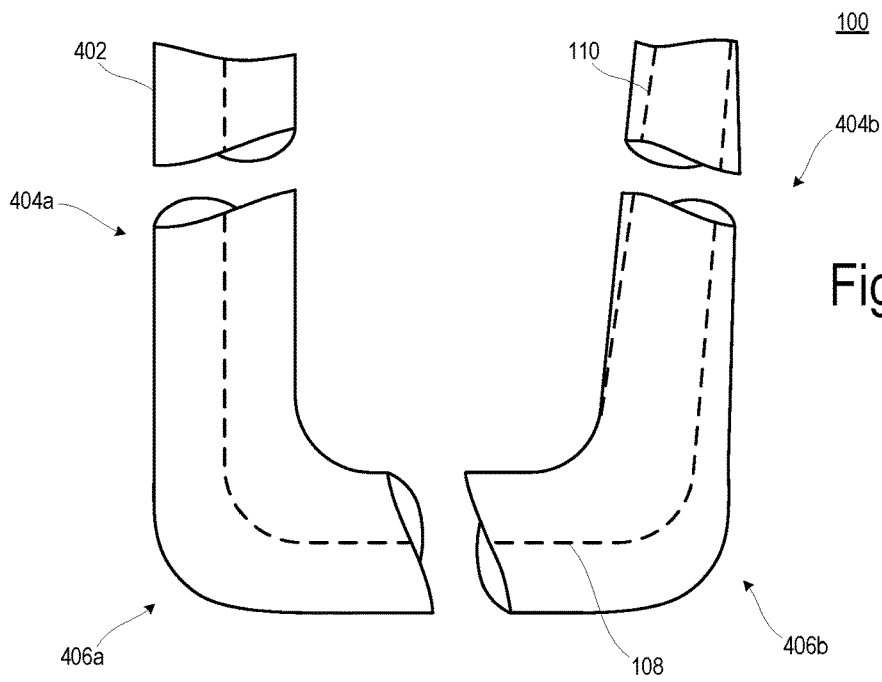

Figure 4E

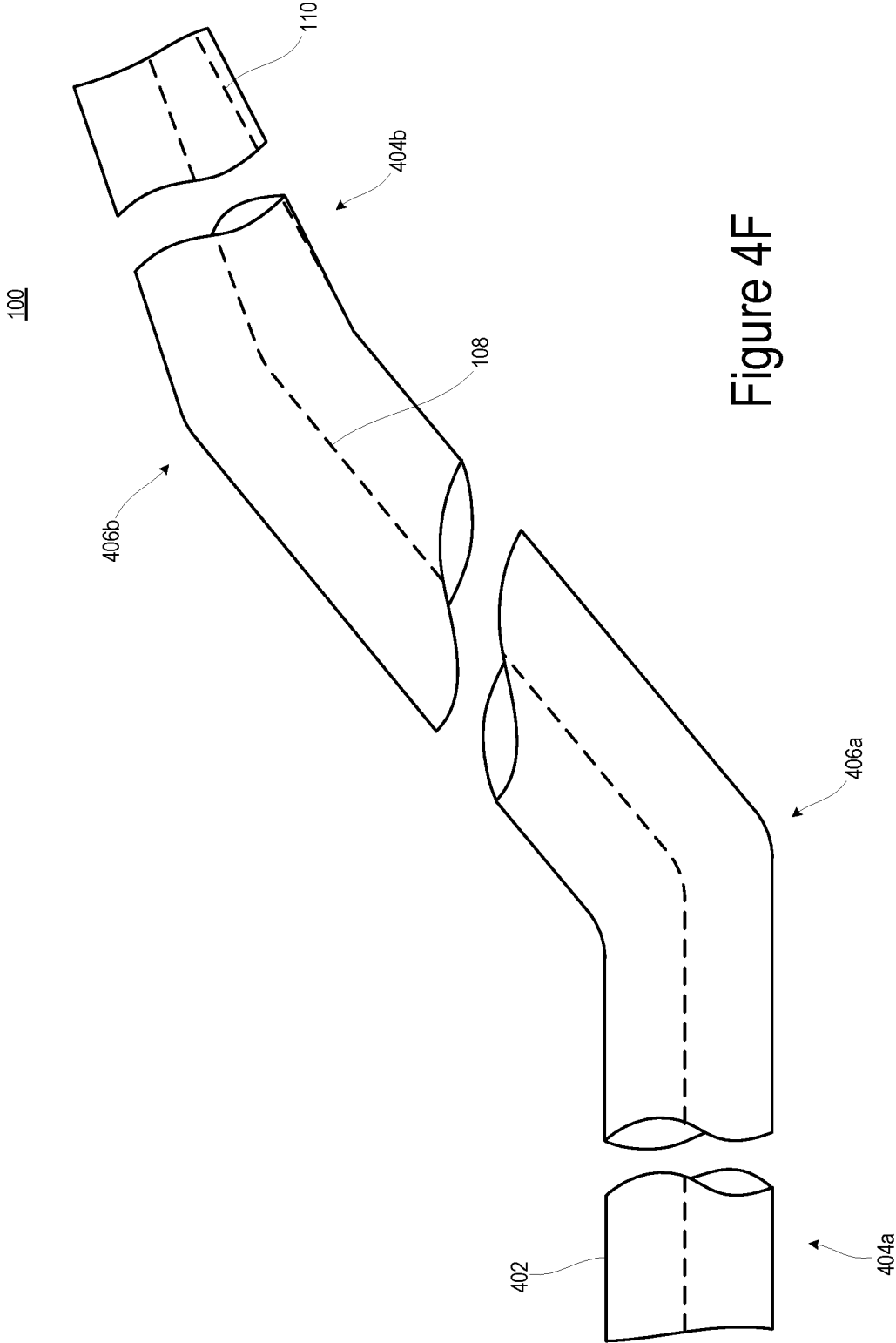

Figure 4F

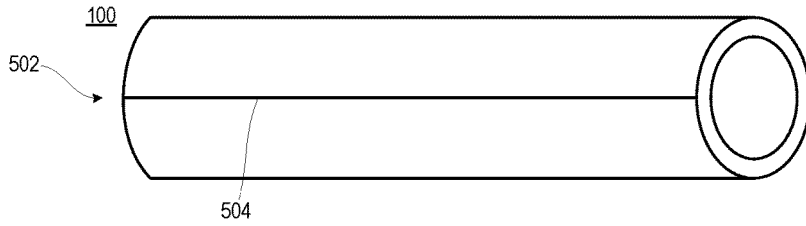

Figure 5A

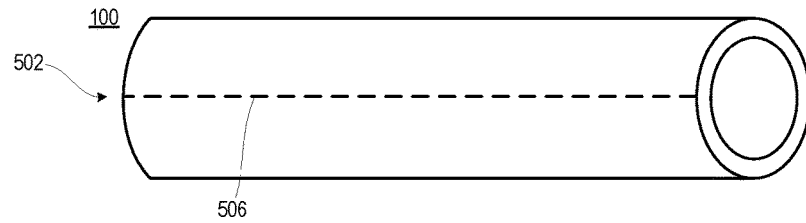

Figure 5B

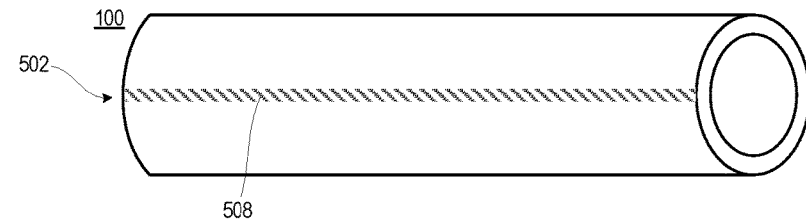

Figure 5C

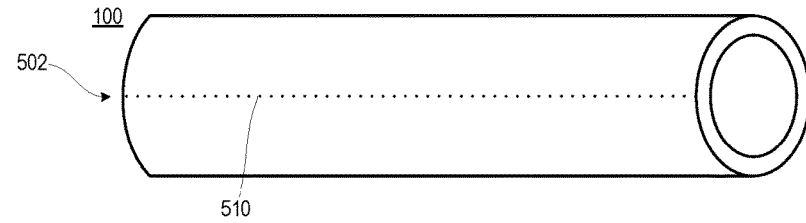

Figure 5D

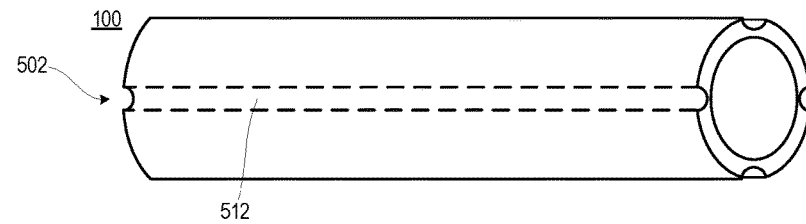

Figure 5E

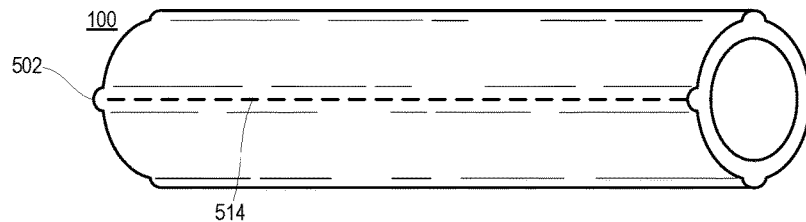

Figure 5F

MARKED CONDUIT OR TUBE

BACKGROUND

1. Field

[0001] The disclosure relates generally to conduits or tubes and, in particular embodiments, to marked conduits or tubes with a plurality of markings along a length dimension at various intervals to enable proper alignment of the conduits or tubes during bending.

2. Background

[0002] Conduits, such as pipes, are commonly used to house wires, fiber optics, and fluids. They are often times bent to fit the shape of the environment, such as within walls or around corners or the structure of the object. Tubes are commonly used as structural elements in objects such as bicycles frames or parasails and are bent to create the structure of the object. Current techniques of bending a conduit or tube include using a hand bender or a hydraulic bender, where the user inserts the conduit or tube into a cylindrical opening and bends the conduit or tube to produce bends of various angles. Other techniques of bending a conduit or tube include bending with the knees or hands and judging the bends by eye. These techniques may frequently result in “dog-legging,” which occurs when two or more bends on the conduit or tube are misaligned and are not straight within a plane or on or within walls or ceilings. Misalignment often results in difficulties in installing the conduits or tubes, especially on or within walls or ceilings, and often results in disposal and waste of the misaligned conduit or tube.

SUMMARY

[0003] Embodiments of the present disclosure relate to a marked conduit or tube that includes a plurality of markings on the outer surface of a hollow body along the length dimension of the marked conduit or tube to enable proper alignment of the conduit or tube during bending.

[0004] According to various embodiments, a marked conduit or tube includes: a hollow body having an outer surface, a length dimension, and a plurality of markings along the length dimension, the plurality of markings including a first line marking, where the first line marking is positioned at a 0-degree point of a cross-sectional view of the hollow body, a second line marking where the second line marking is positioned at a 90-degree point relative to the 0-degree point of the cross-sectional view of the hollow body, a third line marking, where the third line marking is positioned at a 180-degree point relative to the 0-degree point of the cross-sectional view of the hollow body, and a fourth line marking, where the fourth line marking is positioned at a 270-degree point relative to the 0-degree point of the cross-sectional view of the hollow body.

[0005] In some embodiments, the hollow body is cylindrical in shape and has a round cross section.

[0006] In some embodiments, the hollow body is oval in shape and has an oval cross section.

[0007] In some embodiments, the plurality of markings extends along the entire length of the length dimension.

[0008] In some embodiments, the plurality of markings extends along a portion of the length dimension.

[0009] In some embodiments, the marked conduit or tube includes a hollow interior for use as a structural component or for housing a material, the material comprises at least one of wires, fiber optics, or fluids.

[0010] In some embodiments, the hollow body has a diameter of any size up to 12 inches for housing a material, the material includes at least one of wires, fiber optics, or fluids.

[0011] In some embodiments, the marked conduit or tube is made of a rigid but bendable material to allow the marked conduit or tube to be bent at various angles.

[0012] In some embodiments, the plurality of markings includes one or more additional line markings on the outer surface of the marked conduit or tube, where the additional line markings are parallel to the first, second, third, and fourth line markings.

[0013] In some embodiments, the additional line markings are positioned at any 1-degree increments relative to the 0-degree point of the cross-sectional view of the hollow body.

[0014] In some embodiments, the first, second, third, and fourth line markings are identical in color and design, and additional line markings are distinguishable from the first, second, third, and fourth line markings by color or design.

[0015] In some embodiments, the first, second, third, and fourth line markings are any color such as red, blue, green, or yellow, and the additional line markings are different colors than the first, second, third, and fourth line markings.

[0016] In some embodiments, the hollow body is designed so the first, second, third, fourth, and additional line markings are painted, drawn, printed, etched, or ridged onto the outer surface in designs such as solid lines, dotted lines, dashed lines, or double solid lines.

[0017] In some embodiments, the length dimension of the hollow body is a length that allows the marked conduit to be bent two or more times.

[0018] According to various embodiments, there is provided a method of manufacturing a marked conduit or tube, the method including: providing a hollow body having an outer surface and a length dimension, marking the outer surface of the hollow body with a plurality of markings, the plurality of markings including a first line marking, where the first line marking is positioned at a 0-degree point of a cross-sectional view of the hollow body, a second line marking, where the second line marking is positioned at a 90-degree point relative to the 0-degree point of the cross-sectional view of the hollow body, a third line marking, where the third line marking is positioned at a 180-degree point relative to the 0-degree point of the cross-sectional view of the hollow body, and a fourth line marking, where the fourth line marking is positioned at a 270-degree point relative to the 0-degree point of the cross-sectional view of the hollow body.

[0019] In some embodiments, the method further includes marking the outer surface of the hollow body by painting, printing, etching or ridging a plurality of marks on the outer surface.

[0020] In some embodiments, the method further includes marking additional line markings at any 1-degree increments relative to the 0-degree point of the cross-sectional view of the hollow body.

[0021] In some embodiments, the method further includes marking the additional line markings in a different color than or in a different design than the first, second, third, and

fourth line markings, the different designs comprising any combination of solid lines, dotted lines, dashed lines, or double solid lines.

[0022] According to various embodiments, there is provided a method of bending a marked conduit or tube, the method including: providing a marked conduit or tube including a hollow body having an outer surface, a length dimension, and a plurality of markings along the length dimension, the plurality of markings including a first line marking, where the first line marking is positioned at a 0-degree point of a cross-sectional view of the hollow body, a second line marking, where the second line marking is positioned at a 90-degree point relative to the 0-degree point of the cross-sectional view of the hollow body, a third line marking, where the third line marking is positioned at a 180-degree point relative to the 0-degree point of the cross-sectional view of the hollow body, and a fourth line marking, where the fourth line marking is positioned at a 270-degree point relative to the 0-degree point of the cross-sectional view of the hollow body, and bending the marked conduit or tube two times, such that only one of the first, second, third, or fourth line markings is visible when a straight portion before a first bend and a straight portion after a second bend are lying flat on a plane, and aligning the marked conduit or tube such that the line markings are equidistant from the edges of the marked conduit or tube lying flat on a plane through the straight portions before and after the bends.

[0023] In some embodiments, the method further includes aligning the marked conduit or tube such that the line markings are equidistant from the edges of the marked conduit or tube through the straight portions before the first bend and after the second bend, when the marked conduit or tube is lying flat on a plane.

BRIEF DESCRIPTION OF THE DRAWINGS

[0024] The foregoing and other objects, aspects, features, and advantages of the disclosure will become more apparent and better understood by referring to the following description taken in conjunction with the accompanying drawings, in which:

[0025] FIG. 1 is a perspective view of a marked conduit or tube according to various embodiments;

[0026] FIG. 2 is a perspective view of a marked conduit or tube with additional line markings according to various embodiments;

[0027] FIG. 3A is a cross-sectional view of a cylindrical marked conduit or tube according to various embodiments;

[0028] FIG. 3B is a cross-sectional view of an oval-shaped marked conduit or tube according to various embodiments;

[0029] FIG. 3C is a cross-sectional view of a cylindrical marked conduit or tube with additional line markings according to various embodiments;

[0030] FIG. 3D is a cross-sectional view of an oval-shaped marked conduit or tube with additional line markings according to various embodiments;

[0031] FIG. 4A is a top view of a marked conduit or tube with properly aligned bends according to various embodiments;

[0032] FIG. 4B is a top view of a marked conduit or tube with properly aligned bends according to various embodiments;

[0033] FIG. 4C is a top view of a marked conduit or tube with properly aligned bends according to various embodiments;

[0034] FIG. 4D is a top view of a marked conduit or tube with a “dog leg” according to various embodiments;

[0035] FIG. 4E is a top view of a marked conduit or tube with a “dog leg” according to various embodiments;

[0036] FIG. 4F is a top view of a marked conduit or tube with a “dog leg” according to various embodiments;

[0037] FIG. 5A is a side view of a marked conduit or tube with a plurality of markings printed on the marked conduit or tube in the design of a solid line according to various embodiments;

[0038] FIG. 5B is a side view of a marked conduit or tube with a plurality of markings printed on the marked conduit or tube in the design of a dashed line according to various embodiments;

[0039] FIG. 5C is a side view of a marked conduit or tube with a plurality of markings printed on the marked conduit or tube in the design of a diagonally dashed line according to various embodiments;

[0040] FIG. 5D is a side view of a marked conduit or tube with a plurality of markings printed on the marked conduit or tube in the design of a dotted line according to various embodiments;

[0041] FIG. 5E is a side view of a marked conduit or tube with a plurality of markings etched into the marked conduit or tube according to various embodiments; and

[0042] FIG. 5F is a side view of a marked conduit or tube with a plurality of markings ridged onto the marked conduit or tube according to various embodiments.

[0043] The features of embodiments will become more apparent from the detailed description set forth below when taken in conjunction with the drawings, in which like reference characters identify corresponding elements throughout. In the drawings, like reference numbers generally indicate identical, functionally similar, or structurally similar elements.

DETAILED DESCRIPTION

[0044] According to various embodiments of the invention, a marked conduit or tube includes a plurality of markings on the outer surface of a hollow body along a length dimension of the marked conduit to enable proper alignment during bending. In the following description, “conduit” and “tube” may be used interchangeably. FIG. 1 is a perspective view of a marked conduit 100 according to various embodiments. In particular embodiments, the marked conduit 100 includes a hollow body 102 having an outer surface 106, a length dimension L, and a plurality of markings 104 parallel to the central axis A and along the length dimension L.

[0045] The marked conduit 100 is shown with labels identifying a center axis A and a plurality of radii r1, r2, r3, and r4, each extending from the center axis A to locations at the outer circumference of the hollow body 102 of the marked conduit 100. The center axis A extends along the length dimension L of the hollow body 102, at the center of the circular cross section shape of the hollow body 102. The plurality of markings 104 may include a first line marking 108, a second line marking 110, a third line marking 112, and a fourth line marking 114.

[0046] Referring to FIG. 1, the second line marking 110 and the third line marking 114 are shown as dots on the outer surface 106 of the marked conduit 100 where the line markings would be located. Each of the line markings defines a line that extends along the length dimension L of

the hollow body **102**, parallel to the central axis A. The first line marking **108**, second line marking **110**, third line marking **112**, and fourth line marking **114** are on the outer surface **106** of the marked conduit **100** such that each line marking is located at 90-degree intervals along the outer circumference of the hollow body **102** of the marked conduit **100**. For example, when the hollow body **102** is arranged such that the first line marking **108** is at 0 degrees, the second line marking **110** will be at 90 degrees (the 90-degree angle formed by radii **r1** and **r2**), the third line marking **112** will be at 180 degrees (the 90-degree angle formed by radii **r2** and **r3**), and the fourth line marking **114** will be at 270 degrees (the 90-degree angle formed by radii **r3** and **r4**).

[0047] FIG. 2 is a perspective view of a marked conduit **100** with additional line markings **216** according to various embodiments of the invention. Features described with respect to the embodiments of FIG. 2 can be employed in other embodiments including, but not limited to, embodiments described with respect to FIG. 1. The same reference numbers as employed in previously described embodiments are used for corresponding features of the embodiments of FIG. 2.

[0048] Referring to FIG. 2, in some embodiments, the marked conduit **100** is shown with labels identifying a center axis A and a plurality of radii **r1**, **r2**, **r3**, **r4**, **r5**, **r6**, **r7** and **r8**, extending from the center axis A to locations at the outer circumference of the hollow body **102** of the marked conduit **100**. The center axis A extends along the length dimension L of the hollow body **102**, at the center of the circular cross section shape of the hollow body **102**. The plurality of markings **104** may include a first line marking **108**, a second line marking **110**, a third line marking **112**, a fourth line marking **114**, and additional line markings **216** that are parallel to the first **108**, second **110**, third **112**, and fourth line markings **114**. In some embodiments, the first line marking **108**, second line marking **110**, third line marking **112**, and fourth line marking **114** are on the outer surface **106** of the marked conduit **100** such that each line marking is located at 90-degree intervals along the outer circumference of the hollow body **102**, as described in a previous embodiment. Each of the line markings defines a line that extends along the length dimension L of the hollow body **102**, parallel to the central axis A.

[0049] In some embodiments, the additional line markings **216** may include line markings in groups of four, which are distinguishable from the first **108**, second **110**, third **112**, and fourth line markings **114** by color or design. For example, one embodiment may include a fifth line marking **218**, a sixth line marking **220**, a seventh line marking **222**, and an eighth line marking **224**. The additional line markings **216** may be located on the outer surface **106** such that the additional line markings are located at 90-degree intervals from each other. For example, when the hollow body **102** is arranged such that the fifth line marking **218** is held at 30 degrees, the sixth line marking **220** will be at 120 degrees (the 90-degree angle formed by radii **r5** and **r6**), the seventh line marking **222** will be at 210 degrees (the 90-degree angle formed by radii **r6** and **r7**), and the eighth line marking **224** will be at 300 degrees (the 90-degree angle formed by radii **r7** and **r8**).

[0050] In some embodiments, the plurality of markings **104** of the marked conduit **100** may include any number of additional line markings **216**. The additional line markings **216** may be located at any suitable distance from adjacent

markings, such as, but not limited to, 5-degree increments relative to the 0-degree point of the cross-sectional view of the hollow body **102**. In other embodiments, the distance between adjacent markings may be 1-degree, 2-degrees, 3-degrees, 10-degrees, etc. The presence of too many additional line markings **216** may make it difficult to follow a single line marking along the length dimension L of the marked conduit **100**. Accordingly, in further embodiments, groups of additional line markings **216** may be distinguishable in any of the following ways: color, design, or pattern. Distinguishable additional line markings **216** in accordance with embodiments of the invention are discussed further below.

[0051] In some embodiments, additional line markings **216** may include line markings in groups of two or three, with each group being distinguishable from the first **108**, second **110**, third **112**, and fourth **114** line markings by color or design. For example, the first **108**, second **110**, third **112**, and fourth **114** line markings may all be blue while the fifth **218**, sixth **220**, seventh **222**, and eighth **224** line markings may all be red.

[0052] In various embodiments, the hollow body **102** of the marked conduit **100** may be cylindrical in shape with a round cross section. In other embodiments, the hollow body **102** of the marked conduit **100** may be oval in shape with an oval cross section. In still further embodiments, the hollow body **102** of the marked conduit **100** may be any suitable shape that allows the marked conduit **100** to be bent at various angles.

[0053] In various embodiments, the hollow body **102** of the marked conduit **100** may have a diameter of any suitable size for housing material such as wires, fiber optics, and fluids and also for bending. In other embodiments, the hollow body **102** of the marked tube **100** may have a diameter of any suitable size for serving as a structural element for objects such as bicycle frames or parasails. In some embodiments, the diameter of the hollow body **102** may be any size up to 12 inches, such as ½ inch, ¾ inch, 1 inch, 1¼ inches, 1½ inches, 2 inches, 2½ inches, 3 inches, or 4 inches. In other embodiments, the diameter of the hollow body **102** may be any size up to 24 inches.

[0054] In some embodiments, the marked conduit **100** may include a hollow body **102** with a length dimension L of any suitable length to allow for bending of the marked conduit **100**. In one embodiment, the marked conduit **100** may have a length dimension L suitable for bending the marked conduit **100** two times. In other embodiments, the marked conduit **100** may have a length dimension L suitable for bending the marked conduit **100** more than two times.

[0055] In some embodiments, the marked conduit **100** may be made from any suitable rigid, but bendable, material, such as, but not limited to, cast iron, brass, steel, plastic, polyvinyl chloride (PVC), chlorinated polyvinyl chloride (CPVC), PEX (cross-linked polyethylene), nylon, galvanized steel, electrical metallic tubing (EMT), rigid metal conduit, and/or the like. In other embodiments, the marked conduit **100** may be made from any suitable rigid, but bendable, material for housing material such as wires, fiber optics, and fluids. In further embodiments, the marked tube **100** may be made from any suitable rigid, but bendable, material for use as structural elements.

[0056] FIGS. 3A-3D are cross-sectional views of marked conduits **100** showing the locations of the plurality of markings **104** according to various embodiments of the

invention. The locations of line markings are shown with dots on the edges of the marked conduits **100**. Features described with respect to embodiments of FIGS. 3A-3D can be employed in other embodiments including, but not limited to, embodiments described with respect to FIGS. 1-2. The same reference numbers as employed in previously described embodiments are used for corresponding features of the embodiments of FIGS. 3A-3D.

[0057] Referring to FIGS. 3A and 3B, the marked conduit **100** is shown with labels identifying a center axis A and a plurality of radii **r1**, **r2**, **r3**, and **r4**, each extending from the center axis A to locations at the outer circumference of the hollow body **102** of the marked conduit **100**. The outer surface **106** of the hollow body **102** may include the first line marking **108**, second line marking **110**, third line marking **112**, and fourth line marking **114** spaced at 90-degree intervals along the outer circumference of the hollow body **102**. For example, when the cross-section is arranged such that the first line marking **108** is held at 0 degrees, the second line marking **110** will be at 90 degrees (the 90-degree angle formed by radii **r1** and **r2**), the third line marking **112** will be at 180 degrees (the 90-degree angle formed by radii **r2** and **r3**), and the fourth line marking **114** will be at 270 degrees (the 90-degree angle formed by radii **r3** and **r4**).

[0058] Referring to FIGS. 3C and 3D, the marked conduit **100** is shown with labels identifying a center axis A and a plurality of radii **r1**, **r2**, **r3**, **r4**, **r5**, **r6**, **r7** and **r8**, each extending from the center axis A to locations at the outer circumference of the hollow body **102** of the marked conduit **100**. The outer surface **106** of the hollow body **102** may include the first line marking **108**, second line marking **110**, third line marking **112**, and fourth line marking **114** spaced at 90-degree intervals along the outer circumference of the hollow body **102**, as shown in previously described embodiments.

[0059] In some embodiments, the outer surface **106** may also include additional line markings **216**. The additional line markings **216** may include a fifth line marking **218**, a sixth line marking **220**, a seventh line marking **222**, and an eighth line marking **224**, each at 90-degree intervals from each other. For example, when the cross-section is arranged such that the fifth line marking **218** is held at 30 degrees, the sixth line marking **220** will be at 120 degrees (the 90-degree angle formed by radii **r5** and **r6**), the seventh line marking **222** will be at 210 degrees (the 90-degree angle formed by radii **r6** and **r7**), and the eighth line marking **224** will be at 300 degrees (the 90-degree angle formed by radii **r7** and **r8**).

[0060] In further embodiments, the plurality of markings **104** of the marked conduit **100** may include any number of additional line markings **216**. The additional line markings **216** may be located at any suitable distance from adjacent markings, such as, but not limited to, 5-degree increments relative to the 0-degree point of the cross-sectional view of the hollow body **102**. In other embodiments, the distance between adjacent markings may be 1-degree, 2-degrees, 3-degrees, 10-degrees, etc. In other embodiments, additional line markings **216** may include line markings in groups of two, three, or four, with each group being distinguishable from the first **108**, second **110**, third **112**, and fourth **114** line markings by color or design. For example, the first **108**, second **110**, third **112**, and fourth **114** line markings may all be blue while the fifth **218**, sixth **220**, seventh **222**, and eighth **224** line markings may all be red. Distinguishable

additional line markings **216** in accordance with embodiments of the invention are discussed further below.

[0061] FIGS. 4A-4F are top views of a marked conduit **100** that has two bends in the same plane. FIGS. 4A-4C are top views of a marked conduit **100** with a properly aligned first bend **406a** and second bend **406b**. FIGS. 4D-4F are top views of a marked conduit **100** with an improperly aligned first bend **406a** and second bend **406b**, resulting in a “dog leg.” Features described with respect to the embodiments of FIGS. 4A-4F can be employed in other embodiments including, but not limited to, embodiments described with respect to FIGS. 1-3D. The same reference numbers as employed in previously described embodiments are used for corresponding features of the embodiments of FIGS. 4A-4F.

[0062] Referring to FIGS. 4A-4C, in some embodiments, the marked conduit **100** may have a first bend **406a** with a straight portion of the hollow body before the first bend **404a** and a second bend **406b** with a straight portion of the hollow body after the second bend **404b**. In other embodiments, the marked conduit **100** may also have a first line marking **108**. The first line marking **108** may extend along the entire length dimension L of the marked conduit **100** or may only extend along a portion of the length dimension L.

[0063] When the marked conduit **100** has a properly aligned first bend **406a** and second bend **406b** in the same plane, the first line marking **108** will be visible from a top view at a location equidistant from the edge **402** of the marked conduit **100** from the straight portion of the hollow body before the first bend **404a**, through the first **406a** and second **406b** bends and to the straight portion of the hollow body after the second bend **404b**. For example, for the marked conduit **100** with a properly aligned first bend **406a** and second bend **406b** in the same plane, the first line marking **108** will remain centered in a single plane along its length (e.g., the plane of the sheet of the drawings of FIGS. 4A-C), from the straight portion of the hollow body before the first bend **404a**, through the first bend **406a** and second bend **406b**, and to the straight portion of the hollow body after the second bend **404b**.

[0064] In other words, referring to FIGS. 4A and 4C where the first bend **406a** and the second bend **406b** are properly aligned in the same plane, when the marked conduit **100** is positioned in front of the user such that the straight portion before the first bend **404a**, and the straight portion after the second bend **404b** are extending outwards directly in front of the user, the first line marking **108** will remain in a straight line through both bends on the marked conduit **100**.

[0065] In other embodiments, the marked conduit **100** may have properly aligned bends that are not in the same plane. For example, the marked conduit **100** may be bent such that the straight portion before the first bend **406a** and the straight portion after the second bend **406b** are extending into planes that are perpendicular to each other. When the marked conduit **100** has a first bend **406a** and a second bend **406b** such that the straight portion before the first bend **404a** and the straight portion after the second bend **404b** are extending into perpendicular planes, the user may use the line markings as visual guides to create 90-degree bends. The user may also rotate the marked conduit **100** to view the bends from different perspectives and may use the line markings as visual guides from different perspectives to ensure that the bends are at 90-degree angles.

[0066] Referring to FIGS. 4D-4F, in other embodiments, the marked conduit **100** may have a first bend **406a** with a

straight portion of the hollow body before the first bend **404a** and a second bend **406b** with a straight portion of the hollow body after the second bend **404b**. In some embodiments, the marked conduit **100** may also have a first line marking **108** and a second line marking **110**. The first line marking **108** and the second line marking **110** may extend along the entire length dimension L of the marked conduit **100** or may only extend along a portion of the length dimension L.

[0067] When the marked conduit **100** has an improperly aligned first bend **406a** and second bend **406b**, the first line marking **108** will not remain centered and equidistant from the edge **402** of the marked conduit **100** from the straight portion of the hollow body before the first bend **404a**, through the first **406a** and second **406b** bends, and to the straight portion of the hollow body after the second bend **404b**. For example, for the marked conduit **100** with an improperly aligned first bend **406a** and second bend **406b**, the first line marking **108** will not remain centered and will not remain in a single plane (e.g., the plane of the sheet of the drawings of FIGS. 4D-F), from the straight portion of the hollow body before the first bend **404a**, through the first **406a** and second **406b** bends, and to the straight portion of the hollow body after the second bend **404b**. In addition, the second line marking **110** may become visible. In other words, when the marked conduit **100** has a “dog leg,” the first line marking **108** will not remain centered through the first bend **406a** and second bend **406b**.

[0068] In other words, referring to FIGS. 4D and 4F where the first bend **406a** and second bend **406b** are improperly aligned, when the marked conduit **100** is positioned in front of the user such that the straight portion before the first bend **404a** is extending outwards directly in front of the user, the first line marking **108** will remain in a straight line from the straight portion before the first bend **404a** to the second bend **406b**, but will angle to the side through the straight portion after the second bend **404b**.

[0069] In other embodiments, the marked conduit **100** may have improperly aligned bends that are not in the same plane. For example, the marked conduit **100** may be bent such that the straight portion before the first bend **406a** and the straight portion after the second bend **406b** are extending into planes that are perpendicular to each other. When the marked conduit **100** has a first bend **406a** and a second bend **406b** such that the straight portion before the first bend **404a** and the straight portion after the second bend **404b** are extending into perpendicular planes, the user may use the line markings as visual guides to create 90-degree bends that are properly aligned. When the 90-degree bends are improperly aligned, the line markings will not form 90-degree angles. The user may also rotate the marked conduit **100** to view the bends from different perspectives and may use the line markings as visual guides from different perspectives to ensure that the bends are at 90-degree angles.

[0070] Referring to FIGS. 4A-4F, in various embodiments, the marked conduit **100** may include pre-formed bends or may be straight (without bends). A user may use the plurality of line markings as a visual guide when bending or unbending (or further bending or unbending) the marked conduit **100**, so that the straight portion before the first bend **404a** and the straight portion after the second bend **404b** are properly aligned. In other embodiments, the marked conduit **100** may have any number of bends greater than two.

[0071] FIGS. 5A-5F are side views of a marked conduit **100** with line markings of various designs according to

various embodiments of the invention. The plurality of line markings **502** may be made by any suitable marking mechanism. Referring to FIGS. 5A-5D, in some embodiments, the plurality of line markings **502** may be printed, drawn, or painted along the length dimension L. The design of the plurality of line markings **502** may be a solid line **504**, a dashed line **506**, a diagonal dashed line **508**, a dotted line **510** or any other design suitable for forming a line marking, such as a double solid line. In other embodiments, the plurality of line markings may be a combination of different designs.

[0072] Referring to FIG. 5E, in one embodiment, the plurality of line markings **502** may be etched along the length dimension L. The design of the etched line marking **512** may be a solid line, a dashed line, a diagonal dashed line, a dotted line, or any other design suitable for forming a line marking such as a double solid line. The plurality of line markings **502** may also be a combination of different etched designs. The marks may be lightly etched so as not to alter the structural integrity of the marked conduit **100**, but discernable enough to see the etched marks upon closer examination when bending the marked conduit **100**.

[0073] Referring to FIG. 5F, in another embodiment, the plurality of line markings **502** may be ridged along the length dimension L. The design of the ridged line markings **514** may be a solid line, a dashed line, a diagonal dashed line, a dotted line, or any other design suitable for forming a ridged line marking such as a double solid line. The plurality of line markings **502** may also be a combination of different ridged designs.

[0074] In particular embodiments, the plurality of line markings **502** may extend along the entire length of the length dimension L. In other embodiments, the plurality of line markings **502** may extend along only a portion of the length dimension L. In still further embodiments, the plurality of line markings **502** may be located at repeating intervals along portions of the length dimension L.

[0075] The embodiments disclosed herein are to be considered in all respects as illustrative, and not restrictive of the invention. The present invention is in no way limited to the embodiments described above. Various modifications and changes may be made to the embodiments without departing from the spirit and scope of the invention. The scope of the invention is indicated by the attached claims, and their equivalents, rather than the embodiments. Various modifications and changes that come within the meaning and range of equivalency of the claims are intended to be within the scope of the invention.

1. A marked conduit or tube comprising:
 - a hollow body having an outer surface, a length dimension, and a plurality of markings along the length dimension, the plurality of markings comprising:
 - a first line marking, wherein the first line marking is positioned at a 0-degree point of a cross-sectional view of the hollow body;
 - a second line marking, wherein the second line marking is positioned at a 90-degree point relative to the 0-degree point of the cross-sectional view of the hollow body;
 - a third line marking, wherein the third line marking is positioned at a 180-degree point relative to the 0-degree point of the cross-sectional view of the hollow body; and

- a fourth line marking, wherein the fourth line marking is positioned at a 270-degree point relative to the 0-degree point of the cross-sectional view of the hollow body;
- wherein the outer surface of the hollow body is devoid of further line markings that extend along the entire length dimension of the hollow body.
2. The marked conduit or tube of claim 1 wherein the hollow body is cylindrical in shape and comprises a round cross section.
3. The marked conduit or tube of claim 1 wherein the hollow body is oval in shape and comprises an oval cross section.
4. The marked conduit or tube of claim 1 wherein the plurality of markings extends along the entire length of the length dimension.
5. The marked conduit or tube of claim 1 wherein the hollow body is made of a bendable material that allows the hollow body to be bent to form a first bend and a second bend along a portion of the length dimension such that only one of the first, second, third, or fourth line markings is visible on top of the hollow body when a straight portion before a first bend and a straight portion after a second bend are lying flat on a plane.
6. The marked conduit or tube of claim 1 wherein the marked conduit or tube comprises a hollow interior for use as a structural component or for housing a material, the material comprises at least one of wires, fiber optics, or fluids.
7. The marked conduit or tube of claim 1 wherein the hollow body has a diameter of any size up to 12 inches for housing a material, the material comprises at least one of wires, fiber optics, or fluids.
8. The marked conduit or tube of claim 7 wherein the marked conduit or tube is made of a rigid but bendable material to allow the marked conduit or tube to be bent at various angles.
9. The marked conduit or tube of claim 1 wherein the plurality of markings comprises one or more additional line markings on the outer surface of the marked conduit or tube, wherein the additional line markings are parallel to the first, second, third, and fourth line markings.
10. The marked conduit or tube of claim 9, wherein the additional line markings are positioned at any 1-degree increments relative to the 0-degree point of the cross-sectional view of the hollow body.
11. The marked conduit or tube of claim 10, wherein the first, second, third, and fourth line markings are identical in color and design, and wherein additional line markings are distinguishable from the first, second, third, and fourth line markings by color or design.
12. The marked conduit or tube of claim 11, wherein the first, second, third, and fourth line markings are any color such as red, blue, green, or yellow, and wherein the additional line markings are different colors than the first, second, third, and fourth line markings.
13. The marked conduit or tube of claim 12, wherein the hollow body is designed so the first, second, third, fourth, and additional line markings are painted, drawn, printed, etched, or ridged onto the outer surface in designs such as solid lines, dotted lines, dashed lines, or double solid lines.
14. The marked conduit or tube of claim 1 wherein the hollow body is made of a bendable material and the length

dimension of the hollow body is a length that allows the marked conduit or tube to be bent two or more times along the length dimension.

15. A method of manufacturing a marked conduit or tube, the method comprising:
- providing a hollow body having an outer surface and a length dimension;
 - marking the outer surface of the hollow body with a plurality of markings, the plurality of markings comprising:
 - a first line marking, wherein the first line marking is positioned at a 0-degree point of a cross-sectional view of the hollow body;
 - a second line marking, wherein the second line marking is positioned at a 90-degree point relative to the 0-degree point of the cross-sectional view of the hollow body;
 - a third line marking, wherein the third line marking is positioned at a 180-degree point relative to the 0-degree point of the cross-sectional view of the hollow body; and
 - a fourth line marking, wherein the fourth line marking is positioned at a 270-degree point relative to the 0-degree point of the cross-sectional view of the hollow body;
 - wherein the outer surface of the hollow body is devoid of further line markings that extend along the entire length dimension of the hollow body.
16. The method of claim 15, wherein marking the outer surface of the hollow body is done by painting, printing, etching or ridging a plurality of marks on the outer surface.
17. The method of claim 15, wherein marking the outer surface with the plurality of markings further comprises marking additional line markings at any 1-degree increments relative to the 0-degree point of the cross-sectional view of the hollow body.
18. The method of claim 15, wherein marking the outer surface with the plurality of markings further comprises marking the additional line markings in a different color than or in a different design than the first, second, third, and fourth line markings, the different designs comprising any combination of solid lines, dotted lines, dashed lines, or double solid lines.
19. A method of bending a marked conduit or tube, the method comprising:
- providing a marked conduit or tube comprising a hollow body having an outer surface, a length dimension, and a plurality of markings along the length dimension, the plurality of markings comprising:
 - a first line marking, wherein the first line marking is positioned at a 0-degree point of a cross-sectional view of the hollow body;
 - a second line marking, wherein the second line marking is positioned at a 90-degree point relative to the 0-degree point of the cross-sectional view of the hollow body;
 - a third line marking, wherein the third line marking is positioned at a 180-degree point relative to the 0-degree point of the cross-sectional view of the hollow body; and
 - a fourth line marking, wherein the fourth line marking is positioned at a 270-degree point relative to the 0-degree point of the cross-sectional view of the hollow body; and

bending the marked conduit or tube two times such that only one of the first, second, third, or fourth line markings is visible when a straight portion before a first bend and a straight portion after a second bend are lying flat on a plane.

20. The method of claim **19**, further comprising aligning the marked conduit or tube such that the line markings are equidistant from the edges of the marked conduit lying flat on a plane through the straight portions before the first bend and after the second bend.

21. The marked conduit of claim **1** wherein the hollow body is made of a rigid but bendable material comprising at least one of cast iron, brass, steel, plastic, polyvinyl chloride (PVC), chlorinated polyvinyl chloride (CPVC), PEX (cross-linked polyethylene), nylon, galvanized steel, electrical metallic tubing (EMT), or rigid metal conduit.

22. The method of claim **15**, wherein providing a hollow body comprises providing a hollow body made of a rigid but bendable material comprising at least one of cast iron, brass, steel, plastic, polyvinyl chloride (PVC), chlorinated polyvinyl chloride (CPVC), PEX (cross-linked polyethylene), nylon, galvanized steel, electrical metallic tubing (EMT), or rigid metal conduit.

23. The method of claim **15**, wherein providing the hollow body comprises providing a hollow tube structure made of a bendable material that allows the hollow tube structure to be bent to form a first bend and a second bend such that only one of the first, second, third, or fourth line markings is visible on top of the hollow body when a straight portion before a first bend and a straight portion after a second bend are lying flat on a plane.

* * * * *