

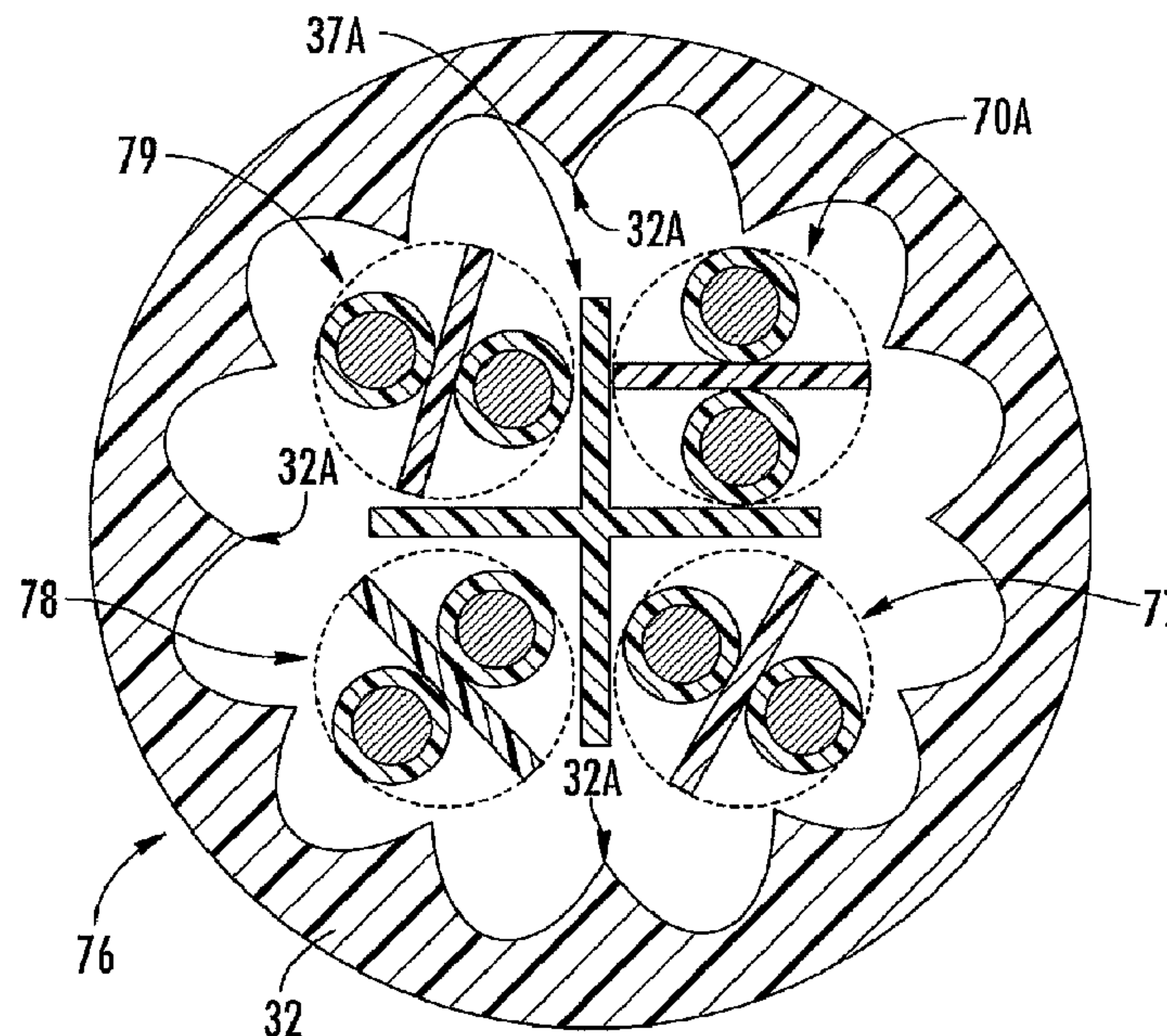

(86) **Date de dépôt PCT/PCT Filing Date:** 2009/03/19
 (87) **Date publication PCT/PCT Publication Date:** 2009/09/24
 (45) **Date de délivrance/Issue Date:** 2016/12/20
 (85) **Entrée phase nationale/National Entry:** 2010/09/20
 (86) **N° demande PCT/PCT Application No.:** US 2009/037709
 (87) **N° publication PCT/PCT Publication No.:** 2009/117606
 (30) **Priorités/Priorities:** 2008/03/19 (US61/037,904);
 2009/03/19 (US12/407,407)

(51) **Cl.Int./Int.Cl. H01B 11/06** (2006.01)
 (72) **Inventeurs/Inventors:**
 WIEBELHAUS, DAVID ALLYN, US;
 HAYES, TRENT, US;
 HOPKINSON, WAYNE, US
 (73) **Propriétaire/Owner:**
 COMMSCOPE, INC. OF NORTH CAROLINA, US
 (74) **Agent:** NELLIGAN O'BRIEN PAYNE LLP

(54) **Titre : BANDE DE SEPARATION POUR PAIRE TORSADÉE DANS UN CABLE DE RESEAU LOCAL**
 (54) **Title: SEPARATOR TAPE FOR TWISTED PAIR IN LAN CABLE**



(57) **Abrégé/Abstract:**

First and second insulated conductors are twisted with a first dielectric tape residing therebetween to form a first twisted pair. A jacket surrounds the first twisted pair and optionally a similarly formed second twisted pair. In alternative or supplemental

(57) Abrégé(suite)/Abstract(continued):

embodiments, the first insulated conductor includes a conductor surrounded by insulating material having a radial thickness of about 7 mils or less; the first dielectric tape has a width which is equal to or less than the diameters of the first and second insulated conductors plus a thickness of the first dielectric tape; the first dielectric tape has a cross sectional shape with recesses seating the insulated conductors; twist lengths of the first and second twisted pairs are between approximately 0.22 to 0.38 inches and different from each other; the first dielectric tape is different in shape, size or material content as compared to a second dielectric tape of the second twisted pair; the insulated conductors of the first and second twisted pairs are identical in appearance, while the first and second dielectric tapes are different in appearance; and/or the first dielectric tape has a hollow core possessing a gas or material with a lower dielectric constant.

(12) INTERNATIONAL APPLICATION PUBLISHED UNDER THE PATENT COOPERATION TREATY (PCT)

CORRECTED VERSION

(19) World Intellectual Property Organization
International Bureau(43) International Publication Date
24 September 2009 (24.09.2009)(10) International Publication Number
WO 2009/117606 A8(51) International Patent Classification:
H01B 11/06 (2006.01)(21) International Application Number:
PCT/US2009/037709(22) International Filing Date:
19 March 2009 (19.03.2009)

(25) Filing Language: English

(26) Publication Language: English

(30) Priority Data:
61/037,904 19 March 2008 (19.03.2008) US(71) Applicant (for all designated States except US): **COMMScope, INC. OF NORTH CAROLINA** [US/US];
1100 Commscope Place, Se, Hickory, NC 28602 (US).

(72) Inventors; and

(75) Inventors/Applicants (for US only): **WIEBELHAUS, David, Allyn** [US/US]; 3731 Blendwood Lane Ne, Hickory, NC 28601 (US). **HAYES, Trent** [US/US]; 2831 2nd St Pl Nw, Hickory, NC 28601 (US). **HOPKINSON, Wayne** [US/US]; 4851 Woodwinds Dr. Ne, Hickory, NC 28601 (US).(74) Agents: **LOWE, Scott, L.** et al.; P.o. Box 1364, Fairfax, VA 22038 (US).

(81) Designated States (unless otherwise indicated, for every kind of national protection available): AE, AG, AL, AM, AO, AT, AU, AZ, BA, BB, BG, BH, BR, BW, BY, BZ, CA, CH, CN, CO, CR, CU, CZ, DE, DK, DM, DO, DZ, EC, EE, EG, ES, FI, GB, GD, GE, GH, GM, GT, HN, HR, HU, ID, IL, IN, IS, JP, KE, KG, KM, KN, KP, KR, KZ, LA, LC, LK, LR, LS, LT, LU, LY, MA, MD, ME, MG, MK, MN, MW, MX, MY, MZ, NA, NG, NI, NO, NZ, OM, PG, PH, PL, PT, RO, RS, RU, SC, SD, SE, SG, SK, SL, SM, ST, SV, SY, TJ, TM, TN, TR, TT, TZ, UA, UG, US, UZ, VC, VN, ZA, ZM, ZW.

(84) Designated States (unless otherwise indicated, for every kind of regional protection available): ARIPO (BW, GH, GM, KE, LS, MW, MZ, NA, SD, SL, SZ, TZ, UG, ZM, ZW), Eurasian (AM, AZ, BY, KG, KZ, MD, RU, TJ, TM), European (AT, BE, BG, CH, CY, CZ, DE, DK, EE, ES, FI, FR, GB, GR, HR, HU, IE, IS, IT, LT, LU, LV, MC, MK, MT, NL, NO, PL, PT, RO, SE, SI, SK, TR), OAPI (BF, BJ, CF, CG, CI, CM, GA, GN, GQ, GW, ML, MR, NE, SN, TD, TG).

Declarations under Rule 4.17:

[Continued on next page]

(54) Title: SEPARATOR TAPE FOR TWISTED PAIR IN LAN CABLE

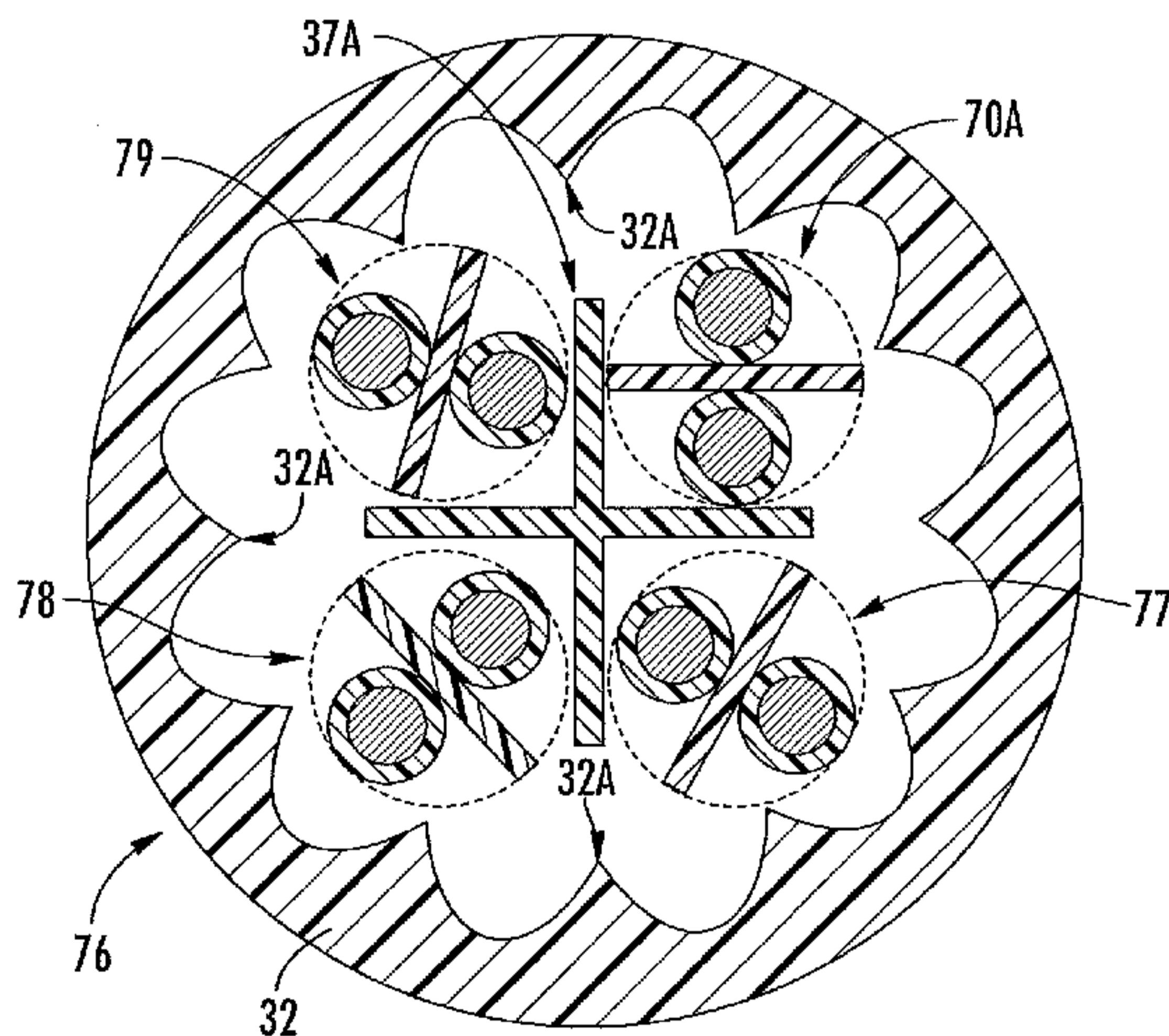

FIG. 8B

(57) Abstract: First and second insulated conductors are twisted with a first dielectric tape residing therebetween to form a first twisted pair. A jacket surrounds the first twisted pair and optionally a similarly formed second twisted pair. In alternative or supplemental embodiments, the first insulated conductor includes a conductor surrounded by insulating material having a radial thickness of about 7 mils or less; the first dielectric tape has a width which is equal to or less than the diameters of the first and second insulated conductors plus a thickness of the first dielectric tape; the first dielectric tape has a cross sectional shape with recesses seating the insulated conductors; twist lengths of the first and second twisted pairs are between approximately 0.22 to 0.38 inches and different from each other; the first dielectric tape is different in shape, size or material content as compared to a second dielectric tape of the second twisted pair; the insulated conductors of the first and second twisted pairs are identical in appearance, while the first and second dielectric tapes are different in appearance; and/or the first dielectric tape has a hollow core possessing a gas or material with a lower dielectric constant.

WO 2009/117606 A8 

- *as to the applicant's entitlement to claim the priority of the earlier application (Rule 4.17(iii))*
- Published:**
 - *with international search report (Art. 21(3))*
 - *with information concerning one or more priority claims considered void (Rule 26bis.2(d))*
- (48) Date of publication of this corrected version:**
12 November 2009
- (15) Information about Correction:**
see Notice of 12 November 2009

SEPARATOR TAPE FOR TWISTED PAIR IN LAN CABLE

[001] This application claims the benefit of U.S. Provisional Application No. 61/037,904, filed March 19, 2008, and to U.S. Application Serial No. 12/407,407.

BACKGROUND OF THE INVENTION

1. Field of the Invention

[002] The present invention relates to a twisted pair cable for communication of high speed signals, such as a local area network (LAN) cable. More particularly, the present invention relates to a twisted pair cable having a dielectric tape between first and second insulated conductors of a twisted pair.

2. Description of the Related Art

[003] As shown in Figures 1 and 2, the Assignee's prior U.S. Patent No. 6,506,976 shows a LAN cable 1 having a jacket J surrounding first through fourth twisted pairs A, B, C, D which are spaced from each other by a separator 3. Each of the twisted pairs A, B, C, D includes a first insulated conductor 5, a dielectric tape 7, and a second insulated conductor 9, wherein the first insulated conductor 5 is twisted with the second insulated conductor 9 with the dielectric tape 7 residing between the first insulated conductor 5 and the second insulated conductor 9.

[004] As best seen in the close-up cross sectional view of the twisted pair A in Figure 2, the width of the dielectric tape 7, which extends between opposing edges 11 and 13, is set to extend beyond the first and second insulated conductors 5 and 9. By this arrangement, the opposing edges 11 and 13 of the dielectric tape 7 circumscribe an area 15, around the twisted pairs A, B, C, D. The area 15 creates a spacing between the twisted pairs A, B, C, D and the separator 3 and between the twisted pairs A, B, C, D and the jacket J. This spacing around the twisted pairs A, B, C, D can improve the electrical performance of the cable 1, such as by reducing crosstalk.

[005] In typical cables of the background art, the first insulated conductor 5 would be formed by a first conductor 17 of about twenty-three gauge size, surrounded by a layer of a first dielectric insulating material 19 having a radial thickness greater than seven mils, such as about

tens mils or about eleven mils for a typical CAT 6 cable. Likewise, the second insulated conductor 9 would be formed by a second conductor 21 of about twenty-three gauge size, surrounded by a layer of a second dielectric insulating material 23 having a same or similar radial thickness.

SUMMARY OF THE INVENTION

[006] Although the cable of the background art performs well, Applicants have appreciated some drawbacks. Applicants have invented a twisted pair cable with new structural features, the object of which is to enhance one or more performance characteristics of a LAN cable, such as reducing insertion loss, matching impedance, reducing propagation delay and/or balancing delay skew between twisted pairs, and/or to enhance one or more mechanical characteristics of a LAN cable, such as improving flexibility, reducing weight, reducing cable diameter and reducing smoke emitted in the event of a fire.

[007] These and other objects are accomplished by a cable that includes a first insulated conductor, a first dielectric tape, and a second insulated conductor, wherein the first insulated conductor is twisted with the second insulated conductor with the first dielectric tape residing therebetween to form a first twisted pair. A jacket is formed around the first twisted pair. The cable may also include a third insulated conductor, a second dielectric tape, and a fourth insulated conductor, wherein the third insulated conductor is twisted with the fourth insulated conductor with the second dielectric tape residing therebetween to form a second twisted pair. If the second twisted pair is provided, the jacket is formed around both the first and second twisted pairs.

[008] In a first alternative or supplemental embodiment of the invention, the first insulated conductor includes a first conductor surrounded by a layer of first dielectric insulating material having a radial thickness of about 7 mils or less.

[009] In a second alternative or supplemental embodiment of the invention, the first dielectric tape is formed as a single unitary structure having a first width which extends approximately perpendicular to an extension length of the first twisted pair from a first edge of the first dielectric tape to a second edge of the first dielectric tape, wherein the first width is equal to or less than a diameter of the first insulated conductor plus a diameter of the second insulated conductor plus a thickness of the first dielectric tape.

[010] In a third alternative or supplemental embodiment of the invention, the first dielectric tape has a cross sectional shape in a direction perpendicular to the extension length of the first twisted pair, which presents a first recessed portion for seating the first insulated conductor and a second recessed portion for seating the second insulated conductor.

[011] In a fourth alternative or supplemental embodiment of the invention, a first twist length of the first twisted pair is between approximately 0.22 inches and approximately 0.38 inches, and a second twist length of the second twisted pair is different from the first twist length and is between approximately 0.22 inches and approximately 0.38 inches.

[012] In a fifth alternative or supplemental embodiment of the invention, the first dielectric tape is different in shape, size or material content as compared to the second dielectric tape.

[013] In a sixth alternative or supplemental embodiment of the invention, the first, second, third and fourth insulated conductors are identical in appearance, and the first dielectric tape is different in appearance from the second dielectric tape.

[014] In a seventh alternative or supplemental embodiment of the invention, the first dielectric tape has a hollow core possessing a gas or material with a lower dielectric constant than a material used to form the first dielectric tape.

[015] Further scope of applicability of the present invention will become apparent from the detailed description given hereinafter. However, it should be understood that the detailed description and specific examples, while indicating preferred embodiments of the invention, are given by way of illustration only, since various changes and modifications within the spirit and scope of the invention will become apparent to those skilled in the art from this detailed description.

BRIEF DESCRIPTION OF THE DRAWINGS

[016] The present invention will become more fully understood from the detailed description given hereinbelow and the accompanying drawings which are given by way of illustration only, and thus, are not limits of the present invention, and wherein:

[017] Figure 1 is a cross sectional view of a twisted pair cable, in accordance with the prior art;

[018] Figure 2 is a close-up cross sectional view of a twisted pair in the cable of Figure 1;

[019] Figure 3 is a perspective view of a twisted pair cable, in accordance with a first embodiment of the present invention;

[020] Figure 4 is a cross sectional view of the twisted pair cable of Figure 3 taken along line IV--IV;

[021] Figure 5 is a close-up cross sectional view of a twisted pair from Figure 4;

[022] Figure 5A is a close up cross sectional view of a twisted pair similar to Figure 5, but illustrating that the dielectric tape may include a hollow air pocket;

[023] Figure 6 is a close-up cross sectional view of a twisted pair, having a dielectric tape with an alternative shape, in accordance with a second embodiment of the present invention;

[024] Figure 7 is a cross sectional view of a twisted pair cable employing twisted pairs in accordance with Figure 6;

[025] Figure 8 is a close-up cross sectional view of a twisted pair, having a dielectric tape with an alternative shape, in accordance with a third embodiment of the present invention;

[026] Figure 8A is a close-up cross sectional view of a twisted pair, having a dielectric tape with an alternative shape, in accordance with a fourth embodiment of the present invention;

[027] Figure 8B is a cross sectional view of a twisted pair cable employing twisted pairs in accordance with Figure 8A;

[028] Figure 9 is a perspective view of a twisted pair cable, in accordance with a fifth embodiment of the present of the present invention;

[029] Figure 10 is a cross sectional view of the twisted pair cable of Figure 9 taken along line X--X;

[030] Figure 11 is a close-up cross sectional view of a twisted pair from Figure 10;

[031] Figure 12 is a close-up cross sectional view of a twisted pair, having a dielectric tape with an alternative shape, in accordance with a sixth embodiment of the present invention;

[032] Figure 13 is a close-up cross sectional view of a twisted pair, having a dielectric tape with an alternative shape, in accordance with a seventh embodiment of the present invention;

[033] Figure 14 is a cross sectional view of a twisted pair cable employing twisted pairs in accordance with Figure 13; and

[034] Figure 15 is a close-up cross sectional view of a twisted pair, having a dielectric tape with an alternative shape, in accordance with a eighth embodiment of the present invention.

DETAILED DESCRIPTION OF EMBODIMENTS OF THE INVENTION

[035] The present invention now is described more fully hereinafter with reference to the accompanying drawings, in which embodiments of the invention are shown. This invention may, however, be embodied in many different forms and should not be construed as limited to the embodiments set forth herein; rather, these embodiments are provided so that this disclosure will be thorough and complete, and will fully convey the scope of the invention to those skilled in the art.

[036] Like numbers refer to like elements throughout. In the figures, the thickness of certain lines, layers, components, elements or features may be exaggerated for clarity. Broken lines illustrate optional features or operations unless specified otherwise.

[037] The terminology used herein is for the purpose of describing particular embodiments only and is not intended to be limiting of the invention. Unless otherwise defined, all terms (including technical and scientific terms) used herein have the same meaning as commonly understood by one of ordinary skill in the art to which this invention belongs. It will be further understood that terms, such as those defined in commonly used dictionaries, should be interpreted as having a meaning that is consistent with their meaning in the context of the specification and relevant art and should not be interpreted in an idealized or overly formal sense unless expressly so defined herein. Well-known functions or constructions may not be described in detail for brevity and/or clarity.

[038] As used herein, the singular forms "a", "an" and "the" are intended to include the plural forms as well, unless the context clearly indicates otherwise. It will be further understood

that the terms "comprises" and/or "comprising," when used in this specification, specify the presence of stated features, integers, steps, operations, elements, and/or components, but do not preclude the presence or addition of one or more other features, integers, steps, operations, elements, components, and/or groups thereof. As used herein, the term "and/or" includes any and all combinations of one or more of the associated listed items. As used herein, phrases such as "between X and Y" and "between about X and Y" should be interpreted to include X and Y. As used herein, phrases such as "between about X and Y" mean "between about X and about Y." As used herein, phrases such as "from about X to Y" mean "from about X to about Y."

[039] It will be understood that when an element is referred to as being "on", "attached" to, "connected" to, "coupled" with, "contacting", etc., another element, it can be directly on, attached to, connected to, coupled with or contacting the other element or intervening elements may also be present. In contrast, when an element is referred to as being, for example, "directly on", "directly attached" to, "directly connected" to, "directly coupled" with or "directly contacting" another element, there are no intervening elements present. It will also be appreciated by those of skill in the art that references to a structure or feature that is disposed "adjacent" another feature may have portions that overlap or underlie the adjacent feature.

[040] Spatially relative terms, such as "under", "below", "lower", "over", "upper", "lateral", "left", "right" and the like, may be used herein for ease of description to describe one element or feature's relationship to another element(s) or feature(s) as illustrated in the figures. It will be understood that the spatially relative terms are intended to encompass different orientations of the device in use or operation in addition to the orientation depicted in the figures. For example, if the device in the figures is inverted, elements described as "under" or "beneath" other elements or features would then be oriented "over" the other elements or features. The device may be otherwise oriented (rotated 90 degrees or at other orientations) and the descriptors of relative spatial relationships used herein interpreted accordingly.

[041] Figure 3 is a perspective view of a twisted pair cable 31, in accordance with a first embodiment of the present invention. Figure 4 is a cross sectional view of the cable 31 taken along line IV--IV in Figure 3. The cable 31 includes a jacket 32 formed around and surrounding first, second, third and fourth twisted pairs 33, 34, 35 and 36, respectively. The jacket 32 may be formed of polyvinylchloride (PVC), low smoke zero halogen PVC, polyethylene (PE), fluorinated ethylene propylene (FEP), polyvinylidene fluoride (PVDF), ethylene chlorotrifluoroethylene (ECTFE), or other foamed or solid materials common to the cabling art.

[042] A separator 37 within the jacket 32 resides between and separates the first and fourth twisted pairs 33 and 36 from the second and third twisted pairs 34 and 35. In Figures 3 and 4, the separator 37 is formed by a thin strip of dielectric material, having a thickness of about twenty mils or less, more preferably eighteen mils or less, such as about fifteen mils. However, other sizes and shapes of separators 37 may be employed in combination with the present invention, such as plus-shaped or star-shaped separators, sometimes referred to as a flute, isolator, or cross-web. The separator 37 may be formed of any solid or foamed material common to the cabling art, such as a polyolefin or fluoropolymer, like fluorinated ethylene propylene (FEP) or polyvinylchloride (PVC).

[043] As best seen in the cross sectional view of Figure 4, the first twisted pair 33 includes a first insulated conductor 38, a first dielectric tape 39, and a second insulated conductor 40. The first insulated conductor 38 is twisted with the second insulated conductor 40, in a helical fashion, with the first dielectric tape 39 residing between the first insulated conductor 38 and the second insulated conductor 40.

[044] The second twisted pair 34 includes a third insulated conductor 41, a second dielectric tape 42, and a fourth insulated conductor 43. The third insulated conductor 41 is twisted with the fourth insulated conductor 43, in a helical fashion, with the second dielectric tape 42 residing between the third insulated conductor 41 and the fourth insulated conductor 43.

[045] The third twisted pair 35 includes a fifth insulated conductor 44, a third dielectric tape 45, and a sixth insulated conductor 46. The fifth insulated conductor 44 is twisted with the sixth insulated conductor 46, in a helical fashion, with the third dielectric tape 45 residing between the fifth insulated conductor 44 and the sixth insulated conductor 46.

[046] The fourth twisted pair 36 includes a seventh insulated conductor 47, a fourth dielectric tape 48, and an eighth insulated conductor 49. The seventh insulated conductor 47 is twisted with the eighth insulated conductor 49, in a helical fashion, with the fourth dielectric tape 48 residing between the seventh insulated conductor 47 and the eighth insulated conductor 49.

[047] Figure 5 is a close-up view of the first twisted pair 33, which is similarly constructed although not identically constructed (as will be detailed later in the specification) to the second, third and fourth twisted pairs 34, 35 and 36. Each of the first through eighth insulated conductors 38, 40, 41, 43, 44, 46, 47, 49 is formed by a conductor K surrounded by a layer of dielectric insulating material R, such as a polymer or foamed polymer, common to the cabling art

like fluorinated ethylene propylene (FEP), polyethylene (PE) or polypropylene (PP). Further, the insulating material R may be formed by an enamel coating, or another nonconductive coating from a diverse art like motor armature windings. The conductor K may be solid or stranded, and may be formed of a conductive metal or alloy, such as copper. In one embodiment, the conductor K is a solid, copper wire of about twenty three gauge size.

[048] In one embodiment, the insulating material R may have a radial thickness of about seven mils or less, more preferably about five mils or less. This radial thickness of the insulating layer R is at least 20% less than the standard insulation layer thickness of a conductor in a typical equivalent twisted pair wire, more preferably at least 25% to 30% less. Typically, such a thin insulation layer R would not be possible due to the incorrect impedance obtained when the conductors K of the first and second insulated conductors 38 and 40 become so closely spaced during the twisting operation due to the thinner insulating layers R. Typically, such thin insulation layers were not practiced in the background art, because there was no appreciation of a solution to the mechanical and performance problems. By the present invention, the interposed first dielectric tape 39 eases the mechanical stresses during twisting so that the thinner insulating layer R is undamaged and also spaces the conductors K apart so that a proper impedance may be obtained, e.g., one hundred ohms.

[049] As best seen in Figure 5, the first dielectric tape 39 has a first width which extends approximately perpendicular to an extension length of the first dielectric tape 39 from a first edge 51 of the first dielectric tape 39 to an opposing second edge 53 of the first dielectric tape 39. The first width is less than a diameter of the first insulated conductor 38 plus a diameter of the second insulated conductor 40 plus a thickness of the first dielectric tape 39, wherein the thickness is measured by the spacing created between the first and second insulated conductors 38 and 40. A typical spacing might be between four to twelve mils, such as about eight mils or about ten mils. By this arrangement, the twists of the first twisted pair 33 occupy a space within the dashed line 55, which is circumscribed by the helical twisting of the first and second insulated conductors 38 and 40. In this arrangement, the first through eighth insulated conductors 38, 40, 41, 43, 44, 46, 47 and 49 may contact each other if adjacent and also may contact the inner wall of the jacket 32.

[050] In Figure 5, the dielectric tape 39 is formed as a single unitary structure (e.g., the dielectric tape does not include multiple pieces attached together or layered). Figure 5A illustrates that the solid dielectric tape 39 of Figure 5 may be replaced with a dielectric tape 39A

having a hollow core filled with a gas, like air (with a dielectric constant of 1.0) or a foamed insulation material (with a dielectric constant approaching 1.0). By filling the hollow core with a gas or material with a lower dielectric constant than a material used to form said first dielectric tape 39 or 39A, the overall dielectric constant of the first dielectric tape 39A may be reduced. The hollow core may extend the entire length of the dielectric tape 39A, resulting in a “straw-like” structure. Alternatively, support structures may be formed at intervals along the length of the dielectric tape 39A to form closed-cell air pockets, each having a short length, such as 1/2 inch, one inch, two inches, etc. Alternatively, one or more support structures may be formed within the hollow core, which extend along the length of the dielectric tape 39A and connect between the lateral walls of the hollow core to resist crushing of the hollow core during the twisting of the first twisted pair 33A. Although the other embodiments of the dielectric tapes of the present invention are illustrated with solid cores, hollow cores, as described in connection with Figure 5A, may be employed in any or all of the other dielectric tapes. The first twisted pair 33A depicted in Figure 5A may be substituted into the place of the first twisted pair 33 depicted in Figure 4.

[051] The first through fourth twisted pairs 33, 34, 35 and 36 may be stranded together in the direction 57 (see the arrow in Figure 3) to form a stranded core. In one embodiment, the core strand direction 57 is opposite to the pair twist directions of the first through fourth twisted pairs 33, 34, 35 and 36. However, this is not a necessary feature, as in a preferred embodiment, the strand direction 57 is the same as the pair twist directions.

[052] In preferred embodiments, the strand length of the core strand is about five inches or less, more preferably about three inches or less. In a more preferred embodiment, the core strand length is purposefully varied, or modulates, from an average strand length along a length of the cable 31. Core strand modulation can assist in the reduction of alien crosstalk. For example, the core strand length could modulate between two inches and four inches along the length of the cable 31, with an average value of three inches.

[053] The first twist length w (See Figure 3) of the first twisted pair 33 is preferably set to a short length, such as between approximately 0.22 inches and approximately 0.38 inches. The second twist length x of the second twisted pair 34 is different from the first twist length w and is between approximately 0.22 inches and approximately 0.38 inches. For example, the first twist length w may be set to approximately 0.26 inches and the second twist length x may be set to approximately 0.33 inches.

[054] In one embodiment, the first twist length w purposefully modulates from a first average value, such as 0.26 inches. For example, the first twist length could purposefully vary between 0.24 and 0.28 inches along the length of the cable. Likewise, the second twist length could purposefully modulate from a second average value, such as 0.33 inches. For example, the second twist length could purposefully vary between 0.31 and 0.35 inches along the length of the cable.

[055] The third twisted pair 35 would have a third twist length y and the fourth twisted pair 36 would have a fourth twist length of z . In one embodiment, the third twist length y is different from the first, second and fourth twist lengths w , x and z , while the fourth twist length z is different from the first, second and third twist lengths w , x and y . Of course, the third and fourth twisted pairs 35 and 36 could employ a similar twist length modulation, as described in conjunction with the first and second twisted pairs 33 and 34.

[056] Figure 6 is a close-up cross sectional view of a twisted pair 60, having a dielectric tape 61 with an alternative shape, in accordance with a second embodiment of the present invention. The dielectric tape 61 has a width which extends approximately perpendicular to an extension length of the twisted pair 60 from a first edge 62 of the dielectric tape 61 to an opposing second edge 63 of the dielectric tape 61. The width, in the embodiment of Figure 6, is equal to or less than the diameter of the first insulated conductor 38. Less material is used to form the dielectric tape 61 in the embodiment of Figure 6. This presents advantages in reducing the amount of consumable material in the case of a fire, and in reducing the amount of smoke emitted from the cable 31 in the case of a fire. This structure may also reduce the weight and outer diameter of the cable and improve the flexibility of the cable.

[057] As seen in Figure 6, the dielectric tape 61 has a cross sectional shape in a direction perpendicular to an extension length of the twisted pair 60, which presents a first recessed portion 64 for seating the first insulated conductor 38 and a second recessed portion 65 for seating the second insulated conductor 40.

[058] The cross sectional shapes of the dielectric tapes 39 and 61 in Figures 5 and 6 are mirror symmetrical. However, it is not necessary that the shape be mirror symmetrical in order to achieve many of the advantages of the present invention. Further, the first and second recessed portions 64 and 65 of the dielectric tape 61 in Figure 6 are semi-circular in shape. However, it is not necessary that the first and second recessed portions 64 and 65 be semi-circular. In fact, the

recesses in the dielectric tape 39 of Figure 5 for receiving the first and second insulated conductors 38 and 40 are not semi-circular in shape. Also, the first and second recessed portions 64 and 65 may include serrations to create pockets of air adjacent to the seated portions of the first and second insulated conductors 38 and 40.

[059] Figure 7 is a cross sectional view of a twisted pair cable 66 employing the first twisted pair 60 of Figure 6. The twisted pair cable 66 also includes similarly configured second, third and fourth twisted pairs 67, 68 and 69. The twists of the first, second, third and fourth twisted pairs 60, 67, 68 and 69 occupy respective spaces within the dashed lines 55 (See Figure 6). In this arrangement, the first through eighth insulated conductors 38, 40, 41, 43, 44, 46, 47 and 49 may contact each other and also may contact the inner wall of the jacket 32.

[060] Figure 8 is a close-up cross sectional view of a twisted pair 70, having a dielectric tape 71 with an alternative shape, in accordance with a third embodiment of the present invention. The dielectric tape 71 has a width which extends approximately perpendicular to an extension length of the twisted pair 70 from a first edge 72 of the dielectric tape 71 to an opposing second edge 73 of the dielectric tape 71. The width, in the embodiment of Figure 8, is equal to or less than the diameter of the first insulated conductor 38.

[061] The embodiment of Figure 8 illustrates that the dielectric tape 71 need not have recessed portions 64 and 65 (as shown in Figures 5 and 6) to seat the insulated conductors 38 and 40. Rather, the dielectric tape 71 may be formed as a generally flat member. The dielectric tape 71 will remain between the first and second insulated conductors 38 and 40 due to the frictional forces created during the twisting operation, when the twisted pair 70 is formed.

[062] Figure 8A is a close-up cross sectional view of a twisted pair 70A, having a dielectric tape 71A with an alternative shape, in accordance with a fourth embodiment of the present invention. The dielectric tape 71A has a width which extends approximately perpendicular to an extension length of the twisted pair 70A from a first edge 72A of the dielectric tape 71A to an opposing second edge 73A of the dielectric tape 71A. The width, in the embodiment of Figure 8A, is equal to or slightly less than (e.g., two to four mils less than) the diameter of the first insulated conductor 38 plus the diameter of the second insulated conductor 40 plus a thickness of the dielectric tape 71A.

[063] The embodiment of Figure 8A illustrates that the dielectric tape 71A may be a generally flat member having a width which is approximately equal the diameter of the first

insulated conductor 38 plus the diameter of the second insulated conductor 40 plus a thickness of the dielectric tape 71A, such as about seventy-two mils plus or minus about three mils.

[064] Figure 8B is a cross sectional view of a twisted pair cable 76 employing the first twisted pair 70A of Figure 8A, in accordance with a preferred embodiment of the present invention. The twisted pair cable 76 also includes similarly configured second, third and fourth twisted pairs 77, 78 and 79. The twists of the first, second, third and fourth twisted pairs 70A, 77, 78 and 79 occupy respective spaces within the dashed lines 55 (See Figure 8A). In this arrangement, the first through eighth insulated conductors 38, 40, 41, 43, 44, 46, 47 and 49 may contact a plus-shaped separator 37A (sometimes referred to as an isolator, a flute or a crossweb) and also may contact inner ends of projections or fins 32A on the inner wall of the jacket 32. Figure 8B shows twelve projections 32A, however more or fewer projections may be included, with the goal being to hold the core of twisted pairs 70A, 77, 78 and 79 in the center of the cable 76 while creating air pockets around the perimeter of the core of twisted pairs.

[065] Figure 9 is a perspective view of a twisted pair cable 81, in accordance with a fifth embodiment of the present invention. Figure 10 is a cross sectional view of the cable 81 taken along line X--X in Figure 9. The cable 81 includes a jacket 82 formed around and surrounding first, second, third and fourth twisted pairs 83, 84, 85 and 86, respectively.

[066] The fifth embodiment of the invention, as illustrated in Figures 9 and 10, does not include a separator 37. However, pair separators (sometimes referred to as tapes, isolators, flutes or crosswebs) may optionally be included, if desired.

[067] As best seen in the cross sectional view of Figure 10, the first twisted pair 83 includes a first insulated conductor 88, a first dielectric tape 89, and a second insulated conductor 90. The first insulated conductor 88 is twisted with the second insulated conductor 90, in a helical fashion, with the first dielectric tape 89 residing between the first insulated conductor 88 and the second insulated conductor 90.

[068] The second twisted pair 84 includes a third insulated conductor 91, a second dielectric tape 92, and a fourth insulated conductor 93. The third insulated conductor 91 is twisted with the fourth insulated conductor 93, in a helical fashion, with the second dielectric tape 92 residing between the third insulated conductor 91 and the fourth insulated conductor 93.

[069] The third twisted pair 85 includes a fifth insulated conductor 94, a third dielectric tape 95, and a sixth insulated conductor 96. The fifth insulated conductor 94 is twisted with the sixth insulated conductor 96, in a helical fashion, with the third dielectric tape 95 residing between the fifth insulated conductor 94 and the sixth insulated conductor 96.

[070] The fourth twisted pair 86 includes a seventh insulated conductor 97, a fourth dielectric tape 98, and an eighth insulated conductor 99. The seventh insulated conductor 97 is twisted with the eighth insulated conductor 99, in a helical fashion, with the fourth dielectric tape 98 residing between the seventh insulated conductor 97 and the eighth insulated conductor 99.

[071] Figure 11 is a close-up view of the first twisted pair 83, which is similarly constructed to the second, third and fourth twisted pairs 84, 85 and 86. Like the first embodiment of Figures 3-5, each of the first through eighth insulated conductors 88, 90, 91, 93, 94, 96, 97 and 99 is formed by a conductor K surrounded by a layer of dielectric insulating material R. Also, the insulating material R may have a radial thickness of about seven mils or less, more preferably about five mils or less.

[072] As best seen in Figure 11, the first dielectric tape 89 has a first width which extends approximately perpendicular to an extension length of the first twisted pair 83 from a first edge 101 of the first dielectric tape 89 to a second edge 103 of the first dielectric tape 89. The first width is greater than a diameter of the first insulated conductor 88 plus a diameter of the second insulated conductor 90 plus a thickness of the first dielectric tape 89, wherein the thickness is measured by the spacing created between the first and second insulated conductors 88 and 90. A typical spacing might be between four to twelve mils, such as about eight mils or about ten mils. By this arrangement, the twists of the first twisted pair 83 occupy a space within the dashed line 105, which is circumscribed by the helical twisting of the first and second edges 101 and 103 of the first dielectric tape 89. In this arrangement, the first through eighth insulated conductors 88, 90, 91, 93, 94, 96, 97 and 99 do not contact each other and also do not contact the inner wall of the jacket 82. Rather, a small air pocket 107 is maintained around the outer perimeter of the dielectric insulating material R. Hence, the first insulated conductor 88 would be spaced from the inner wall of the jacket 82 by a first minimum distance, where the first minimum distance could be fixed in the range of one to twenty mils, such as two mils or four mils. Moreover, the first insulated conductor 88 would be spaced from any other insulated conductor of another twisted pair 84, 85 or 86 of the cable 81 by a second minimum distance. The second minimum distance would equal twice the first minimum distance, because the small air pocket

107 of the first twisted pair 83 would be added to the small air pocket 107 of the other twisted pair 84, 85 or 86.

[073] As in the first embodiment of Figures 3-5, the first through fourth twisted pairs 83, 84, 85 and 86 may be stranded together in the direction 109 (see the arrow in figure 9) to form a stranded core. In one embodiment, the core strand direction 109 is opposite to the pair twist directions of the first through fourth twisted pairs 83, 84, 85 and 86. However, this is not a necessary feature. The core strand length and pair twist lengths w, x, y and z may be tight, as described in conjunction with Figures 3-5, and may optionally be modulated.

[074] As best seen in the cross sectional view of Figure 11, the first dielectric tape 89 includes first and second recesses 111 and 113 to seat the first and second insulated conductors 88 and 90. The first and second recesses 111 and 113 may assist in properly positioning the three parts 88, 89 and 90 of the first twisted pair 83 during a manufacturing process, and may also assist in keeping the three parts 88, 89 and 90 of the first twisted pair 83 in place during use of the cable 81 (e.g., pulling of the cable through conduits or ductwork). However, many advantages of the invention may be achieved without the recesses 111 and 113, as will be seen in Figure 12.

[075] Figure 12 is a close-up cross sectional view of a twisted pair 120, having a dielectric tape 121 with an alternative shape, in accordance with a sixth embodiment of the present invention. The dielectric tape 121 has a width which extends approximately perpendicular to an extension length of the twisted pair 120 from a first edge 122 of the dielectric tape 121 to a second edge 123 of the dielectric tape 121. Like the embodiment of Figures 9-11, the width of the dielectric tape 121 is greater than the diameter of the first insulated conductor 88 plus the diameter of the second insulated conductor 90 plus a thickness of the first dielectric tape 121. The dielectric tape 121 may be formed as a generally flat member. The dielectric tape 121 will remain between the first and second insulated conductors 88 and 90 due to the frictional forces created during the twisting operation, when the twisted pair 120 is formed.

[076] Figure 13 is a close-up cross sectional view of a twisted pair 130, having a dielectric tape 131 with an alternative shape, in accordance with a seventh embodiment of the present invention. The dielectric tape 131 has a width which extends approximately perpendicular to an extension length of the twisted pair 130 from a first edge 132 of the dielectric tape 131 to a second edge 133 of the dielectric tape 131. The dielectric tape 131 has a cross sectional shape in a direction perpendicular to an extension length of the twisted pair 130, which

presents a first recessed portion 135 for seating the first insulated conductor 88 and a second recessed portion 136 for seating the second insulated conductor 90.

[077] The first edge 132 of the first dielectric tape 131 in Figure 13 will circumscribe an area 105 around the first twisted pair 130, which includes the small air gaps 107. However, the width of the first dielectric tape 131 is only slightly more than one-half the width of the dielectric tape 89 in the embodiment of Figures 9-11. Figure 14 illustrates a cable 140 with a jacket 141, wherein the first twisted pair 130 is stranded with three other similarly-configured twisted pairs, namely a second twisted pair 142, a third twisted pair 143 and a fourth twisted pair 144.

[078] Some of the advantages of the seventh embodiment of Figures 13 and 14 over the fifth embodiment of Figures 9-11 are that the material cost, and the weight of the cable 140 can be reduced. Yet, the seventh embodiment of Figures 13 and 14 will still create the small air gaps 107, primarily due to the tight twist lengths of the first through fourth twisted pairs 130, 142, 143 and 144.

[079] Figure 15 is a close-up cross sectional view of a twisted pair 150, having a dielectric tape 151 with an alternative shape, in accordance with a eighth embodiment of the present invention. The eighth embodiment is identical to the seventh embodiment of Figures 13 and 14, except that the dielectric tape 151 does not have recessed seats 135 and 136 to seat the first and second insulated conductors 88 and 90. Rather, the dielectric tape 151 has a substantially rectangular cross sectional shape. The dielectric tape 151 will remain between the first and second insulated conductors 88 and 90 due to the frictional forces created during the twisting operation, when the twisted pair 150 is formed.

[080] In cables of the background art, different twist lengths were applied to each of the four twisted pairs. The different twist lengths had the benefit of reducing crosstalk between adjacent pairs within the cable. However, employing different twist lengths also created drawbacks, such as delay skew (e.g., it takes more time for a signal to travel to the far end of the cable on a relatively tighter twisted pair, as compared to a relatively longer twisted pair in the same cable). Differing twist lengths can also cause relative differences between the twisted pairs in such performance characteristics as attenuation and impedance.

[081] In the background art, the insulation layers R were varied in thickness and/or material composition to compensate for the differences. For example, the insulation layers R of

the insulated conductors 91 and 93 in the tighter twisted pair 84 (in Figure 9) could be formed of a material with a different dielectric constant than the insulation layers R of the insulated conductors 94 and 96 in the longer twisted pair 85 (in Figure 9). Also, air could be introduced into the insulation layers R to foam the insulation layers R. The foaming could be set at different levels for one or more of the twisted pairs, depending upon their twist length.

[082] Such measures of the background art helped to offset the different performance characteristics induced by the different twist lengths of the twisted pairs. However, there was an added cost in that the insulated conductors used in different twisted pairs of the same cable had to be manufactured differently. This created a need for inventorying different types of insulated conductors and added more complexity in the manufacturing process.

[083] In accordance with one embodiment of the present invention, the insulated conductors 38, 40, 41, 43, 44, 46, 47 and 49 of each of the twisted pairs 33, 34, 35 and 36 in the cable 31 may be made structurally identical (noting that certain non-structural features, like colors, stripe patterns or printed indicia may be employed to merely identify the insulated conductors from each other). In this embodiment of the present invention, the dielectric tape structure can be used to mitigate the performance differences, which arise when different twist lengths are employed in the twisted pairs. Moreover, the insulated conductors 38, 40, 41, 43, 44, 46, 47 and 49 may be made structurally identical and also be identical in appearance. In this embodiment, the color of, or indicia on, the first through fourth dielectric tapes 39, 42, 45 and 48 could be used to distinguish between the first through fourth twisted pairs 33, 34, 35 and 36 of the cable 31, when the cable 31 is terminated and a connector is attached thereto.

[084] For example, the dielectric tape of one twisted pair of a given cable may be different in shape, size or material content as compared to the dielectric tape of another twisted pair in the same cable. In Figure 4, the first dielectric tape 39 of the first twisted pair 33 has a first thickness, which sets a spacing distance between the first insulated conductor 38 and the second insulated conductor 40. In the third twisted pair 35, the third dielectric tape 45 has a second thickness, which sets a spacing distance between the fifth insulated conductor 44 and the sixth insulated conductor 46. The second thickness is different from the first thickness, which also means that the shape of the first dielectric tape 39 is different than the shape of the third dielectric tape 45.

[085] In one embodiment, the difference between the second thickness and the first thickness is at least 1 mil. For example, the first dielectric tape 39 could have a thickness of about 10 mils, whereas the third dielectric tape 45 could have a thickness of about 8 mils. Such a change in thickness and shape will affect the respective performance characteristics of the first twisted pair 33 and the third twisted pair 35, such as their respective attenuation, impedance, delay skew, etc.

[086] Also in Figure 4, the first dielectric tape 39 of the first twisted pair 33 has a first width, which extends approximately perpendicular to an extension length of said cable 31 from its first edge 51 to its second edge 53 (See Figure 5). In the fourth twisted pair 36, the fourth dielectric tape 48 has a second width, which extends approximately perpendicular to the extension length of said cable 31 from its corresponding first edge 51 to its corresponding second edge 53. The second width is different from the first width. For example, the second width may be several mils shorter than the first width, such as about 2 to 12 mils shorter, e.g., about 5 mils shorter. Again, the respective differences in width will serve to create differences in performance characteristics, which can be adjusted and used to offset for the performance differences created by the different twist lengths.

[087] Also in Figure 4, the first dielectric tape 39 of the first twisted pair 33 is formed of a first material having a first dielectric constant. In the second twisted pair 34, the second dielectric tape 42 is formed of a second material having a second dielectric constant (as illustrated by the different thicknesses in the cross hatching). The second dielectric constant is different from the first dielectric constant. For example, the second dielectric constant could differ from the first dielectric constant by about 0.1 to about 0.8, e.g., the first dielectric constant might be 1.2, whereas the second dielectric constant is 1.4, thus illustrating a difference of 0.2 in dielectric constant between the two materials. Again, the respective differences in material will serve to create differences in performance characteristics, which can be adjusted and used to offset for the performance differences created by the different twist lengths. Of course, the differences between the dielectric tapes can also be employed as a supplemental measure in conjunction with differences in insulation layers on the insulated conductors to provide an additional ability to compensate for performance differences between the twisted pairs.

[088] The cables 31, 66, 81 and 140 of the present invention may be manufactured using standard twisting equipment, such as a double twist twinning machine, known in the art of

twisted pair cable making. An additional spool would be added to feed the dielectric tape into the twisting machine between the insulated conductors of the twisted pair.

[089] Although, the cables illustrated in the drawing figures have included four twisted pairs, it should be appreciated that the present invention is not limited to cables having only four twisted pairs. Cables having other numbers of twisted pairs, such as one twisted pair, two twisted pairs or even twenty-five twisted pairs, could benefit from the structures disclosed in the present invention. Further, although the drawing figures have illustrated that each of the twisted pairs within the cable have a dielectric tape, it would be possible for less than all of the twisted pairs to have the dielectric tape. For example, the first through third twisted pairs could include a dielectric tape, while the fourth twisted pair could be formed without a dielectric tape. Further, although the drawing figures have illustrated an unshielded cable, it is within the scope of the appended claims that the cable could include a shielding layer and/or a core wrap between the core of twisted pairs and the inner wall of the outermost jacket. Further, although some drawing figures have illustrated a jacket having a smooth inner wall, it is within the scope of the present invention that in all embodiments the inner wall of the jacket could include fins or projections (as illustrated in Figure 8B) for creating air pockets around the perimeter of the core of twisted pairs. Further, all embodiments of the present invention may include a separator (e.g., tape, isolator, flute, crossweb).

**THE EMBODIMENTS OF THE INVENTION IN WHICH AN EXCLUSIVE
PROPERTY OR PRIVILEGE IS CLAIMED ARE DEFINED AS FOLLOWS:**

1. A cable comprising:
 - a first insulated conductor, a first dielectric tape, and a second insulated conductor, wherein said first insulated conductor is twisted with said second insulated conductor with said first dielectric tape residing between said first insulated conductor and said second insulated conductor to form a first twisted pair; and
 - a jacket formed around said first twisted pair, wherein
 - said first dielectric tape formed as a single unitary structure, and said first dielectric tape has a first width which extends approximately perpendicular to an extension length of said first twisted pair from a first edge of said first dielectric tape to a second edge of said first dielectric tape, and said first width is equal to or less than a diameter of said first insulated conductor.

2. The cable according to claim 1, further comprising:
 - a third insulated conductor, a second dielectric tape, and a fourth insulated conductor, wherein said third insulated conductor is twisted with said fourth insulated conductor with said second dielectric tape residing between said third insulated conductor and said fourth insulated conductor to form a second twisted pair, wherein

said first twisted pair is stranded with said second twisted pair to form a stranded core.

3. The cable according to claim 2, further comprising:
a separator within said jacket wherein said separator resides between said first twisted pair and said second twisted pair.

4. The cable according to claim 1, further comprising:
a third insulated conductor, a second dielectric tape, and a fourth insulated conductor, wherein said third insulated conductor is twisted with said fourth insulated conductor with said second dielectric tape residing between said third insulated conductor and said fourth insulated conductor to form a second twisted pair, wherein said second dielectric tape has a second width which extends approximately perpendicular to an extension length of said second twisted pair from a first edge of said second dielectric tape to a second edge of said second dielectric tape, and wherein said second width is equal to or less than a diameter of said third insulated conductor plus a diameter of said fourth insulated conductor plus a thickness of said second dielectric tape.

5. A cable comprising:
a first insulated conductor, a first dielectric tape, and a second insulated conductor, wherein said first insulated conductor is twisted

with said second insulated conductor with said first dielectric tape residing between said first insulated conductor and said second insulated conductor to form a first twisted pair; and

a jacket formed around said first twisted pair, wherein said first insulated conductor includes a first conductor of twenty three gauge, surrounded by a layer of first dielectric insulating material having a radial thickness of 7 mils or less.

6. The cable according to claim 5, wherein said radial thickness of said layer of first dielectric insulating material is about 5 mils or less and wherein said second insulated conductor includes a second conductor surrounded by a layer of second dielectric insulating material having a radial thickness of about 5 mils or less.

7. The cable according to claim 5, further comprising:

a third insulated conductor, a second dielectric tape, and a fourth insulated conductor, wherein said third insulated conductor is twisted with said fourth insulated conductor with said second dielectric tape residing between said third insulated conductor and said fourth insulated conductor to form a second twisted pair, wherein said first twisted pair is stranded with said second twisted pair to form a stranded core.

8. The cable according to claim 7, further comprising:

a separator within said jacket wherein said separator resides between said first twisted pair and said second twisted pair.

9. The cable according to claim 8, further comprising:

a third twisted pair and a fourth twisted pair within said jacket, wherein said separator resides between and separates said first twisted pair and said fourth twisted pairs from said second twisted pair and said third twisted pair.

10. The cable according to claim 5, wherein said first dielectric tape has a first width which extends approximately perpendicular to an extension length of said first twisted pair from a first edge of said first dielectric tape to a second edge of said first dielectric tape, and wherein said first width is greater than a diameter of said first insulated conductor plus a diameter of said second insulated conductor plus a thickness of said first dielectric tape.

11. The cable according to claim 10, further comprising:

a third insulated conductor, a second dielectric tape, and a fourth insulated conductor, wherein said third insulated conductor is twisted with said fourth insulated conductor with said second dielectric tape residing between said third insulated conductor and said fourth insulated conductor to form a second twisted pair, wherein said second dielectric tape has a second width which extends

approximately perpendicular to an extension length of said second twisted pair from a first edge of said second dielectric tape to a second edge of said second dielectric tape, and wherein said second width is greater than a diameter of said third insulated conductor plus a diameter of said fourth insulated conductor plus a thickness of said second dielectric tape.

12. The cable according to claim 5, wherein said first dielectric tape has a first width which extends approximately perpendicular to an extension length of said first twisted pair from a first edge of said first dielectric tape to a second edge of said first dielectric tape, and wherein said first width is equal to or less than a diameter of said first insulated conductor plus a diameter of said second insulated conductor plus a thickness of said first dielectric tape.

13. A cable comprising:

a first insulated conductor, a first dielectric tape, and a second insulated conductor, wherein said first insulated conductor is twisted with said second insulated conductor with said first dielectric tape residing between said first insulated conductor and said second insulated conductor to form a first twisted pair; and

a jacket formed around said first twisted pair, wherein said first dielectric tape has a cross sectional shape in a direction perpendicular to an extension length of said first twisted pair, which presents a first

recessed portion for seating said first insulated conductor and a second recessed portion for seating said second insulated conductor, wherein a first edge of said first dielectric tape circumscribes a helical path as said first insulated conductor is twisted with said second insulated conductor, and the helical path extends beyond said first and second insulated conductors, such that the first insulated conductor does not contact an inner wall of said jacket and is distanced from said inner wall of said jacket by a first minimum distance.

14. The cable according to claim 13, wherein said first dielectric tape has a first width which extends approximately perpendicular to an extension length of said first twisted pair from said first edge of said first dielectric tape to a second edge of said first dielectric tape, and wherein said first width is greater than a diameter of said first insulated conductor plus a diameter of said second insulated conductor plus a thickness of said first dielectric tape.

15. A cable comprising:

a first insulated conductor, a first dielectric tape, and a second insulated conductor, wherein said first insulated conductor is twisted with said second insulated conductor with said first dielectric tape residing between said first insulated conductor and said second insulated conductor to form a first twisted pair;

a third insulated conductor, a second dielectric tape, and a fourth insulated conductor, wherein said third insulated conductor is twisted with said fourth insulated conductor with said second dielectric tape residing between said third insulated conductor and said fourth insulated conductor to form a second twisted pair; and

a jacket formed around said first and second twisted pairs, wherein said first dielectric tape is different in shape, size or material content as compared to said second dielectric tape.

16. The cable according to claim 15, wherein said first dielectric tape has a first thickness which sets a spacing between said first insulated conductor and said second insulated conductor, wherein said second dielectric tape has a second thickness which sets a spacing between said third insulated conductor and said fourth insulated conductor, and wherein said second thickness is different from said first thickness.

17. The cable according to claim 16, wherein said second thickness differs from said first thickness by at least 1 mil.

18. The cable according to claim 16, wherein said first thickness is approximately 8 mils and said second thickness is approximately 10 mils.

19. The cable according to claim 15, wherein said first dielectric tape has a first width which extends approximately perpendicular to an extension length of said first twisted pair from a first edge of said first dielectric tape to a second edge of said first dielectric tape, wherein said second dielectric tape has a second width which extends approximately perpendicular to the extension length of said second twisted pair from a first edge of said second dielectric tape to a second edge of said second dielectric tape, and wherein said second width is different from said first width.

20. The cable according to claim 15, wherein said first dielectric tape is formed of a first material, wherein said second dielectric tape is formed of a second material; and wherein said second material has a dielectric constant which is different from said first dielectric constant.

21. A cable comprising:

a first insulated conductor, a first dielectric tape, and a second insulated conductor, wherein said first insulated conductor is twisted with said second insulated conductor with said first dielectric tape residing between said first insulated conductor and said second insulated conductor to form a first twisted pair;

a third insulated conductor, a second dielectric tape, and a fourth insulated conductor, wherein said third insulated conductor is

twisted with said fourth insulated conductor with said second dielectric tape residing between said third insulated conductor and said fourth insulated conductor to form a second twisted pair; and

a jacket formed around said first and second twisted pairs, wherein said first, second, third and fourth insulated conductors are identical in appearance, and said first dielectric tape is different in appearance from said second dielectric tape.

22. The cable according to claim 21, wherein said second dielectric tape has a different shape, color or indicia, as compared to said first dielectric tape.

23. A cable comprising:

a first insulated conductor, a first dielectric tape formed as a single unitary structure which does not include multiple pieces attached together or layered, and a second insulated conductor, wherein said first insulated conductor is twisted with said second insulated conductor with said first dielectric tape residing between said first insulated conductor and said second insulated conductor to form a first twisted pair; and

a jacket formed around said first twisted pair, wherein said first dielectric tape has a hollow core possessing a gas or material with a lower dielectric constant than a material used to form said first dielectric tape.

24. The cable according to claim 23, wherein said hollow core is partitioned into closed-cell pockets along a length of said first dielectric tape, and wherein said closed-cell pockets are filled with air.

25. The cable according to claim 23, wherein said first dielectric tape has a first width which extends approximately perpendicular to an extension length of said first twisted pair from a first edge of said first dielectric tape to a second edge of said first dielectric tape, and wherein said first width is equal to or less than a diameter of said first insulated conductor plus a diameter of said second insulated conductor plus a thickness of said first dielectric tape.

26. The cable according to claim 25, wherein said first width is equal to or less than the diameter of said first insulated conductor.

27. The cable according to claim 25, further comprising:

a third insulated conductor, a second dielectric tape, and a fourth insulated conductor, wherein said third insulated conductor is twisted with said fourth insulated conductor with said second dielectric tape residing between said third insulated conductor and said fourth insulated conductor to form a second twisted pair, wherein said second dielectric tape has a second width which extends approximately perpendicular to an extension length of said second

twisted pair from a first edge of said second dielectric tape to a second edge of said second dielectric tape, and wherein said second width is equal to or less than a diameter of said third insulated conductor plus a diameter of said fourth insulated conductor plus a thickness of said second dielectric tape.

28. The cable according to claim 27, wherein said first width is equal to or less than the diameter of said first insulated conductor and wherein said second width is equal to or less than the diameter of said third insulated conductor.

29. The cable according to claim 27, wherein a first twist length of said first twisted pair is between approximately 0.22 inches and approximately 0.38 inches, and wherein a second twist length of said second twisted pair is different from said first twist length and is between approximately 0.22 inches and approximately 0.38 inches, wherein the first twist length purposefully modulates from a first average value.

30. The cable according to claim 29, wherein the second twist length purposefully modulates from a second average value.

31. The cable according to claim 29, wherein said first twisted pair is stranded with said second twisted pair to form a stranded core, said

stranded core has a strand length of about 3 inches or less, and said stranded core has a strand length that modulates along a length of said cable.

32. The cable according to claim 25, wherein said hollow core is partitioned into closed-cell pockets along a length of said first dielectric tape, and wherein said closed-cell pockets are filled with air.

33. A cable comprising:

a first insulated conductor, a first dielectric tape formed as a single unitary structure which does not include multiple pieces attached together or layered, and a second insulated conductor, wherein said first insulated conductor is twisted with said second insulated conductor with said first dielectric tape residing between said first insulated conductor and said second insulated conductor to form a first twisted pair;

a third insulated conductor, a second dielectric tape, and a fourth insulated conductor, wherein said third insulated conductor is twisted with said fourth insulated conductor with said second dielectric tape residing between said third insulated conductor and said fourth insulated conductor to form a second twisted pair; and

a jacket formed around said first and second twisted pairs,

wherein said first dielectric tape has a first width which extends approximately perpendicular to an extension length of said first

twisted pair from a first edge of said first dielectric tape to a second edge of said first dielectric tape, and wherein said first width is equal to or less than a diameter of said first insulated conductor plus a diameter of said second insulated conductor plus a thickness of said first dielectric tape; and

wherein said first dielectric tape has a hollow core possessing a gas or material with a lower dielectric constant than a material used to form said first dielectric tape.

34. The cable according to claim 33, wherein said first insulated conductor includes a first conductor surrounded by a layer of first dielectric insulating material having a radial thickness of about 7 mils or less;

wherein said first dielectric tape has a cross sectional shape in a direction perpendicular to the extension length of said first twisted pair, which presents a first recessed portion for seating said first insulated conductor and a second recessed portion for seating said second insulated conductor;

wherein said first dielectric tape is different in shape, size or material content as compared to said second dielectric tape; and

wherein said first, second, third and fourth insulated conductors are identical in appearance, and said first dielectric tape is different in appearance from said second dielectric tape.

Application No. 2,719,015
Canadian National Entry of PCT/US2009/037709

Attorney Docket No. 28679-4
Page 32

35. The cable according to claim 33, wherein said first width is equal to or less than the diameter of said first insulated conductor.

1/10

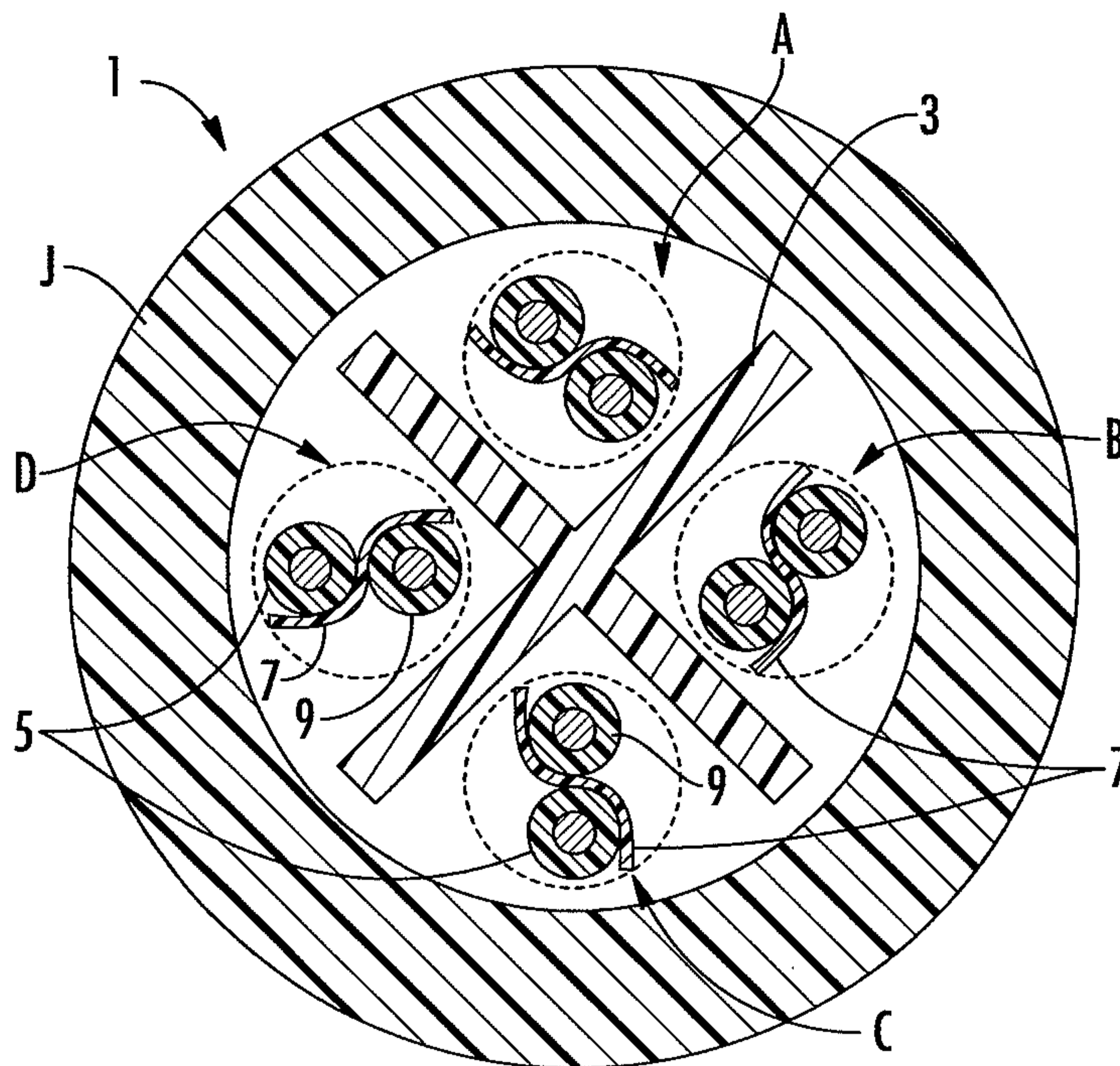

FIG. 1
(PRIOR ART)

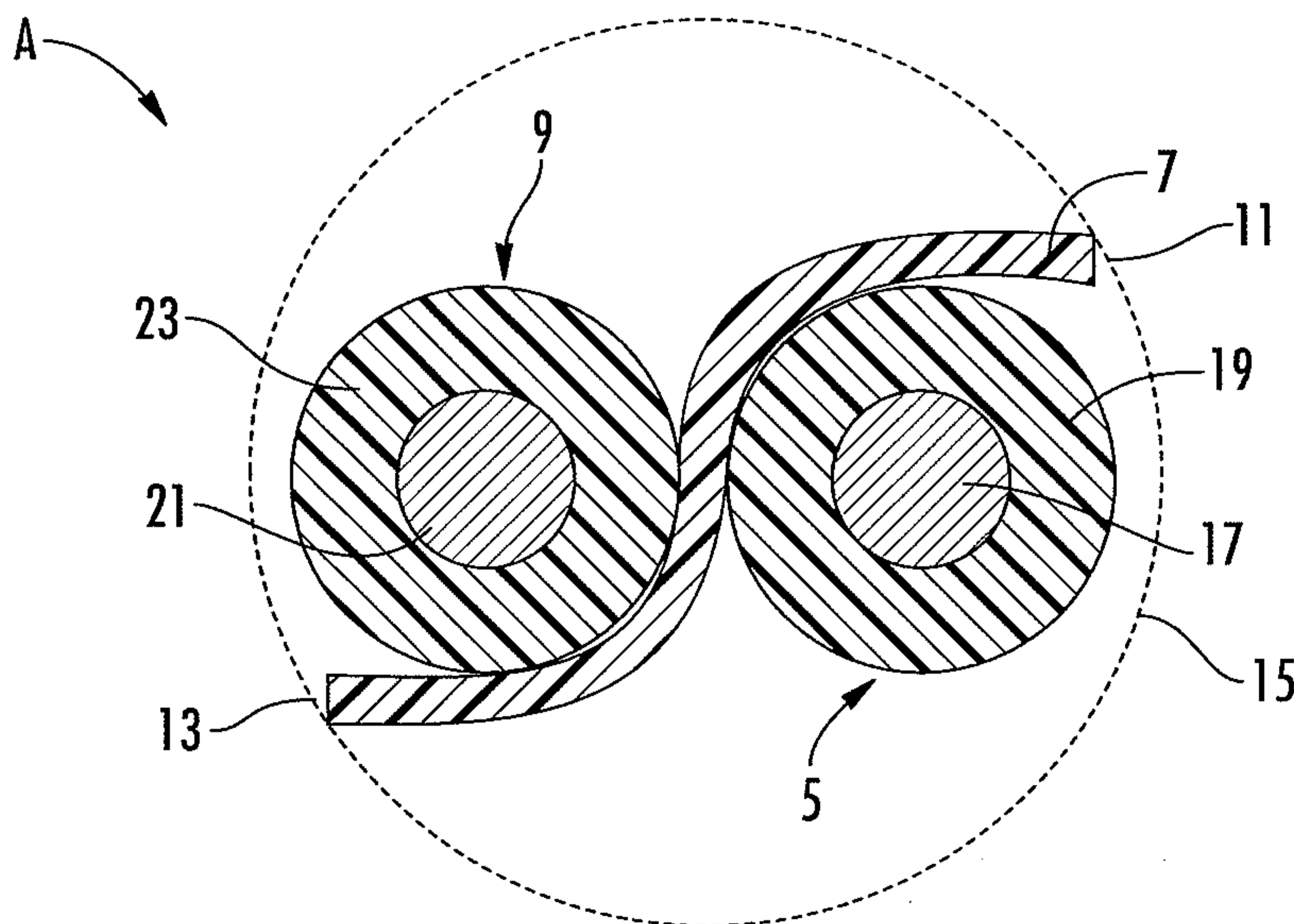

FIG. 2
(PRIOR ART)

2/10

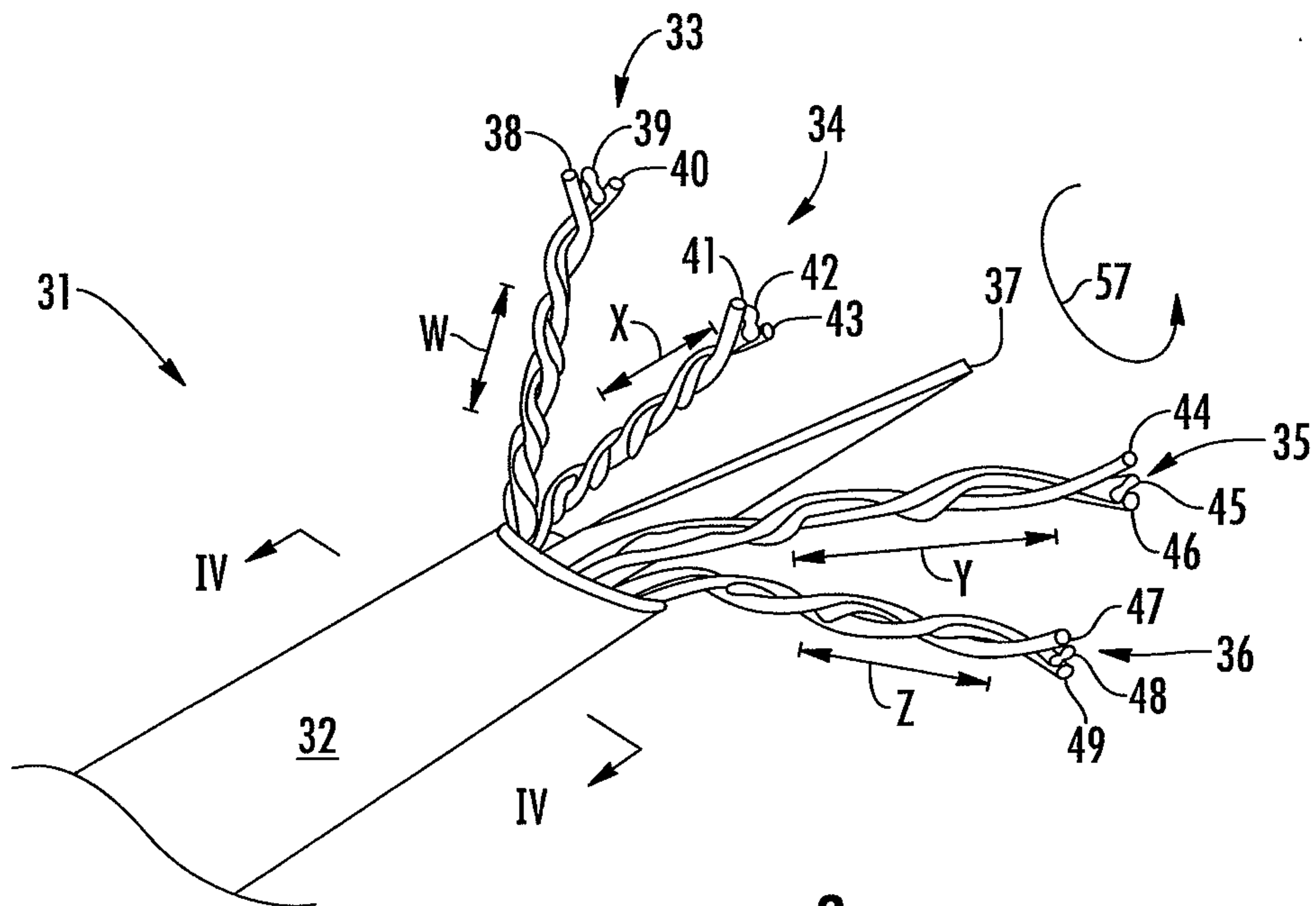

FIG. 3

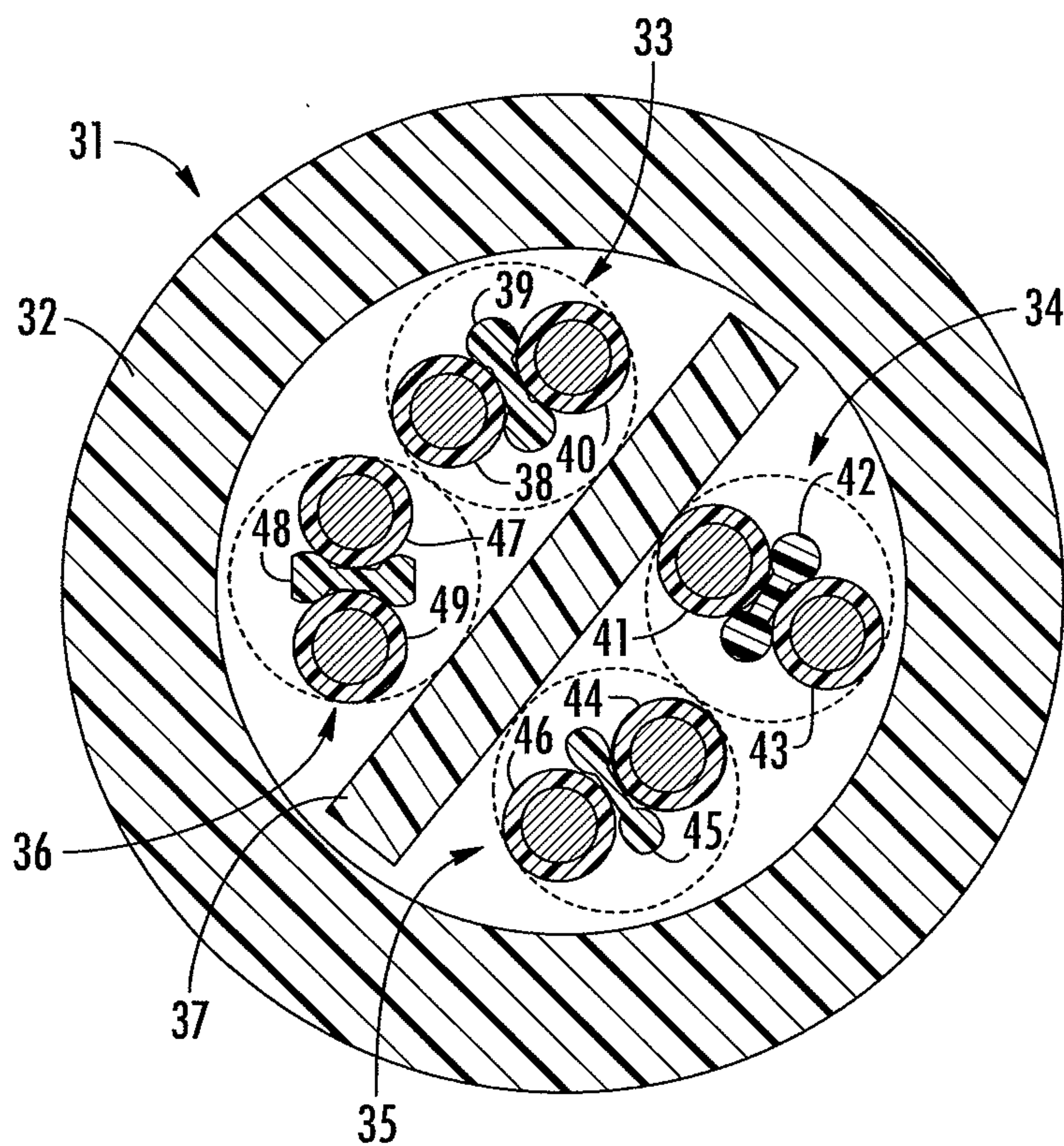

FIG. 4

3/10

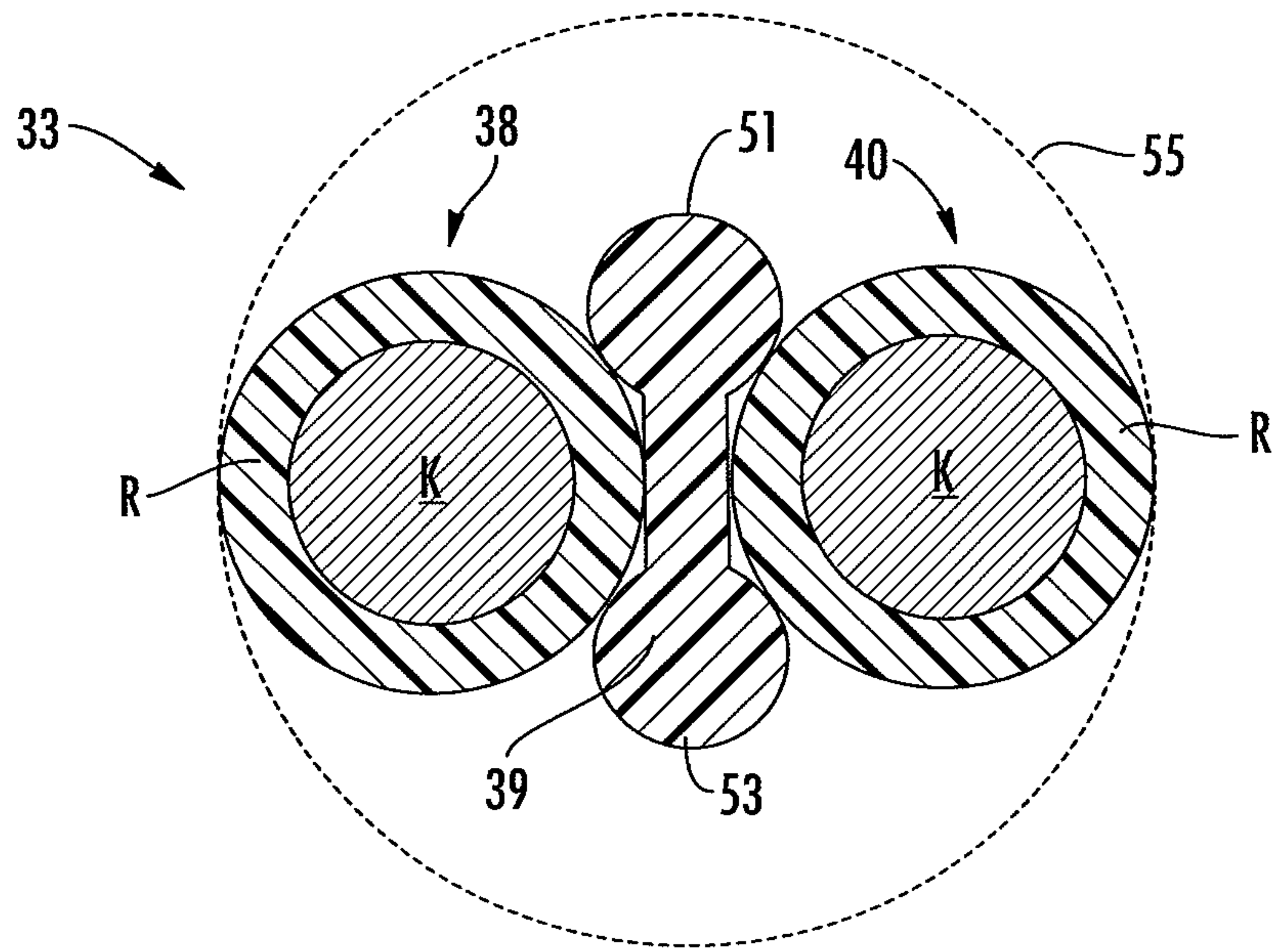

FIG. 5

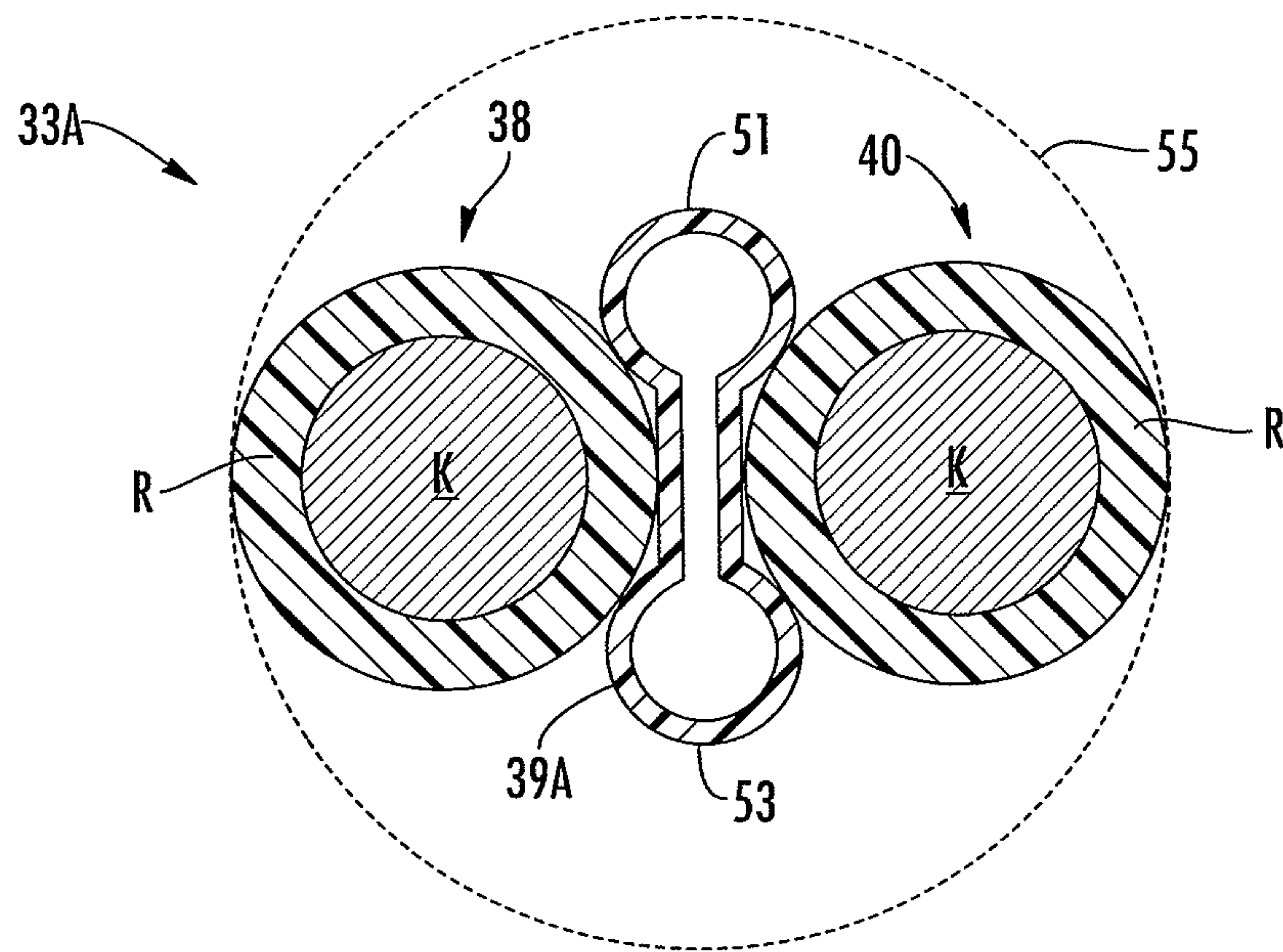

FIG. 5A

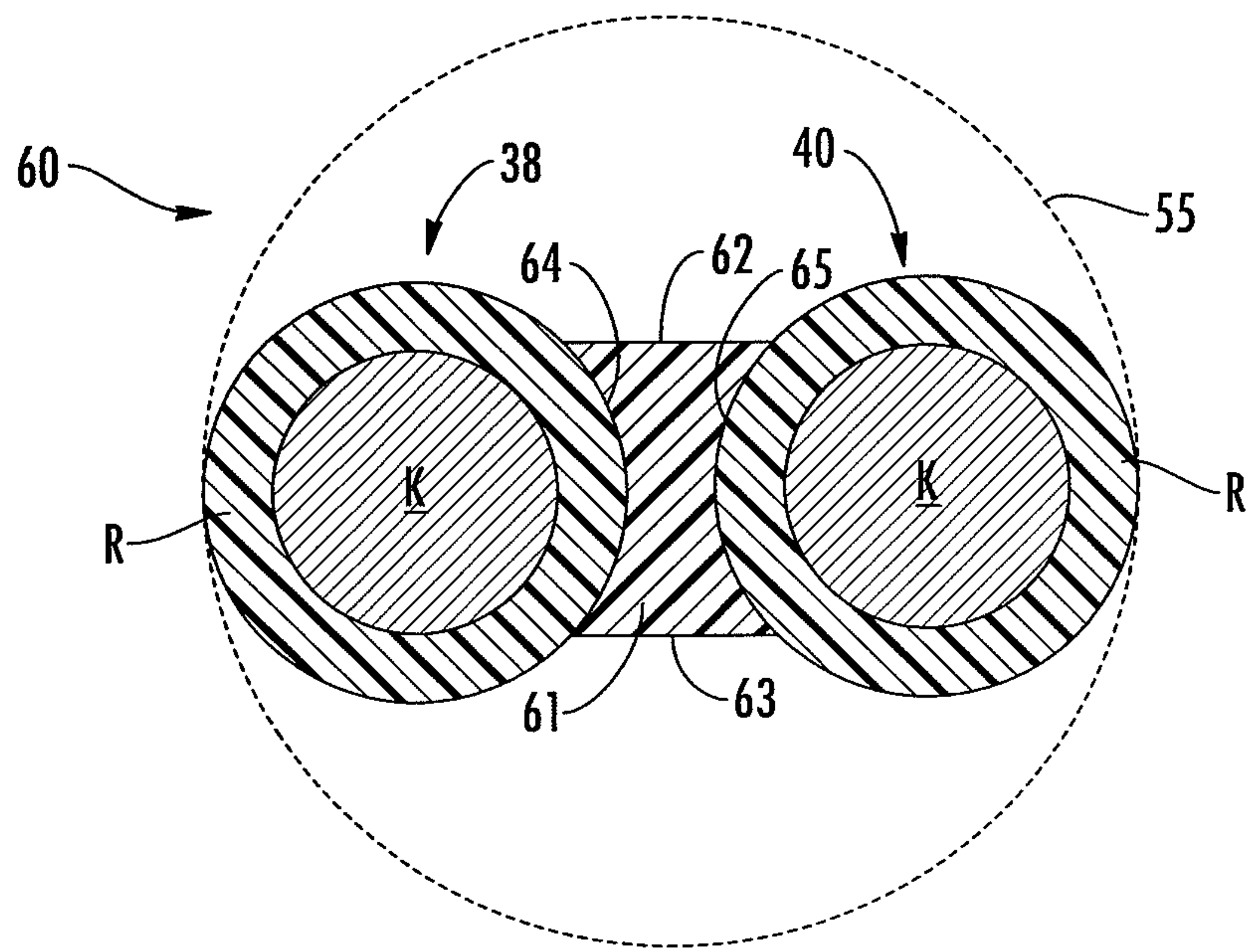

FIG. 6

5/10

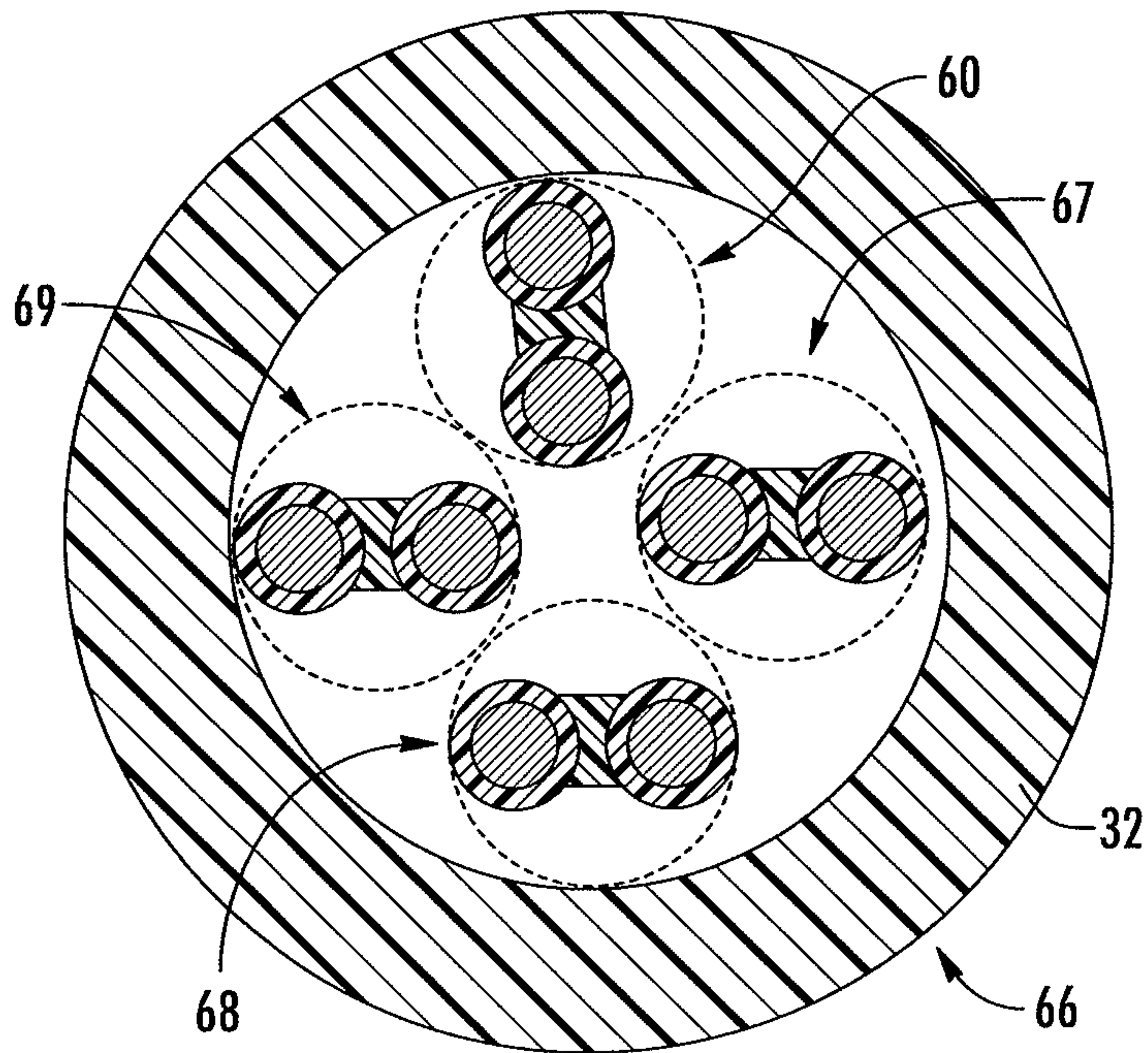

FIG. 7

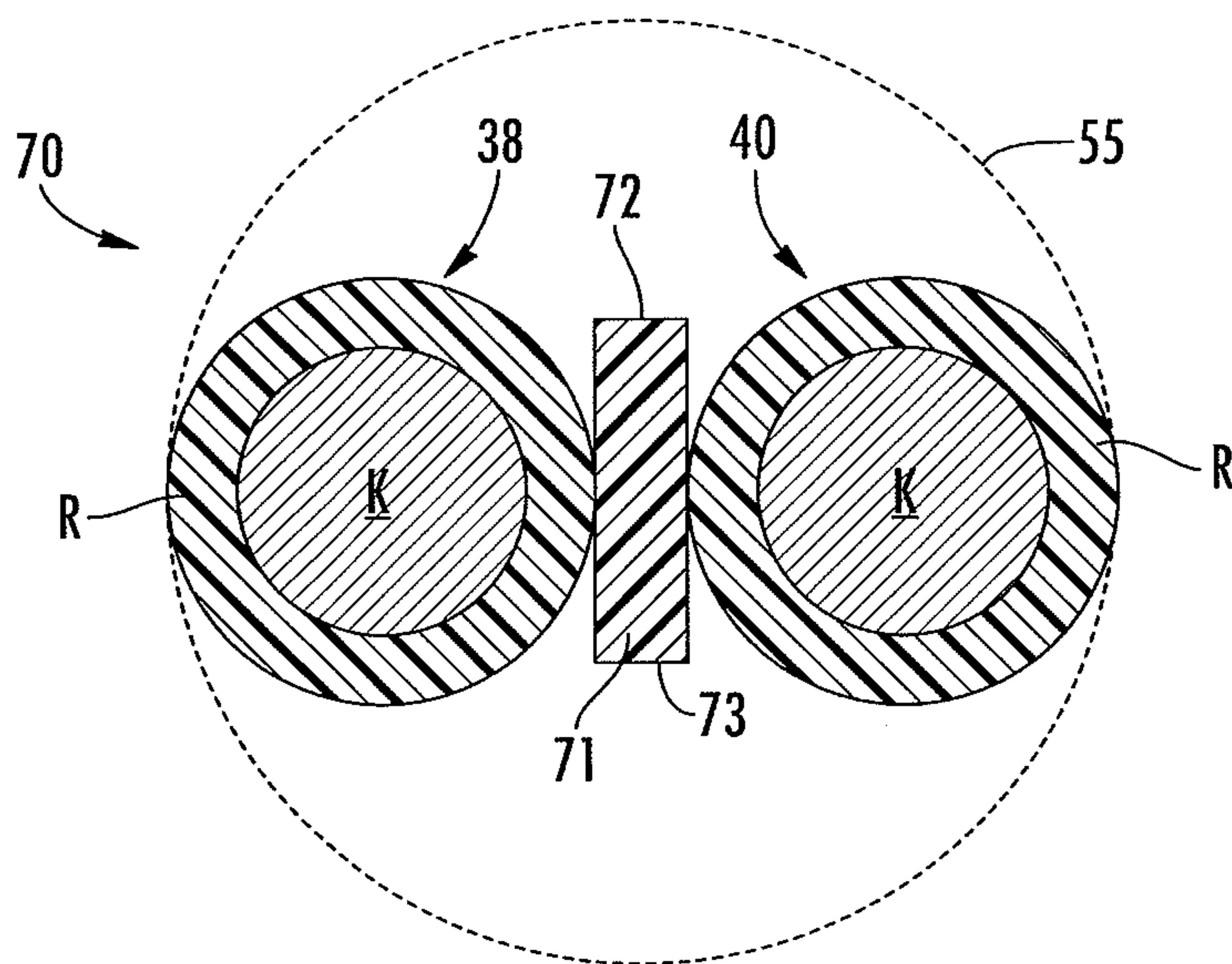

FIG. 8

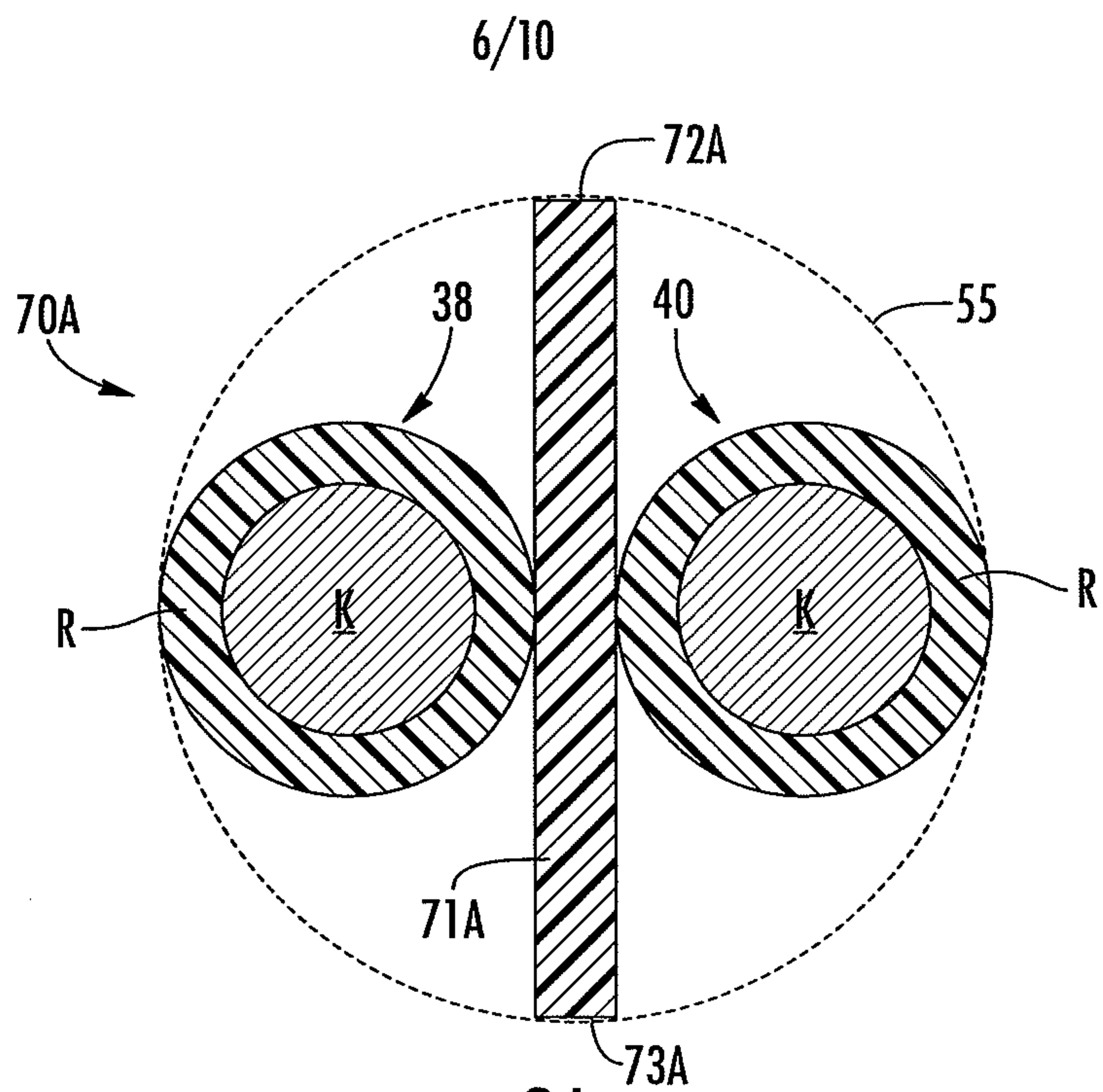

FIG. 8A

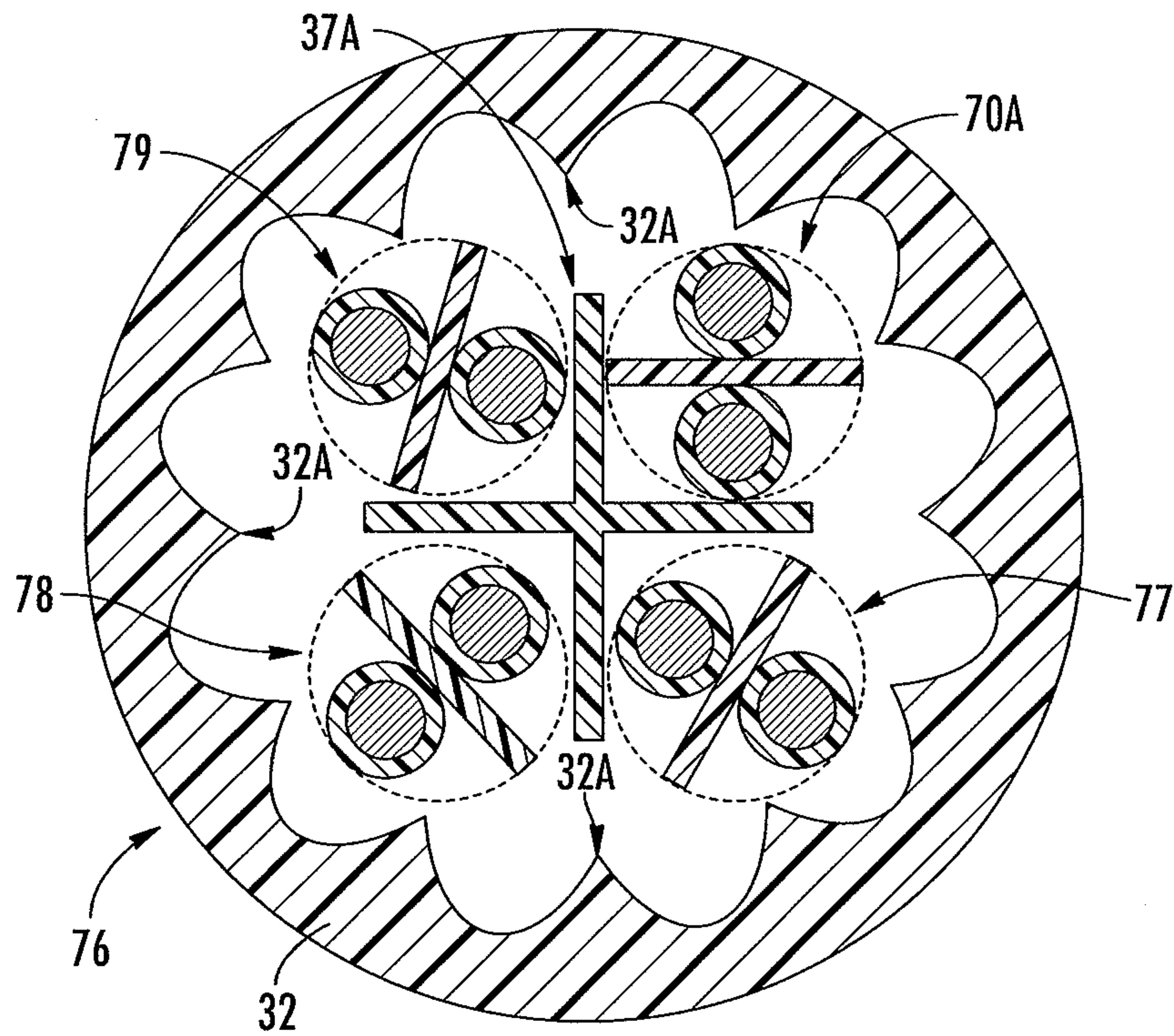

FIG. 8B

7/10

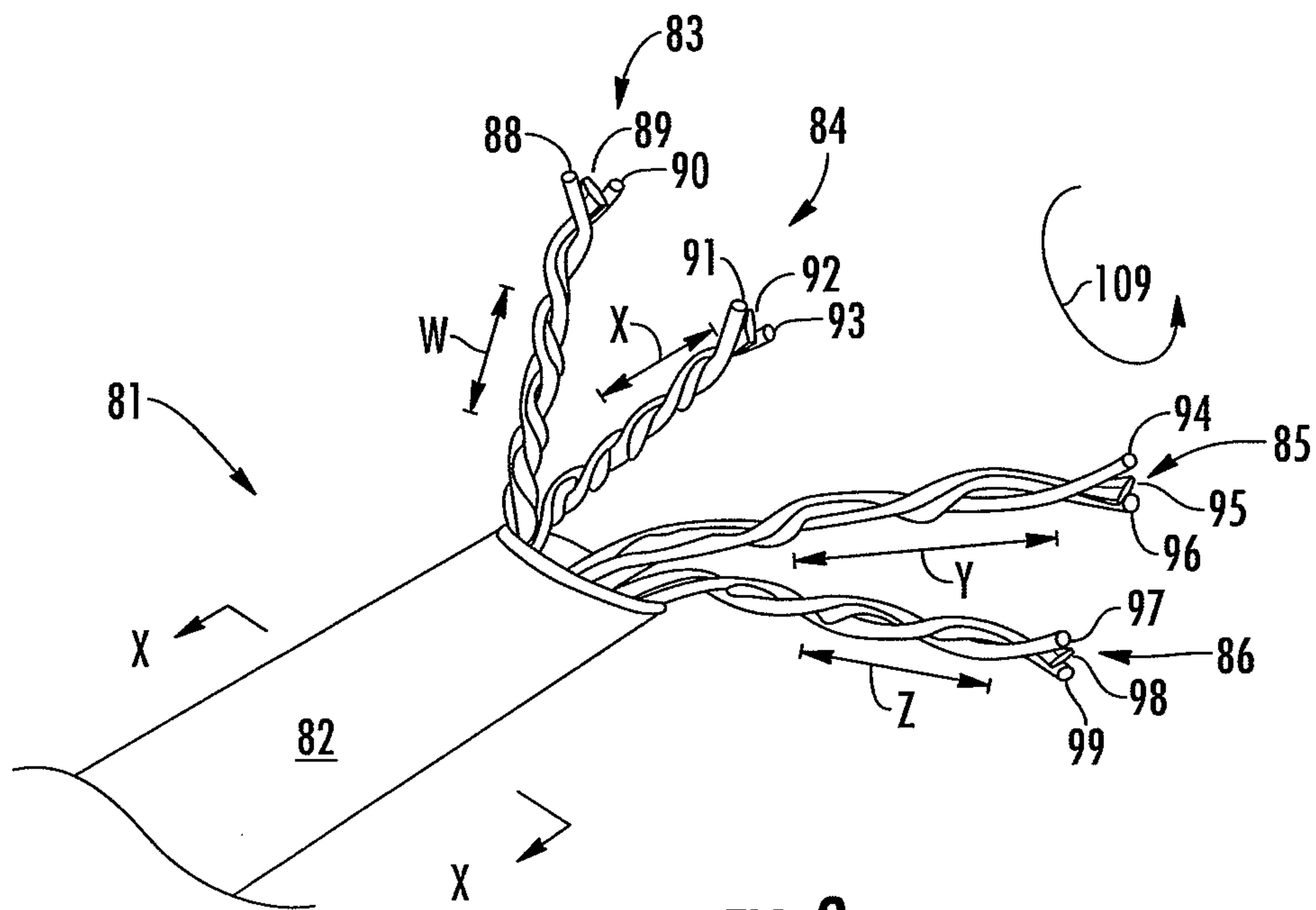

FIG. 9

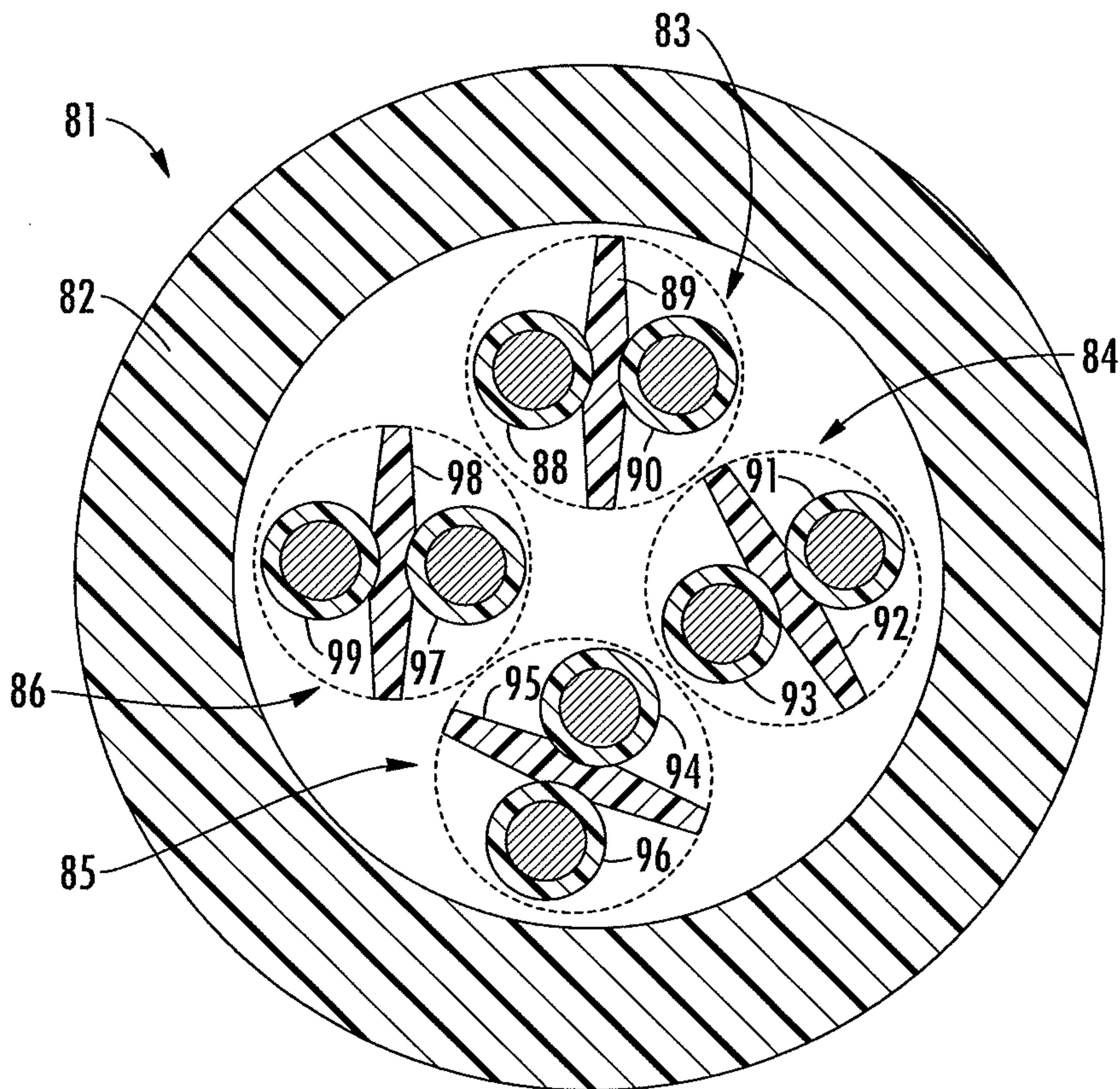

FIG. 10

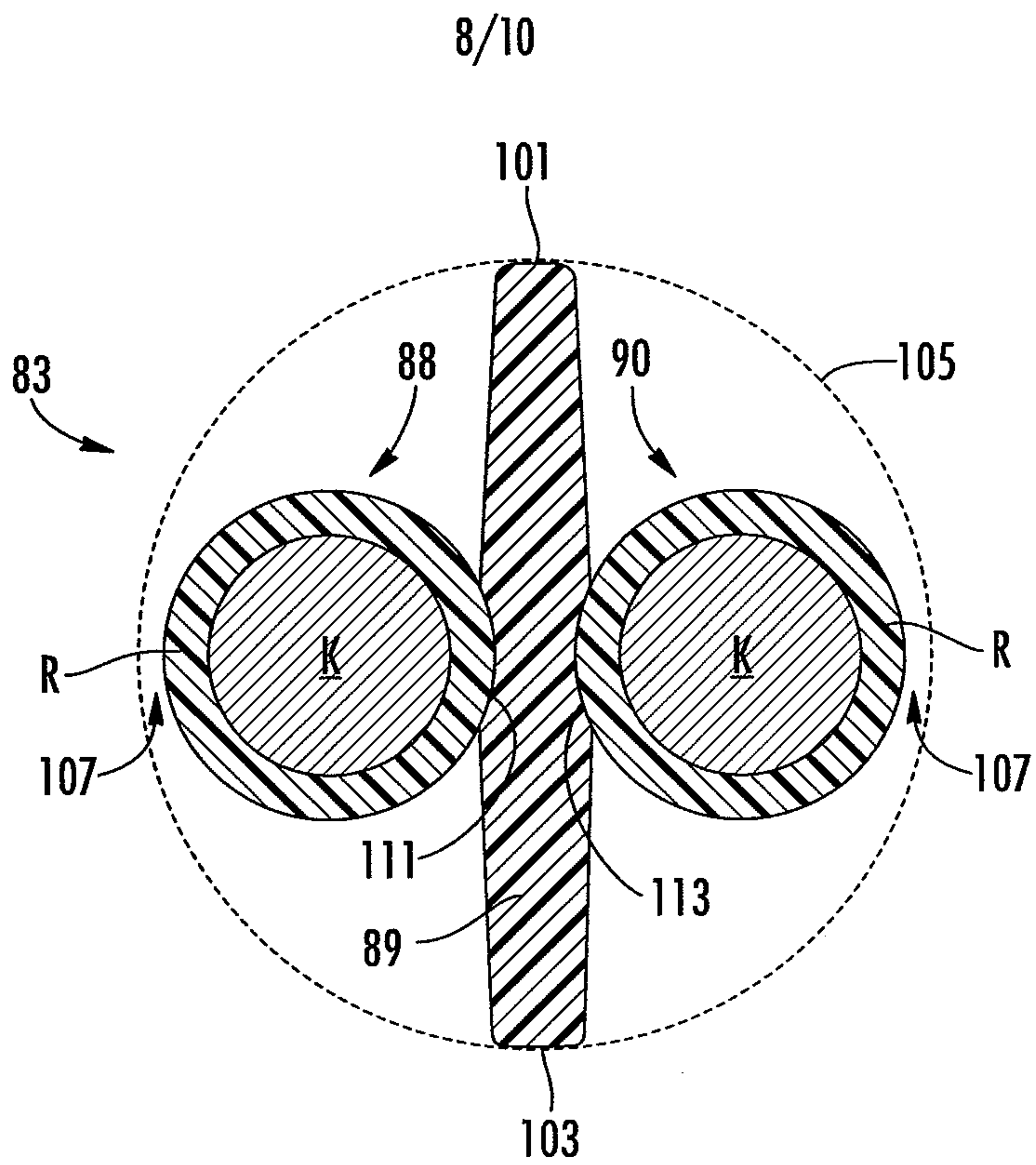

FIG. 11

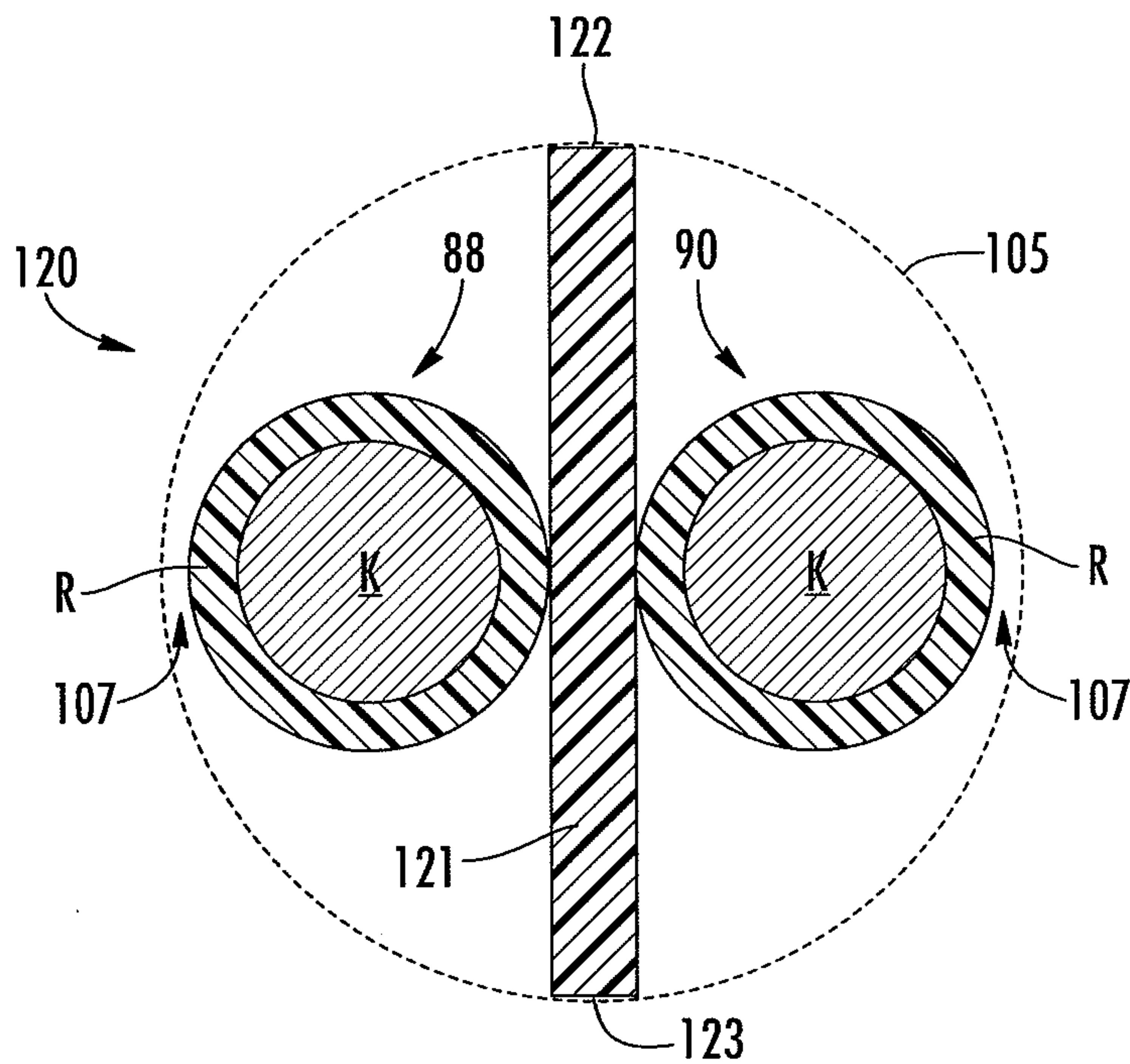

FIG. 12

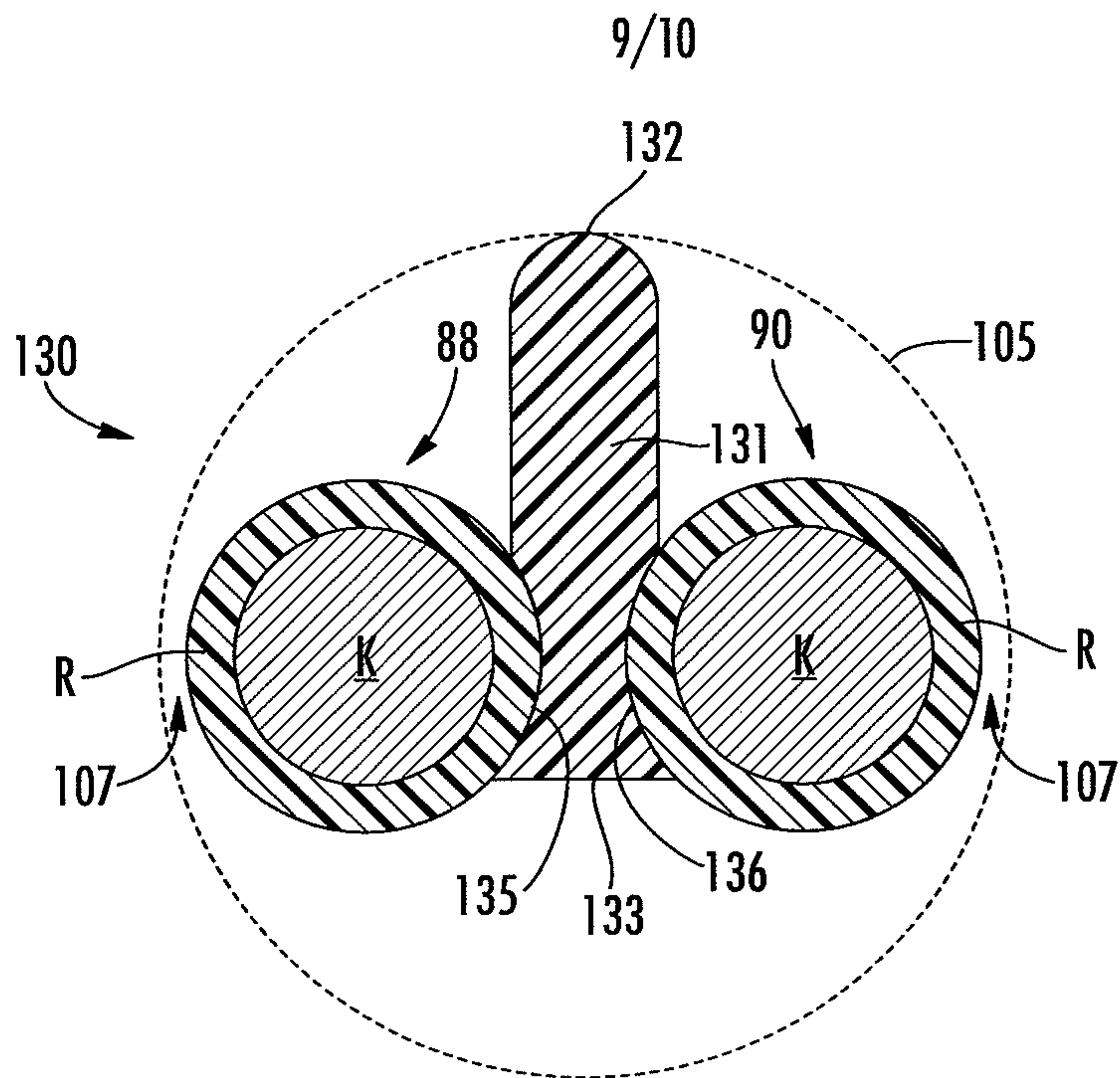

FIG. 13

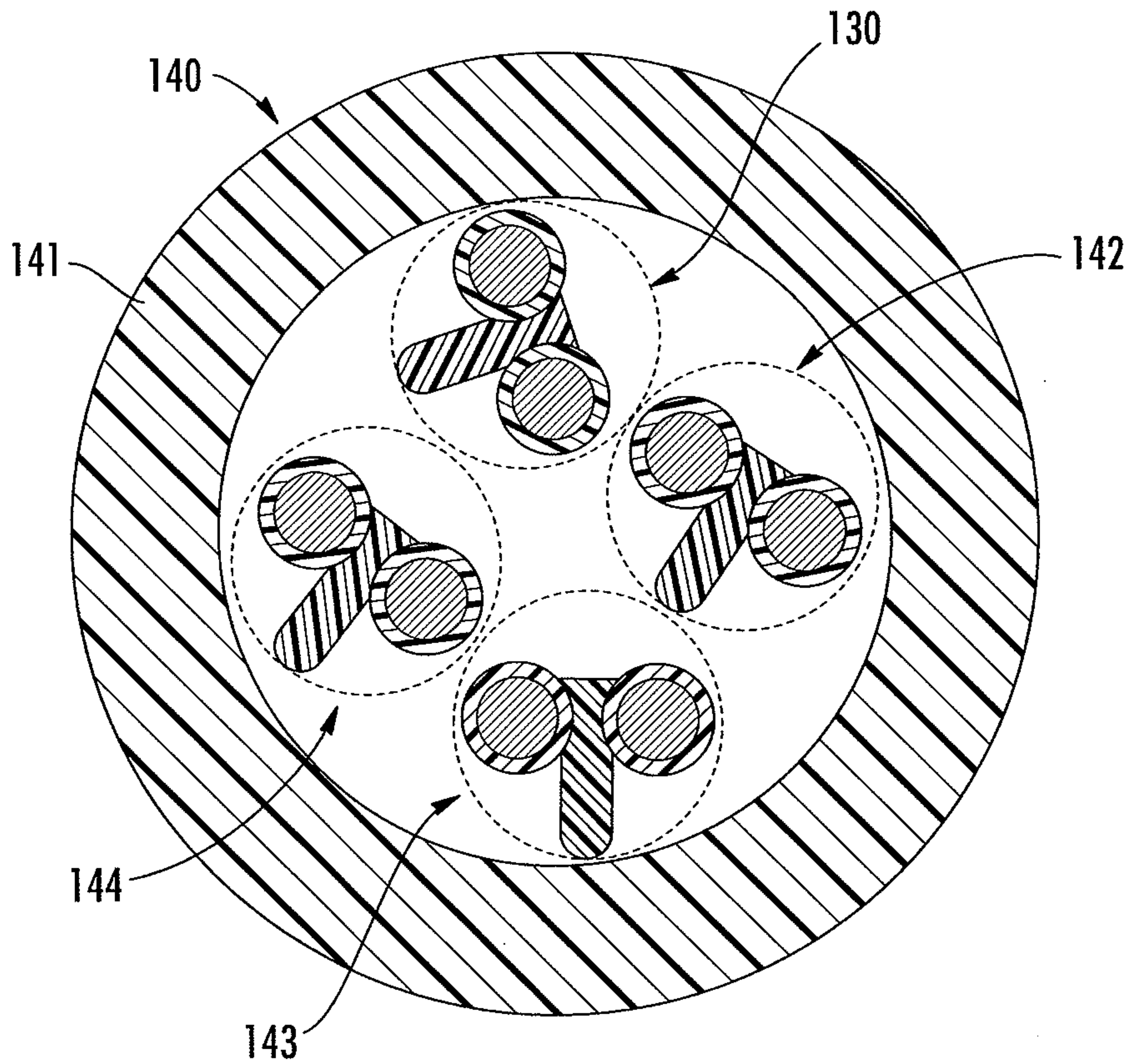

FIG. 14

10/10

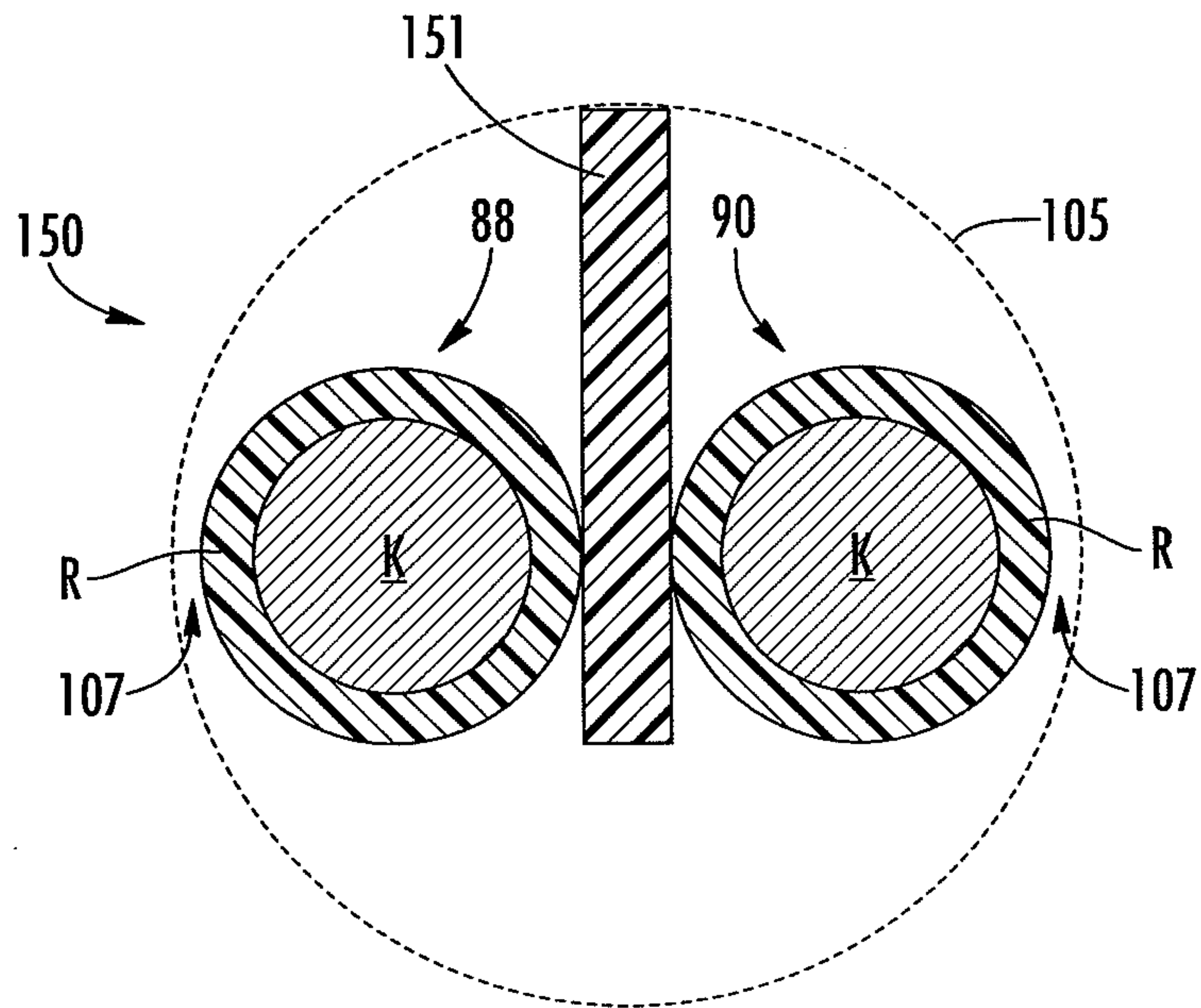

FIG. 15

