

(19) World Intellectual Property Organization
International Bureau



(43) International Publication Date
4 August 2011 (04.08.2011)

(10) International Publication Number
WO 2011/094440 A1

(51) International Patent Classification:

A61M 25/00 (2006.01) A61M 39/22 (2006.01)
A61M 25/06 (2006.01) A61B 17/34 (2006.01)

(21) International Application Number:

PCT/US2011/022768

(22) International Filing Date:

27 January 2011 (27.01.2011)

(25) Filing Language:

English

(26) Publication Language:

English

(30) Priority Data:

12/696,837 29 January 2010 (29.01.2010) US

(71) Applicant (for all designated States except US): **ABBOTT VASCULAR INC.** [US/US]; 3200 Lakeside Drive, Santa Clara, CA 95054-2807 (US).

(72) Inventor; and

(75) Inventor/Applicant (for US only): **LAVEILLE, Kao, Voss** [US/US]; 2832 Hallmark Rd., Belmont, CA 94002 (US).

(74) Agents: **TAYLOR, Paul, N.** et al.; Workman Nydegger, 60 East South Temple, 1000 Eagle Gate Tower, Salt Lake City, UT 84111 (US).

(81) Designated States (unless otherwise indicated, for every kind of national protection available): AE, AG, AL, AM,

AO, AT, AU, AZ, BA, BB, BG, BH, BR, BW, BY, BZ, CA, CH, CL, CN, CO, CR, CU, CZ, DE, DK, DM, DO, DZ, EC, EE, EG, ES, FI, GB, GD, GE, GH, GM, GT, HN, HR, HU, ID, IL, IN, IS, JP, KE, KG, KM, KN, KP, KR, KZ, LA, LC, LK, LR, LS, LT, LU, LY, MA, MD, ME, MG, MK, MN, MW, MX, MY, MZ, NA, NG, NI, NO, NZ, OM, PE, PG, PH, PL, PT, RO, RS, RU, SC, SD, SE, SG, SK, SL, SM, ST, SV, SY, TH, TJ, TM, TN, TR, TT, TZ, UA, UG, US, UZ, VC, VN, ZA, ZM, ZW.

(84) Designated States (unless otherwise indicated, for every kind of regional protection available):

ARIPO (BW, GH, GM, KE, LR, LS, MW, MZ, NA, SD, SL, SZ, TZ, UG, ZM, ZW), Eurasian (AM, AZ, BY, KG, KZ, MD, RU, TJ, TM), European (AL, AT, BE, BG, CH, CY, CZ, DE, DK, EE, ES, FI, FR, GB, GR, HR, HU, IE, IS, IT, LT, LU, LV, MC, MK, MT, NL, NO, PL, PT, RO, RS, SE, SI, SK, SM, TR), OAPI (BF, BJ, CF, CG, CI, CM, GA, GN, GQ, GW, ML, MR, NE, SN, TD, TG).

Published:

- with international search report (Art. 21(3))
- before the expiration of the time limit for amending the claims and to be republished in the event of receipt of amendments (Rule 48.2(h))

(54) Title: EXPANDABLE INTRODUCER SHEATHS AND METHODS FOR MANUFACTURE AND USE

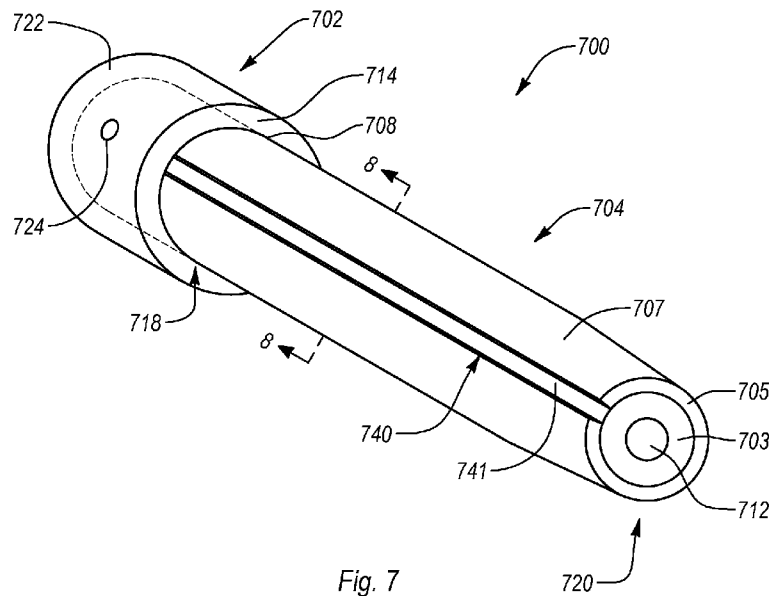
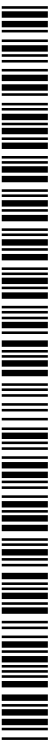

Fig. 7

(57) Abstract: An introducer sheath (700) is disclosed. The introducer sheath may include a tubular portion (704) extending between a proximal end (718) and a distal end (720). The tubular portion may include an inner portion (703) forming a lumen (712) and an outer portion (705) disposed partially around the inner portion. The inner portion and the outer portion may extend between the proximal end and the distal end. At least a portion of the inner portion may be exposed between the proximal end and the distal end. A method for manufacturing an introducer sheath is disclosed.



WO 2011/094440 A1

EXPANDABLE INTRODUCER SHEATHS AND METHODS FOR MANUFACTURE AND USE

CROSS-REFERENCE TO RELATED APPLICATIONS

5 [0001] This application claims priority to United States Patent Application Serial No. 12/696,837, filed January 29, 2010, and entitled "Expandable Introducer Sheaths and Methods for Manufacture and Use" which is a continuation-in-part of United States Patent Application Serial No. 11/427,308, entitled "Expandable Introducer Sheath", filed June 28, 2006, which is incorporated herein by reference in its entirety. This application
10 also relates to United States Patent Application Serial No. 11/427,301, entitled "Modular Introducer and Exchange Sheath", filed June 28, 2006, and United States Patent Application Serial No. 11/427,306, entitled "Introducer Sheath", filed June 28, 2006, each of which are incorporated herein by reference in its entirety. This application also incorporates by reference United States Patent Nos. 4,798,594, 5,176,652, 5,453,095, and
15 5,807,350 in their entireties.

BACKGROUND OF THE DISCLOSURE

1. The Field of the Disclosure

[0002] The present disclosure relates generally to medical devices and methods.
20 More particularly, embodiments of the disclosure relate to expandable medical devices, such as introducer sheaths, for use during medical procedures.

2. The Relevant Technology

[0003] A wide variety of devices have been developed for medical use. One such
25 device is an introducer sheath that facilitates access to body lumen at an access site. Conventionally, introducer sheaths are formed of three or more components that require assembly: a sheath portion, a hub, and a hemostasis valve disposed within the hub. A suitable example of such an assembly is shown in U.S. Patent No. 5,807,350, which depicts an introducer sheath having a construction similar to that described above, the
30 entirety of which is hereby incorporated by reference.

[0004] In practice, introducer sheaths are often used to access a vessel or artery to allow a surgical or medical procedure to be performed. The introducer sheath is generally inserted into a patient's vasculature using the modified Seldinger technique. In the Seldinger technique, a needle is first inserted into the vessel and then followed by a guide

wire through the needle. Next, the needle is removed and a sheath/dilator combination is advanced over the guide wire. The sheath/dilator expands the puncture in the vessel to a size suitable to receive the distal end of an introducer sheath. After the distal end of the sheath is disposed within the vessel, the dilator and guide wire are removed, thereby
5 allowing access to the vessel lumen through the introducer sheath.

[0005] There are an increasing number of medical procedures that can be performed using sheaths. Medical procedures such as angioplasty, stenting, and intraaortic therapy, are examples of procedures that can include the use of introducer sheaths. In particular, the medical devices (e.g., catheters, balloon pumps) used in these procedures are
10 introduced through the sheath.

[0006] Some of these procedures unfortunately require removal of the sheath earlier than desired. For example, intraaortic balloon pump therapy for ventricular insufficiency is often performed using a sheath. In this procedure, a sheath is inserted into the femoral artery. Next, a balloon pump is introduced into the patient's vasculature through the
15 sheath and then guided to the aortic arch region. Once the balloon pump is properly positioned in the arch region, it is left in place until the ventricular insufficiency is improved to an acceptable level, which may take days.

[0007] In this procedure, the balloon pump is being inflated and deflated at a rate that typically matches the heart rate. Thus, the balloon pump is usually inflated during
20 ventricular diastole and deflated during ventricular systole. As a result of the use of the balloon pump for the intraaortic therapy, the balloon pump will be larger in size compared to when it was initially inserted through the sheath. As a result of the increased size, removal of the balloon pump also requires the removal of the sheath since the enlarged balloon pump cannot fit inside of the sheath tubing. One of the disadvantages of
25 removing the sheath along with the balloon pump is that the opportunity to close the vessel with any vessel closure device through the sheath is lost. Therefore it may be desirable to have expandable introducer sheaths and methods for manufacture and use.

[0008] There is therefore a need for a new introducer sheath to accommodate removal and/or insertion of devices that change in size or that do not work with conventional
30 sheaths. There is also a need for sheaths that have lower manufacturing costs.

BRIEF SUMMARY OF THE DISCLOSURE

[0009] These and other limitations are overcome by embodiments of the disclosure, which relates to medical devices and in particular to expandable introducer sheaths.

Embodiments of the disclosure provide several designs and methods of manufacture of an expandable introducer sheath. One embodiment is an introducer sheath formed as a unitary device using, for example, an injection molding process or a co-extrusion process.

5 [0010] In one configuration of an expandable introducer sheath, one or more materials are used to form the sheath. At least one of the materials provides elasticity. The elasticity enables the sheath to expand, thereby accommodating the introduction and/or removal of medical devices that could not previously be accommodated.

[0011] In one configuration, the introducer sheath includes a hub portion and a
10 tubular portion. A valve member (such as a hemostasis valve) can be disposed into the hub portion either during the molding process or after the initial molding process. The hemostasis valve can be retained either by an additional element such as a cap or through an element formed during the molding process or during a subsequent molding process.

[0012] The tubular portion can include a sheath portion and an elastic portion, which
15 can be formed as a unitary portion through injection molding or co-extrusion processes, for example. The elastic portion of the sheath may be an elastomer that is integrated with another material in the sheath portion that provides rigidity and/or prevents a lumen of the tubular portion from collapsing. When a medical device is withdrawn, for example, the elastic portion can expand thereby permitting the medical device to be withdrawn without
20 splitting the introducer sheath. Advantageously, this enables the use of a subsequent medical device, such as a vessel closure device, to be introduced through the intact sheath, whether or not the vessel closure device splits or cuts the introducer sheath during use.

[0013] An embodiment of an introducer sheath is described. The introducer sheath
25 includes a tubular portion extending from the hub portion. The tubular portion includes an inner portion forming a lumen extending from a distal end toward a proximal end. The tubular portion also includes an outer portion disposed partially around the inner portion. The outer portion extends from the distal end toward the proximal end. At least a portion of the inner portion is exposed between the proximal end and the distal end.

30 [0014] A further embodiment of an introducer sheath is described. The introducer sheath includes a tubular portion extending between a proximal end and a distal end. The tubular portion includes an inner portion forming a first lumen and a second lumen. The tubular portion also includes an outer portion disposed partially around the inner portion. The inner portion and the outer portion extend between the proximal end and the distal

end. At least a portion of the inner portion is exposed between the proximal end and the distal end.

5 [0015] A still further embodiment of an introducer sheath is described. The introducer sheath includes a hub portion and a tubular portion extending from the hub portion and extending between a proximal end and a distal end. The tubular portion includes an inner portion forming a first lumen and a second lumen. The tubular portion also includes an outer portion disposed partially around the inner portion. The inner portion and the outer portion extend between the proximal end and the distal end. At least a portion of the inner portion being exposed between the proximal end and the distal end.

10 [0016] In some embodiments, the lumen may be expandable from a first inner dimension to a second inner dimension. The first inner dimension, in further embodiments, may be about six French and/or the second inner dimension may be about ten French.

15 [0017] The outer surface of the outer portion, in some embodiments, includes at least one aperture between the proximal end and the distal end. In further embodiments, the aperture extends from the distal end to the proximal end. The outer surface of the outer portion, in still further embodiments, includes a plurality of apertures oriented between the proximal end and the distal end.

20 [0018] In some embodiments, at least one of the tubular inner portion and the tubular outer portion may include an entry portion at the distal ends. The entry portion may be configured to facilitate entry of a medical device being withdrawn back through at least one of the tubular inner portion and the tubular outer portion. At least one of the tubular inner portion and the tubular outer portion may expand to accommodate the medical device without splitting the tubular member.

25 [0019] In some embodiments, the introducer sheath may include a fluid port associated with the hub portion to facilitate the introduction or removal of fluid from vasculature. The fluid port, in further embodiments, may include an alignment mechanism that aligns a medical device introduced through the sheath.

30 [0020] The hub portion, in some embodiments, may include a valve member that seals the hub portion. In further embodiments, the valve member may include an elastomeric body having at least one slit formed therein to allow selective insertion and removal of a medical device while maintaining a fluid tight seal around the medical device.

[0021] In some embodiments, the distal end of the hub portion may include a transition from the distal end of the hub portion to the proximal end of at least one of the tubular inner portion and the tubular outer portion. The introducer sheath, in further embodiments, may include a strain relief at the transition. In still further embodiments, the tubular portion may include a tapered end formed at the distal end of the tubular member.

[0022] An embodiment of a method for manufacturing an introducer sheath is described. The method includes forming an inner portion of a tubular portion. The tubular portion extends between a proximal end and a distal end. The inner portion defines a lumen. The method includes forming an outer portion around the inner portion. The outer portion encloses less than the entirety of the outer surface of the inner portion between the proximal end and the distal end.

[0023] In some embodiments, the first material may include expandable PTFE. The method, in further embodiments, may include forming a hub portion having a lumen formed therein extending from at least one of the tubular inner portion and the tubular outer portion. In still further embodiments, forming the inner portion, the outer portion, the hub portion, or combinations thereof may include using an injection molding process, an overmolding process, an extrusion process, a co-extrusion process, a bump extrusion process, other processes, or combinations thereof. The hub portion and at least one of the tubular inner portion and the tubular outer portion, in yet further embodiments, may be formed as a unitary member.

[0024] An embodiment of a method for performing a medical procedure is described. The method includes introducing a sheath into a lumen of a patient. The sheath has a first unexpanded dimension. The method includes inserting a first medical device having an outer dimension into the lumen through the sheath to perform a medical procedure. At least a tubular member of the sheath expands to a second expanded dimension to accommodate the outer dimension of the first medical device.

[0025] In some embodiments, the method may include inserting a second medical device through the sheath. Inserting a second medical device through the sheath, in further embodiments, may include introducing a vessel closure device through the sheath and/or closing the lumen of the patient with the vessel closure device. In still further embodiments, The sheath may include a tubular portion extending from the hub portion. The tubular portion, in yet further embodiments, may include at least one elastic portion elastically deformable to increase a cross sectional area of the tubular portion.

[0026] Additional features and advantages of the disclosure will be set forth in the description which follows, and in part will be obvious from the description, or may be learned by the practice of the disclosure. The features and advantages of the disclosure may be realized and obtained by means of the instruments and combinations particularly pointed out in the appended claims.

BRIEF DESCRIPTION OF THE DRAWINGS

[0027] In order that the manner in which the above-recited and other advantages and features of the disclosure are obtained, a more particular description of the disclosure briefly described above will be rendered by reference to specific embodiments thereof which are illustrated in the appended drawings. Understanding that these drawings depict only typical embodiments of the disclosure and are not therefore to be considered limiting of its scope, the disclosure will be described and explained with additional specificity and detail through the use of the accompanying drawings in which:

[0028] Figure 1 is a plan view of an exemplary embodiment of an introducer sheath in accordance with the present disclosure;

[0029] Figure 2 illustrates a cross sectional view of one embodiment of the introducer sheath in Figure 1;

[0030] Figure 3 illustrates a cross sectional view of another embodiment of the introducer sheath in Figure 1;

[0031] Figure 4 illustrates a cross sectional view of yet another embodiment of the introducer sheath in Figure 1;

[0032] Figure 5 illustrates a cross sectional view of another embodiment of the introducer sheath in Figure 1;

[0033] Figure 6A illustrates an introducer sheath prior to insertion of a medical device;

[0034] Figure 6B illustrates an introducer sheath prior to removal of a medical device that has changed size during use;

[0035] Figure 6C illustrates an embodiment of the introducer sheath during removal of the medical device that has changed size during use;

[0036] Figure 6D illustrates the use of a vessel closure device that is introduced through the sheath after the medical device illustrated in Figures 6A and 6B has been withdrawn;

[0037] Figure 7 illustrates a perspective view of an embodiment of an introducer sheath;

[0038] Figure 8 illustrates a cross-sectional view of the tubular portion of the introducer sheath of Figure 7 along line 8-8 of Figure 7 in an unexpanded state;

5 [0039] Figure 9 illustrates a cross-sectional view of the tubular portion of the introducer sheath along line 8-8 of Figure 7 in an expanded state;

[0040] Figure 10 illustrates a cross-sectional view of another embodiment of an introducer sheath in an unexpanded state;

[0041] Figure 11 illustrates a perspective view of a further embodiment of an
10 introducer sheath;

[0042] Figure 12 illustrates a perspective view of yet another embodiment of an introducer sheath.

DETAILED DESCRIPTION

15 [0043] Embodiments of the disclosure relate to a device that is expandable to cooperate with medical devices that may have a larger dimension and/or may become enlarged in dimension during use. For instance, in one configuration, the device may be an expandable introducer sheath that may accommodate removal of enlarged medical devices without removing the introducer from the delivery site. As such, the sheath or at
20 least a portion of the introducer sheath can expand to accommodate the introduction and/or removal of medical devices that could not ordinarily be accommodated in conventional sheaths. At the same time, the sheath may be formed to have desirable stiffness, kink resistance, flexibility, other characteristics, or combinations thereof for insertion and positioning in at least a portion of a body lumen. Embodiments of the
25 sheath are depicted in the drawings, which are not necessarily to scale and are not intended to limit the scope of the disclosure. It will be understood that the benefits of the present disclosure are not limited to application with an introducer sheath. Rather, other medical devices may be modified based upon the teachings contained herein such that they to can provide the functionality of accommodating removal of larger and/or enlarged
30 medical devices. Furthermore, at least one embodiment described herein may provide expandability to reduce a dimension of the introducer sheath.

[0044] Turning to the introducer sheath in accordance with the present disclosure, the sheath will be described herein as having portions or members, though it shall be understood that the sheath as described herein can be formed as a unitary unit, formed, by

way of example, using a co-extrusion process, an injection molding process, other processes, or combinations thereof or a sheath fabricated from the assembly of separate parts. As such, the various members or portions are used herein for clarification only and in no way limit the applicability of description herein to other configurations of the sheath and/or medical devices.

[0045] Generally stated, an exemplary introducer sheath may include a hub member or portion having a proximal end and a distal end. The proximal end of the sheath may be configured to receive a flexible valve member therein. The sheath may further include an elongated tubular member or portion generally extending from the distal portion of the hub portion. The elongated tubular portion, in one configuration, may be generally axially aligned with an axis of the hub portion, with the lumen of the tubular portion being aligned with a lumen of the hub portion. Alternatively, the lumen of the tubular portion may be aligned with a lumen of the hub portion, whether or not axially aligned. The aligning of the lumens may occur during manufacture, such as when the hub portion and the sheath are formed as a single integrated unit or when separate components are joined together. In one embodiment, the tubular portion may be configured to expand while still providing the necessary stiffness and/or kink resistance to the sheath.

[0046] An introducer sheath or portions thereof can be formed using one or more materials. Typically, the materials used in forming the introducer sheath include medical grade synthetic materials or plastics. Exemplary materials may include, but are not limited to, flexible PVC, polyurethane, silicone, linear low-density polyethylene (“LLDPE”), polyethylene, high density polyethylene, (“DHPE”), polyethylene-lined ethylvinyl acetate (“PE-EVA”), polypropylene, latex, thermoplastic rubber, polytetrafluorethylene (PTFE), expandable polytetrafluorethylene (ePTFE), fluoroethylene-propylene (FEP), perfluoralkoxy (PFA), ethylene-tetrafluoroethylene-copolymer (ETFE), ethylene-chlorotrifluoroethylene (ECTFE), polychlorotrifluoroethylene (PCTFE), polyimide (PI), polyetherimide (PEI), polyetherketone (PEEK), polyamide-imide (PAI), other fluoropolymers, and the like.

[0047] Exemplary materials used in the sheath or a portion of the sheath may include elastomers or thermoplastic elastomers. Examples of elastomers include, but are not limited to, natural rubber, silicone rubber, polyurethane rubber, polybutadiene, polyisoprene, chlorosulfonated polyethylene, polysulfide rubber, epichlorohydrin rubber, resilin, ethylene propylene rubber, and the like or any combination thereof. These materials may provide the elasticity that enables the sheath to expand and/or contract to

accommodate the removal/insertion of a medical device as required. Other materials that can be used may include, but are not limited to, dip coated type silicones.

[0048] In other embodiments, the materials suitable for use in an introducer sheath may be configured to have chemical resistance and/or crack resistance and/or to be non-toxic, Food and Drug Administration (“FDA”) compliant, non-electrically conductive, dimensionally stable, or combinations thereof and/or may be sterilized by ethylene oxide, gamma radiation, autoclave, UV light, ozone, and the like.

[0049] In addition, the selection of materials for a particular sheath may depend on a variety of factors that may include, but are not limited to, a particular stiffness and/or flexibility of the sheath or any portion of the sheath, including the desired column stiffness and strength to enable insertion of the sheath, a particular shear or split strength for the sheath or any portion of the sheath, the ability to resist kinking, and the like. For example, the material used for the tubular portion of the introducer sheath may be selected based on shear strength or how easily it can be split. Further, certain features of the sheath may be formed to enhance certain characteristics. For example, a strain relief portion may be formed so as to resist kinking while the elongated tubular portion may be formed to facilitate splitting.

[0050] When more than one material is used to form the sheath or to form specific portions of the introducer sheath, the materials may be selected, in addition to the factors identified herein, based on a bond strength between the materials and/or on the elasticity of a particular material. The bond strength, for example, may have an impact on the splitability of the sheath or of a portion of the sheath. The bond strength may also affect the ability of the sheath to expand without splitting.

[0051] When an elastomer is used in the sheath or a portion of the sheath, the elasticity of the elastomer may enable the sheath or a portion of the sheath to at least partially deform, resiliently deform, elastically, or combinations thereof expand as needed to accommodate a medical device and/or then return or substantially return to its configuration prior to deforming or expanding. Advantageously, the ability to deform and/or expand may permit a device, such as an expanded or expandable balloon, to be withdrawn through the sheath without removing the sheath, for example from a patient’s vasculature. This may maintain access to the patient’s vasculature without the difficulty of inserting another sheath or medical device through the puncture site. Further, maintaining the introducer sheath in place may allow a physician or technician to insert

one or more additional medical devices, such as a vessel closure device, using the introducer sheath.

[0052] Referring now to Figure 1, there is shown an exemplary embodiment of an introducer sheath 100. The introducer sheath 100 may include a hub portion 102, which
5 may include a proximal end 116 and a distal end 114, and a tubular portion 104. Extending from the proximal end 116 toward the distal end 114 is a lumen 110. This lumen 110 may cooperate with a medical device (not shown), such as a vessel closure device, insertable therethrough. In the illustrated configuration, the lumen 110 may taper or transition from one cross-sectional configuration to another cross-sectional
10 configuration near the distal end 114 to meet or intersect with a lumen 112 of the tubular portion 104. It will be understood that the lumen 110 can have a generally uniform cross-section along its length rather than tapering at its distal end. More generally, the lumen 110 may include one or more transitional portions based upon the desired configuration and use with other medical devices.

[0053] The elongated tubular portion 104 of the introducer sheath 100 may extend
15 from the distal end 114 of the hub portion 102. The tubular portion 104 may include a distal end 120 and a proximal end 118. The proximal end 118 may be integrally formed with the distal end 114 of the hub portion 102 or may be mounted or coupled to the distal end 114 through a friction fit, mechanical bonding, adhesives, thermal or chemical
20 bonding, combinations thereof or other manufacturing techniques usable to mount, couple or attach two medical components. The distal end 120 of the tubular portion 104 may include a tapered portion 106 to facilitate insertion into a body lumen. This tapered portion 106 may be formed during or after the initial forming process of the introducer sheath 100. For instance, when the introducer sheath 100 is formed through a molding or
25 extrusion process, the tapered portion 106 may be formed as part of this process. Alternatively, the tapered portion 106 may be formed by heat forming, grinding, or other methods that result in a thinner wall thickness following the above-described molding or extrusion process or as part of a milling, machining, or similar process.

[0054] Optionally disposed at the transition between the hub portion 102 and the
30 tubular portion 104 is a strain relief portion 108. The strain relief portion 108 would be disposed adjacent the distal end 114 of the hub portion 102 and adjacent the proximal end 118 of the elongate tubular portion 104. The strain relief 108 would be configured to provide additional support to the proximal end 118 of the elongated shaft or member 104 to prevent kinking at the transition between the proximal end 118 of the elongated

member 104 and the distal end 114 of the hub portion 102. In one embodiment, the strain relief portion 108 may be formed by gradually increasing a thickness of tubular portion 104 at the transition between the tubular portion 104 and the hub portion 102. In other configurations, the strain relief portion 108 may include webs, extensions, or other internal or external structures to increase the strength and/or stiffness of the introducer sheath 100 at the hub portion/tubular portion transition.

[0055] The tubular portion 104 of the introducer sheath may be expandable. More specifically, in the illustrated configuration of Figure 1, the tubular portion 104 is of an elastomeric material that allows the diameter of the tubular portion 104 to change as a medical device is inserted or removed from within the lumen 112. The elastomeric material may enable the tubular portion 104 to expand/contract or deform/reform, while maintaining sufficient column stiffness or strength so that the introducer sheath 100 may be inserted into the body lumen. In one configuration, the elastomeric material may be any of those described herein and such others as would be identified by in light of the teaching contained herein.

[0056] Optionally, the tubular portion 104 may also be configured to expand to a certain diameter at which point the tubular portion 104 is further configured to split or separate into one or more portions to accommodate other medical devices, such as, but not limited to vessel closure devices, as will be described in more detail hereinafter.

[0057] Generally, each of the hub portion 102 and the tubular portion 104 may have at least a portion of which that is generally cylindrical in nature. Although portions 102 and 104 may have generally cylindrical portions, other cross-sectional configurations are possible, such as but not limited to, oval, polygonal, elliptical, or other cross-sectional configurations usable for a medical device that is insertable into a body lumen.

[0058] As previously described herein, the introducer sheath 100 may be formed through an injection molding process. In an injection molding process, the hub portion 102 and the elongated tubular portion 104 are generally formed as a unitary member. Benefits of forming the introducer sheath 100 as a unitary member may include reduced costs, increased accuracy of part dimensions (i.e. dimension control) due to lack of assembly, alignment between the lumen 112 of the tubular portion 104 and the lumen 110 of the hub portion 102, and the balancing of mechanical properties across the entire sheath 100 or of any particular portion or member of the sheath 100. The thickness of the walls of the hub portion 102 and/or of the tubular portion 104 may be controlled and varied as desired during the injection molding process.

[0059] Although reference is made herein to fabrication of the introducer sheath 100 through use of injection molding techniques, various other techniques may be used. For instance, the introducer sheath may be fabricated using milling, grinding, laser treatment, etching, other techniques, or combinations thereof to form the introducer from a piece of material. Further, other techniques or methods may include those techniques generally used to fabricate medical devices.

[0060] With continued reference to Figure 1, disposed within the hub portion 102 is a flexible valve member 122. The valve member 122 may be integrally formed into the hub portion 102 during the molding process of the sheath 100, or may be inserted after the sheath 100 is integrally formed. For instance, the hub portion 102 may include a receiving feature 126, such as a groove or channel, to receive the valve member 122. The cooperation between the receiving feature 126 and the valve member 122 may result in a sealed hub portion 102. Stated another way, the valve member 122 may be self sealing once it is inserted into the hub portion 102 to limit fluid escaping from the body lumen.

[0061] The valve member 122 may be a seal and may have a variety of different configurations to seal the sheath 100. The valve member 122, for example, may have an elastomeric body, such as silicone rubber, with at least one slit and/or other collapsible openings formed therein to allow selective insertion and removal of medical devices or instruments, such as guide wires, catheters, balloon pumps, and other such devices. At the same time, the material and/or structure of the valve member 122 may maintain a fluid tight seal around the medical devices or instruments. Thus, leakage of blood or other bodily fluids may be limited, and entrance of unwanted air into the body may be limited.

[0062] It will be understood that the valve member 122 may be mounted and/or coupled to the hub portion 102 in a number of other manners to achieve the sealed configuration for the hub portion 102. For instance, the valve member 122 may be retained with a retaining cap (not shown) disposed adjacent the proximal end of the hub portion 102. In still another configuration, one or more flexible valves or valve members may be mounted within or to the proximal end 116 of the hub portion 102 through the use of one or more retaining caps, rings, or members. Although illustrated as a single member, the valve member 122 may be formed of multiple parts to provide the desired fluid sealing capabilities. Exemplary flexible membranes or valve members which can be utilized with the present disclosure are shown in United States Patents No. 4,798,594, 5,176,652, and 5,453,095 the entireties of which are hereby incorporated by reference.

[0063] More generally, the introducer sheath may have a configuration similar to the introducer sheath disclosed in United States Provisional Patent Application Serial Nos. 60/659,602, filed June 30, 2005, and entitled "Introducer Sheath" and 60/695,464, filed June 30, 2005, and entitled "Modular Introducer Sheath; and co-pending United States Patent Application Serial Nos. 11/427,301, filed June 28, 2006, and entitled "Modular Introducer and Exchange Sheath," and 11/427,306, filed June 28, 2006, and entitled "Introducer Sheath"), the entireties of which are hereby incorporated by reference. As such, the valve member 122 may be mounted in the hub portion 102 and the tubular portion 104 may have a similar configuration to the tubular member to the introducer sheath described in the above-identified applications.

[0064] Figure 1 also illustrates a port member 124, such as a luer port/fitting, which may be formed on the hub portion 102. The port member 124 may function as a fluid port for the sheath 100. Fluid (e.g., blood, antibiotics, plasma, saline, etc.) may be introduced and/or extracted through the fluid port 124. The port member 124 may be configured to align and/or selectively lock any device (e.g., a vessel closure device, a catheter) used in conjunction with the sheath 100.

[0065] Figures 2-5 illustrate various configurations of the tubular portion of the introducer sheath of the present disclosure. During the insertion/extraction of a medical device or instrument, the tubular portion can deform/form or expand/contract as needed. Thus, the cross sectional area of the tubular portion may change during a medical procedure. In one example, the tubular portion can expand in diameter from a first position to a second position having a diameter greater than the first position as a medical device is either withdrawn or inserted therethrough. The tubular portion can also return to or substantially to the first position following withdrawal or insertion. The illustrated configurations of the tubular portion each have a sheath portion and an elastic portion to provide the desired elasticity, stiffness, or strength. The sheath portion and the elastic portion can be formed from different materials as illustrated in Figures 2-4 discussed below. Alternatively, and as illustrated in Figure 5, the tubular portion can be fabricated from a single material, with the elastic portions being defined through the formation of lumens in the tubular portion. The inclusion of lumens or of elastomeric materials in the formation of an introducer sheath enable the sheath to deform/form or expand/contract as described herein.

[0066] Although various features are illustrated in each Figure, any of the features in a particular Figure can be combined with features illustrated in another Figure. Further,

the sheath portion and/or elastic portion are examples of one structure capable of performing the function of means for expanding a tubular portion to accommodate the insertion or removal of a medical device.

[0067] Turning now to Figure 2, illustrated is a tubular portion, identified by reference numeral 200, which can be used with the introducer sheath of the present disclosure, i.e., can function as the tubular portion 104 of Figure 1, i.e., function to expand/contract or deform/reform to enable withdrawal of a medical device that may have enlarged in diameter during use. The tubular portion 200 can include at least one sheath portion 204 and at least one elastic portion 202. The sheath portion 204 is typically formed of a first material and the elastic portion 202 is often formed of a second material. In Figure 2, the sheath portion 204 can be formed in strips that run along the length of the tubular portion 200 from the distal end 220 toward the proximal end 218, although the strips may have a shorter length. In some embodiments, the strips extend into the distal end 114 (Figure 1) of the hub portion 102 (Figure 1). The elastic portion 202 can be formed in strips in this embodiment such that each strip of the elastic portion 202 is adjacent to strips of the sheath portion 204.

[0068] The elastic portion 202 can be an elastomer that is bonded to the sheath portion 204. In Figure 2, each strip of the elastic portion 202 is bonded on each side to adjacent strips of the sheath portion 204. The elastic portion 202 enables the tubular portion 200 to expand or deform such that the interior diameter or cross-sectional area of the lumen can change or increase. The diameter or cross sectional area of the lumen 212 can expand in certain locations and is not required to expand along the entire length of the tubular portion 200. Further, different portions of the tubular portion 200 may expand at different rates and/or at different times. The actual expansion of the tubular portion 200 can depend on a particular medical device that is inserted or withdrawn and/or the material used to form the tubular portion 200. The sheath portion 204 can be selected to ensure that the lumen does not collapse when the tubular portion 200 is in a first or normal or unstressed position and to provide stiffness or rigidity to the tubular portion 200. Thus, the sheath portion 204 provides rigidity, flexibility, and the like or any combination thereof. In some embodiments, the sheath portion 204 may also provide some elasticity to the tubular portion 200. Typically, however, the elastic portion 202 has more elasticity than the sheath portion 204.

[0069] Figure 2 also illustrates an optional entry portion 228 to the lumen 212 of the tubular portion 200. The entry portion 228 can be shaped so as to facilitate entry of any

device that is entering the tubular portion 200 through the entry portion 228. The entry portion 228 can be formed when the tapered portion 206 is formed and the slope of the tapered portion 206 may be optionally altered to accommodate the entry portion 228. By shaping the entry portion 228, any device being withdrawn can more easily enter the lumen 212 of the tubular portion 200. In one embodiment, the entry portion 228 is concave and the edges at the distal end of the tubular portion 200 are smoothed. In other configurations, the entry portion 228 can be generally curved, smooth, or other configuration to aid with withdrawal of a medical device into the lumen 212.

[0070] The elongated tubular portion 200 can include an outer wall 208 and an inner wall 210 thereby defining a wall and a thickness of the wall. As with the lumen 212 (Figure 1), the lumen 212 extends along the length of the tubular portion 200. The width or diameter or cross sectional area of the lumen 212 can vary and may depend on intended use of the sheath 100. More particularly in this embodiment, the width or diameter or cross sectional area of the lumen 212 can vary or expand and contract during use as the elastic portion 202 changes shape, such as stretching and contracting. Because the hub portion 102 (Figure 1) and the tubular portion 200 are integrally formed in one configuration, the lumen 212 of the tubular portion 200 remains aligned with the lumen 110 (Figure 1) of the hub portion 102 (Figure 1) even though the lumen 212 expands, contracts, deforms, or reforms. It is contemplated that the wall thickness along the length of the elongated tubular portion 200 can be varied to vary mechanical properties of the sheath (stiffness, kink resistance, column strength, etc.).

[0071] Figure 3 illustrates a cross section of the tubular portion 200 of the introducer sheath as it moves from first, normal, or unstressed position to a second, expanded, or stressed position of the tubular portion 200. In the first position, identified by reference letter A, the elastic portion 202 of the tubular portion 200 is in a contracted or relaxed state and is bonded to the material of the sheath portion 204 at the bond points 230. The sheath portion 204 can be typically formed from a material such that the lumen 212 of the tubular portion 200 does not seal or close or collapse in the first position, and/or to provide stiffness or flexibility to the tubular portion 200.

[0072] In the second position, identified by reference letter B, the elastic portion 202 is expanded while the sheath portion 204 has not expanded (or has expanded less than the elastic portion 202) but is still bonded to the material at the bonds 230. In one embodiment, the sheath portion 204 may have some elasticity, but is generally configured to have less elasticity than the elastic portion 202. The bond strength at the bond 230 may

be selected to permit the expansion of the tubular portion 200 to a predetermined diameter or by a predetermined amount. When that diameter or amount is exceeded, the tubular portion 200 may split at the bonds 230 or at another location.

[0073] In some embodiments, a geometric pattern 232 is formed on the inner wall 210 or inner surface of the tubular portion 200, such as over all or at least one portion of the inner wall 210 or inner surface. Further, the geometric pattern 232 can be formed in or on the elastic portion 202 and/or the sheath portion 204. This geometric pattern 232 can be used to impart certain desirable mechanical properties to the tubular portion 200, such as, but not limited to, stiffness, strength, kink resistance, or flexibility to the tubular portion 200.

[0074] Various structures and configurations of the geometric pattern 232 can be used to provide the desired mechanical properties. For instance, in the illustrated configuration, the geometric pattern 232 is formed on one portion or surface of the inner wall 210 of the sheath portion 204 through use of one or more grooves or recesses. The illustrated geometric pattern 232 can represent a plurality of longitudinal grooves extending along an axis parallel to the longitudinal axis of the introducer sheath in a generally uniformly distributed pattern. In other configurations, however, the geometric pattern 232 can be unevenly distributed or a combination of uniformly and unevenly distributed over all or a portion of the inner wall 210 of the tubular portion 200. Further, the location of the grooves need not be parallel to the longitudinal axis of the introducer sheath, but can be transverse to such an axis and/or at any other angular orientation relative to the longitudinal axis.

[0075] It shall be understood that the pattern 232 as shown in Figure 3 should be considered exemplary and not limiting in any manner. It is contemplated that additional styles and types of patterns may be utilized in accordance with the present disclosure. For example, the pattern 232 may be a sinusoidal pattern disposed about the inner radius of the tubular portion 200. Alternatively, the pattern 232 may be configured to run along a different axis than one parallel to the longitudinal axis of the introducer sheath. For example, the pattern 232 may be formed as a spiral. The pattern 232 may also only extend partially along the length of the tubular portion 200.

[0076] Further, the pattern 232 can extend along the length of the tubular portion 200 from the proximal end 220 to the distal end 218 or along a portion of the length of the tubular portion 200. The pattern 232, or any portion thereof, may terminate prior to the proximal end 220 of the tubular portion 200 or extend partially into the hub portion 102

(Figure 1). The pattern 232 may also be a separation line, such as a pre-scored line. The pattern 232 may be designed to facilitate splitting of at least a portion of the introducer sheath. For example, the introducer sheath may split along all or a portion of the geometric pattern 232 after expanding past a predetermined limit.

5 [0077] Figure 4 illustrated is a cross section view of another tubular portion of an introducer sheath. This tubular portion 300 can be used with the introducer sheath 100 (Figure 1) and function to expand/contract or deform/reform to enable withdrawal of a medical device that may have enlarged in diameter during use. The tubular portion 300 has a similar configuration to that of tubular portion 200, and as such the description
10 related to tubular portion 200 also applies to tubular portion 300. As with tubular portion 200, the tubular portion 300 includes at least one elastic portion 302 and at least one sheath portion 304. The elastic portion 302 and the sheath portion 304 are mechanically coupled and/or bonded together to provide additional strength to the connection or coupling between the elastic portion 302 and the sheath portion 304. For instance, in
15 addition to or instead of a thermal or chemical bond between the elastic portion 302 and the sheath portion 304, a mechanical connection is made between the portions 302 and 304 to maintain the coupling or attachment of the elastic portion 302 and the sheath portion 304.

[0078] In the illustrated configuration of Figure 4, the mechanical coupling or
20 connection is facilitated by way of at least one interlocking feature 306 that cooperates and mechanically engages with a corresponding recess or receiving portion of the sheath portion 304. Each interlocking feature 306 can include at least one extension 308, which extends from the main body of the elastic portion 302, and at least one protrusion 310 extending from an end of the extension 308. With the at least one protrusion 310
25 extending from and being generally transverse to the extension 310, the at least one protrusion 310 aids with preventing detachment of the elastic portion 302 from the sheath portion 304 as the tubular portion 300 extends/contract or deforms/reforms. Although reference is made to the at least one protrusion 310 extending transverse to the at least one extension 308, one skilled in the art will appreciate that the at least one protrusion
30 310 can extend from the at least one extension 308 are other angular orientations while still being capable of preventing detachment.

[0079] The at least one interlocking feature 306 illustrated in Figure 4 can extend from a proximal end to a distal end of the tubular portion 300 and/or the introducer sheath. It will be understood, however, that the at least one interlocking feature 306 can

extend only part way from the distal end toward the proximal end, from the proximal end to the distal end, or at any location along the length of the tubular portion 300. Similarly, although the interlocking feature 306 is illustrated as extending from the elastic portion 302 toward the sheath portion 304, it will be understood that the corresponding recess or receiving portion of the sheath portion 304 can also be considered an interlocking feature. Further, the elastic portion 302 can be configured with the corresponding recess or receiving portion, while the sheath portion 304 includes the at least one extension 308 and/or the at least one protrusion 310.

[0080] The interlocking feature 306 of the tubular portion 300 of Figure 4 can be formed during the manufacturing process of the introducer sheath. For instance, the interlocking feature 306, with the corresponding recess or receiving portion, can be formed during injection molding or during a co-extrusion process of the tubular portion 300 and/or the introducer sheath. Alternatively, the interlocking feature 306 can be formed during manufacture of the elastic portion, such as by injection molding or a co-extrusion process, with the elastic portion being subsequently bonded or coupled to the sheath portion, or vice versa, through thermal bonding, chemical bonding, or other known technique to bond similar or dissimilar medical grade materials.

[0081] Turning now to Figure 5, illustrated is a cross section view of another tubular portion of an introducer sheath. This tubular portion 400 can be used with the introducer sheath 100 (Figure 1) and function to expand/contract or deform/reform to enable withdrawal of a medical device that may have enlarged in diameter during use.

[0082] Figure 5 illustrates a cross section of the tubular portion 400 of the introducer sheath as it moves from a first, normal, or unstressed position to a second, expanded or stressed position of the tubular portion 400. In the first position, again identified by reference letter A, the tubular portion 400 is in a contracted or relaxed state. The tubular portion 400 is similar to the tubular portion 104 (Figure 1), but further includes a plurality of lumens 420 disposed at least partially in a wall 422 defined by an outer wall 408 and an inner wall 410 of the tubular portion 400. The region of the tubular portion 400 containing the plurality of lumens 422 has a smaller wall thickness than the remainder of the tubular portion 400. These regions of smaller wall thickness function as elastic portions 402 of the tubular portion 400, while those regions of the wall 422 having no lumens 422 function as the sheath portion 404. Stated another way, the inclusion of the plurality of lumens 422 provides elasticity, expandability, or deformability to the tubular member 400 at the elastic portions 402. The number of lumens 422 in the tubular portion

400 can vary based upon the degree of flexibility desired for the tubular portion 400. Further the particular size, cross sectional shape, and/or ratio of lumen cross-sectional area to area of the wall can be varied to obtain different column strength, stiffness, kink resistance, elasticity, deformability, or other desirable mechanical properties or characteristics of the tubular member 400.

[0083] In the expanded position, identified by reference letter B, the at least one lumen 422 enables the relatively thinner wall portions of the tubular member 400 to stretch, thereby increasing the cross sectional area or shape of the tubular portion 400. After expansion, the tubular portion 400 can return to the first position.

[0084] Generally, by forming the tubular portion as a composite member using materials having the desired elastic properties, whether or not the tubular portion includes at least one lumen to increase the elasticity, expandability, or deformability of the tubular portion, mechanical properties of the tubular portion may be adjusted as desired. For example, if it is desirable to produce a sheath that is expandable during use, an elastomeric material can be selected along with another material having lower elastic properties. Forming a sheath using these materials, particularly in the tubular portion, provides the sheath with the ability to expand when subject to an applied force. As discussed herein, the configuration of the two or more materials in the sheath can vary and may depend on use. For example, one of the materials may be selected to stiffen the overall tubular portion, prevent kinking in the tubular portion, and the like while the other material is selected based on an elastic property. The bond between the first and second materials can be adjusted to facilitate expansion of the sheath at an appropriate time or for other reasons.

[0085] In addition, the use of a geometric pattern can also be combined with the expandability of the sheath. The geometric pattern formed on the inner wall may be used to assist in splitting the sheath during use at an appropriate time, such as when the diameter exceeds a predetermined limit during expansion of the tubular member.

[0086] As described above, two or more materials may be utilized to form the sheath in accordance with the present disclosure. For example, a different material maybe utilized to form the hub portion and one or more materials may be utilized to form the tubular portion of the sheath. Again, the selection of materials may depend on the end use of the sheath, properties of medical devices used with the sheath, and the like or any combination thereof. Although the present disclosure has been shown and described in accordance with specific embodiments these should not be considered limiting in any

manner. For example, multiple materials may be utilized to form a unitary sheath in accordance with the present disclosure, wherein multiple injection molding processes are performed simultaneously or in stages to form the unitary sheath in accordance with the present disclosure.

5 [0087] Embodiments of the introducer sheath described herein can be used in various medical procedures. In one example, a medical procedure often begins by introducing a sheath into body lumen, such as a patient's vasculature. After the sheath is properly introduced, a first medical device can be introduced through the sheath. During introduction of the first medical device, the sheath or at least the tubular portion of the
10 sheath may expand to accommodate a size of the first medical device.

[0088] After the first medical device has been introduced, the medical procedure may be performed. During this procedure, in one example, the size of the first medical device may change. During withdrawal of the first medical device, at least the tubular portion of the sheath can expand or deform to accommodate the increased size of the first medical
15 device. The expansion or change in cross sectional area can occur at different locations of the sheath or of the tubular portion as the first medical device is withdrawn.

[0089] After the first medical device is withdrawn, a second medical device, such as a vessel closure device, stent delivery device, or other medical device, can be introduced through the sheath. This newly inserted medical device can be used without prior
20 insertion of another introducer sheath. In the case of the vessel closure device, the vessel closure device can be placed in the desired location relative to the vessel wall and the introducer sheath removed before, during, or part of the vessel sealing process.

[0090] The above-described process is illustrated in more detail with reference to Figures 6A-6D. Figures 6A-6D illustrate an example of one configuration of an expandable introducer sheath during use in a medical procedure. A sheath 600, which
25 may include introducer sheaths 100, 700, 1100, 1200 and/or tubular portions 104, 200, 300, 400, 704, 804, 804', 1004, 1104, 1204 described in connection with Figures 1-5 and/or 7-12, can be inserted into a vessel or vasculature 610 of a patient. In this example, the tubular portion 604 of the sheath 600 is formed of a first elastomeric material 606 and
30 a second material 608. With the introducer sheath 600 in place one or more medical devices or instruments can be passed therethrough, such as through the lumens of the hub portion 602 and the tubular portion 604, to gain access to the vasculature 610 and more particular to a treatment site.

[0091] In one configuration, and with reference to Figure 6B, a medical device, such as, but not limited to, a dilation balloon or an intra-aortic balloon pump, identified by reference numeral 620, can be passed through the hub portion 602. During use of the medical device 620, the outside diameter of the medical device 420 increases in size from
5 when it was originally introduced into the vasculature 610 by way of the sheath 600. The structure and function of the tubular portion 604 and/or the introducer sheath 600 can, however, accommodate such a change and eliminates the need to remove the introducer sheath 600 with the medical device 620.

[0092] With continued reference to Figure 6B, once the medical procedure is
10 complete, the medical device 620 can be withdrawn until the medical device 620 contacts the distal end of the introducer sheath 600 and/or the entry portion 628 that facilitates entry of the medical device 620 back through the sheath 600. As the medical device 620 is withdrawn, its size introduces a force that causes the tubular portion 604 to expand as the first elastomeric material 606 flexes, expands, or deforms accommodate the pump
15 604, as illustrated in Figure 6C.

[0093] As the medical device 620 is withdrawn through the tubular portion 604, regions of the first elastomeric material 606 expand, such as in region 612, such that a cross sectional area of the lumen of the sheath 600 has increased at least at this location. The medical device 620 can therefore be withdrawn without splitting the sheath 600 or
20 without having to remove the sheath 600 from the vasculature 610 during removal of the medical device 620.

[0094] After the medical device 620 is withdrawn, Figure 6D illustrates that another medical device 422, such as a vessel closure device, a stent delivery device, or other medical device, can be introduced into the vasculature 620 via the sheath 600. Without
25 the expansion capability enabled by the embodiments disclosed herein, the sheath would have to be removed earlier than desired, which could preclude use of other medical devices, such as, but not limited to, the vessel closure device.

[0095] Figure 7 illustrates a perspective view of an embodiment of an introducer sheath 700. The introducer sheath 700 of the embodiment described herein and shown in
30 Figure 7 may be functionally similar to the introducer sheaths 100, 600, 1100, 1200 and/or tubular portions 104, 200, 300, 400, 604, 804, 804', 1004, 1104, 1204 described herein in connection with Figures 1-6 and/or 8-12 in most respects, wherein certain features may not be described in relation to this embodiment wherein those components may function in the manner as described above and are hereby incorporated into this

embodiment described below. Like structures and/or components are given like reference numerals.

[0096] The introducer sheath 700 may include a hub portion 702 with an elongate or tubular portion 704 extending therefrom. As illustrated, the hub portion 702 may include
5 a strain relief portion 708 to provide additional support to a proximal end 718 of the elongate portion 704 to prevent kinking at the transition between the proximal end 718 of the elongated portion 704 and a distal end 714 of the hub portion 702. The hub portion 702 may also include a valve member 722, such as a hemostatis valve, and a fluid port 724 configured to permit fluid (e.g., blood, antibiotics, plasma, saline, etc.) to be
10 introduced and/or extracted through the hub portion 702. The fluid port 724 may be configured to align and/or selectively lock any device (e.g., a vessel closure device, a catheter) used in conjunction with the sheath 700. Other combinations of structures of the hub portion 702 are possible.

[0097] The elongate portion 704 may extend between the proximal end 718 and a
15 distal end 720. The elongate portion 704 may include an inner portion 703 and an outer portion 705, with the inner portion 703 and/or the outer portion 705 extending between the proximal end 718 and the distal end 720 of the tubular portion 704.

[0098] As illustrated, the inner portion 703 may form a lumen 712. The lumen 712 may include an entry portion, such as entry portion 228 shown in Figure 2. The outer
20 portion 705 of the lumen 712 may be disposed partially around the inner portion 703. For example, at least a portion of the inner portion 703 may be exposed between the proximal end 718 and the distal end 720 of the tubular portion 704 by way of at least one aperture 740. In the present embodiment, the aperture 740 may extend from the proximal end 718 toward the distal end 720 and terminate at the distal end 720. In other embodiments, the
25 aperture 740 may extend from the proximal end 718 and terminate proximal the distal end 720. In still another configuration, the aperture 740 may be disposed between and spaced apart from either or both the proximal end 718 and the distal end 720. The aperture 740 may extend from an outer surface 707 of the outer portion 705 to an outer surface 741 of the inner portion 703. The aperture 740 may vary in size. For example, the aperture 740
30 as shown in Figure 7 may define a gap. In other embodiments, the aperture 740 may be smaller, like a slit. Although, regardless of the size of the aperture 740, as the sheath 700 expands, the aperture 740 will increase in size.

[0099] Figure 8 illustrates a cross-sectional view of the elongate portion 704 of the introducer sheath 700 of Figure 7 along line 8-8 of Figure 7 in an unexpanded state. The

lumen 712 of the introducer sheath 700 illustrated in Figure 8 is in an unexpanded state. The lumen 712 may include a first inner dimension 712a. The first inner dimension 712a may include a diameter, a cross-sectional area, a radius, an arc length, other dimensions, or combinations thereof. For example, the first inner dimension 712a may be a diameter
5 of about six French.

[00100] The inner portion 703 may include a first material that may include at least one relatively expandable material. The first material may provide lubricious properties to facilitate medical devices being inserted and/or removed through the lumen 712. For example, the first material may include ePTFE, which may provide both expandability
10 and lubricity.

[00101] The outer portion 705 may include a second material that may provide expandability and/or lubricity. For example, the second material may include an elastomeric material. In the present embodiment, the second material may be less expandable (i.e. may have a lower modulus of elasticity) than the first material of the
15 inner portion 703. In embodiments where the second material may be less expandable than the first material and despite the reduced expandability of the second material, the exposure of the inner portion 703 through at least a portion of the outer portion 705 may facilitate expansion of the inner portion 703. A less expandable second material may increase the longitudinal strength (i.e. resistance to buckling in the longitudinal direction)
20 and/or pushability of the introducer sheath while providing radial and/or other expandability of the introducer sheath through the more expandable first material.

[00102] The inner portion 703 and/or the outer portion 705 may be arranged to facilitate entry and/or exit of a medical device through the lumen 712 by expanding to accommodate the medical device without creating further apertures (not shown) in the
25 outer surface 707 of the tubular portion 704.

[00103] Figure 9 illustrates a cross-sectional view of the elongate or tubular portion 704' of the introducer sheath 700 along line 8-8 of Figure 7 in an expanded state. The elongate portion 704' of the embodiment described herein and shown in Figure 9 may be functionally similar to the introducer sheaths 100, 600, 700, 1100, 1200 and/or tubular
30 portions 104, 200, 300, 400, 604, 704, 804, 1004, 1104, 1204 described herein in most respects, wherein certain features may not be described in relation to this embodiment wherein those components may function in the manner as described above and are hereby incorporated into this embodiment described below. Like structures and/or components are given like reference numerals.

[00104] The elongate portion 704', the inner portion 703', the outer portion 705', the lumen 712', the aperture 740', other components of the introducer sheath 700, or combinations thereof, may increase in at least one dimension in the expanded state. The inner portion 703' and the outer portion 705' may expand in conjunction with the lumen 712'. The aperture 740' may expand circumferentially. Expansion of the aperture 740' may increase the size of the exposed portion of the inner portion 703' of the elongate portion 704'. The outer portion 705' may be disposed around less of the inner portion 703' in the expanded state.

[00105] The lumen 712' is shown in Figure 9 in the expanded state. The lumen 712' may include a second inner dimension 712a'. The second inner dimension 712a' may include a diameter, a cross-sectional area, a radius, an arc length, other dimensions, or combinations thereof. For example, the second inner dimension 712a' may be a diameter of about ten French. The lumen 712 (shown in Figure 8) may expand from a first inner dimension 712a to a second inner dimension 712a' of the lumen 712'. This expansion may be about sixty-five percent. For example, from about six French to about ten French. In other embodiments, the expansion may be more and/or less than about sixty-five percent. For example, it may be as little as about ten percent.

[00106] Figure 10 illustrates a cross-sectional view of another embodiment of an elongate or tubular portion 1004 of an introducer sheath in an unexpanded state. The tubular portion 1004 of the embodiment described herein and shown in Figure 10 may be functionally similar to the introducer sheaths 100, 600, 700, 1100, 1200 and/or tubular portions 104, 200, 300, 400, 604, 704, 804, 804', 1104, 1204 described herein in most respects, wherein certain features may not be described in relation to this embodiment wherein those components may function in the manner as described above and are hereby incorporated into this embodiment described below. Like structures and/or components are given like reference numerals. For example, the tubular portion 1004 may be used with the introducer sheath 700 to include a hub portion 702.

[00107] The tubular portion 1004 may extend between a proximal end (such as proximal end 718 shown in Figure 7) and a distal end (such as distal end 720 shown in Figure 7). The tubular portion 1004 may include an inner portion 1003 and an outer portion 1005. The inner portion 1003 and/or the outer portion 1005 may extend between the proximal end (such as proximal end 718 shown in Figure 7) and the distal end (such as distal end 720 shown in Figure 7) of the tubular portion 1004.

[00108] In the present embodiment, the inner portion 1003 may form at least two lumens 1012, 1013. The lumens 1012, 1013 may include an entry portion, such as entry portion 228 shown in Figure 2. The outer portion 1005 may be disposed partially around the inner portion 1003. For example, at least a portion of the inner portion 1003 may be exposed between the proximal end and the distal end of the tubular portion 1004. In 5 embodiments such as the present embodiment, multiple portions of the inner portion 1003 may be exposed.

[00109] The tubular portion 1004 may include at least one aperture 1040a. In the presently illustrated embodiment, the tubular portion 1004 may include a first aperture 10 1040a, a second aperture 1040b, and a third aperture 1040c. The apertures 1040a, 1040b, 1040c may expose at least a portion of the inner portion 1003 between the proximal end (shown as 718 in Figure 7) and the distal end (shown as 720 in Figure 7) of the tubular portion 1004.

[00110] For example, the first aperture 1040a may expose a portion of the inner 15 portion 1003 shown above the first lumen 1012, the second aperture 1040b may expose a portion of the inner portion 1003 shown between the first lumen 1012 and the second lumen 1013, the third aperture 1040c may expose a portion of the inner portion 1003 shown below the second lumen 1013, or combinations thereof. In other embodiments, more or fewer portions of the inner portion 1003 may be exposed. In the present 20 embodiment, at least one of the apertures 1040a, 1040b, 1040c may extend from the proximal end to the distal end. In other embodiments, the apertures 1040a, 1040b, 1040c may extend between but not including both the proximal end and the distal end. The apertures 1040a, 1040c may extend from an outer surface 1007 of the outer portion 1005 to an outer surface 1041 of the inner portion 1003.

[00111] The lumens 1012, 1013 are shown in Figure 10 in an unexpanded state. The 25 lumens 1012, 1013 may include first inner dimensions 1012a, 1013a, respectively. The first inner dimensions 1012a, 1013a may include a diameter, a cross-sectional area, a radius, an arc length, other dimensions, or combinations thereof. For example, the first inner dimension 1013a of the second lumen 1013 may be a diameter of about six French 30 in an unexpanded state.

[00112] The inner portion 1003 may include a first material that may include at least one relatively expandable material. The first material may provide lubricious properties to facilitate medical devices being inserted and/or removed through the lumen 1012. For

example, the first material may include ePTFE, which may provide both expandability and lubricity.

[00113] The outer portion 1005 may include a second material that may provide expandability and/or lubricity. For example, the second material may include an elastomeric material. In the present embodiment, the second material may be less expandable (i.e. may have a lower modulus of elasticity) than the first material of the inner portion 1003. In embodiments where the second material may be less expandable than the first material and despite the reduced expandability of the second material, the exposure of the inner portion 1003 through at least a portion of the outer portion 1005 may facilitate expansion of the inner portion 1003. A less expandable second material may increase the longitudinal strength (i.e. resistance to buckling in the longitudinal direction) and/or pushability of the introducer sheath while providing radial expandability of the introducer sheath through the more expandable first material.

[00114] The tubular portion 1004, the inner portion 1003, the outer portion 1005, the first lumen 1012, the second lumen 1013, the first aperture 1040a, the second aperture 1040b, the third aperture 1040c, other components of the introducer sheath (such as introducer sheath 700 shown in Figure 7), or combinations thereof, may increase in at least one dimension in the expanded state. The inner portion 1003 and the outer portion 1005 may expand in conjunction with the first lumen 1012 and/or the second lumen 1013. The apertures 1040a, 1040b, 1040c may expand circumferentially. Expansion of the apertures 1040a, 1040b, 1040c may increase the size of at least one of the exposed portions of the inner portion 1003 of the tubular portion 1004. The outer portion 1005 may be disposed around less of the inner portion 1003 in the expanded state.

[00115] The lumens 1012, 1013 may include second inner dimensions (not shown) in an expanded state. The second inner dimensions may include a diameter, a cross-sectional area, a radius, an arc length, other dimensions, or combinations thereof. For example, the second inner dimension of the second lumen 1013 may include a diameter of about ten French. The second lumen 1013 may expand from the first inner dimension 1013a to a second inner dimension (not shown) of the second lumen 1013. This expansion may be about sixty-five percent. For example, from about six French to about ten French. In other embodiments, the expansion may be more and/or less than about sixty-five percent. For example, it may be as little as about ten percent. The first inner dimension 1012a of the first lumen 1012 may expand in similar fashion.

[00116] The inner portion 1003 and/or the outer portion 1005 may be arranged to facilitate entry and/or exit of a medical device through the lumens 1012, 1013 by expanding to accommodate the medical device without creating further apertures (not shown) in the outer surface (not shown) of the tubular portion 1004.

5 [00117] Figure 11 illustrates a perspective view of a further embodiment of an introducer sheath 1100. The introducer sheath 1100 of the embodiment described herein and shown in Figure 10 may be functionally similar to the introducer sheaths 100, 600, 700, 1200 and/or tubular portions 104, 200, 300, 400, 604, 704, 804, 804', 1004, 1204 described herein in connection with Figures 1-10 and/or 12 in most respects, wherein
10 certain features may not be described in relation to this embodiment wherein those components may function in the manner as described above and are hereby incorporated into this embodiment described below. Like structures and/or components are given like reference numerals.

[00118] The elongate or tubular portion 1104 may extend between a proximal end
15 1118 and a distal end 1120. The tubular portion 1104 may include an inner portion 1103 and an outer portion 1105. The inner portion 1103 and/or the outer portion 1105 may extend between the proximal end 1118 and the distal end 1120 of the tubular portion 1104.

[00119] In the present embodiment, the inner portion 1103 may form a lumen 1112. In
20 other embodiments, the inner portion 1103 may form a plurality of lumens. The lumen 1112 may include an entry portion, such as entry portion 228 shown in Figure 2. The outer portion 1105 may be disposed partially around the inner portion 1103. For example, at least a portion of the inner portion 1103 may be exposed between the proximal end and the distal end of the tubular portion 1104. In the present embodiment,
25 multiple portions of the inner portion 1103 may be exposed.

[00120] The tubular portion 1104 may include at least one aperture. In the present
embodiment, the tubular portion 1104 may include a first aperture 1140a, a second aperture 1140b, a third aperture 1140c, a fourth aperture 1140d, a fifth aperture 1140e, and a sixth aperture 1140f. The apertures 1140a, 1140b, 1140c, 1140d, 1140e, 1140f may
30 expose at least a portion of the inner portion 1103 between the proximal end 1118 and the distal end 1120 of the tubular portion 1104.

[00121] The apertures 1140a, 1140b, 1140c, 1140d, 1140e, 1140f may expose various portions of the inner portion 1103. The apertures 1140a, 1140b, 1140c, 1140d, 1140e, 1140f may be longitudinally and/or axially oriented with respect to the lumen 1012 and/or

circumferentially oriented with respect to the proximal end 1118 and/or the distal end 1120 of the tubular portion 1104.

[00122] For example and as shown in Figure 11, the first aperture 1140a may expose a portion of the inner portion 1103 from the proximal end 1118 toward the distal end 1120, the second aperture 1140b may expose a portion of the inner portion 1103 longitudinally and circumferentially offset from the first aperture 1140a, the third aperture 1140c may expose a portion of the inner portion 1103 longitudinally and circumferentially offset from the first aperture 1140 and the second aperture 1140b, the fourth aperture 1140d may expose a portion of the inner portion 1103 longitudinally but not circumferentially offset from the third aperture 1140c, the fifth aperture 1140e may expose a portion of the inner portion 1103 longitudinally and circumferentially offset from the third aperture 1140c and circumferentially but not longitudinally offset from the fourth aperture 1140d, and the sixth aperture 1140f may expose a portion of the inner portion 1103 longitudinally but not circumferentially offset from the second aperture 1140b with a larger longitudinal offset from the second aperture 1140b than the third aperture 1140c though still longitudinally offset from the distal end 1120, such that nearly the entire length of the tubular portion 1104 may be exposed from the proximal end 1118 to the distal end 1120. In other embodiments, more or fewer portions of the inner portion 1103 may be exposed using more or fewer apertures in varying longitudinal and/or circumferential offsets and/or axial orientations with respect to the proximal end 1118, the distal end 1120, other apertures, or combinations thereof. In the present embodiment, none of the apertures 1140a, 1140b, 1140c, 1140d, 1140e, 1140f extend from the proximal end 1118 to the distal end 1120. In other embodiments, at least one of the apertures 1140a, 1140b, 1140c, 1140d, 1140e, 1140f may extend from the proximal end to the distal end. The apertures 1140a, 1140b, 1140c, 1140d, 1140e, 1140f may extend from an outer surface 1107 of the outer portion 1105 to an outer surface 1041 of the inner portion 1103.

[00123] The inner portion 1103 may include a first material that may include at least one relatively expandable material. The first material may provide lubricious properties to facilitate medical devices being inserted and/or removed through the lumen 1112. For example, the first material may include ePTFE, which may provide both expandability and lubricity.

[00124] The outer portion 1105 may include a second material that may provide expandability and/or lubricity. For example, the second material may include an

elastomeric material. In the present embodiment, the second material may be less expandable (i.e. may have a lower modulus of elasticity) than the first material of the inner portion 1103. In embodiments where the second material may be less expandable than the first material and despite the reduced expandability of the second material, the exposure of the inner portion 1103 through at least a portion of the outer portion 1105 may facilitate expansion of the inner portion 1103. A less expandable second material may increase the longitudinal strength (i.e. resistance to buckling in the longitudinal direction) and/or pushability of the introducer sheath while providing radial expandability of the introducer sheath through the more expandable first material.

5 [00125] The inner portion 1103 and/or the outer portion 1105 may be arranged to facilitate entry and/or exit of a medical device through the lumen 1112 by expanding to accommodate the medical device without creating further apertures (not shown) in the outer surface (not shown) of the tubular portion 1104.

[00126] Figure 12 illustrates a perspective view of yet another embodiment of an introducer sheath. The introducer sheath 1200 of the embodiment described herein and shown in Figure 12 may be functionally similar to the introducer sheaths 100, 600, 700, 1100, and/or tubular portions 104, 200, 300, 400, 704, 604, 804, 804', 1004, 1104 described herein in connection with Figures 1-11 in most respects, wherein certain features may not be described in relation to this embodiment wherein those components may function in the manner as described above and are hereby incorporated into this embodiment described below. Like structures and/or components are given like reference numerals.

15 [00127] The introducer sheath 1200 may include a hub portion 1202. The hub portion 1202 may include a flange 1201. The hub portion 1202 and/or the flange 1201 May configured to selectively connect to a medical device (not shown) to limit longitudinal and/or axial motion of the introducer sheath 1200 with respect to the medical device.

[00128] The elongate or tubular portion 1204 may extend between a proximal end 1218 and a distal end 1220. The tubular portion 1204 may include at least one inner portion 1203a, 1203b and an outer portion 1205. The inner portions 1203a, 1203b and/or the outer portion 1205 may extend between the proximal end 1218 and the distal end 1220 of the tubular portion 1204.

20 [00129] In the present embodiment, the inner portion 1003 may form at least two lumens 1212, 1213. In other embodiments, the inner portions 1203a, 1203b may form more or fewer lumens. The outer portion 1205 may be disposed at least partially around

the inner portions 1203a, 1203b. For example, at least a portion of at least one inner portion 1203a, 1203b may be exposed between the proximal end and the distal end of the tubular portion 1204. In other embodiments, multiple portions of the more or fewer inner portions may be exposed. For example in some embodiments, it may be desirable for a lumen, such as lumen 1212 to be less expandable than another lumen, such as lumen 1213 such that no portion or fewer portions of the inner portion, such as inner portion 1203a, may be exposed.

[00130] The tubular portion 1204 may include an aperture 1240. The aperture 1240 may be longitudinally and/or axially oriented with respect to the lumen 1012 and/or circumferentially oriented with respect to the proximal end 1218 and/or the distal end 1220 of the tubular portion 1204. In the present embodiment, the aperture 1240 may expose a portion of the inner portions 1203a, 1203b from the proximal end 1218 to the distal end 1220 in a generally helical manner. The axial orientation (i.e. pitch) of the aperture 1240 may be constant and/or vary along the length of the tubular portion 1204.

[00131] In other embodiments, more or fewer portions of the inner portions 1203a, 1203b may be exposed using more or fewer apertures in varying longitudinal and/or circumferential offsets and/or axial orientations with respect to the proximal end 1218, the distal end 1220, other apertures, or combinations thereof. In the present embodiment, the aperture 1240 extends from the proximal end 1218 to the distal end 1220. The aperture 1240 may extend from an outer surface (not shown) of the outer portion 1205 to an outer surface (not shown) of the inner portions 1203a, 1203b.

[00132] The inner portions 1203a, 1203b may include a first material. The first material may include at least one relatively expandable material. The first material may provide lubricious properties to facilitate medical devices being inserted and/or removed through the lumen 1212. For example, the first material may include ePTFE, which may provide both expandability and lubricity. In the present embodiment, the inner portions 1203a, 1203b may include the same first material. In other embodiments, the inner portions 1203a, 1203b may include different materials.

[00133] The outer portion 1205 may include a second material. The second material may provide expandability and/or lubricity. For example, the second material may include an elastomeric material. In the present embodiment, the second material may be less expandable (i.e. may have a lower modulus of elasticity) than the first material of the inner portions 1203a, 1203b. In embodiments where the second material may be less expandable than the first material and despite the reduced expandability of the second

material, the exposure of the inner portions 1203a, 1203b through at least a portion of the outer portion 1205 may facilitate expansion of the inner portions 1203a, 1203b. A less expandable second material may increase the longitudinal strength (i.e. resistance to buckling in the longitudinal direction) and/or pushability of the introducer sheath while providing radial expandability of the introducer sheath through the more expandable first material.

[00134] The first inner portion 1203a, the second inner portion 1203b, the outer portion 1205, or combinations thereof may be arranged to facilitate entry and/or exit of a medical device through the lumen 1212 by expanding to accommodate the medical device without creating further apertures (not shown) in the outer surface (not shown) of the tubular portion 1204.

[00135] The various introducer sheaths described herein that include an inner portion and an outer portion may be manufactured by forming the inner portion and forming the outer portion around the inner portion such that the outer portion encloses less than the entirety of the outer surface of the inner portion between the proximal end and a distal end. The tubular portion and/or hub portion of an introducer sheath may be manufactured using various processes. For example, the tubular portion and/or hub portion of an introducer sheath may be manufactured using an injection molding process, an overmolding process, an extrusion process, a coextrusion process, a bump extrusion process, other processes, or combinations thereof.

[00136] The present disclosure may be embodied in other specific forms without departing from its spirit or essential characteristics. The described embodiments are to be considered in all respects only as illustrative and not restrictive. The scope of the disclosure is, therefore, indicated by the appended claims rather than by the foregoing description. All changes which come within the meaning and range of equivalency of the claims are to be embraced within their scope.

CLAIMS

What is claimed is:

1. An introducer sheath comprising:
a tubular portion extending from said hub portion, said tubular portion including:
5 an inner portion forming a lumen extending from a distal end toward a proximal end; and
an outer portion disposed partially around said inner portion, said outer portion extending from said distal end toward said proximal end, at least a portion of said inner portion being exposed between said proximal end and said distal end.
10
2. The introducer sheath of claim 1, wherein said lumen is expandable from a first inner dimension to a second inner dimension.
3. The introducer sheath of claim 2, wherein said first inner dimension is about six
15 French and said second inner dimension is about ten French.
4. The introducer sheath of claim 1, wherein said outer surface of said outer portion includes at least one aperture between said proximal end and said distal end.
- 20 5. The introducer sheath of claim 4, wherein said aperture extends from said distal end to said proximal end.
6. The introducer sheath of claim 4, wherein said outer surface of said outer portion includes a plurality of apertures oriented between said proximal end and said distal end.
25
7. An introducer sheath comprising:
a tubular portion extending between a proximal end and a distal end, said tubular portion including:
an inner portion forming a first lumen and a second lumen; and
30 an outer portion disposed partially around said inner portion, said inner portion and said outer portion extending between said proximal end and said distal end, at least a portion of said inner portion being exposed between said proximal end and said distal end.

8. The introducer sheath of claim 6, wherein at least one of said tubular inner portion and said tubular outer portion further comprise an entry portion at said distal ends, said entry portion configured to facilitate entry of a medical device being withdrawn back through at least one of said tubular inner portion and said tubular outer portion, wherein at
5 least one of said tubular inner portion and said tubular outer portion expands to accommodate the medical device without splitting said tubular member.

9. An introducer sheath, comprising:
a hub portion; and
10 a tubular portion extending from said hub portion and extending between a proximal end and a distal end, said tubular portion including:
an inner portion forming a first lumen and a second lumen; and
an outer portion disposed partially around said inner portion, said inner
portion and said outer portion extending between said proximal end and said distal
15 end, at least a portion of said inner portion being exposed between said proximal end and said distal end.

10. The introducer sheath of claim 9, further comprising a fluid port associated with the hub portion to facilitate the introduction or removal of fluid from vasculature.
20

11. The introducer sheath of claim 9, wherein the hub portion further comprises a valve member that seals the hub portion.

12. The introducer sheath of claim 11, wherein the valve member further comprises
25 an elastomeric body having at least one slit formed therein to allow selective insertion and removal of a medical device while maintaining a fluid tight seal around the medical device.

13. The introducer sheath of claim 10, wherein the fluid port comprises an alignment
30 mechanism that aligns a medical device introduced through the sheath.

14. The introducer sheath of claim 9, wherein said distal end of said hub portion includes a transition from said distal end of said hub portion to said proximal end of at

least one of said tubular inner portion and said tubular outer portion, the introducer sheath further comprising a strain relief at said transition.

15. The introducer sheath of claim 11, wherein said tubular portion further comprises
5 a tapered end formed at said distal end of said tubular member.

16. A method for manufacturing an introducer sheath, the method comprising:
forming an inner portion of a tubular portion, the tubular portion extending
between a proximal end and a distal end, the inner portion defining a lumen; and
10 forming an outer portion around the inner portion, the outer portion enclosing less
than the entirety of the outer surface of the inner portion between the proximal end and
the distal end.

17. The method of claim 16, wherein the first material includes expandable PTFE.
15

18. The method of claim 16, further comprising forming a hub portion having a lumen
formed therein extending from at least one of said tubular inner portion and said tubular
outer portion.

20 19. The method of claim 18, wherein forming the inner portion, the outer portion, the
hub portion, or combinations thereof further comprises using one of an injection molding
process, an overmolding process, an extrusion process, a co-extrusion process, and a
bump extrusion process.

25 20. The method of claim 18, wherein the hub portion and at least one of the tubular
inner portion and the tubular outer portion are formed as a unitary member.

21. A method for performing a medical procedure, the method comprising:
introducing a sheath into a lumen of a patient, the sheath having a first unexpanded dimension;
inserting a first medical device having an outer dimension into the lumen through
5 the sheath to perform a medical procedure, wherein at least a tubular member of the sheath expands to a second expanded dimension to accommodate the outer dimension of the first medical device.
22. The method of claim 21, further comprising inserting a second medical device
10 through the sheath.
23. The method of claim 22, wherein inserting a second medical device through the sheath further comprises:
introducing a vessel closure device through the sheath; and
15 closing the lumen of the patient with the vessel closure device.
24. The method of claim 21, wherein the sheath comprises a tubular portion extending from the hub portion, the tubular portion comprising at least one elastic portion elastically deformable to increase a cross sectional area of the tubular portion.

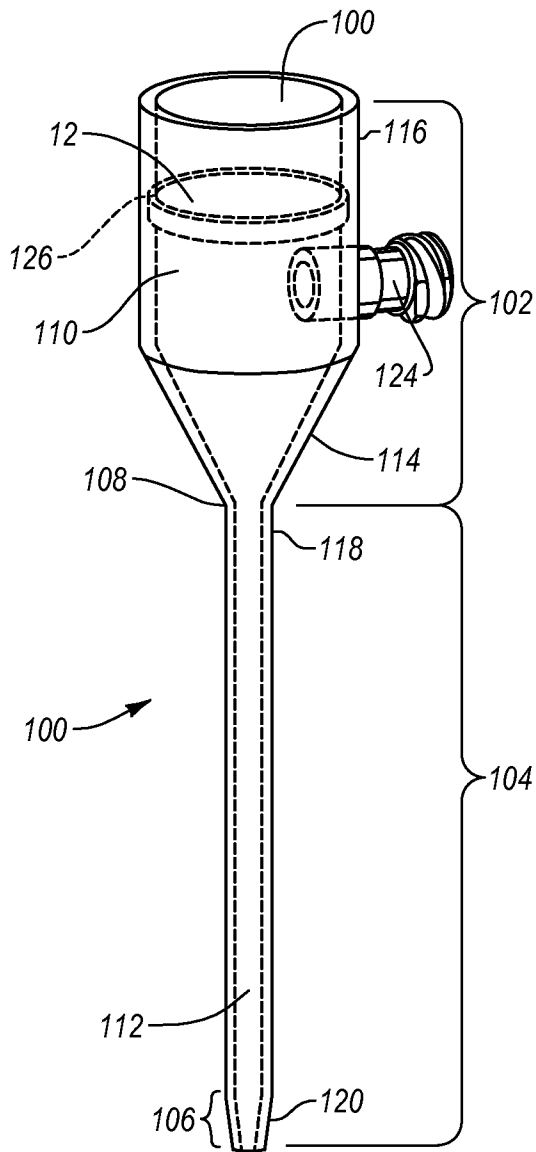

Fig. 1

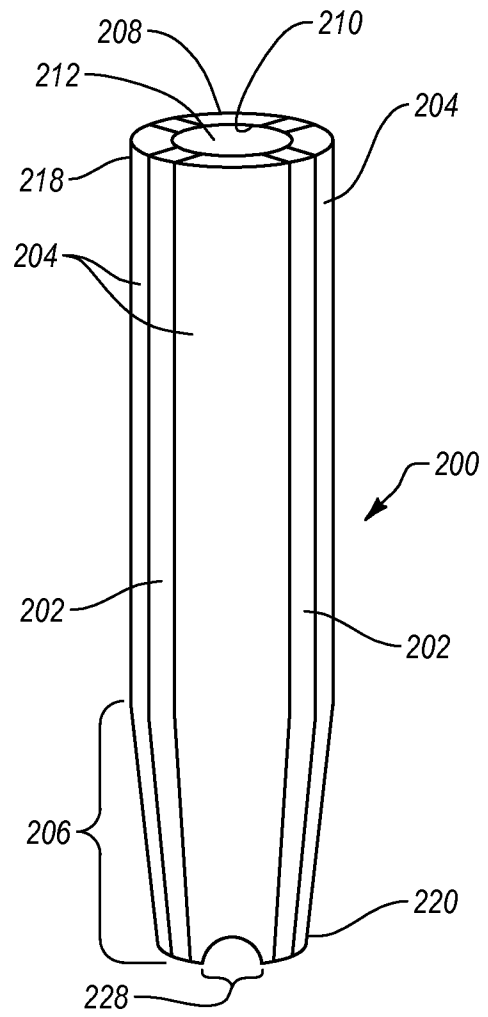

Fig. 2

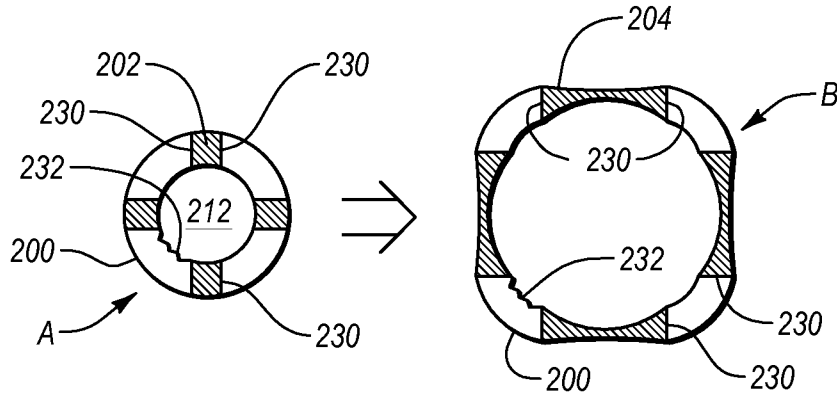

Fig. 3

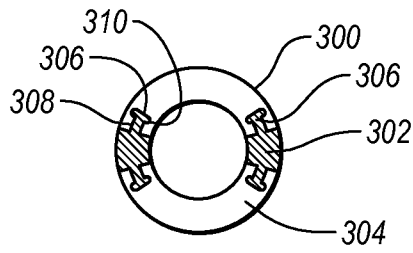

Fig. 4

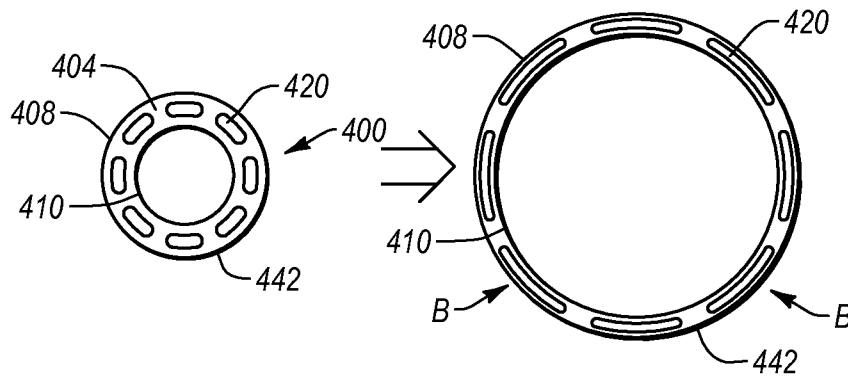

Fig. 5

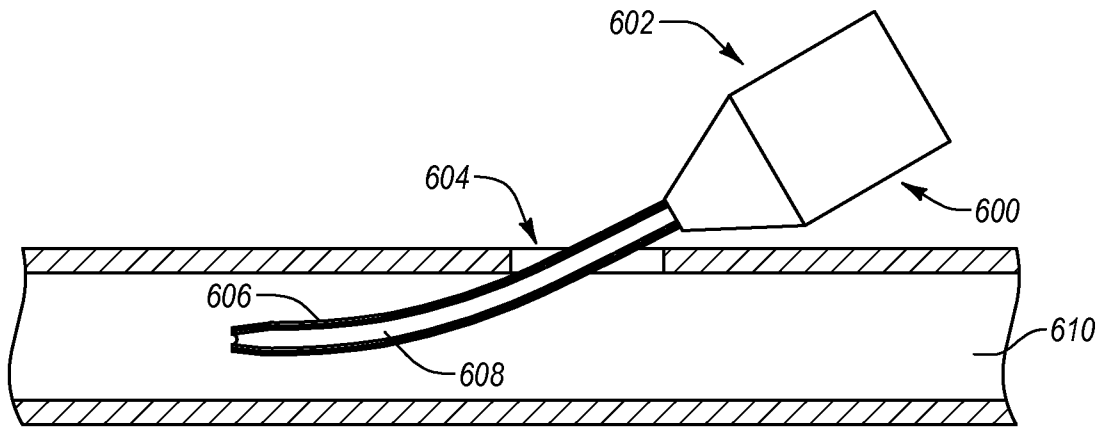

Fig. 6A

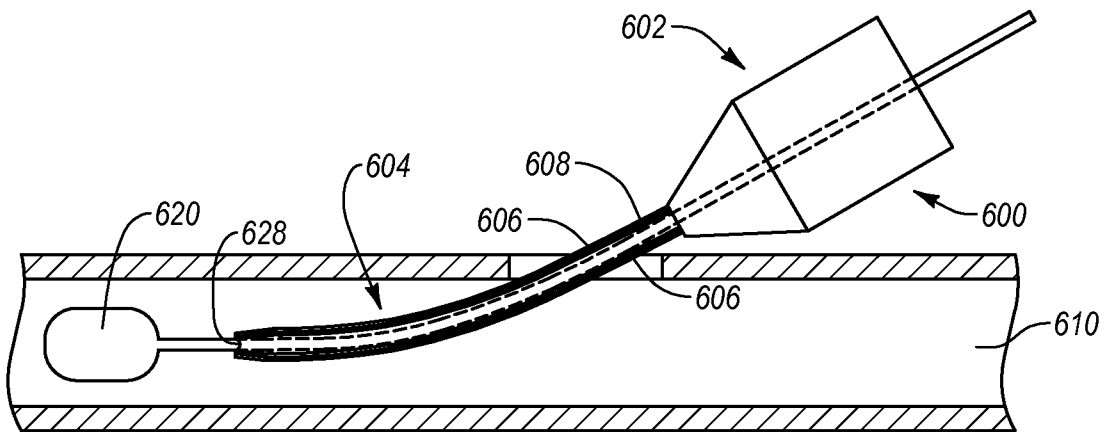

Fig. 6B

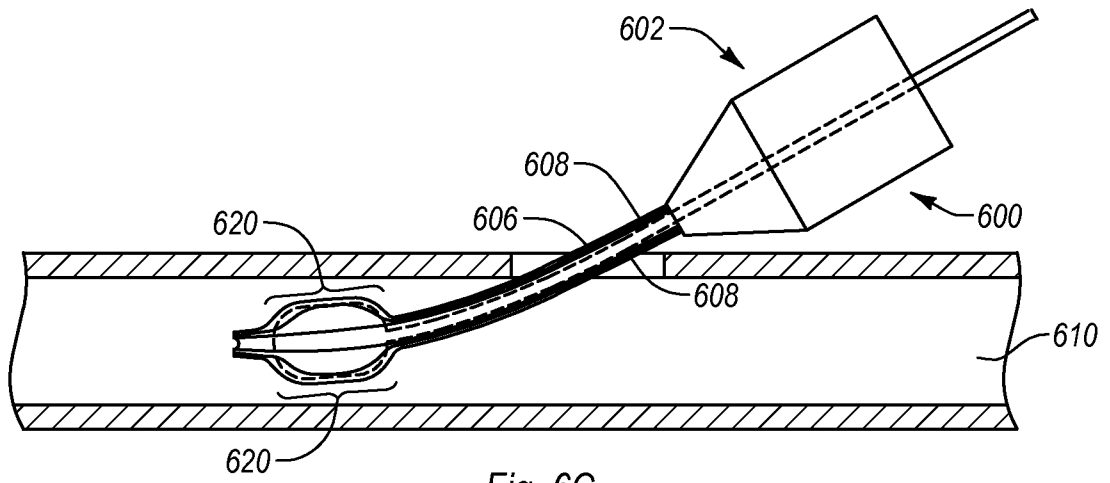

Fig. 6C

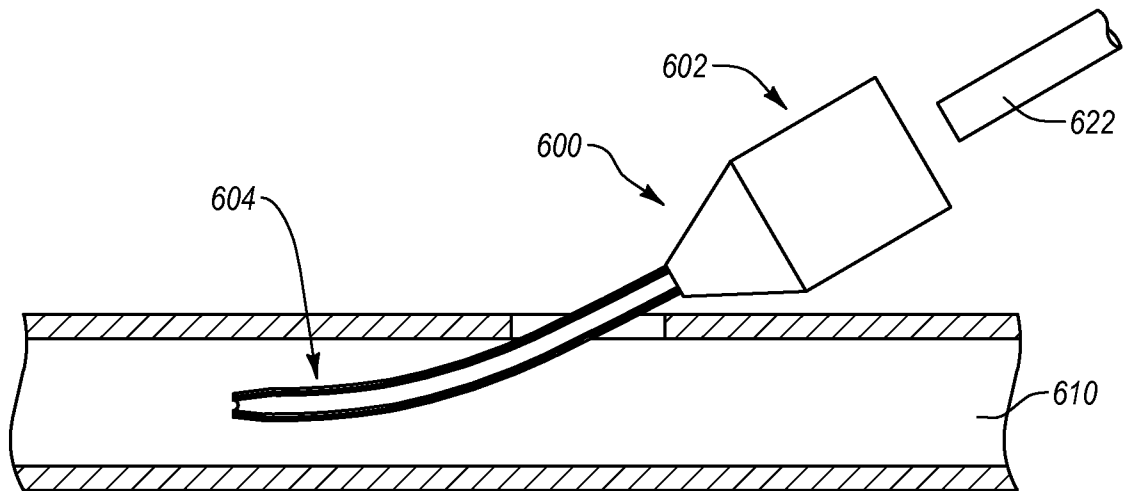
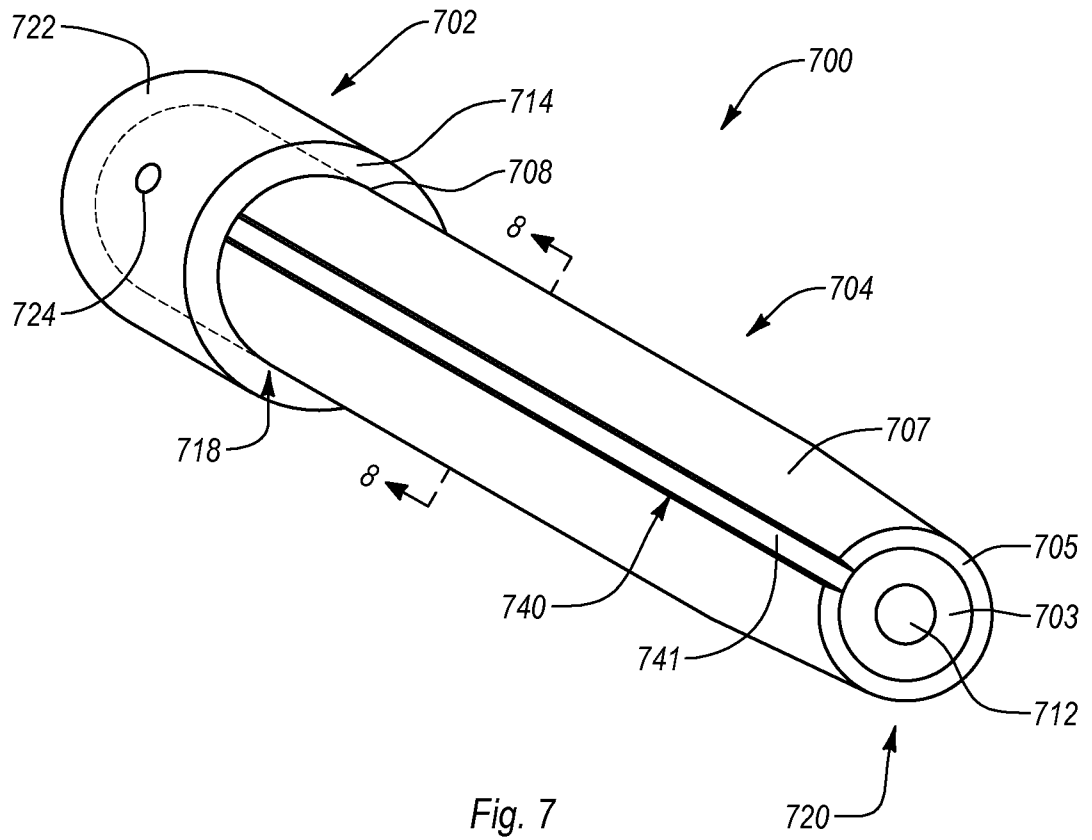

Fig. 6D



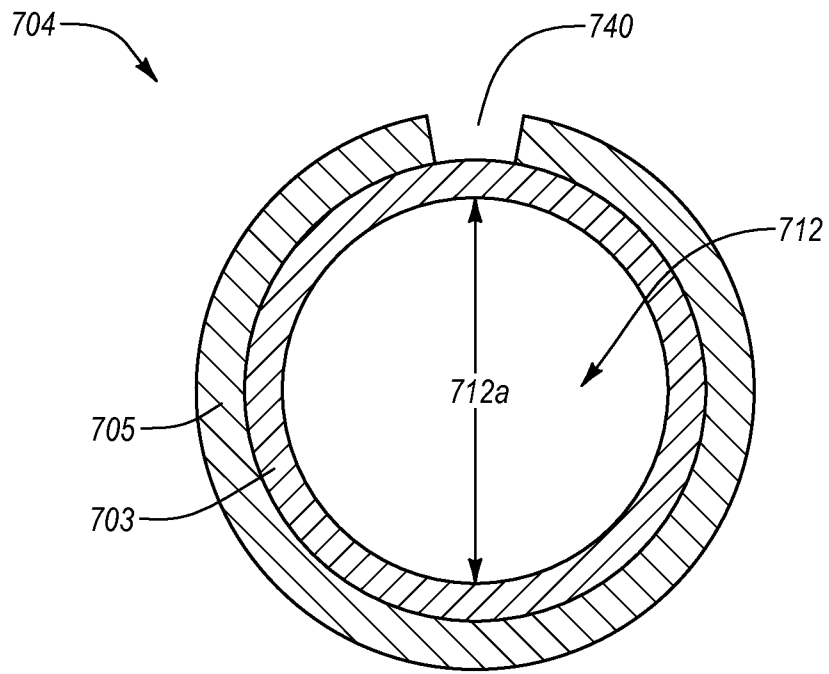

Fig. 8

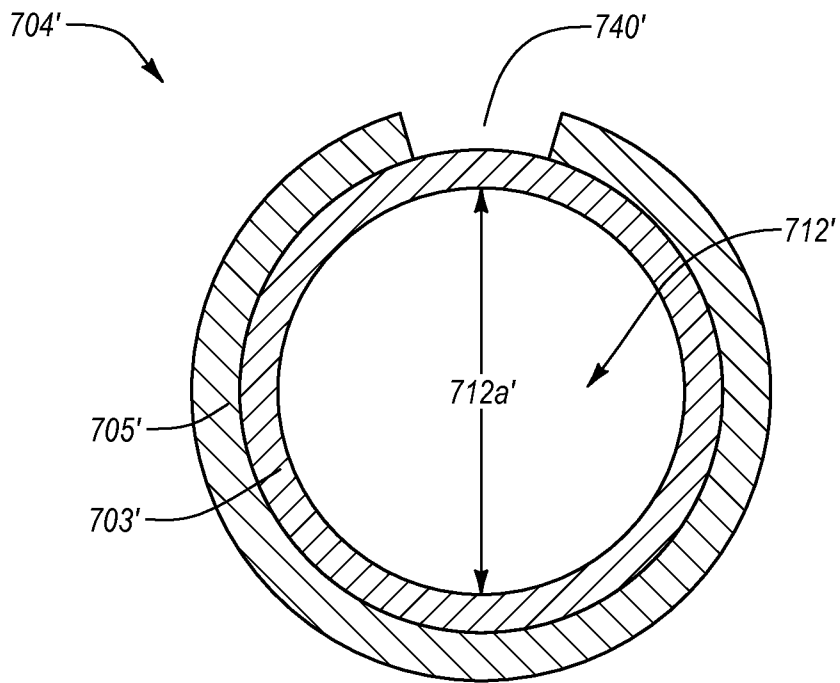

Fig. 9

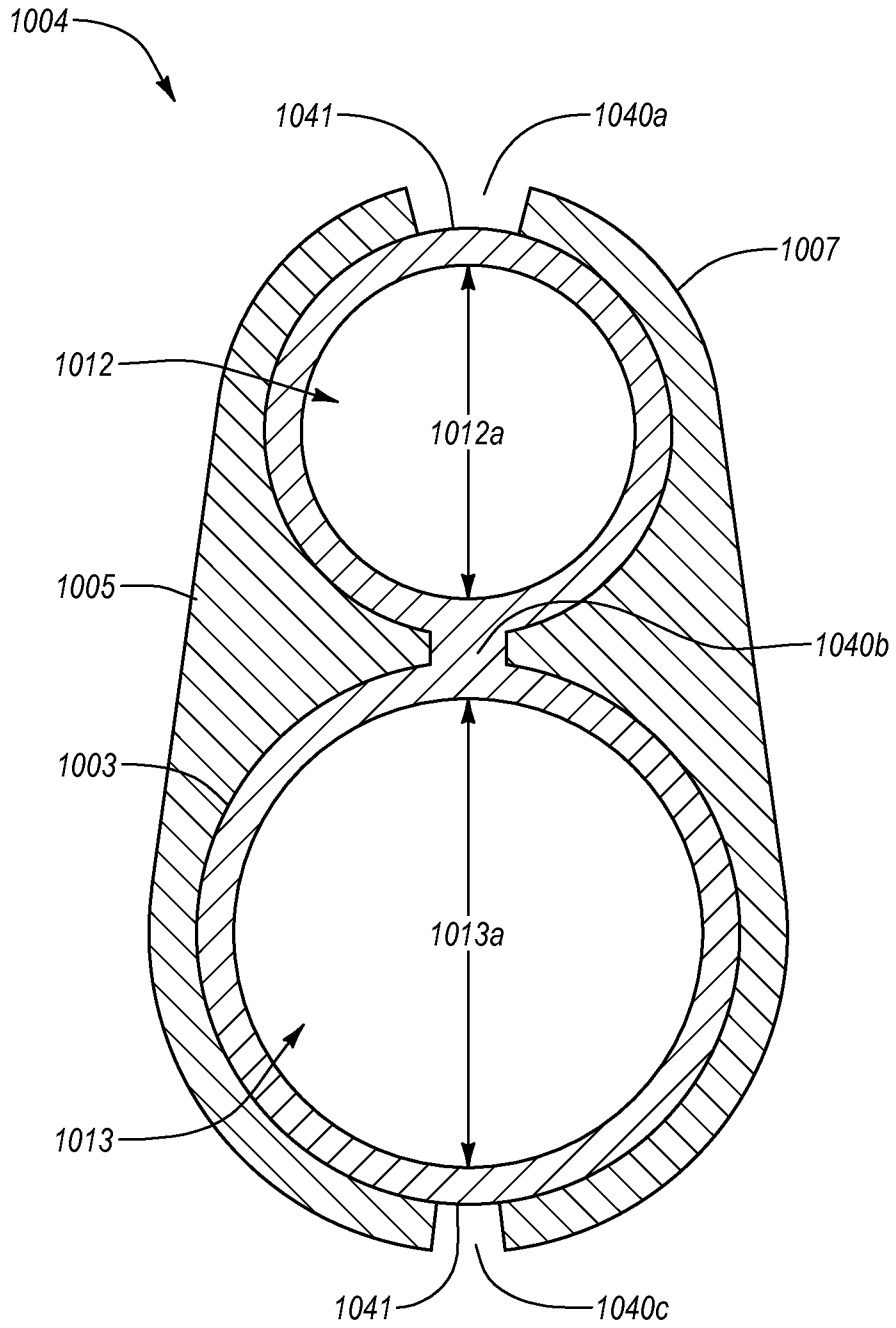

Fig. 10

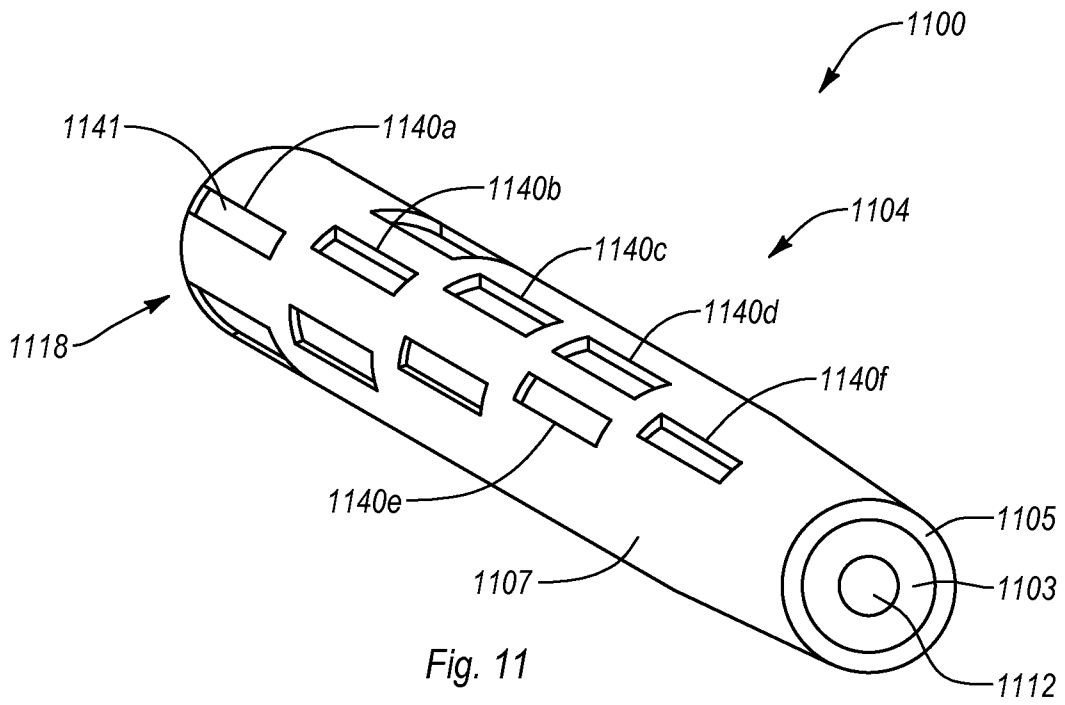

Fig. 11

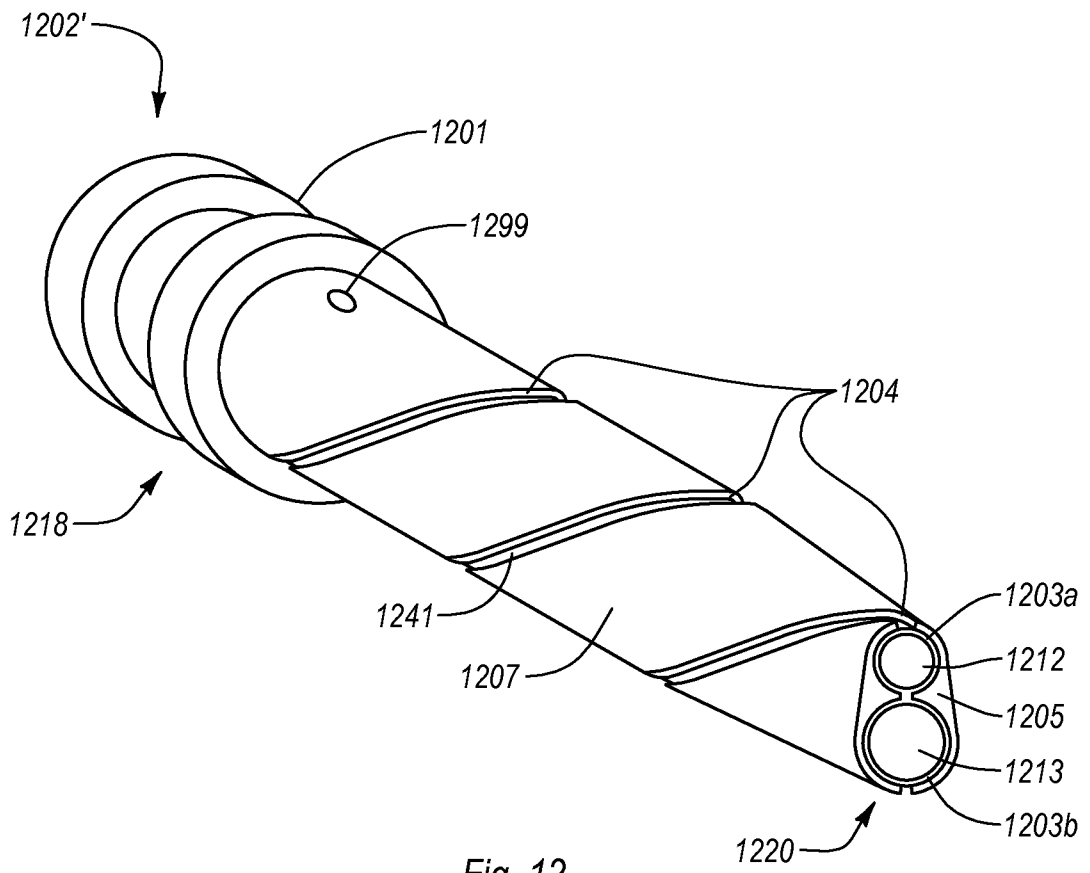

Fig. 12

INTERNATIONAL SEARCH REPORT

International application No
PCT/US2011/022768

A. CLASSIFICATION OF SUBJECT MATTER
INV. A61M25/00 A61M25/06 A61M39/22 A61B17/34
ADD.
According to International Patent Classification (IPC) or to both national classification and IPC

B. FIELDS SEARCHED
Minimum documentation searched (classification system followed by classification symbols)
A61M A61B

Documentation searched other than minimum documentation to the extent that such documents are included in the fields searched

Electronic data base consulted during the international search (name of data base and, where practical, search terms used)
EPO-Internal, WPI Data

C. DOCUMENTS CONSIDERED TO BE RELEVANT

Category*	Citation of document, with indication, where appropriate, of the relevant passages	Relevant to claim No.
X A	US 5 749 889 A (BACICH STEVEN R [US] ET AL) 12 May 1998 (1998-05-12) figures 1-4, 7 column 1, line 5 - line 10 column 11, line 4 - line 20 column 11, line 58 - column 13, line 25 -----	1-5, 16-20 6
A	WO 2004/037333 A1 (NMT MEDICAL INC [US]; CORE LEE A [US]) 6 May 2004 (2004-05-06) the whole document -----	1-6, 16-20
A	WO 2005/018728 A2 (NMT MEDICAL INC [US]; WRIGHT JOHN A JR [US]; PEAVEY TODD A [US]; KOLBE) 3 March 2005 (2005-03-03) the whole document -----	1-6, 16-20
	-/--	

Further documents are listed in the continuation of Box C.

See patent family annex.

* Special categories of cited documents :

"A" document defining the general state of the art which is not considered to be of particular relevance

"E" earlier document but published on or after the international filing date

"L" document which may throw doubts on priority claim(s) or which is cited to establish the publication date of another citation or other special reason (as specified)

"O" document referring to an oral disclosure, use, exhibition or other means

"P" document published prior to the international filing date but later than the priority date claimed

"T" later document published after the international filing date or priority date and not in conflict with the application but cited to understand the principle or theory underlying the invention

"X" document of particular relevance; the claimed invention cannot be considered novel or cannot be considered to involve an inventive step when the document is taken alone

"Y" document of particular relevance; the claimed invention cannot be considered to involve an inventive step when the document is combined with one or more other such documents, such combination being obvious to a person skilled in the art.

"&" document member of the same patent family

Date of the actual completion of the international search 25 March 2011	Date of mailing of the international search report 14/06/2011
--	--

Name and mailing address of the ISA/ European Patent Office, P.B. 5818 Patentlaan 2 NL - 2280 HV Rijswijk Tel. (+31-70) 340-2040, Fax: (+31-70) 340-3016	Authorized officer Przykutta, Andreas
--	--

INTERNATIONAL SEARCH REPORT

International application No.
PCT/US2011/022768

Box No. II Observations where certain claims were found unsearchable (Continuation of item 2 of first sheet)

This international search report has not been established in respect of certain claims under Article 17(2)(a) for the following reasons:

1. Claims Nos.: 21-24
because they relate to subject matter not required to be searched by this Authority, namely:
Rule 39.1(iv) PCT - Method for treatment of the human or animal body by surgery
2. Claims Nos.:
because they relate to parts of the international application that do not comply with the prescribed requirements to such an extent that no meaningful international search can be carried out, specifically:
3. Claims Nos.:
because they are dependent claims and are not drafted in accordance with the second and third sentences of Rule 6.4(a).

Box No. III Observations where unity of invention is lacking (Continuation of item 3 of first sheet)

This International Searching Authority found multiple inventions in this international application, as follows:

see additional sheet

1. As all required additional search fees were timely paid by the applicant, this international search report covers all searchable claims.
2. As all searchable claims could be searched without effort justifying an additional fees, this Authority did not invite payment of additional fees.
3. As only some of the required additional search fees were timely paid by the applicant, this international search report covers only those claims for which fees were paid, specifically claims Nos.:
4. No required additional search fees were timely paid by the applicant. Consequently, this international search report is restricted to the invention first mentioned in the claims; it is covered by claims Nos.:

see annex

Remark on Protest

- The additional search fees were accompanied by the applicant's protest and, where applicable, the payment of a protest fee.
- The additional search fees were accompanied by the applicant's protest but the applicable protest fee was not paid within the time limit specified in the invitation.
- No protest accompanied the payment of additional search fees.

INTERNATIONAL SEARCH REPORT

International application No
PCT/US2011/022768

C(Continuation). DOCUMENTS CONSIDERED TO BE RELEVANT		
Category*	Citation of document, with indication, where appropriate, of the relevant passages	Relevant to claim No.
A	WO 2007/005584 A1 (ABBOTT LAB [US]; VOSS LAVEILLE KAO [US]; ROWE DOUGLAS [US]; MCINTOSH S) 11 January 2007 (2007-01-11) the whole document	1-6, 16-20
A	----- US 2009/221965 A1 (OSYPKA PETER [DE]) 3 September 2009 (2009-09-03) the whole document -----	1-6, 16-20

INTERNATIONAL SEARCH REPORT

Information on patent family members

International application No PCT/US2011/022768

Patent document cited in search report	Publication date	Patent family member(s)	Publication date
US 5749889	A	12-05-1998	NONE

WO 2004037333	A1	06-05-2004	AU 2003284976 A1 13-05-2004
			EP 1556117 A1 27-07-2005
			US 2004087968 A1 06-05-2004

WO 2005018728	A2	03-03-2005	AT 413898 T 15-11-2008
			CA 2536368 A1 03-03-2005
			EP 1660167 A2 31-05-2006
			US 2005080430 A1 14-04-2005

WO 2007005584	A1	11-01-2007	EP 1931412 A1 18-06-2008

US 2009221965	A1	03-09-2009	DE 102008011688 A1 10-09-2009

FURTHER INFORMATION CONTINUED FROM PCT/ISA/ 210

This International Searching Authority found multiple (groups of) inventions in this international application, as follows:

1. claims: 1-6, 16-20

An introducer sheath comprising:
a tubular portion extending from said hub portion, said tubular portion including:
an inner portion forming a lumen extending from a distal end toward a proximal end; and
an outer portion disposed partially around said inner portion, said outer portion extending from said distal end toward said proximal end, at least a portion of said inner portion being exposed between said proximal end and said distal end,
wherein said outer surface of said outer portion includes at least one aperture between said proximal end and said distal end,
wherein said outer surface of said outer portion includes a plurality of apertures oriented between said proximal end and said distal end.

2. claims: 7-15

An introducer sheath comprising:
a tubular portion extending between a proximal end and a distal end, said tubular portion including:
an inner portion forming a first lumen and a second lumen;
and
an outer portion disposed partially around said inner portion, said inner portion and said outer portion extending between said proximal end and said distal end, at least a portion of said inner portion being exposed between said proximal end and said distal end.
