



(22) Date de dépôt/Filing Date: 2012/08/31  
(41) Mise à la disp. pub./Open to Public Insp.: 2013/03/01  
(30) Priorité/Priority: 2011/09/01 (US61/530,041)

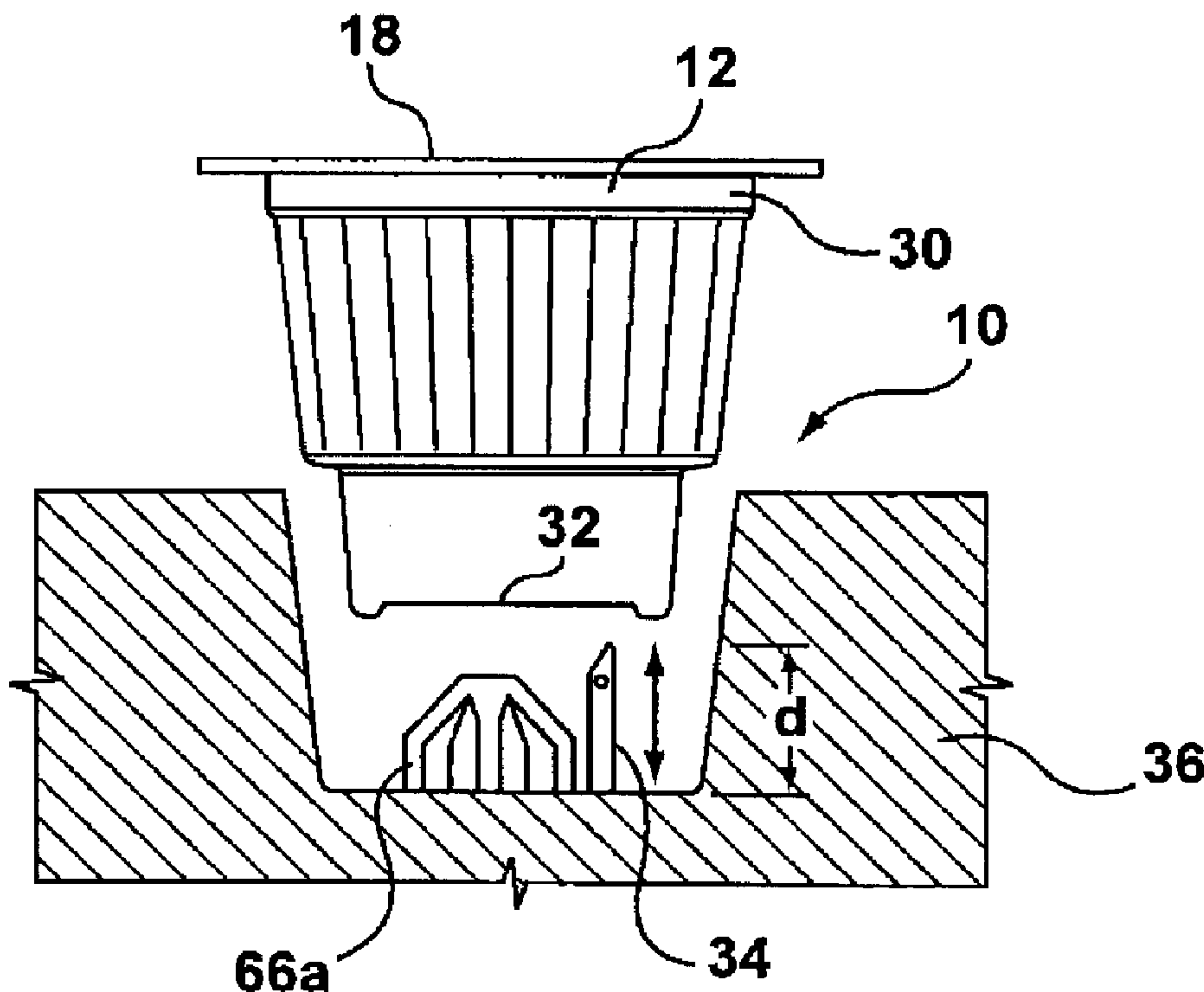
(51) Cl.Int./Int.Cl. *B65D 85/804* (2006.01),  
*A47J 31/06* (2006.01), *A47J 31/10* (2006.01),  
*B65D 85/816* (2006.01)

(71) Demandeur/Applicant:  
2266170 ONTARIO INC., CA

(72) Inventeurs/Inventors:  
TROMBETTA, LIBERATORE A., CA;  
FU, YUCHENG, CA;  
PAYNTER, DENNIS DWIGHT, US;  
KHAN, DAUD, CA;  
MEFFEN, CHRISTOPHER DOUGLAS, CA;  
HANNESON, SCOTT, CA

(74) Agent: BERESKIN & PARR LLP/S.E.N.C.R.L.,S.R.L.

(54) Titre : CAPSULE DE CONTENANT DE BOISSON  
(54) Title: BEVERAGE CAPSULE



(57) **Abrégé/Abstract:**

A beverage capsule is provided having a body, a filter disposed in the body, ingredients disposed in the filter and a cover. The body includes a side wall that extends from an end wall to an opening that is covered by the cover. A boss extends into the interior space from the end wall inwardly of an extraction region. In one embodiment, the boss defines an engagement surface having a plurality of arms adapted for engaging a bottom portion of the filter during use. In another embodiment, the boss engages the filter to define a tented filter zone wherein an inner portion of the filter is spaced a further distance from the end wall than an outer portion of the filter. In another embodiment, a diffusing surface is disposed in the body downstream of where a fluid is intended to enter the opening of the capsule during use with a beverage preparing machine, the diffusing surface being adapted to redirect fluid that engages the diffusing surface to desired locations within the capsule.

## ABSTRACT

A beverage capsule is provided having a body, a filter disposed in the body, ingredients disposed in the filter and a cover. The body includes a side wall that extends from an end wall to an opening that is covered by the cover. A boss extends into the interior space from the end wall inwardly of an extraction region. In one embodiment, the boss defines an engagement surface having a plurality of arms adapted for engaging a bottom portion of the filter during use. In another embodiment, the boss engages the filter to define a tented filter zone wherein an inner portion of the filter is spaced a further distance from the end wall than an outer portion of the filter. In another embodiment, a diffusing surface is disposed in the body downstream of where a fluid is intended to enter the opening of the capsule during use with a beverage preparing machine, the diffusing surface being adapted to redirect fluid that engages the diffusing surface to desired locations within the capsule.

**TITLE: BEVERAGE CAPSULE****FIELD**

[0001] This specification relates to beverage capsules and in particular to beverage capsules adapted for use with beverage preparing machines.

**BACKGROUND**

[0002] The following background discussion is not an admission that anything discussed below is citable as prior art or common general knowledge. The documents listed below are incorporated herein in their entirety by this reference to them.

[0003] Beverage capsules containing filters and ingredients for use with beverage preparing machines are well known. A fluid, such as hot water, is injected into the beverage capsule using the beverage preparing machine in order that the fluid may mix with the ingredients to form a desired beverage. The desired beverage then flows through the filter and exits the capsule through an opening that is formed in the capsule downstream of the filter.

[0004] One problem with such capsules is that the flow of fluid through the filter may be slowed or impeded by fines that collect in the filter. The fines comprise small particles of ingredients that may block some or all of the pores or openings of the filter.

[0005] Another problem with such capsules is that the flow of fluid injected into the capsule may be concentrated along a particular path (such as the central axis of the capsule where the fluid is injected) with the result that the fluid does not sufficiently saturate all of the ingredients contained within the capsule.

[0006] There is a need for an improved beverage capsule that addresses the above problems or that otherwise provides advantages over conventional capsules.

**SUMMARY**

[0007] In one aspect the invention provides a beverage capsule intended for use in a beverage preparing machine, said beverage capsule comprising:

a body having a side wall extending from an end wall to an opening to define an interior space, said end wall including an extraction region that is adapted to be pierced to facilitate flow of beverage from said capsule;

a filter disposed in said body to define an ingredients chamber, located between said opening and said filter, and an extraction chamber located between said filter and said end wall;

a boss extending from said end wall into said interior space, said boss defining an engagement surface having a plurality of arms for engaging a bottom surface of said filter during use;

one or more ingredients disposed in said ingredients chamber for preparing a desired beverage; and

a cover for covering said opening.

[0008] In another aspect the invention provides a beverage capsule intended for use in a beverage preparing machine, said beverage capsule comprising:

a body having a sidewall extending from an end wall to an opening; and

a filter disposed in said body, said filter having an inner portion and an outer portion where the inner portion is spaced a greater distance from said end wall than the distance said outer portion is spaced from said end wall.

[0009] In another aspect the invention provides a beverage capsule intended for use in a beverage preparing machine, said beverage capsule comprising:

a body having a side wall extending from an end wall to an opening;

a diffusing surface disposed in said body downstream of where a fluid is intended to enter the opening of said capsule during use with a beverage preparing

machine, said diffusing surface being adapted to redirect fluid that engages said diffusing surface to desired locations within said capsule.

[0010] In another aspect the invention provides a beverage capsule intended for use in a beverage preparing machine, said beverage capsule comprising:

a body having a side wall extending from an end wall to an opening to define an interior space, said end wall including an extraction region that is adapted to be pierced to facilitate flow of beverage from said capsule;

a filter disposed in said body to define an ingredients chamber, located between said opening and said filter, and an extraction chamber located between said filter and said end wall;

a boss extending from said end wall into said interior space, said boss engaging said filter to define a tented filter zone wherein an inner portion of said filter is spaced a further distance from said end wall than an outer portion of said filter;

one or more ingredients disposed in said ingredients chamber for preparing a desired beverage; and

a cover for covering said opening..

[0011] Other aspects and features of the teachings disclosed herein will become apparent, to those ordinarily skilled in the art, upon review of the following description of the specific examples of the specification.

#### **DRAWINGS**

[0012] The drawings included herewith are for illustrating various examples of articles, methods, and apparatuses of the present specification and are not intended to limit the scope of what is taught in any way. For simplicity and clarity of illustration, where considered appropriate, reference numerals may be repeated among the drawings to indicate corresponding or analogous elements.

[0013] Figure 1 is front view of a beverage capsule in accordance with the present invention;

[0014] Figure 2 is a top view of a body of a beverage capsule in accordance with the present invention;

[0015] Figure 3 is a sectional view of the body shown in Figure 2 as viewed along lines 3-3;

[0016] Figure 4 is an enlarged perspective view of the boss for the body shown in Figure 2;

[0017] Figure 5 is a top view of the filter bottom for the beverage capsule of Figure 1 showing the distribution of fines following use;

[0018] Figure 6 is a sectional view of the filter bottom of Figure 5 as viewed along lines 6-6;

[0019] Figure 7 is an exploded sectional view of a beverage capsule in accordance with one embodiment of the present invention;

[0020] Figure 8 is an exploded sectional view of a beverage capsule in accordance with another embodiment of the present invention;

[0021] Figure 9 is an exploded sectional view of a beverage capsule in accordance with another embodiment of the present invention;

[0022] Figure 10 is a top view of a filter support disc for a beverage capsule in accordance with another embodiment of the present invention;

[0023] Figure 11 is a side view of the filter support disc shown in Figure 10;

[0024] Figure 12 is front view of another embodiment of beverage capsule in accordance with the present invention;

[0025] Figure 13 is a top view of a body of another embodiment of beverage capsule in accordance with the present invention;

[0026] Figure 14 is a sectional view of the body shown in Figure 13 as viewed along lines 14-14;

[0027] Figure 15 is an exploded sectional view of a beverage capsule in accordance with another embodiment of the present invention;

[0028] Figure 16 is an exploded sectional view of a beverage capsule in accordance with another embodiment of the present invention;

[0029] Figure 17 is a top view of the filter as formed for the beverage capsule shown in figure 16 showing the inner portion and outer portion of filter;

[0030] Figure 18 is a perspective view of a boss element adapted to rest on the end wall of a beverage capsule in accordance with another embodiment of the present invention;

[0031] Figure 19 is a perspective view of a diffusing element adapted to rest on the flange of a beverage capsule in accordance with another embodiment of the present invention.

#### **DESCRIPTION OF VARIOUS EMBODIMENTS**

[0032] Various apparatuses or methods will be described below to provide examples of the claimed invention. The claimed invention is not limited to apparatuses or methods having all of the features of any one apparatus or method described below or to features common to multiple or all of the apparatuses described below. The claimed invention may reside in a combination or sub-combination of the apparatus elements or method steps described below. It is possible that an apparatus or method described below is not an example of the claimed invention. The applicant(s), inventor(s) and/or owner(s) reserve all rights in any invention disclosed in an apparatus or method described below that is not claimed in this document and do not abandon, disclaim or dedicate to the public any such invention by its disclosure in this document.

[0033] A beverage capsule in accordance with the present invention is shown generally at 10 in the Figures. Beverage capsule 10 includes a body 12, filter 14, ingredients 16 and cover 18.

[0034] Body 12 includes a side wall 20 and an end wall 22 together defining an interior space 24. An opening 26 is defined at one end of body 12. A flange 28 extends around the perimeter of opening 26 and a stacking ring 30 (if required) is defined in side wall 20 below flange 28.

[0035] End wall 22 includes an extraction region 32 adapted for being pierced by an extraction needle 34 of a beverage preparing machine 36. Extraction needle 34 is adapted to extend a maximum distance  $d$  into body 12 from end wall 22.

[0036] As shown in Figures 7-9, filter 14 is adapted to be disposed within body 12 to define at least one ingredients chamber 46 in an upper region of said interior space for receiving one or more ingredients and at least one extraction chamber 48 in a lower region of said interior space for receiving beverage from said at least one ingredients chamber 46 prior to extraction using said extraction needle 34. Filter 14 includes a bottom portion 44 that is preferably disposed a distance  $D$  from end wall 22 that is sufficient to prevent filter 14 from being pierced or torn by extraction needle 34 during use.

[0037] Ingredients 16 may be coffee grounds, tea leaves, chocolate powder, milk powder, instant coffee or any other ingredients or combinations of ingredients that may be used to prepare a beverage in a beverage preparing machine 36 as described herein. Ingredients 16 have a desired particle size range however it is common for fines 16a (particles much smaller than the desired range), to be present in ingredients 16. In conventional capsules, fines 16a tend to collect at the lowest most regions of the filter 14 and may block the pores of the filter 14 to such an extent as to slow down or stop the flow of beverage through the filter 14.

[0038] Filter 14 may be formed of any food grade filter material suitable for filtering the ingredients under the conditions of use for the beverage preparing machine. Paper or synthetic filter materials (polymers or biopolymers) are preferred with non-woven filter materials being most preferred.

[0039] Body 12 includes a boss 50 that extends into interior space 24 from end wall 22 inwardly of extraction region 32. Boss 50 is preferably integrally formed with end wall 22 but may alternatively be formed as a separate piece that is supported within body 12 as shown in Figures 10 and 11.

[0040] Referring to Figure 4, boss 50 includes a side wall 52 that slopes upwardly and inwardly from end wall 22 to an engagement surface 54.



Engagement surface 54 is adapted to engage bottom portion 44 of filter 14 when filter 14 becomes saturated during use of beverage capsule 10. Preferably, engagement surface 54 is disposed at the same distance from end wall 22 as the bottom portion of filter 14 plus or minus a few millimeters.

[0041] Preferably engagement surface 54 is relatively flat and extends generally parallel to end wall 22. However, engagement surface 54 may instead be dimpled, scored or otherwise profiled. Also, engagement surface 54 may extend at an incline or a curve relative to end wall 22.

[0042] Engagement surface 54 includes a plurality of arms 56 that define voids 58 between respective arms 56. Boss 50 preferably is a frustum that is star shaped in cross section or top view as shown in Figure 2. Other cross sectional shapes may also be suitable including cross shapes or triangular shapes provided that at least one void 58 is defined between arms 56.

[0043] Referring to Figures 5 and 6, when filter 14 and ingredients 16 become saturated during use of beverage capsule 10 in beverage preparing machine 36, bottom portion 44 sags onto engagement surface 54 over arms 56 and at least partially into voids 58. As a result, a series of peaks 60, valleys 62 and slopes 64 are formed in bottom portion 44. As fluid is introduced into capsule 10 centrally through cover 18, fluid tends to form eddies and carry fines 16a to the peripheral regions of filter 14. Fines 16a tend to settle and collect within valleys 62 particularly at the periphery of bottom portion 44. This ensures that the remainder of bottom portion 44 is sufficiently clear of fines 16a to allow beverage to flow at a desired rate.

[0044] In addition to providing collection zones in valleys 62 for fines 16a, it is believed that contact between bottom portion 44 of filter 14 and engagement surface 54 of boss 50 encourages fluid flow through filter 14 in a similar manner as contact between one's finger and the walls of a tent encourages flow of water through the tent wall. It is believed that the plurality of arms 56 and voids 58 aid in increasing the surface tension at bottom portion 44 of filter 14 as filter 14 becomes saturated during use. The increased surface tension further opens the pores of filter 14 to encourage fluid flow particularly at the location of voids 58.

[0045] Boss 50 preferably defines a corresponding recess 66 on outer surface of end wall 22 that may be adapted to fit with a corresponding shaped key 66a extending from the beverage preparing machine 36. The recess 66 aids in aligning capsule 10 in a desired orientation within beverage preparing machine 36 and also provides an opportunity for capsules 12 to be adapted for use only with machines 36 having corresponding keys 66a.

[0046] Body 12 may also include channels 68 defined in side wall 14 between upper and lower regions of the interior space of capsule 10 to facilitate air and fluid flow between the regions. Channels 68 may be defined between ribs 70 that provide additional rigidity to side wall 14. The added rigidity of ribs 70 allows capsule 10 to be better suited to withstand forces associated with manufacturing, handling, and brewing. Channels 68 and ribs 70 are optional elements however and side wall 14 of body 12 may have other configurations including the flat sided configuration seen with conventional beverage capsules.

[0047] Referring to one embodiment of capsule 10 as shown in Figure 7, filter 14 is generally cylindrical in shape with a filter side wall 80 and filter bottom 82. Filter 14 also includes a gasket 84, preferably integrally formed with filter 14, for securing filter 14 to flange 28 of body 12 to support filter 14 within capsule 10. Gasket 84 may be formed of a material having a higher melt temperature than flange 28 and cover 18 to allow the elements to be heat sealed together. Alternatively, flange 28 may be larger in diameter than gasket 84 (as shown in Figure 2) in order to define a first region 86 for securing filter 14 to flange 28 and a second region 88 located radially outwards from first region 86 for securing cover 18 to flange 28.

[0048] Referring to another embodiment of capsule 10 as shown in Figure 8, filter 14 has a peripheral edge 88 (instead of gasket 84) that is secured to an attachment surface 90 defined on side wall 14 at an upper inside portion of body 12 such as at stacking ring 30.

[0049] Referring to another embodiment of capsule 10 as shown in Figure 9, filter 14 is generally disc shaped and has a peripheral edge 92 secured to a ledge 94 defined on side wall 14 of body 12.

[0050] Referring to Figures 10 and 11, a filter support disc 96 is shown. Filter support disc 96 is adapted to be supported on ledge 94 of body for supporting a filter 14. Filter support disc 96 includes a ring 98 that is sized to be secured to ledge 94. Spokes 100 extend inwardly from ring 98 to support engagement surface 54. Engagement surface 54 acts in a similar manner as described above to engage a bottom portion of filter 14 to encourage flow of fluid there through. Spokes 100 may extend at an incline (as shown in Figure 11) if necessary to support engagement surface 54 at a desired level so as to engage bottom portion 44 of filter 14 once it becomes saturated. Preferably, engagement surface 54 is disposed at the same distance from end wall 22 as the bottom portion of filter 14 plus or minus a few millimeters

[0051] Referring to Figures 12 to 19, other embodiments of beverage capsule are shown. The same reference numerals are used to refer to similar elements as described above.

[0052] Body 12 includes a boss 200 that extends into interior space 24 from end wall 22 inwardly of extraction region 32. Boss 200 is preferably integrally formed with end wall 22 but may alternatively be formed as a separate element that is supported within body 12 as shown in Figure 18. Boss 200 preferably is shaped as a frustum and most preferably is frustoconical or polygonal.

[0053] Referring to Figures 15 and 16, boss 200 includes a side wall 202 that slopes upwardly and inwardly from end wall 22 to a tip 204. Boss 200 is adapted to support a portion of filter 14 to define a tented filter zone 206 within interior space 24. Tented filter zone 206 includes a raised inner portion 208 of filter 14 that is spaced a greater distance from end wall 22 than a lower outer portion 210 of filter 14.

[0054] As fluid is introduced into capsule 10 centrally through cover 18, fluid tends to form eddies and carry fines 16a to the peripheral regions of bottom portion of filter 14. Fines 16a tend to settle and collect at the lower outer portion 210 of filter 14. Tented filter zone 206 includes an inclined filter wall 212 that ensures that the remainder of bottom portion 44 is sufficiently clear of fines 16a to allow beverage to flow at a desired rate.

[0055] Tip 204 preferably defines a diffusing surface 220 to engage and diffuse a laminar stream of fluid that enters capsule 10 for optimum saturation of ingredients within capsule 10. Diffusing surface 220 may be integrally formed with tip 204 or it may be disposed as a separate element within capsule 10 as shown in Figure 19. Diffusing surface 220 preferably is concave in shape but other suitable diffusing structures may be utilized.

[0056] For beverage preparing machines having a central nozzle that directs fluid in a laminar stream into the capsule 10, diffusing surface 220 is preferably sized to engage the entire stream of fluid without occupying more space than is necessary within capsule 10. Preferably, diffusing surface 220 has a cross-sectional area that is no greater than 20% of the cross-sectional area of interior space of capsule 10 as measured in a plane P in which diffusing surface 220 is located. It is also preferable that diffusing surface 220 is disposed at a height within capsule 10 that optimizes the saturation of ingredients within the capsule without occupying more space than is necessary within capsule. Preferably, diffusing surface 220 is spaced a distance H from opening that is no less than 20% and no more than 80% of the overall height of capsule 10 as measured from end wall 22 to opening 24.

[0057] Boss 200 preferably defines a recess 230 on an outer surface of end wall 22 that may be adapted to fit with a corresponding shaped key 232 extending from the beverage preparing machine 36. The recess 230 aids in aligning capsule 10 in a desired orientation within beverage preparing machine 36 and also provides an opportunity for capsules 12 to be adapted for use only with machines 36 having corresponding keys 232.

[0058] Referring to one embodiment of capsule 10 as shown in Figure 15, filter 14 includes a filter side wall 240 and filter bottom 242 having tented filter zone 206 defined therein. Filter 14 also includes a gasket 244 for securing filter 14 to flange 28 of body 12 to support filter 14 within capsule 10. Gasket 244 may be formed of a material having a higher melt temperature than flange 28 and cover 18 to allow the elements to be heat sealed together. Alternatively, flange 28 may be larger in diameter than gasket 244 (as shown in Figure 13) in order to define a

first region 246 for securing filter 14 to flange 28 and a second region 248 located radially outwards from first region 246 for securing cover 18 to flange 28.

[0059] Referring to another embodiment of capsule 10 as shown in Figure 16, filter 14 has a peripheral edge 250 secured to a ledge 252 defined on side wall 20 of body 12 with tented filter zone 206 defined in filter 14 inwardly of peripheral edge 250.

[0060] Referring to Figure 17, a top view of the filter 14 for the embodiment of capsule 10 in Figure 16 is shown. The figure shows the location where boss 200 engages bottom portion 44 of filter 14 to form tented filter zone 206 with raised inner portion 208 and lower outer portion 210.

[0061] Referring to Figure 18, a boss element 254 adapted for resting on end wall 22 is shown. Boss element 254 includes an annular footing 256, side ribs 258 and tip 204 defining diffusing surface 220. Boss element 254 is adapted for use in a standard cup-shaped body 12 instead of integrally molding a boss into end wall 22. Diffusing surface 220 preferably is concave in shape but other suitable diffusing structures may be utilized.

[0062] Referring to Figure 19, a diffusing element 260 adapted for resting on flange 28 of capsule 10 is shown. Diffusing element 260 includes an annular flange 262, side ribs 264 and diffusing surface 220. Diffusing element 260 is adapted for use in a body 12 of a capsule 10, such as a conventional beverage capsule, where diffusion of fluid to better saturate ingredients is desired and no boss 200 or boss element 254 is provided. Diffusing surface 220 preferably is concave in shape but other suitable diffusing structures may be utilized.

[0063] While the above description provides examples of one or more processes or apparatuses, it will be appreciated that other processes or apparatuses may be within the scope of the accompanying claims.

**CLAIMS**

I/We claim:

1. A beverage capsule intended for use in a beverage preparing machine, said beverage capsule comprising:

a body having a side wall extending from an end wall to an opening to define an interior space, said end wall including an extraction region that is adapted to be pierced to facilitate flow of beverage from said capsule;

a filter disposed in said body to define an ingredients chamber, located between said opening and said filter, and an extraction chamber located between said filter and said end wall;

a boss extending from said end wall into said interior space, said boss defining an engagement surface having a plurality of arms for engaging a bottom surface of said filter during use;

one or more ingredients disposed in said ingredients chamber for preparing a desired beverage; and

a cover for covering said opening.

2. The beverage capsule of claim 1, wherein said engagement surface is star shaped.

3. The beverage capsule of claim 1, further comprising a ledge defined on the side wall of said body for supporting said filter.

4. The beverage capsule of claim 1, wherein said boss includes a plurality of channels extending at least partially between said engagement surface and said end wall.

5. The beverage capsule of claim 1, wherein said side wall of said body defines a plurality of channels extending at least partially between said extraction chamber and said opening.

6. A beverage capsule intended for use in a beverage preparing machine, said beverage capsule comprising:

a body having a sidewall extending from an end wall to an opening; and  
a filter disposed in said body, said filter having an inner portion and an outer portion where the inner portion is spaced a greater distance from said end wall than the distance said outer portion is spaced from said end wall.

7. The filter capsule of claim 6, further comprising a diffusing surface disposed in said body downstream of where a fluid is intended to enter the opening of said capsule during use with an intended beverage preparing machine, said diffusing surface being adapted for diffusing fluid entering said capsule.

8. The beverage capsule of claim 6, further comprising a boss disposed in said body between said end wall and said filter for engaging said inner portion of said filter.

9. The beverage capsule of claim 8, further comprising a diffusing surface disposed on said boss downstream of where a fluid is intended to enter the opening of said capsule during use with an intended beverage preparing machine, said diffusing surface being adapted for diffusing fluid entering said capsule.

10. The beverage capsule of claim 8, wherein said boss is integrally formed with said base.

11. The beverage capsule of claim 6, further comprising at least one capsule key disposed on an exterior surface of said body for fitting to a corresponding at least one machine key element disposed on an interior surface of a capsule receiving chamber of a beverage preparing device for positioning the capsule in a desired orientation within said receiving chamber.

12. A beverage capsule intended for use in a beverage preparing machine, said beverage capsule comprising:

a body having a side wall extending from an end wall to an opening;  
a diffusing surface disposed in said body downstream of where a fluid is intended to enter the opening of said capsule during use with a beverage preparing machine, said diffusing surface being adapted to redirect fluid that engages said diffusing surface to desired locations within said capsule.

13. A beverage system as claimed in claim 12, wherein said diffusing surface has a cross-sectional surface area that is no greater than 20% of the cross-sectional surface area of the interior space of the capsule as measured in the same plane.

14. A beverage system as claimed in claim 12 wherein said diffusing surface is spaced from said end wall by a distance of no less than 20% and no more than 80% of the overall height of the capsule as measured from the end wall to the opening.

15. A beverage system as claimed in claim 12, further comprising a filter disposed in said capsule between said end wall and said diffusing surface.

16. A beverage capsule intended for use in a beverage preparing machine, said beverage capsule comprising:

- a body having a side wall extending from an end wall to an opening to define an interior space, said end wall including an extraction region that is adapted to be pierced to facilitate flow of beverage from said capsule;

- a filter disposed in said body to define an ingredients chamber, located between said opening and said filter, and an extraction chamber located between said filter and said end wall;

- a boss extending from said end wall into said interior space, said boss engaging said filter to define a tented filter zone wherein an inner portion of said filter is spaced a further distance from said end wall than an outer portion of said filter;

- one or more ingredients disposed in said ingredients chamber for preparing a desired beverage; and

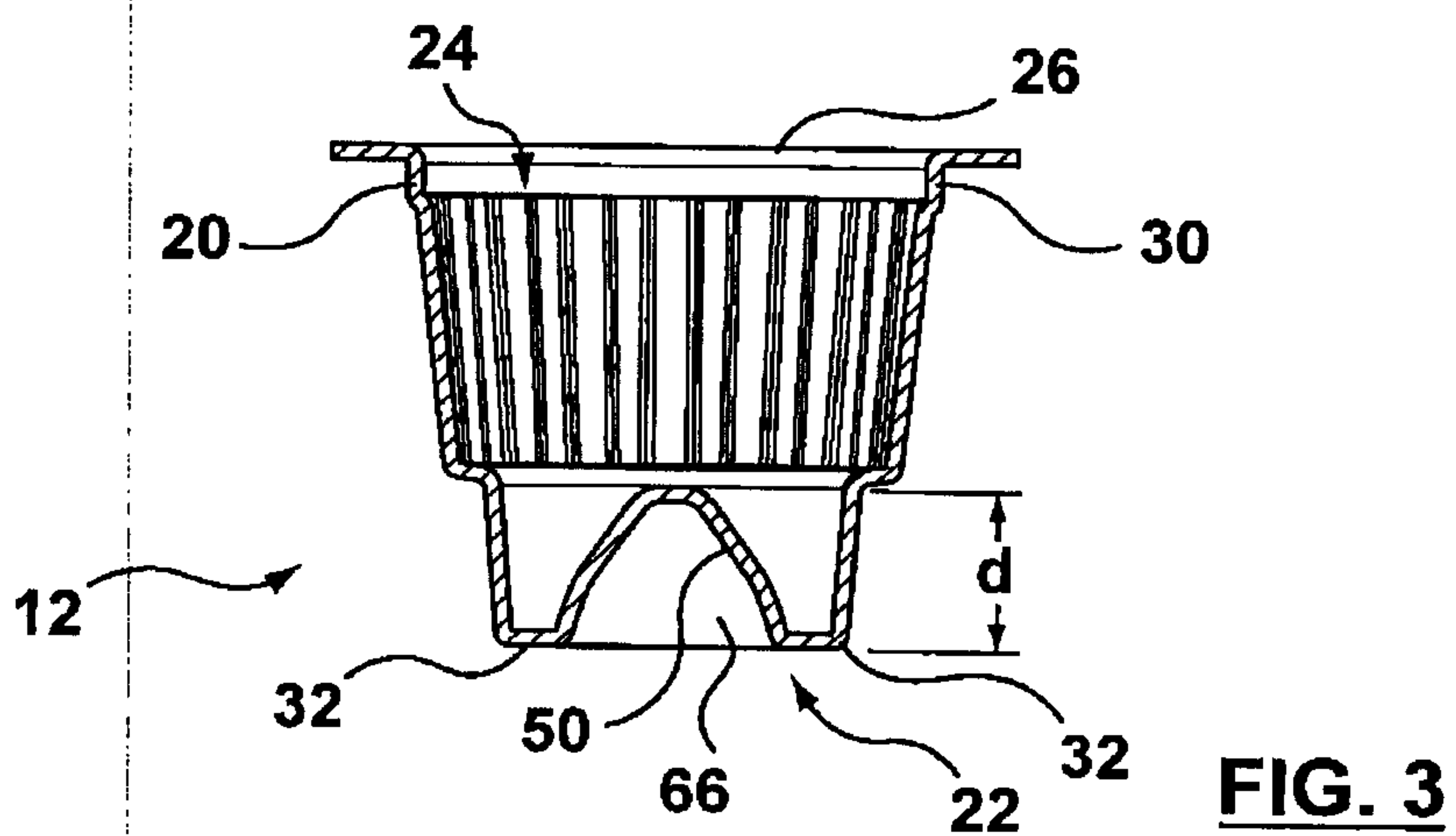
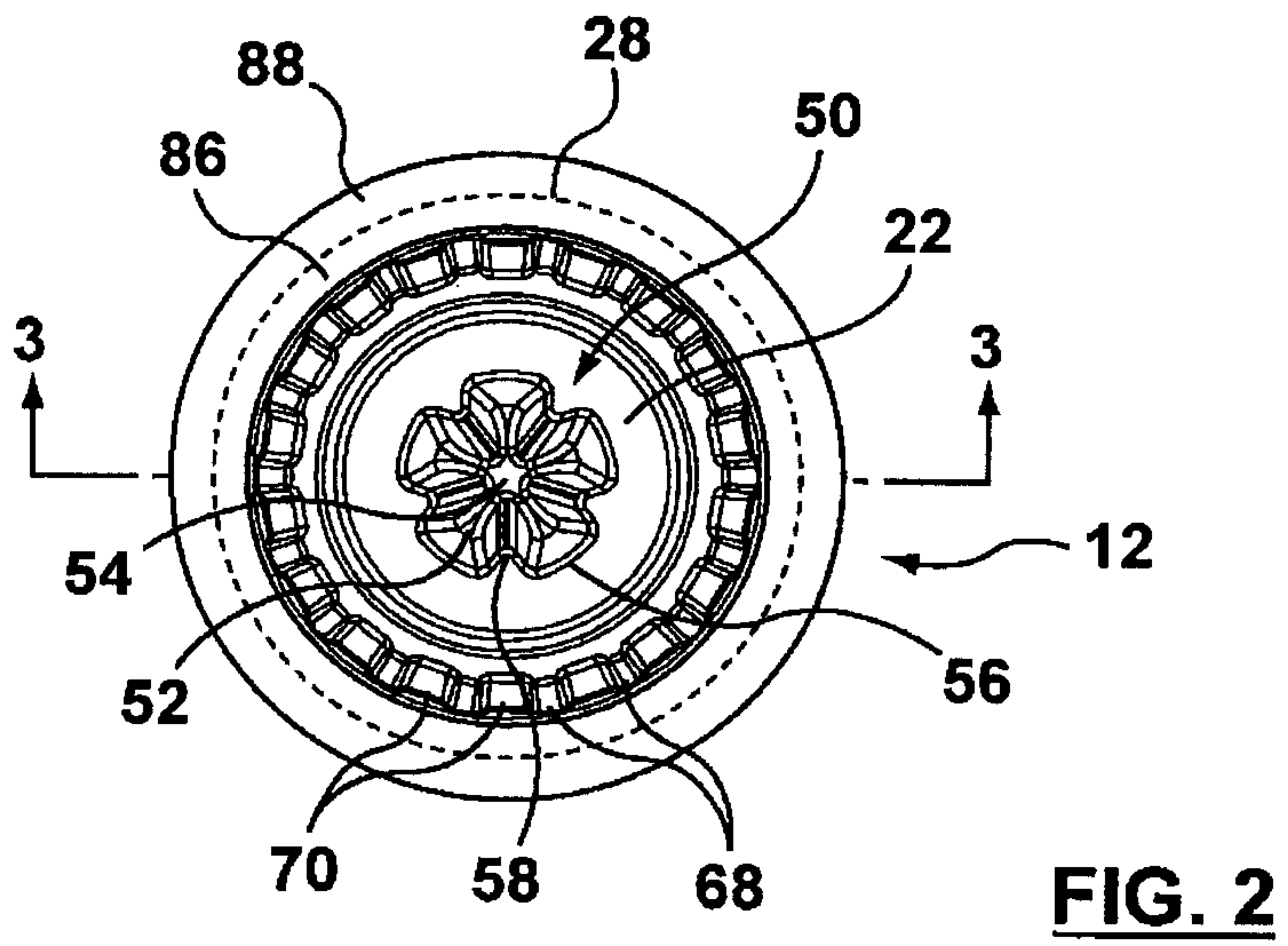
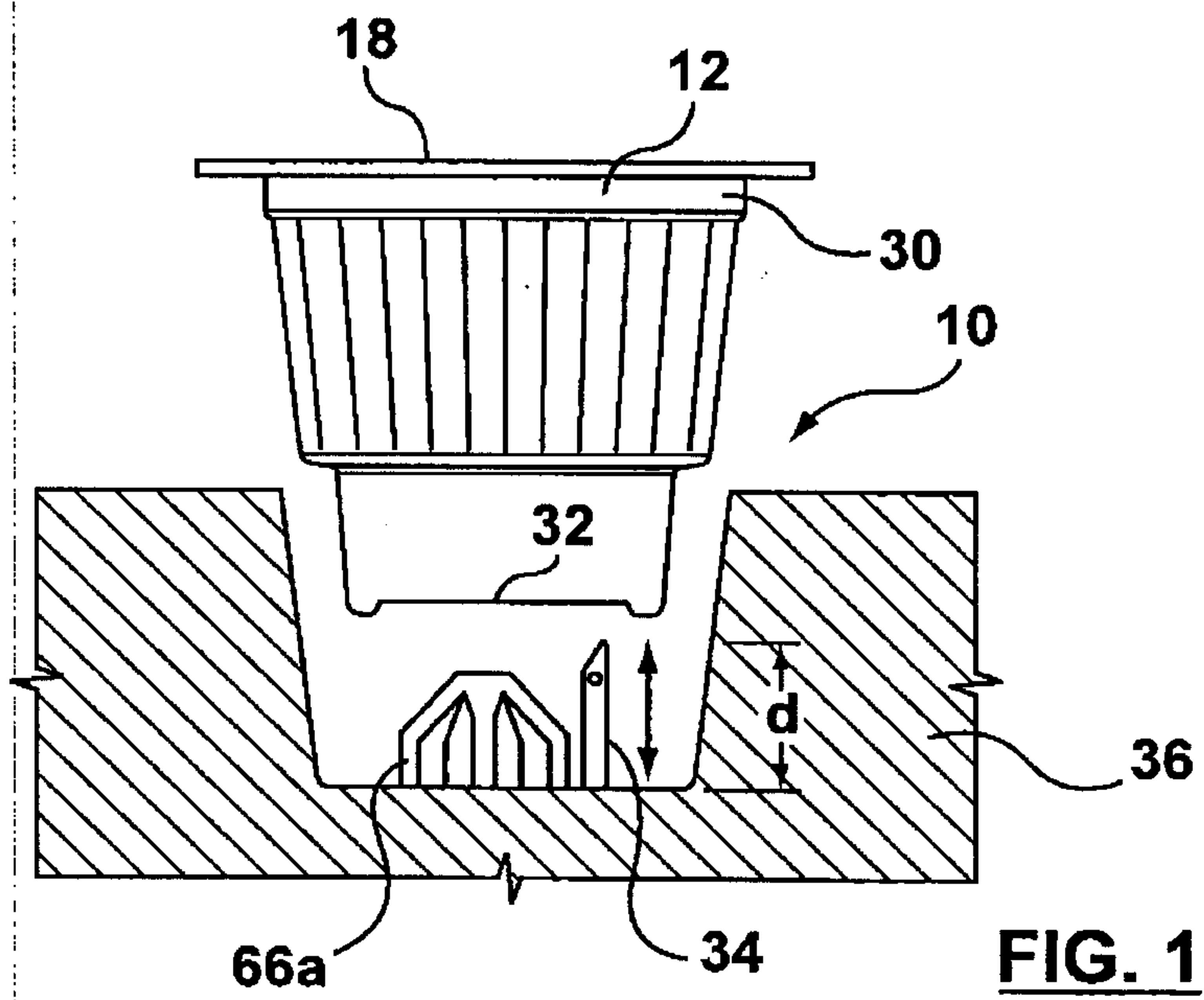
- a cover for covering said opening.

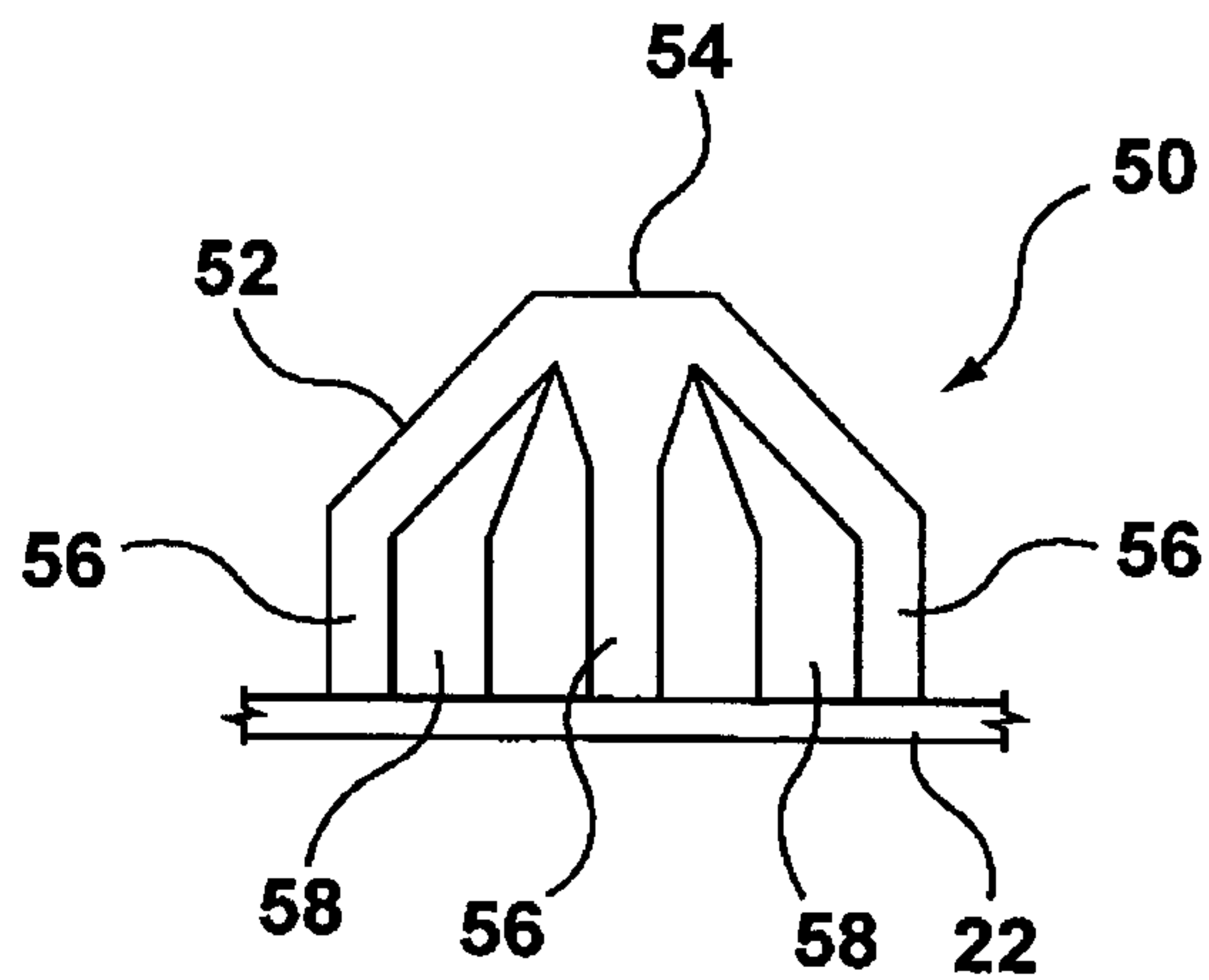
17. The beverage capsule of claim 16, further comprising a diffusing surface disposed in said body downstream of where a fluid is intended to enter the opening of said capsule during use with a beverage preparing machine, said diffusing surface being adapted to redirect fluid that engages said diffusing surface to desired locations within said capsule.



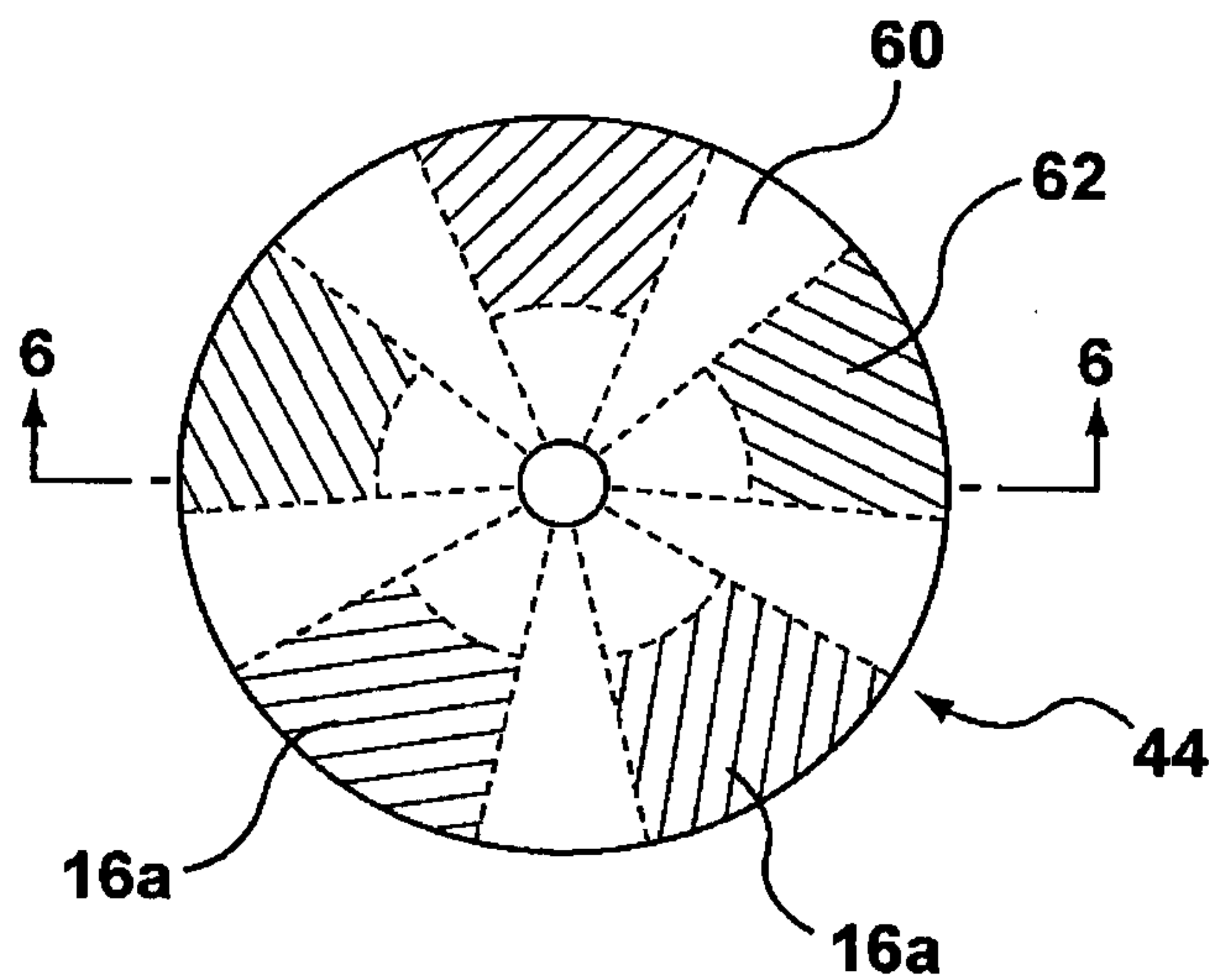
18. The beverage capsule of claim 16, further comprising a ledge defined on the side wall of said body for supporting said filter.

19. The beverage capsule of claim 16, wherein said side wall of said body defines a plurality of channels extending at least partially between said extraction chamber and said opening.

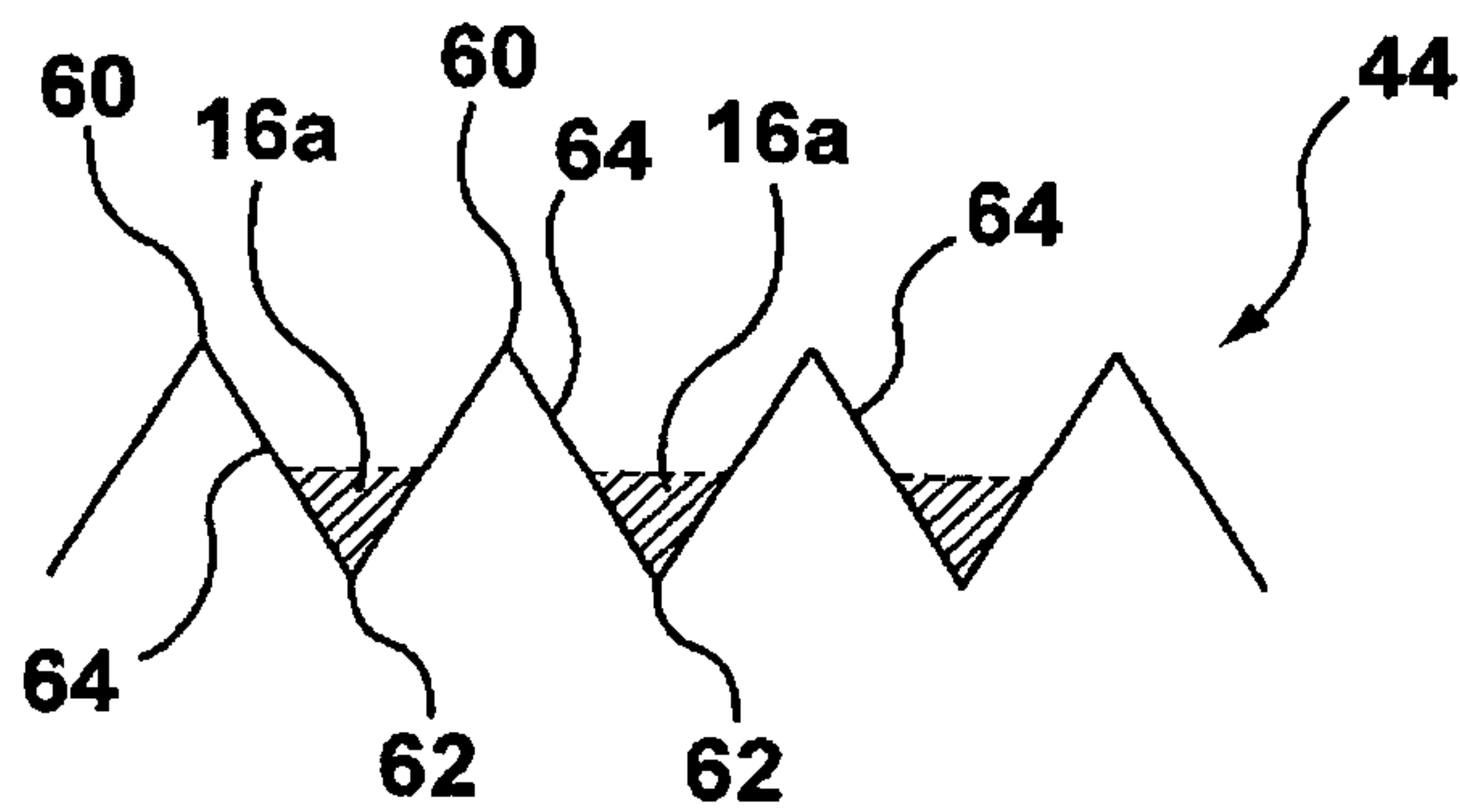




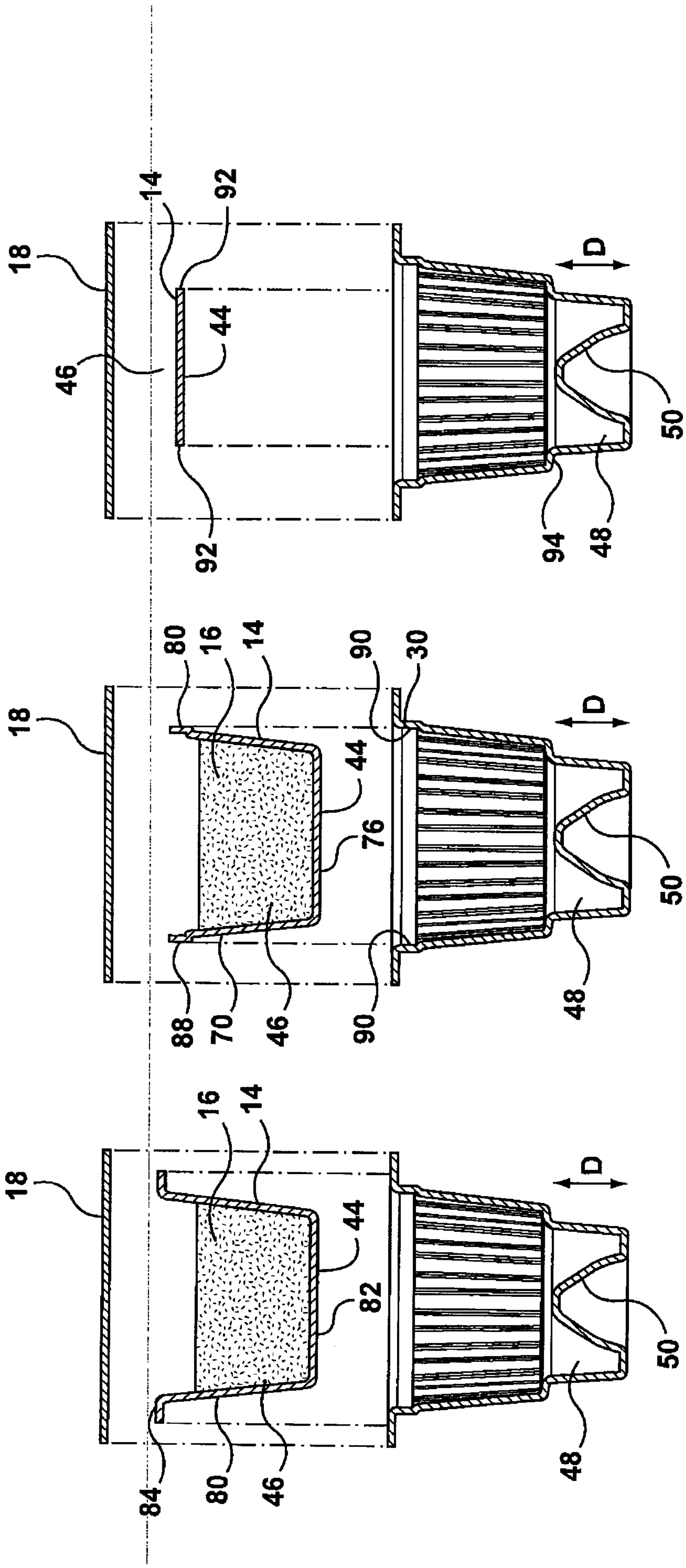
**FIG. 4**



**FIG. 5**



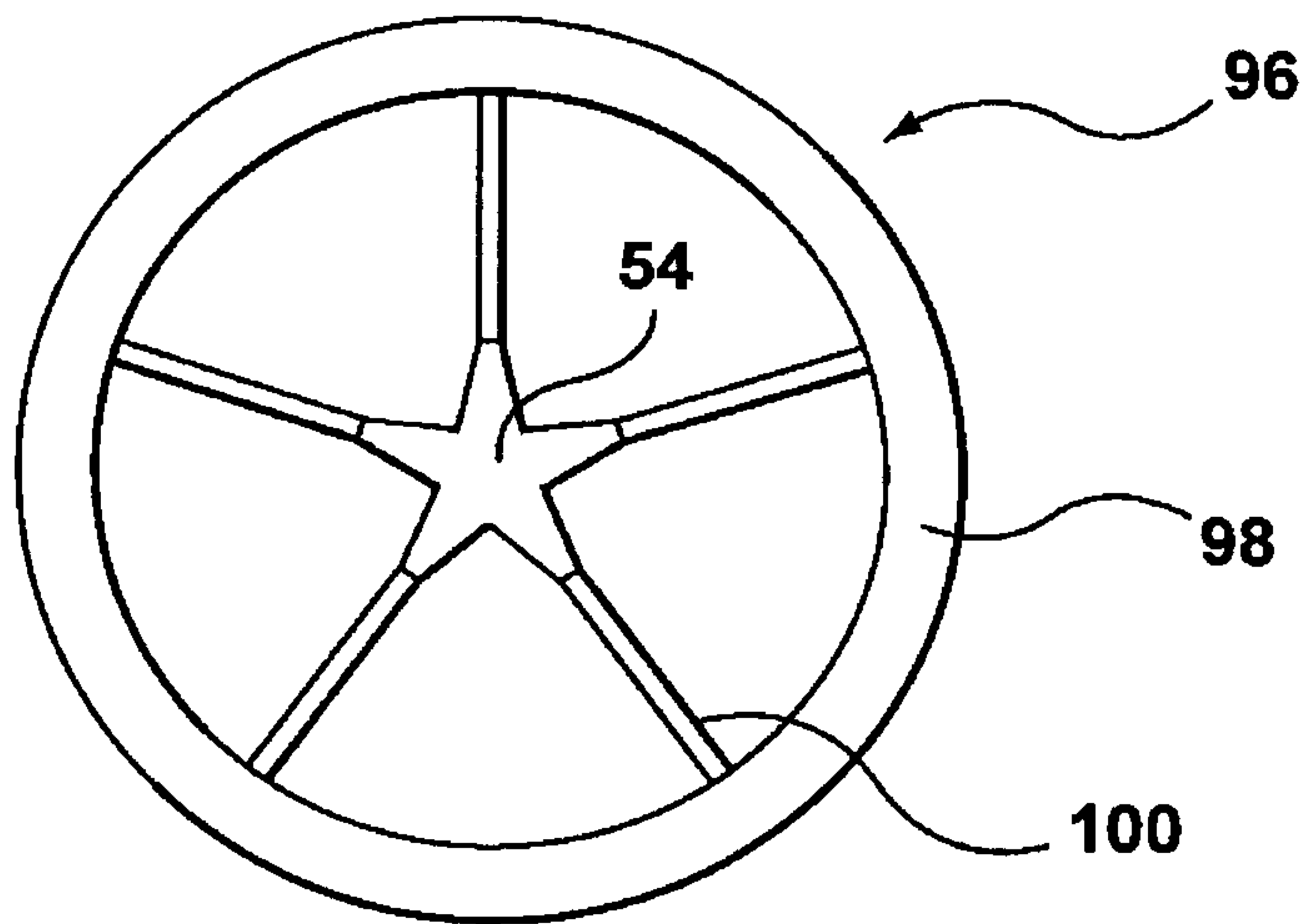
**FIG. 6**



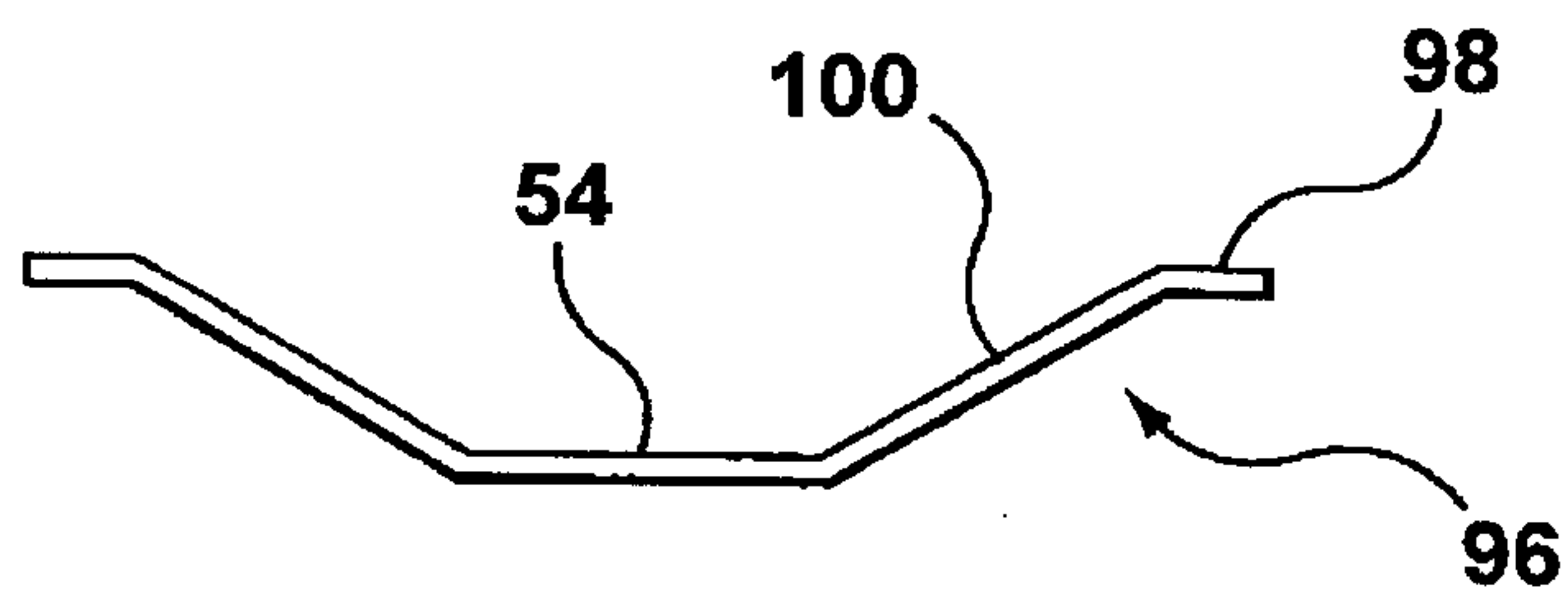
**FIG. 7**

**FIG. 8**

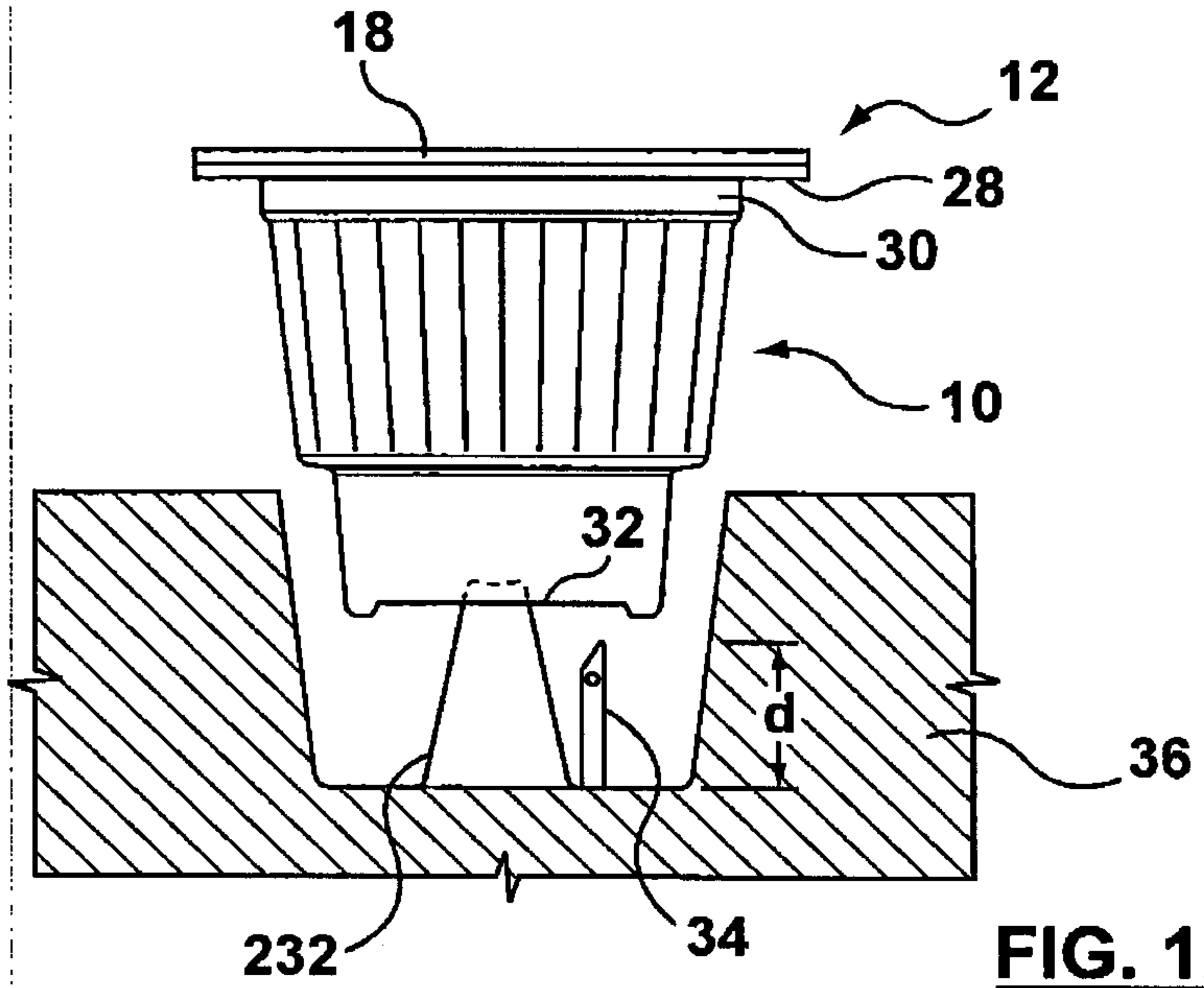
**FIG. 9**



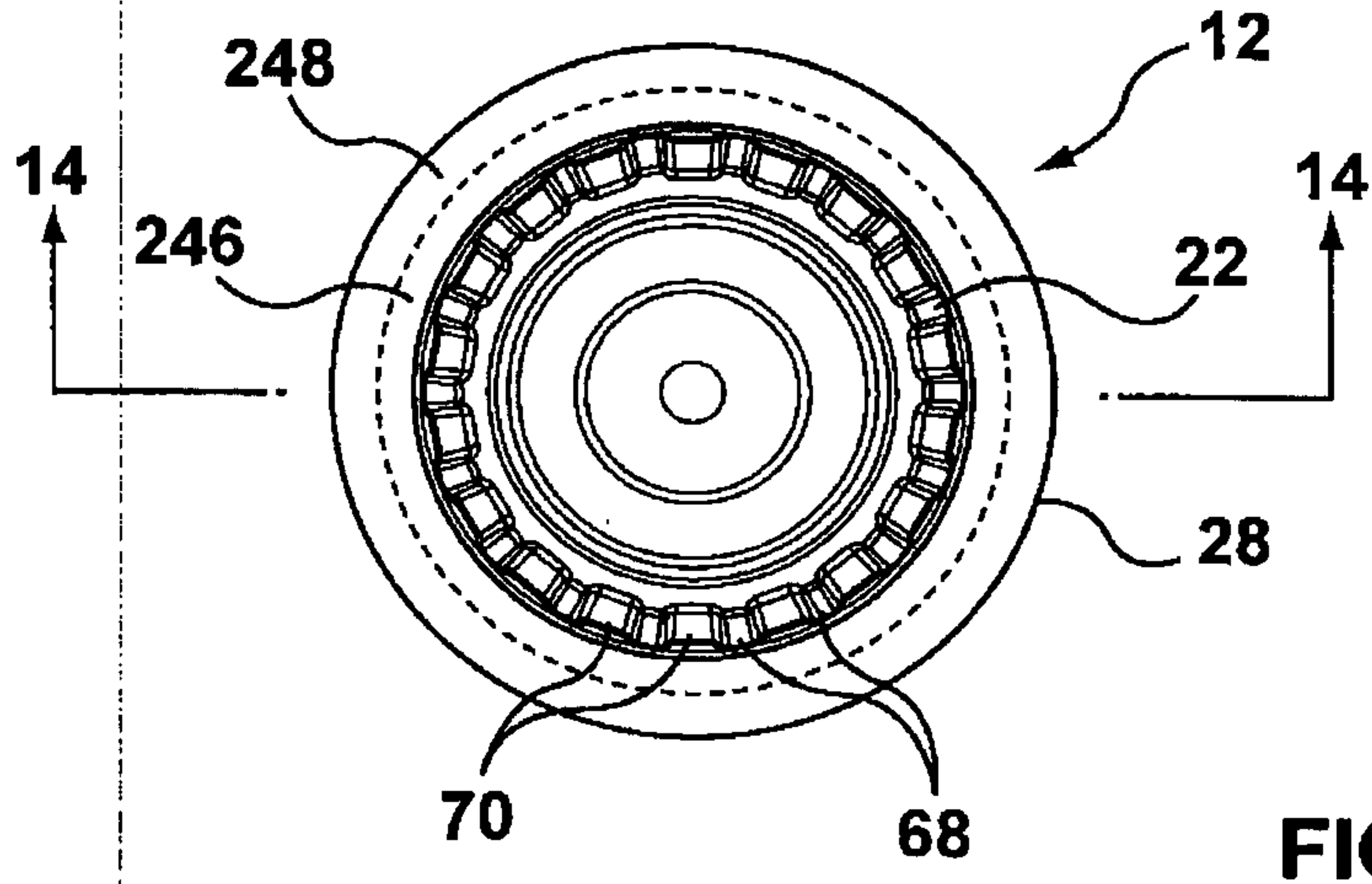
**FIG. 10**



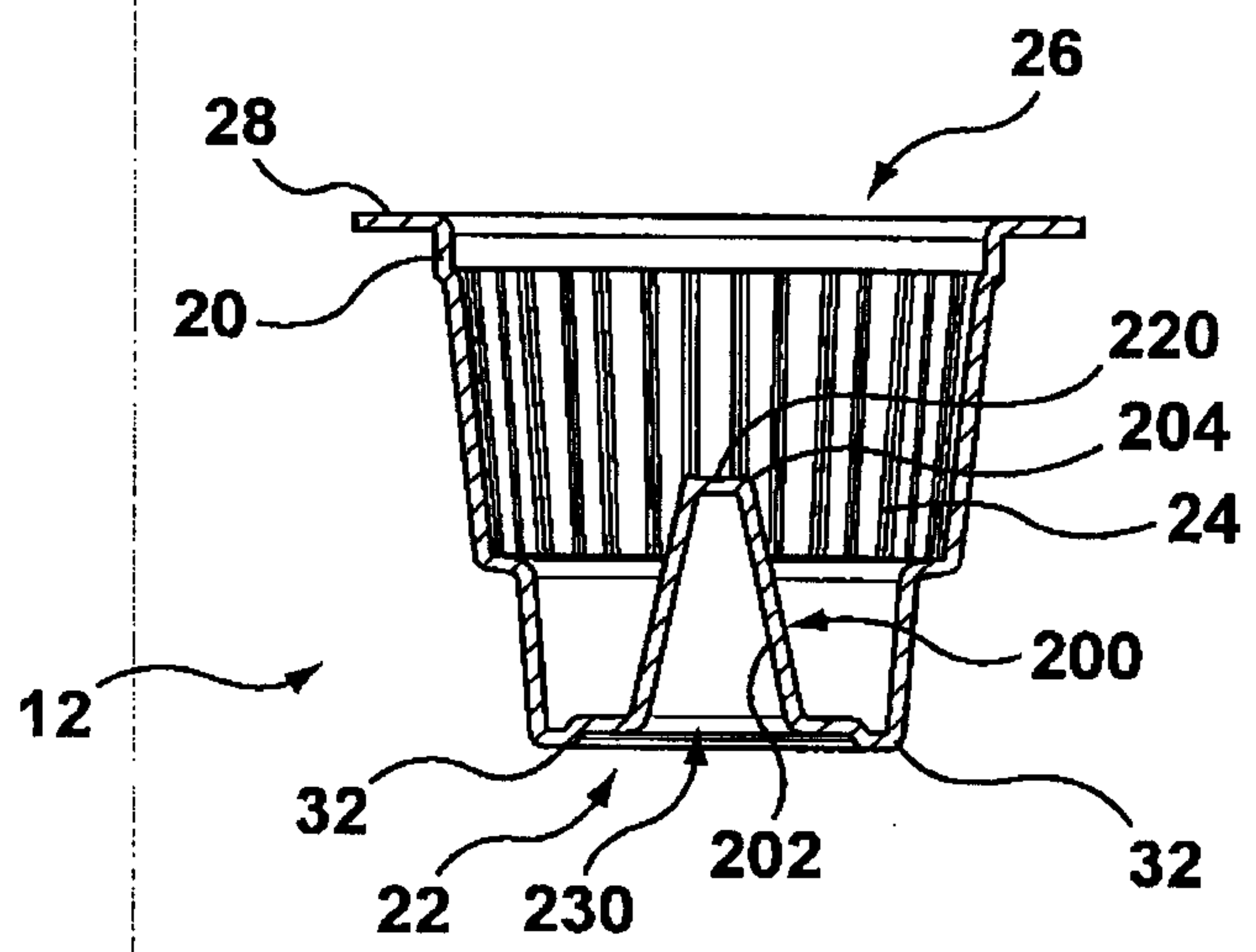
**FIG. 11**



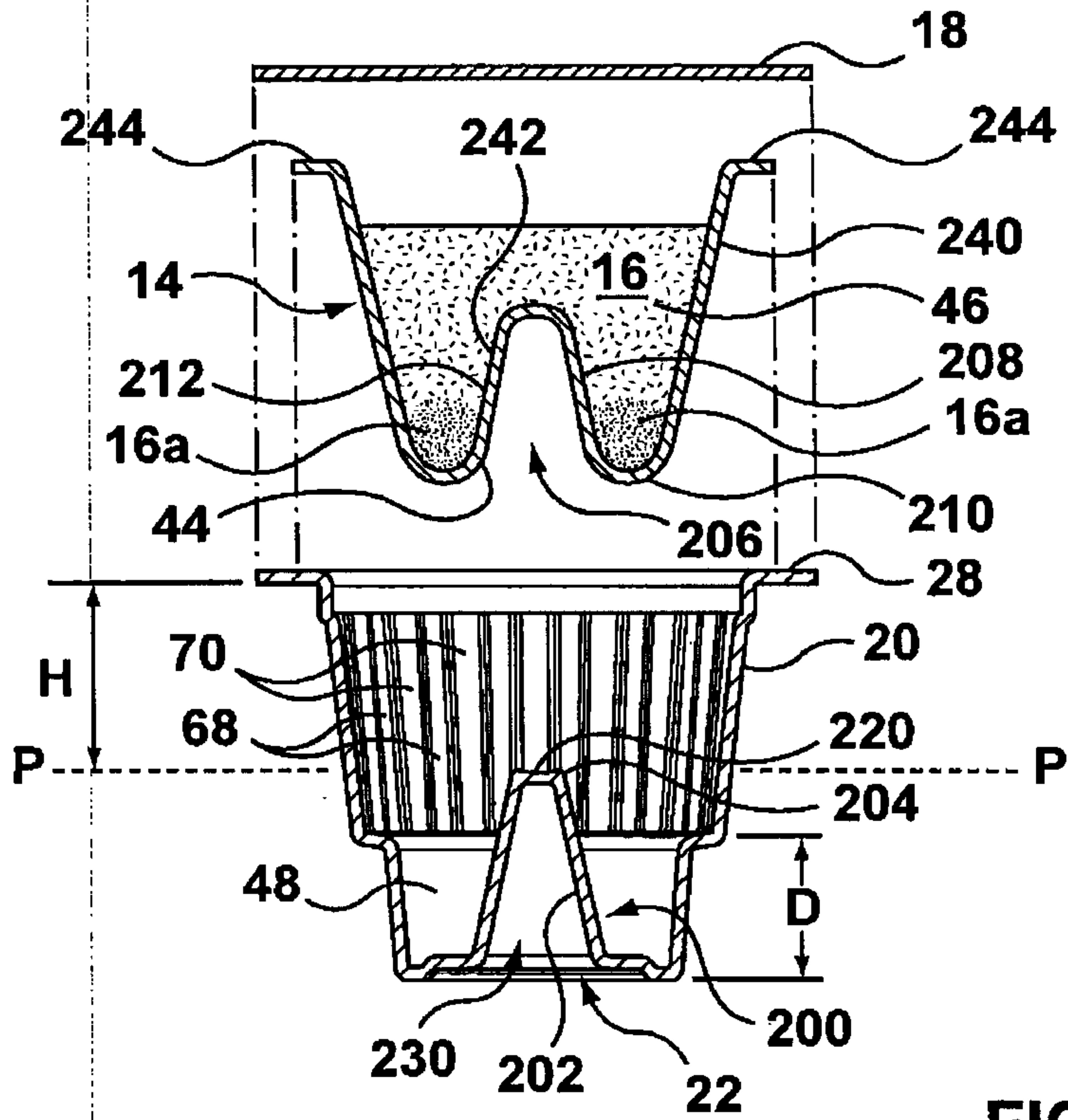
**FIG. 12**



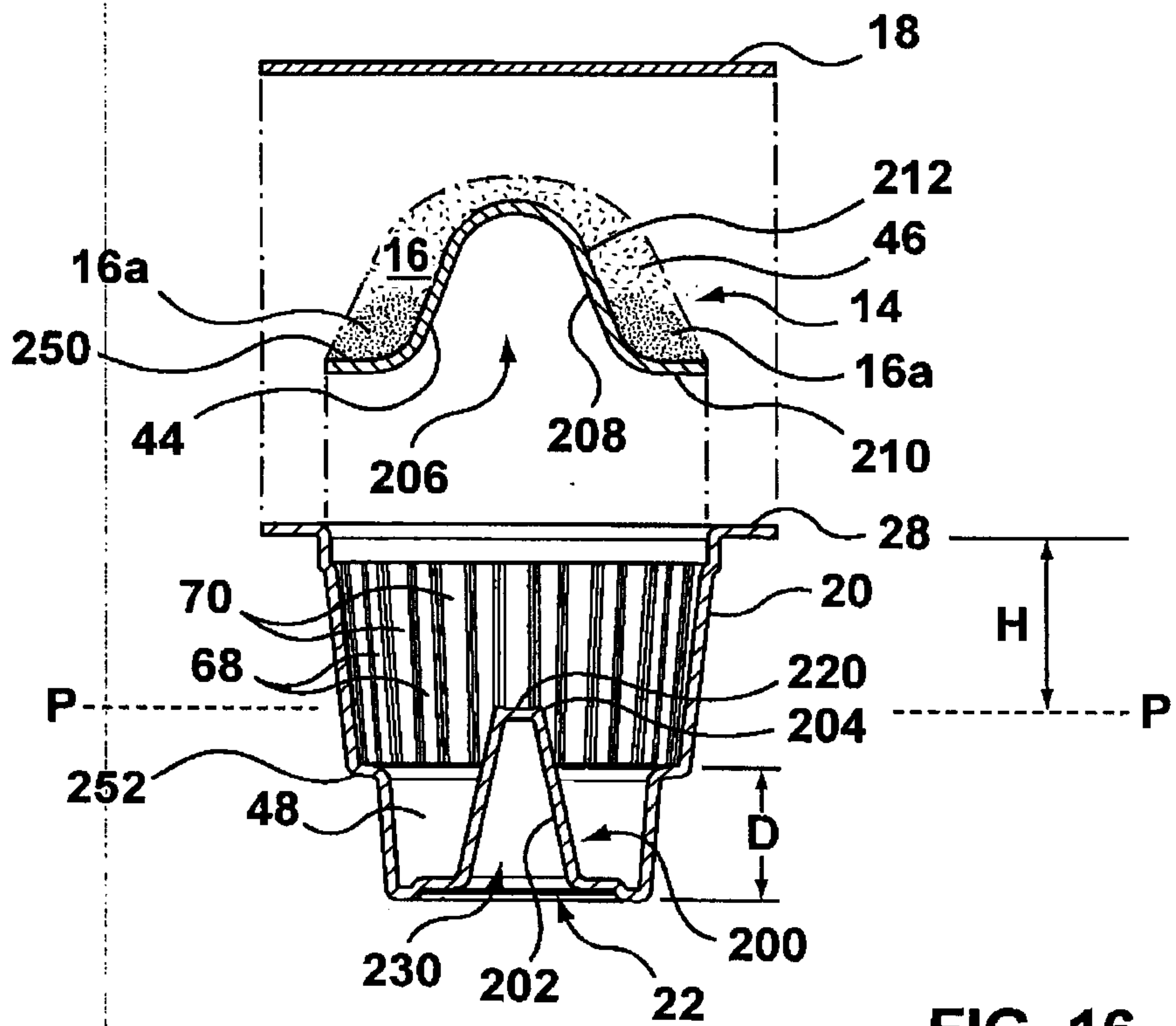
**FIG. 13**



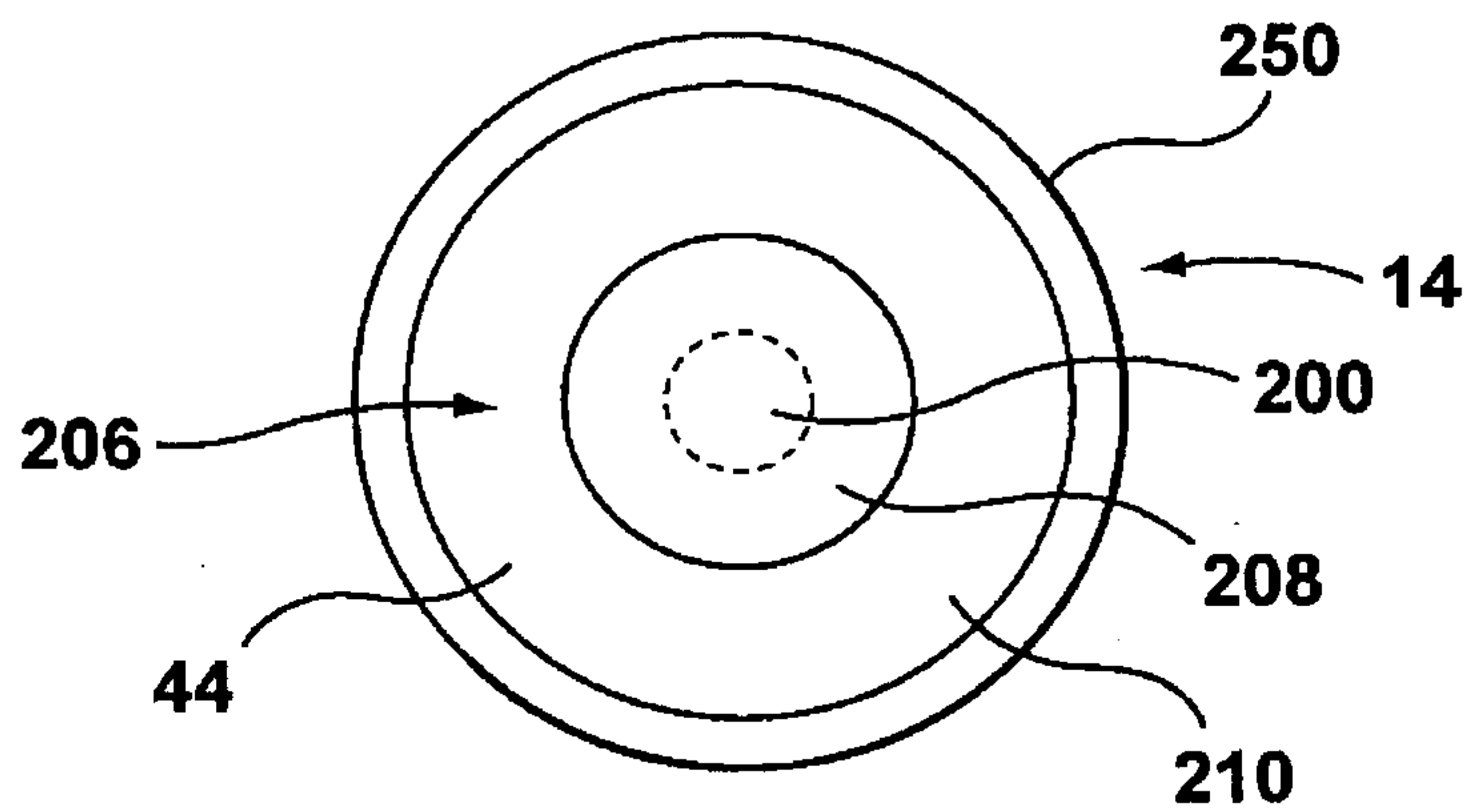
**FIG. 14**



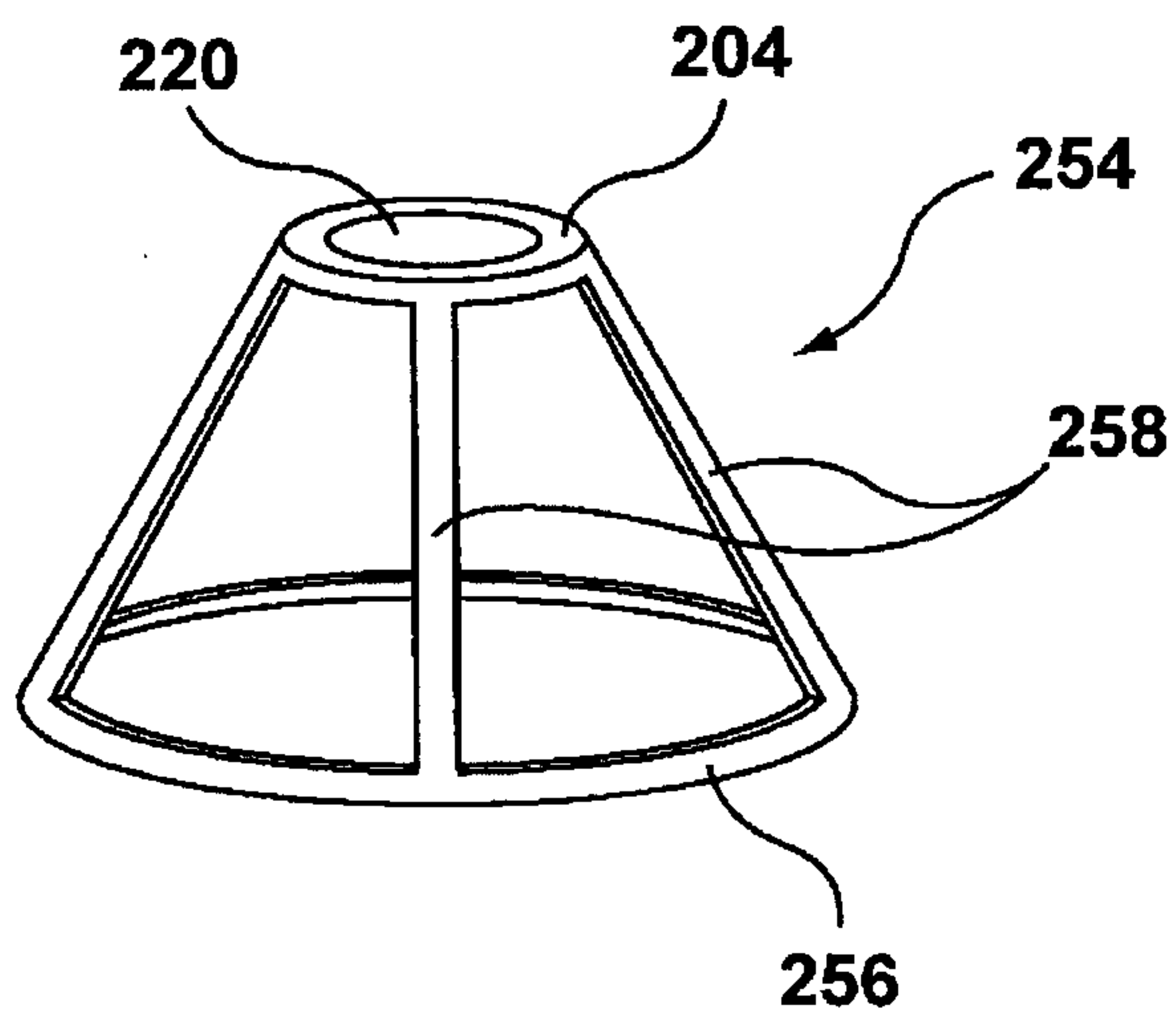
**FIG. 15**



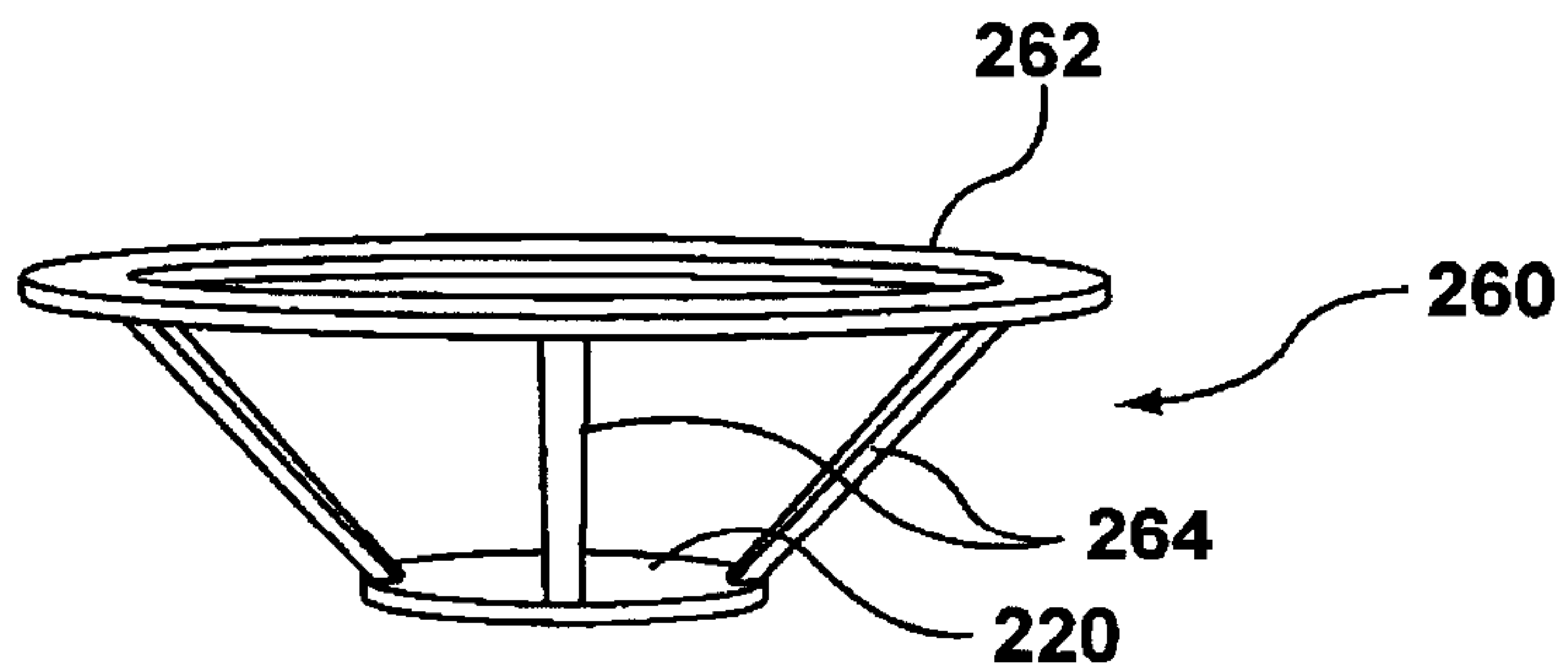
**FIG. 16**



**FIG. 17**



**FIG. 18**



**FIG. 19**



