



US005561920A

# United States Patent [19]

[11] Patent Number: **5,561,920**

Graham et al.

[45] Date of Patent: **\* Oct. 8, 1996**

[54] **SHOE CONSTRUCTION HAVING AN ENERGY RETURN SYSTEM**

[75] Inventors: **Kenneth D. Graham**, Stoneham; **Bernie Allen**, Jamaica Plain; **Michael Kirk**, Swampscott; **Stephen Francis**, Newburyport; **Edward Tavino**, Swampscott, all of Mass.; **Kenton Geer**, Exeter; **Gary J. Troy**, Nottingham, both of N.H.

[73] Assignee: **Hyde Athletic Industries, Inc.**, Peabody, Mass.

[\*] Notice: The term of this patent shall not extend beyond the expiration date of Pat. No. 5,070,629.

4,506,460	3/1985	Rudy .	
4,510,700	4/1985	Brown .	
4,534,121	8/1985	Autry .	
4,541,184	9/1985	Leighton .	
4,561,195	12/1985	Onoda et al. ....	36/28
4,597,196	7/1986	Brown .	
4,598,487	7/1986	Misevich .	
4,608,768	9/1986	Cavanaugh .....	36/28
4,619,056	10/1986	Lin et al. .	
4,709,489	12/1987	Welter .....	36/27
4,712,314	12/1987	Skozoff .	
4,757,616	7/1988	Hills .	
4,766,679	8/1988	Bender .	
4,768,795	9/1988	Ito . .	
4,771,554	9/1988	Hannemann .	
4,805,319	2/1989	Tankel .....	36/28

(List continued on next page.)

### FOREIGN PATENT DOCUMENTS

[21] Appl. No.: **331,142**

72214	1/1943	Czech Rep. ....	36/28
2454899	12/1980	France .	

[22] Filed: **Oct. 17, 1994**

### Related U.S. Application Data

[63] Continuation of Ser. No. 982,824, Nov. 30, 1992, abandoned, and a continuation of Ser. No. 75,037, Jun. 10, 1993, abandoned, which is a division of Ser. No. 682,690, Apr. 9, 1991, abandoned, which is a continuation-in-part of Ser. No. 427,764, Oct. 26, 1989, Pat. No. 5,070,629.

[51] Int. Cl.<sup>6</sup> ..... **A43B 23/08**

[52] U.S. Cl. .... **36/27; 36/28; 36/69; 36/7.8**

[58] Field of Search ..... **36/27, 28, 35 R, 36/7.8, 37, 38, 7.3, 25 R, 114, 69, 122**

### [56] References Cited

#### U.S. PATENT DOCUMENTS

465,513	12/1891	Applegate .	
812,496	2/1906	Irwin .....	36/37
2,011,945	8/1935	Mathi .	
2,735,185	2/1956	Naphtaz .	
2,913,837	11/1959	Geuder .	
3,332,262	7/1967	Schillizzi .	
3,798,801	3/1974	Gros-Lovis .	
4,297,796	11/1981	Stirtz et al. ....	36/28
4,327,504	5/1982	Welsch .	
4,503,576	3/1985	Brown .	

Primary Examiner—Paul T. Sewell  
Assistant Examiner—Marie Denise Patterson  
Attorney, Agent, or Firm—Wolf, Greenfield & Sacks, P.C.

### [57] ABSTRACT

A shoe construction having an energy return system together with features providing cushioning and stability. The energy return system includes a rigid frame having a torsional rigidity bar in the midfoot area integrally connecting annular walls in the forefoot and heel areas of the midsole. A net of monofilaments or fibers is secured under tension in the areas defined by the annular walls with the net positioned over an open area in the midsole. A cantilevered system of support pads is positioned in the arch area to support the medial side of the midfoot.

The energy return system also includes a rigid frame having annular walls in the heel area. A net of fibers is secured under tension in the area defined by the heel annular walls. The open areas can have inserted within them a variety of inserts to view the components of the energy return system from outside the shoe.

**4 Claims, 17 Drawing Sheets**

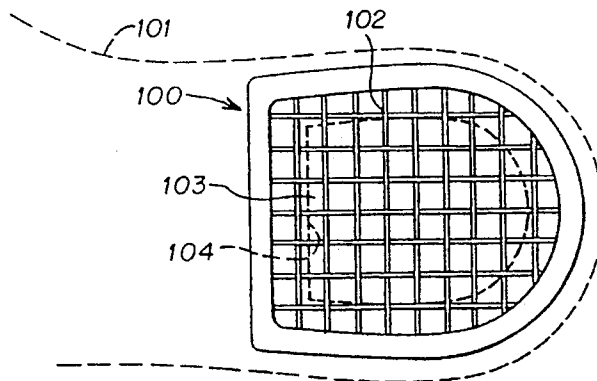

---

U.S. PATENT DOCUMENTS			
4,815,221	3/1989	Diaz .	
4,878,300	11/1989	Bogaty .....	36/30 R
4,878,301	11/1989	Kiyosawa .....	36/37
4,879,821	11/1989	Graham et al .	
		4,910,887	3/1990 Turner et al .
		4,918,841	4/1990 Turner et al .
		4,970,807	11/1990 Andgrie et al .
		5,005,300	4/1991 Diaz et al. .... 36/28
		5,042,174	8/1991 Nichols .
		5,070,629	12/1991 Graham et al. .... 36/28
		5,084,987	7/1992 Flemming .

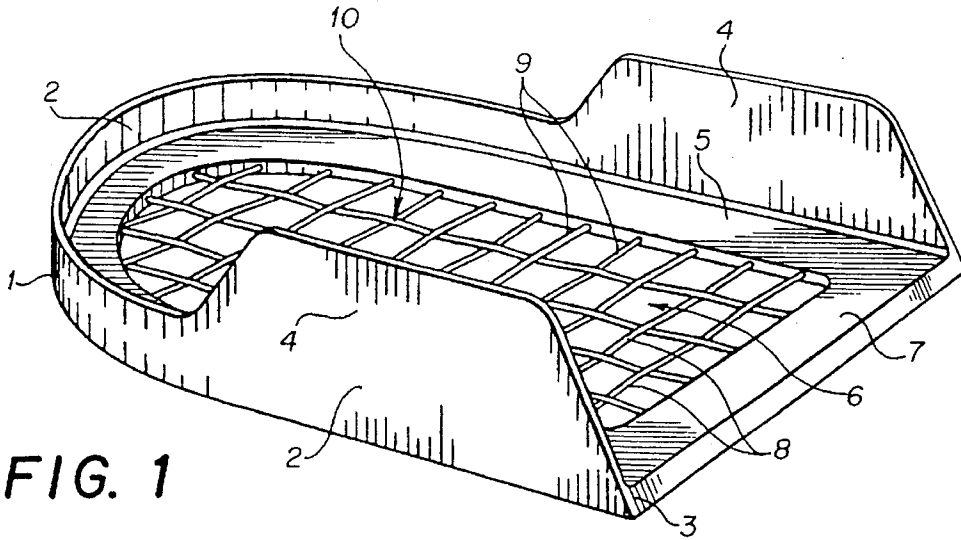

FIG. 1

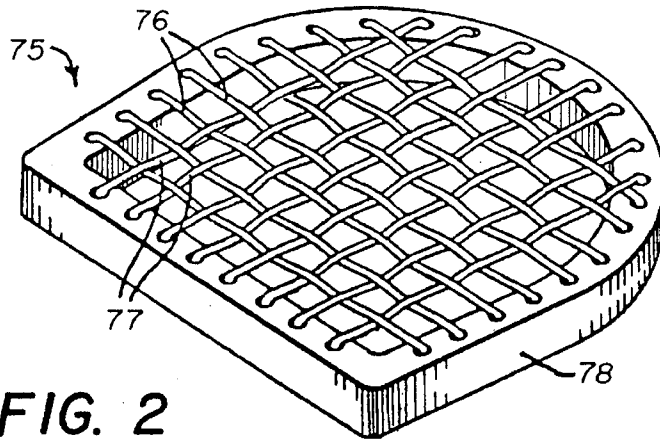

FIG. 2

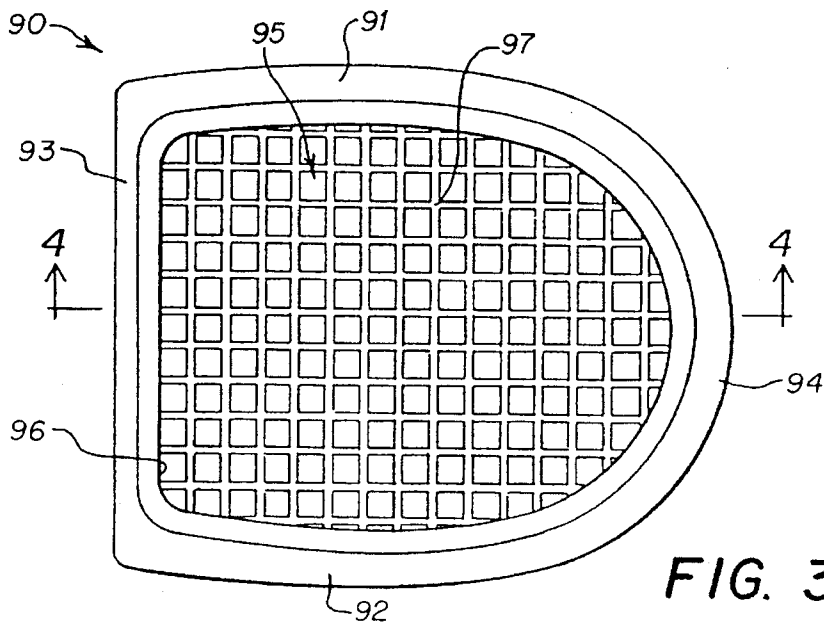

FIG. 3

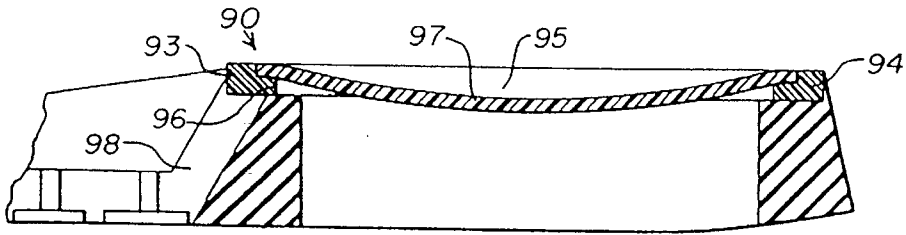

FIG. 4

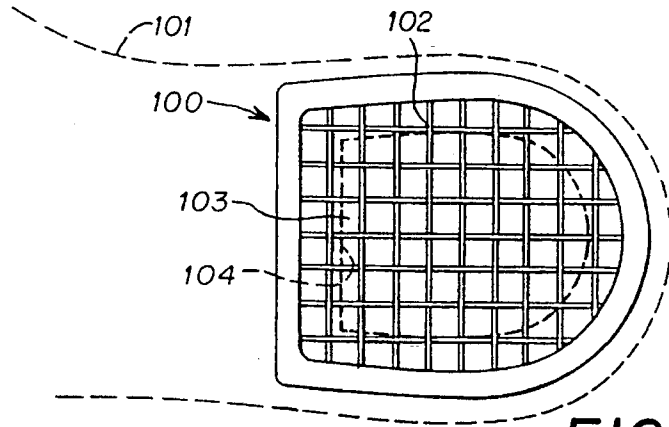

FIG. 5

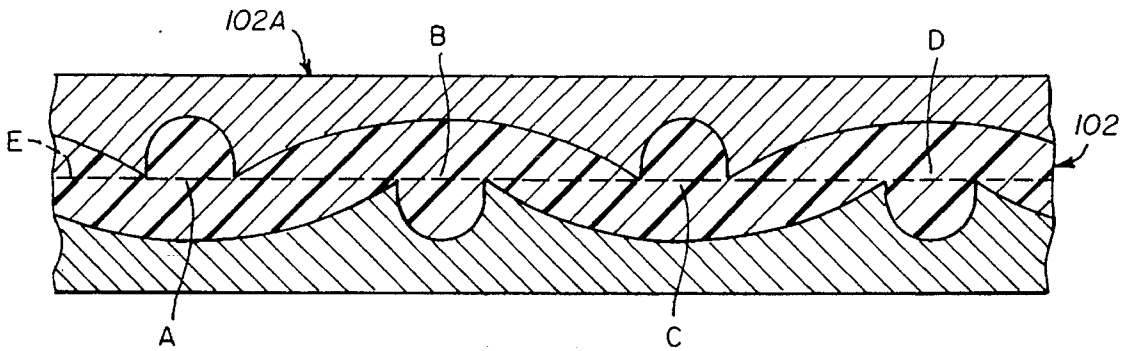

FIG. 6

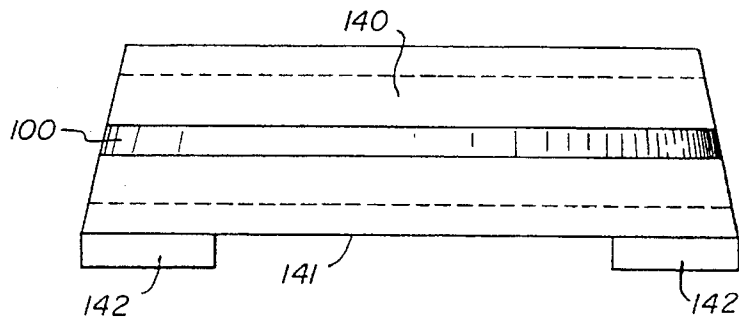

FIG. 7

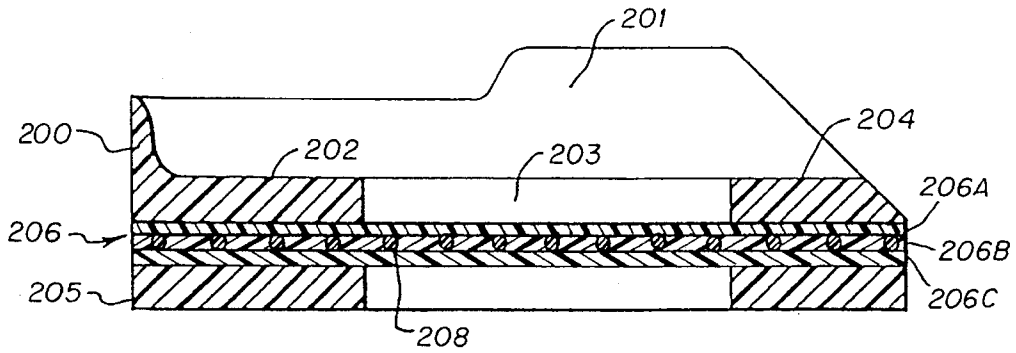

FIG. 8

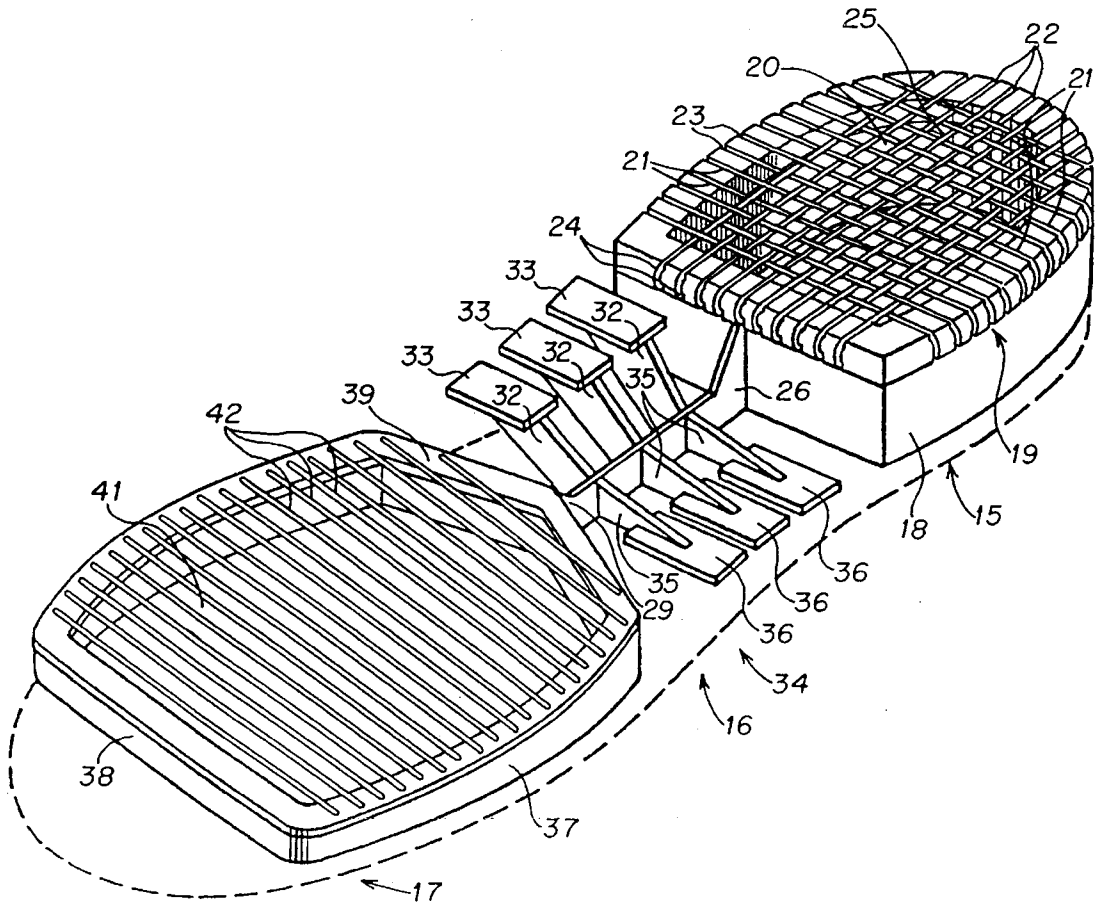

FIG. 9

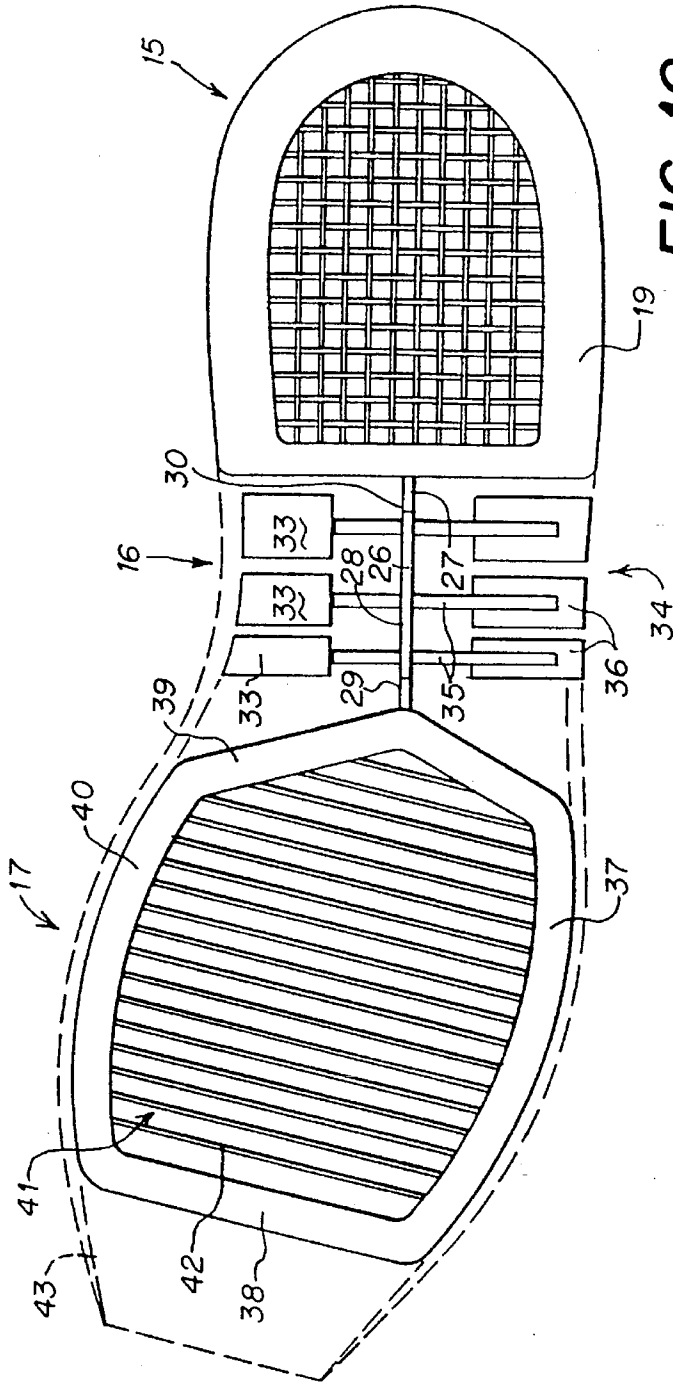

FIG. 10

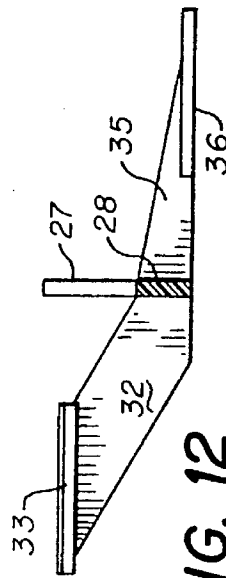

FIG. 12

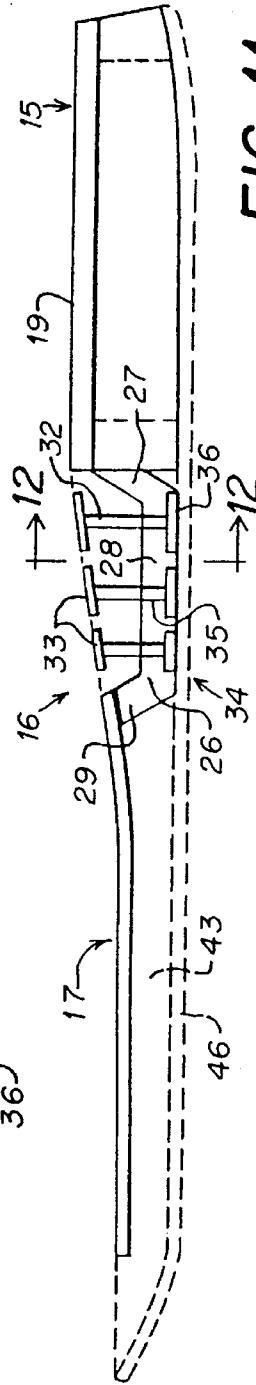

FIG. 11

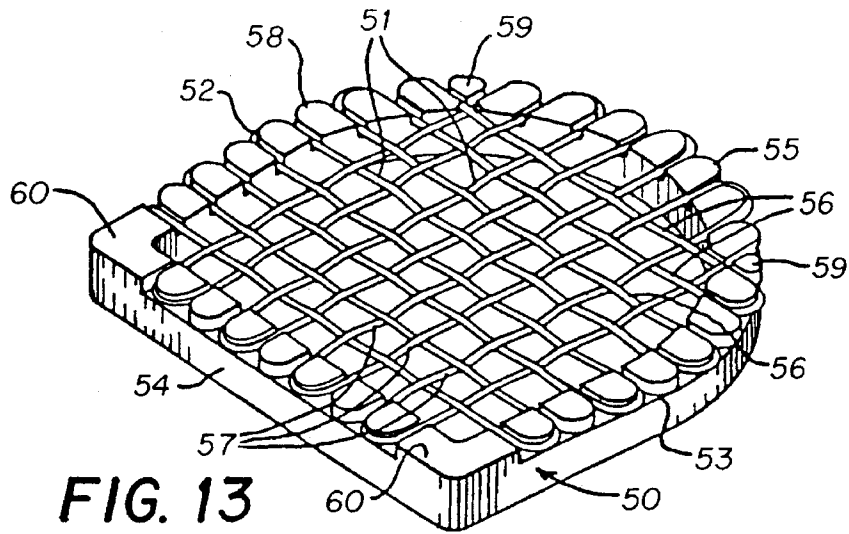

FIG. 13

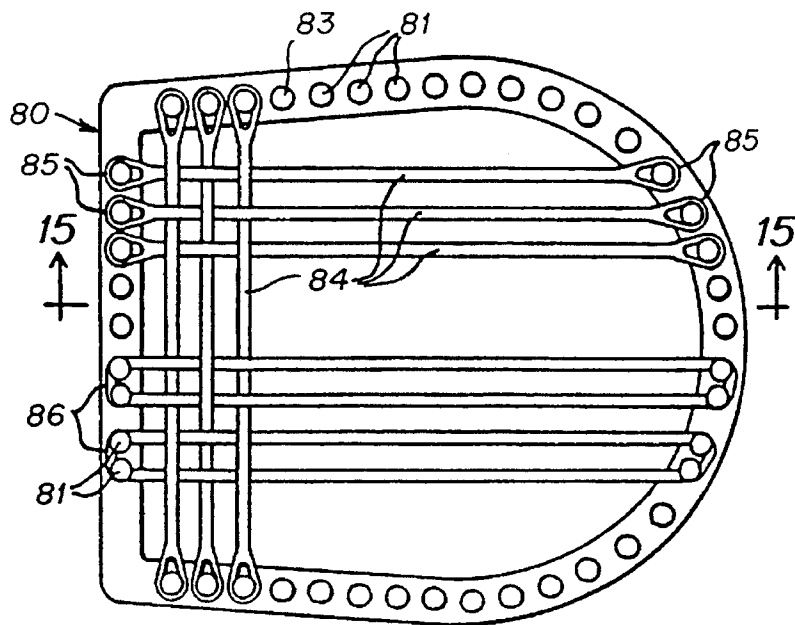

FIG. 14

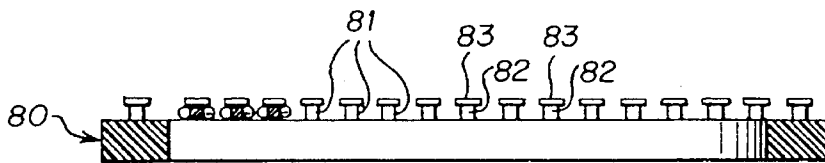

FIG. 15

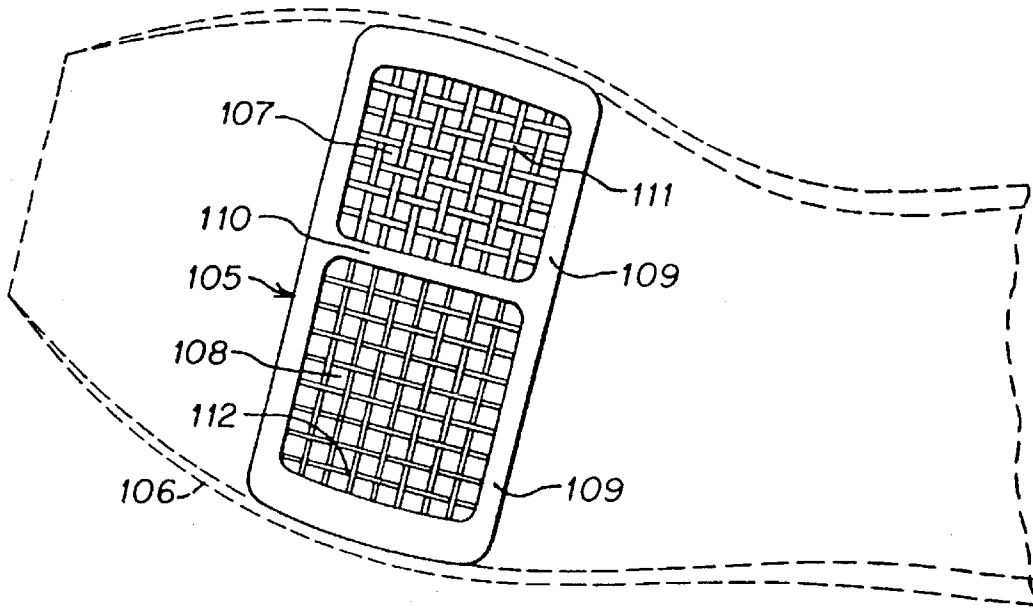

FIG. 16

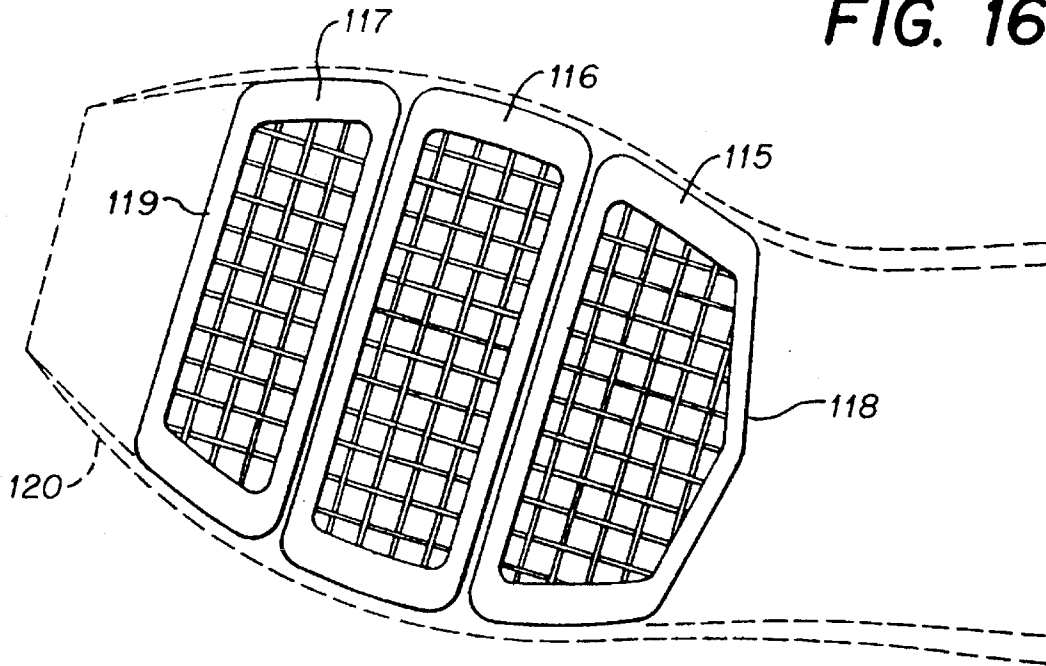

FIG. 17



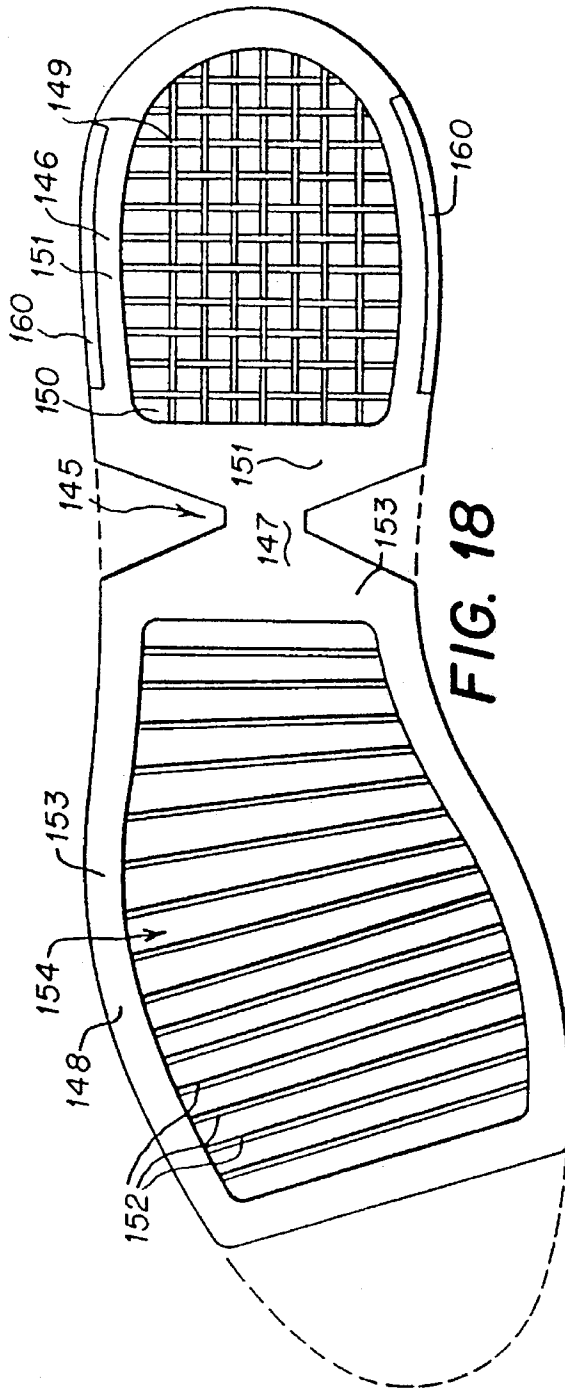

FIG. 18

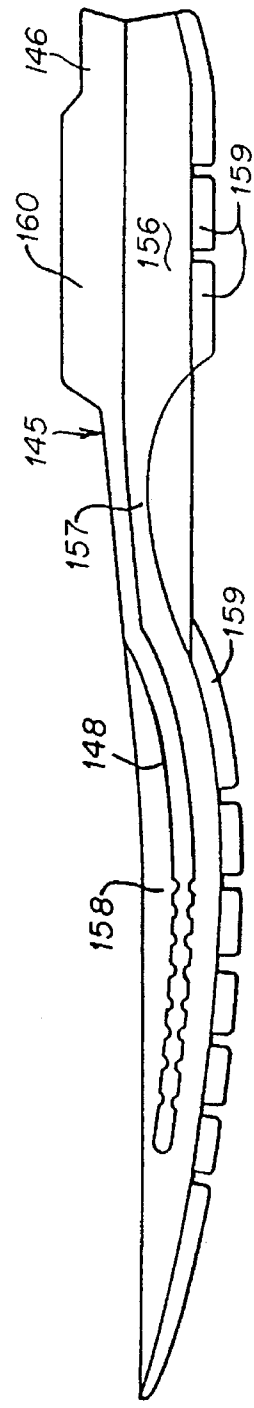

FIG. 19

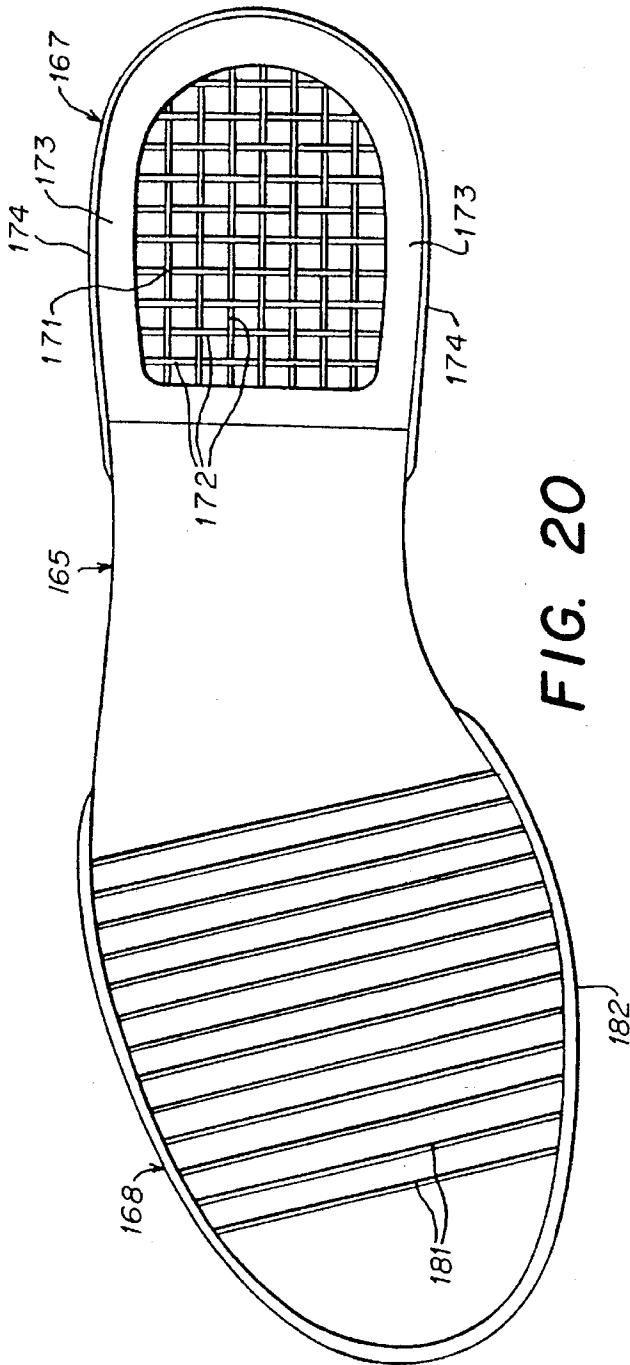

FIG. 20

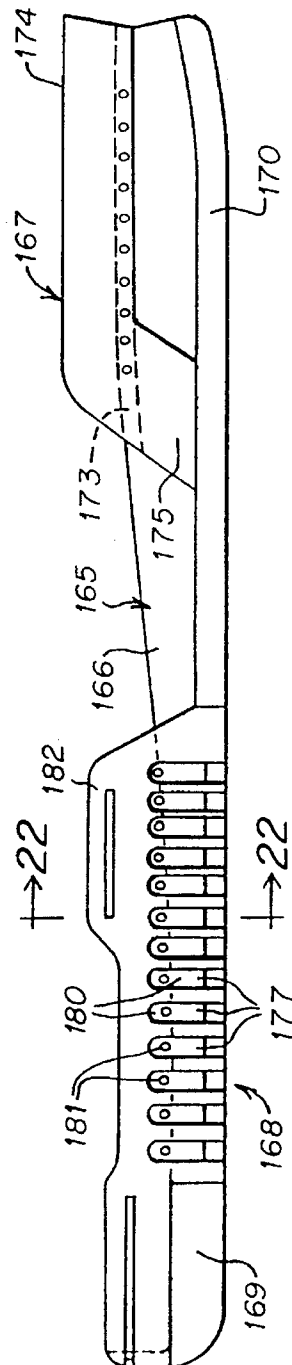

FIG. 21

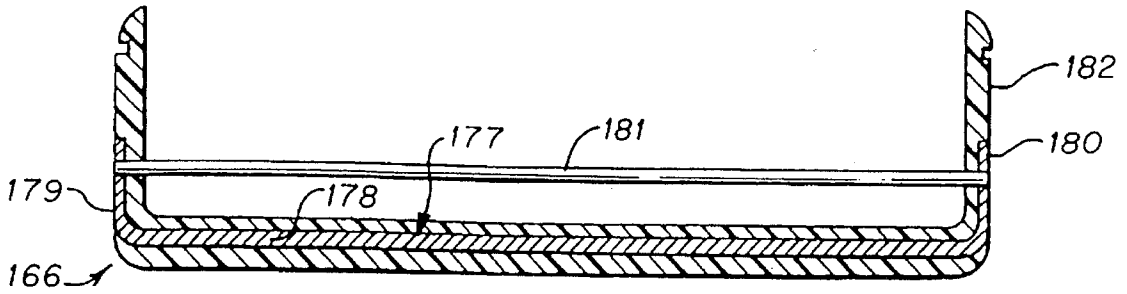

FIG. 22

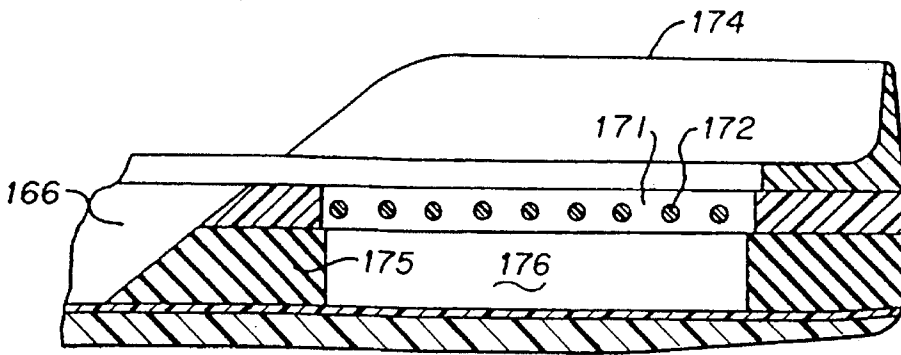

FIG. 23

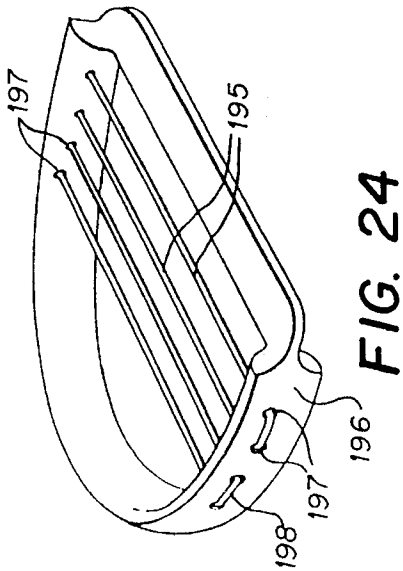

FIG. 24

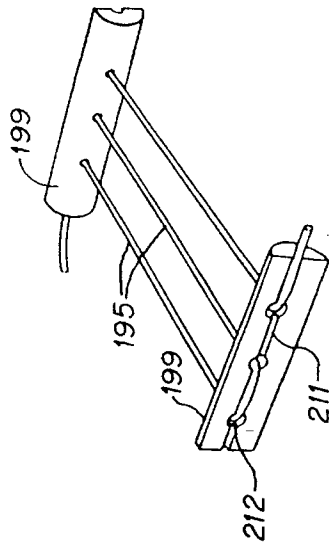

FIG. 25

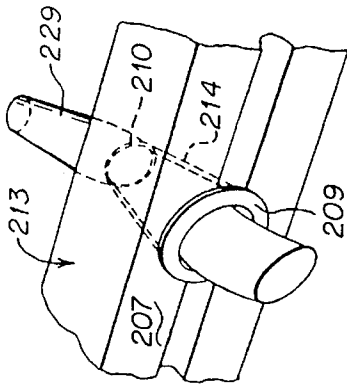

FIG. 26

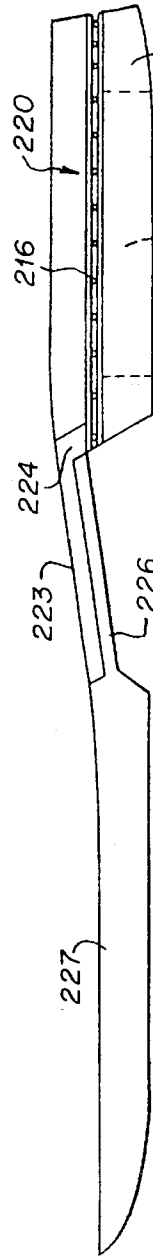

FIG. 27

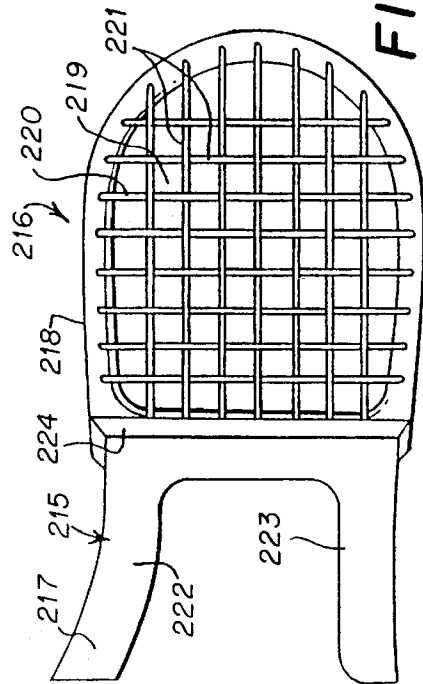

FIG. 28

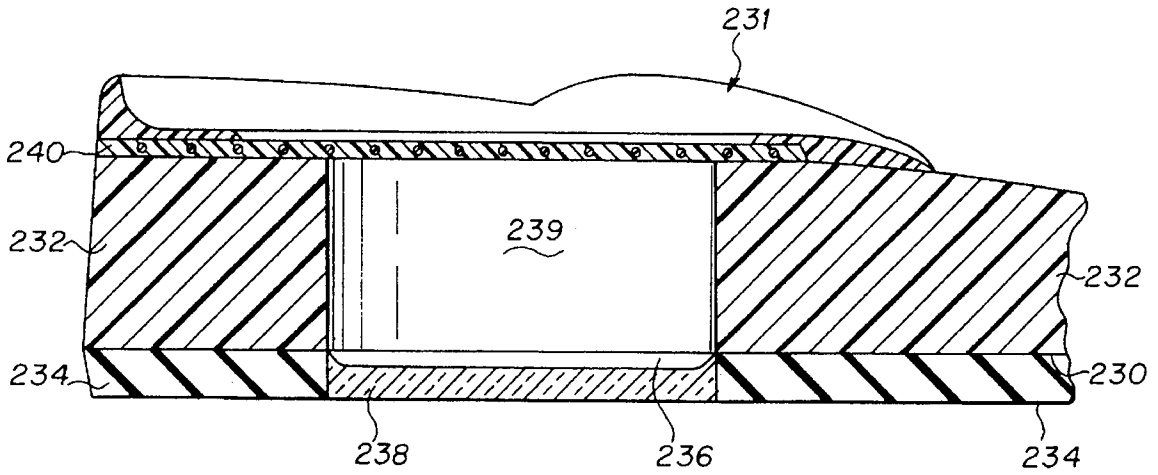

FIG. 29

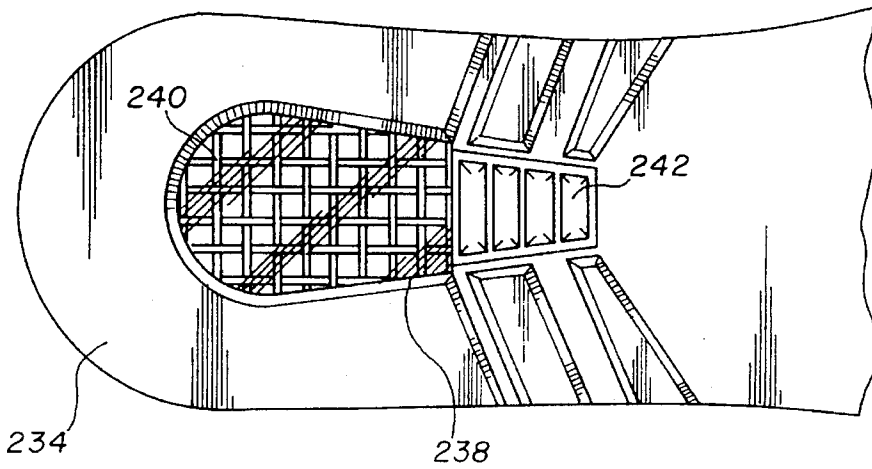

FIG. 30

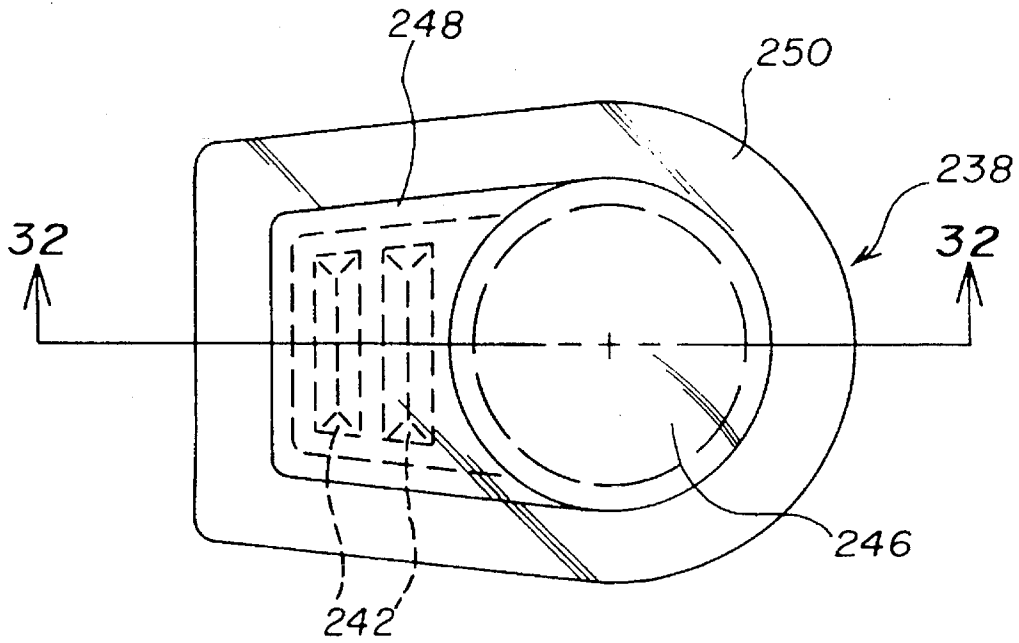

FIG. 31

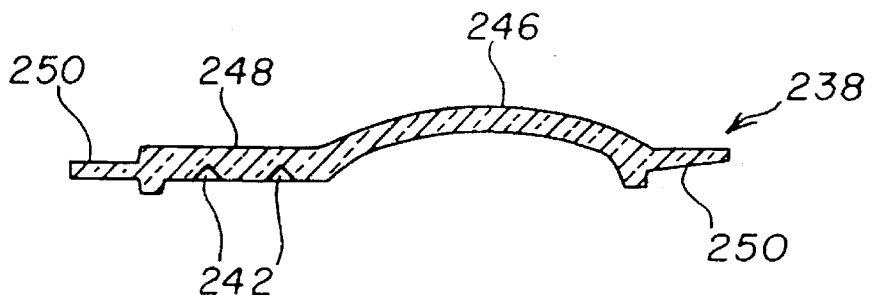

FIG. 32

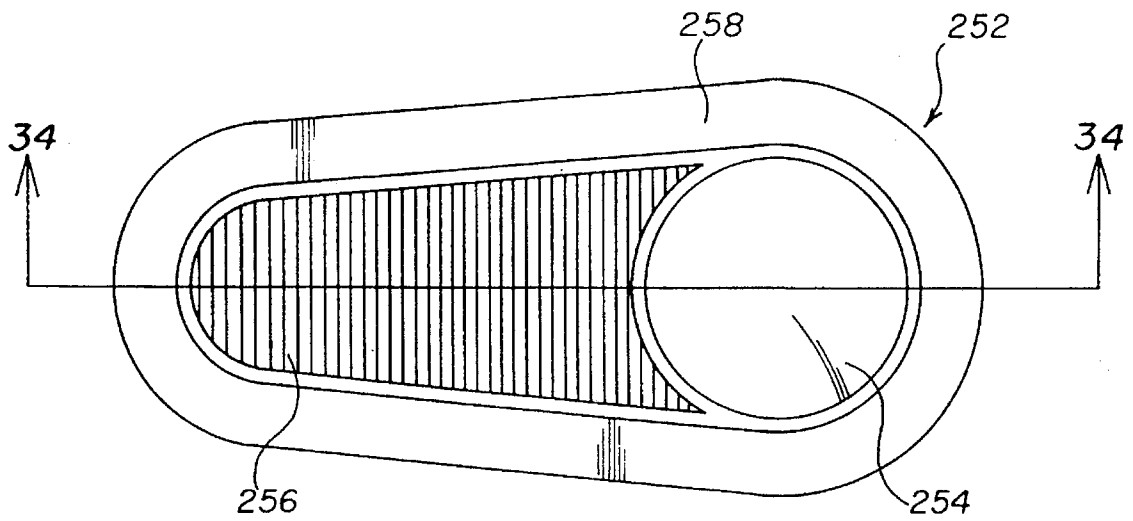

FIG. 33

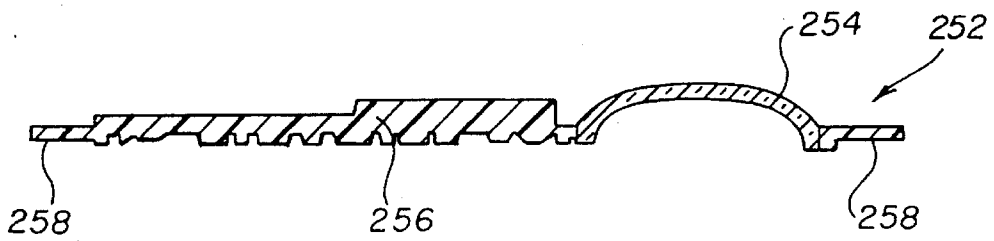

FIG. 34

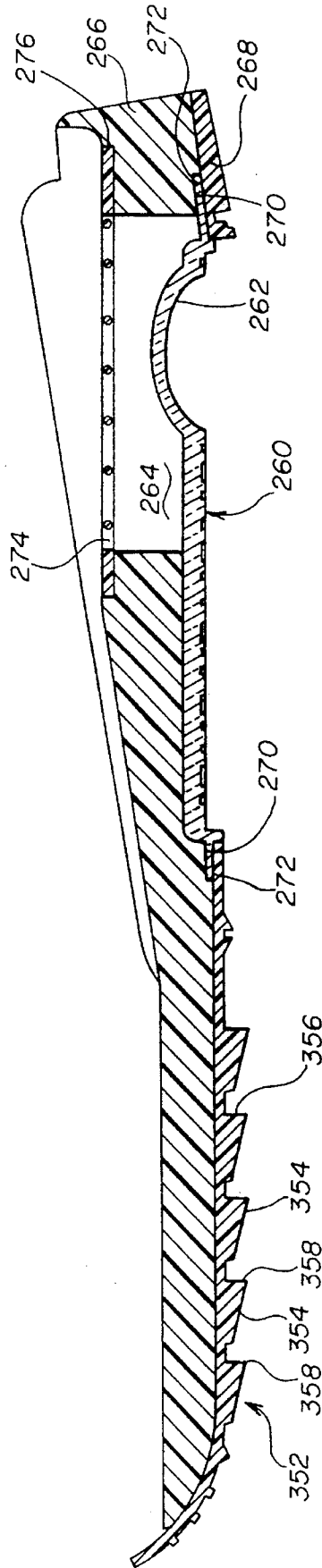
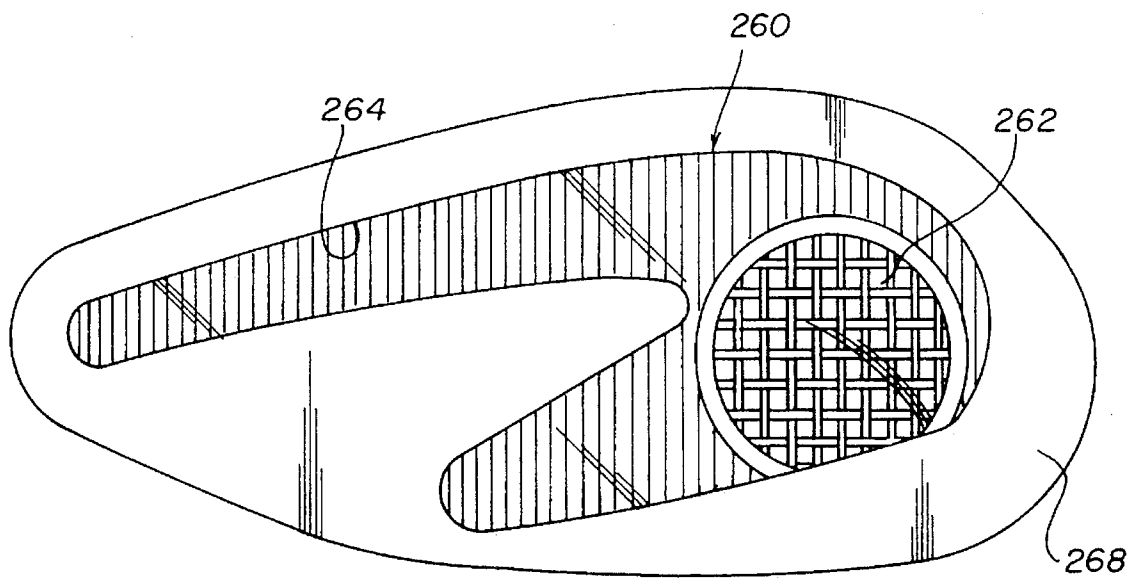

FIG. 35





**FIG. 36**

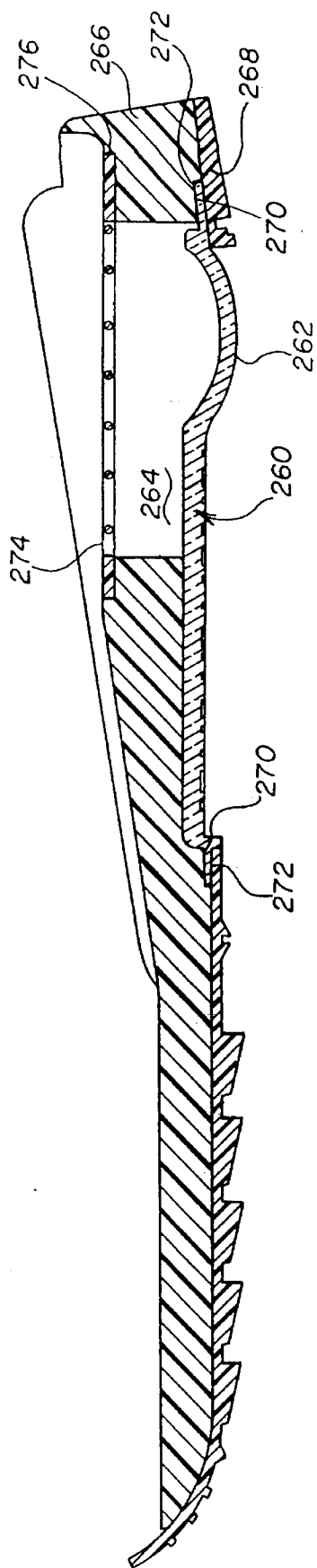
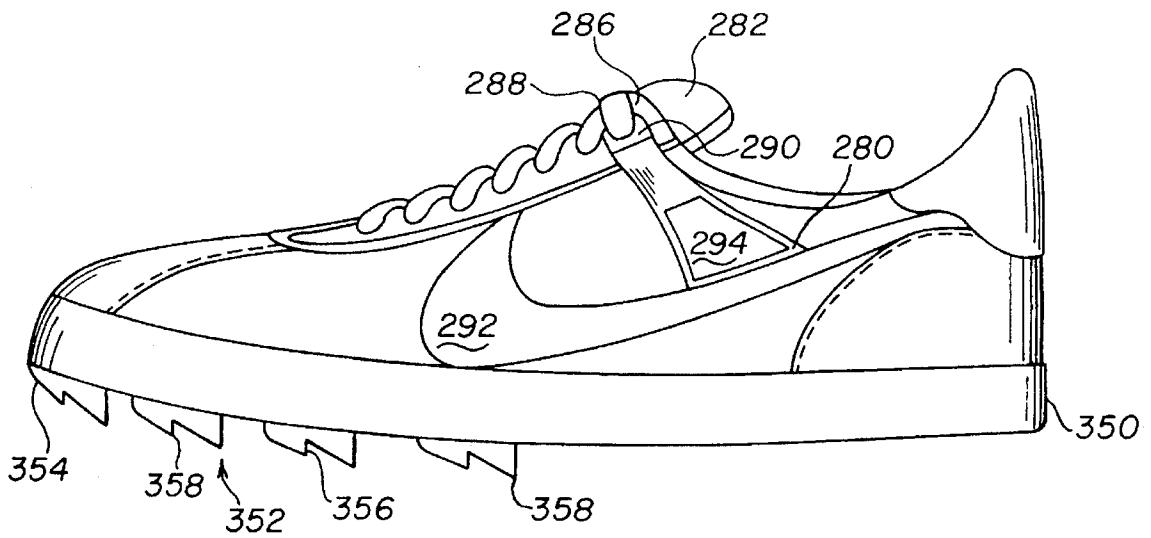

FIG. 37



**FIG. 38**

## SHOE CONSTRUCTION HAVING AN ENERGY RETURN SYSTEM

This application is a continuation, of application Ser. No. 07/982,824, filed Nov. 30, 1992, abandoned, and a continuation of application Ser. No. 08/075037, filed Jun. 10, 1993 now abandoned, which is a division of application Ser. No. 07/682,690 filed on Apr. 9, 1991, now abandoned, which in turn is a continuation in part of application Ser. No. 07/427,764 filed on Oct. 26, 1989, now U.S. Pat. No. 5,070,629.

### SUBJECT MATTER OF INVENTION

The present invention relates to a shoe construction and more particularly to a shoe having means for imparting energy return characteristics to the shoe.

### BACKGROUND OF INVENTION

There has been recent interest in improving performance characteristics of athletic and walking shoes. Initially these efforts were primarily directed to improving cushioning and shock absorption. Improvement of these characteristics was materially assisted with the development of a range of synthetic materials particularly useful in footwear manufacture. Most recently, microcellular closed cell material of selected compressibilities such as ethylene vinyl acetate (EVA) and improved polyurethane systems has been used in the commercial manufacture of a variety of midsole and wedge components intended to improve the comfort, cushioning and shock absorption of footwear. Commercially available footwear using such material now include components to improve the stability and bio-mechanics of the footwear. Such components as motion control devices and torsional rigidity bars are also now common components in such commercial products.

The most recent industry interest relates to the manufacture of footwear having energy return characteristics. This interest has also been enhanced by the common availability of EVA and other microcellular foam materials for use as resilient cushioning material. Such material has the characteristic of absorbing energy in the compression phase of a gait cycle and releasing the energy as the compression is released. The absorbed energy is released in the push-off phase of the gait cycle in running or walking.

Other energy return systems have contemplated the use of thermoplastic hollow tubes or shapes encapsulating a fluid or gas such as a Freon. These encapsulations are strategically located in the midsole or elsewhere to provide an energy return mechanism to the shoe.

Still other systems contemplate the use of such commercially available materials as Hytrel and Kevlar in various blends, compositions and molded arrangements positioned in the arch and/or medial portion of the shoe providing mechanical cushioning and energy storage.

There has been some use of netting or mesh arrangements in selected portions of a sole construction for various purposes. Insofar as the applicant is aware, the earliest of such efforts was in the form of a fine woven wire fabric described in U.S. Pat. No. 812,496 issued Feb. 13, 1906. Mesh used in that construction, however, provided only stiffness and wearing qualities at the bottom of the heel. That patent failed to suggest arranging the mesh under appropriate tension and thus fails to teach or suggest the use of such mesh in an energy return system.

A second disclosure of a mesh construction is contained in U.S. Pat. No. 1,650,466 issued Nov. 22, 1927. In that construction, a fabric of mesh is used to retain the shape of a component and does to act as an energy return system such as a spring or the like.

Most recently, U.S. Pat. No. 4,297,796 issued Nov. 3, 1981, discloses the use of an open work support or netting of stretch resistant threads secured to the top side of a flexibly deformable sole layer. This netting structure is intended to distribute shock stresses in the heel or ball of the foot. Since that open mesh is three-dimensional, it redistributes deformation of the sole structure under compression and does not function as a spring-like energy return system.

Similarly, a more recent disclosure in U.S. Pat. No. 4,608,768 issued Sep. 2, 1986 discloses the use of an open work structure embedded in a resilient member with plugs arranged within the openings of the open-work structure. In such an arrangement, different shock absorbing characteristics may be imparted to selected portions of the sole structure. The mesh arrangement, itself, however does not appear to be used as a spring-like energy return system.

Other references in which various midsole structures having related arrangements include, U.S. Pat. Nos. 3,808,713, 4,179,826, 4,263,728, 4,451,994, 4,507,879, 4,566,206, 4,753,021, and 4,774,774.

Insofar as the applicant is aware, no efforts have been made to use a mesh or net-like structure as a means for imparting energy return characteristics in footwear. Prior efforts directed toward energy return systems have, insofar as the applicant is aware, centered upon the use of macro and microcellular structures in which energy is stored in a fluid system under compression and thereafter released during expansion of the fluid component. Such arrangements have a variety of limitations. Nor is applicant aware of using a mesh-like arrangement in combination with a frame shaped to provide added functions and features including cushioning and stability.

### SUMMARY OF INVENTION

It is an object of the present invention to provide an improved and alternate means for imparting energy return characteristics to a shoe.

A further object of the present invention is to provide an improved shoe construction particularly useful for athletic activities that incorporates a spring-like system in selected areas of the heel and forefoot portion for purposes of storing energy in running and/or jumping during compression portions of the gait cycle and for releasing energy during the push-off phase of the gait cycle.

A further object of the present invention is to provide an improved energy return system for footwear which does not require the use of currently popular gas or fluid filled tubes or chambers.

A further object of the present invention is to provide a footwear construction with energy return characteristic that may be used in a wide range of footwear, including shoes designed for walking and various sporting activities, such as running, basketball, aerobics and the like.

Another object of the present invention is to provide an improved energy return system for use in footwear constructions that can be specifically tuned to meet particular needs of individuals and particular requirements of different sporting activities.

A further object of the present invention is to provide an improved energy return system incorporated into a shoe that

reduces the weight of the shoe by eliminating portion of the midsole material.

Still another object of the present invention is to provide an energy return system for footwear which may be visibly incorporated into shoes to enhance the marketability of the footwear.

One more object of the present invention is to provide an energy return system for footwear that is readily manufactured to consistent standards.

A further object of the present invention is to provide an energy return system in which the compression set of the midsole component is minimized by shaping the system to assure the uniform distribution of forces on the components and to minimize internal friction.

Another object of the present invention is to provide an improved energy return system in the form of a mesh or net secured under tension in a plane parallel to the sole and over an open or void area in the heel and forefoot portion of the sole structure for energy storage during heel engagement and push-off in the gait cycle as well as in jumping and/or running.

One more advantage of the present invention is to provide an improved energy return system that incorporates a frame supporting mesh or net components, both in the heel and forepart region of the shoe. Such mesh or net components are maintained under tension to impart spring-like qualities which absorb energy during compression and release it during the push-off portion of the gait cycle.

A further object of the present invention is to provide an energy return system that incorporates additional features of motion control and torsional rigidity through integrally formed members of the structure.

Still another object of the present invention is to provide an energy return system for footwear which may be visibly incorporated into shoes to enhance the marketability of the footwear.

One further object of the present invention is to provide an energy return system for footwear which is visible through transparent openings in the midsole and outer sole with these openings vertically aligned.

A further object of the present invention is to provide a window through which the energy return system components may be viewed from either the bottom or top of the shoe in the heel region and in which the shape and performance of the energy return system may be tactically examined.

A still further object of the present invention is to provide a window-like opening in the outer sole of the shoe for visual inspection of an energy return system contained in the sole structure with a window-like opening including a magnifying lens to enhance and enlarge the image of the energy return system components.

Another object of the present invention is to provide a window-like opening in the shoe upper to provide for placement of a resilient mesh or insert to add strength and flexibility to the shoe.

Another object of the present invention is to provide an improved traction device located on the perimeter of the sole.

#### DETAILED DESCRIPTION OF DRAWINGS

These and other objects and advantages of the present invention will be more clearly understood when considered in conjunction with accompanying drawings in which:

FIG. 1 is a perspective view of a rigid heel frame embodying components of the invention.

FIG. 2 is a perspective view of a heel component illustrating yet another embodiment of the invention;

FIG. 3 is a top-plan view of a heel-component illustrating another embodiment of the invention;

FIG. 4 is a cross-sectional detail taken substantially along the line 4—4 of FIG. 3, but in addition showing further components of a midsole construction;

FIG. 5 is a top-plan view of a heel component illustrating still another embodiment of this invention;

FIG. 6 is a cross-sectional of detail taken along an injection mold used in the fabrication of the embodiment illustrated in FIG. 5;

FIG. 7 is an end view of a midsole construction schematically illustrating components of the invention;

FIG. 8 is a cross-sectional view of a further modification similar in some respects to FIG. 1, the cross-section taken longitudinally of the unit;

FIG. 9 is a perspective view of a midsole construction embodying features of the invention with portions in dotted outlines;

FIG. 10 is a top-plan view of the embodiment of FIG. 9;

FIG. 11 is a side-elevational view of the embodiment of FIGS. 9 and 10.

FIG. 12 is a cross-sectional detail taken along line 5—5 of FIG. 11;

FIG. 13 is a perspective view of a heel component illustrating another embodiment of the invention;

FIG. 14 is a top-plan view of a heel component partially assembled illustrating still another embodiment of the invention;

FIG. 15 is a cross-sectional detail taken along the line 15—15 of FIG. 14;

FIG. 16 is a top-plan view of a component of the invention primarily located in the metatarsal region of the midsole with the midsole shown partially in dotted outlines;

FIG. 17 is a plan-view of a modification of the embodiment shown in FIG. 16;

FIG. 18 is a top-plan view of a frame construction illustrating components of the invention in the heel, midfoot and metatarsal region of a midsole.

FIG. 19 is a side-elevational view of the embodiment of FIG. 18;

FIG. 20 is a top-plan view of still another embodiment of the present invention in a midsole construction primarily useful for court type activities;

FIG. 21 is a side-elevational view of the embodiment of FIG. 20;

FIG. 22 is a cross sectional view taken substantially along the line 22—22 of FIG. 21;

FIG. 23 is a fragmentary cross-sectional view of a midsole illustrating a modification in the heel region of the midsole;

FIG. 24 is a perspective view illustrating still another embodiment of the invention;

FIG. 25 is a fragmentary detail illustrating a method of knotting or tying components of the present invention;

FIG. 26 is an enlarged detail showing a locking mechanism for components of the present invention;

FIG. 27 is a side-elevational view of a midsole illustrating another embodiment of the invention intended for use with a torsional rigid bar in the midfoot region;

FIG. 28 is a top-plan view of one of the components illustrated in FIG. 27; and

FIG. 29 is a cross-sectional view of a heel component illustrating an embodiment of the window insert of the invention;

FIG. 30 is a bottom view of FIG. 29;

FIG. 31 is a top plan view illustrating an embodiment of the insert of the invention;

FIG. 32 is a cross-sectional view of the insert of FIG. 31 taken along line 32—32;

FIG. 33 is a top plan view illustrating another embodiment of the insert of the invention;

FIG. 34 is a cross-sectional view of a heel component illustrating the embodiment of the invention taken along line 34—34 of FIG. 33;

FIG. 35 is a cross-sectional view taken along the midline of a shoe containing a sole tread and a transparent insert of the invention;

FIG. 36 is a bottom view illustrating yet another embodiment of the insert of the invention;

FIG. 37 is a cross-sectional view taken through the axis of a shoe, similar to that of FIG. 35, illustrating yet another embodiment of the insert of the invention;

FIG. 38 is a side view of a sole tread and shoe upper reinforcing overlay of the invention.

#### DETAILED DESCRIPTION OF THE INVENTION

The energy return system of the present invention includes the use of components in the midsole region which provide both cushioning and energy return characteristics. These components may also be selectively embodied in the heel, midfoot and/or forepart of the midsole as well as other areas of the shoe to achieve desired energy return characteristics designed for a particular type of shoe. Thus components may be especially designed for use in walking shoes or various specific types of athletic shoes such as basketball or running shoes.

##### A. Heel Insert

Referring first to the embodiment illustrated in FIG. 1, there is illustrated a rigid frame 1 designed to be incorporated in a midsole construction. This rigid frame 1 is shaped to fit in the heel region of the shoe preferably above and permanently secured to a midsole member (not shown). The frame 1 is a stabilizing member having an upwardly extending flange or sidewall 2 about its periphery from the lateral side, extending about the heel forwardly to the forward portion of the heel on the medial side at the arch area 3. The upwardly extending flange 2 has a greater height along a length 4 at its forward ends defining motion control device that is intended to impart greater stability to the heel. An inwardly extending flange 5 is continuous with the lower

edge of the upwardly extending flange 2, defining an open area 6. The forward end of the open area 6 is defined by a lateral flange 7 which is continuous with the forward ends of flange 5. A plurality of fibers 8 and 9, which may be of nylon or other suitable filaments used for tennis racquets, are woven into a grid or net positioned in the plane of the flanges 5 and 7. The fibers 8 and 9 have their respective ends anchored and suitably locked into the flanges 5 and 7 so that the grid or net 10 is taut and thereby forms a spring-like member which is highly resilient. The ends of the fibers 8 and 9 may be suitably locked to the rigid frame by suitable means. For example, the fibers 8 and 9 may be enlarged, bent or knotted at the ends before being positioned in a mold from which the rigid frame is formed. The fibers should not have any slack. Alternately, the ends may be ultrasonically or otherwise welded to the frame. In this procedure the frame is formed with an upper and lower half between which is sandwiched the preassembled mesh with its ends lying in aligned grooves in the facing surfaces of the two halves. The unit is ultrasonically welded together in a suitable sequence as a sandwich. The rigid frame 1 is thus molded with the enlarged ends of the fibers 8 and 9 molded into the flanges 5 and 7 as illustrated.

The frame 1 must be made of a stiff or semi-resilient material to permit the frame and the fibers be maintained under taut conditions. Under some conditions the fibers may be maintained under tension. This frame may be compounded from a variety of plastic such as high impact thermosetting plastic or in combination with material such as commercially available Kevlar. The fibers may be formed of a reinforced material or material having significant tensile strength characteristics, such as nylon monofilament or boron or graphite composite filaments in order to achieve both characteristics of stability and shock attenuation.

In embodiments where the frame is welded to fibers as a compression-molded "sandwich", as illustrated above, the fibers are preferably made of polyester monofilament. Particularly preferred polyester fibers have a mesh count ranging from about 3.8×3.8 to about 4.5×4.5 per inch; a thread diameter ranging from about 850 to about 1400 microns, a mesh opening ranging from about 20.0×10<sup>6</sup> square microns about 31.4×10<sup>6</sup> square microns, and a tensile strength ranging from about 220 to about 600 lbs. per linear inch.

In embodiments where the frame, flanges and fibers are injection molded as a single-unit, flanges 5, 7 and mesh fibers 8, 9 can preferably be compounded from thermoplastic polyester elastomers. Particularly preferred elastomers are those made from HYTREL® (DuPont Company, Elastomers Division, Wilmington, Del. 19898). Specific HYTREL® polyester elastomers useful in this embodiment include HYTREL® 7246, HYTREL® 5526 and HYTREL® 4056. Specifications and physical characteristics of these elastomers are given in Table 1. Polyurethane (PU) or nylon with similar specifications as these HYTREL® elastomers are also suitable for use in this single-unit embodiment.

TABLE 1

Property	Units	Properties of HYTREL® Elastomers		
		HYTREL® 7246	HYTREL® 5526	HYTREL® 4056
Durometer	Points	70	55	40
Melt Flow 240°	g/10 min	12.5	18	5.3
Melting point	°C.	219	202-218	148-170
Shrinkage	mm/mm	0.012		0.003

TABLE 1-continued

Properties of HYTREL® Elastomers				
Property	Units	HYTREL® 7246	HYTREL® 5526	HYTREL® 4056
Specific Heat 60° C.	J/kg/K	1,507		
Specific Heat of Melt	J/kg/K	2092		
Heat of Fusion	J/kg	46,500		
Tensile Strength	MPa	46	40	28
Elongation at Break	%	400	500	550
Tensile Stress at Yield	MPa	27		
Elongation at Yield	%	23		
Stress at 5% Strain	MPa	14	6.9	2.3
Stress at 10% Strain	MPa	20	10.3	3.7
Flexural Modulus (22° C.)	MPa	585	207	55
Initial Tear Resistance, Die C	kN/m	200	158	101
Tear Propagation Resistance	kN/m	100		
NBS Abrasion Resistance	%	3719	3540	760
Specific Gravity	—	1.25	1.20	1.16
Water Absorption	%	0.3	0.5	0.6
Heat Distortion				
0.5 MPa	°C.	150		
1.8 MPa	°C.	50		
Softening Point, Vicat	°C.	207	180	108

The rigid frame 75 of FIG. 2 lacking flanges is similar in purpose to the rigid frame illustrated in FIG. 1. This frame 75 is formed with a plurality of filaments 76 and 77 which extend respectively laterally and transversely across the opening defined by the wall 78 of the rigid frame 75. These filaments 76 are suitably interwoven to define a web having apertures in the order of  $\pm\frac{1}{8}$  inch and provide suitable tension and tightness because their respective ends are locked into the upper surface of wall 78.

In other, preferred embodiments of the invention, the grid or mesh is integrally molded as a single unit, forming an injection molded grid or mesh cassette. This integrally molded grid 102 includes orthogonally related fibers which are integrally molded in a taut, planar relation to the peripheral and integrally formed frame 100. The grid fibers forming the cassette are easily positioned in the recess 6 made by the frame.

FIGS. 3 and 4 illustrate another embodiment of the heel component in which the rigid frame 90 is formed with an annular wall member having medial and lateral sides 91 and 92 respectively interconnected by forward and rear sides 93 and 94 respectively. These sides define an open area 95. An annular shoulder 96 is formed on the inner periphery of the sides 91 through 94. Fitted within the annular shoulder 96 and extending across the open area 95 is a molded grid 97 having a concave upper surface. The periphery of the grid 97 engages and is rigidly secured within the shoulder 96 of frame 90. The convex grid 97 is formed of a resilient material capable of deflection and return when impacted by the force of a user's foot. The rigid frame 90 may be integrally connected to a torsional rigidity bar 98 similar in construction and function to the torsional rigidity bar 26 of a previously described embodiment. See co-pending application Ser. No. 07/427,764, filed Oct. 26, 1989.

In FIG. 5 there is also illustrated a particularly preferred rigid frame 100 lacking flanges which is supported on a resilient midsole substrate, preferably formed of EVA or other microcellular compressible resilient material shown in dotted outline at 101. The frame 100 is substantially made of a grid 102 of filaments, providing a resilient support and is

suitably secured by cement or other means to the upper surface of the substrate. In this embodiment, the frame 100 including the grid 102 is formed as a unitary, injection molded cassette. The orthogonal filaments intersect to form substantially square openings of about 6 mm on a side. A cross-section of the injection-mold 102A for the filaments is shown in FIG. 6. Individual filaments 102 extending laterally are substantially round in cross-section except where they intersect orthogonal filaments (points A,B,C,D,) to form the grid. At these intersections, individual filaments are roughly semi-circular. The halves of the injection mold are joined at line E.

The frame includes a unitary peripheral flange designed to seat within a corresponding recess in the midsole (not shown here). Typically, the flange is between about 10.0 and about 12.0 mm in width and about 2 mm in depth. An opening 103 in the substrate 101 immediately below the frame 100 is defined by a wall 104. This opening permits free flexing or movement of the grid 102 downwardly into the opening 103 on normal walking, running and jumping. The midsole 101 may be formed of a resilient compressible material, such as a microcellular-filled closed cell foam, preferably a polyurethane (PU) or an ethyl vinyl acetate (EVA) material of uniform thickness from the rear of the heel to the toe of the shoe. This midsole may be preferably contoured and shaped. Thus, for example, it may be tapered from a thicker end at the heel to a thin end at the toe, as illustrated in FIG. 35. The compressibility for the midsole depends upon the particular purpose for which the shoe is designed. Thus, for example, it may have a durometer in the order of 30 to 45 Sa. Although the midsole is described as formed of a resilient compressible material of the type conventionally used for midsole constructions, its thickness and or durometer should be sufficient to maintain a void or opening 103 below the grid or net 102 when the shoe is worn. This opening 103 in the midsole beneath the grid or net has a relevant function with respect to cushioning energy return motion control. Its location also assists in stabilizing the foot during gait cycle.

In FIG. 7, there is schematically illustrated one typical location of a resilient grid or net of the type illustrated in

FIG. 5. In this arrangement, the frame **100** may be located intermediate between the upper surface **140** and the lower surface **141** of a typical midsole construction. The midsole is positioned over the outsole **142**. Also contemplated are arrangements in which the frame is positioned at the top as well as embodiments in which the frame is positioned at the bottom of the midsole.

FIG. 8 illustrates a further embodiment of the invention employed in a rigid heel frame. In this arrangement the rigid heel frame is similar in overall construction to the embodiment of FIG. 1. However, the fibers forming the grid or net are embedded in a flexible matrix. As illustrated, the frame has an upwardly extending flange or sidewall **200** about its periphery from the lateral side about the heel forwardly to the forward portion of the heel on the medial side of the arch. If desired a motion control device **201** may be incorporated into the flange **200** in the forward portion of the heel area. An inwardly extending flange **202** continuous with the lower edge of sidewall **200** defines an open area **203**. The forward end of the open area **203** is defined by a lateral flange **204**. A second component **205** similar in shape and size to the flanges **202** and **204** forms the base of the heel frame. This lower component **205** is vertically aligned with flanges **202** and **204** and has the assembly **206** secured between it and the flanges **202** and **204**. Assembly **206** is a preformed unit comprising a mesh or grid of nylon filaments **208** or other suitable material for making tennis racquets, which filaments **208** are embedded in extruded polyurethane (PU) **206B**. The filaments may be embedded by extruding PU layers under **206C** and over **206A** the filaments **208**. Thereafter individual components are die cut to form a heel shape or assembly **206**.

The sandwich forming the heel assembly is then secured by suitable means such as cementing the upper and lower components to the assembly **206**. The periphery of the assembly must be firmly secured to provide an appropriate firm support.

While this embodiment describes a unit using PU, the invention also contemplates using EVA in place of PU. In these embodiments use of EVA or PU having durometers of between Shore 25 A and about 60 A is preferable.

#### B. Instep, Forefoot and Heel Inserts

Referring to FIGS. 9 to 12 there is illustrated a midsole construction embodying features of the present invention in both the heel and forepart portion of the midsole. In this arrangement, there is provided a midsole structure having a heel assembly **15**, an instep assembly **16**, and a forefoot assembly **17**. The heel assembly **15** includes a cushion **18** of resilient compressible material such as a microcellular filled closed cell foam, preferably a polyurethane (PU) or an ethyl vinyl acetate (EVA) material of uniform thickness from the rear of the heel to the instep region. The compressibility selected for this cushion **18** depends upon the particular purpose for which the shoe is designed. Thus, for example, it may have a durometer in the order of 30 to 45 Shore A. The cushion of this midsole has secured to it the rigid heel frame **19**. This rigid heel frame **19** is preferably formed of a uniformly thick wall member defining an open area **20** within the frame **19**. The frame **19** is formed of a wall with a series of uniformly spaced slots or grooves **21** in the upper, lower, and outer surface of the frame wall. Fibers positioned in these slots **21** are arranged in two groups with one group **22** extending longitudinally of the midsole and the other group **23** extending transversely of the midsole to form a

grid or net **25** in the open area **20**. The fibers forming the groups **22** and **23** are each a filament material which may be of the type suitable for making tennis rackets. Nylon monofilaments or boron and graphite reinforced fibers are believed to be suitable for such purposes. The filaments forming each of the groups, **22**, **23**, are formed as endless fiber loops **24** which are interwoven as illustrated in FIG. 2 into net **25**, with the ends of the groups **22** and **23** positioned within opposite and aligned slots **21** that lock these groups into the positions illustrated. The rigid heel frame **19** is secured to the upper surface of the cushion **18** by conventional means such as cement.

A rigid frame of the construction illustrated in FIGS. 1, 3 and 5 is also contemplated and may be substituted for the rigid heel frame **19** in FIGS. 9 through 12.

The instep assembly **16** includes a torsional rigidity bar **26** which is essentially U-shaped in plan view as illustrated in FIG. 11 and is shaped to resist deflections normal to the plane of the fibers. One end of bar **26** comprises an upwardly extending arm **27** integrally connected at its upper end to the rigid heel frame **19** and at its lower end to a bight section **28**. The bight section **28** extends forwardly through the instep region of the midsole along the lower portion of the midsole and is continuous with an upwardly extending arm **29** at its other end. Positioned along the torsional rigidity bar **26** and extending laterally outwardly therefrom are means in the instep or arch region that provide torsional rigidity and support against pronation. Extending from the medial side **30** are a plurality of pronation resisting components. These components are each formed with a cantilever **32** having a lower end integral with and rigidly secured to the bar **26**. The end of each cantilever **32** remote from the torsional rigidity bar **26** is integrally formed with a pad **33**. As best illustrated in FIG. 10, the pads **33** which function as torsion rigidity bars are shaped to conform with the outline of the midsole construction, with the foremost pad **33** projecting slightly beyond the rearmost pads **33**. The upper surface of the pads **33** may be contoured, shaped and angled to conform with the specific upper surface of the midsole for which the shoe is being designed and may, if desired, have slightly curved or contoured upper surfaces. Other torsion rigidity bars in this combination are also contemplated.

On the lateral side of the torsional rigidity bar **26**, there is provided a lateral support system **34** which provides support or resistance against supination. In this arrangement, a plurality of cantilevers **35** are integrally formed at one end with the lateral side of the torsional rigidity bar **26**. These cantilevers **35** are aligned opposite to one each of the cantilevers **32**. The cantilevers **35** are angled downwardly with the outer ends of the cantilevers **35** having integrally formed thereon pads **36** which face downwardly and are designed to engage the upper surface of the outer sole or underlying support structure (illustrated in dotted outline in FIG. 11). The pads **36** as illustrated in FIG. 9 may be appropriately contoured and shaped to conform with the lateral periphery of the midsole construction.

The torsional rigidity bar **26** and its connected cantilevers **32** and **35** and their associated pads **33** and **36** are all preferably integrally formed of a single piece of material suitable to impart torsional rigidity, stiffness and resilience to the structure of the shoe. The assembly may be formed of an appropriately molded plastic or metal.

The forefoot assembly **17** comprises a rigid or relatively stiff annular frame **37** preferably formed of the same material of which the torsional rigidity bar is formed, and similar to the rigid heel frame, is integrally formed with the inter-



mediate torsional rigidity bar **26**. This rigid annular frame **37** comprises a flange having a width preferably similar to the width of the rigid heel frame **19** and having a shape with sides conforming to the outline of the midsole construction. The forward wall **38** of the frame **37** preferably extends across the midsole construction in the toe region while the rear wall **39** of the frame is angled from the side walls **40** to a common juncture with the upwardly extending arm **29** of the bar **26**. An open volume or area **41** defined by the walls **38**, **39** and **40** has a plurality of fibers **42** extending laterally across the sole's structure to resiliently support the forefoot of the shoe wearer. Alternately, additional fibers (not shown) may be arranged orthogonally to fibers **42**. These fibers **42** are preferably secured parallel to one another. The fibers should have a tensile strength and be spaced sufficiently close together to provide the desired resilient spring-like support for the weight of the user under dynamic conditions. These fibers may be in the order of  $\frac{1}{8}$  to  $\frac{1}{4}$  inch apart in a typical application. The fibers are suitably anchored at their ends to the side walls **40** to assume that they are maintained under tension. The heel, instep and forefoot assemblies **15**, **16** and **17** may, as previously noted, be integrally formed in a single injection molding step to provide an integrated system for imparting motion control stability against pronation or supination and cushioning during normal gait and running under various conditions. The assemblies **15**, **16** and **17** may be incorporated into a midsole shown in outline form **43** in FIG. **10** with an outer sole **46** also shown in dotted outline in FIG. **11**.

An alternate rigid frame is illustrated in FIG. **13**. This rigid frame may be formed of the same materials as rigid frame **1** (FIG. **1**) and may be used in the same assembly as described with respect to heel assembly **15** in connection with FIGS. **9** through **12**. The rigid frame is formed with annular wall **50** having opposite sides **52** and **53** a forward side **54** and a curved side **55** conforming with the contour of the heel. An elongated fiber or monofilament **51**, made of suitable material such as gut or nylon, may be strung and woven as illustrated in FIG. **13** with a series of cross filaments **56** interwoven with longitudinally extending filaments **57**. The monofilament **51** is appropriately anchored by suitable means at one location and then woven around the parallel projecting bosses **58** which extend upwardly from the upper surface of the rigid frame **50** providing suitable end supports for the fiber. These bosses **58** are generally similar in construction except for bosses **59** which define corners in a series of bosses and permit the transition of the monofilament **51** from a lateral to a longitudinal direction. The frame is also provided with a pair of shoulders **60** that project from the surface of the frame to form a uniform smooth upper surface adapted to support a lining or insole construction. The frame may be secured to underlying support in the midsole as illustrated in FIGS. **9** or **11** by suitable means such as cement or the like.

The rigid frame of FIG. **2** is similar in purpose to the rigid frame illustrated in FIG. **13**. This frame **75**, however, is formed with a plurality of filaments **76** and **77** which extend respectively laterally and transversely across the opening defined by the wall **78** of the rigid frame **75**. These filaments **76** are suitably interwoven to define a web having apertures in the order of  $\pm\frac{1}{2}$  inch and provide suitable tension and tightness because their respective ends are locked into the upper surface of wall **78**.

The embodiment illustrated in FIGS. **14** and **15** is intended to provide a function similar to the embodiments of FIGS. **12** and **13**. In this embodiment, the heel component is formed with a rigid annular frame **80** shaped, as previously

described, to be secured to the upper surface of a midsole construction at the heel portion over an opening aligned with and shaped similar to the opening defined by the annular frame **80**. The rigid frame is formed with a series of bosses **81** projecting upwardly from the upper surface of the frame. The bosses **81** are each formed, as illustrated in FIG. **15**, with a shank **82** and enlarged head **83** at uniform distances about and extending upwardly from the frame **80**. Stretched over opposite pairs of aligned bosses **81** are a series of fibers, preferably monofilaments **84**, formed with loops **85** at their respective ends. These loops **85** are shaped, sized and located to snap over opposite bosses **81** and are secured with the individual monofilaments **84** under longitudinal tension. The network of monofilaments **84** form a spring-like resilient grid or network. If desired, instead of using a monofilament **84** with integrally formed loops **85** at each end, as partially illustrated in FIG. **14**, the filaments may be formed as endless loops **86** adapted to snap over and engage adjacent bosses **81** as also illustrated in FIG. **14**.

Turning now to FIG. **16**, there is illustrated a rigid frame **105** designed to be positioned over a substrate of an EVA, PU or other material having the configuration of a midsole and partially illustrated in a dotted outline at **106**. The frame **105** is formed as a rigid member using material of the type previously described. This frame **105** is divided with two openings, including a medial opening **107** and a lateral opening **108**. These openings **107** and **108** are defined by the peripheral wall **109** and from one another by a cross-wall **110**. Nets **111** and **112** of monofilaments or fibers, formed as previously described, are suitably anchored under tension within the openings **107** and **108**. These nets **111** and **112** are strung with the filaments across the openings **107** and **108** under different degrees of tensioning, so that greater tension may be effected on one side over the other to achieve selected performance characteristics, related to midfoot for pronation and supination. Ordinarily the net under the lateral side may be under greater tension.

A similar arrangement to that illustrated in FIG. **16** is illustrated in FIG. **17**. Here a plurality of individual, relatively rigid frames **115**, **116** and **117** having durometers of 25 Shore A to 60 Shore A in hardness are shaped and positioned sequentially from the midstep region **118** toward the toe region **119** of the midsole construction. These relatively rigid frames **115**, **116** and **117** are secured to a midsole structure of the type previously described and illustrated in dotted outline at **120**, by forming the forefoot support system in a plurality of frames adjacent one another. Selective string tensions for different performance characteristics may be achieved, depending upon the particular purpose of the shoe into which the system is placed and the different purpose for which the shoe is to be used.

The frame may have a configuration generally outlined in FIG. **18** and FIG. **19**. In this arrangement, the frame **145** is formed with a heel assembly **146**, torsional rigidity bar **147**, and forefoot assembly **148**. This relatively rigid frame should be formed of material adequate to permit the grid or net **149** of filaments to be secured under tension within the open area **150** defined by the continuous side wall **151** of the frame **145** to form a heel section. Suitable means may be employed for securing the net **149** under tension. The tension should be sufficient in this embodiment, as well as in other embodiments, to support the weight of a person wearing the shoe under normal static and dynamic conditions with minimal deflection of the net or grid. The deflection under such conditions should not be greater than the depth of the open space below the open area **150**. The rigid frame **145** also secures a plurality of fibers **152** substantially

parallel to one another in the forefoot region of the foot. These fibers extend across the continuous side wall **153** which defines an open area **154** from the forward portion of the arch to the rear portion of the toe region. The fibers **152** are tensioned in a fashion similar to the tensioning of the fibers forming the grid **149** and provide similar support for the forefoot portion of the wearer's foot. The torsional rigidity bar **147** is continuous with and interconnects the continuous side walls **151** and **153**.

As illustrated in FIG. **19**, the forefoot assembly **148** has preferably a concave contour. This arrangement may be partially sandwiched or encapsulated in a resilient compressible material such as EVA or PU forming the balance of the midsole structure. This encapsulating EVA/PU includes a heel section **156**, an instep section **157** and a forefoot section **158** with the forefoot section extending above and below the frame, but with openings in sections **156** and **158** below the grid **149** and fibers **152**. Additionally, a series of lugs **159** may be formed about the periphery of sections **156** and **158**. A motion control device in the form of upwardly extending flanges **160** may be integrally formed on the frame **145** on the medial and lateral portions of the heel assembly **146**.

FIGS. **20** through **23** illustrate an embodiment particularly useful for basketball and similar sports. In this arrangement, a midsole **165** is formed of a molded core **166**, heel assembly **167** and forefoot assembly **168**. This midsole assembly may be integrally formed with components of an outer sole including a toe **169** and heel **170** formed of relatively non-compressible synthetic rubber sole material. The core **166** of the midsole is preferably formed of a microcellular material such as EVA having a density consistent with the densities normally used for midsoles of basketball or tennis court type shoes. The heel assembly **167**, integrally formed with the molded core, is made of a relatively stiff and non-yielding material such as a high impact plastic having sufficient rigidity and structural strength to support and secure the grid or net **171** under significant tension. This grid or net **171** is formed of a plurality of fibers **172** extending laterally and longitudinally of the heel assembly **167** in an interwoven arrangement with the ends of the fibers **172** appropriately locked into the continuous side wall **173**. A motion control device is formed by an upwardly extending wall **174** which is continuous with the horizontal continuous side wall **173**. The wall **174** extends upwardly about the medial, lateral and rear portion of the heel, thereby forming a cup to receive the wearer's heel. The forward end of the wall **174** is continuous with downwardly extending flanges **175** on either side of the heel assembly **167**. These flanges **175** fit closely to and engage the core **166** at its sides thereby reinforcing the assembly. The fibers **172** forming the grid **171** are positioned over an open area **176** (FIG. **23**), which permits the grid **171** to freely deflect downwardly into an open space on the application of forces when the wearer stands on the grid. The tensions on the fibers of the grid is sufficient to limit downward deflection to a point within the open area under normal use conditions.

The forefoot assembly **168** includes a series of relatively rigid frame bars **177** that include a horizontal section **178** with parallel opposed upwardly extending ends **179** and **180**. These bars **177** are rigid and essentially non-yielding and each supports a filament or fiber **181** at its end under tension. A plurality of these bars **177** are spaced closely to one another in the forefoot assembly **168** preferably from a position just forward of the instep to a position where the toe region begins. In the embodiment illustrated in FIG. **19** thirteen such bars **177** are illustrated in spaced relation. However, more or less may be used depending upon the

specific structure and purpose of the shoe design. These bars **177** are secured by molding them into the midsole core **166**. If desired, the midsole core may be provided with upwardly extending flanges along the medial and lateral portions of the shoe as illustrated at **182** with the upwardly extending flange designed to be permanently secured to the upper of the shoe (not shown) by conventional means. Additionally, an insole and/or sock lining may be provided over the assembly and an outer sole and heel construction may be attached to the lower surface of the core assembly **166** by conventional means.

The embodiment illustrated in FIGS. **20** through **23**, as noted, is designed for basketball or like usage. The individual rigid frame bars **177** arranged in spaced relation permit forefoot flexibility while at the same time provide tension, torsional rigidity and stability.

FIGS. **24** and **25** illustrate additional means for securing a monofilament **195** under tension. In this arrangement, a rigid heel frame **196** is formed with aligned holes on both the medial and lateral side of the frame. The frame **196** may take a variety of forms or shapes intended to conform with the heel of the particular shoe for which it is designed. Intermediate the upper and lower surfaces of the frame are a plurality of holes arranged in pairs **197** with each pair aligned with a like pair of the opposite side of the frame. The filament **195** is threaded back and forth through these holes and is knotted (not shown) at its free ends with the filament maintained under tension. In order to protect the filament against abrasion, the adjacent holes in each pair may be connected by a channel or groove **198** within which a section of the filament **195** will lie. This assembly may be supported on or intermediate a midsole structure.

In FIG. **25**, a similar threading arrangement is illustrated for other component sections of a shoe. In this arrangement, the side frame members **199** may form the forefoot portion of a shoe. The frame **199** may be similarly formed with longitudinally extending grooves **211** that connect a series of holes **212** through which the filament **195** is threaded. Here, the fiber is also knotted or otherwise locked at its end to provide tension of the filament sections that are intermediate the frames.

In FIG. **26**, there is shown one means for locking the fiber into a typical frame section **213**. In this arrangement, the frame **213** may be formed with a hole **214** extending through the wall of the frame. Preferably, the hole has a conic shape with a larger diameter on the outside **207** of the frame. The fiber or filament **229** extends through the hole **214** and through a sleeve **209** which is tapered and has essentially a conic configuration. The sleeve **209** has a narrow diameter **210** which is somewhat smaller than the normal diameter of the filament **229** thus forming a crimp at the inner end of the hole **214**. The sleeve **209** is made of a somewhat resilient material such as to permit the filament **229** to be threaded through the sleeve **209** from its wider diameter to its narrower diameter. However, upon application of a force away from the inner wall which places the filament **229** under tension, the filament **229** will frictionally engage and bind at the narrow diameter **210** of sleeve **209**.

The embodiment illustrated in FIGS. **27** and **28** includes a frame **215** having integrally formed heel section **216** and instep or arch section **217**. The heel section **216** is formed of a continuous wall **218** defining an open area **219**. A net or mesh **220** is stretched under tension across the open area with the ends of the individual filaments **221** that form the mesh suitably anchored in the side walls **218** to form a resilient shock absorbing cushion that imparts energy return

to forces applied to the net 220. The filament 221 may be suitably secured in the wall 218 by means previously discussed.

The heel section 216 is continuous with the instep section 217, and preferably is integrally formed with it. As illustrated the instep section is formed with a pair of forwardly projecting bars 222 and 223 respectively on the medial and lateral sides of the shoe construction. The bars 222 and 223 are upwardly offset from the heel section 216 by an integral web 224. The component illustrated in FIG. 28 is integrally molded into a midsole construction that includes a micro-cellular foam body having a heel section 225, a midfoot section 226 and a forefoot section 227 appropriately shaped to conform with the sole of the shoe, as illustrated in FIG. 27. An opening 228, illustrated in dotted outline, in the heel section 225 below the net 220 permits downward unrestrained deflection of the center of net 220.

### C. "Window" Inserts

Referring again to FIG. 29, a frame 231 and grid 240 are positioned over a midsole 232 having an opening in vertical alignment with the grid. The shape of the opening may vary depending upon the particular design characteristics desired in the shoe. Typically, the shape is roughly a truncated tear-drop shape having dimensions about 60 mm long by about 30 mm wide. The size of this opening can however be varied and it preferably should be large enough to permit easy inspection of the energy return components, but not so large as to affect the mechanical operation of the unit.

As illustrated in FIG. 29 the lower surface 230 of the midsole 232 is secured to an outer sole 234. The outer sole is also formed with an opening 236, preferably co-extensive in shape and size to the opening defined in the midsole. In the embodiment illustrated, a plastic member 238 is positioned in the opening defined by the outer sole to form an enclosed space 239 between the member 238 and a grid 240. In a preferred embodiment, the plastic member 238 has a transparent section through which the energy return components can be viewed. FIG. 30 illustrates this embodiment as a bottom view of FIG. 29, in which a section 242 of the transparent window 238 as illustrated is decorative in nature.

In a particularly preferred embodiment of the plastic member 238, illustrated in FIG. 31, the plastic member 238 is completely transparent and includes a dome-like magnifying section 246 in combination with a substantially flat elongated section 248, a portion of which may have decorative elements 242. The member is shaped to fit in the opening defined by the outer sole and includes a stabilizing flange 250 about its periphery extending from the lateral side about the heel forwardly to the forward portion of the heel on the medial side to the arch area. This continuous flange 250 is designed to fit in facing relation between an upper part of the outer sole and a lower part of the midsole. Preferably, the width of the flange is about 8 mm and its thickness is about 1 mm. The dome-like magnifying section 246 defines substantially a circular section having a radius of about 18 mm. The largest dimensions of the transparent plastic member 238, including its peripheral flange, are larger than the opening 236 defined in the midsole and outer sole. In FIG. 31, the plastic member is about 71 mm long by between about 40 mm to 50 mm wide. The member 238 is illustrated in cross section at FIG. 32. The rearward facing heel flange 250 can be tapered to about 1 mm in the heel area. The thickness of the transparent member ranges from about 1.7 mm to about 4.5 mm. The thickness of the dome-like magnifying element 246 is about 2.5 mm, as illustrated.

FIG. 33 illustrates another preferred embodiment of the plastic member, which embodiment includes sections which are not transparent. The member 252 includes a transparent, magnifying dome 254 disposed in the heel area. The dome-like section 254 is integral with an elongated section 256 that is not transparent. As described above with reference to FIG. 31, a lateral flange 258 extends completely around the periphery of the transparent and non-transparent members, which flange is approximately 8 mm in width. In the embodiment illustrated, the radius of the dome is approximately 18 mm. This embodiment is illustrated in cross section at FIG. 34. Typically, the height of the dome is about 8.5 mm. A part of the non-transparent member 256 forward of the heel dome 254 may be of varying thicknesses, as illustrated.

The relationship of these plastic inserts to the mid and outer sole is illustrated in FIG. 35 in which a plastic member 260 with an upwardly projecting and transparent dome section 262 is sandwiched between the mid sole 266 and outer sole 268 in the co-extensive opening 264 defined by both. The transparent member 262 is positioned in the outer sole opening in such a manner as to allow the member to be below the level of the outer sole. This is accomplished by providing a recess 270 in the bottom of the mid sole surrounding the outer sole opening. The peripheral flange 272 of member 260 is seated within the recess so that the outer surface of member 260 does not come into contact with the ground. A frame and/or grid cassette 274 is positioned over the midsole 266 in facing relation with the midsole. A recess 276 is provided around the outer periphery of the midsole opening so that the frame and/or grid 274 can be seated therein and secured together in permanent relation by suitable cement or the like. A section of the transparent member can be decorative in nature. If desired, the opening 264 in the outer sole 268 may be modified in the shape shown in FIG. 36.

FIG. 37 illustrates another embodiment of the invention in which a transparent member 260 is integrally secured in an opening 264 formed in the outer sole 268 and is provided with a magnifying dome-like element 262 that projects downwardly towards the ground and away from the opening formed in the outer sole. The plastic member generally is the same shape and dimensions as illustrated in the previous embodiments although in this particular illustration, positioning of the plastic member in the mid sole recess 270 is essential in order to prevent the dome from coming into contact with the ground.

Resilient inserts can also be employed to provide structural strength and flexibility to other areas of the shoe besides the heel, instep and forefoot areas, as previously described. In particular, shoe constructions of this invention contemplate use of selected grids or nets in areas of the shoe such as the vamp and/or shoe upper.

FIG. 38 illustrates a shoe having an overlay reinforcing the eyeletstay and ankle area. The overlay 280 extends longitudinally backwards from the tongue 282 to the ankle and is secured at a forward end adjacent to the eyeletstay 286 by way of lacing 288 threaded through an opening 290 in the overlay. The overlay is secured at a rearward end to a member 292 extending around the heel of the shoe. The overlay defines an opening 294 located between opposite ends of the overlay, through which the shoe material can be observed. Preferably, a plastic insert can be positioned within the opening in facing relation between the overlay and the shoe material, as illustrated in FIG. 38.

Referring again to FIGS. 35 and 38, there is depicted an athletic shoe including an upper portion of canvas, leather or

the like and laces for securing the shoe to the foot. In the preferred embodiment depicted, the outer sole **268** includes a lateral surface **350** that extends around the perimeter of the shoe. Disposed on the outer sole **268** of the shoe are plurality of traction devices **352** being substantially polyhedral in cross-section. The traction devices include substantially parallel planes **354** that are offset with respect to each other. The offset planes **354** are connected to each other by a side surface **356** that is substantially perpendicular to each of the parallel planes and to the outer sole of the shoe. The junction of the side surface and at least one of the parallel planes defines a vertex **358** that provides a gripping surface.

The sole construction of this invention is useful for athletic events and the traction devices can be made of unitary, molded rubber or of synthetic material. The hardness of the rubber as well as the shape of the traction device serves to absorb the shock produced by rugged athletic activities, making the shoe construction safer and more comfortable.

#### Equivalents

Although the specific features of the invention are shown in some drawings and not in others, this is for convenience only, as each feature may be combined with any or all of the other features in accordance with the invention.

It should be understood, however, that the foregoing description of the invention is intended merely to be illustrative thereof, that the illustrative embodiments are pre-

sented by way of example only, that other modifications, embodiments, and equivalents may be apparent to those skilled in the art without departing from its spirit.

Having thus described the invention, what we claim is:

1. A shoe construction having an outer sole, a midsole and an upper, wherein the improvement comprises:

a member formed of a molded resilient polymer comprising an outer frame defining an open center and a woven grid extending across the open center, wherein the outer frame is secured to one of said sole and midsole and the grid is integrally formed as a unit with said frame.

2. A shoe construction as set forth in claim 1, wherein the bottom surface of said grid is spaced from one of said sole and midsole to permit flexing of said grid on application of a force.

3. A shoe construction as set forth in claim 2, wherein the molded polymer is selected from the group consisting of nylon, polyurethane and thermoplastic polyester elastomer.

4. A shoe construction as set forth in claim 3, wherein the molded polymer has physical properties similar to properties of HYTREL elastomers selected from the group consisting of HYTREL 7246, HYTREL 5526, and HYTREL 4056.

\* \* \* \* \*