



US 20140109566A1

(19) **United States**

(12) **Patent Application Publication**
Ingersoll et al.

(10) **Pub. No.: US 2014/0109566 A1**
(43) **Pub. Date: Apr. 24, 2014**

(54) **METHODS AND DEVICES FOR OPTIMIZING HEAT TRANSFER WITHIN A COMPRESSION AND/OR EXPANSION DEVICE**

Publication Classification

(71) Applicant: **General Compression, Inc.**, (US)
(72) Inventors: **Eric D. Ingersoll**, Cambridge, MA (US);
Justin A. Aborn, Hingham, MA (US);
Matthew Blieske, Francistown, NH (US);
Iain Ridley, Arlington, MA (US)

(51) **Int. Cl.**
F01B 29/08 (2006.01)
F01B 31/08 (2006.01)
F04B 49/08 (2006.01)
(52) **U.S. Cl.**
CPC *F01B 29/08* (2013.01); *F04B 49/08*
(2013.01); *F01B 31/08* (2013.01)
USPC **60/512**; 417/53

(73) Assignee: **General Compression, Inc.**, Newton, MA (US)

(57) **ABSTRACT**

(21) Appl. No.: **13/887,825**

Systems, methods and devices for optimizing heat transfer within a device or system used to compress and/or expand a gas, such as air, are described herein. For example, systems, methods and devices for optimizing the heat transfer within an air compression and expansion energy storage system are described herein. A compressor and/or expander device can include one or more of various embodiments of a heat transfer element that can be disposed within an interior of a cylinder or pressure vessel used in the compression and/or expansion of a gas, such as air. Such devices can include hydraulic and/or pneumatic actuators to move a fluid (e.g., liquid or gas) within the cylinder or pressure vessel. The heat transfer element can be used to remove heat energy generated during a compression and/or expansion process.

(22) Filed: **May 6, 2013**

Related U.S. Application Data

(63) Continuation of application No. 12/977,679, filed on Dec. 23, 2010, now Pat. No. 8,454,321, which is a continuation-in-part of application No. 12/785,086, filed on May 21, 2010, now Pat. No. 8,359,857.

(60) Provisional application No. 61/216,942, filed on May 22, 2009, provisional application No. 61/290,107, filed on Dec. 24, 2009.

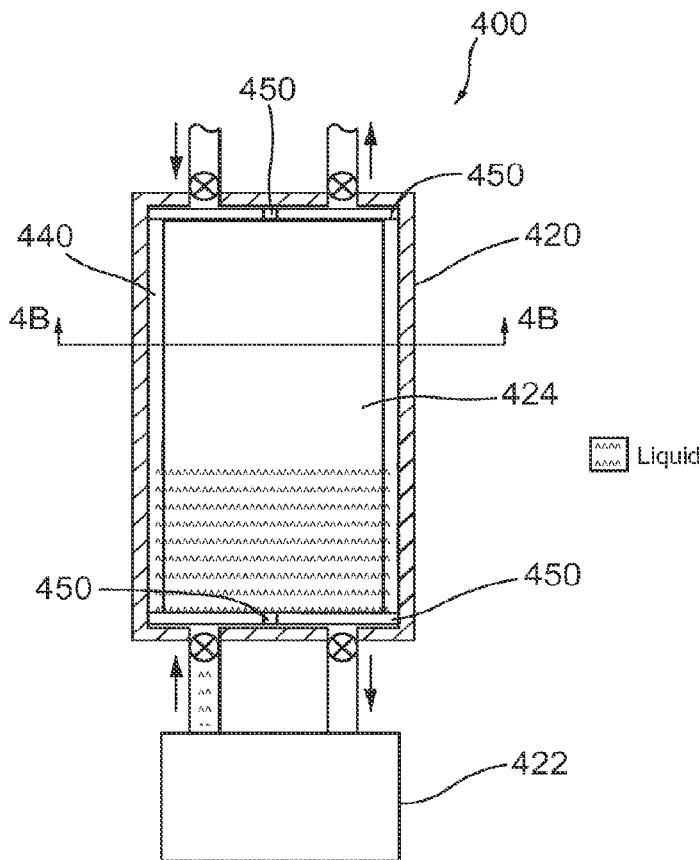

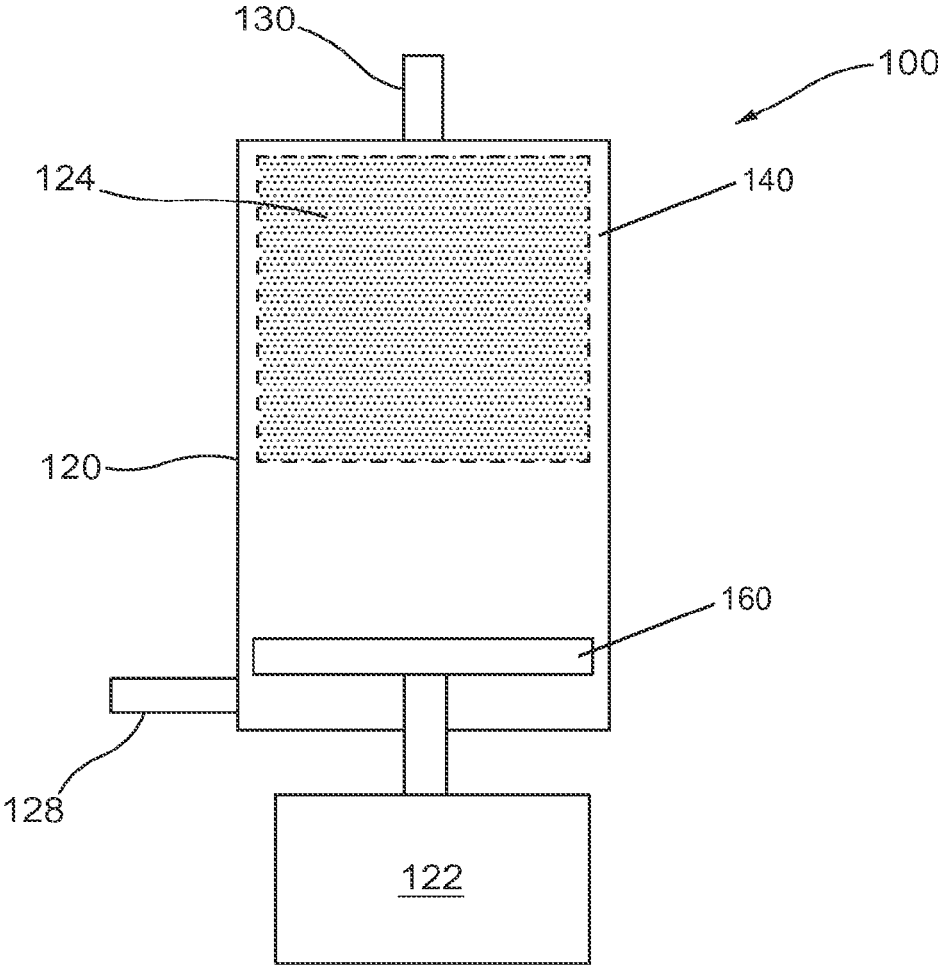

FIG. 1

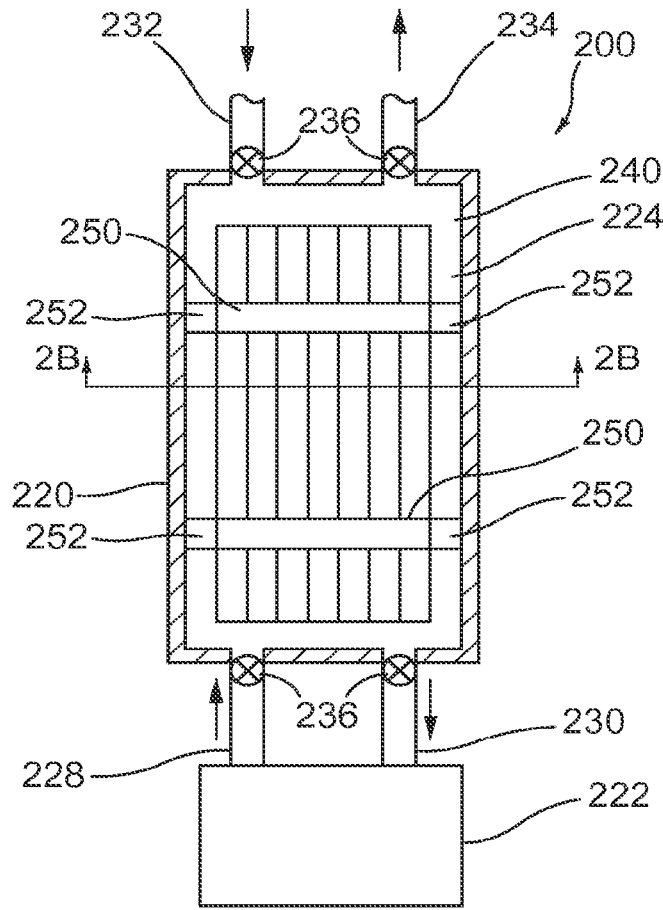

FIG. 2A

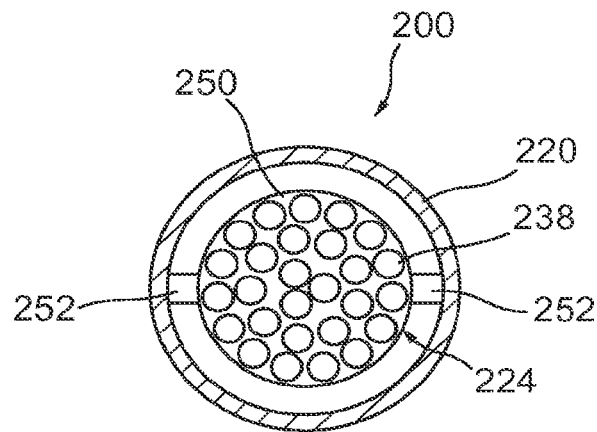

FIG. 2B

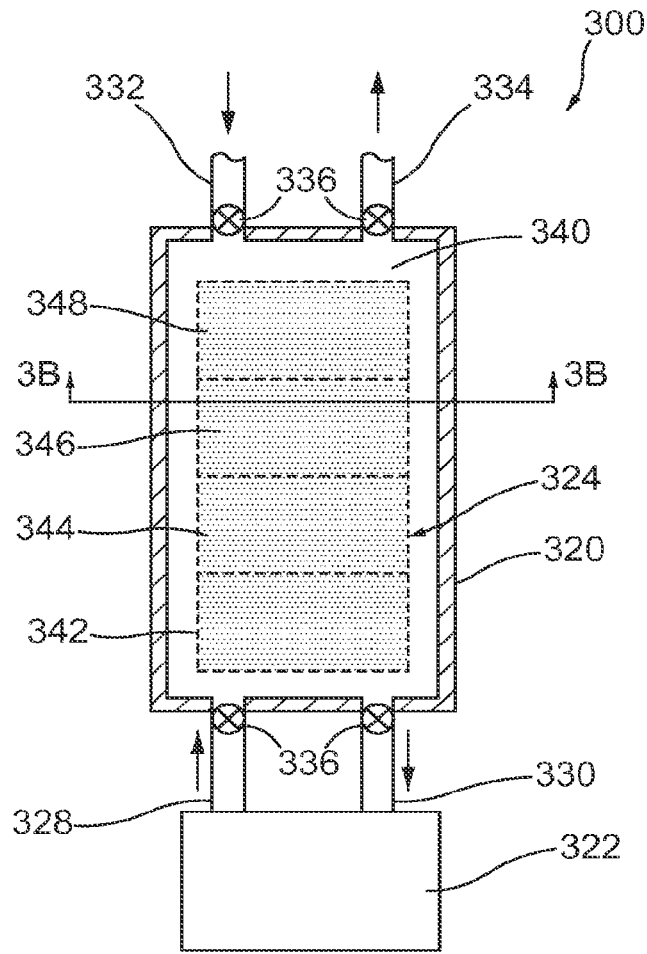

FIG. 3A

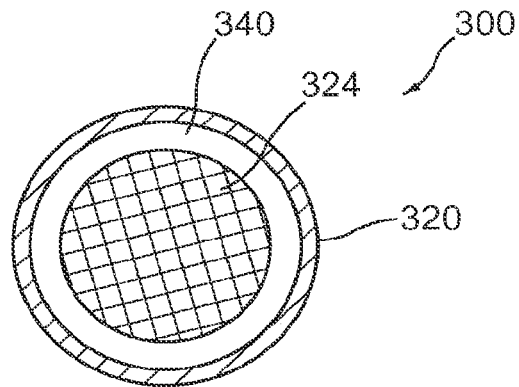

FIG. 3B

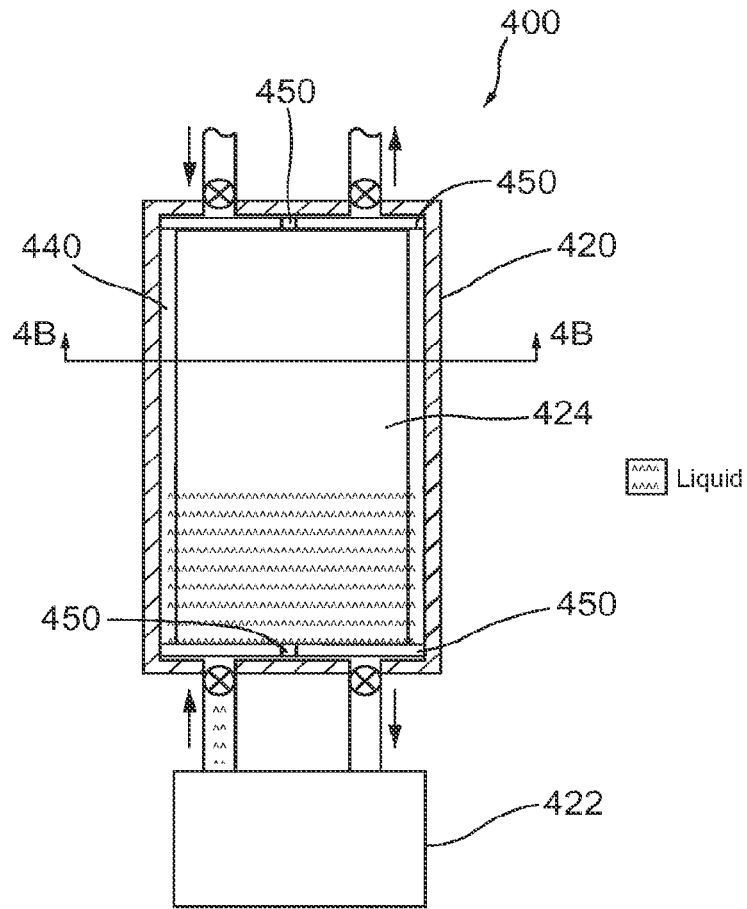

FIG. 4A

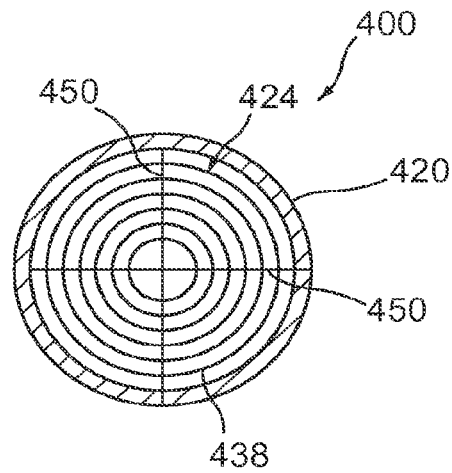

FIG. 4B

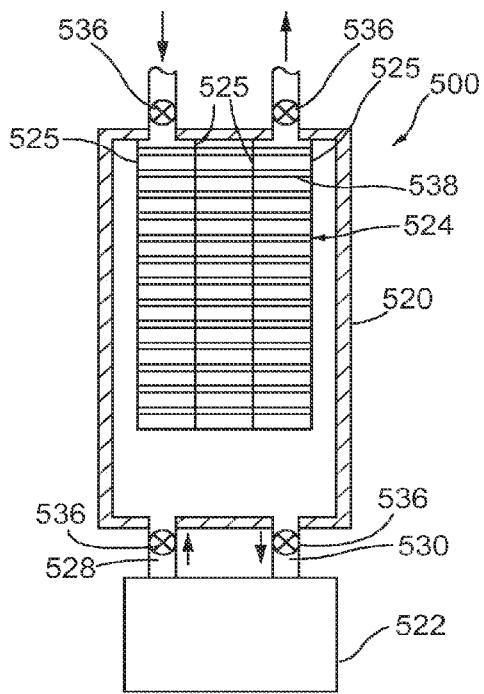

FIG. 5A

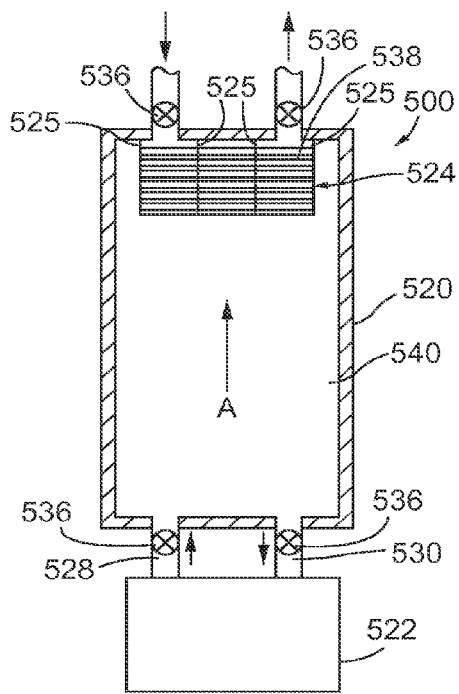

FIG. 5B

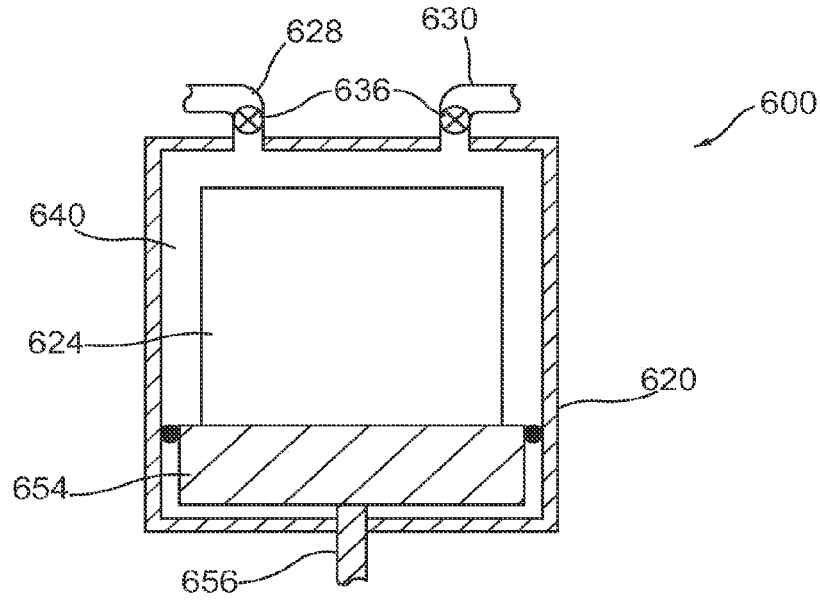

FIG. 6A

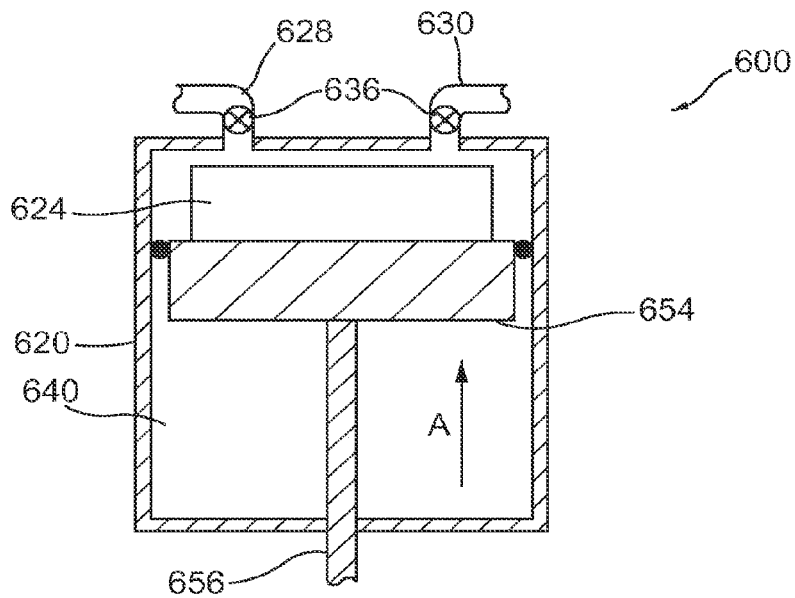

FIG. 6B

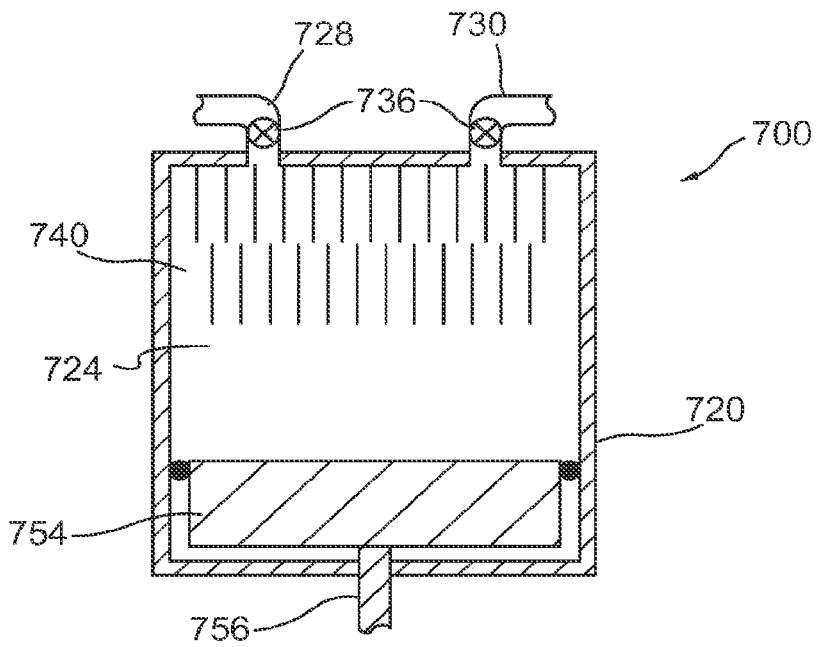

FIG. 7A

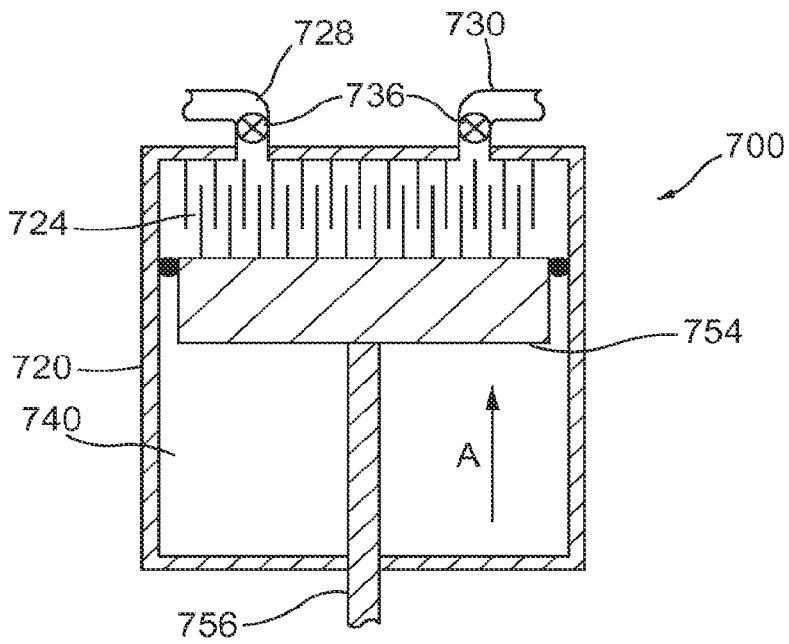

FIG. 7B

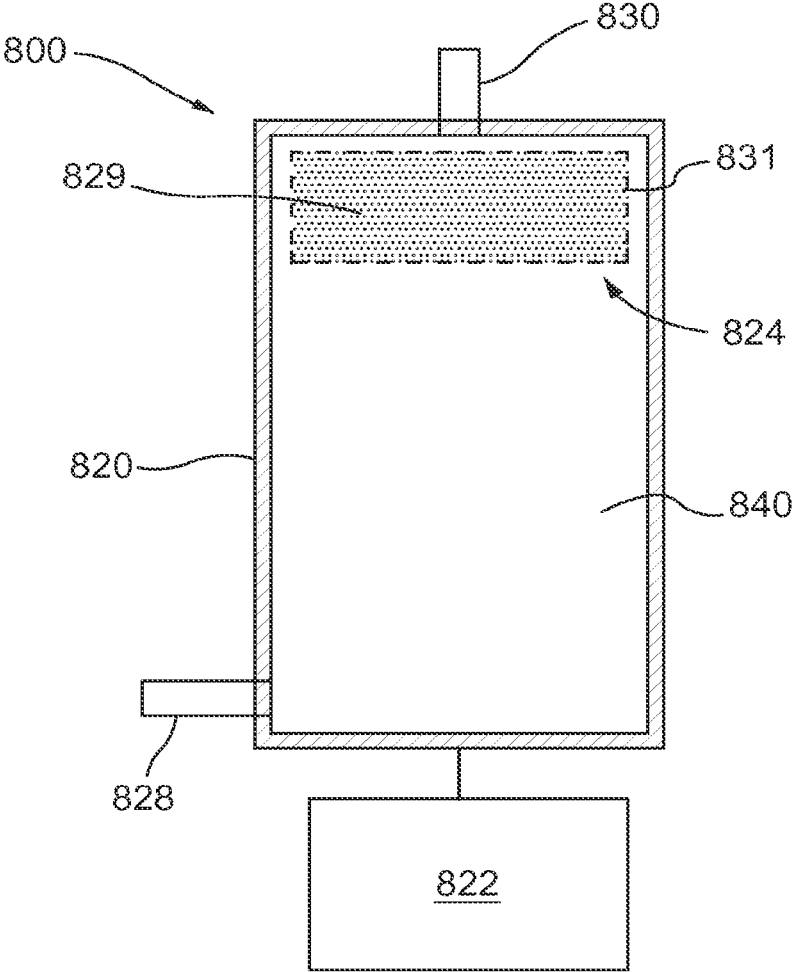

FIG. 8

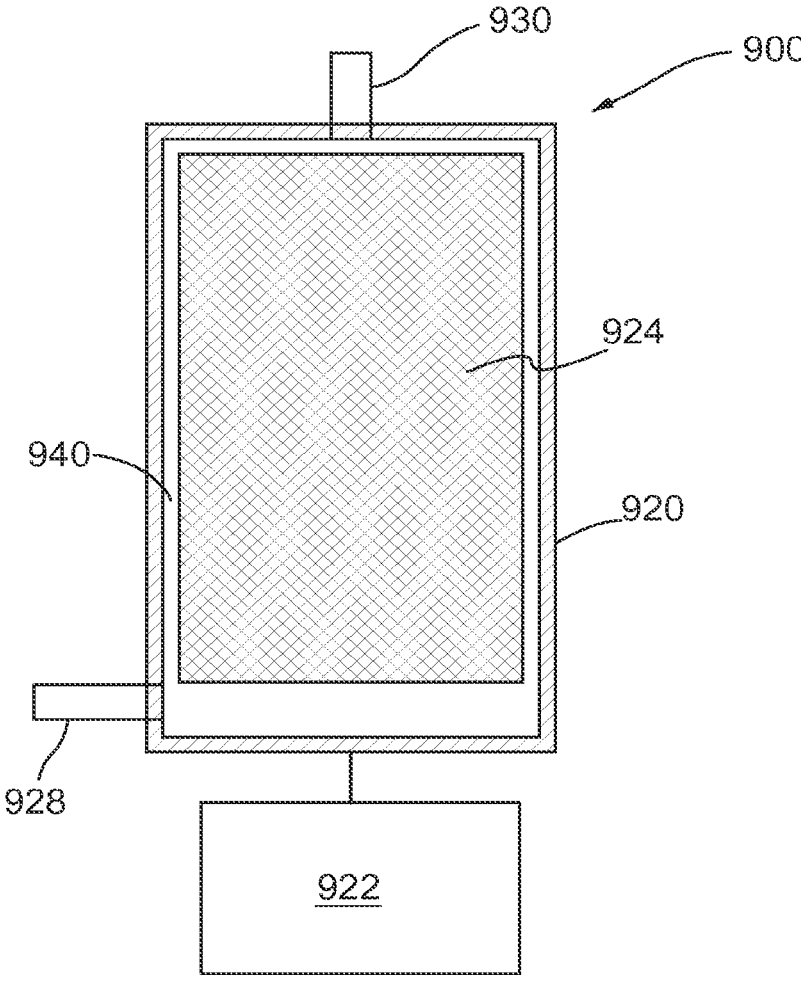

FIG. 9

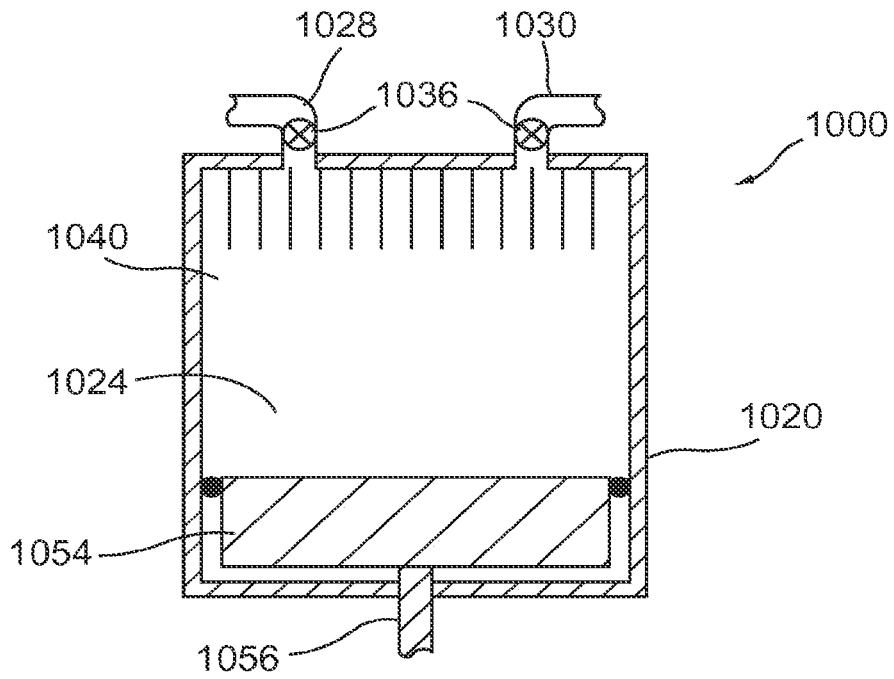

FIG. 10A

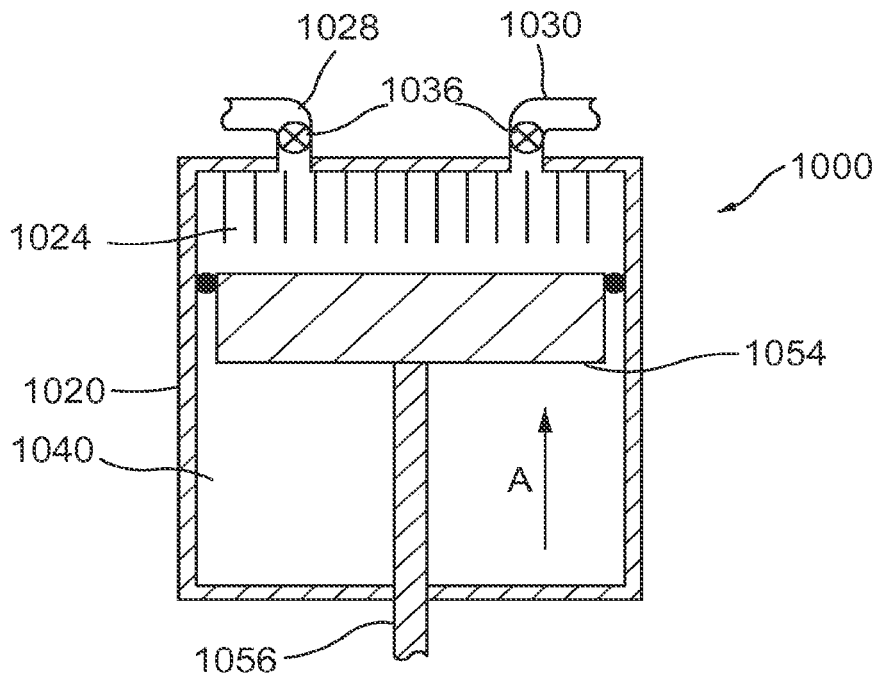

FIG. 10B

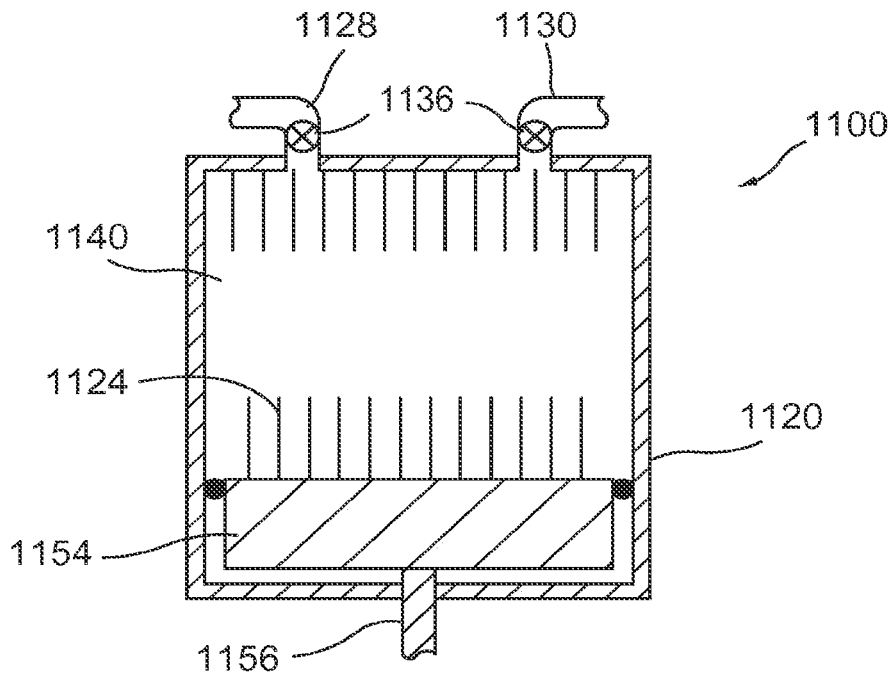

FIG. 11A

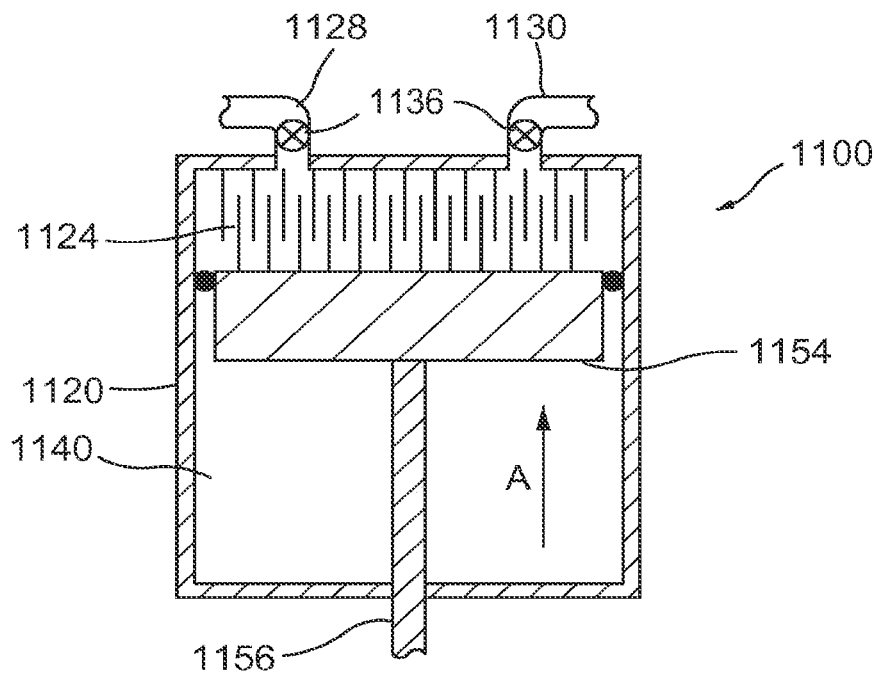

FIG. 11B

**METHODS AND DEVICES FOR OPTIMIZING
HEAT TRANSFER WITHIN A COMPRESSION
AND/OR EXPANSION DEVICE**

**CROSS REFERENCE TO RELATED
APPLICATIONS**

[0001] This application is a continuation of U.S. patent application Ser. No. 12/977,679, filed Dec. 23, 2010, entitled "Methods and Devices for Optimizing Heat Transfer within a Compression and/or Expansion Device," which is a continuation-in-part of U.S. patent application Ser. No. 12/785,086, filed May 21, 2010, entitled "Compressor and/or Expander Device", which claims priority to and the benefit of U.S. Provisional Patent Application Ser. No. 61/216,942, filed May 22, 2009, entitled "Compressor and/or Expander Device", and also claims priority to and the benefit of U.S. Provisional Patent Application Ser. No. 61/290,107, filed Dec. 24, 2009, entitled "System and Methods for Optimizing Efficiency of a Hydraulically Actuated System," the disclosures of which are hereby incorporated by reference in their entirety.

BACKGROUND

[0002] The invention relates generally to systems, devices and methods for the compression and/or expansion of a gas, such as air, and particularly to a system, device and method for optimizing heat transfer during the compression and/or expansion of a gas.

[0003] Some known devices, methods and systems used to compress and/or expand a gas, such as air, and/or to pressurize and/or pump a liquid, such as water, can be used, for example, within a compressed air energy storage system. In some compressed air devices and systems, a hydraulic actuator can be used to move or compress air within a pressure vessel. For example, an actuator can move a liquid within a pressure vessel such that the liquid compresses air in the pressure vessel.

[0004] Such known devices and systems used to compress and/or expand a gas and/or to pressurize and/or pump a liquid can change the temperature of the gas during, for example, a compression or expansion process. For example, compressing a gas can convert heat energy from its latent form into its sensible form, thereby increasing the temperature of the gas. Various heat transfer mechanisms can be used to remove heat energy during the compression process from the gas being compressed. In some known devices and systems, heat energy in the gas being compressed within a pressure vessel can also be transferred to the liquid used to compress the gas.

[0005] Thus, there is a need to improve and/or optimize the heat transfer devices and methods used to transfer heat during a compression and/or expansion process between the gas and the liquid within such devices and systems used to compress and/or expand a gas.

SUMMARY OF THE INVENTION

[0006] Systems, methods and devices for optimizing heat transfer within a device or system used to compress and/or expand a gas, such as air, are described herein. In some embodiments, a compressed air device and/or system can include an actuator such as a hydraulic actuator that can be used to compress a gas within a pressure vessel. An actuator can be actuated to move a liquid into a pressure vessel such that the liquid compresses gas within the cylinder or pressure

vessel. In such a compressor/expander device or system, during the compression and/or expansion process, heat can be transferred to the liquid used to compress the air. The compressor and/or expander process can include a heat transfer element that can be used to transfer heat energy between the gas and the liquid during a compression and/or expansion process.

BRIEF DESCRIPTION OF THE DRAWINGS

[0007] FIG. 1 is a schematic illustration of a compression and/or expansion system according to an embodiment.

[0008] FIG. 2A is a side view shown partially in cross-section of a portion of a compression and/or expansion device, according to an embodiment.

[0009] FIG. 2B is a cross-sectional view of the compression and/or expansion device of FIG. 2A, taken along line 2B-2B in FIG. 2A.

[0010] FIG. 3A is a side view shown partially in cross-section of a portion of a compression and/or expansion device, according to another embodiment.

[0011] FIG. 3B is a cross-sectional view of the compression and/or expansion device of FIG. 3A, taken along line 3B-3B in FIG. 3A.

[0012] FIG. 4A is a side view shown partially in cross-section of a portion of a compression and/or expansion device, according to another embodiment.

[0013] FIG. 4B is a cross-sectional view of the compression and/or expansion device of FIG. 4A, taken along line 4B-4B in FIG. 4A.

[0014] FIG. 5A is a side view shown partially in cross-section of a portion of a compression and/or expansion device, according to another embodiment and shown in a first configuration.

[0015] FIG. 5B is a side a side view shown partially in cross-section of the portion of a compression and/or expansion device of FIG. 5A, shown in a second configuration.

[0016] FIG. 6A is a side view shown partially in cross-section of a portion of a compression and/or expansion device, according to another embodiment and shown in a first configuration.

[0017] FIG. 6B is a side a side view shown partially in cross-section of the portion of a compression and/or expansion device of FIG. 6A, shown in a second configuration.

[0018] FIG. 7A is a side view shown partially in cross-section of a portion of a compression and/or expansion device, according to another embodiment and shown in a first configuration.

[0019] FIG. 7B is a side a side view shown partially in cross-section of the portion of a compression and/or expansion device of FIG. 7A, shown in a second configuration.

[0020] FIG. 8 is a side view shown partially in cross-section of a portion of a compression and/or expansion device, according to another embodiment.

[0021] FIG. 9 is a side view shown partially in cross-section of a portion of a compression and/or expansion device, according to another embodiment.

[0022] FIG. 10A is a side view shown partially in cross-section of a portion of a compression and/or expansion device, according to another embodiment and shown in a first configuration.

[0023] FIG. 10B is a side a side view shown partially in cross-section of the portion of a compression and/or expansion device of FIG. 10A, shown in a second configuration.

[0024] FIG. 11A is a side view shown partially in cross-section of a portion of a compression and/or expansion device, according to another embodiment and shown in a first configuration.

[0025] FIG. 11B is a side a side view shown partially in cross-section of the portion of a compression and/or expansion device of FIG. 11A, shown in a second configuration.

DETAILED DESCRIPTION

[0026] Systems, methods and devices used to compress and/or expand a gas, such as air, and/or to pressurize and/or pump a liquid, such as water, are described herein. Such devices and systems can be used, for example, within a compressed air energy storage (CAES) system. In some compression and/or expansion devices and systems, a hydraulic actuator can be used to move or compress a gas within a pressure vessel. For example, an actuator can move a liquid within a pressure vessel such that the liquid compresses the gas in the pressure vessel. Such compression devices and systems are described in U.S. patent application Ser. No. 12/785,086; U.S. patent application Ser. No. 12/785,093; and U.S. patent application Ser. No. 12/785,100, each titled “Compressor and/or Expander Device” (collectively referred to as “the Compressor and/or Expander Device applications”), incorporated herein by reference in their entirety. The Compressor and/or Expander Device applications describe a CAES system that can include multiple stages of compression and/or expansion. Other examples of devices and systems for expanding and/or compressing as gas are described in U.S. Provisional Patent App. No. 61/290,107, to Aborn et. al. (“the Aborn application”), entitled “System and Methods for Optimizing efficiency of a Hydraulically Actuated System,” the disclosure of which is incorporated herein by reference in its entirety.

[0027] In some compression and/or expansion devices and systems, a piston can be movably disposed within a cylinder or pressure vessel and actuated to compress air within the cylinder or pressure vessel. Such a device can include a single-acting piston configured to compress gas when moved in a single direction, or a double-acting piston configured to compress gas when moved in either direction. Examples of such compressed air devices and systems are described in U.S. Patent App. No. 61/420,505, to Ingersoll et. al. (“the Ingersoll application”), entitled “Compressor and/or Expander Device with Rolling Piston Seal,” the disclosure of which is incorporated herein by reference in its entirety.

[0028] In some embodiments, the devices and systems described herein can be configured for use only as a compressor. For example, in some embodiments, a compressor device described herein can be used as a compressor in a natural gas pipeline, a natural gas storage compressor, or any other industrial application that requires compression of a gas. In another example, a compressor device described herein can be used for compressing carbon dioxide. For example, carbon dioxide can be compressed in a process for use in enhanced oil recovery or for use in carbon sequestration.

[0029] In some embodiments, the devices and systems described herein can be configured for use only as an expansion device. For example, an expansion device as described herein can be used to generate electricity. In some embodiments, an expansion device as described herein can be used in a natural gas transmission and distribution system. For example, at the intersection of a high pressure (e.g., 500 psi) transmission system and a low pressure (e.g., 50 psi) distri-

bution system, energy can be released where the pressure is stepped down from the high pressure to a low pressure. An expansion device as described herein can use the pressure drop to generate electricity. In other embodiments, an expansion device as described herein can be used in other gas systems to harness the energy from high to low pressure regulation.

[0030] In some embodiments, a compression and/or expansion device as described herein can be used in an air separation unit. In one example application, in an air separator, a compression and/or expansion device can be used in a process to liquefy a gas. For example, air can be compressed until it liquefies and the various constituents of the air can be separated based on their differing boiling points. In another example application, a compression and/or expansion device can be used in an air separator co-located with in a steel mill where oxygen separated from the other components of air is added to a blast furnace to increase the burn temperature.

[0031] A compression and/or expansion system can have a variety of different configurations and can include one or more actuators that are used to compress/expand a gas (e.g. air) within a compression/expansion device. In some embodiments, an actuator can include one or more pump systems, such as for example, one or more hydraulic pumps and/or one or more pneumatic pumps that can be use to move one or more fluids within the system between various water pumps and pressure vessels. As used herein, “fluid” can mean a liquid, gas, vapor, suspension, aerosol, or any combination thereof. The Compressor and/or Expander Device applications incorporated by reference above describe various energy compression and expansion systems in which the systems and methods described herein can be employed.

[0032] As described herein, devices and systems used to compress and/or expand a gas, such as air, and/or to pressurize and/or pump a liquid, such as water, can release and/or absorb heat during, for example, a compression process. The devices and systems described herein can include one or more heat transfer mechanisms to remove heat during the compression process. In some embodiments, a heat transfer element can be used as described, for example, in the Compressor and/or Expander Device applications and/or the Ingersoll application incorporated herein. During an expansion process in a CAES system, when compressed air is released from a storage structure and expanded through the compressor/expander system, heat from a source can be added to the air to increase the power generated during the expansion process. In some embodiments, the source of heat can be at a relatively low temperature (e.g., between for example, about 10° C. and about 50° C.).

[0033] In some embodiments, a heat transfer element can be positioned within the interior of a pressure vessel of a compressor/expander device to increase the amount of surface area within the pressure vessel that is in direct or indirect contact with gas, which can improve heat transfer. The heat transfer element may be configured to minimize the distance that heat must travel through the air in order to reach the heat transfer element, such as a maximum distance of 1/8 of an inch, and other distances. The heat transfer element can provide for an increased heat transfer area both with gas that is being compressed and with gas that is being expanded (through a gas/liquid interface area and/or gas/heat transfer element interface), while allowing the exterior structure and overall shape and size of a pressure vessel to be optimized for other considerations, such as pressure limits and/or shipping

size limitations. In some embodiments, the heat transfer element can be a thermal capacitor that absorbs and holds heat released from a gas that is being compressed, and then releases the heat to a gas or a liquid at a later time. In some embodiments, the heat transfer element can be a heat transferring device that absorbs heat from a gas that is being compressed, and then facilitates the transfer of the heat outside of the pressure vessel.

[0034] In some embodiments, heat energy can be removed from a gas during compression via a liquid that is present in one or more pressure vessels of a compressor/expander device to maintain the gas that is being compressed at a relatively constant temperature. The heat energy can be transferred from the gas to the liquid and/or the compressor and/or expander device to a heat transfer element disposed within the pressure vessel. After gas is provided to the compressor/expander device, heat energy is removed from the gas, i.e. the gas is kept cooler as it is compressed than would be the case without the heat transfer element, and may be done to an extent that the temperature of the gas remains relatively constant. The temperature of the gas can be maintained, for example, at about 5° C., 10° C., 20° C., 30° C. or other temperatures that may be desirable, until discharged to, for example, a compressed gas storage structure or a subsequent compression stage. The gas stored in the storage structure may be heated (or cooled) naturally through conductive and/or convective heat transfer if the storage structure is naturally at a higher (or lower) temperature. For example, in some cases, the storage structure may be an underground structure, such as a salt cavern constructed in a salt dome that are used for storing the compressed gas. In some embodiments, the heat transfer element can be designed such that the temperature of the gas does not remain relatively constant, but instead increases a relatively small amount, for example, 5° C., 10° C., 20° C., 30° C.

[0035] As discussed above, heat may be added to the gas during an expansion process. For example, heat can be added to the gas at some or all of the stages of a multi-stage compression/expansion system to hold gas temperatures at a substantially constant temperature, such as at about 35° C., or other temperatures, during the entire expansion process. The overall temperature change of gas during expansion may be limited by contact with substantial heat transfer surfaces, e.g. a heat transfer element.

[0036] As discussed above, heat can be transferred from and/or to gas that is compressed and/or expanded by liquid (e.g., water) within a pressure vessel. A gas/liquid or gas/heat element interface may move and/or change shape during a compression and/or expansion process in a pressure vessel. This movement and/or shape change may provide a compressor/expander device with a heat transfer surface that can accommodate the changing shape of the internal areas of a pressure vessel in which compression and/or expansion occurs. In some embodiments, the liquid may allow the volume of gas remaining in a pressure vessel after compression to be nearly eliminated or completely eliminated (i.e., zero clearance volume).

[0037] A liquid (such as water) can have a relatively high thermal capacity as compared to a gas (such as air) such that a transfer of an amount of heat energy from the gas to the liquid avoids a significant increase in the temperature of the gas, but only incurs a modest increase in the temperature of the liquid. This allows buffering of the system from substantial temperature changes. Said another way, this relationship

creates a system that is resistant to substantial temperature changes. Heat that is transferred between the gas and liquid, or components of the vessel itself, may be moved from or to the pressure vessel through one or more processes. In some embodiments, heat can be moved in or out of the pressure vessel using mass transfer of the compression liquid itself. In other embodiments, heat can be moved in or out of the pressure vessel using heat exchange methods that transfer heat in or out of the compression liquid without removing the compression liquid from the pressure vessel. Such heat exchangers can be in thermal contact with the compression liquid, components of the pressure vessel, a heat transfer element, or any combination thereof. Furthermore, heat exchangers may also use mass transfer to move heat in or out of the pressure vessel. One type of heat exchanger that can be used to accomplish this heat transfer is a heat pipe as described in the Compressor and/or Expander Device applications and the Aborn application incorporated by reference above. Thus, the liquid within a pressure vessel can be used to transfer heat from gas that is compressed (or to gas that is expanded) and can also act in combination with a heat exchanger to transfer heat to an external environment (or from an external environment).

[0038] In some embodiments, heat can be transferred from a gas (such as air) that is compressed in a pressure vessel to increase the efficiency of the compression process. Heat can be transferred from the gas to a liquid, and/or from the gas to a heat transfer element within the compression vessel, and/or from the compression liquid while it is inside or outside of the pressure vessel. The amount of heat transferred from an amount of gas being compressed depends on the rate of heat transfer from the gas and on the time over which the heat transfer takes place, i.e. over the cycle time during which the gas compression takes place. Thus, for a given rate of heat transfer that can be achieved by a system, the more slowly the system is operated (i.e., the longer the compression cycle times), the more closely the compression cycle can approach isothermal compression. However, slower compression cycle times also correlate to lower gas volumetric and/or mass flow rates. In the context of a CAES system, this equates to lower energy storage rates, equivalently known as lower power. Conversely, in a gas expansion process, the more slowly the system is operated, the more heat energy can be transferred to the expanding gas (for a given heat transfer rate) and the more closely the more closely the expansion cycle can approach isothermal expansion, which may correspond to more efficient consumption of air mass relative to energy extracted/converted. However, in the context of a CAES system, the resulting lower expanding gas flow rate may equate to lower power production.

[0039] The use of a liquid (e.g. water) as a medium through which heat passes (directly through contact between the gas and liquid, or indirectly through an intermediary material) during compression and/or expansion may allow for continuous cooling or heating at enhanced heat transfer rates and may provide a mechanism by which heat may be moved in and/or out of the pressure vessel. That is, during compression the liquid may receive heat from gas that is being compressed, and transfer this heat from the pressure vessel to the external environment continuously, both while gas is being compressed and while gas is being received by the pressure vessel for later compression. Similarly, heat addition may occur when a compressor/expander device is operating in an expan-

sion mode both during expansion and as expanded gas is passed from the pressure vessel.

[0040] In some embodiments, a heat transfer element can be provided within a pressure vessel that can provide sufficient gas/liquid interface and sufficient thermal capacity to efficiently intermediate in the transfer of heat from the compressed gas into the liquid. A heat transfer element can be a variety of different configurations, shapes, sizes, structures, etc. to provide a relatively high surface area per unit volume or mass with the air as it is being compressed and/or at an end of the stroke of a compression cycle. The heat transfer element can be formed from one or more of a variety of different materials that provide a relatively high volumetric specific heat as compared to air. The combined effects of density, volume and specific heat, and how these parameters behave per unit volume, can contribute to the absorption performance of a particular heat transfer element. For example, both water and various metals provide a relatively high volumetric specific heat as compared to air, particularly at atmospheric air density. Thus, when the metal or water absorbs the heat from the air as it is being compressed, the air and/or water temperature increases only moderately.

[0041] For example, the mass specific heat values for air, water and stainless steel (one example metal that can be used) can be as follows:

[0042] air: 1,005 J/kg-K;

[0043] water: 4,183 J/kg-K; and

[0044] stainless steel: 502 J/kg-K.

[0045] The above values are only one example of the mass specific heat values for air, water and stainless steel, as specific heat of a particular material can depend on other factors such, as, for example, the temperature of the material. The heat absorbing capability per unit volume of the material is a factor of both a material's density and the mass specific heat of the material. The density of material can also depend on the temperature of the material. An example of possible material densities for air, water and stainless steel are as follows:

[0046] air: 1.2 kg/m³ (at sea level pressure and 20° C.);

[0047] water: 998 kg/m³; and

[0048] stainless steel: 8,027 kg/m³.

[0049] By combining the mass specific heat and density, the heat absorbing performance per unit volume (which may also be referred to as heat capacity) for air, water and stainless steel can be determined as follows:

[0050] air: 1,005 J/kg-K×1.2 kg/m³=1,206 J/m³-K (at sea level pressure and 20° C.);

[0051] water: 4,183×998 kg/m³=4,174,634 J/m³-K; and

[0052] stainless steel: 502 J/kg-K×8,027 kg/m³=4,029,554 J/m³-K.

[0053] In the above example, the air has a relatively small volumetric specific heat relative to both water and stainless steel. The high heat absorbing performance of an air-to-metal interface can provide a compressor/expansion device that uses metal as an intermediate absorption mechanism (between the air and the water) to a greater extent than the direct air-to-water absorption mechanism.

[0054] It should be understood that the calculation of heat absorbing performance (e.g., heat capacity) discussed above is merely one example, as the density and specific heat values of air, water and stainless steel, can vary depending on other factors, such as, for example, temperature, pressure and grade of material. For example, the density of air, and thus its heat capacity, scales approximately linearly with pressure (at a given temperature), so that the values above are higher by a

factor of 10 at a pressure of 10 bar, and a factor of 100 at a pressure of 100 bar. Similarly, the density and heat capacity of air scale approximately linearly, but inversely, with temperature (at a given pressure). Thus, the values of density and heat capacity of air at 586K (313° C.) are approximately half of the values at 293K (20° C.). However, even at the higher end of the range of air pressures that can be produced by a compressor/expander device as described herein, the heat capacity of air is one or two orders of magnitude lower than water or stainless steel. In addition, other materials can be used for the heat transfer element, such as, for example, tungsten and titanium. Tungsten can have, for example, a density of 19,300 kg/m³ and a specific heat of 132 J/kg-K to provide a heat absorbing performance per unit volume of 2,548,000 J/m³-K. Titanium can have for example, a density of 4,510 kg/m³ and a specific heat of 520 J/kg-K to provide a heat absorbing performance per unit volume (or heat capacity) of 2,345,200 J/m³-K. As with stainless steel, the density and specific gravity can vary depending on, for example, the temperature, pressure and particular grade of the material.

[0055] In an embodiment that uses a metal heat transfer element, the heat absorbed by the metal can be transferred to the liquid (e.g., water) in the system, which as described previously can be transferred out of the pressure vessel by other methods such as a heat exchanger (e.g., heat pipes or other mechanisms).

[0056] FIG. 1 schematically illustrates a portion of a compression and/or expansion device (also referred to herein as “compression/expansion device”) according to an embodiment. A compression/expansion device 100 can include one or more pressure vessels 120 (also referred to herein as “cylinder”) having a working chamber 140, an actuator 122 by which the volume of working chamber 140, and/or the portion of the volume of the working chamber 140 that can be occupied by gas, can be changed (decreased to compress the gas, increased to expand the gas), and one or more heat transfer elements 124 disposed within the working chamber 140. The compression/expansion device 100 can be used, for example, to compress or expand a gas, such as air, within the working chamber 140. The compression/expansion device 100 can be used, for example, in a CAES system.

[0057] The pressure vessel 120 can include one or more gas inlet/outlet conduits 130 in fluid communication with the working chamber 140. Optionally, the pressure vessel 120 can include one or more liquid inlet/outlet conduits 128 in fluid communication with the working chamber 140. The working chamber 140 can contain at various time periods during a compression and/or expansion cycle, a quantity of gas (e.g., air) that can be communicated to and from working chamber 140 via the inlet/outlet conduits 130, and optionally can also contain a quantity of liquid (e.g., water) that can be communicated to and from working chamber 140 via the inlet/outlet conduits 128. The compression/expansion device 100 can also include multiple valves (not shown in FIG. 1) coupled to the inlet/outlet conduits 128, 130 and/or to the pressure vessel 120. The valves can be configured to operatively open and close the fluid communication to and from the working chamber 140. Examples of use of such valves are described in more detail in the Compressor and/or Expander Device applications incorporated by reference above.

[0058] The actuator 122 can be any suitable mechanism for selectively changing the volume of the working chamber 140 and/or the portion of the volume of the working chamber that can be occupied by gas. For example, the working chamber

140 can be defined by a cylinder and the face of a piston **160** disposed for reciprocal movement within the cylinder. Movement of the piston **160** in one direction would reduce the volume of the working chamber **140**, thus compressing gas contained in the working chamber **140**, while movement of the piston **160** in the other direction would increase the volume of the working chamber **140**, thus expanding gas contained in the working chamber **140**. The actuator **122** can thus be the piston **160** and a suitable device for moving the piston **160** within the cylinder, such as a pneumatic or hydraulic actuator such as, for example, the hydraulic actuators described in the Aborn application incorporated by reference above.

[0059] In some embodiments, the working chamber can have a fixed volume, i.e. a volume defined by a chamber with fixed boundaries, and the portion of the volume of the working chamber **140** that can be occupied by gas can be changed by introducing a liquid into, or removing a liquid from, the working chamber **140**. Thus, the working chamber **140** has a volume with a first portion containing a volume of liquid, and a second portion that can contain gas, which volume is the total volume of the working chamber **140** less the volume of the first portion (the volume of the liquid). In such embodiments, the actuator **122** can be any suitable device for introducing liquid into, or removing liquid from, the working chamber, such as a hydraulic actuator that can move a liquid in and out of the working chamber **140** via liquid inlet/outlet conduit **128**. In such an embodiment, the actuator **122** can include a water pump (not shown) that drives a hydraulically driven piston (not shown) disposed within a housing (not shown) and can be driven with one or more hydraulic pumps (not shown) to move a volume of liquid in and out of the working chamber **140**. An example of such a hydraulic actuator is described in the Compressor and/or Expander Device applications incorporated by reference above.

[0060] In some embodiments, the working chamber can be configured to combine the techniques described above, i.e. the working chamber can have a variable volume, e.g. using a cylinder and piston as described above, and the portion of the variable volume that can be occupied by gas can be changed by introducing liquid into, or removing a liquid from, the working chamber. In another embodiment, a constant volume of liquid can be maintained in the variable volume working chamber throughout all, or a portion, of the compression cycle.

[0061] The heat transfer element **124** can be a variety of different configurations, shapes, sizes, structures, etc. to provide a relatively high surface area per unit volume or mass that can be in contact with the gas (e.g., air) as it is being compressed or expanded within the working chamber **140**. In some embodiments, it may be desirable to include a heat transfer element **124** that can be formed with a material that can provide high thermal conductivity in a transverse and a longitudinal direction within the working chamber **140**. The heat transfer element **124** can be formed from one or more of a variety of different materials. For example, the heat transfer element **124** can be formed with metals (e.g. stainless steel), metal wires, hybrid wires, carbon fiber, nano-materials, and composite materials (e.g. carbon polymer compounds) which have anti-corrosion properties, are lighter weight, and are less expensive than some metallic materials.

[0062] The heat transfer element **124** can be disposed at various locations within the working chamber **140** so as to optimize the heat transfer within the pressure vessel **120**. For

example, in some embodiments, the heat transfer element **124** can be disposed within the working chamber **140** near an end portion of the working chamber **140** in a portion occupied by the gas (e.g., air) near the end of a compression cycle. As the gas is compressed during the compression cycle, the work done on the gas adds heat energy to the gas. The heat energy is continuously transferred (primarily by conductive and/or convective, rather than radiant, heat transfer) to the heat transfer element **124**. This transfer maintains the gas temperature at a lower value than would be the case without the heat transfer element **124**, and moderately increases the temperature of the heat transfer element **124**.

[0063] As described above, in some embodiments, the working chamber **140** can contain a liquid, and/or the actuator **122** can be used to change the portion of the working chamber **140** that is available to contain gas, by moving a liquid, such as water, into and out of the working chamber, such that gas, such as air, within the working chamber **140** is compressed by the liquid. In such embodiments, depending on the rate at which the working chamber **140** is filled with liquid, and the heat transfer properties of the heat transfer element **124**, the gas and the heat transfer element **124** will be relatively closer or farther from thermal equilibrium, and thus, during some or all of the compression cycle, the liquid in the working chamber **140** can be caused to contact the heat transfer element **124** to receive from the heat transfer element **124** heat energy it received from the compressed gas. Optionally, at the end of the compression cycle, any pressurized gas remaining in the working chamber **140** can be released from the working chamber **140**, and transferred to the next step or stage in the compression process or to a storage facility. Liquid can then be moved into the working chamber **140**, to substantially fill the volume occupied by gas that was released from the working chamber **140** after compression (which volume is now filled with gas at a lower pressure) by introducing more liquid and/or by reducing the volume of the working chamber (e.g. by moving a piston). The heat energy stored in the heat transfer element **124** can then be transferred (again, by conductive and/or convective transfer) to the water in the working chamber **140**.

[0064] In some embodiments, the heat transfer element **124** can be disposed within a substantial portion of the working chamber **140** such that air and water can flow through, along, and/or across the heat transfer element **124** as the liquid fills an increasingly larger portion of the volume of the working chamber **140** and compresses the air within the working chamber **140**. In such an embodiment, the heat transfer element **124** can be in contact with both air and water from the beginning of the compression cycle, with progressively less being exposed to air, and more being exposed to water, as the cycle progresses.

[0065] In some embodiments, the heat transfer element **124** can have a density that varies spatially within the heat transfer element, so that the heat transfer can be tailored. For example, in some embodiments, the heat transfer element **124** can be disposed within a substantial portion of the pressure vessel **120** as described above, and have a density that varies from the bottom to the top of the heat transfer element **124**. For example, the density of the heat transfer element **124** can increase as the air moves from the beginning of the compression cycle to the end of the compression cycle. In other words, the heat transfer element **124** is more dense where the air is disposed near the end of the compression cycle than where the air is disposed at the beginning of the compression cycle. The

density can be varied by varying the composition of the heat transfer element (i.e. using materials of different density) and/or by varying the amount of heat transfer material per unit volume (e.g. by more closely packing discrete components of the heat transfer element, such as rods, tubes, filaments, etc.).

[0066] In some embodiments, the heat transfer element 124 can be designed to maximize the amount of gas in the working chamber 140 to be compressed. Thus, increasing the mass of gas that can be compressed for any given size of pressure vessel 120 increases the power density of that device. As the density (e.g., the amount of heat transfer material per unit volume) of the heat transfer element 124 increases, the remaining volume in the working chamber 140 available for a mass of gas to be compressed decreases. Although the increased density of heat transfer element 124 improves the transfer of heat energy from the gas being compressed to the heat transfer element 124, the volume of gas being compressed with each compression cycle is reduced. Said another way, volume of the working chamber 140 occupied by the heat transfer element 124 directly reduces the mass of gas that can be compressed with any given pressure vessel 120. Furthermore, reducing the size of the heat transfer element 124 can reduce the capital equipment costs (e.g. by savings on materials) and operating costs (e.g. decreasing the overall weight of the equipment being moved by the actuator). Thus, in some embodiments, the heat transfer element 124 can be designed such that the heat transfer element has sufficient surface area to remove the heat energy generated by the compression of the gas, while minimizing the volume of the working chamber 140 occupied by the heat transfer element 124 to maximize the volume in the working chamber 140 for gas to be compressed. In some embodiments, multiple transfer elements 124 can be movable with respect to each other such that the density of the heat transfer element 124 in a given portion of the working chamber 140 can be varied throughout a compression/expansion cycle to maximize heat transfer surface area and minimize heat transfer element volume 124.

[0067] In some embodiments, the working chamber 140 can be partially filled with a liquid (e.g. water) that can be communicated to and from the working chamber 140 via the inlet conduit 128 and the outlet conduit 130, respectively, or via other conduits (not shown). During the compression cycle, heat energy generated during the compression process can be transferred from the gas, to the heat transfer element 124, and then to the liquid. A volume of the heated liquid can then be discharged from the pressure vessel 120 via the outlet conduit 130 or via a separate liquid discharge conduit (not shown). As described above with respect to the heat transfer element 124, the volume of liquid that occupies a portion of working chamber 140 reduces the remaining volume of the working chamber 140 available for a mass of gas to be compressed. In other words, although the liquid in the working chamber 140 provides a mechanism by which the heat energy generated by the compression of the gas can be removed from the pressure vessel 120 (i.e. by first quenching the heat transfer element 124 to transfer the heat energy to the liquid, and then discharging the heated liquid out of the pressure vessel 120), both the liquid and the heat transfer element occupy a portion of the working chamber 140, thereby reducing the mass of gas that can be compressed. In some embodiments, the heat transfer element and the volume of liquid in the working chamber 140 can be designed to remove a sufficient amount of heat energy generated during the compression

process, while maximizing the amount of gas in the working chamber 140 to be compressed. For example, having multiple heat transfer elements 124 that are movable with respect to each other such that the density of the heat transfer element 124 disposed in the portion of the working chamber containing gas can be varied throughout a compression cycle can reduce the volume of liquid for quenching the heat transfer element 124.

[0068] In some embodiments, more than one heat transfer element 124 can be used. For example, in such an embodiment, more than one of the same type of heat transfer element 124 can be used, or a combination of different types or configurations of heat transfer elements 124 can be used. In addition, within a given compression/expansion device 100, one or more of the same or different combinations of heat transfer elements 124 can be used in one or more of the working chambers 140 of that system. In some embodiments, one or more heat transfer elements 124 can be positioned within the working chamber 140 such that the density of the heat transfer elements is varied within the pressure vessel 120.

[0069] In some embodiments, the heat transfer element 124 can include multiple tubular members arranged concentrically within each other. The concentric tubular members can be placed within the interior of the working chamber 140 in a vertical orientation (i.e. an orientation approximately perpendicular to the surface of liquid contained in the working chamber 140) such that air can flow through the annular spaces created by the concentric tubular members as it is moved through the working chamber 140 during a compression cycle. In some embodiments, the concentric tubular members may have a varying diameter along their length. For example, the concentric tubular members can have a tapered shape, an hourglass shape, or some other suitable shape.

[0070] In some embodiments, the heat transfer element 124 can include multiple elongate members (which may be solid and/or tubular) arranged in a bundle and oriented in a vertical orientation within the working chamber 140. As air flows through the pressure vessel 120 during a compression cycle, the air can flow in between or through the elongate members (e.g., if tubular elongate members). In some embodiments, the tubular elongate members and/or solid elongate members may have a varying diameter along their length. For example, the tubular members or elongate members can have a tapered shape, an hourglass shape, or some other suitable shape. In some embodiments, the bundle of elongate members can be optimized for spacing between the elongate members, and which can vary, for example, along a length or height of the elongate members.

[0071] In some embodiments, the heat transfer element 124 can include tessellating metal plates or a stack of metal plates. The plates can be, for example, planar or curved, porous plates, or mesh screens. In some embodiments, the plates can slide with respect to each other, thereby modifying the heat transfer surface area per unit volume of air as the stroke progresses. Such an embodiment of a heat transfer element 124 based on tessellating plates may be valuable for implementing a smaller or more compact pressure vessel 120. For example, during a compression stroke that reduces the gas volume in which the heat transfer element 124 is disposed, the heat transfer element 124 may be tessellation pack into a volumetrically compact form. This packing may be designed to occur in concert with the compression stroke. During an expansion stroke, the heat transfer element 124 may unpack

and thereby volumetrically expand in concert with the expansion stroke. The plates may be moved or displaced by the engagement with a moving boundary of the working chamber 140, e.g. a piston face, and/or by liquid contained within the working chamber 140 (e.g. if the plates are buoyant), and/or by an actuator.

[0072] In some embodiments the heat transfer element 124 can include one or more metal coils. For example, the heat transfer element 124 can include structures in the form of stacking coils, conical spiraling coils, or flexible helical coils similar to a Slinky®. Such an embodiment can have an effect that is similar to the tessellating plate embodiment described above in that relative motion between various locations on the coil allows the heat transfer element 124 to grow or shrink in axial dimension through the cycle (e.g., compression or expansion cycle), providing the same heat transfer surface area as a rigid design within a smaller enclosed volume while accommodating a change in the corresponding dimension of the working chamber 140 (e.g. with movement of a piston bounding one end of the working chamber 140).

[0073] In some embodiments, the heat transfer element 124 can include one or more fabric elements and/or one or more fiber elements and/or structures that can absorb liquid similar to a mop or sponge. Such a heat transfer element 124 can be used, for example, in embodiments in which liquid is contained in the working chamber (e.g. in which the portion of the volume of the working chamber 140 available to be occupied by gas can be changed by introducing liquid into, or removing liquid from, the working chamber 140). The heat transfer element can wick liquid along its length into contact with air in the working chamber, and/or once wetted by direct contact with the liquid can retain the liquid on its surface, e.g. in the form of a film or droplets. In such an embodiment of a heat transfer element 124, the liquid on the heat transfer element provides a gas-to-liquid interface that can facilitate heat transfer can to the fabric and/or fiber elements.

[0074] In some embodiments, the heat transfer element 124 can implement a three dimensional net structure of fiber-form material. Such fibers may hold liquid, or liquid droplets, in a spatially distributed pattern that may create an air-to-liquid geometry that beneficially facilitates the ready flow of heat energy between the air and the liquid. The fibers may also include surface treatments and/or surface coatings (e.g. of hydrophilic materials) that enhance the liquid adhesion behavior of the fiber structure. In some such embodiments, a three dimensional fiber network can bring air into intimate contact with the process liquid at all, or substantially all, locations within the working chamber 140, rather than just at the interface of the liquid and the air (i.e. the liquid's surface). In this manner, heat transfer can occur directly from the air into the process liquid (e.g. water).

[0075] In some embodiments, the heat transfer element 124 can be stationary in that it remains substantially in a fixed position within the working chamber 140 during a compression cycle. In some embodiments, the heat transfer element 124 can be movable or dynamic in that it can move within the working chamber 140 during a compression and/or expansion cycle. In some embodiments, the heat transfer element 124 can collapse and expand within the working chamber 140. For example a stack of metal coils or stack of tessellating plates described above can be configured to collapse and expand within the working chamber 140. In some embodiments that include a compression and expansion device using a piston to change the volume of the working chamber 140, a

heat transfer element 124 can move with the stroke of the piston, e.g. by engagement with the face of the piston. In some embodiments, the heat transfer element 124 can move (e.g., collapse and expand) in a longitudinal direction and/or vertical direction. In some embodiments, the heat transfer element 124 can move (e.g., collapse and expand) in a radial direction.

[0076] Heat energy transferred from the gas to the heat transfer element 124 can in turn be transferred out of the pressure vessel 120 by any suitable means, include a heat pipe, circulating fluid, etc., to a location where it can be dissipated, used in other processes, and/or stored for future use in the compression/expansion device (e.g. in an expansion cycle). In addition, or alternatively, heat energy transferred from the gas to the heat transfer element 124 can be transferred from the heat transfer element 124 to fluid contained in the working chamber 140. The heat energy can then be transferred from the fluid out of the pressure vessel. Similar techniques can be used to transfer heat energy from outside the pressure vessel to the heat transfer element 124 and thence to the gas in the working chamber, e.g. during an expansion cycle.

[0077] FIGS. 2A and 2B illustrate a compression/expansion device according to another embodiment. A compression/expansion device 200 includes a pressure vessel 220, a working chamber 240 contained within the pressure vessel, an actuator 222 coupled to the pressure vessel 220, and a heat transfer element 224 disposed within working chamber 240. The compression/expansion device 200 can be used, for example, to compress a gas, such as air, within the pressure vessel 220 and/or to pressurize and/or pump a liquid, such as water. The compression/expansion device 200 can also be used in a compression and expansion system such as a compressed air energy storage system.

[0078] The compression/expansion device 200 also includes an inlet conduit 228 (also referred to as "inlet") and an outlet conduit 230 (also referred to as "outlet") each in fluid communication with the working chamber 240 and configured to communicate a liquid to and from the working chamber 240, from and to the actuator 222, respectively. The compression/expansion device 200 also includes an inlet conduit 232 and an outlet conduit 234 each in fluid communication with the working chamber 240. The inlet 232 is configured to introduce gas (e.g., air) into the working chamber 240, and the outlet 234 is configured to remove gas out of the pressure vessel 220. The compression/expansion device 200 can also include multiple valves 236 coupled to the inlets 228, 232 and outlets 230, 234 and/or to the pressure vessel 220, as described previously. The valves can be configured to operatively open and close the fluid communication to and from the working chamber 240.

[0079] As described above for actuator 122, the actuator 222 can be, for example a pneumatic or hydraulic actuator that moves a liquid in and out of the working chamber 240 via the inlet 228 and the outlet 230, respectively. For example, the actuator 222 can include a water pump (not shown) that drives a hydraulically driven piston (not shown) disposed within a housing (not shown) and can be driven with one or more hydraulic pumps (not shown) to move the liquid in and out of the working chamber 240. For example, a volume of liquid can be moved into the working chamber 240 via the inlet 228 such that the volume of the working chamber 240 that can contain the quantity of gas within the working chamber 240 is reduced, thus compressing the gas, which can be discharged from the working chamber 240 via the outlet 234. After the

compressed gas has exited the pressure vessel 220, the liquid can be moved out of the working chamber 240 via the outlet 230 as a quantity of gas is introduced into the working chamber 240 via the inlet 232. This process can be repeated to alternately pump liquid and gas into and out of the pressure vessel.

[0080] As described above, heat energy is generated during the compression cycle by the compression of the gas contained within the working chamber 240. Some of this heat energy can be transferred from the gas to the liquid introduced into the working chamber 240 during the compression process. Some of this heat energy can also be transferred from the gas to the heat transfer element 224.

[0081] In this embodiment, the heat transfer element 224 includes multiple elongate members 238 arranged in a bundle and extending vertically within the working chamber 240. The elongate members 238 can be coupled together with a strap or band 250 that is coupled to the wall of the pressure vessel 220 with a suitable coupling mechanism 252, such as, for example, a bracket or clamp bolted to the wall of the pressure vessel 220. As the liquid flows into the working chamber 240 via the inlet 228, the liquid can flow between the elongate members 232 and compress the gas (e.g., air) disposed within the working chamber 240, until the compressed air exits the outlet 234. Thus, heat energy generated during the compression cycle can be transferred from the gas to the liquid and/or to the elongate members 238 of the heat transfer element 224.

[0082] In alternative embodiments, the bundle of elongate members 238 can be coupled to the pressure vessel using different coupling methods and/or coupled at a different location than illustrated in FIGS. 2A and 2B. In some embodiments, the elongate members 238 can have a length such that they extend to a bottom surface of the working chamber 240 and/or a top surface of the working chamber 240. Additionally, although the elongate members 238 are shown solid in the above example, it should be understood the heat transfer element 224 can alternatively include elongate members that are tubular (e.g., have internal lumens). In such an alternative embodiment, the air and liquid can flow between the elongate members and through the lumens of the elongate members.

[0083] FIGS. 3A and 3B illustrate a compression/expansion device according to another embodiment. A compression/expansion device 300 includes a pressure vessel 320, an actuator 322 coupled to the pressure vessel 320, and a heat transfer element 324 disposed within a working chamber 340 of the pressure vessel 320.

[0084] The compression/expansion device 300 also includes an inlet conduit 328 and an outlet conduit 330 each in fluid communication with the working chamber 340 and configured to communicate a liquid to and from the working chamber 340, from and to the actuator 322, respectively. The compression/expansion device 300 also includes an inlet conduit 332 and an outlet conduit 334 each in fluid communication with the working chamber 340. The inlet 332 is configured to introduce gas (e.g., air) into the pressure vessel 320, and the outlet 334 is configured to remove gas out of the pressure vessel 320. The compression/expansion device 300 can also include multiple valves 336 coupled to the inlets 328, 332 and outlets 330, 334 and/or to the pressure vessel 320, as described previously.

[0085] The actuator 322 can be structurally and functionally the same as, or similar to, the actuator 222 and can be

actuated to move a liquid in and out of the working chamber 340 via the inlet 328 and the outlet 330, respectively.

[0086] The heat transfer element 324 can be used to remove heat energy from the air within the working chamber 340 during the compression cycle as previously described. In this embodiment, the heat transfer element 324 includes a three-dimensional net or mesh structure. As described above, such a heat transfer element 324 can hold liquid, or liquid droplets, in a spatially distributed pattern to create an air-to-liquid geometry that can facilitate the ready flow of heat energy between the air and the liquid. In addition, although not necessary, in this embodiment, the heat transfer element 324 varies in density in a direction of movement of the surface of the liquid as liquid is added to the working chamber 340. For example, in this embodiment, the heat transfer element 324 includes four portions, 342, 344, 346 and 348 each having a different density, i.e. a different volume of fibers or filaments per unit volume in the working chamber 340. The portion 342 near the beginning of the compression cycle has the lowest density, and the portion 348 near the end of the compression cycle has the highest density. The increase in density from portion 342 to portion 348 helps to compensate for the decreasing axial length of the heat transfer element that is exposed to the gas as the surface of the liquid rises—the higher surface area per unit length allows for more heat transfer from the air to the heat transfer element 324 than in the lower density portions of the heat transfer element 324.

[0087] FIGS. 4A and 4B illustrate another embodiment of a compression/expansion device. A compression/expansion device 400 includes a pressure vessel 420 and an actuator 422 coupled to the pressure vessel 420. The pressure vessel 420 and actuator 422 can each be structurally and functionally the same as, or similar to, the pressure vessels 220 and 320 and the actuator 222 and 322, and therefore, are not described in detail with reference to this embodiment. The compression/expansion device 400 also includes a heat transfer element 424 disposed within a working chamber 440 of the pressure vessel 420. As with the previous embodiments, the compression/expansion device 400 can be used to compress a gas, such as air, within the pressure vessel 420 and/or to pressurize and/or pump a liquid, such as water. The compression/expansion device 400 can also be used in a compression and expansion system such as a compressed air energy storage system.

[0088] In this embodiment, the heat transfer element 424 includes multiple tubular members 438 arranged concentrically within each other. The concentric tubular members 438 can be coupled to a wall of the pressure vessel 420 with, for example, one or more braces 450. The concentric tubular members 438 are disposed within the interior of the working chamber 440 in a vertical orientation such that gas and/or liquid can flow through the annular spaces created by the concentric tubular members 438 as the gas and/or liquid is moved through the pressure vessel 420 during a compression cycle. In some embodiments, the concentric tubular members 438 may have a varying diameter along their length. For example, in an alternative embodiment, a compression/expansion device 400 can include concentric tubular members 438 that are tapered. In some embodiments, the tubular members 438 can have varying lengths, e.g. some of the tubular members 438 extend the full length of the working chamber 440, while others extend only partway down from the top of the working chamber 440. This yields a total surface area per unit length of the portion of the heat transfer element 424 that is above the surface of the liquid (i.e. in contact with the gas)

that increases as the surface of the liquid rises—that is, the density of the heat transfer element 424 is higher at its upper end than at its lower end.

[0089] FIGS. 5A and 5B illustrate another embodiment of a compression/expansion device. A compression/expansion device 500 includes a pressure vessel 520 and an actuator 522 coupled to the pressure vessel 520. The compression/expansion device 500 also includes a heat transfer element 524 disposed within a working chamber 540 of the pressure vessel 520.

[0090] The compression/expansion device 500 also includes an inlet conduit 528 (also referred to as “inlet”) and an outlet conduit 530 each in fluid communication with the working chamber 540 of the pressure vessel 520 and configured to communicate a liquid to and from the working chamber 540, from and to the actuator 522, respectively. The compression/expansion device 500 also includes an inlet conduit 532 and an outlet conduit 534 each in fluid communication with the working chamber 540 of the pressure vessel 520. The inlet 532 is configured to introduce gas (e.g., air) into the working chamber 540, and the outlet 534 is configured to remove gas from the working chamber 540. The compression/expansion device 500 can also include multiple valves 536 coupled to the inlets 528, 532 and outlets 530, 534 and/or to the pressure vessel 520, as described previously.

[0091] The actuator 522 can be structurally and functionally the same as, or similar to, for example, the actuator 222 and can be actuated to move a liquid in and out of the working chamber 540 via the inlet 528 and the outlet 530, respectively.

[0092] As with previous embodiments, the heat transfer element 524 can be used to remove heat energy from the air within the working chamber 540 by providing an increased amount of surface area within the working chamber 540 that is in direct contact with the air being compressed. In this embodiment, the heat transfer element 524 includes multiple metal plates 538 (also referred to as “plates”) that are coupled together in a stack. In some embodiments, plates 538 having a positive buoyancy can be coupled together such that as the liquid flows within the pressure vessel 520 to compress the gas, the liquid can exert a force on the plates 538 causing the plates 538 to compact into a smaller overall height as shown in FIG. 5B. In other embodiments, plates 538 without positive buoyancy can be incorporated into devices 500 having a piston in the working chamber 540 such that the piston collapses the plates 538 as the stroke progresses. For example, the plates 538 can be coupled together with one or more cords 525 similar to window blinds. The cords 525 can also be used to couple the plates 538 to an interior wall of the pressure vessel 520. Although the heat transfer element 524 is shown as having a particular length or height within the working chamber 540 of the pressure vessel 520, it should be understood that the heat transfer element 524 can be any length within the pressure vessel 520. In some embodiments, for example, the heat transfer element 524 can have a length or height that extends substantially along the length or height of the working chamber 540 of the pressure vessel 540.

[0093] In use, to compress a gas, such as air within the compressor device 500, a volume of gas having a first pressure can be introduced through the inlet 528 and into the working chamber 540 of the pressure vessel 520. The actuator 522 can be actuated to pump a volume of liquid into the pressure vessel 520 via the inlet 528. As the liquid flows within the working chamber 540 of the pressure vessel 520 in the direction of arrow A (shown in FIG. 5B), the liquid can

compress the gas within the pressure vessel 520 and force or displace the compressed gas out of the pressure vessel 520 and into the outlet 530. Thus, the compressed gas exiting the working chamber 540 has a greater pressure than the gas that enters the working chamber 540. As the surface of the liquid in the direction of arrow A, the plates 538 of the heat transfer element 524 will collapse upon each other to form a dense stack at the end of the compression cycle as shown in FIG. 5B. During the compression cycle, heat energy generated during the process can be transferred from the gas to the heat transfer element 524 as described above for previous embodiments. As the heat transfer element 524 collapses upon itself during the compression cycle, the heat transfer element 524 becomes more dense, and therefore, more heat can be transferred to the heat transfer element 524 as the compression cycle progresses. Said another way, the total surface area of the heat transfer element 524 is available for heat transfer (i.e. is above the surface of the liquid and thus in contact with the air) at the end of the compression cycle as well as at the beginning of the cycle.

[0094] FIGS. 6A and 6B illustrate another embodiment of a compression/expansion device. A compression/expansion device 600 includes a pressure vessel 620 having a working chamber 640, a heat transfer element 624 disposed within the working chamber 640, and a piston 654 movable within the pressure vessel 620 to change the volume of the working chamber 640. The piston 654 can be coupled to a suitable actuator (not shown) via a piston rod 656. The actuator can be, for example, a hydraulic or pneumatic actuator and can include an electric motor as previously described.

[0095] The compression/expansion device 600 also includes an inlet conduit 628 and an outlet conduit 630 each in fluid communication with the working chamber 640. The inlet 628 can be coupled to a source of gas (e.g., air) and can communicate the gas to the working chamber 640. The outlet 630 can be configured to communicate the gas from the working chamber 640 to another location. Valves 636 can be coupled to the inlet 628 and outlet 630 and can be operated to open and close the fluid communication to and from the pressure vessel 620 as described above for previous embodiments.

[0096] As with previous embodiments, the heat transfer element 624 can be used to remove heat energy from the gas within the pressure vessel 620 by providing an increased amount of surface area within the pressure vessel 620 that is in direct contact with the gas being compressed. In this embodiment, the heat transfer element 624 includes a collapsible coil member (shown schematically). As the piston 654 moves during a compression cycle, the piston 654 can exert a force on the heat transfer element 624 causing the heat transfer element 624 to collapse or compact into a smaller overall height, as shown in FIG. 6B.

[0097] In some embodiments, the heat transfer element 624 can be coupled to the piston 654 such that it moves directly with the piston 654. In some embodiments, the heat transfer element 624 can be coupled to the pressure vessel 620. In some embodiments, the heat transfer element 624 can be coupled to both the piston 654 and the pressure vessel 620.

[0098] In use, to compress a gas, such as air, within the compression/expansion device 600, a quantity of gas having a first pressure can be introduced through the inlet 628 and into the working chamber 640. The piston 654 can be actuated to move the piston 654 from a first position as shown in FIG. 6A to a second position as shown in FIG. 6B. As the piston

654 moves in the direction of arrow A (shown in FIG. 6B), the piston **654** compresses the gas within the working chamber **640**. The compressed gas can then be expelled from the working chamber **640** via the outlet **630**. As the piston **654** moves in the direction of arrow A, the heat transfer element **624** (collapsible coil member) collapses, increasing its effective density. Its density is the greatest at the end of the compression stroke of the piston **554**. Said another way, the total surface area of the heat transfer element **624** is exposed to the air throughout the compression cycle.

[0099] In some embodiments, the working chamber **640** can be partially filled with a liquid (e.g., water) that can be communicated to and from the working chamber **640** via the inlet conduit **628** and the outlet conduit **630**, respectively, or via other conduits (not shown). During the compression cycle, heat energy generated during the compression process can be transferred from the gas, to the heat transfer element **624**, and then to the liquid as described above for previous embodiments. A volume of the heated liquid can then be discharged from the pressure vessel **620** via the outlet conduit **630** or via a separate liquid discharge conduit (not shown).

[0100] In some embodiments, the working chamber can be configured to combine the techniques described above, i.e. the working chamber can have a variable volume, e.g. using a cylinder and piston as described above, and the portion of the variable volume that can be occupied by gas can be changed by introducing liquid into, or removing a liquid from, the working chamber. For example, a quantity of gas having a first pressure can be introduced through the inlet **628** and into the working chamber **640**. The piston **654** can be actuated to move the piston **654** from a first position as shown in FIG. 6A to a second position as shown in FIG. 6B. As the piston **654** moves in the direction of arrow A (shown in FIG. 6B), the piston **654** compresses the gas within the working chamber **640**. During the compression cycle, heat energy generated during the compression process can be transferred from the gas, to the heat transfer element **624**. Before the start of the compression cycle, and/or at any time during the compression cycle, liquid can be introduced into the working chamber **640** via the inlet conduit **628** or via a separate liquid inlet conduit (not shown) to quench the heat transfer element **624**, thereby transferring the heat energy to the liquid as described above for previous embodiments. A volume of the heated liquid can then be discharged from the pressure vessel **620** via the outlet conduit **630** or via a separate liquid discharge conduit (not shown).

[0101] FIGS. 7A and 7B illustrate another embodiment of a compression/expansion device. A compression/expansion device **700** includes a pressure vessel **720** having a working chamber **740**, a heat transfer element **724** disposed within the working chamber **740**, and a piston **754** movable within the pressure vessel **720** to change the volume of the working chamber **740**. The piston **754** can be coupled to a suitable actuator (not shown) via a piston rod **756**. The actuator can be, for example, a hydraulic or pneumatic actuator and can include an electric motor as previously described.

[0102] The compression/expansion device **700** also includes an inlet conduit **728** and an outlet conduit **730** each in fluid communication with the working chamber **740**. The inlet **728** can be coupled to a source of gas (e.g., air) and can communicate the gas to the working chamber **740**. The outlet **730** can be configured to communicate the gas from the working chamber **740** to another location. Valves **736** can be coupled to the inlet **728** and outlet **730** and can be operated to

open and close the fluid communication to and from the pressure vessel **720** as described above for previous embodiments.

[0103] As with previous embodiments, the heat transfer element **724** can be used to remove heat energy from the gas within the pressure vessel **720** by providing an increased amount of surface area within the pressure vessel **720** that is in direct contact with the gas being compressed. In this embodiment, the heat transfer element **724** includes two rows of vertical fins with the second row being offset from the first row. As the piston **754** moves in the direction of arrow A during a compression cycle, the piston **754** moves the second row of vertical fins toward the first row of vertical fins that are attached to the pressure vessel **720**. The fins are offset such that the fins are interleaved at the end of the compression stroke as shown in FIG. 7B, thereby increasing the effective density of the heat transfer element **724**. Its density is the greatest at the end of the compression stroke of the piston **754**.

[0104] In some embodiments, the working chamber **740** can be partially filled with a liquid (e.g., water) that can be communicated to and from the working chamber **740** via the inlet conduit **728** and the outlet conduit **730**, respectively, or via other conduits (not shown). During the compression cycle, heat energy generated during the compression process can be transferred from the gas, to the heat transfer element **724**, and then to the liquid as described above for previous embodiments. A volume of the heated liquid can then be discharged from the pressure vessel **720** via the outlet conduit **730** or via a separate liquid discharge conduit (not shown).

[0105] FIG. 8 illustrates another embodiment of a compression/expansion device. A compression/expansion device **800** includes a pressure vessel **820** having a working chamber **840**, a heat transfer element **824** disposed within the working chamber **840**, an actuator **822**, and inlet and outlet conduits **828**, **830** in fluidic communication with the working chamber. The compression/expansion device may also include a piston (not shown) driven by actuator **822**. Gas contained in the working chamber can be compressed by introducing liquid into the working chamber to reduce the portion of the volume of the working chamber available to contain the gas and/or by reducing the volume of the working chamber by driving the piston towards the upper end of the working chamber. Alternatively, compressed gas in the working chamber can expel liquid from the working chamber, increasing the portion of the volume of the working chamber available to contain the gas, and/or urge the piston downwardly, allowing the gas to expand. The pressure vessel **820**, actuator **822**, inlet conduit **828** and outlet conduit **830**, etc. can each be structurally and functionally the same as, or similar to, the pressure vessels, actuators and conduits in other embodiments, and therefore, are not described in further detail with reference to this embodiment.

[0106] In this embodiment, the heat transfer element **824** is in the form of numerous discrete metal pieces (e.g. shavings, disks, chips and/or other shapes) **829** contained within a porous container **831** disposed at a top portion of the working chamber **840**. The metal pieces can be formed from, for example, stainless steel, or another material that provides a high volumetric specific heat as compared to air. The metal pieces configuration of the heat transfer element **824** provides a high surface area per unit volume which the compressed gas contacts as it flows through the porous container **831**, thus resulting in increased heat transfer. Alternatively, instead of being formed of discrete pieces, the heat transfer element can

be formed as a more unitary or interconnected structure, which may not require a container to hold them in a desired position, such as a wool or mesh. The heat transfer element **824** in this embodiment is disposed near one end of the working chamber **840** (i.e. in the portion occupied by the gas near the end of the compression cycle), such that the heat transfer element **824** is exposed to the gas, but not in contact with the liquid, throughout all or most of the compression cycle, including the end when the gas is at or near its maximum temperature as it passes through the heat transfer element **824**. Thus, as the gas is compressed during the compression cycle, and the mechanical work on the air adds heat energy to the gas, the heat energy is continuously transferred (primarily by conductive and/or convective, rather than radiant, heat transfer) to the heat transfer element **824**. This maintains the temperature of the gas at a lower value than would be the case without the heat transfer element **824**, and gradually increases the temperature of the heat transfer element. At the end of the compression cycle, the pressurized gas can be released from the pressure vessel **820**, to the next component in the system **800**. More liquid can then be introduced into the working chamber **840**, to substantially fill the volume occupied by the heat transfer element **824**. The heat energy stored in the heat transfer element **824** can then be transferred (again, by conductive and/or convective transfer) to the liquid in the working chamber **840**. The heat energy may then be transferred out of the pressure vessel by any suitable mechanism.

[0107] FIG. 9 illustrates another embodiment of a compression/expansion device. A compression/expansion device **900** includes a pressure vessel **920** having a working chamber **940**, and a heat transfer element **924** disposed within the working chamber **940**, an actuator **922**, and inlet and outlet conduits **928**, **930** in fluidic communication with the working chamber. The compression/expansion device may also include a piston (not shown) driven by actuator **922**. The pressure vessel **920**, actuator **922**, inlet conduit **928** and outlet conduit **930**, etc. can each be structurally and functionally the same as, or similar to, the pressure vessels, actuators and conduits in other embodiments, and therefore, are not described in detail with reference to this embodiment.

[0108] In this embodiment, the heat transfer element **924** can be disposed within a substantial portion of the working chamber **940** such that gas and liquid can flow through the heat transfer element **924** as the liquid compresses the gas within the working chamber **940**. The heat transfer element **924** can be, for example, discrete pieces held in a container (as described above), or a more unitary structure such as a mesh or wool that is sufficiently porous so as to not materially inhibit the flow of the gas and/or liquid within the working chamber **940**, while at the same time provide high surface area for contact with the gas. In this embodiment, the heat transfer element **924** is in contact with both gas and liquid from the beginning of the compression cycle, with progressively less being exposed to gas, and progressively more being exposed to liquid, as the cycle progresses.

[0109] It is to be understood that the heat transfer elements **824** and **924** can alternatively have other shapes and configurations, while maintaining the properties to function as described. For example, a heat transfer element can be a metal wool configuration (e.g., steel wool or scrubby pads) or other shapes and configurations that provide a high surface area per unit volume for contact with the gas. In some embodiments, a metal mesh configuration as described for heat transfer ele-

ment **924** can be disposed at only a top portion of the working chamber as described for device **800**. Similarly, metal pieces as described for heat transfer element **824** can be disposed in a larger container that occupies a larger portion of the working chamber, similar to the heat transfer element **924**.

[0110] In addition, in other embodiments, a heat transfer element can be positioned at different locations within a pressure vessel than what is shown in FIGS. 8 and 9. In some embodiments, more than one heat transfer element can be used. In such an embodiment, more than one of the same type of heat transfer element can be used, or a combination of different configurations can be used. In addition, within a given compression and expansion system, one or more of the same or different combinations of heat transfer elements can be used in one or more of the pressure vessels of that system.

[0111] FIGS. 10A and 10B illustrate another embodiment of a compression/expansion device. A compression/expansion device **1000** includes a pressure vessel **1020** having a working chamber **1040**, a heat transfer element **1024** disposed within the working chamber **1040**, and a piston **1054** movable within the pressure vessel **1020** to change the volume of the working chamber **1040**. The piston **1054** can be coupled to a suitable actuator (not shown) via a piston rod **1056**. The actuator can be, for example, a hydraulic or pneumatic actuator and can include an electric motor as previously described.

[0112] The compression/expansion device **1000** also includes an inlet conduit **1028** and an outlet conduit **1030** each in fluid communication with the working chamber **1040**. The inlet **1028** can be coupled to a source of gas (e.g., air) and can communicate the gas to the working chamber **1040**. The outlet **1030** can be configured to communicate the gas from the working chamber **1040** to another location. Valves **1036** can be coupled to the inlet **1028** and outlet **1030** and can be operated to open and close the fluid communication to and from the pressure vessel **1020** as described above for previous embodiments.

[0113] As with previous embodiments, the heat transfer element **1024** can be used to remove heat energy from the gas within the pressure vessel **1020** by providing an increased amount of surface area within the pressure vessel **1020** that is in direct contact with the gas being compressed. In this embodiment, the heat transfer element **1024** includes a plurality of vertical fins attached to the pressure vessel **1020**. In other embodiments, the plurality of vertical fins can be attached to the piston **1054**. As the piston **1054** moves in the direction of arrow A during a compression cycle, the gas can flow through the heat transfer element **1024** as the piston **1054** compresses the gas within the working chamber **1040** allowing heat to be transferred from the gas, to the heat transfer element **1024**.

[0114] In some embodiments, the working chamber **1040** can be partially filled with a liquid (e.g., water) that can be communicated to and from the working chamber **1040** via the inlet conduit **1028** and the outlet conduit **1030**, respectively, or via other conduits (not shown). During the compression cycle, heat energy generated during the compression process can be transferred from the gas, to the heat transfer element **1024**, and then to the liquid as flows through the heat transfer element **1024**. A volume of the heated liquid can then be discharged from the pressure vessel **1020** via the outlet conduit **1030** or via a separate liquid discharge conduit (not shown).

[0115] FIGS. 11A and 11B illustrate another embodiment of a compression/expansion device. A compression/expansion device 1100 includes a pressure vessel 1120 having a working chamber 1140, a heat transfer element 1124 disposed within the working chamber 1140, and a piston 1154 movable within the pressure vessel 1120 to change the volume of the working chamber 1140. The piston 1154 can be coupled to a suitable actuator (not shown) via a piston rod 1156. The actuator can be, for example, a hydraulic or pneumatic actuator and can include an electric motor as previously described.

[0116] The compression/expansion device 1100 also includes an inlet conduit 1128 and an outlet conduit 1130 each in fluid communication with the working chamber 1140. The inlet 1128 can be coupled to a source of gas (e.g., air) and can communicate the gas to the working chamber 1140. The outlet 1130 can be configured to communicate the gas from the working chamber 1140 to another location. Valves 1136 can be coupled to the inlet 1128 and outlet 1130 and can be operated to open and close the fluid communication to and from the pressure vessel 1120 as described above for previous embodiments.

[0117] As with previous embodiments, the heat transfer element 1124 can be used to remove heat energy from the gas within the pressure vessel 1120 by providing an increased amount of surface area within the pressure vessel 1120 that is in direct contact with the gas being compressed. In this embodiment, the heat transfer element 1124 includes a plurality of vertical fins attached to both the pressure vessel 1120 and to the piston 1154. As the piston 1154 moves in the direction of arrow A during a compression cycle, the piston 1154 moves the vertical fins attached to the piston 1154 toward the vertical fins attached to the pressure vessel 1120. The fins attached to the pressure vessel 1120 are offset from the fins attached to the piston 1154 such that the fins are interleaved at the end of the compression stroke as shown in FIG. 11B, thereby increasing the effective density of the heat transfer element 1124. Its density is the greatest at the end of the compression stroke of the piston 1154.

[0118] In some embodiments, the working chamber 1140 can be partially filled with a liquid (e.g., water) that can be communicated to and from the working chamber 1140 via the inlet conduit 1128 and the outlet conduit 1130, respectively, or via other conduits (not shown). The interleaving of the two sets of fins reduces the volume of liquid needed to quench the heat transfer element 1124 at the end of a compression cycle. For example, the volume of the liquid in the working chamber 1140 can be reduced such that there is only enough liquid to occupy the interstitial spaces between the fully interleaved sets of fins at the end of the compression stroke. As has been described herein, liquid within the working chamber represents a reduction in the amount of gas that can be compressed or expanded. Thus, it is advantageous to reduce the volume occupied by the heat transfer element and the liquid in order to increase the power density of the device. In some embodiments, the heat transfer element 1124 can be configured such that the volume of liquid in the working chamber 1140 can be reduced by, for example, 50%, 55%, 60%, 65%, 70%, 75%, 80%, 85%, 90%, or 95%.

[0119] During the compression cycle, heat energy generated during the compression process can be transferred from the gas, to the heat transfer element 1124, and then to the liquid as described above for previous embodiments. A volume of the heated liquid can then be discharged from the

pressure vessel 1120 via the outlet conduit 1130 or via a separate liquid discharge conduit (not shown).

[0120] While various embodiments of the invention have been described above, it should be understood that they have been presented by way of example only, and not limitation. Where methods and steps described above indicate certain events occurring in certain order, those of ordinary skill in the art having the benefit of this disclosure would recognize that the ordering of certain steps may be modified and that such modifications are in accordance with the variations of the invention. Additionally, certain of the steps may be performed concurrently in a parallel process when possible, as well as performed sequentially as described above. The embodiments have been particularly shown and described, but it will be understood that various changes in form and details may be made.

[0121] For example, although various embodiments have been described as having particular features and/or combinations of components, other embodiments are possible having any combination or sub-combination of any features and/or components from any of the embodiments described herein. For example, although certain embodiments of a heat transfer element were shown and described with respect to a particular embodiment of a compression/expansion device, it should be understood that the various embodiments of a heat transfer element can be used in any of the various embodiments of a compression and/or expansion device described herein and in other embodiments of a compress and/or expansion device not described herein.

[0122] Additionally, although some embodiments of a compression and/or expansion device include a heat transfer element disposed at a particular location within the pressure vessel, it should be understood that a heat transfer element can be disposed at different locations than those illustrated and described. The specific configurations of the various components of a compression and/or expansion device can also be varied. For example, the size and specific shape of the various components can be different than the embodiments shown, while still providing the functions as described herein.

1-32. (canceled)

33. An apparatus suitable for use in a compressed gas-based energy storage and recovery system, the apparatus comprising:

a pressure vessel having a variable volume working chamber and adapted to contain both a liquid and a gas in direct contact; and

a heat transfer element disposed within the working chamber, wherein the pressure vessel is operable: to compress gas in the working chamber and to transfer heat energy from the compressed gas to the heat transfer element; and to expand high pressure gas in the working chamber and to transfer heat energy from the heat transfer element to the expanded gas.

34. The apparatus of claim 33, further comprising a liquid conduit through which liquid can be introduced into and discharged from the working chamber.

35. The apparatus of claim 34, wherein the pressure vessel is further operable to transfer heat energy from the heat transfer element to liquid in the working chamber.

36. The apparatus of claim 35, wherein the heat energy is transferred from the heat transfer element to the liquid in the working chamber by contacting the liquid with a surface of the heat transfer element.

37. The apparatus of claim **36**, wherein the pressure vessel is further operable to discharge at least a portion of the liquid in the working chamber to remove at least a portion of the heat energy transferred from the heat transfer element to the liquid.

38. The apparatus of claim **34**, wherein the pressure vessel is further operable to compress gas in the working chamber by introducing liquid into the working chamber.

39. The apparatus of claim **38**, wherein the heat transfer element is disposed within a portion of the working chamber such that, as gas is compressed in the working chamber, progressively more of the liquid and less of the gas is exposed to the heat transfer element.

40. The apparatus of claim **33**, wherein the heat transfer element is disposed at an end of the pressure vessel.

41. The apparatus of claim **33**, wherein the heat transfer element is substantially cylindrical.

42. The apparatus of claim **41**, wherein an outer diameter of the heat transfer element is substantially similar to a diameter of the working chamber.

43. The apparatus of claim **42**, wherein a vertical axis of the heat transfer element is parallel to a vertical axis of the working chamber.

44. The apparatus of claim **33**, wherein the heat transfer element comprises at least one of a metal spiral, a plurality of interleaved fins, and a wire mesh.

45. The apparatus of claim **33**, wherein the heat transfer element comprises a plurality of concentric members having annular spaces therebetween, thereby permitting at least one of a gas and a liquid to flow through the annular spaces.

46. The apparatus of claim **33**, wherein the heat transfer element is operable to transfer heat energy received from the compressed gas to an exterior of the working chamber.

47. A method of operating a pressure vessel in a compressed gas-based energy storage and recovery system, the

pressure vessel having a variable volume working chamber and a heat transfer element disposed within the working chamber, the pressure vessel containing both a liquid and a gas in direct contact, the method comprising:

compressing the gas by reducing the volume of the working chamber;

transferring heat energy from the compressed gas to the heat transfer element; and

transferring the heat energy from the heat transfer element to the liquid by contacting a surface of the heat transfer element with the liquid.

48. The method of claim **47**, wherein the step of reducing the volume of the working chamber comprises introducing liquid into the working chamber.

49. The method of claim **47**, further comprising introducing high pressure gas into the working chamber; and

expanding the high pressure gas by increasing the volume of the working chamber and transferring heat energy from the heat transfer element to the expanded gas.

50. The method of claim **49**, wherein the step of increasing the volume of the working chamber comprises discharging liquid from the working chamber.

51. The method of claim **47**, further comprising discharging at least a portion of the liquid in the working chamber to remove at least a portion of the heat energy transferred from the heat transfer element to the liquid.

52. The method of claim **47**, further comprising disposing the heat transfer element within a portion of the working chamber such that, as gas is compressed in the working chamber, progressively more of the liquid and less of the gas is exposed to the heat transfer element.

* * * * *