

(19)



(11)

EP 3 138 739 B1

(12)

EUROPEAN PATENT SPECIFICATION

(45) Date of publication and mention of the grant of the patent:
23.01.2019 Bulletin 2019/04

(51) Int Cl.:
B60R 21/237 ^(2006.01) **B60R 21/207** ^(2006.01)
B60N 2/42 ^(2006.01)

(21) Application number: **15785452.2**

(86) International application number:
PCT/JP2015/060978

(22) Date of filing: **08.04.2015**

(87) International publication number:
WO 2015/166774 (05.11.2015 Gazette 2015/44)

(54) **SIDE AIRBAG APPARATUS FOR VEHICLE**

SEITENAIRBAGVORRICHTUNG FÜR FAHRZEUG

APPAREIL DE COUSSIN DE SÉCURITÉ GONFLABLE LATÉRAL POUR VÉHICULE

(84) Designated Contracting States:
AL AT BE BG CH CY CZ DE DK EE ES FI FR GB GR HR HU IE IS IT LI LT LU LV MC MK MT NL NO PL PT RO RS SE SI SK SM TR

(72) Inventor: **KOBAYASHI Yuto**
Yokohama-shi
Kanagawa 222-8580 (JP)

(30) Priority: **30.04.2014 JP 2014094080**

(74) Representative: **Müller Verweyen**
Patentanwälte
Friedensallee 290
22763 Hamburg (DE)

(43) Date of publication of application:
08.03.2017 Bulletin 2017/10

(73) Proprietor: **Autoliv Development AB**
447 83 Vårgårda (SE)

(56) References cited:
JP-A- H08 142 790 **JP-A- H08 268 206**
JP-A- H11 180 243 **JP-A- 2001 171 468**
JP-A- 2007 216 821 **US-A1- 2008 315 565**
US-A1- 2013 076 013

EP 3 138 739 B1

Note: Within nine months of the publication of the mention of the grant of the European patent in the European Patent Bulletin, any person may give notice to the European Patent Office of opposition to that patent, in accordance with the Implementing Regulations. Notice of opposition shall not be deemed to have been filed until the opposition fee has been paid. (Art. 99(1) European Patent Convention).

Description

[Citation List]

[Technical Field]

[Patent Literature]

[0001] The present invention relates to a vehicle seat comprising a vehicle side airbag device capable of reducing/alleviating the movement of a deployed and inflated side airbag to jerk up the arm of an occupant and improving the occupant restraining performance.

5 **[0006]**

[PTL 1] Japanese Patent Application Publication No. H8-142790

[PTL 2] Japanese Patent Application Publication No. H11-152004

[PTL 3] Japanese Patent Application Publication No. H11-180243

[PTL 4] Japanese Patent Application No. JP 2001 1711468

[Background Art]

[0002] PTL 1 to 4 disclose prior-art techniques related to vehicle side airbag devices, which include taking up a side airbag obliquely with respect to the vertical direction and spreading the side airbag upward in the process of deployment and inflation.

10

15

[Summary of Invention]

[0003] The "airbag device for side collision" disclosed in PTL 1 is aimed to deploy an airbag quickly after detection of a side collision, and the airbag is folded into a long band shape in the deployment direction and in a spirally rolled state while its surface, which is to face the vehicle interior side wall during deployment, is positioned outside, and the airbag is adapted to be deployed forward as its outer side surface is abutted against the vehicle interior side wall and the rolled state is unfolded upon a side collision.

20

25

[Technical Problem]

[0004] The "structure and method for folding an airbag" in PTL 2 is directed to the object of providing a structure and method for folding an airbag that allows improved deployment speed and smooth deployment behavior to be obtained, and here, a head protection portion is rolled a number of times while its protection surface faces inside, the head protection portion is pushed into a chest protection portion, and at this time, part of the chest protection portion coupled to the head protection portion is pushed into the chest protection portion.

30

35

[0007] A side airbag is a countermeasure against a side collision and deployed and inflated toward the vehicle front side between an occupant and a vehicle component, such as a door, that is positioned laterally to the occupant in the vehicle-widthwise direction. In the above-described background art, the side airbag is intended to spread swiftly and smoothly upward. Here, the side airbag may enter below the arm of the occupant or the arm of the occupant may be unintendedly positioned above the side airbag and directly jerked up by the side airbag in a violent, instantaneous manner, which can place an unwanted load upon the occupant and may bring the occupant into an unbalanced position, such that appropriate occupant restraining performance could not be provided.

[0008] The present invention is devised in view of the above-described problem associated with the prior art, and it is an object of the present invention to provide a vehicle seat comprising a vehicle side airbag device capable of reducing/alleviating the movement of a deployed and inflated airbag to jerk up the arm of an occupant and improving the occupant restraining performance.

40

[Solution to Problem]

[0005] The "airbag device for side collision" disclosed in PTL 3 is aimed to provide an airbag device for side collision capable of providing a folded airbag near an upper end of the backrest of a seat without preventing smooth inflation of the airbag, and the airbag device for side collision has the folded airbag on the upper side of the backrest of the seat. The airbag is attached and fixed to the seat frame in a plurality of locations in the vertical direction on the rear edge side and has a lower chamber upstream of inflation gas and an upper chamber provided above the front side of the lower chamber, and the airbag is stored in a folded state and adapted to project forward and deployed upward during inflation. The airbag is provided with radial folding lines around the upper part side of the lower chamber on the rear edge side, and the upper chamber and the lower chamber are folded in a sector shape and stored on the rear edge side of the lower chamber. The side airbag device disclosed in PTL4 comprises an airbag which is stored being folded inward in a roll wound onto the vehicle interior side so as to get close to a base part side from the upper edge side.

45

50

55

[0009] A vehicle seat according to the present invention includes a seat frame and a vehicle side airbag device including a side airbag provided inside the vehicle seat and allowed to be deployed and inflated from the seat into between an occupant and a vehicle component positioned laterally to the occupant in a vehicle-widthwise direction and an inflator attachable to a seat frame of the seat and causing inflator gas to be introduced into the side airbag, the inflator is stored inside the side airbag near a rear end thereof in a deployment and inflation direction, in a spread state, the side airbag has a folded portion with a folding line and a superposed portion in series sequentially from a side of the inflator to a front end thereof in the deployment and inflation direction, in a stored state before deployment, the folded portion is

formed to include an abutment portion in abutment against a support surface of the seat frame during attachment to the seat on a front side of the inflator in a vehicle front-back direction, the superposed portion is formed to be superposed in a rolled state or folded in a bellows-like state to have a lower part wider than an upper part in an up-down direction, and the folded portion is folded to be arranged between the seat frame and the superposed portion in the vehicle-widthwise direction.

[0010] The folded portion is preferably configured to be capable of pushing out the superposed portion toward the vehicle component in the vehicle-widthwise direction upon receiving reaction force from the seat frame during deployment and inflation of the side airbag.

[0011] A vehicle seat according to the present invention includes a seat frame and a vehicle side airbag device including a side airbag provided inside the vehicle seat and allowed to be deployed and inflated from the seat into between an occupant and a vehicle component positioned laterally to the occupant in a vehicle-widthwise direction and an inflator attachable to a seat frame of the seat and causing inflator gas to be introduced into the side airbag, the inflator is stored inside the side airbag near a rear end thereof in a deployment and inflation direction, in a spread state, the side airbag has a folded portion with a folding line and a superposed portion in series sequentially from a side of the inflator to a front end thereof in the deployment and inflation direction, in a stored state before deployment, the folded portion is formed to include an abutment portion in abutment against a support surface of the seat frame during attachment to the seat on a front side of the inflator in a vehicle front-back direction, the superposed portion is formed to be superposed in a rolled state or folded in a bellows-like state to have an upper part wider than a lower part in an up-down direction, and the folded portion is folded to be arranged between the seat frame and the superposed portion in the vehicle-widthwise direction.

[0012] The folded portion is preferably configured to be capable of pushing out the superposed portion toward the vehicle component in the vehicle-widthwise direction upon receiving reaction force from the seat frame during deployment and inflation of the side airbag.

[0013] The vehicle component is desirably a vehicle door or a console box provided on a center side in the vehicle in the vehicle-widthwise direction.

[0014] The side airbag is preferably folded to have an upper part in the up-down direction placed on a lower part before the folded portion and the superposed portion are formed.

[0015] Desirably, the side airbag has an additional folded portion with an additional folding line between the folded portion and the superposed portion; in a stored state before deployment, the additional folded portion is formed to be folded back at least once along the additional folding line to the vehicle rear side from the vehicle front side or conversely in an arrangement parallel to the folded portion; and the superposed portion is arranged

between the additional folded portion and the folded portion in the vehicle-widthwise direction.

[Advantageous Effects of Invention]

[0016] In the vehicle side airbag device of the vehicle seat according to the present invention, the movement of a deployed and inflated side airbag to jerk up the arm of an occupant can be reduced/alleviated and the occupant restraining performance can be improved.

[Brief Description of Drawings]

[0017]

Fig. 1 is a plan view of a vehicle side airbag device according to a preferred embodiment of the present invention showing from above a side airbag in an inflated and deployed state.

Fig. 2 is a view for illustrating a first stage of the assembling procedure of assembling a side airbag into a stored state.

Fig. 3 is a view for illustrating a second stage of the assembling procedure.

Fig. 4 is a view for illustrating a third stage of the assembling procedure.

Fig. 5 is a view for illustrating a fourth stage of the assembling procedure.

Fig. 6 is a view for illustrating a fifth stage of the assembling procedure.

Fig. 7 is a schematic view for illustrating the first half of the assembling procedure described above.

Fig. 8 is a schematic view for illustrating the second half of the assembling procedure described above.

Fig. 9 is a plan view of the side airbag (rolled type) shown in Fig. 1 in a stored state before deployment showing from above how the side airbag is attached to a seat frame.

Fig. 10 is a plan view of the side airbag (bellows-like type) shown in Fig. 1 in a stored state before deployment showing from above how the side airbag is attached to the seat frame.

Fig. 11 is a view for illustrating how the side airbag shown in Fig. 1 is inflated and deployed as viewed from above.

Fig. 12 is a view for illustrating the process of the deployment and inflation of the side airbag shown in Fig. 11 as viewed from the side.

Fig. 13 is a plan view of a modification of the vehicle side airbag device according to the present invention showing from above a side airbag (rolled type) in a stored state before deployment and how the side airbag is attached to a seat frame.

Fig. 14 is a plan view of the modification of the vehicle side airbag device according to the present invention showing from above a side airbag (bellows-like type) in a stored state before deployment and how the side airbag is attached to a seat frame.

Fig. 15 is a view for illustrating how the side airbag in the modification of the vehicle side airbag device according to the present invention is deployed and inflated as viewed from above.

Fig. 16 is a view of another modification of the vehicle side airbag according to the present invention for illustrating a first stage of the assembling procedure of assembling a side airbag into a stored state.

Fig. 17 is a view for illustrating a second stage of the procedure of assembling the side airbag shown in Fig. 16.

Fig. 18 is a view for illustrating a third stage of the procedure of assembling the side airbag shown in Fig. 16.

Fig. 19 is a view for illustrating a fourth stage of the procedure of assembling the side airbag shown in Fig. 16.

Fig. 20 is a view for illustrating a fifth stage of the procedure of assembling the side airbag shown in Fig. 16.

Fig. 21 is a view of the side airbag in Fig. 16 in the process of deployment and inflation as viewed from the side.

[Description of Embodiments]

[0018] Hereinbelow, a vehicle side airbag device according to a preferred embodiment of the present invention will be described in detail with reference to the accompanying drawings. Fig. 1 is a plan view of a side airbag in a vehicle side airbag device according to the embodiment in a deployed and inflated state as viewed from above, Fig. 2 is a view for illustrating a first stage of the assembling procedure of assembling the side airbag shown in Fig. 1 into a stored state, Fig. 3 is a view for illustrating a second stage of the assembling procedure, Fig. 4 is a view for illustrating a third stage of the assembling procedure, Fig. 5 is a view for illustrating a fourth stage of the assembling procedure, Fig. 6 is a view for illustrating a fifth stage of the assembling procedure, Fig. 7 is a schematic view for illustrating the first half of the assembling procedure described above, Fig. 8 is a schematic view for illustrating the second half of the assembling procedure described above, Fig. 9 is a plan view of the side airbag (rolled type) shown in Fig. 1 in a stored state before deployment showing from above how the side airbag is attached to a seat frame, Fig. 10 is a plan view of the side airbag (bellows-like type) shown in Fig. 1 in a stored state before deployment showing from above how the side airbag is attached to the seat frame, Fig. 11 is a view for illustrating how the side airbag shown in Fig. 1 is inflated and deployed as viewed from above, and Fig. 12 is a view for illustrating the side airbag shown in Fig. 11 in the process of the deployment and inflation as viewed from the side.

[0019] As shown in Fig. 1, a side airbag 2 in a vehicle side airbag device 1 is provided inside a seat back 3a of a seat 3 provided in a vehicle as the airbag is stored in

a rolled up or collapsed state before deployment and inflation. An occupant P is seated at the seat 3. On both the left and right sides of the seat 3 in the vehicle-widthwise direction, vehicle components such as a door 4 (on the vehicle exterior side) and a console box 5 (on the vehicle interior side) on the center side in the vehicle-widthwise direction are provided in lateral positions to the occupant P in the vehicle-widthwise direction, in other words, in positions facing the sides of the occupant P.

[0020] As has been well known, in response to an impact upon the vehicle caused by a side collision for example, the side airbag 2 is deployable and inflatable from the seat back 3a to the front side of the seat 3, in other words, forward in the front-back lengthwise direction of the vehicle (hereinafter as the vehicle front-back direction), into between the occupant P and the vehicle component such as the door 4 and the console box 5 positioned laterally to the occupant P in the vehicle-widthwise direction. Therefore, as shown in Fig. 2, the part of the side airbag 2 on the side of the seat back 3a (the vehicle rear side) corresponds to the rear end side in the deployment and inflation direction, and the vehicle front side corresponds to the front end side in the deployment and inflation direction.

[0021] The deployment and inflation of the side airbag 2 from its stored state is achieved by introduction of inflator gas from an inflator 6 into the side airbag 2. The side airbag 2 is normally deployed and inflated in a range from the hips of the occupant P to above the head, restrains the occupant P toward the seat 3, blocks the vehicle component such as the door 4 from the occupant P to protect the occupant P, and reduces the injury value for the occupant P.

[0022] A firm seat frame 7 for receiving and supporting the body of the occupant P or the like resting thereupon is provided in the seat back 3a. As shown in Fig. 9, the seat frame 7 is a frame including a channel member or a square tube. The seat frame 7 has a plane portion facing the side of the vehicle component such as the door 4, and according to the embodiment, the plane portion forms a support surface 7a used to attach the inflator 6 or support the side airbag 2 to be deployed and inflated. Therefore, the inflator 6 can be attached to the seat 3, for example at the seat frame 7.

[0023] Stud bolts 8 are provided integrally on one side of the inflator 6 and fixed by nuts 9 to the support surface 7a of the seat frame 7 inside the seat back 3a. The inflator 6 is attached to the support surface 7a of the seat frame 7 as the stud bolts 8 are fixed to the seat frame 7. The inflator 6 is stored in the side airbag 2. The storing position of the inflator 6 is set near the rear end of the side airbag 2 in the deployment and inflation direction.

[0024] The inflator 6 stored in the side airbag 2 is attached to the seat frame 7, so that the part of the side airbag 2 near the rear end in the deployment and inflation direction is fixed to the seat frame 7. Since the inflator 6 is stored in the side airbag 2, inflator gas ejected from the inflator 6 fills up the side airbag 2 to deploy and inflate

the side airbag 2.

[0025] Now, the assembling procedure of assembling the side airbag 2 into a stored state will be described. Fig. 2 shows the side airbag 2 in a flat spread out state. In the figure, the upward direction corresponds to the upward direction in the vehicle up-down height-wise direction (hereinafter referred to as the height-wise direction), the downward direction corresponds to the downward direction in the height-wise direction, the leftward corresponds to the front end side in the deployment and inflation direction (the vehicle front side), and the rightward corresponds to the rear end side in the deployment and inflation direction (the vehicle rear side).

[0026] In a well-known manner, the side airbag 2 is formed into a bag shape having an opening portion 2a by placing two sheets of ground fabric on each other or folding a sheet of ground fabric and placing the folds upon each other and then stitching the peripheries together to join them.

[0027] In the illustrated side airbag 2, the opening portion 2a is formed to protrude to the vehicle rear side toward the rear end in the deployment and inflation direction (hereinafter referred to as the rear end in the deployment direction). The inflator 6 is stored inside the side airbag 2 through the opening portion 2a. The stud bolts 8 protrude outwardly from the side airbag 2 through bolt holes formed at the side airbag 2. Note that 10 designates a harness.

[0028] According to the embodiment, the external shape of the side airbag 2 has a larger size in the vehicle up-down direction than its length in the vehicle front-back direction. The side airbag 2 is generally directed obliquely upward from the storing position of the inflator 6 to the front side in the vehicle front-back direction.

[0029] Stated differently, when the side airbag 2 is observed as it is separated in the height-wise direction into a lower part 2b corresponding to a height-wise range in which the inflator 6 is stored (which corresponds to the height of the door belt line and its vicinity in the vehicle) and an upper part 2c corresponding to a height-wise range beyond the inflator 6 (which corresponds to the side window position in the vehicle), the upper part 2c is formed to be directed obliquely upward to the front side in the vehicle front-back direction.

[0030] If the side airbag 2 is formed into this shape, the region from the hips to the head of the occupant P that can move forward in the vehicle and outward in the vehicle-widthwise direction upon a side collision or the like can be received and restrained by the entire side airbag 2 and protected.

[0031] Then, as shown in Fig. 3, the opening portion 2a of the side airbag 2 is folded back to the front end in the deployment and inflation direction (hereinafter referred to as the front end in the deployment direction) and is partly placed on the lower part 2b of the side airbag 2 so that the opening portion overlaps the storing position of the inflator 6. The opening portion 2a has through holes 11 through which the stud bolts 8 protruding from the

side airbag 2 are passed (see Fig. 2). Therefore, the opening portion 2a is placed on the lower part 2b of the side airbag 2 to face the support surface 7a of the seat frame 7.

[0032] Then, as shown in Fig. 4, the side airbag 2 is folded downward so that the upper part 2c is placed on the lower part 2b. In the illustrated example, the upper part 2c is placed on the lower part 2b of the side airbag 2 on the opposite side to the side to which the opening portion 2a is folded, in other words, the upper part is placed to face the vehicle component such as the door 4 and the console box 5. In this way, the side airbag 2 in an external shape having a larger size in the height-wise direction can be stored in a compact shape with a reduced height.

[0033] Then, as shown in Fig. 5, the part of the side airbag 2 on the vehicle front side ahead of the storing position of the inflator 6 (the part to be the front end in the deployment and inflation direction) is folded back to the vehicle rear side (the rear end side in the deployment and inflation direction) along a folding line F1 set at the front end of the front extended part extended to the vehicle front side beyond the stored position of the inflator 6. An abutment portion Q in abutment against the support surface 7a of the seat frame 7 is set at the extended portion from the stored position of the inflator 6 to the folding line F1 on the vehicle front side of the inflator 6 in the vehicle front-back direction.

[0034] For the ease of description, the description will continue with reference to Fig. 7 and Fig. 8 showing the side airbag 2 in a rectangular shape having a greater length in the vehicle front-back direction. Fig. 7(a) substantially corresponds to Fig. 2 and Fig. 3 and shows the side airbag 2 storing the inflator 6 in a flat spread out state. In the following description, the manner of folding the upper part 2c of the side airbag 2 on the lower part 2b described in conjunction with Fig. 4 is omitted.

[0035] In the flat spread out state, the side airbag 2 has a folded portion X1 with a folding line F1 and a superposed portion S rolled or folded in a bellows-like shape in series sequentially from the side of the inflator 6 (on the rear end side in the deployment direction) to the front end in the deployment direction.

[0036] To be more specific, the folded portion X1 corresponds to a region folded along the folding line F1 at the front end of the front extended portion from the stored position of the inflator 6, and the front extended portion that forms the folded portion X1 includes the abutment portion Q in abutment against the seat frame 7 or the support surface 7a of the seat frame 7 to be specific when the side airbag 2 is attached to the seat 3.

[0037] Fig. 7(b-1) corresponds to Fig. 5. As described in conjunction with Fig. 5, the position of the folding line F1 is set on the vehicle front side ahead of the stored position of the inflator 6. In the illustrated example of the side airbag 2, the airbag is folded back to the vehicle rear side from the vehicle front side along the folding line F1 on the front side of the inflator 6 in the vehicle front-back

direction, so that the entire side airbag is extended to the rear side of the vehicle excluding the abutment portion Q.

[0038] The folded portion X1 is provided in a location between the support surface 7a of the seat frame 7 and the vehicle component such as the door 4 and the console box 5. In the meantime, the superposed portion S is extended on the vehicle rear side behind the folded portion X1 by the folding line F1. When the folding line F1 is set on the vehicle rear side behind the storing position of the inflator 6 and the side airbag 2 is folded to the vehicle front side from the vehicle rear side, the superposed portion S is extended to the vehicle front side ahead of the folded portion X1.

[0039] In the illustrated example, the folding line F1 is formed slightly obliquely with respect to the vehicle front-back direction so that the upper end side of the side airbag 2 in the height-wise direction is folded in a position more on the vehicle rear side and the lower end side in the height-wise direction is folded in a position more on the vehicle front side. In this way, the superposed portion S has a substantially trapezoidal outer shape.

[0040] When the folded side airbag 2 is observed from above, the superposed portion S continuous with the folded portion X1 is positioned to overlap the inflator 6 in the side airbag 2 as shown in Fig. 7(b-2).

[0041] The superposed portion S is superposed in a rolled state or folded in a bellows-like state. As shown in Fig. 7(c), as for the shape of the superposed portion S, the circumference D for taking up or the interval D for folding is reduced on the upper side of the side airbag 2 and widened on the lower side so that the lower side of the side airbag 2 in the height-wise direction is wider than the upper side during superposition.

[0042] Therefore, as shown in Fig. 8 (a), when the side airbag 2 is in a stored state after the superposed portion S is formed, the superposed portion S is placed on the abutment portion Q of the folded portion X1 in the vehicle-widthwise direction, while as shown in Fig. 8(b), when the superposed portion S is in a rolled state, the upper side has a small radius (R1), and the lower side is loosely rolled to have a large radius (R2) as shown in Fig. 8(c) and Fig. 8(d), so that the side airbag is formed into a circular truncated cone (cone shape) tapered upward and made longer in the vertical direction. As can be understood from the stored state, the side airbag 2 has, in series, an extended portion extended generally flatly from the stored position of the inflator 6 and including the abutment portion Q, the folding line F1 at the front end of the extended portion, and the superposed portion S extended from the folding line F1 to the front end in the deployment and inflation direction, so that the superposed portion S is placed on the extended portion (abutment portion Q) by the folding line F1 virtually along the folding line F1 as the boundary.

[0043] When the superposed portion S is folded in a bellows-like shape, the upper side is narrow (W1) and the lower side is wide (W2) as shown in Fig. 8(e), so that the portion is formed into a trapezoidal shape tapered

upward and made longer in the vertical direction.

[0044] When the length from the inflator 6 to the folding line F1 is shorter than the above-described larger sizes (R2 and W2) of the superposed portion S and the folded portion X1 is deployed and inflated, the superposed portion S might roll and fall off from the support surface 7a rather than in the vehicle-widthwise direction. Therefore, the length from the inflator 6 to the folding line F1 is preferably set to about the same size as the above-described sizes (R2 and W2) of the superposed portion S.

[0045] As in the foregoing, the side airbag 2 is arranged in the stored state as shown in Fig. 6 that corresponds to Fig. 8 (a) . The superposed portion S that is wider on the lower side (which is loosely rolled or widely folded) than the upper side allows the lower side of the side airbag 2 to be smoothly and swiftly deployed from the seat back 3a toward the vehicle front side during deployment and inflation of the side airbag 2, so that the upper side of the superposed portion S is unfolded by the deployment of the lower side of the side airbag 2, immediately followed by deployment of the upper side of the side airbag 2.

[0046] As shown in Fig. 9 and Fig. 10, the side airbag 2 in the stored state is provided in the seat back 3a by fixing the stud bolts 8 of the inflator 6 to the seat frame 7 and attaching the inflator 6 to the seat frame 7. In the stored state of the side airbag 2 having the inflator 6 provided inside, the folded portion X1 is arranged between the support surface 7a of the seat frame 7 and the superposed portion S while it is directed in the vehicle-widthwise direction in which the vehicle component such as the door 4 and the console box 5 is positioned. More specifically, the folded portion X1 is folded to be arranged between the seat frame 7 and the superposed portion S in the vehicle-widthwise direction.

[0047] The folded portion X1 is configured to be capable of pushing out the superposed portion S toward the vehicle component such as the door 4 and the console box 5 in the vehicle-widthwise direction upon receiving reaction force from the seat frame 7 during deployment and inflation of the side airbag 2. Stated differently, the folded portion X1 is configured to be inflated at the support surface 7a of the seat frame 7 by introduced inflator gas and push out the superposed portion S toward the vehicle component such as the door 4 and the console box 5 in the vehicle-widthwise direction.

[0048] Now, the operation of the vehicle side airbag device 1 according to the embodiment will be described. The following description is about the operation on the side of the door 4 but equally applies to the operation on the side of the console box 5.

[0049] As shown in Fig. 11 and Fig. 12, the side airbag 2 that stores the inflator 6 attached to the support surface 7a of the seat frame 7 using the stud bolts 8 is provided in a stored state inside the seat back 3a. The inflator 6 is activated in response to a side collision for example to eject inflator gas into the side airbag 2, and then the side airbag 2 is made to jump out through the opening formed

at the seat back 3a and deployed and inflated.

[0050] In an initial stage of the deployment and inflation of the side airbag 2, the folded portion X1 folded along the folding line F1 is filled up with the inflator gas. The folded portion X1 has the abutment portion Q placed on the support surface 7a of the seat frame 7 and is inflated in the vehicle-widthwise direction or toward the side of the door 4 as the vehicle component as the portion bears on the support surface 7a during inflation.

[0051] The folded portion X1 is also positioned between the support surface 7a of the seat frame 7 and the superposed portion S in the vehicle-widthwise direction, and therefore the folded portion X1 inflated toward the door 4 as indicated by the double-dots chain line Z1 pushes out the superposed portion S toward the door 4 (see the arrow T1) .

[0052] The inflator gas introduced into the folded portion X1 is further introduced into the superposed portion S. The superposed portion S is deployed and inflated by the introduced inflator gas while being pressed against the door 4 by the folded portion X1. The lower side of the side airbag 2 precedes the upper side of the side airbag 2 in the deployment and inflation of the superposed portion S because of the rolled or bellows-like superposed state.

[0053] The preceding lower side of the side airbag 2 is instantaneously deployed and inflated to the vehicle front side from the side of the seat back 3a along the door 4 while being pressed against the door 4 by the folded portion X1. As indicated by the two-dot chain line Z2, when the lower side of the side airbag 2 is deployed and inflated, the relatively tightly rolled or folded upper side of the superposed portion or the upper side of the side airbag 2 is unfolded in response to the movement to be deployed and inflated to the vehicle front side from the side of the seat back 3a as the inflator gas is introduced.

[0054] As shown in Fig. 4, when the upper part 2c of the side airbag 2 in the up-down direction is folded and placed on the lower part 2b before the folded portion X1 and the superposed portion S are formed, the upper part 2c is deployed and inflated more upward than the lower part 2b in the process of deployment and inflation of the superposed portion S.

[0055] Therefore, as indicated by the solid line Z3, the lower part 2b of the side airbag 2 is deployed and inflated facing the door 4 and the upper part 2c is directed obliquely upward during deployment and inflation so that the upper part 2c faces the side window or the like. The operation can be similarly ensured for the vehicle side airbag device 1 provided on the side of the console box 5.

[0056] As described in conjunction of the background art, as the side airbag 2 is deployed and inflated, the side airbag could enter below the arm of an occupant or the arm of an occupant could be unintendedly positioned above the side airbag, and the arm of the occupant could be violently and instantaneously jerked up by the side airbag.

[0057] In contrast, in the vehicle side airbag device 1

according to embodiment, the superposed portion S deployed and inflated to the vehicle front side is pushed out and pressed against the door 4 or the console box 5 by the folded portion X1, so that the superposed portion S can be deployed and inflated to the vehicle front side while avoiding the position of the arm of the occupant P.

[0058] Since the upper side of the side airbag 2 is gradually unfolded to be deployed and inflated from the rolled or bellows-like folded state succeeding the deployment and inflation of the lower side of the side airbag 2, so that the superposed portion S lifts up the arm of the occupant P rather than violently and instantaneously jerking up the arm of the occupant P and the side airbag 2 can be directed obliquely upward during deployment and inflation.

[0059] Therefore, appropriate occupant restraining performance can be ensured without placing an unwanted load upon the occupant P and bringing the occupant P into an unbalanced position. The side airbag 2 can be deployed and inflated in a height range from the hips of the occupant P to above the head and receive the chest and side of the occupant P from under the lifted arm to surely restrain the occupant P to the side of the seat 3, while at the same blocking and protecting the occupant P from the vehicle component such as the door 4 and the console box 5, so that the injury value for the occupant P can be reduced.

[0060] As in the foregoing, the vehicle side airbag device 1 according to the embodiment can alleviate and reduce the movement of the side airbag 2 to jerk up the arm of the occupant P during deployment and inflation, so that the occupant restraining performance can be improved.

[0061] Fig. 13 to Fig. 15 show a modification of the above-described embodiment. Fig. 13 is a view of a side airbag (rolled type) according to the modification in a stored state before deployment showing from above how the side airbag is attached to a seat frame, Fig. 14 a view of a side airbag (bellows-like type) according to the modification in a stored state before deployment showing from above how the side airbag is attached to a seat frame, and Fig. 15 is a view of the side airbag according to the modification showing from above how the side airbag is deployed and inflated.

[0062] As shown in Fig. 13 and 14, according to the modification, the side airbag 2 has a folded portion X1, an additional folded portion X2 with an additional folding line F2, and a superposed portion S in series sequentially from the side of the inflator 6 to its front end in a flat spread out state. More specifically, the additional folded portion X2 is provided between the folded portion X1 and the superposed portion S.

[0063] The superposed portion S is arranged between the additional folded portion X2 and the folded portion X1 in the vehicle-widthwise direction in the stored state before deployment because of the additional folded portion X2. More specifically, the additional folded portion X2 is positioned outside of the superposed portion S in the vehicle-widthwise direction. The additional folded

portion X2 faces the vehicle component such as the door 4 and the console box 5.

[0064] The superposed portion S is interposed between the additional folded portion X2 and the folded portion X1, and the additional folded portion is inflated by inflator gas introduced through the folded portion X1, supports the superposed portion S to be pushed out in the vehicle-widthwise direction by the inflation of the folded portion X1 from the opposite side (on the side of the door 4 or the console box 5) to the folded portion X1 (on the side of the inflator 6 and the seat frame 7) and thus directs the deployment and inflation direction of the superposed portion S laterally to the occupant P.

[0065] The additional folded portion X2 is formed by setting the additional folding line F2 in a location of the superposed portion S connected to the folded portion X1. The additional folding line F2 causes the direction of rolling or folding the superposed portion S to be reversed from the above-described embodiment (see Fig. 9 and Fig. 10). The additional folded portion X2 is continuous to both the superposed portion S and the folded portion X1 as described above and connected to the folded portion X1 by detouring to surround almost half around the outer side of the superposed portion S from the vehicle rear side (indicated by Y).

[0066] The folding line F1 of the folded portion X1 and the additional folding line F2 of the additional folded portion X2 are set on the same side with respect to the inflator 6 in the vehicle front-back direction. The additional folded portion X2 and the folded portion X1 are set in a parallel arrangement to each other in the vehicle front-back direction.

[0067] The additional folded portion X2 may be folded to the opposite direction from the above or forward from the vehicle rear side to be specific if the superposed portion S is positioned between the additional folded portion X2 and the folded portion X1. In the illustrated example, the additional folded portion X2 is folded once but a plurality of such additional folded portion X2 may be formed by folding back a number of times, so that the plurality of additional folds X2 are placed upon one another.

[0068] The additional folded portion X2 is positioned parallel to the support surface 7a of the seat frame 7 and provided in a position between the inflator 6 or the folded portion X1 and the vehicle component such as the door 4 and the console box 5.

[0069] As indicated by the double-dots chain line Z1 in Fig. 15, in an early stage of the deployment and inflation of the side airbag 2, the folded portion X1 is inflated by inflator gas filled up inside and pushes out the superposed portion S and the additional folded portion X2 toward the door 4 (see the arrow T2). The inflator gas from the folded portion X1 is further introduced into the additional folded portion X2 through the folded portion X1, and the additional folded portion X2 is inflated.

[0070] The additional folded portion X2 is placed on the vehicle component such as the door 4 and the console box 5 and inflated in the vehicle widthwise direction

or toward the support surface 7a of the seat frame 7 (toward the seat back 3a) by bearing on the vehicle component during inflation. The additional folded portion X2 is also arranged between the vehicle component (4, 5) and the superposed portion S in the vehicle widthwise direction, so that the additional folded portion X2 inflated toward the support surface 7a of the seat frame 7 presses the superposed portion S toward the support surface 7a of the seat frame 7 (see the arrow T3).

[0071] Furthermore, the additional folded portion X2 is connected to the folded portion X1 by detouring to surround the superposed portion S from the vehicle rear side and inflated by distribution of the inflator gas, so that the superposed portion S is pushed out toward the vehicle front side from between the folded portion X1 and the additional folded portion X2 (see the arrow T4).

[0072] In the modification, the additional folded portion X2 allows the superposed portion S to be appropriately guided toward the vehicle front side in the deployment and inflation direction. The entire side airbag 2 can be deployed and inflated more closely to the occupant P than the case of providing the folded portion X1 only, so that the effect of receiving the occupant P can be improved. The effect can be equally ensured for the vehicle side airbag device 1 provided on the side of the console box 5.

[0073] Then, when the inflator gas is introduced into the superposed portion S from the additional folded portion X2, the lower side of the side airbag 2 is deployed and inflated as indicated by the two-dot chain line Z2, and the relatively tightly rolled or folded upper side of the superposed portion or the upper side of the side airbag 2 is unfolded following the above-described movement and deployed and inflated toward the vehicle front side from the side of seat back 3a as the inflator gas is introduced.

[0074] Then, as indicated by the solid line Z3, the lower part 2b of the side airbag 2 is deployed and inflated facing the door 4, and the upper part 2c is directed obliquely upward facing the side window or the like to be deployed and inflated similarly to the above-described embodiment. It is understood that even in the modification, the advantageous effects equal to the above-described embodiments are provided.

[0075] Fig. 16 to Fig. 21 show a side airbag device according to a modification of the embodiment of the present invention. Fig. 16 is a view for illustrating a first stage of the assembling procedure of assembling a side airbag into a stored state, Fig. 17 is a view for illustrating a second stage of the assembling procedure, Fig. 18 is a view for illustrating a third stage of the assembling procedure, Fig. 19 is a view for illustrating a fourth stage of the assembling procedure, Fig. 20 is a view for illustrating a fifth stage of the assembling procedure, and Fig. 21 is a view for illustrating the process of how the side airbag according to the modification is deployed and inflated as viewed from the side. The following description will center on differences from the above-described embodiment.

[0076] According to the modification, the side airbag 2 has its upper part 2e deployed and inflated around the side window and the door 4 as indicated by the solid line Z5 in Fig. 21, and its lower part 2d directed obliquely downward to face the door 4 below the side window and to be deployed and inflated.

[0077] As shown in Fig. 16, when the side airbag 2 is observed as it is separated in the height-wise direction into the upper part 2e corresponding to the height-wise range in which the inflator 6 is stored (which corresponds to the height of the vehicle door belt line and the vicinity) and the lower part 2d corresponding to the height-wise range below the inflator 6 (which corresponds to the position of the vehicle door 4), the lower part 2d is formed to be directed obliquely downward to the front side in the vehicle front-back direction.

[0078] As shown in Fig. 17, the opening portion 2a of the side airbag 2 is folded back to the front end in the deployment and inflation direction (hereinafter referred to as the front end in the deployment direction) to overlap the stored position of the inflator 6 and partly placed on the upper part 2e of the side airbag 2. The opening portion 2a is placed on the upper part 2e of the side airbag 2 to face the support surface 7a of the seat frame 7.

[0079] Then, as shown in Fig. 18, the side airbag 2 has its lower part 2d folded upward to be placed on the upper part 2e. In the illustrated example, the lower part 2d is placed on the upper part 2e of the side airbag 2 on the opposite side to the side on which the opening portion 2a is folded back or placed to face the vehicle component such as the door 4 and the console box 5.

[0080] Then, as shown in Fig. 19, the side airbag 2 has a part on the vehicle front side ahead of the stored position of the inflator 6 (the portion to be the front end in the deployment and inflation direction) that is folded back to the rear side of the vehicle (the rear end side in the deployment and inflation direction) along the folding line F1 set at the front end of the front extended portion extended toward the vehicle front side ahead of the stored position of the inflator 6. The extended portion between the stored position of the inflator 6 and the folding line F1 has the abutment portion Q in abutment against the support surface 7a of the seat frame 7 positioned ahead of the inflator 6 in the vehicle front-back direction.

[0081] Then, as shown in Fig. 20, after the procedure described in conjunction with Fig. 7 and Fig. 8 related to the above-described embodiment, the side airbag 2 attains a store state. The superposed portion S having an upper side wider (more loosely rolled or widely folded) than a lower side allows the upper side of the side airbag 2 to be smoothly and swiftly deployed toward the vehicle front side from the seat back 3a during deployment and inflation of the side airbag 2, so that the lower side of the superposed portion S is unfolded by the deployment of the upper side of the side airbag 2, immediately followed by the deployment of the lower side of the side airbag 2.

[0082] In the deploying and inflating behavior according to the modification, the superposed portion S is de-

ployed and inflated so that the upper side of the side airbag 2 is deployed and inflated first because of the rolled or bellows-like superposed state described above, and then the lower side of the side airbag 2 is deployed and inflated.

[0083] The preceding upper side of the side airbag 2 is instantaneously deployed and inflated along the door 4 from the side of the seat back 3a to the vehicle front side while being pressed against the door 4 by the folded portion X1. As indicated by the single-dot chain line Z4, when the upper side of the side airbag 2 is deployed and inflated, the relatively tightly rolled or folded lower side of the superposed portion or the lower side of the side airbag 2 follows the movement and is unfolded as the inflator gas is introduced therein and deployed and inflated toward the vehicle front side from the side of the seat back 3a.

[0084] As shown in Fig. 18, when the lower part 2d in the up-down direction of the side airbag 2 is folded to be placed on the upper part 2e before the folded portion X1 and the superposed portion S are formed, the lower part 2d is deployed and inflated upward with relative to the upper part 2e in the process of deployment and inflation of the superposed portion S.

[0085] Therefore, as indicated by the solid line Z5, the side airbag 2 has its upper part 2e deployed and inflated facing the side window and the door 4 in the vicinity and its lower part 2d directed obliquely downward to face the door 4 during deployment and inflation. The effects can be equally ensured for the vehicle side airbag device 1 provided on the side of the console box 5.

[0086] As for the superposed portion S, the lower side of the side airbag 2 is gradually unfolded from the rolled or bellows-like shape and deployed and inflated following the deployment and inflation of the upper side of the side airbag 2, so that the side airbag 2 is directed downward during deployment and inflation.

[0087] According to the modification, the side airbag 2 can be deployed and inflated downward at sufficiently satisfactory deployment speed while the property of how the side airbag 2 can be stored in the seat back 3a is secured.

[0088] It is understood that even in the modification, the advantageous effects equal to the above-described embodiment can be provided.

[0089] The vehicle side airbag devices as described above are preferred embodiments of the present invention, and other embodiments can be carried out or implemented in various other ways. In particular, the invention is not limited by details of the shapes, sizes, arrangements, and the like of the components shown in the accompanying drawings unless otherwise specified herein. The expressions and terms herein are used for the purpose of description and should not be taken as limiting unless otherwise specified.

[Reference Signs List]

[0090]

1	Vehicle side airbag device	5
2	Side airbag	
2b	Lower part of side airbag	
2c	Upper part of side airbag	
2d	Lower part of side airbag	
2e	Upper part of side airbag	10
3	Seat	
4	Door	
5	Console box	
6	Inflator	
7	Seat frame	15
7a	Support surface	
F1	Folding line	
F2	Additional folding line	
P	Occupant	
Q	Abutment portion	20
S	Superposed portion	
X1	Folded portion	
X2	Additional folded portion	25

Claims

1. A vehicle seat (3) comprising a seat frame (7) and a vehicle side airbag device (1), comprising:

a side airbag (2) provided inside a vehicle seat (3) and allowed to be deployed and inflated from the seat (3) into between an occupant (P) and a vehicle component positioned laterally to the occupant (P) in a vehicle-widthwise direction; and
 an inflator (6) attached to a seat frame (7) of the seat (3) and causing inflator gas to be introduced into the side airbag (2),
 the inflator (6) being stored inside the side airbag (2) near a rear end thereof in a deployment and inflation direction,
 in a spread state, the side airbag (2) has a lower part (2b) and an upper part (2c) to be folded and placed on the lower part (2b), the upper part (2c) is formed obliquely upward to the front side in the vehicle front-back direction, and
 after the upper part (2c) is folded and placed on the lower part (2b), the side airbag has a folded portion (X1) with a folding line (F1) and a superposed portion (S) in series sequentially from a side of the inflator (6) to a front end thereof in the deployment and inflation direction, in a stored state before deployment, the folded portion (X1) being formed to include an abutment portion (Q) in abutment against a support surface (7a) of the seat frame (7) during attachment to the seat (3) on a front side of the inflator (6)

in a vehicle front-back direction, the superposed portion (S) being formed to be superposed on the folded portion (X1) in a rolled state or collapsed in a bellows-like state so as to have a lower side wider than an upper side in an up-down direction,
 the folded portion (X1) being folded to be arranged between the seat frame (7) and the superposed portion (S) in the vehicle-widthwise direction.

2. The vehicle seat of claim 1, wherein the folded portion (X1) is configured to be capable of pushing out the superposed portion (S) toward the vehicle component in the vehicle-widthwise direction upon receiving reaction force from the seat frame (7) during deployment and inflation of the side airbag (2) .
3. A vehicle seat (3) comprising a seat frame (7) and a vehicle side airbag device (1), comprising:

a side airbag (2) provided inside a vehicle seat (3) and allowed to be deployed and inflated from the seat (3) into between an occupant (P) and a vehicle component positioned laterally to the occupant (P) in a vehicle-widthwise direction; and
 an inflator (6) attached to a seat frame (7) of the seat (3) and causing inflator gas to be introduced into the side airbag (2),
 the inflator (6) being stored inside the side airbag (2) near a rear end thereof in a deployment and inflation direction,
 in a spread state, the side airbag (2) has an upper part (2e) and a lower part (2d) to be folded and placed on the upper part (2e), the lower part (2d) is formed obliquely downward to the front side in the vehicle front-back direction, and after the lower part (2d) is folded and placed on the upper part (2e), the side airbag has a folded portion (X1) with a folding line (F1) and a superposed portion (S) in series sequentially from a side of the inflator (6) to a front end thereof in the deployment and inflation direction, in a stored state before deployment, the folded portion (X1) being formed to include an abutment portion (Q) in abutment against a support surface (7a) of the seat frame (7) during attachment to the seat (3) on a front side of the inflator (6)
 in a vehicle front-back direction, the superposed portion (S) being formed to be superposed on the folded portion (X1) in a rolled state or collapsed in a bellows-like state so as to have an upper side wider than a lower side in an up-down direction,
 the folded portion (X1) being folded to be arranged between the seat frame (7) and the superposed portion (S) in the vehicle-widthwise di-

rection.

4. The vehicle seat of claim 3, wherein the folded portion (X1) is configured to be capable of pushing out the superposed portion (S) toward the vehicle component in the vehicle-widthwise direction upon receiving reaction force from the seat frame (7) during deployment and inflation of the side airbag (2) .
5. The vehicle seat of any one of claims 1 to 4, wherein the vehicle component is a vehicle door.
6. The seat of any one of claims 1 to 4, wherein the vehicle component is a console box provided on a center side in the vehicle in the vehicle-widthwise direction.
7. The vehicle seat of any one of claims 1 to 6, wherein the side airbag (2) is folded to have an upper part (2c) in the up-down direction placed on a lower part (2b) before the folded portion (X1) and the superposed portion (S) are formed.
8. The vehicle seat of any one of claims 1 to 7, wherein in a spread state, the side airbag (2) has an additional folded portion (X2) with an additional folding line (F2) between the folded portion (X1) and the superposed portion (S), in a stored state before deployment, the additional folded portion (X2) is formed to be folded back at least once along the additional folding (F2) line to the vehicle rear side from the vehicle front side or conversely in an arrangement parallel to the folded portion (F1), and the superposed portion (S) is arranged between the additional folded portion (X2) and the folded portion (X1) in the vehicle-widthwise direction.

Patentansprüche

1. Ein Fahrzeugsitz (3) umfassend einen Sitzrahmen (7) und eine Fahrzeug-Seitenairbagvorrichtung (1), umfassend:

einen Seitenairbag (2), der im Inneren eines Fahrzeugsitzes (3) bereitgestellt ist und von dem Sitz (3) aus zwischen einem Insassen (P) und einer Fahrzeugkomponente, die seitlich zu dem Insassen (P) in einer Fahrzeug-Breitenrichtung positioniert ist, ausgelöst und aufgeblasen werden kann; und

einen Gasgenerator (6), der an einem Sitzrahmen (7) des Sitzes (3) befestigt ist und bewirkt, dass Gasgeneratorgas in den Seitenairbag (2) eingeführt wird,

wobei der Gasgenerator (6) im Inneren des Seitenairbags (2) nahe einem hinteren Ende in Auslöse- und Aufblasrichtung verstaut ist,

in einem ausgebreiteten Zustand weist der Seitenairbag (2) einen Unterteil (2b) und einen Oberteil (2c) auf, der auf dem Unterteil (2b) zu falten und zu platzieren ist, wobei der Oberteil (2c) schräg nach oben zu der Vorderseite in der Vorne-Hinten-Richtung des Fahrzeugs ausgebildet ist, und

nachdem der Oberteil (2c) gefaltet und auf dem Unterteil (2b) platziert worden ist, weist der Seitenairbag einen gefalteten Abschnitt (X1) mit einer Falllinie (F1) und einen überlappenden Abschnitt (S) in Reihe aufeinanderfolgend von einer Seite des Gasgenerators (6) zu einem vorderen Ende davon in der Auslöse- und Aufblasrichtung in einem verstaute Zustand vor der Auslösung auf, wobei der gefaltete Abschnitt (X1) geformt ist, um einen Anlageabschnitt (Q) in Anlage an einer Stützfläche (7a) des Sitzrahmens (7) während der Befestigung an dem Sitz (3) auf einer Vorderseite des Gasgenerators (6) in einer Vorne-Hinten-Richtung des Fahrzeugs zu beinhalten, wobei der überlappende Abschnitt (S) geformt ist, um auf dem gefalteten Abschnitt (X1) in einem aufgerollten Zustand oder kollabiert in einem balgartigen Zustand überlappend zu liegen, um eine Unterseite, die breiter als eine Oberseite in einer Auf-Ab-Richtung ist, aufzuweisen, wobei der gefaltete Abschnitt (X1) gefaltet ist, um zwischen dem Sitzrahmen (7) und dem überlappenden Abschnitt (S) in der Fahrzeug-Breitenrichtung angeordnet zu sein.

2. Der Fahrzeugsitz nach Anspruch 1, wobei der gefaltete Abschnitt (X1) so konfiguriert ist, dass er den überlappenden Abschnitt (S) hin zu der Fahrzeugkomponente in der Fahrzeug-Breitenrichtung bei Aufnahme einer Reaktionskraft von dem Sitzrahmen (7) während des Auslösens und Aufblasens des Seitenairbags (2) herausdrücken kann.
3. Ein Fahrzeugsitz (3) umfassend einen Sitzrahmen (7) und eine Fahrzeug-Seitenairbagvorrichtung (1), umfassend:

einen Seitenairbag (2), der im Inneren eines Fahrzeugsitzes (3) bereitgestellt ist und von dem Sitz (3) aus zwischen einem Insassen (P) und einer Fahrzeugkomponente, die seitlich zu dem Insassen (P) in einer Fahrzeug-Breitenrichtung positioniert ist, ausgelöst und aufgeblasen werden kann; und

einen Gasgenerator (6), der an einem Sitzrahmen (7) des Sitzes (3) befestigt ist und bewirkt, dass Gasgeneratorgas in den Seitenairbag (2) eingeführt wird,

wobei der Gasgenerator (6) im Inneren des Seitenairbags (2) nahe einem hinteren Ende in Aus-

- lösungs- und Aufblasrichtung verstaute ist, in einem ausgebreiteten Zustand weist der Seitenairbag (2) einen Oberteil (2e) und einen Unterteil (2d) auf, der auf dem Oberteil (2e) zu falten und zu platzieren ist, wobei der Unterteil (2d) schräg nach unten zu der Vorderseite in der Vorne-Hinten-Richtung des Fahrzeugs ausgebildet ist, und nachdem der Unterteil (2d) gefaltet und auf dem Oberteil (2e) platziert worden ist, weist der Seitenairbag einen gefalteten Abschnitt (X1) mit einer Faltnie (F1) und einen überlappenden Abschnitt (S) in Reihe aufeinanderfolgend von einer Seite des Gasgenerators (6) zu einem vorderen Ende davon in der Auslösungs- und Aufblasrichtung in einem verstaute Zustand vor der Auslösung auf, wobei der gefaltete Abschnitt (X1) geformt ist, um einen Anlageabschnitt (Q) in Anlage an einer Stützfläche (7a) des Sitzrahmens (7) während der Befestigung an dem Sitz (3) auf einer Vorderseite des Gasgenerators (6) in einer Vorne-Hinten-Richtung des Fahrzeugs zu beinhalten, wobei der überlappende Abschnitt (S) geformt ist, um auf dem gefalteten Abschnitt (X1) in einem aufgerollten Zustand oder kollabiert in einem balgartigen Zustand überlappend zu liegen, um eine Oberseite, die breiter als eine Unterseite in einer Auf-Ab-Richtung ist, aufzuweisen, wobei der gefaltete Abschnitt (X1) gefaltet ist, um zwischen dem Sitzrahmen (7) und dem überlappenden Abschnitt (S) in der Fahrzeug-Breitenrichtung angeordnet zu sein.
4. Der Fahrzeugsitz nach Anspruch 3, wobei der gefaltete Abschnitt (X1) so konfiguriert ist, dass er den überlappenden Abschnitt (S) hin zu der Fahrzeugkomponente in der Fahrzeug-Breitenrichtung bei Aufnahme einer Reaktionskraft von dem Sitzrahmen (7) während des Auslösens und Aufblasens des Seitenairbags (2) herausdrücken kann.
 5. Der Fahrzeugsitz nach einem der Ansprüche 1 bis 4, wobei die Fahrzeugkomponente eine Fahrzeugtür ist.
 6. Der Sitz nach einem der Ansprüche 1 bis 4, wobei die Fahrzeugkomponente ein Konsolenkasten ist, der auf einer Zentrumsseite in dem Fahrzeug in der Fahrzeug-Breitenrichtung bereitgestellt ist.
 7. Der Fahrzeugsitz nach einem der Ansprüche 1 bis 6, wobei der Seitenairbag (2) gefaltet ist, um einen Oberteil (2c) in der Auf-Ab-Richtung aufzuweisen, der auf einem Unterteil (2b) platziert wird, bevor der gefaltete Abschnitt (X1) und der überlappende Abschnitt (S) ausgebildet werden.
 8. Der Fahrzeugsitz nach einem der Ansprüche 1 bis

7, wobei, in einem ausgebreiteten Zustand, der Seitenairbag (2) einen zusätzlichen gefalteten Abschnitt (X2) mit einer zusätzlichen Faltnie (F2) zwischen dem gefalteten Abschnitt (X1) und dem überlappenden Abschnitt (S) aufweist, und, in einem verstaute Zustand vor der Auslösung, der zusätzliche gefaltete Abschnitt (X2) geformt ist, um mindestens einmal entlang der zusätzlichen Faltnie (F2) zu der Fahrzeug-Hinterseite von der Fahrzeug-Vorderseite oder umgekehrt in einer Anordnung parallel zu dem gefalteten Abschnitt (F1) zurückgefaltet zu werden, und der überlappende Abschnitt (S) zwischen dem zusätzlichen gefalteten Abschnitt (X2) und dem gefalteten Abschnitt (X1) in der Fahrzeugbreitenrichtung angeordnet ist.

Revendications

1. Un siège de véhicule (3) comprenant une armature de siège (7) et un dispositif de coussin de sécurité gonflable latéral de véhicule (1), comprenant :
 - un coussin de sécurité gonflable latéral (2) fourni à l'intérieur d'un siège de véhicule (3) et pouvant être déployé et gonflé à partir du siège (3) vers l'espace entre un occupant (P) et un composant de véhicule positionné latéralement par rapport à l'occupant (P) dans une direction de largeur du véhicule ; et
 - un gonfleur (6) relié à une armature de siège (7) du siège (3) et provoquant l'introduction d'un gaz de gonfleur dans le coussin de sécurité gonflable latéral (2),
 - le gonfleur (6) étant stocké dans le coussin de sécurité gonflable latéral (2) à proximité d'une extrémité arrière de celui-ci dans une direction de déploiement et de gonflage,
 - le coussin de sécurité gonflable latéral (2) ayant une partie inférieure (2b) et une partie supérieure (2c) destinée à être pliée et placée sur la partie inférieure (2b) dans un état déployé, la partie supérieure (2c) étant formée de façon oblique vers le haut, vers le côté frontal dans la direction avant-arrière du véhicule, et
 - après que la partie supérieure (2c) a été pliée et placée sur la partie inférieure (2b), le coussin de sécurité gonflable latéral ayant une partie pliée (X1) avec une ligne de pliage (F1) et une partie superposée (S) l'une après l'autre, de façon séquentielle, d'un côté du gonfleur (6) à une extrémité frontale de celui-ci dans la direction de déploiement et de gonflage, dans un état stocké avant déploiement, la partie pliée (X1) étant formée pour comprendre une partie de butée (Q) contiguë à une surface de support (7a) de l'armature de siège (7) pendant la liaison au siège (3) sur un côté frontal du gonfleur (6) dans

- une direction avant-arrière du véhicule, la partie superposée (S) étant formée pour être superposée à la partie pliée (X1) dans un état roulé ou rabattu dans un état de type soufflet, de sorte à avoir un côté inférieur plus large qu'un côté supérieur dans une direction haut-bas, la partie pliée (X1) étant pliée pour être disposée entre l'armature de siège (7) et la partie superposée (S) dans la direction de la largeur du véhicule.
2. Le siège de véhicule selon la revendication 1, la partie pliée (X1) étant configurée pour être capable de pousser la partie superposée (S) vers le composant de véhicule dans la direction de la largeur du véhicule à la réception d'une force de réaction de l'armature de siège (7) pendant le déploiement et le gonflage du coussin de sécurité gonflable latéral (2).
3. Un siège de véhicule (3) comprenant une armature de siège (7) et un dispositif de coussin de sécurité gonflable latéral de véhicule (1), comprenant :
- un coussin de sécurité gonflable latéral (2) fourni à l'intérieur d'un siège de véhicule (3) et pouvant être déployé et gonflé à partir du siège (3) vers l'espace entre un occupant (P) et un composant de véhicule positionné latéralement par rapport à l'occupant (P) dans une direction de largeur du véhicule ; et
- un gonfleur (6) relié à une armature de siège (7) du siège (3) et provoquant l'introduction d'un gaz de gonfleur dans le coussin de sécurité gonflable latéral (2),
- le gonfleur (6) étant stocké dans le coussin de sécurité gonflable latéral (2) à proximité d'une extrémité arrière de celui-ci dans une direction de déploiement et de gonflage,
- le coussin de sécurité gonflable latéral (2) ayant une partie supérieure (2e) et une partie inférieure (2d) destinée à être pliée et placée sur la partie supérieure (2e) dans un état déployé, la partie inférieure (2d) étant formée de façon oblique vers le bas, vers le côté frontal dans la direction avant-arrière du véhicule, et, après que la partie inférieure (2d) a été pliée et placée sur la partie supérieure (2e), le coussin de sécurité gonflable latéral ayant une partie pliée (X1) avec une ligne de pliage (F1) et une partie superposée (S) l'une après l'autre, de façon séquentielle, d'un côté du gonfleur (6) à une extrémité frontale de celui-ci dans la direction de déploiement et de gonflage, dans un état stocké avant déploiement, la partie pliée (X1) étant formée pour comprendre une partie de butée (Q) contiguë à une surface support (7a) de l'armature de siège (7) pendant la liaison au siège (3) sur un côté frontal du gonfleur (6) dans une direction avant-arrière du véhicule, la partie superposée (S) étant formée pour être superposée à la partie pliée (X1) dans un état roulé ou rabattu dans un état de type soufflet, de sorte à avoir un côté supérieur plus large qu'un côté inférieur dans une direction haut-bas,
- la partie pliée (X1) étant pliée pour être disposée entre l'armature de siège (7) et la partie superposée (S) dans la direction de la largeur du véhicule.
4. Le siège de véhicule selon la revendication 3, la partie pliée (X1) étant configurée pour être capable de pousser la partie superposée (S) vers le composant de véhicule dans la direction de la largeur du véhicule à la réception d'une force de réaction de l'armature de siège (7) pendant le déploiement et le gonflage du coussin de sécurité gonflable latéral (2).
5. Le siège de véhicule selon l'une quelconque des revendications 1 à 4, le composant de véhicule étant une portière de véhicule.
6. Le siège de véhicule selon l'une quelconque des revendications 1 à 4, le composant de véhicule étant une boîte console fournie sur un côté central dans le véhicule, dans la direction de la largeur du véhicule.
7. Le siège de véhicule selon l'une quelconque des revendications 1 à 6, le coussin de sécurité gonflable latéral (2) étant plié pour avoir une partie supérieure (2c) dans la direction haut-bas placée sur une partie inférieure (2b) avant que la partie pliée (X1) et la partie superposée (S) soient formées.
8. Le siège de véhicule selon l'une quelconque des revendications 1 à 7, le coussin de sécurité gonflable latéral (2) ayant une partie pliée supplémentaire (X2) avec une ligne de pliage supplémentaire (F2) entre la partie pliée (X1) et la partie superposée (S) dans un état déployé, la partie pliée supplémentaire (X2) étant formée pour être repliée au au moins une fois le long de la ligne de pliage supplémentaire (F2) vers le côté arrière du véhicule à partir du côté avant du véhicule ou, inversement, dans une disposition parallèle à la partie pliée (F1), dans un état stocké avant déploiement, et la partie superposée (S) étant disposée entre la partie pliée supplémentaire (X2) et la partie pliée (X1) dans la direction de la largeur du véhicule.

FIG. 1

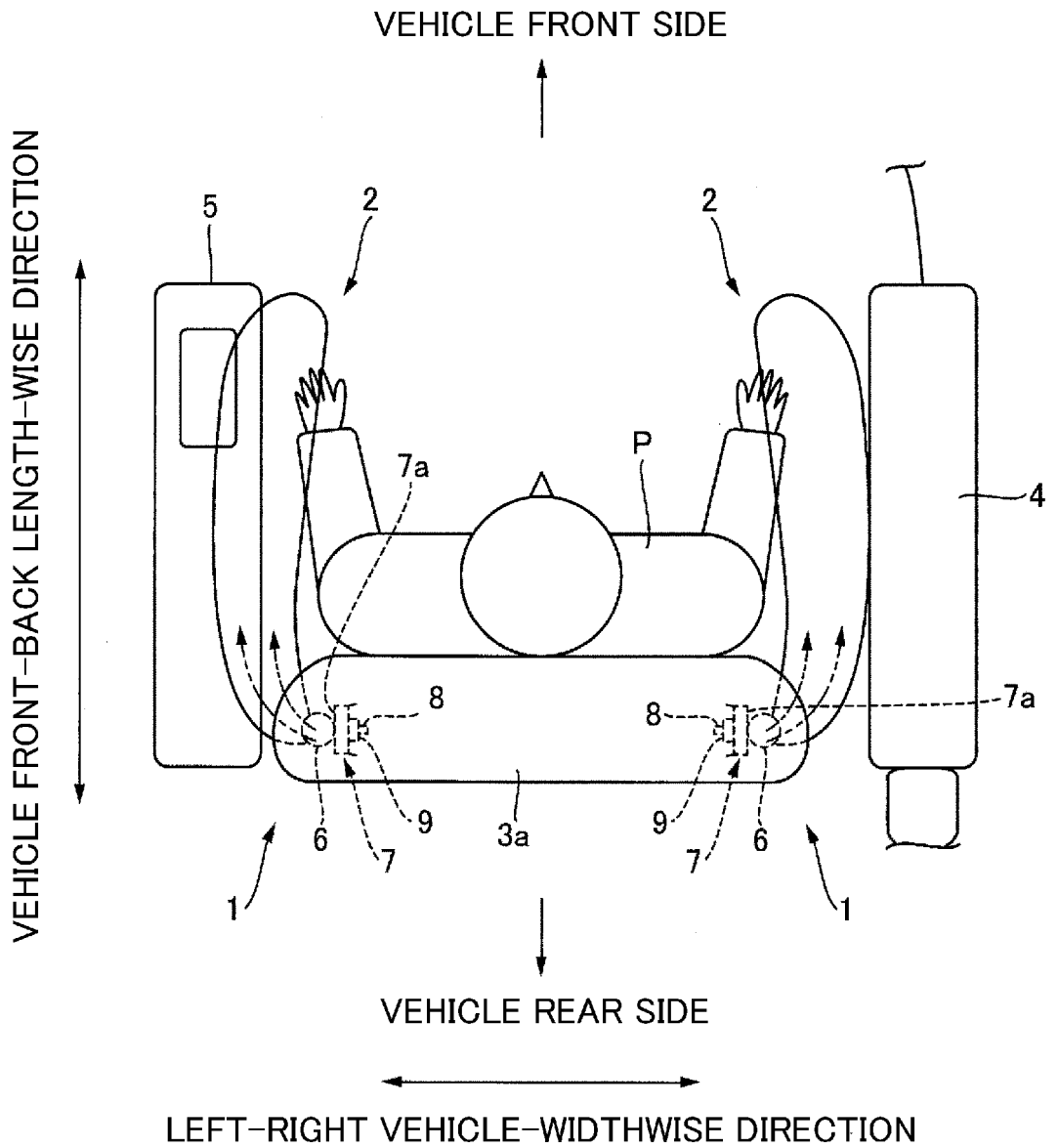

FIG. 2

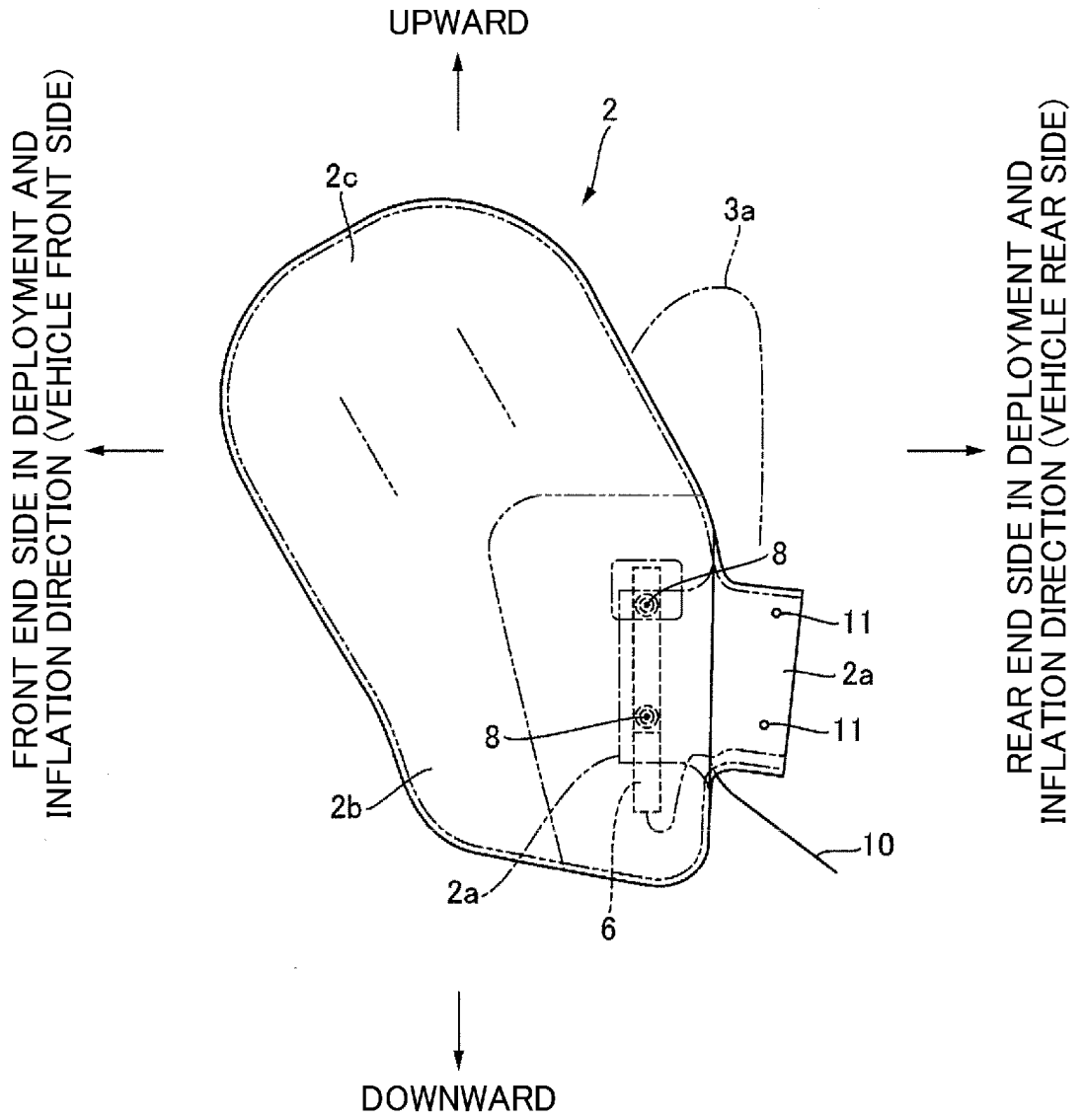

FIG. 3

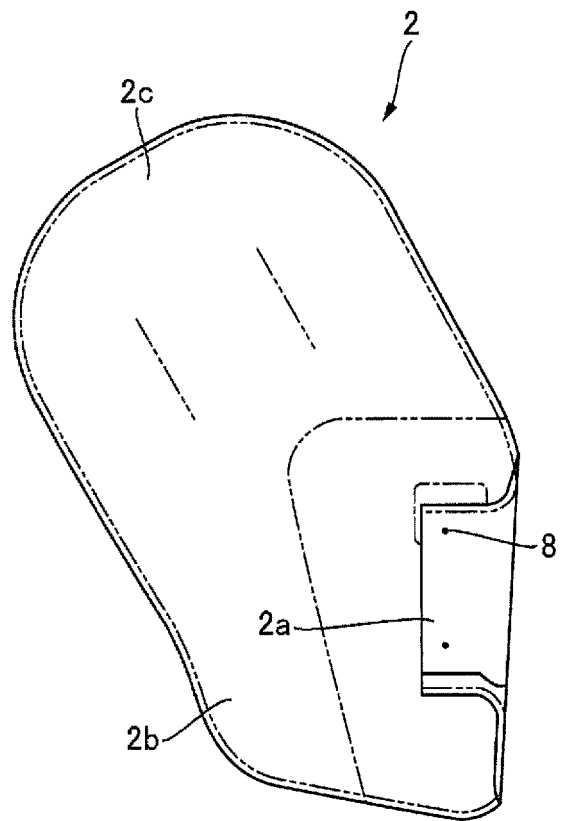

FIG. 4

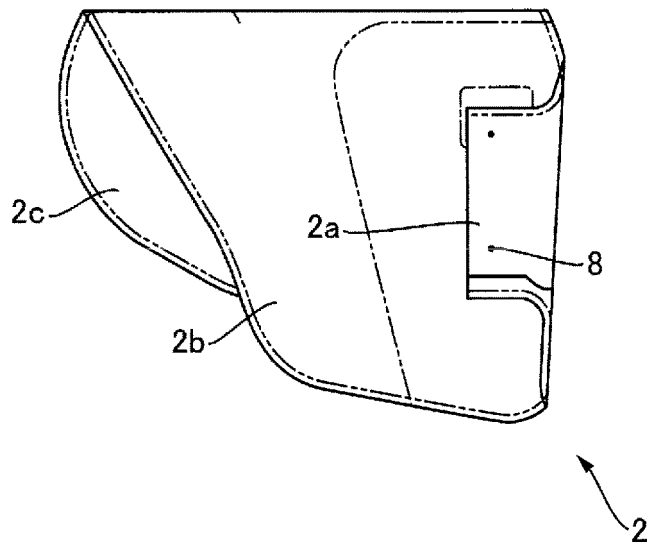

FIG. 5

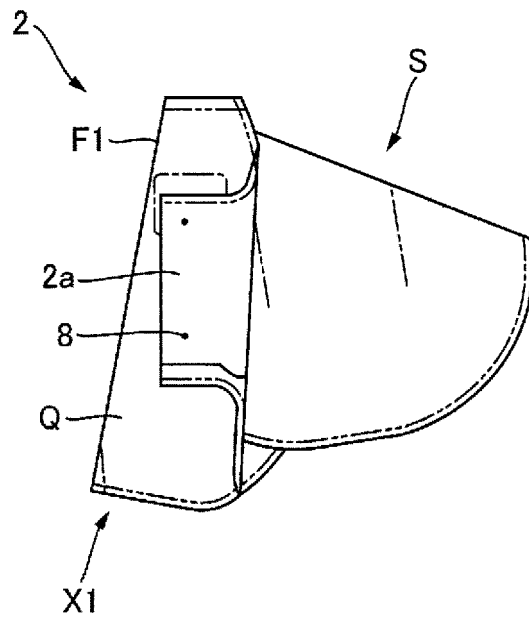

FIG. 6

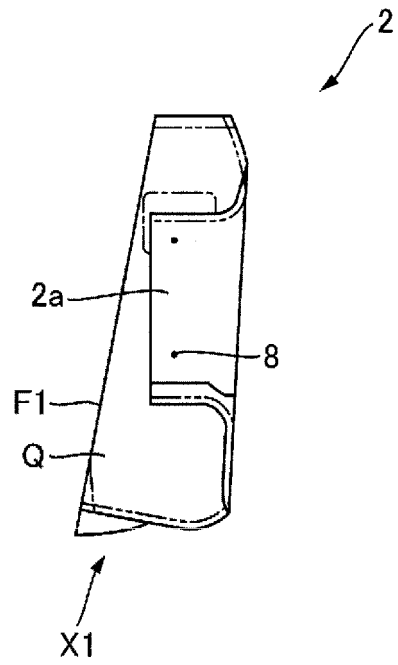

FIG. 7

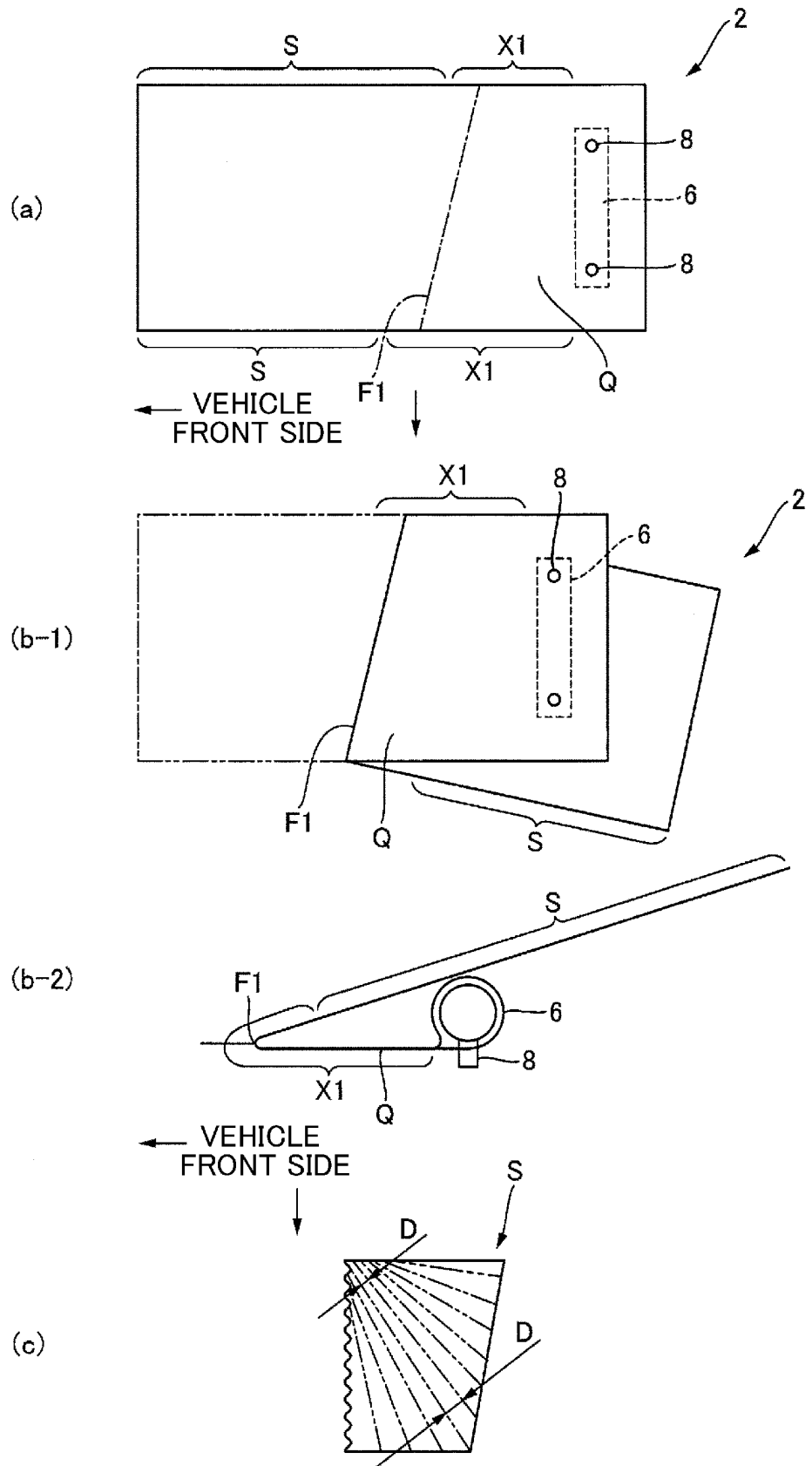

FIG. 8

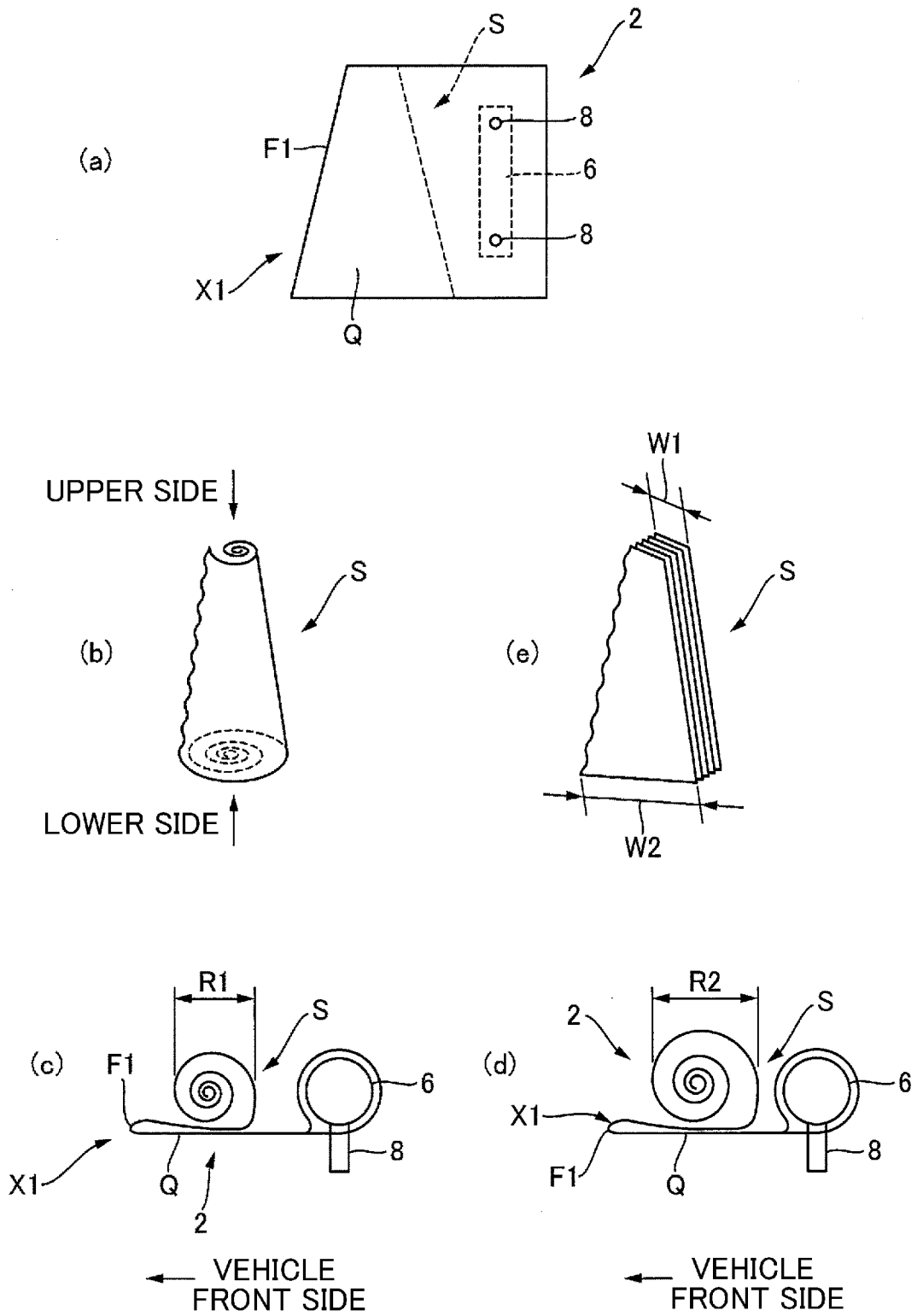

FIG. 9

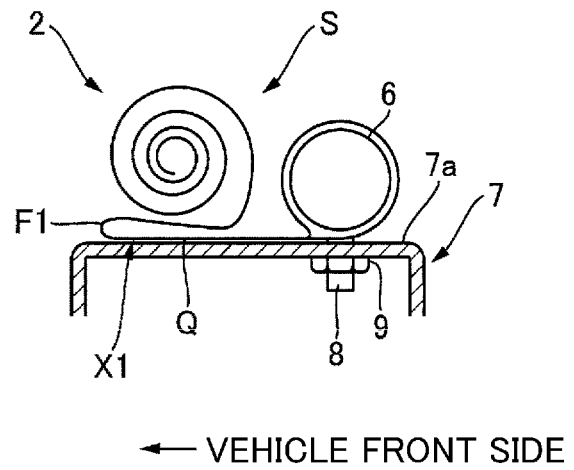

FIG. 10

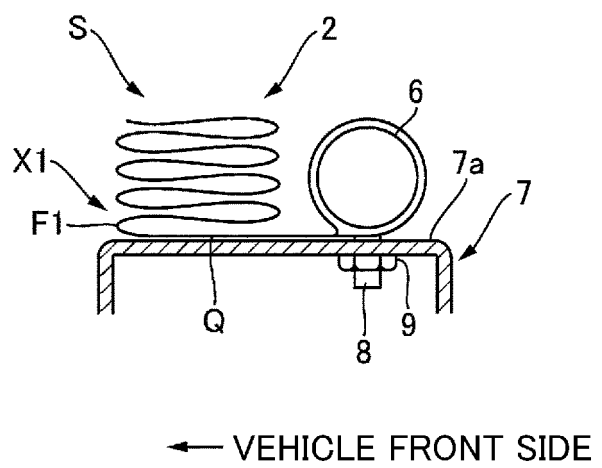

FIG. 11

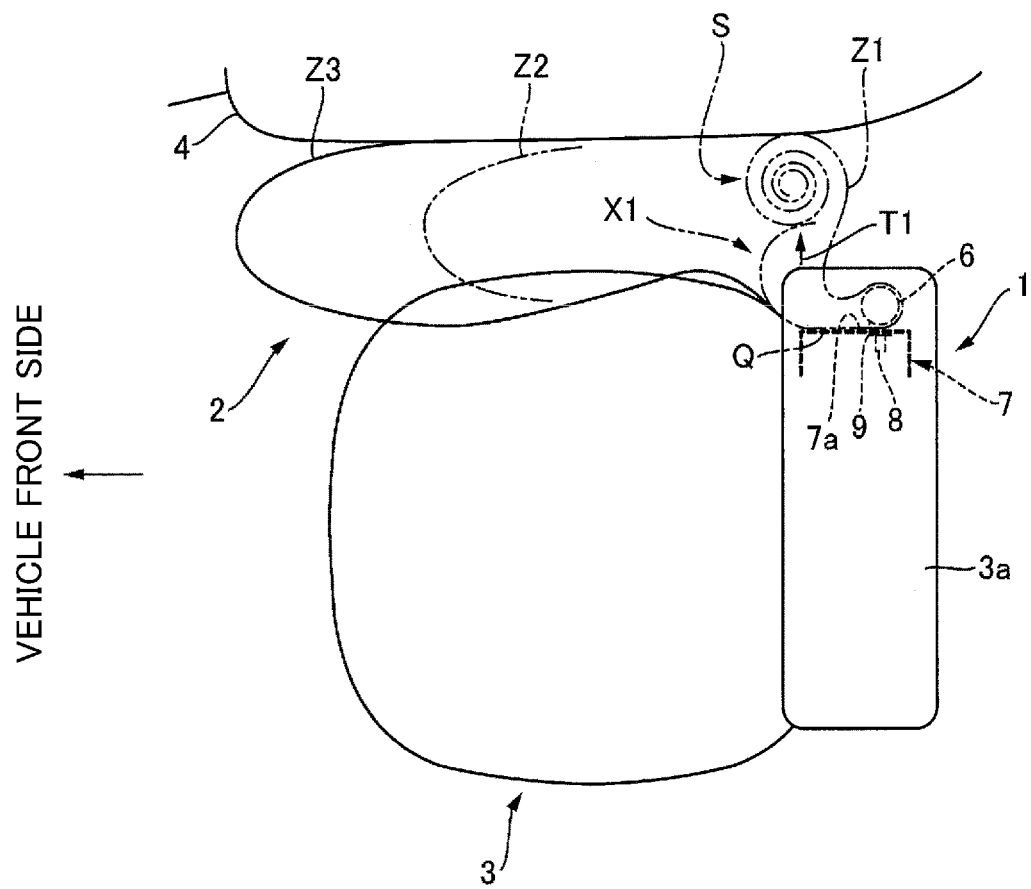

FIG. 12

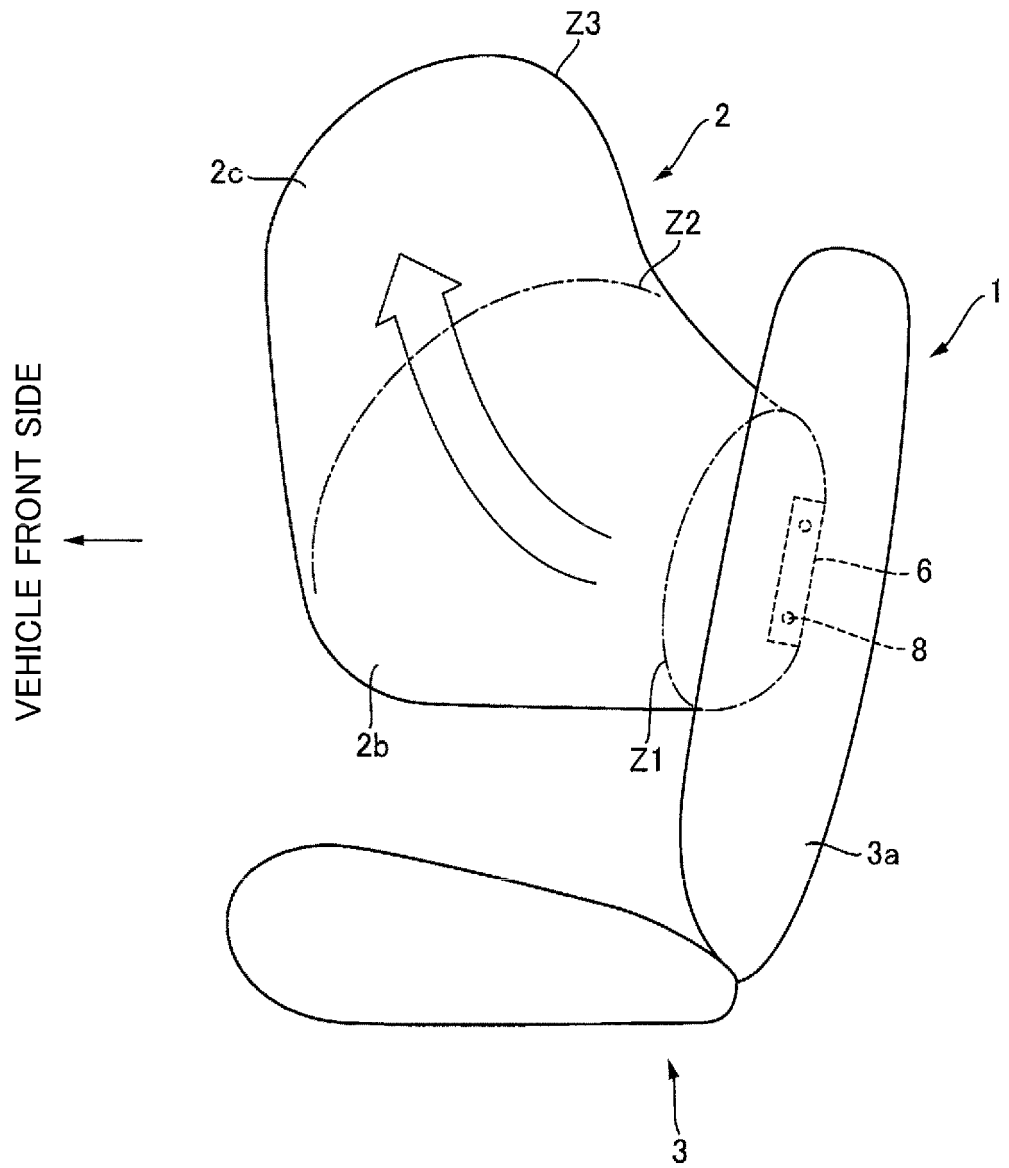

FIG. 13

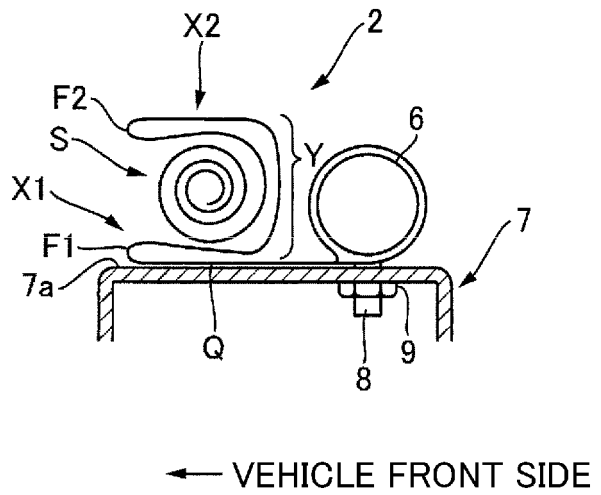

FIG. 14

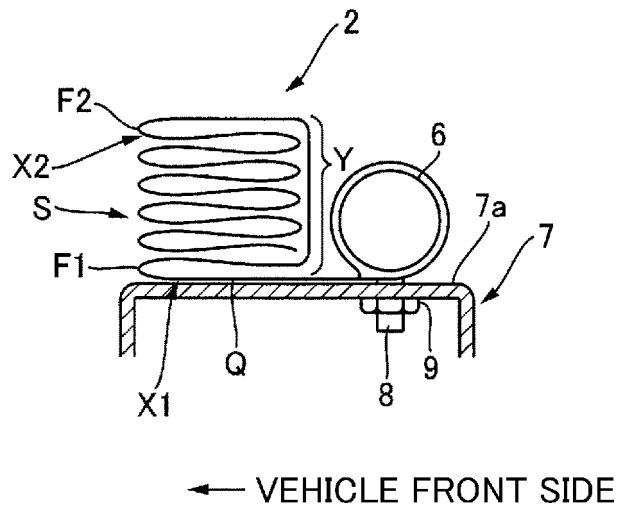

FIG. 15

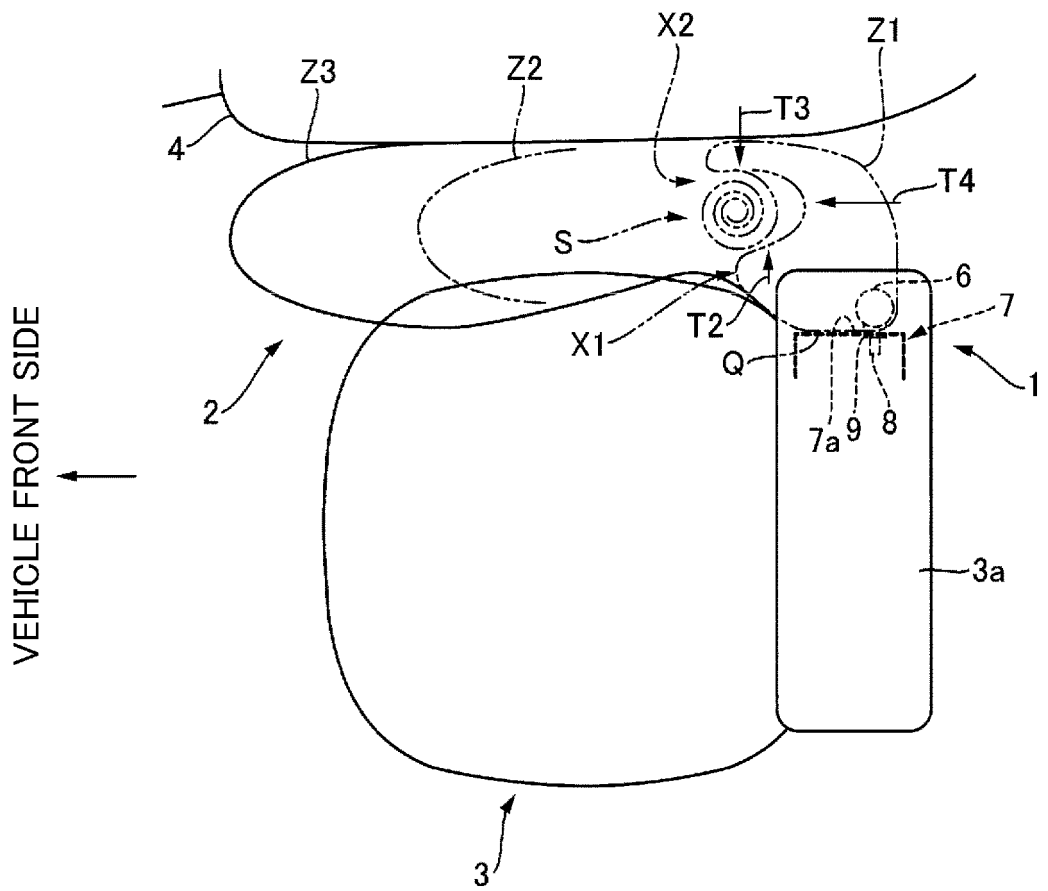

FIG. 16

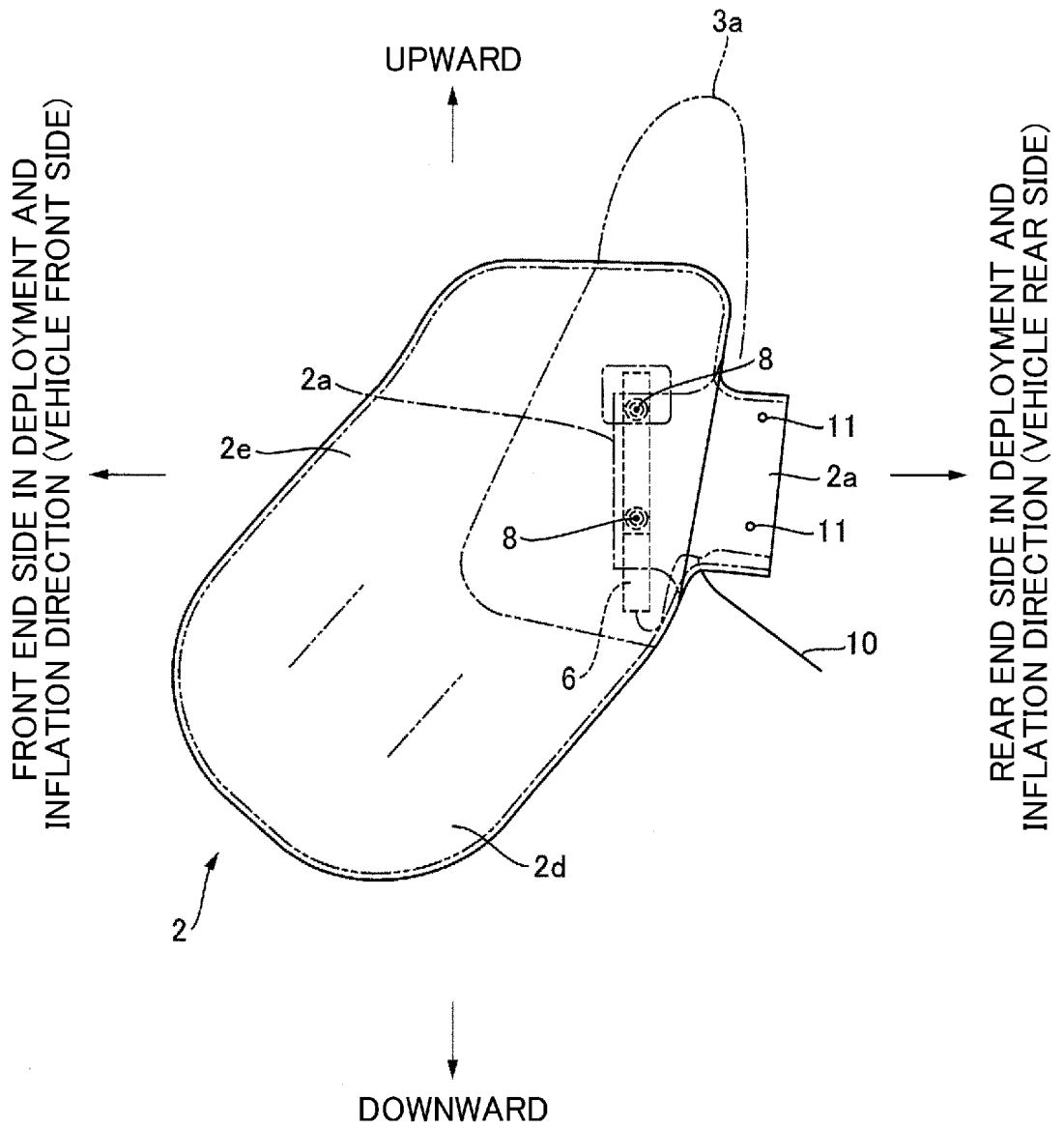

FIG. 17

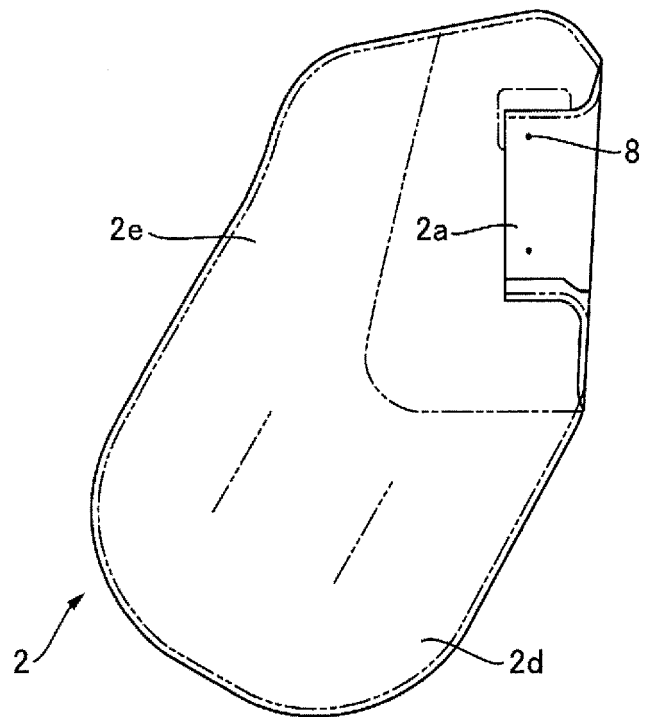

FIG. 18

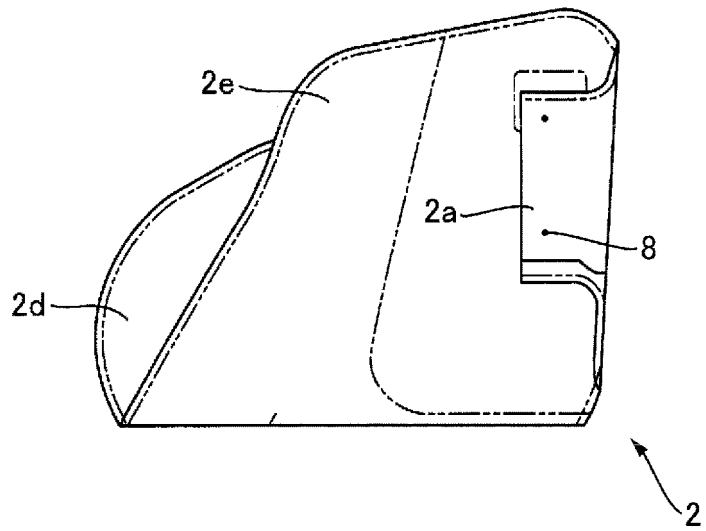

FIG. 19

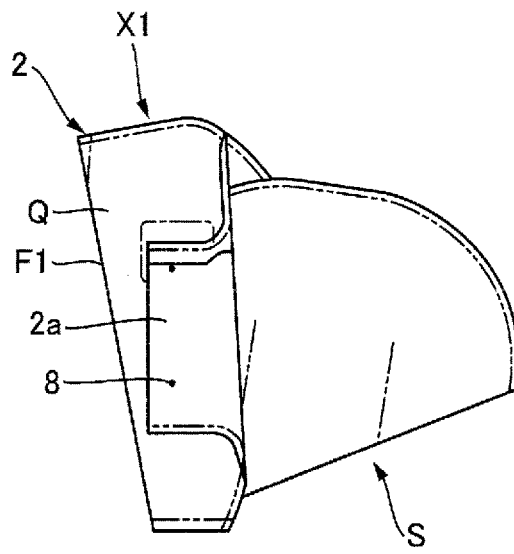

FIG. 20

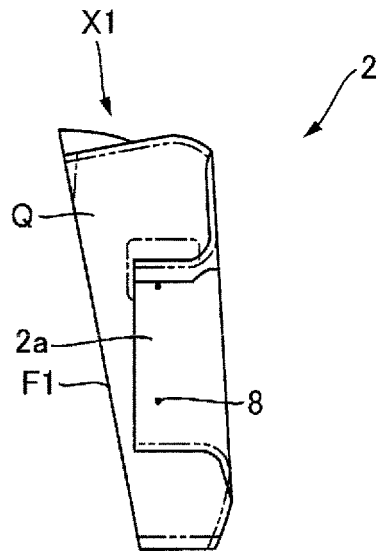
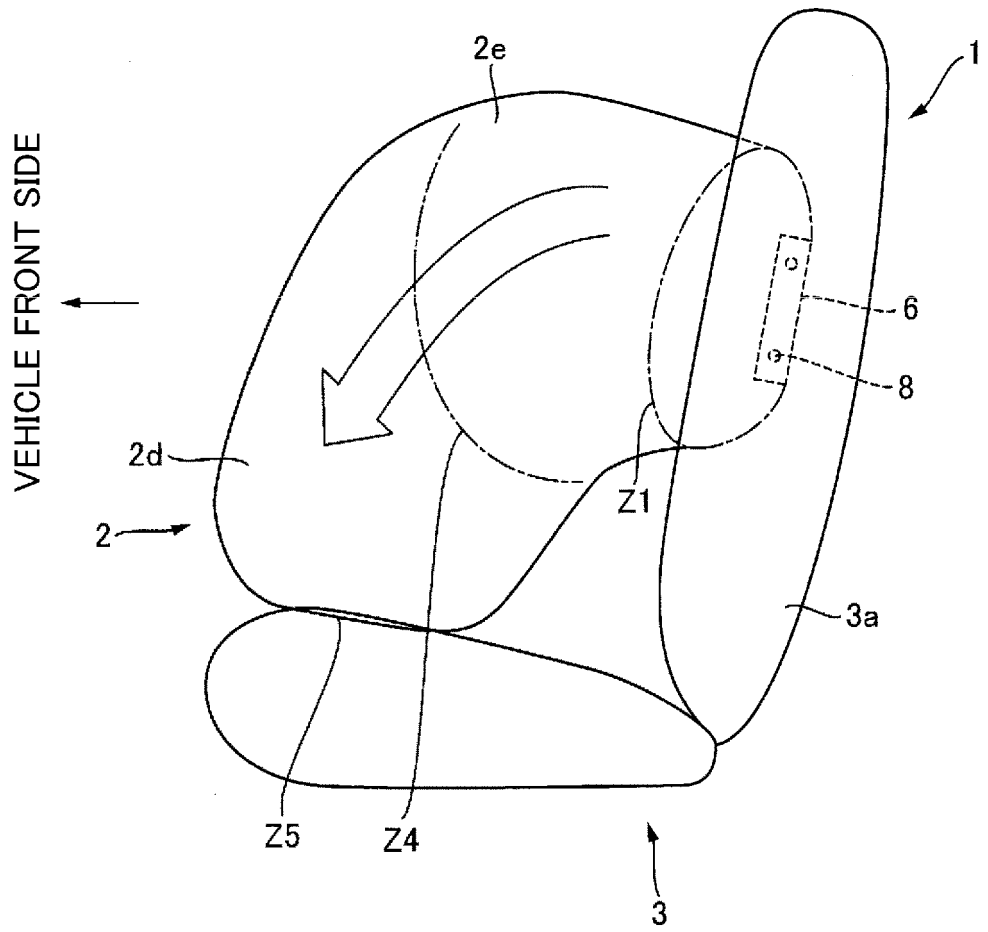

FIG. 21



REFERENCES CITED IN THE DESCRIPTION

This list of references cited by the applicant is for the reader's convenience only. It does not form part of the European patent document. Even though great care has been taken in compiling the references, errors or omissions cannot be excluded and the EPO disclaims all liability in this regard.

Patent documents cited in the description

- JP H8142790 B [0006]
- JP H11152004 B [0006]
- JP H11180243 B [0006]
- JP 20011711468 B [0006]