



US005528250A

United States Patent [19]

[11] **Patent Number:** 5,528,250

Sherwood et al.

[45] **Date of Patent:** * Jun. 18, 1996

[54] DEPLOYABLE SATELLITE ANTENNA FOR USE ON VEHICLES

FOREIGN PATENT DOCUMENTS

[75] Inventors: **William J. Sherwood**, West Burlington; **Charles E. Rodeffer**; **Mark A. Rodeffer**, both of Burlington, all of Iowa

60-233905 11/1985 Japan .
60-260205 12/1985 Japan .
60-260207 12/1985 Japan .

[73] Assignee: **Winegard Company**, Burlington, Iowa

Primary Examiner—Donald T. Hajec

Assistant Examiner—Tan Ho

[*] Notice: The term of this patent shall not extend beyond the expiration date of Pat. No. 5,337,062.

Attorney, Agent, or Firm—Dorr, Carson, Sloan & Birney

[21] Appl. No.: 400,333

[57] ABSTRACT

[22] Filed: **Mar. 7, 1995**

Related U.S. Application Data

[63] Continuation-in-part of Ser. No. 265,392, Jun. 24, 1994, Pat. No. 5,418,542, which is a continuation of Ser. No. 977,907, Nov. 18, 1992, Pat. No. 5,337,062.

[51] Int. Cl.⁶ **H01Q 1/32; H01Q 3/00**

[52] U.S. Cl. **343/711; 343/765; 343/766; 343/882**

[58] Field of Search 343/711-712, 713, 343/714, 878, 880, 881, 882, 840, 763, 765, 766, 915; 248/183

A deployable satellite antenna system permits an antenna with elevation and azimuth control to be mounted to the roof of a vehicle. The elevation control assembly for the antenna system has a base with two parallel tracks and a slider that moves along these tracks. The antenna reflector is connected to a support frame pivotably attached to the slider. Pivot arms are pivotally attached between the reflector and the base adjacent to the parallel tracks. The elevational position of the antenna is adjusted by a motor that controls the position of the slider along the parallel tracks between a stowed position in which the reflector is stowed facing the vehicle and a deployed position in which the reflector is rotated to a maximum elevational angle. In one embodiment, a feed arm supporting the feed horn extends outward from the antenna support frame adjacent to the lower edge of the antenna. The base of the feed arm is pivotably attached to the support frame so that the feed horn is stored beneath the antenna in its stowed position and moves to a predetermined point relative to the antenna in its deployed position. The azimuth of the antenna is controlled by a rotating assembly mounted to the roof of the vehicle beneath the base of the elevation control assembly.

[56] References Cited

U.S. PATENT DOCUMENTS

3,412,404	11/1968	Bergling	343/762
3,587,104	6/1991	Budrow et al.	343/714
3,665,477	5/1972	Budrow et al.	343/714
3,739,387	6/1973	Budrow et al.	343/714
4,309,708	1/1982	Sayovitz	343/713
4,490,726	12/1984	Weir	343/840
4,602,259	7/1986	Shepard	343/882
4,663,633	5/1987	Wilson	343/714
4,710,778	12/1987	Radov	343/882
4,811,026	3/1989	Bissett	343/766
4,868,578	9/1989	Bruinsma et al.	343/882
4,887,091	12/1989	Yamada	343/714
4,937,587	6/1990	Tsuda	343/765
5,337,062	4/1994	Sherwood et al.	343/711

9 Claims, 15 Drawing Sheets

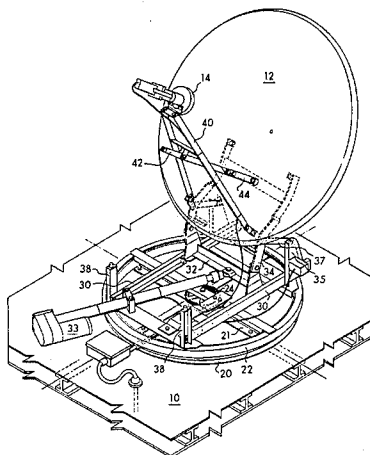

Fig. 1

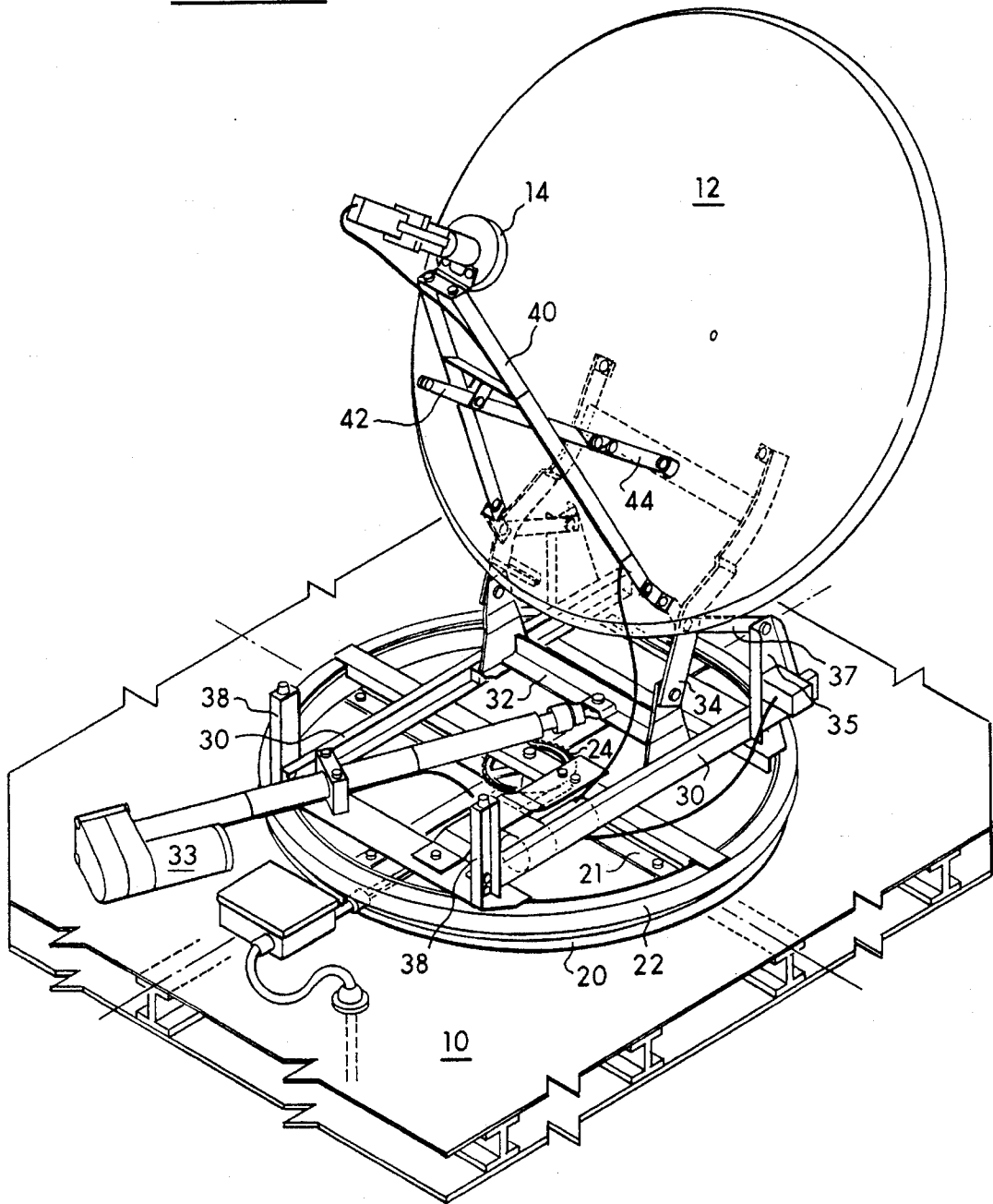

Fig. 2

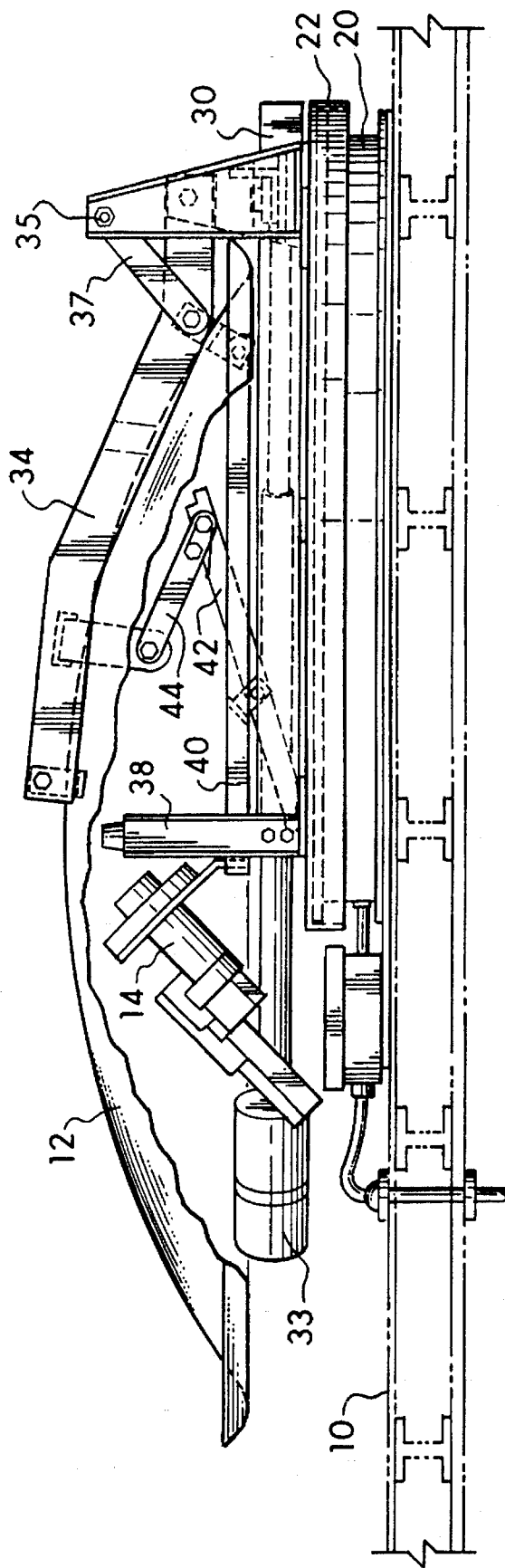

Fig. 3

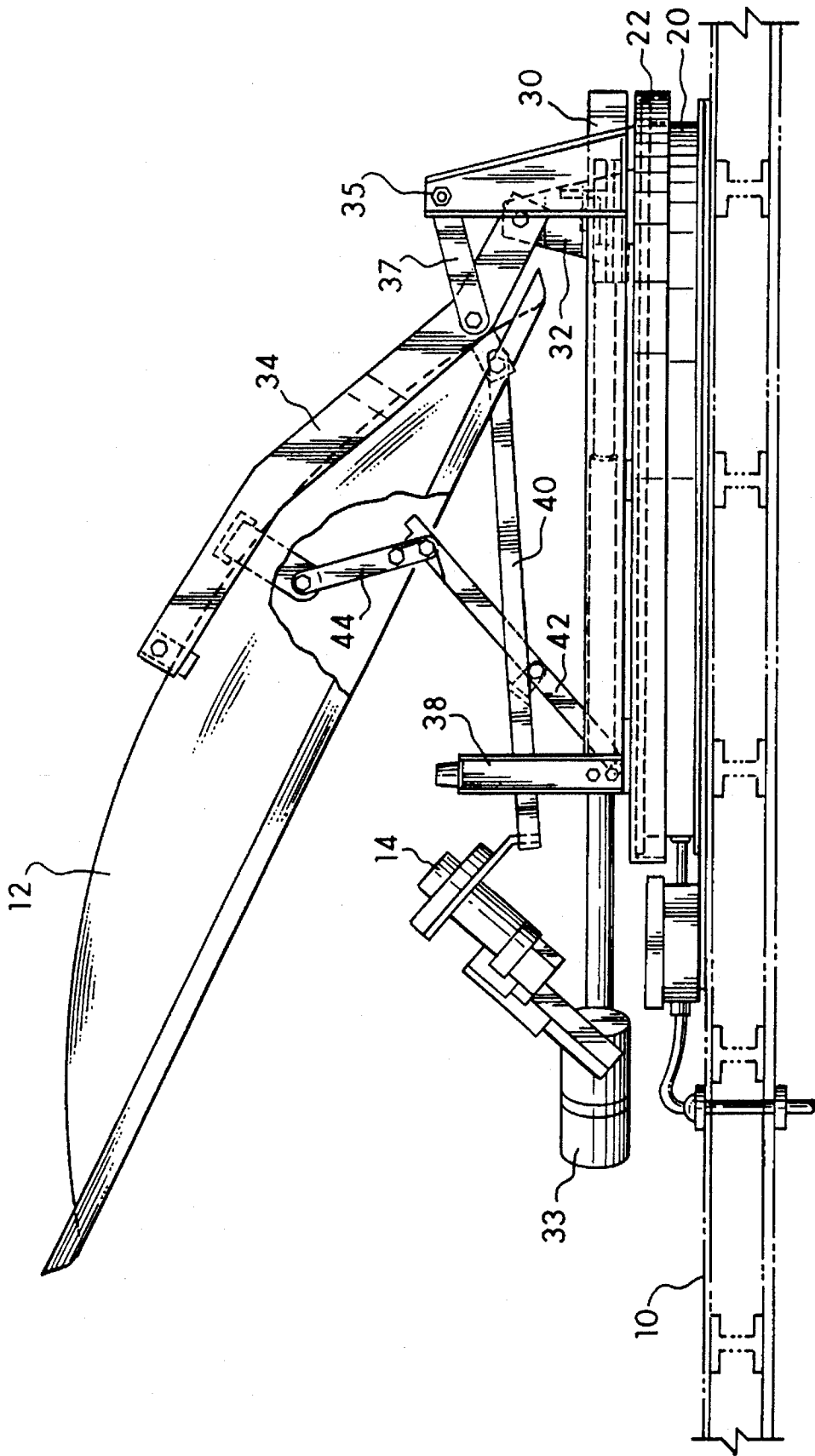
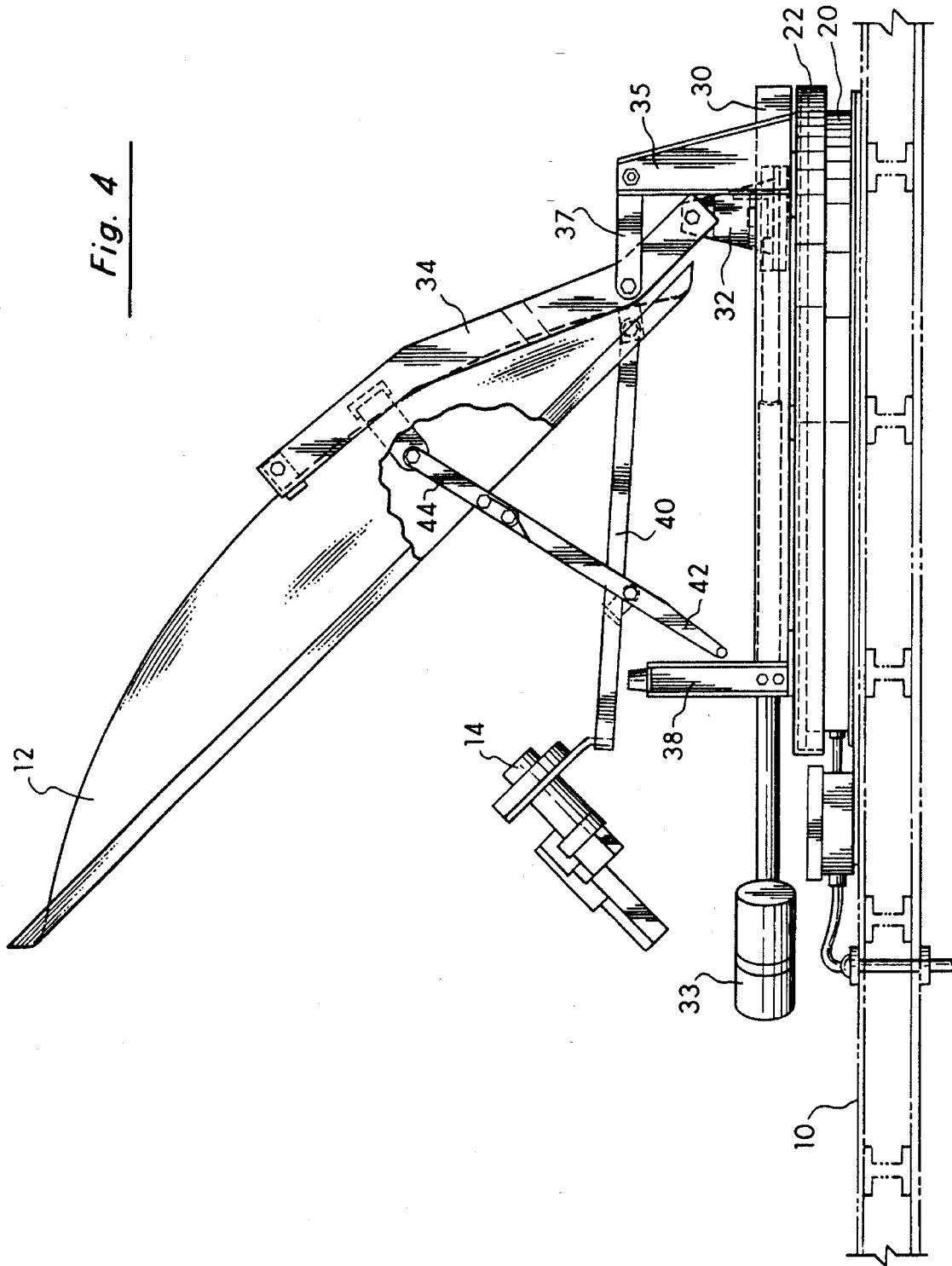

Fig. 4



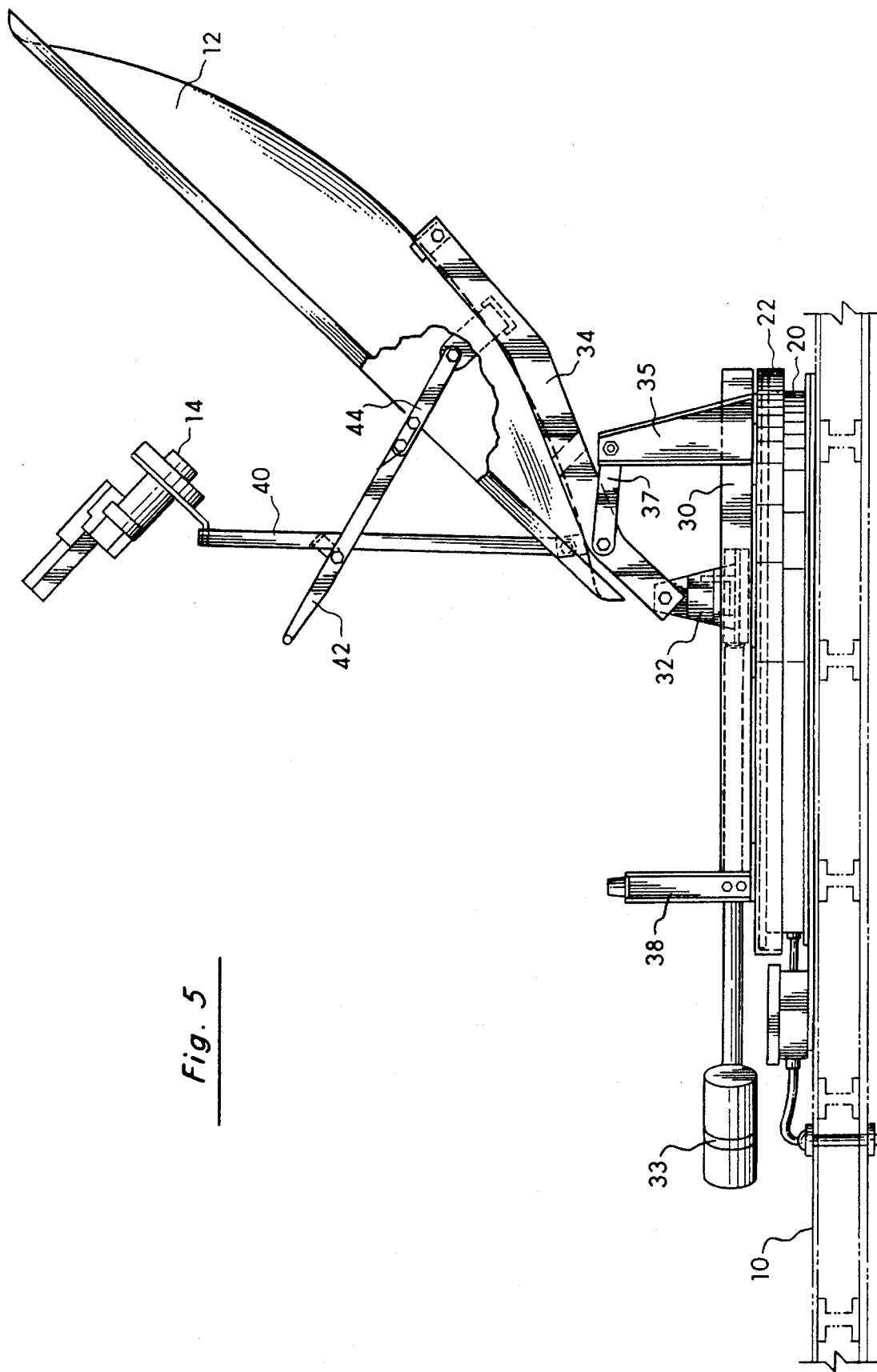

Fig. 5

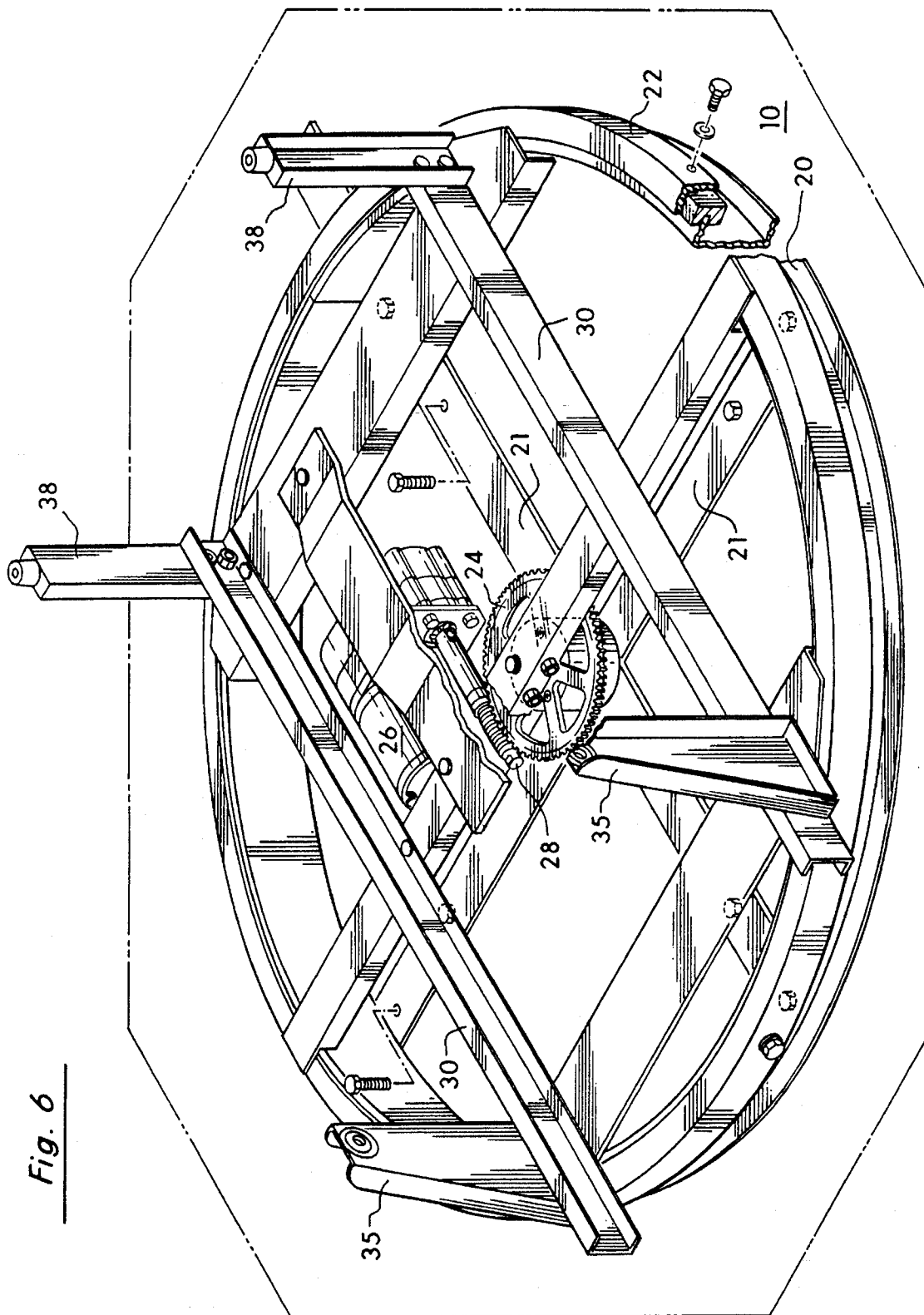
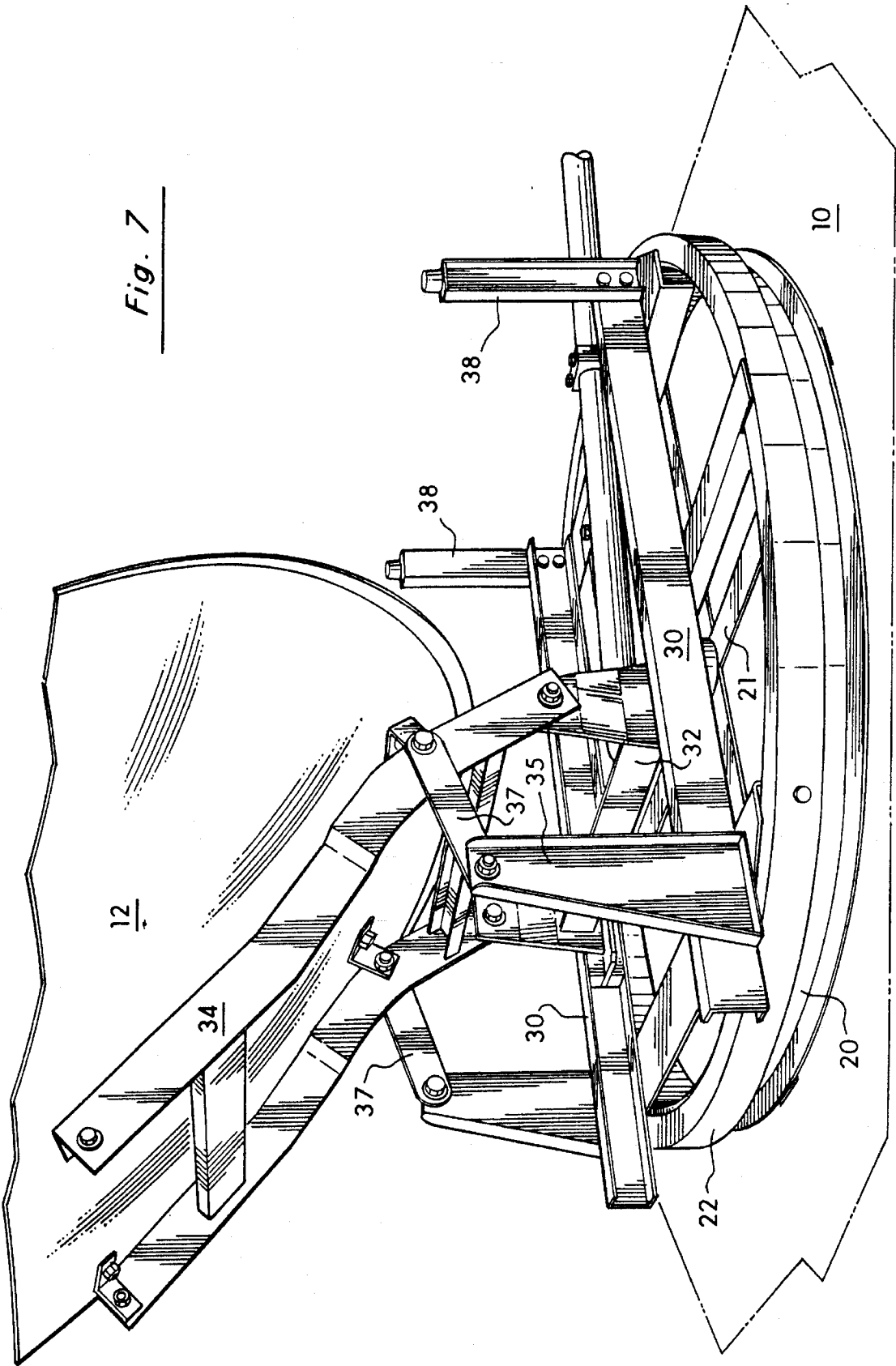
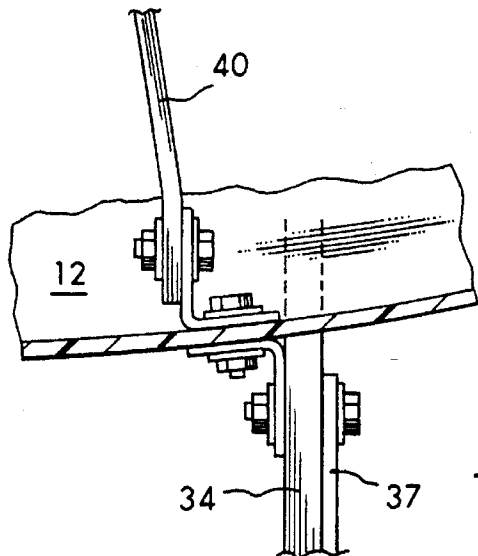
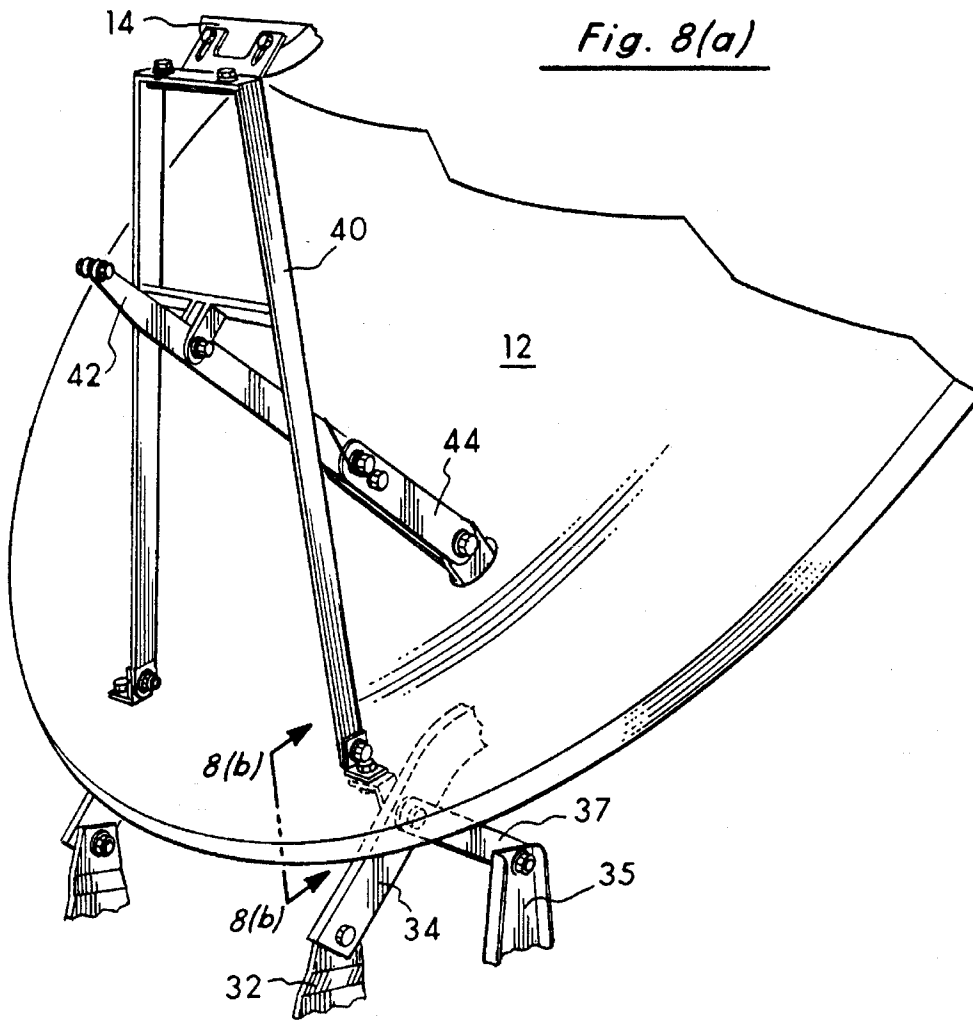

Fig. 6

Fig. 7





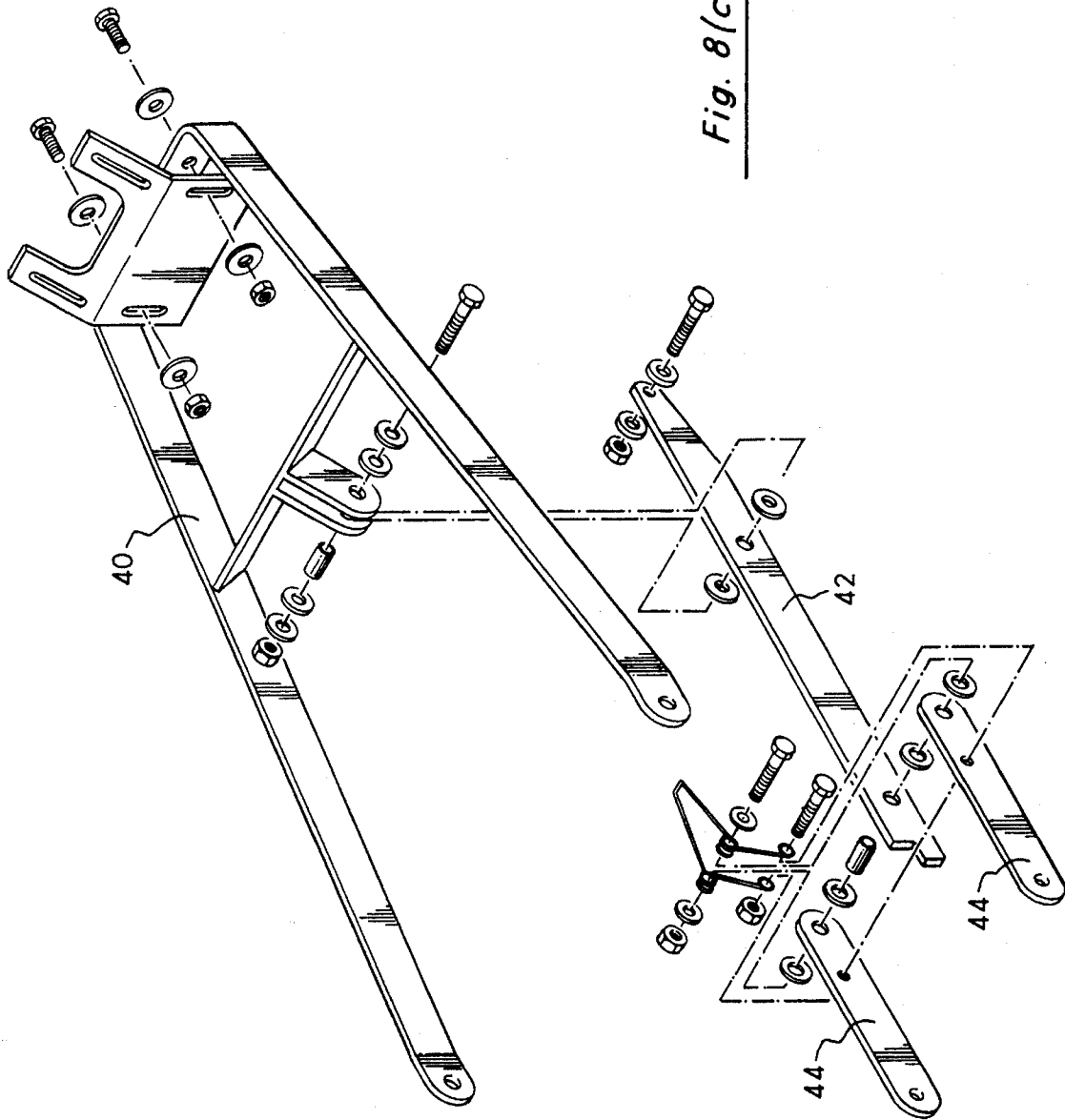

Fig. 8(c)

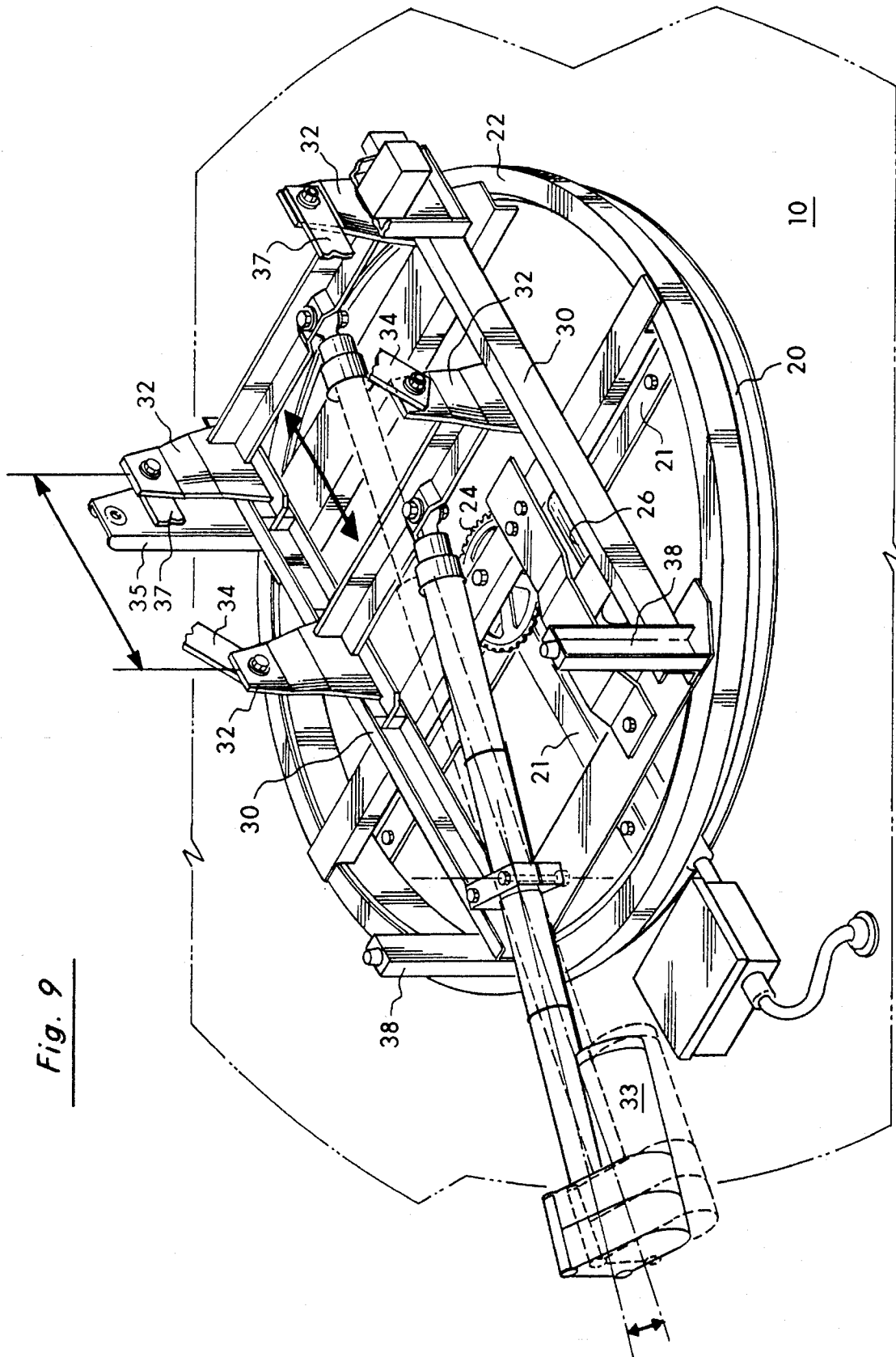
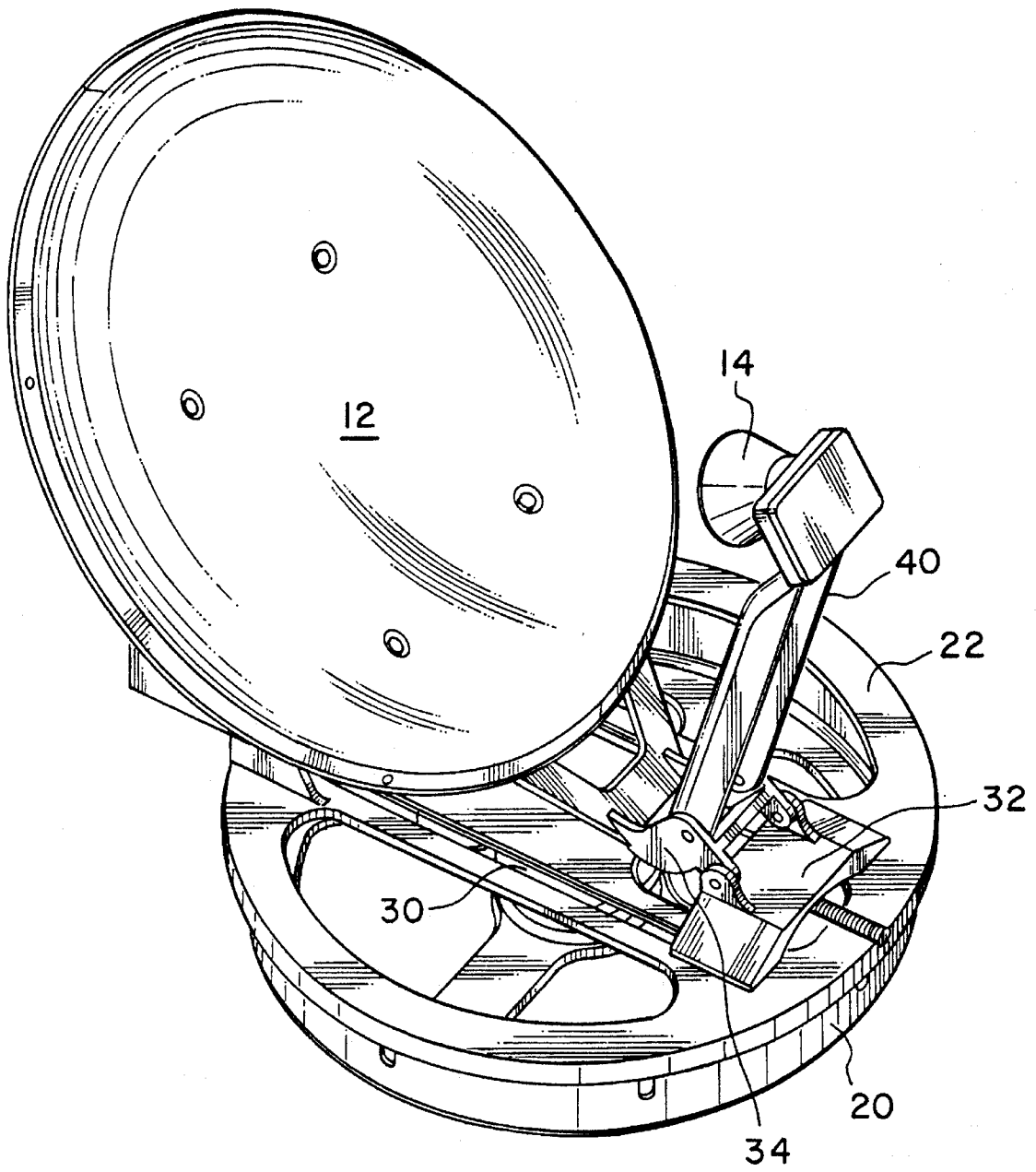

Fig. 9

Fig. 10



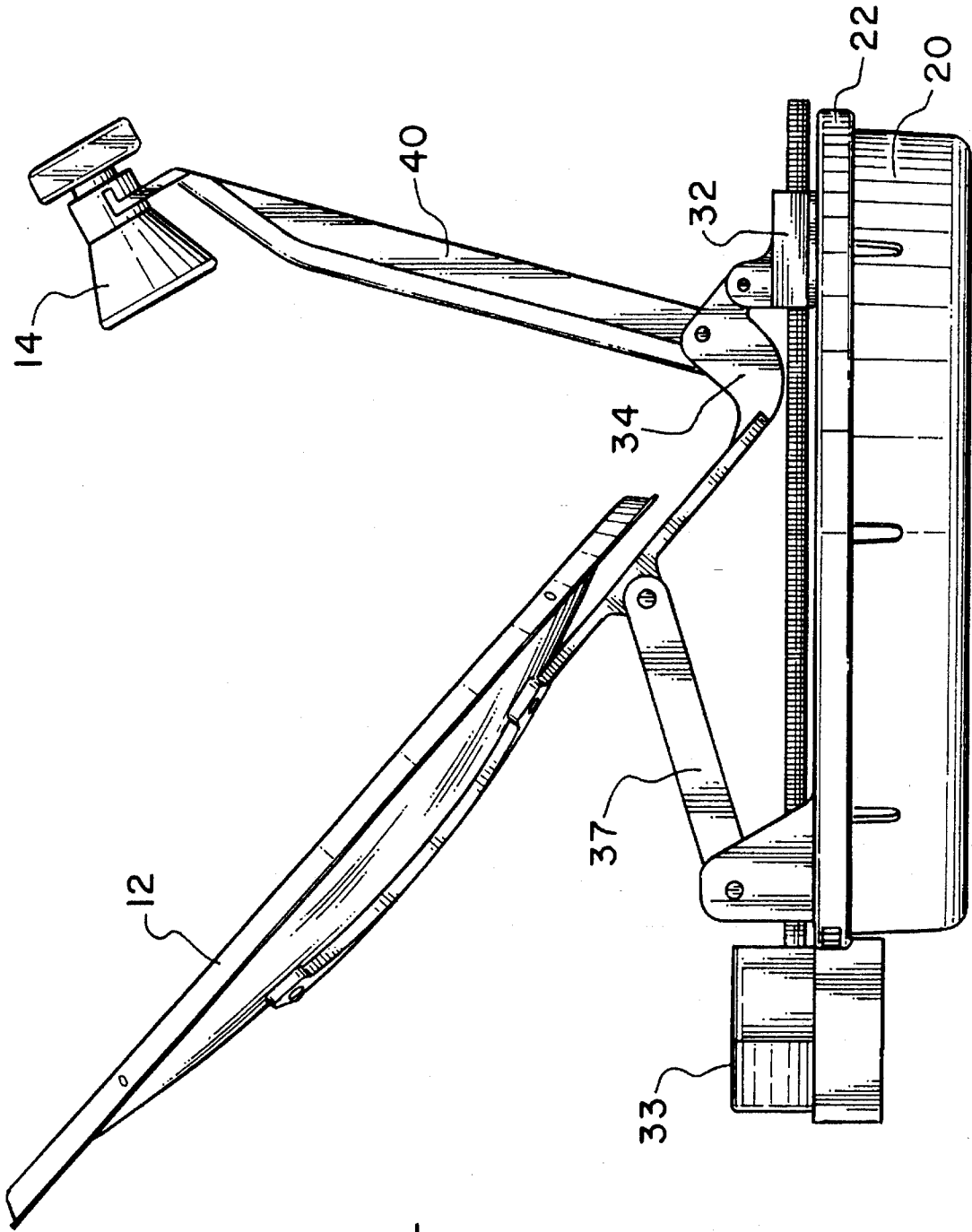

Fig. 11

Fig. 12

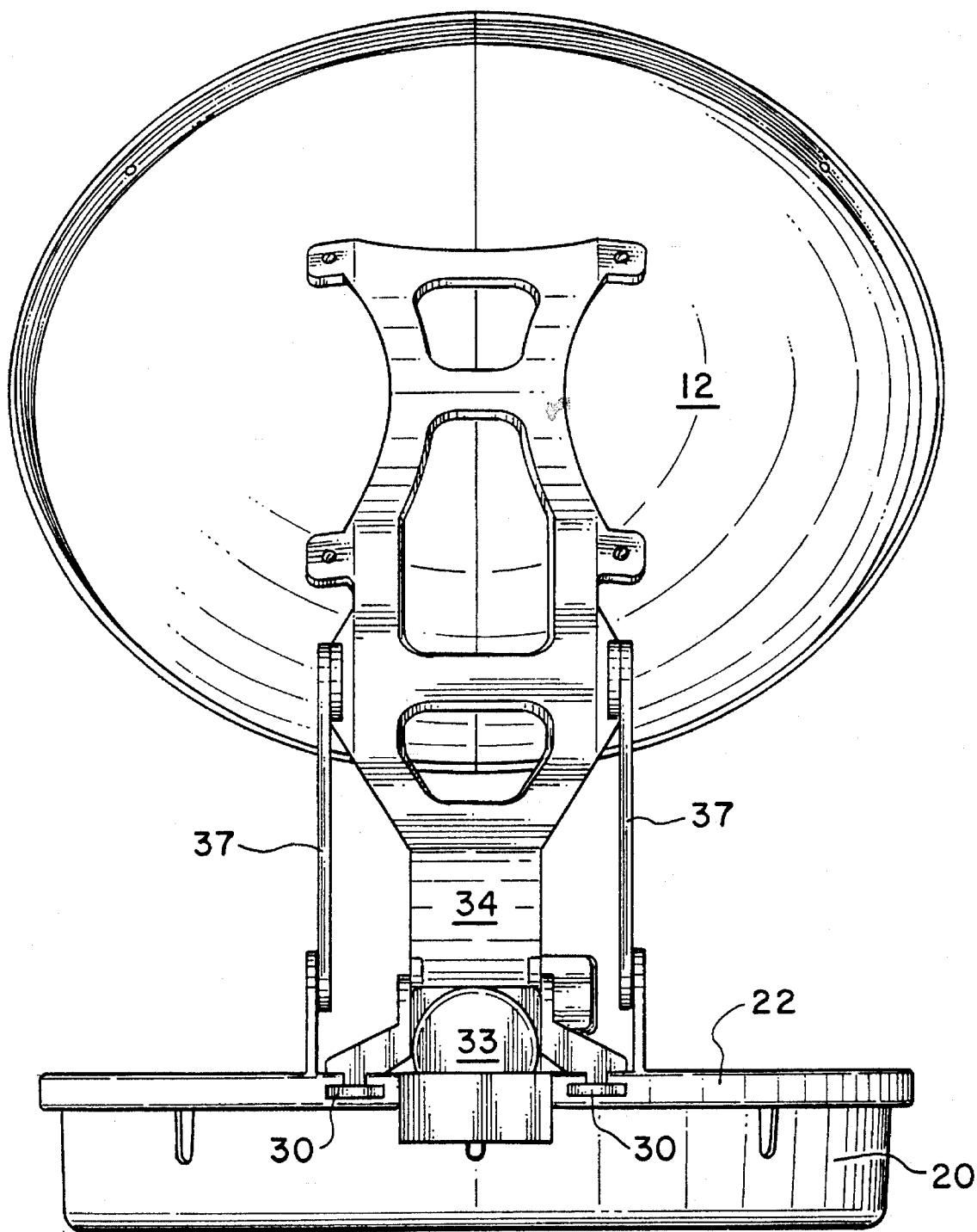

Fig. 13

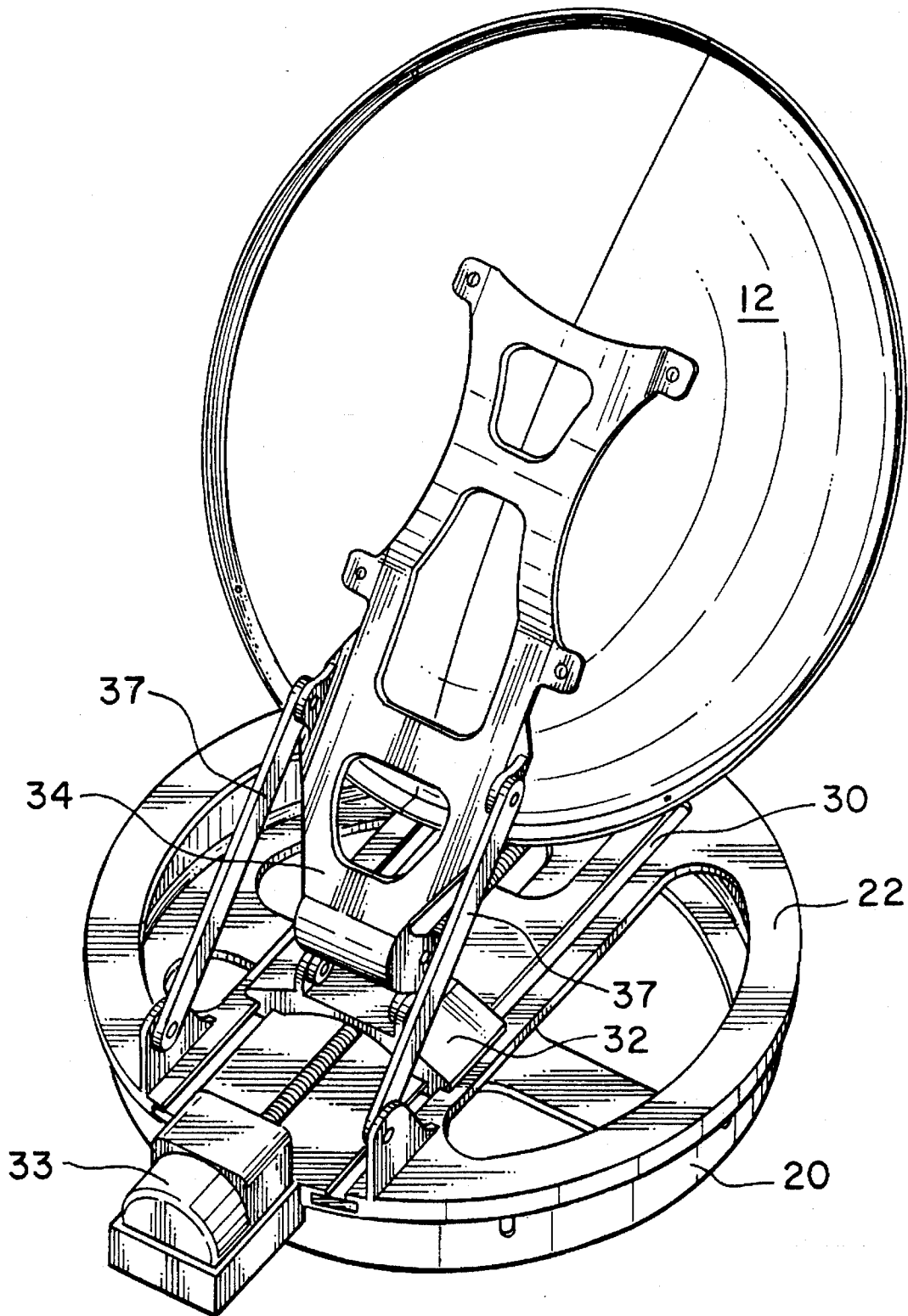

Fig. 14

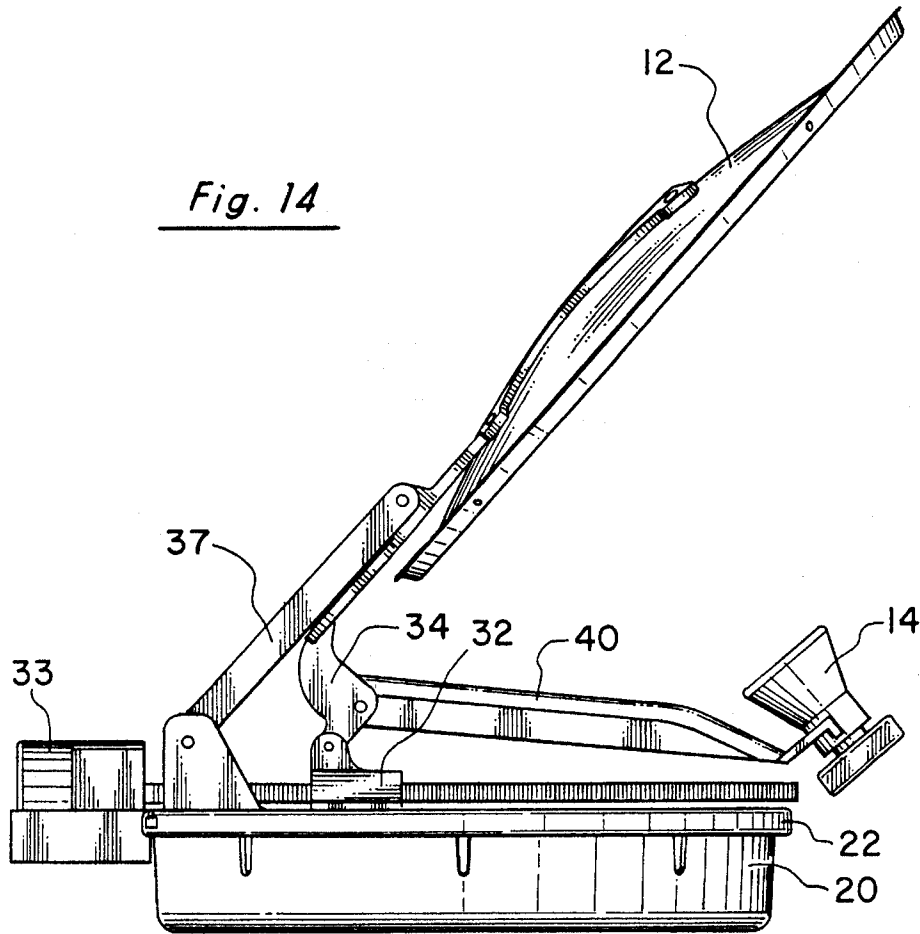
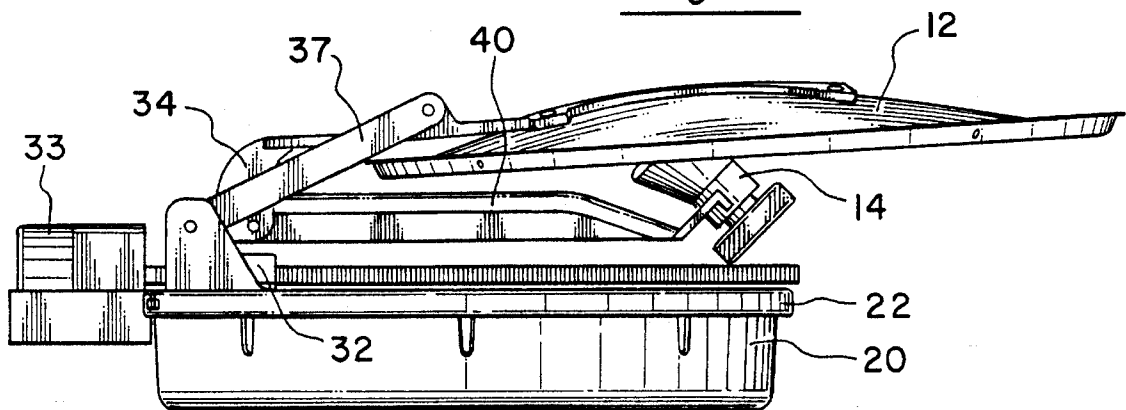

Fig. 15



DEPLOYABLE SATELLITE ANTENNA FOR USE ON VEHICLES

RELATED APPLICATION

The present application is a continuation-in-part of U.S. patent application Ser. No. 08/265,392, filed Jun. 24, 1994, U.S. Pat. No. 5,418,542, entitled "Deployable Satellite Antenna For Use On Vehicles", which is a continuation of Ser. No. 977,907, filed Nov. 18, 1992, now U.S. Pat. No. 5,337,062, issued on Aug. 9, 1994.

BACKGROUND OF THE INVENTION

1. Field of the Invention

The present invention relates generally to the field of satellite antennas. More specifically, the present invention discloses a deployable satellite antenna intended especially for use on a vehicle, such as a recreational vehicle.

2. Statement of the Problem

Antennas have enjoyed increasing popularity in recent years for the purpose of receiving television signals from orbiting satellites. Satellite antennas are perhaps most widely used in small towns and rural areas that are not served by cable television systems. However, a market for satellite antennas also exists for recreational vehicles, such as motor homes, campers, trailers, mobile homes, and the like, that can be moved to remote locations not serviced by conventional cable television systems. A number of special considerations come into play when adapting an antenna for use on such a vehicle. First, it should be possible to readily stow the antenna while the vehicle is traveling to minimize aerodynamic resistance and to reduce the risk of damage to the antenna, its ancillary equipment, and the vehicle resulting from aerodynamic loads and other mad hazards. Second, the antenna should be able to be positioned to virtually any azimuth and elevation. With a conventional ground-based antenna, it is sometimes possible to accept a limited range of azimuths or elevations for an antenna given the known relative locations of the satellites and the antenna. In the case of an antenna mounted on a vehicle that can be moved over a wide geographic area and parked in any azimuth orientation, such restrictions are not acceptable and a full range of possible azimuth and elevation positions are necessary for the antenna. Third, the antenna system should be relatively compact while stowed and while deployed, so as not to interfere with any other objects (e.g., the air conditioning unit, vents, or luggage rack) located on the roof of a typical recreational vehicle. Finally, the system should be designed to use conventional electric motors to accurately control the motion of the mechanical linkages to position the antenna without discontinuities or singularities.

A number of deployable antennas have been invented in the past, including the following:

Inventor	Patent No.	Issue Date
Tsuda	4,937,587	June 26, 1990
Yamada	4,887,091	Dec. 12, 1989
Bruinsma et al.	4,868,578	Sep. 19, 1989
Bissett	4,811,026	Mar. 7, 1989
Radov	4,710,778	Dec. 1, 1987
Wilson	4,663,633	May 5, 1987
Shepard	4,602,259	July 22, 1986
	Japan 60-260207	Dec. 23, 1985
	Japan 60-260205	Dec. 23, 1985
	Japan 60-233905	Nov. 20, 1985
Weir	4,490,726	Dec. 25, 1984

-continued

Inventor	Patent No.	Issue Date
Sayovitz	4,309,708	Jan. 5, 1982
	Japan 55-53903	Apr. 19, 1980
Budrow, et al.	3,739,387	June 12, 1973
Budrow, et al.	3,665,477	May 23, 1972
Budrow, et al.	3,587,104	June 22, 1971
Bergling	3,412,404	Nov. 19, 1968

Tsuda discloses a low profile scanning antenna having an arcuately shaped track. A carriage supporting the antenna dish moves along the inside of the arcuate track.

Yamada discloses a receiving antenna for vehicles having a horizontally rotatable base plate with a main reflector tiltably attached to the edge of the base plate. A sub-reflector is mounted at the end of an arm extending from the base plate.

Bruinsma et al. disclose a portable reflector antenna assembly having a triangular base frame employing three beam members that are joined together at their ends with hinge type knuckles which are slidably positioned on three legs. The frame can be adjusted on the legs for both height and leveling by virtue of the slidable movement of each of the knuckles along the legs. When the desired position, the knuckles are clamped to the legs by means of lever-cam actuated draw bolts. The reflector is supported along its rim by pivotal supports and clamps. The bottom edge of the reflector is slidably adjustable in azimuth along the front beam member of the frame. The top edge of the reflector is supported for slidable elevation adjustment along a shaft which extends upward from the rear leg.

Bissett discloses a mobile satellite receiving antenna especially for use on recreational vehicles. A generally cylindrical collar extends upward from the vehicle roof. A parabolic reflector is hinged along an edge to a horizontal turntable within the collar so that the reflector may be rotated to a concave downward position to serve as a weather cover over the collar and also to provide smooth aerodynamic conditions during transport.

Radov discloses a modular earth station for satellite communications having a frame adapted to be installed in an inclined roof. A concave antenna is adjustably mounted to the frame and covered by a rigid canopy.

Wilson discloses a vehicle-mounted satellite antenna system having a base plate mounted on the vehicle roof, a support member rotatably secured to the base plate to permit rotation about a vertical axis, and a parabolic reflector pivotally secured to the support member. The feed arm is pivotally secured to one end of the parabolic reflector. When the antenna is deployed, the feed arm is automatically pivoted to a position wherein the feed horn is coincident with the focus of the reflector. When the antenna is returned to its rest position, the feed arm is automatically pivoted so that the feed horn is retained within the confines of the interior surface of the reflector.

Shepard discloses a polar mount for a parabolic satellite-tracking antenna.

Japanese Patent Nos. 60-260207 and 60-260205 disclose a vehicle-mounted antenna that can be stowed with the dish in a face-down position against the roof of the vehicle.

Japanese Patent No. 60-233905 discloses an antenna having a feed arm that permits the feed horn to be stowed in a position adjacent to the surface of the dish.

Weir discloses a collapsible rooftop parabolic antenna. The antenna has a horizontal pivot that provides axial

displacement if axial wind forces on the antenna exceed a predetermined limit. This limits the torque transmitted to the roof on which the antenna is mounted to a reasonably low level.

Sayovitz discloses a foldable disk antenna supported on a framework resting on the bed of a truck or trailer. Folding legs on the framework can be extended to contact the ground to support the antenna.

Japanese Patent No. 55-53903 discloses a satellite antenna with a tracking system that allows the antenna to be stowed.

The patents to Budrow, et al. disclose several embodiments of a TV antenna suitable for mounting upon the roof of a recreational vehicle. The direction of the antenna can be controlled from the vehicle interior. In addition, the antenna dipoles can be folded to a closed position when the vehicle is transported.

Bergling discloses a dish reflector having a stowed position.

3. Solution to the Problem

None of the prior art references uncovered in the search show a deployable antenna system having the structure of the present invention. In particular, the mechanism used to control and adjust the elevation of the antenna in the present invention is neither taught nor suggested by the prior art.

SUMMARY OF THE INVENTION

This invention provides a deployable satellite antenna system with elevation and azimuth controls that can be mounted on the roof of a vehicle. The elevation control assembly for the antenna system has a base with two parallel tracks and a slider that moves along these tracks. The antenna reflector is connected to a support frame pivotally attached to the slider. Pivot arms are pivotally attached between the reflector and the base adjacent to the parallel tracks. The elevational position of the reflector is adjusted by a motor which controls the position of the slider along the parallel tracks between a stowed position in which the reflector is stowed facing the vehicle and a deployed position in which the reflector is rotated to a maximum elevational angle. In one embodiment, a feed arm supporting the feed horn extends outward from the antenna support frame adjacent to the lower edge of the antenna. The base of the feed arm is pivotally attached to the support frame so that the feed horn is stored beneath the antenna in its stowed position and moves to a predetermined point relative to the antenna in its deployed position. The azimuth of the antenna is controlled by a rotating assembly mounted to the roof of the vehicle beneath the base of the elevation control assembly.

A primary object of the present invention is to provide a deployable antenna that can be readily mounted to the roof of a vehicle, such as a typical recreational vehicle.

Another object of the present invention is to provide a deployable antenna that can be stowed face down and that can be quickly and accurately positioned to virtually any azimuth and elevational orientation.

Yet another object of the present invention is to provide a deployable antenna that is relatively compact while stowed and while deployed, so as not to interfere with other objects (e.g., the air conditioning unit, vents, or luggage rack) located on the roof of a recreational vehicle.

These and other advantages, features, and objects of the present invention will be more readily understood in view of the following detailed description and the drawings.

BRIEF DESCRIPTION OF THE DRAWINGS

The present invention can be more readily understood in conjunction with the accompanying drawings, in which:

FIG. 1 is a perspective view of the entire satellite antenna assembly.

FIG. 2 is a side view of the antenna in its stowed position. The roof of the vehicle is shown in cross-section and a portion of the reflector is cut away to reveal the feed horn and the feed frame assembly.

FIG. 3 is a side view of the antenna in a partially deployed position. The roof of the vehicle is shown in cross-section and a portion of the reflector is cut away to reveal the base of the feed frame assembly.

FIG. 4 is a side view of the antenna in a more fully deployed position than shown in FIG. 3.

FIG. 5 is a side view of the antenna in its fully deployed position.

FIG. 6 is a perspective view of the azimuth control assembly of the antenna.

FIG. 7 is a rear perspective view of the fully deployed antenna corresponding to FIG. 5.

FIG. 8(a) is a perspective view showing the attachment of the feed frame assembly to the reflector.

FIG. 8(b) is a partial front view providing further detail of the attachment of the feed frame assembly to the reflector.

FIG. 8(c) is an exploded perspective view of the feed frame assembly.

FIG. 9 is a perspective view showing the range of motion of the slide assembly and elevation control motor between the stowed position and the fully deployed position of the antenna.

FIG. 10 is a perspective view of an alternative embodiment of the present invention in its fully deployed position.

FIG. 11 is a side view of the alternative embodiment corresponding to FIG. 10.

FIG. 12 is a rear view of the alternative embodiment corresponding to FIG. 10 but in a partially deployed position.

FIG. 13 is a rear perspective view of the alternative embodiment in a partially deployed position.

FIG. 14 is a side view of the alternative embodiment in a partially deployed position.

FIG. 15 is a side view of the alternative embodiment in its fully stowed position.

DETAILED DESCRIPTION OF THE INVENTION

As shown in FIG. 1, the antenna system includes a reflector 12 having a substantially parabolic face to focus radio signals toward a predetermined focal point relative to the reflector 12. A feed horn 14 is positioned at this focal point when the antenna system is in its deployed state, as depicted in FIG. 1, to receive the radio signals reflected from the face of the reflector 12.

The entire system is attached to the roof of a vehicle 10, such as a recreational vehicle or a trailer, by means of a stationary frame 21. A stationary ring 20 is attached in turn to the stationary frame 21. A rotating ring 22 rides above the stationary ring 20, as shown most clearly in FIG. 6, and provides a rotating base or platform for the remainder of the system about a predetermined azimuth axis. In a typical installation, this azimuth axis extends vertically upward

from the roof of the vehicle 10 through the center of the stationary ring 20 and the rotating ring 22. The azimuth orientation of the rotating ring 22 is controlled by an electric motor 26 attached to the rotating ring 22 which drives a worm 28 that meshes with the azimuth worm gear 24 attached to the stationary frame 21, as shown in FIG. 6. For example, the azimuth control motor 26 can be a DC motor that rotates the worm gear 28. The DC motor sends pulses back to its external controller as it rotates the azimuth assembly. These pulses are counted, and this information can then be used by the controller to monitor and control angular motion of the DC motor.

A number of parallel tracks 30 are mounted to the rotating ring 22 and extend substantially perpendicular to the azimuth axis. The preferred embodiment shown in the drawings uses two parallel tracks 30. A slider assembly 32 moves along these tracks 30. Alternatively, an assembly on wheels, or other equivalent means for translational motion along the parallel tracks 30 could be employed. The position of the slider assembly 32 along the tracks 30 is governed by a second motor 33. In the preferred embodiment, an electric motor drives a linear screw to adjust the horizontal position of the slider assembly 32 along the tracks 30. As will be described in further detail below, the motor 33 and slider assembly 32 control the elevational angle of the reflector 12.

The reflector 12 is supported by the upper portion of the reflector frame assembly 34 attached to the rear of the reflector 12. The lower portion of the reflector frame assembly 34 is pivotally attached to the slider assembly 32. This structure effectively permits elevational rotation of the reflector 12 about the lower end of the reflector frame assembly. Two supports 35 extend upward from the rotating ring 22 adjacent to parallel tracks 30. Two pivot arms 37 are connected between the reflector frame assembly 34 and the upper ends of the supports 35. In particular, the first end of each pivot arm 37 is pivotally attached to the upper end of one of the supports 35, while the other end is pivotally attached to the mid-section of the reflector frame assembly 34 adjacent to the rear of the reflector 12. Two additional front supports 38 with rubber bumpers extend upward from the rotating ring assembly 22 adjacent to the other ends of the parallel tracks 30. The reflector 12 rests against the rubber bumpers of the front supports 38 when stowed as shown in FIG. 2.

When the reflector 12 is deployed, the feed horn 14 must be positioned at the focal point of the reflector 12. The feed horn 14 is supported by the distal end of the feed frame assembly 40. The base of the feed frame assembly 40 is pivotally attached near the periphery of the reflector 12 as shown in FIGS. 1 through 5. A long feed pivot arm 42 is pivotally attached at its base end to the reflector 12 and is also pivotally or slidably attached at its mid-section to the mid-section of the feed frame assembly 40. Alternatively, the base end of the feed pivot arm 42 can be pivotally attached directly to the reflector frame assembly 34 through an opening in the reflector 12. The distal end of the feed pivot arm 42 is designed to come into contact with the base of the unit as the reflector 12 is rotated to its stowed position. This contact causes the feed frame assembly 40 to fold the feed horn 14 to a position adjacent to the face of the reflector 12 as the reflector moves toward its stowed position. In the preferred embodiment depicted in FIGS. 8(a) through 8(c), the feed pivot arm consists of two segments 42 and 44 connected together by a hinge and spring mechanism that tends to keep the segments in a co-linear relationship until the distal end of the outer segment comes into contact with the base.

FIGS. 2 through 5 demonstrate the system moving from its stowed position (FIG. 2) to its fully deployed position (FIG. 5). FIG. 9 depicts the range of motion of the slider assembly 32 with respect to the parallel tracks 30. In particular, FIG. 9 shows how the elevation control motor 33 moves the slider assembly 32 along the parallel tracks 30 toward the motor 33 in order to raise the reflector 12 from the stowed position to the deployed position. It should be noted that in the stowed position shown in FIG. 2, the slider assembly 32 is distal from the elevation control motor 33. The reflector 12 faces the roof of the vehicle 10. The end of the feed pivot arm 42 is in contact with the base of the unit, thereby causing the feed frame assembly 44 and feed horn 14 to be rotated to positions adjacent to the surface of the reflector 12 for storage. In this stowed position, the elevational control motor 33, slider assembly 32, feed horn 14, feed frame assembly 44, azimuth gear 24, and azimuth control motor 26 are all covered by the reflector 12 to provide a degree of protection from the elements.

In FIG. 3, the elevation control motor 33 has drawn the slider assembly 32 and the proximal portion of the reflector 12 along the parallel tracks 30 to a position slightly closer to the motor 33. This slightly raises the opposite distal portion of the reflector 12 off the forward supports 38 and thereby causes a slight upward rotation of the reflector 12 as shown. However, the end of the feed pivot arm 42 remains in contact with the base of the unit. The segments 42 and 44 of the pivot arm gradually straighten as the reflector 12 rotates upward, but the feed frame assembly 40 and the feed horn 14 are not yet lifted from their stowed positions.

FIG. 4 continues the deployment process to the point where the end of the feed pivot arm 42 is no longer in contact with the base of the unit. The slider assembly 32 and the proximal portion of the reflector 12 have been moved closer to the elevation control motor 33 and the face of the reflector 12 has thereby been rotated upward to a greater elevational angle. The segments 42 and 44 of the feed pivot arm have straightened to a co-linear relationship with one another, and lift the feed frame assembly 40 and the feed horn 14 from their stowed positions by rotating the feed frame assembly 40 about its base attached to the face of the reflector 12. The feed horn 14 is now positioned at the focal point of the reflector 12.

In FIG. 5, the reflector 12 has reached its fully deployed position with the face of the reflector 12 pointed upward. The slider assembly 32 and the proximal portion of the reflector 12 have been drawn forward to their most proximal position with respect to the elevation control motor 33. The two segments 42 and 44 of the feed pivot arm remain in a co-linear relationship due to the spring mechanism. The feed horn 14 remains positioned at the focal point of the reflector 12 as before. The procedure shown in FIGS. 2 through 5 is simply reversed to stow the antenna.

FIGS. 10 through 15 show an alternative embodiment of the present invention in which the design of the feed arm 40 has been significantly simplified. FIG. 10 provides a perspective view of the reflector 12 in its fully deployed position. A corresponding side view is illustrated in FIG. 11 and corresponding rear view is depicted in FIG. 12. In this embodiment, the base of the feed arm 40 is pivotally attached to the reflector frame 34, instead of being secured to the face of the reflector as shown in the first embodiment. The feed horn 14 is supported by the distal end of the feed arm 40. Gravity causes the feed arm to rotate downward relative to the remainder of the reflector assembly as the reflector assembly moves upward from its stowed position to its deployed position. However, a rib or protrusion on the

reflector frame 34 stops the downward rotation of the feed arm 40 relative to the reflector frame 34 at a preselected position. For example, FIGS. 13 and 14 provide a rear perspective view and a side view, respectively, of the antenna assembly in a partially deployed state. This feature causes the feed horn 14 to automatically move to a predetermined point relative to the face of the reflector 12 to receive signals when the reflector assembly is deployed. Rotation of the feed arm 40 relative to the reflector frame 34 during deployment can be assisted by a spring, if necessary. This spring can also be used to exert a biasing force that tends to hold the feed arm 40 in place against the stop on the reflector frame 34 while the antenna system is in operation. As the reflector assembly moves from its deployed position to its stowed position, the feed arm 40 rotates downward with the reflector frame 34 until the feed horn 14 comes into contact with the base of the unit. As the reflector assembly continues to rotate downward beyond this point of contact, the feed horn 14 remains essentially stationary and the base of the feed arm 40 pivots freely upward relative to the reflector frame 34. This relative motion between the feed arm and the remainder of the reflector assembly causes the feed horn 14 to assume a position beneath the reflector 12 as the reflector is lowered to its stowed position shown in FIG. 15.

The present invention offers a number of advantages over the prior art. Its simpler design requires fewer component pieces, which makes the system significantly less expensive, easier to assemble, and more reliable. The present invention can be stowed into a smaller space. The simplicity of this design also makes it less susceptible to damage and grit from being exposed to hostile environments on top of a vehicle. The present invention also allows smaller motors to be used, which further reduces costs and saves space when stowed.

The above disclosure sets forth a number of embodiments of the present invention. Other arrangements or embodiments, not precisely set forth, could be practiced under the teachings of the present invention and as set forth in the following claims.

We claim:

1. A deployable antenna system to be mounted on a support surface, said antenna system comprising:

a reflector having a face, a proximal portion adjacent said support surface, and a distal portion that is remote from said support surface when said antenna system is deployed;

a feed horn for receiving electrical signals reflected by said reflector;

azimuth control means for rotating said reflector in an azimuth direction with respect to said support surface;

elevation control means coupled to said azimuth control means and to said reflector for raising said reflector in an elevational direction, having:

(a) a track substantially parallel to said support surface;

(b) slider means for translational movement along said track;

(c) a reflector frame having a lower portion pivotally attached to said slider means and an upper portion attached to said reflector;

(d) a reflector pivot arm having a first portion pivotally attached with respect to said reflector and a second portion pivotally attached to a predetermined point relative to said track; and

(e) means for adjustably controlling the position of said slider means along said track between said stowed position and said deployed position, thereby causing

the proximal portion of said reflector to slide in a direction across said azimuth control means to raise the distal portion of said reflector from a stowed position wherein said reflector faces said support surface to a deployed position wherein said reflector faces upward; and

a feed arm having a base portion pivotally attached to said reflector frame and a distal portion supporting said feed horn, said feed arm stowing said feed horn beneath said reflector in said stowed position and moving said feed horn to a predetermined point relative to said face of said reflector when not in said stowed position.

2. The antenna system of claim 1 wherein said support surface comprises the roof of a vehicle.

3. The antenna system of claim 1 wherein said azimuth control means comprise:

a stationary ring mounted to said support surface;

an azimuth ring supported by said stationary ring for rotation about an azimuth axis; and

drive means for selectively rotating said azimuth ring to a desired orientation about said azimuth axis.

4. A deployable antenna system to be mounted on a vehicle or the like, said antenna system comprising:

a base mounted to said vehicle;

a reflector having a face;

a feed horn for receiving electrical signals reflected by said reflector;

an elevation control assembly for supporting said reflector on said base and adjustably controlling the elevational angle of said reflector, said elevation control assembly having:

(a) at least one parallel track;

(b) slider means for translational movement along said track;

(c) a reflector frame having a lower portion pivotally attached to said slider means and an upper portion attached to said reflector;

(d) at least one pivot arm, each having a first portion pivotally attached with respect to said reflector and a second portion pivotally attached to said base; and

(e) means for adjustably controlling the position of said slider means along said track between a stowed position in which said reflector is stowed facing said vehicle and a deployed position in which said reflector is rotated to a maximum elevational angle; and

a feed arm having a base portion pivotally attached to said reflector frame and a distal portion supporting said feed horn, said feed arm stowing said feed horn beneath said reflector in said stowed position and moving said feed horn to a predetermined point relative to said face of said reflector when not in said stowed position.

5. The antenna system of claim 4 further comprising azimuth control means for supporting and adjustably controlling rotation of said reflector with respect to said base about an azimuth axis.

6. The antenna system of claim 5 wherein said azimuth control means comprise:

a platform supported by said base for rotation about said azimuth axis; and

drive means for selectively rotating said platform to a desired orientation about said azimuth axis.

7. The antenna system of claim 4 wherein said second portion of said pivot arm is pivotally attached to a support extending upward from said base toward said reflector adjacent to said parallel track.

9

8. A deployable antenna system mounted on the roof of a recreational vehicle, said antenna system comprising:

a reflector having a face and a proximal portion adjacent said roof of said vehicle;

azimuth control means for rotating said reflector about an azimuth axis substantially perpendicular to said roof;

a track supported by said azimuth control means extending substantially parallel to said roof;

means for translational movement along said track coupled to a first end of said reflector;

elevation control means coupled to said translational means for raising said reflector in an elevational direction with respect to said roof, said elevational control means causing said translational means and said proximal portion of said reflector to translate along said track to raise of said reflector from a stowed position wherein said reflector faces said roof to a deployed position in which said reflector faces upward; and

10

a feed arm having a base portion pivotally attached relative to said proximal portion of said reflector and a distal portion supporting said feed horn, said feed arm stowing said feed horn beneath said reflector in said stowed position and moving said feed horn to a predetermined point relative to said reflector when not in said stowed position.

9. The antenna system of claim 8 wherein said azimuth control means comprise:

a stationary ring mounted to said roof;

an azimuth ring supported by said stationary ring for rotation about an azimuth axis; and

drive means for selectively rotating said azimuth ring to a desired orientation about said azimuth axis.

* * * * *