



US 20040207566A1

(19) **United States**

(12) **Patent Application Publication**

Essig, JR. et al.

(10) **Pub. No.: US 2004/0207566 A1**

(43) **Pub. Date: Oct. 21, 2004**

(54) **MODULAR INFLATABLE MULTIFUNCTION
FIELD-DEPLOYABLE APPARATUS AND
METHODS OF MANUFACTURE**

Publication Classification

(51) **Int. Cl.7** **H01Q 1/12**

(52) **U.S. Cl.** **343/878**

(76) Inventors: **John Raymond Essig JR.**, Jupiter, FL
(US); **James Michael Essig**, Fairfax,
VA (US)

(57) **ABSTRACT**

Correspondence Address:

John R. Essig, Jr.

P.O. Box 3333

Fairfax, VA 22038-3333 (US)

An modular, inflatable, multifunction, multipurpose, parabolic reflector apparatus having a plurality of manufactured parabolic mirrors made from a pressure-deformable reflective covering of an inflatable ring for focusing electromagnetic energy from radio frequency radiation (RF) through the ultraviolet radiation (UV) and solar energy for (1) heating and cooking, for (2) electrical power generation, for (3) enhancing the transmission and reception of radio signals, for (4) enhancing vision in low-light environments, and for (5) projection of optical signals or images. The device also has non-electromagnetic uses, such as the collection of water. A first main embodiment utilizes two reflective membranes. A second main embodiment utilizes a reflective membrane and a transparent membrane. Portability is enhanced by complete collapsing of the inflatable device.

(21) Appl. No.: **10/729,145**

(22) Filed: **Dec. 4, 2003**

Related U.S. Application Data

(63) Continuation-in-part of application No. 10/156,814, filed on May 30, 2002.

(60) Provisional application No. 60/294,440, filed on May 30, 2001.

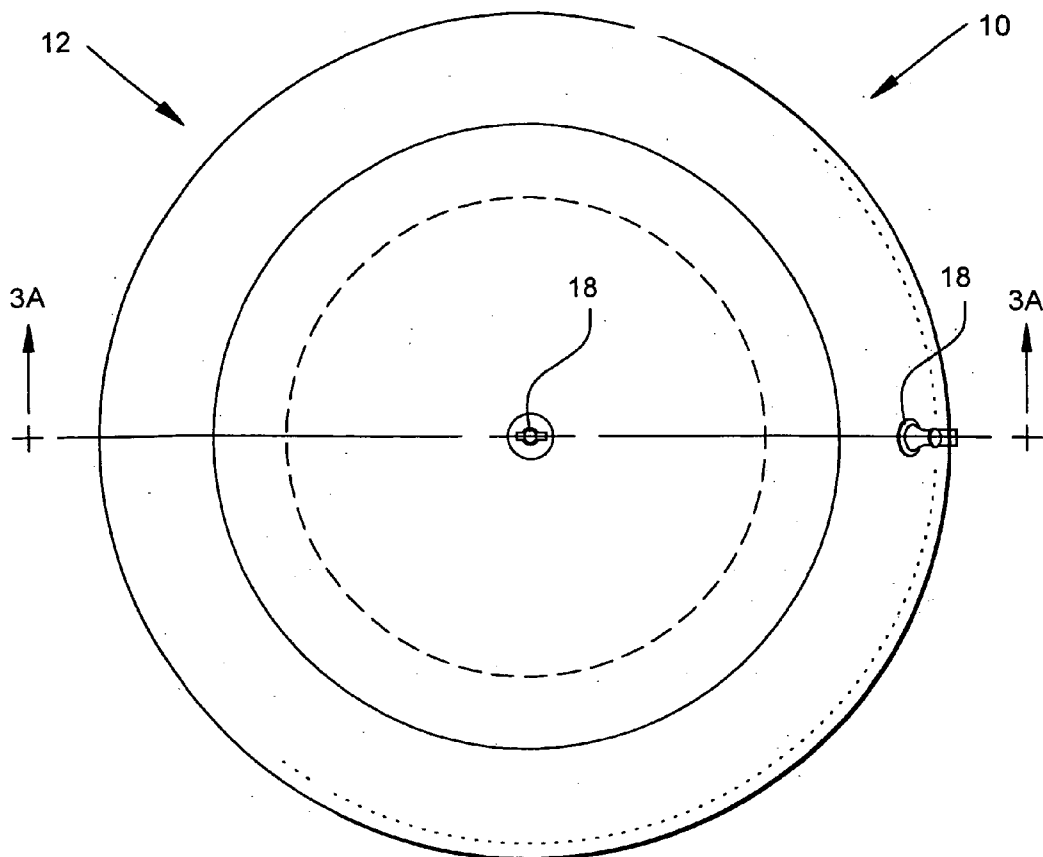

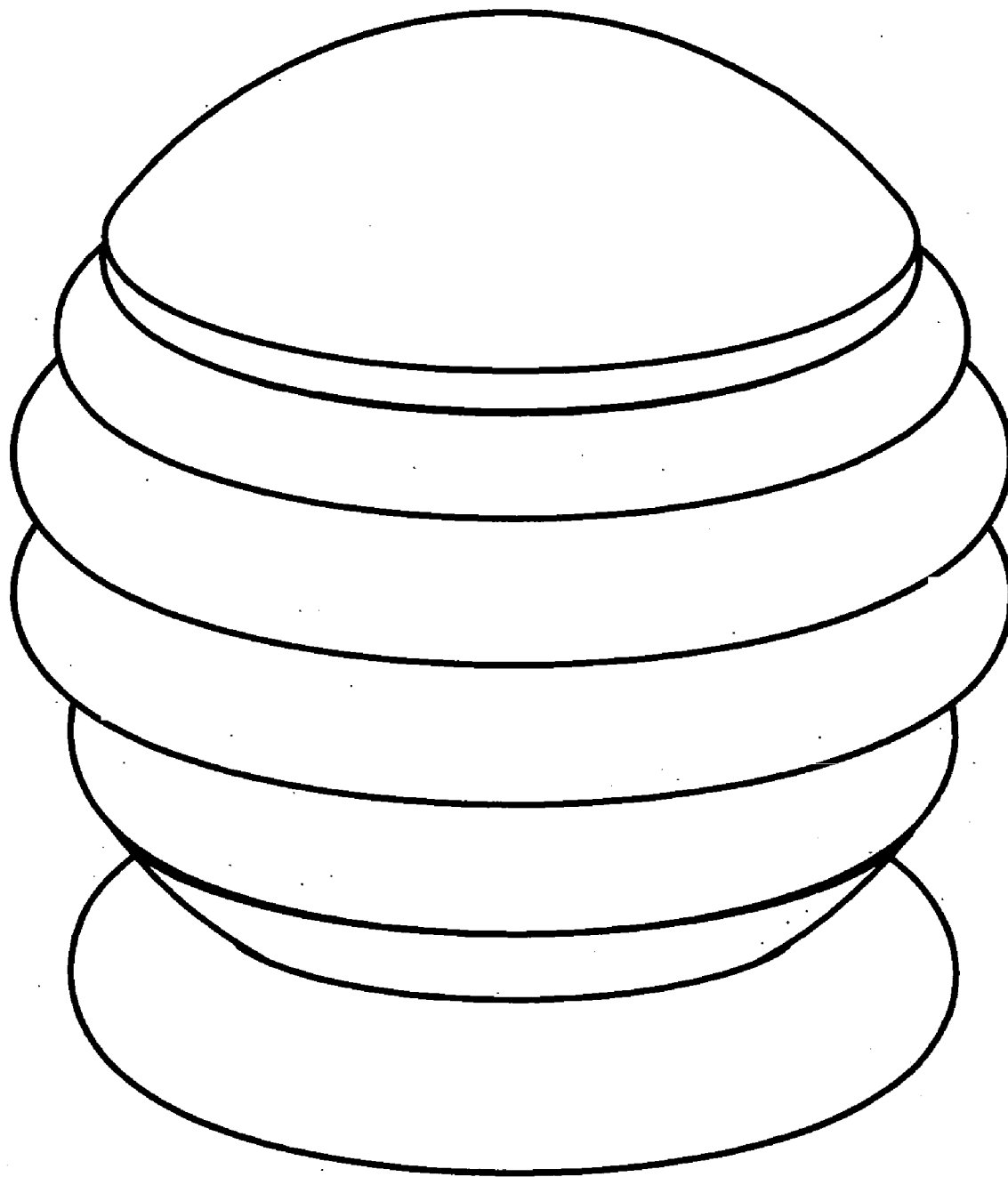

FIG. 1A

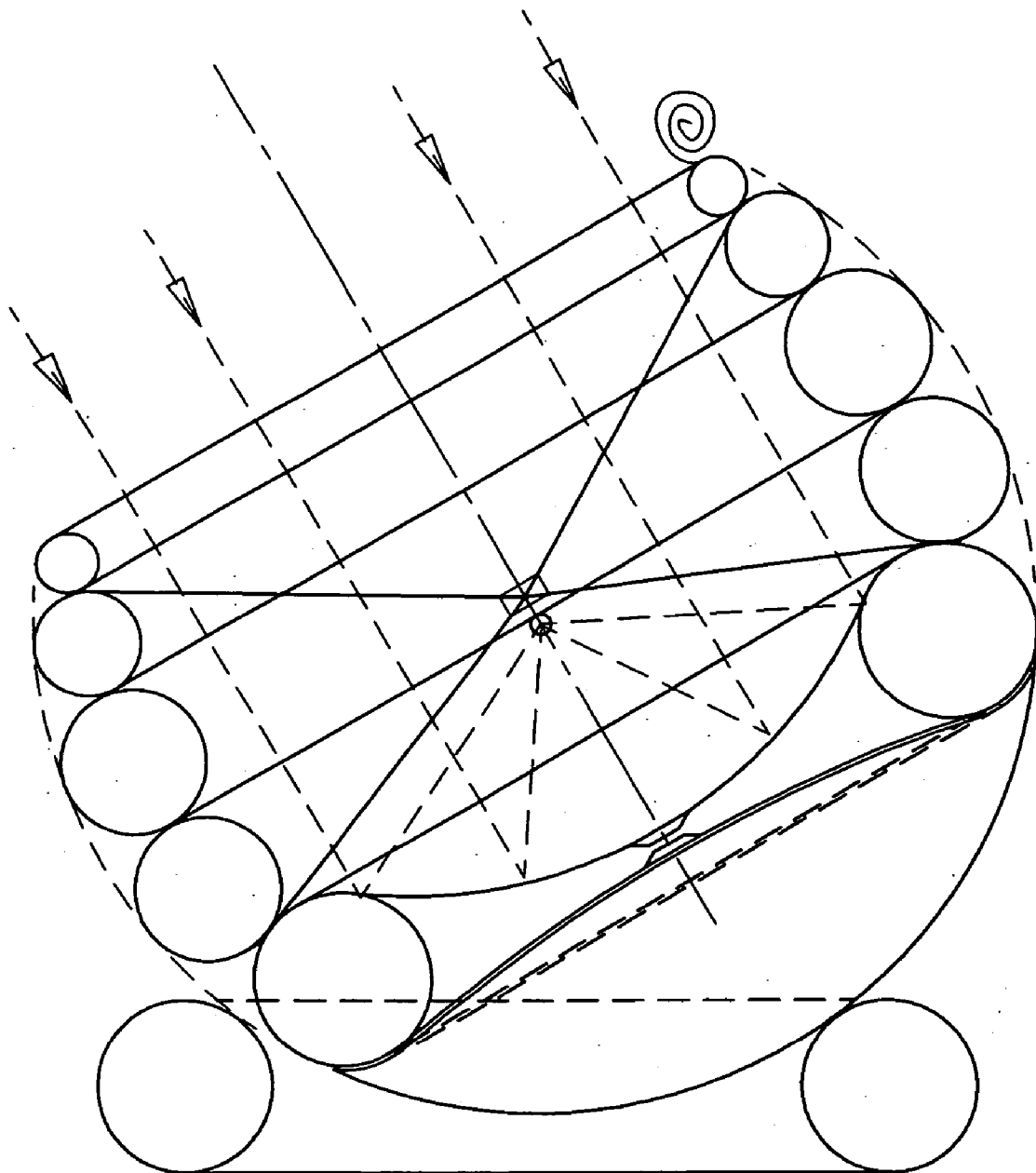

FIG. 1B

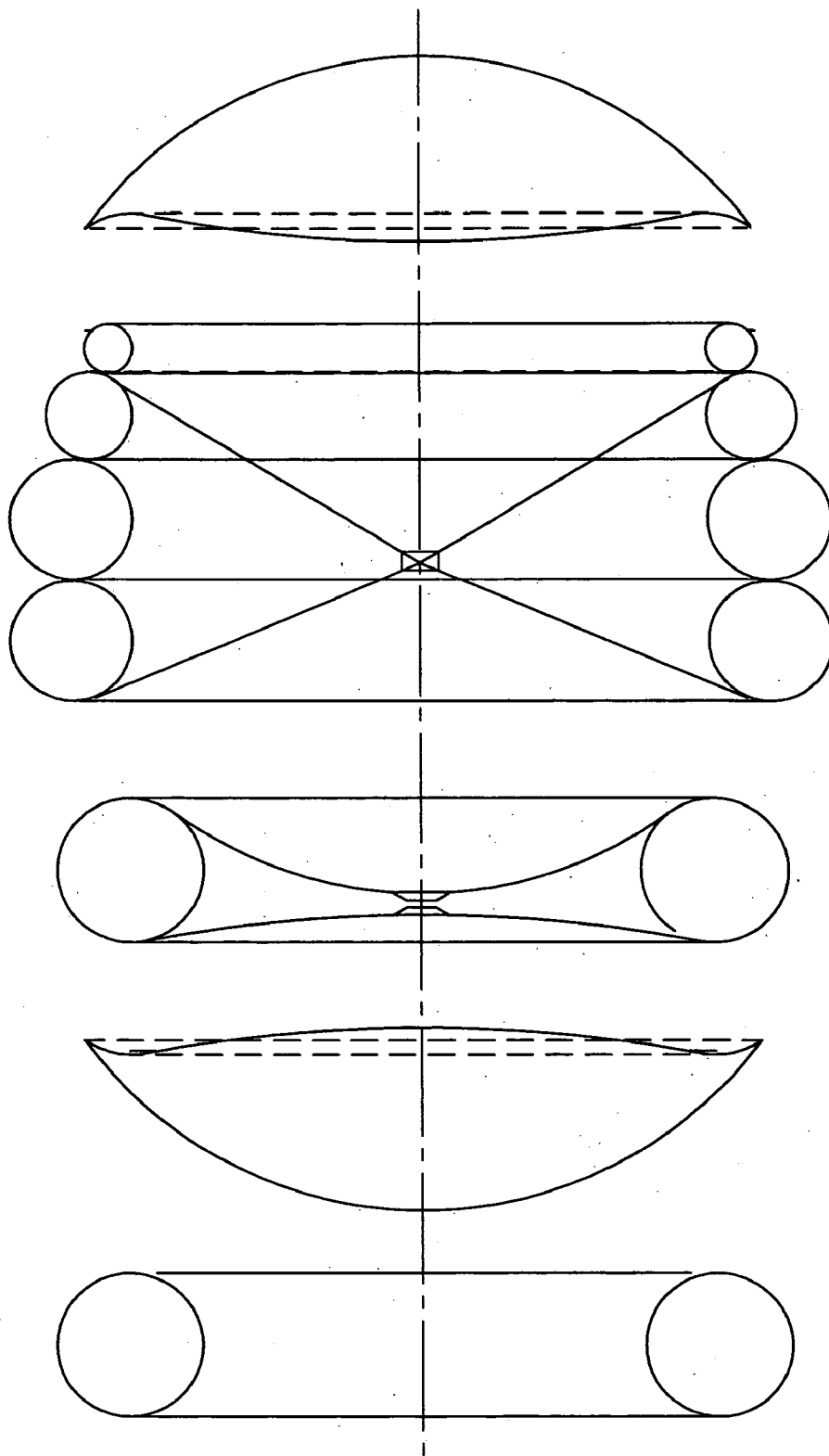

FIG. 1C

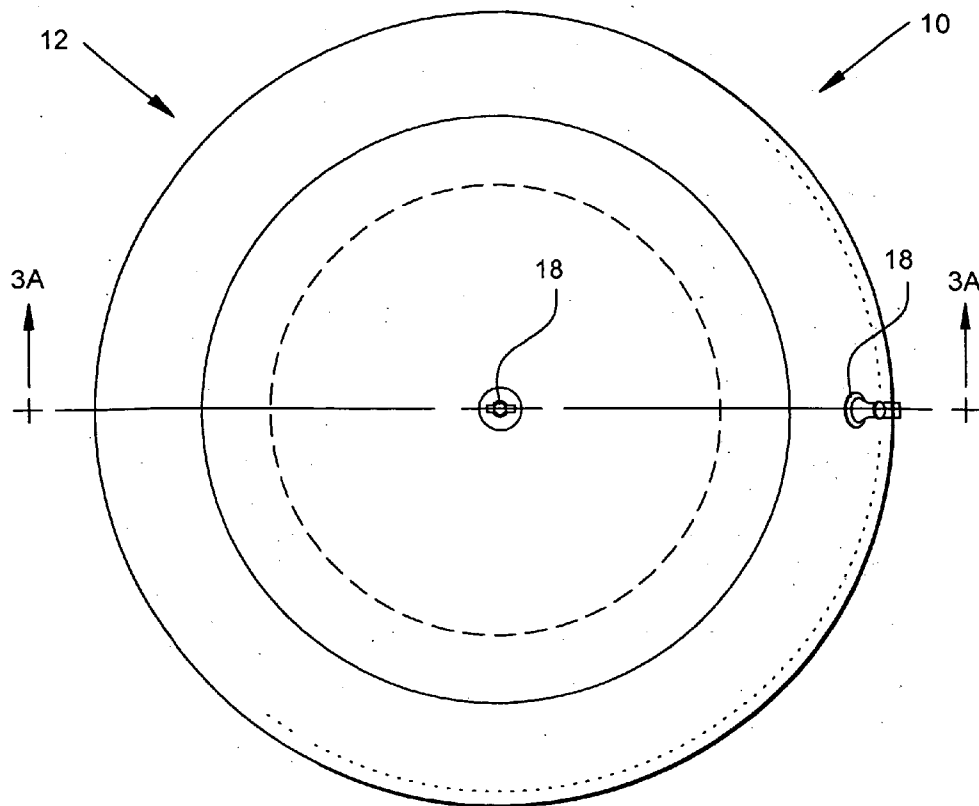

FIG. 2A

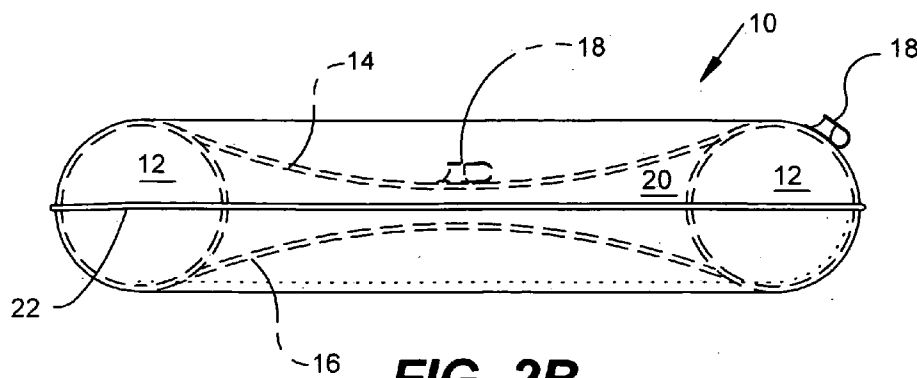

FIG. 2B

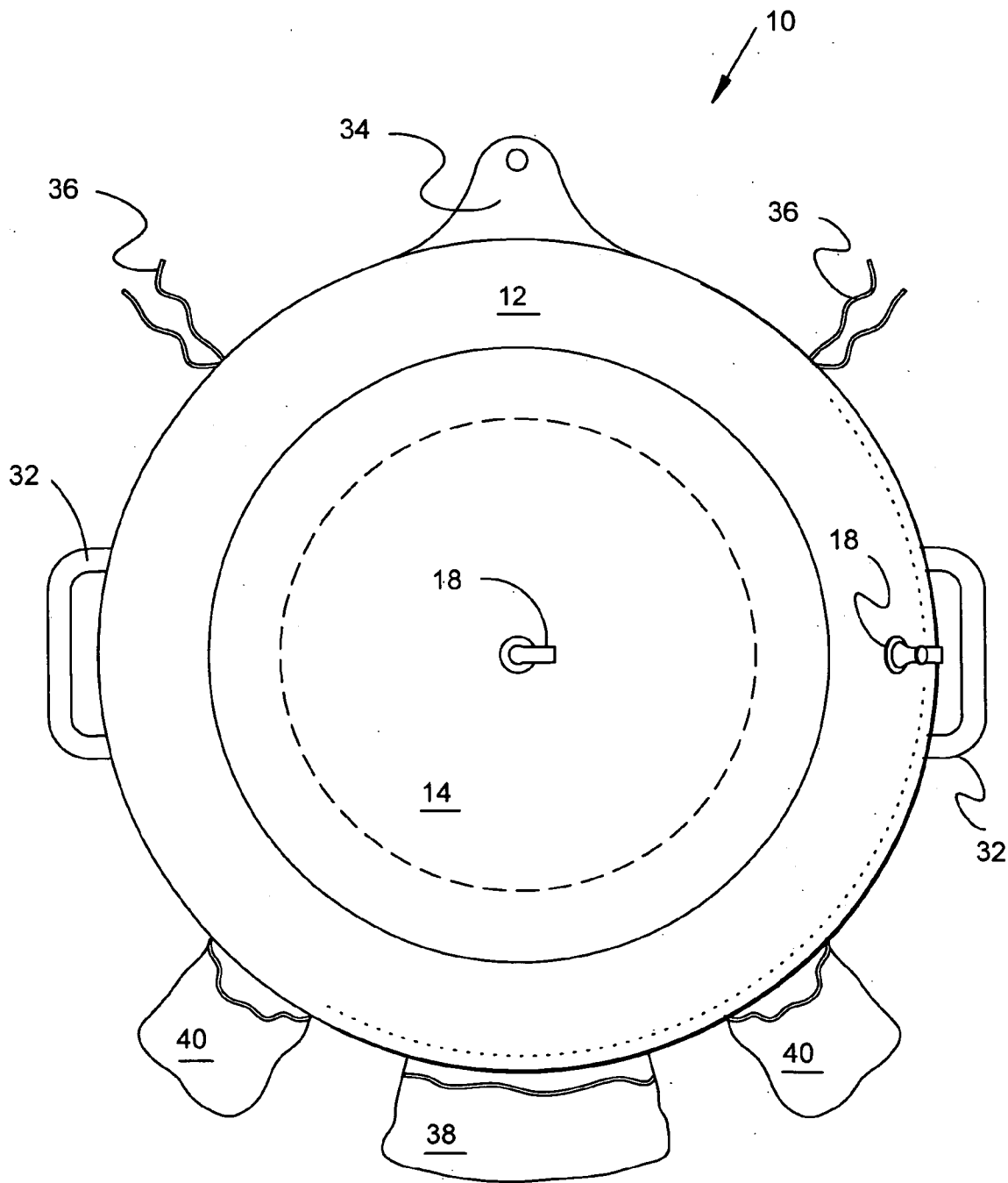

FIG. 2C

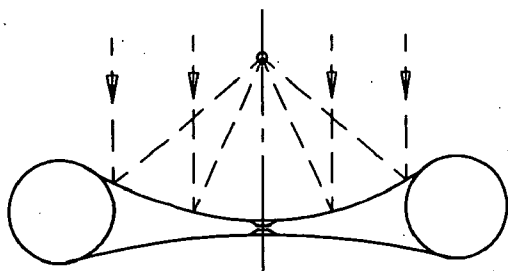

FIG. 3C

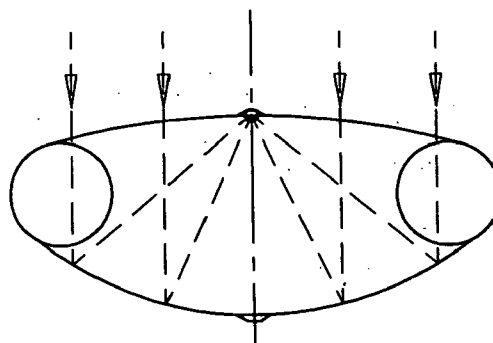

FIG. 3D

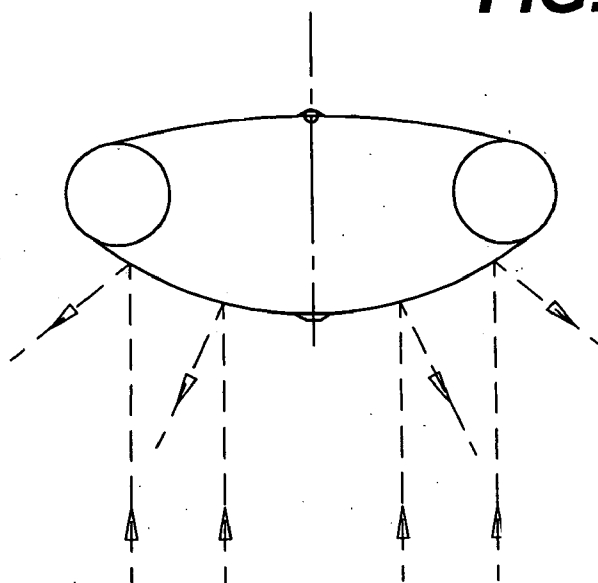

FIG. 3E

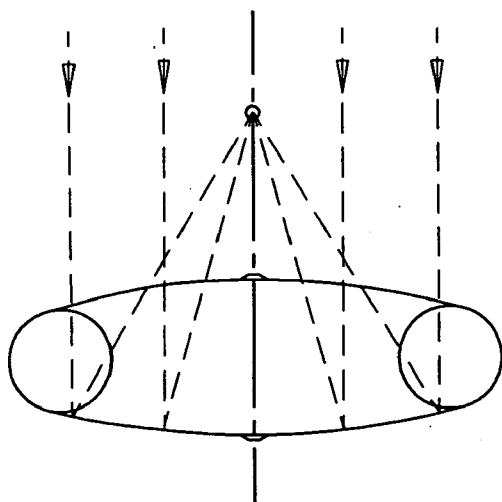

FIG. 3F

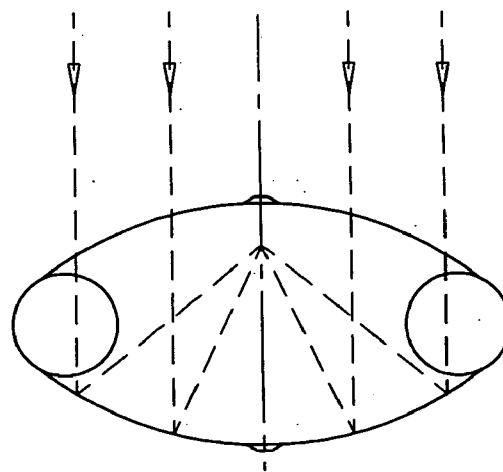

FIG. 3G

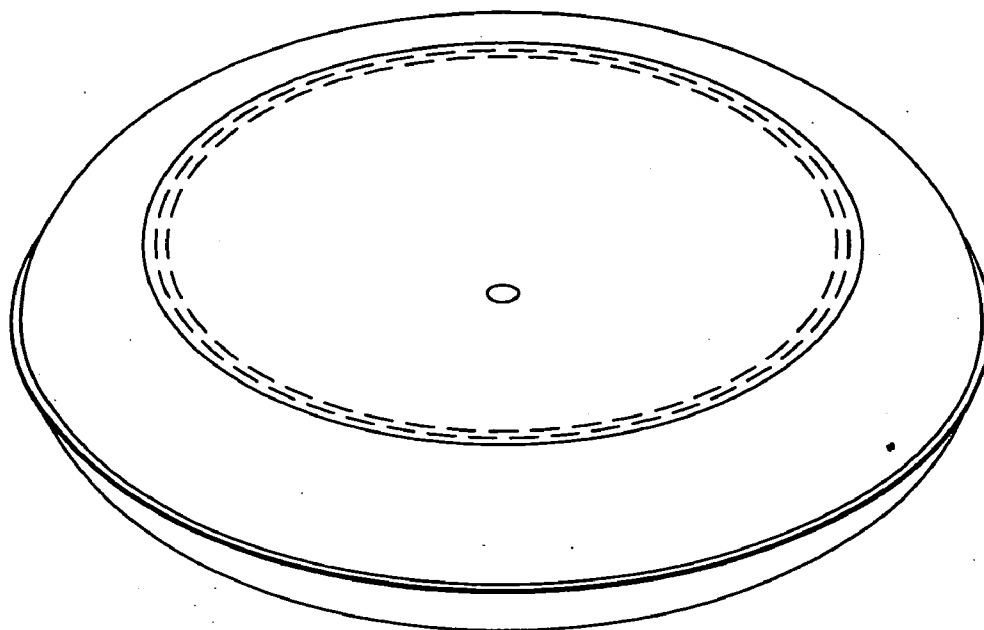

FIG. 5A

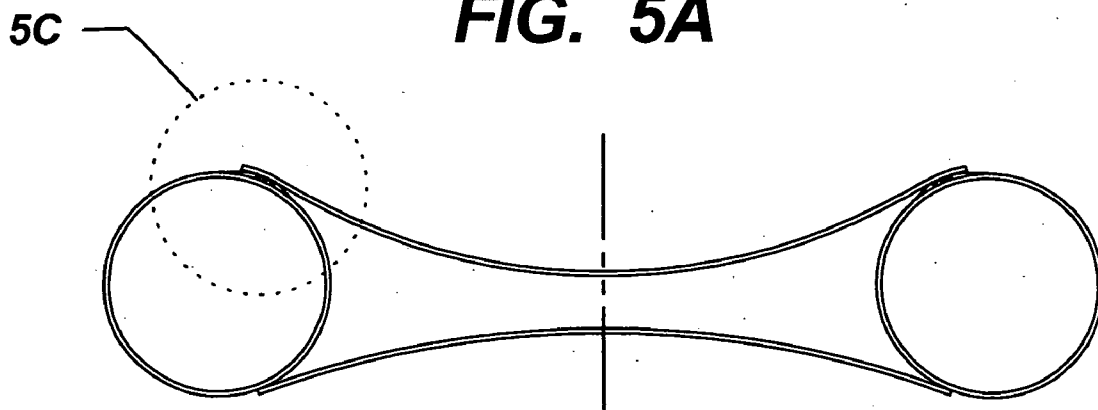

FIG. 5B

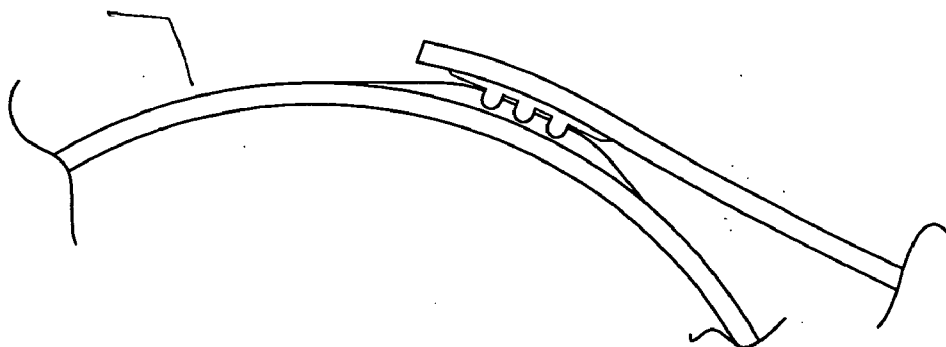

FIG. 5C

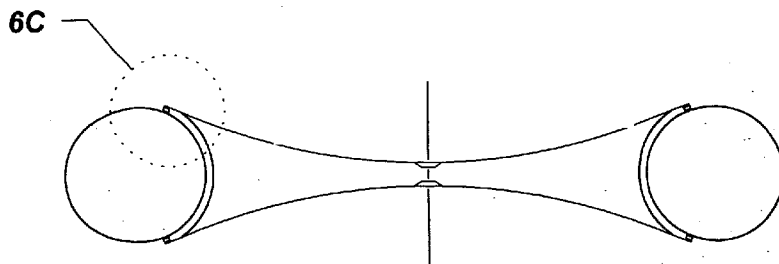

FIG. 6A

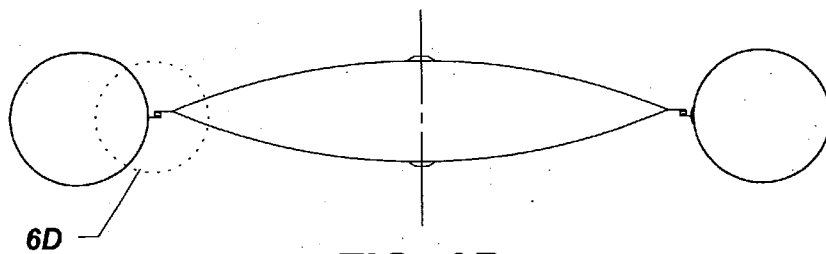

FIG. 6B

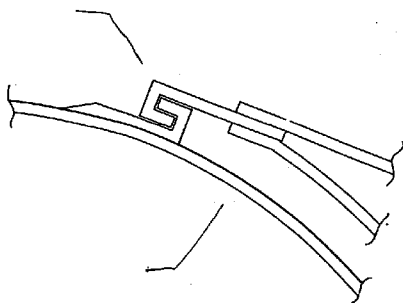

FIG. 6C

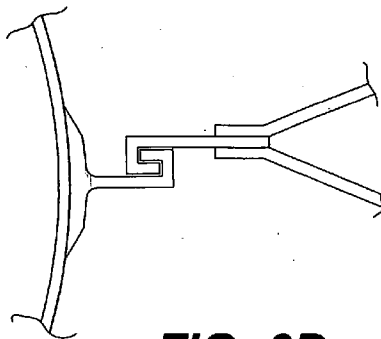

FIG. 6D

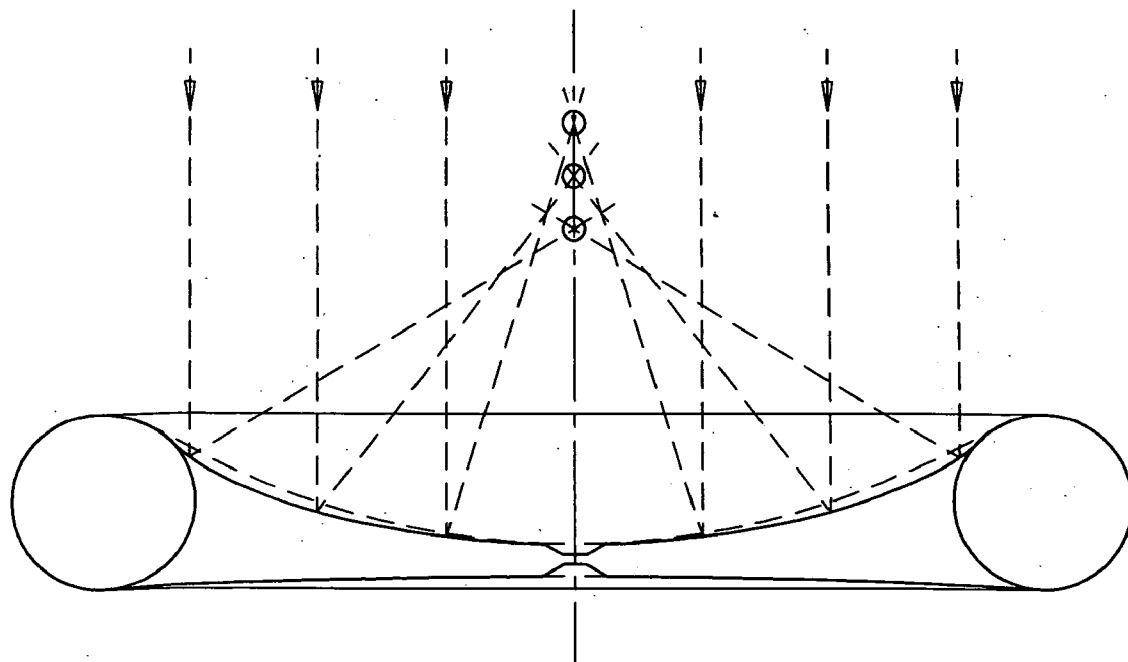

FIG. 7A

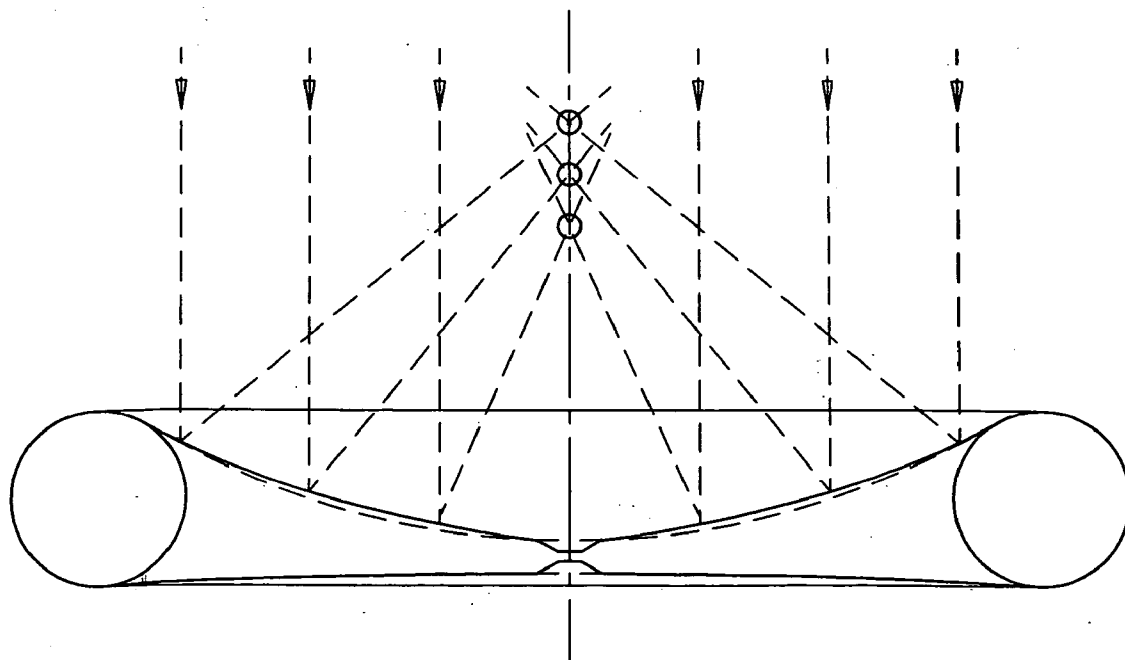

FIG. 7B

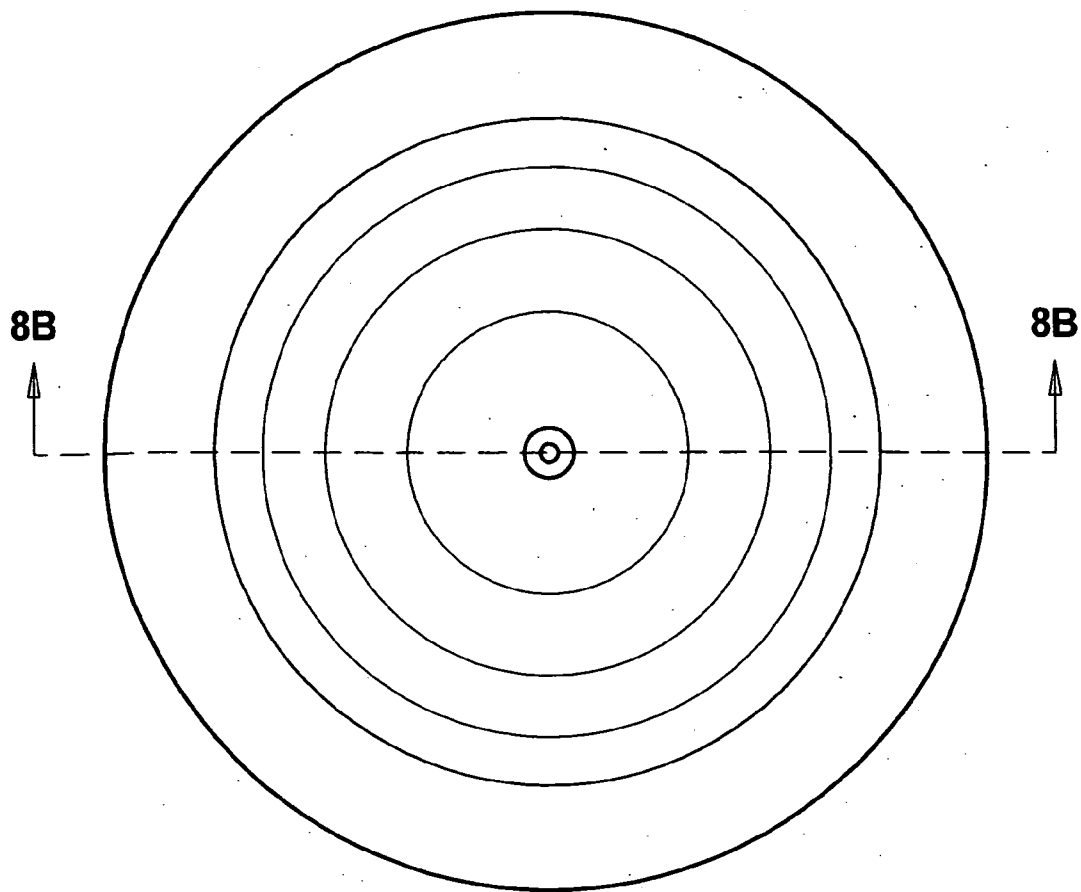

FIG. 8A

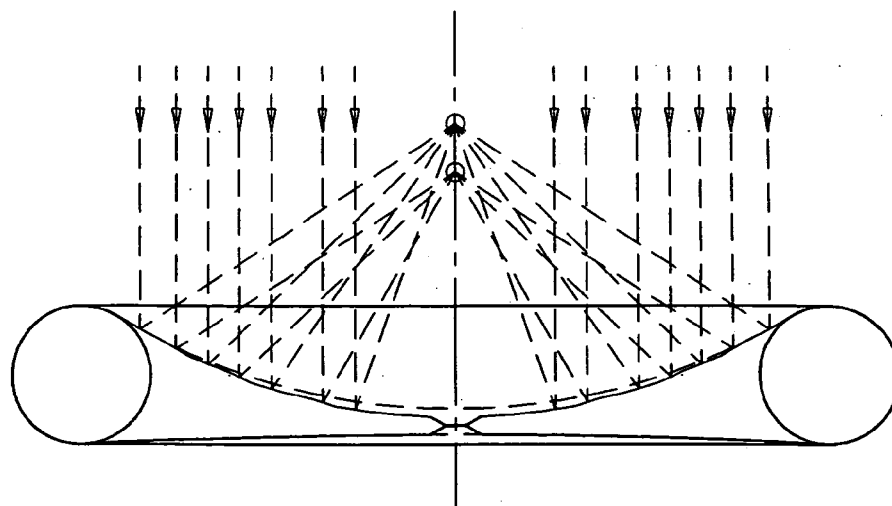

FIG. 8B

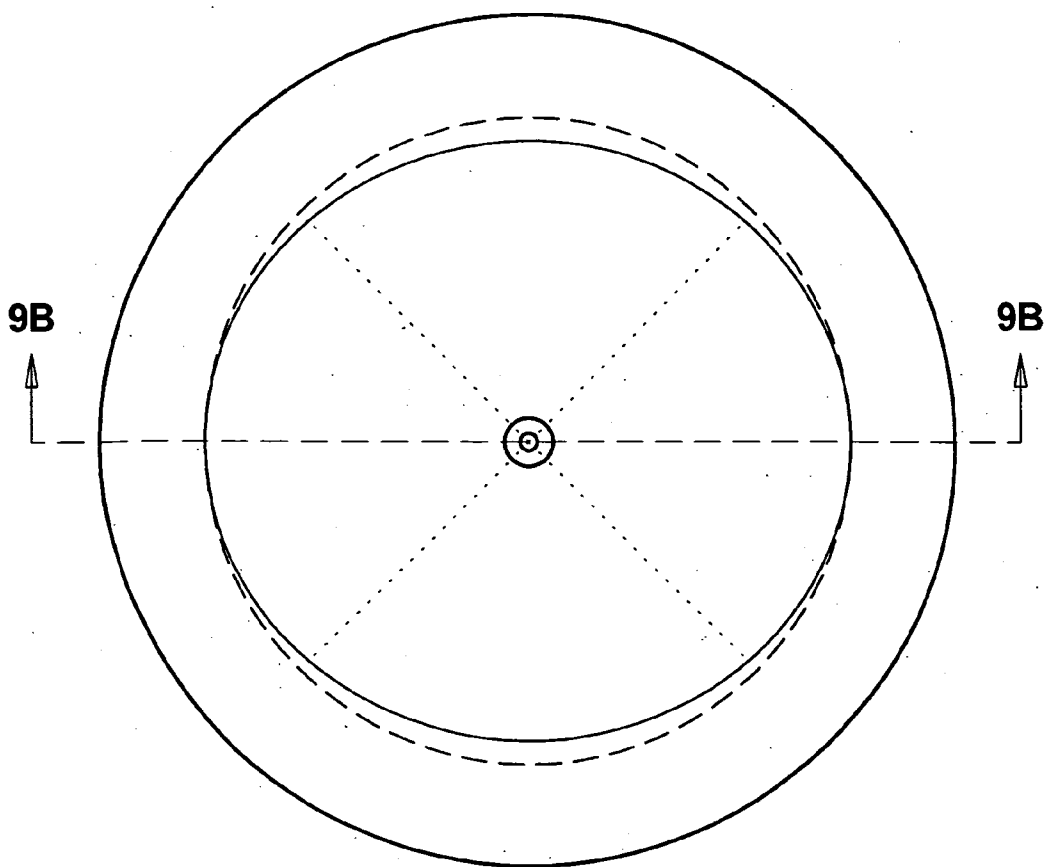

FIG. 9A

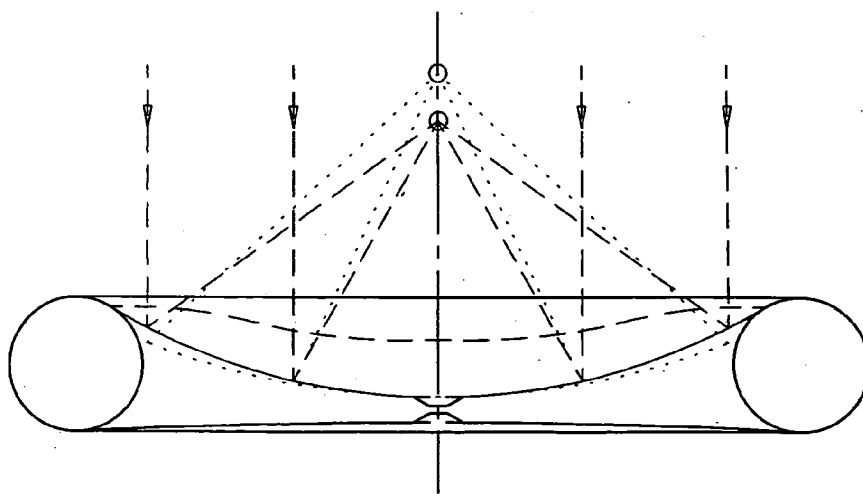

FIG. 9B

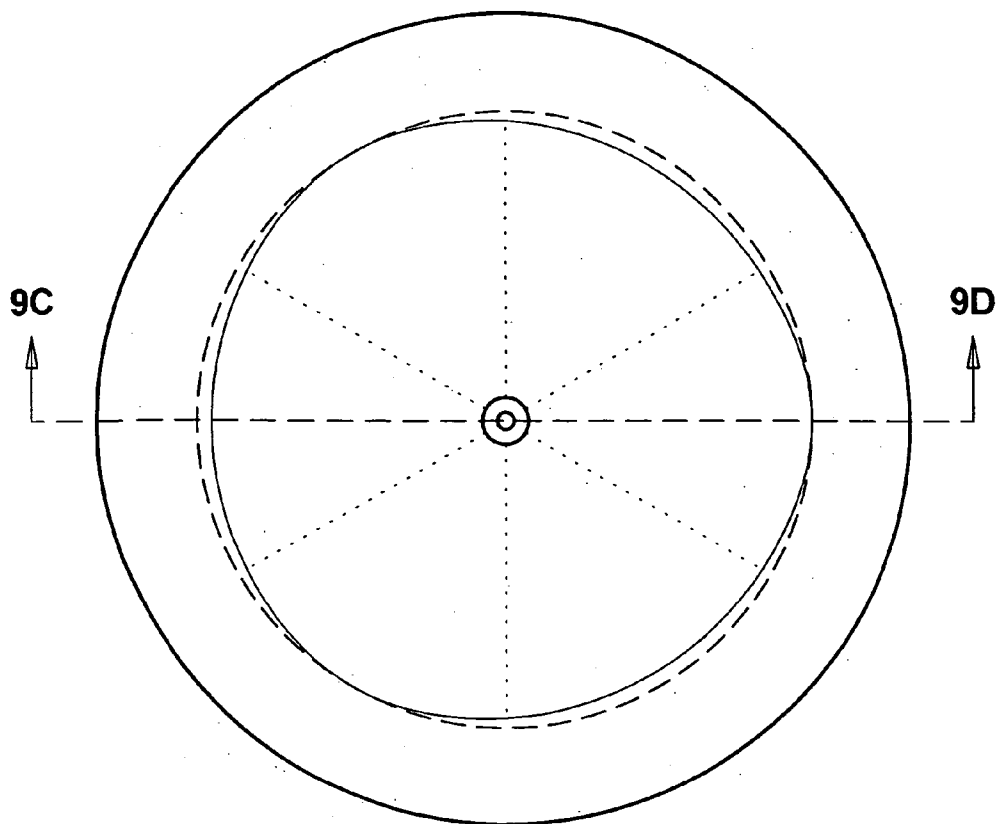

FIG. 9C

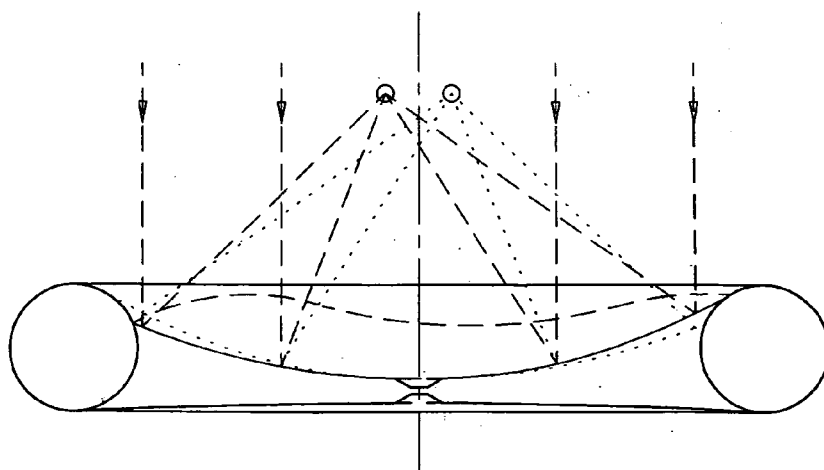

FIG. 9D

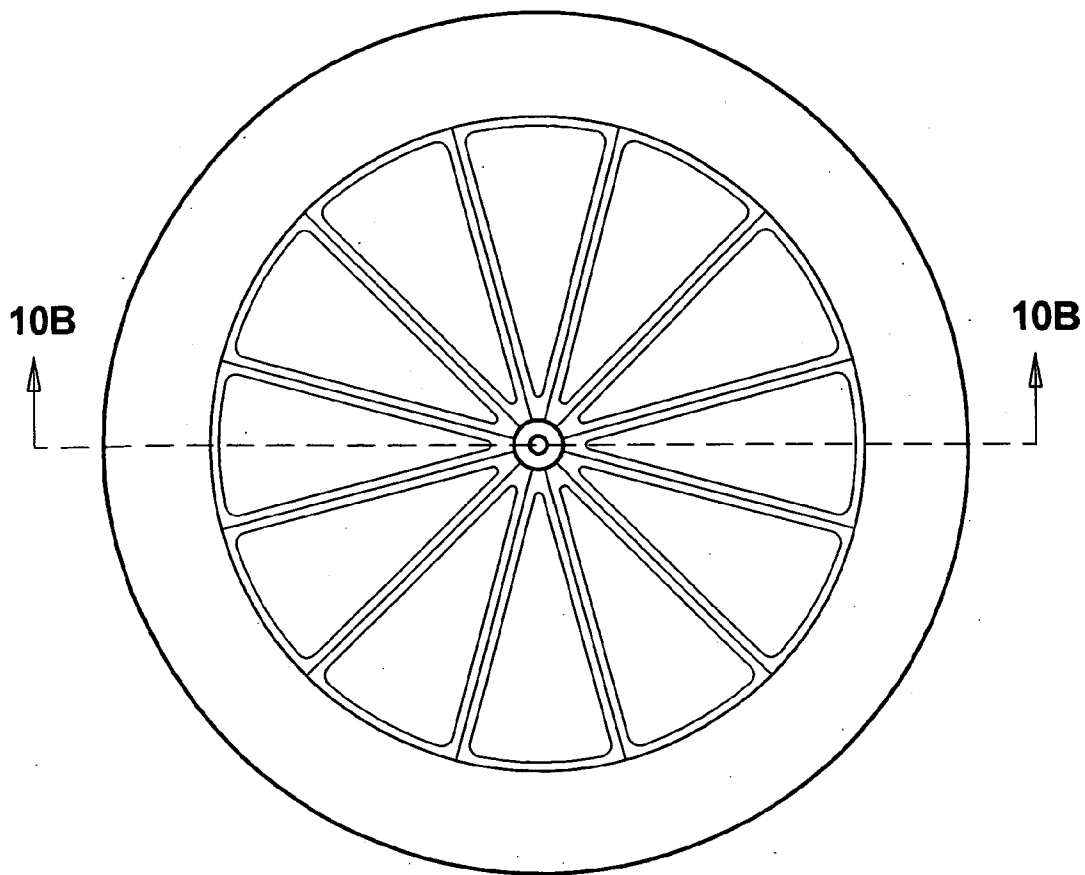

FIG. 10A

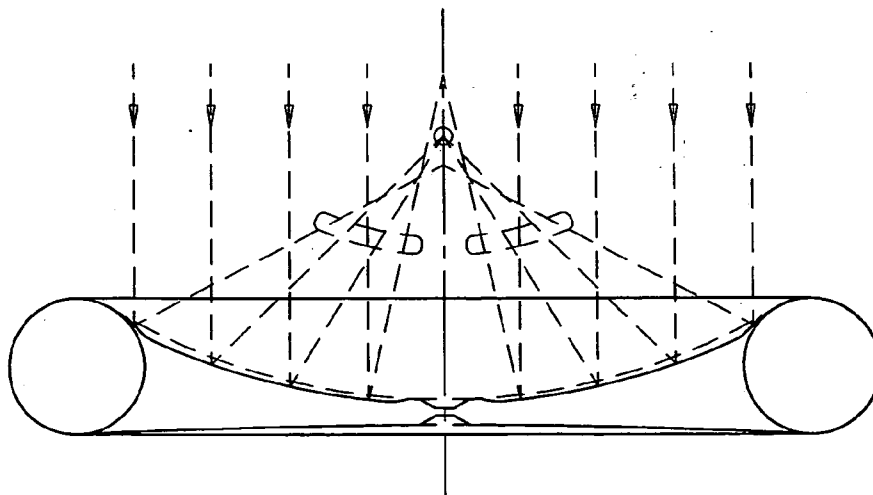

FIG. 10B

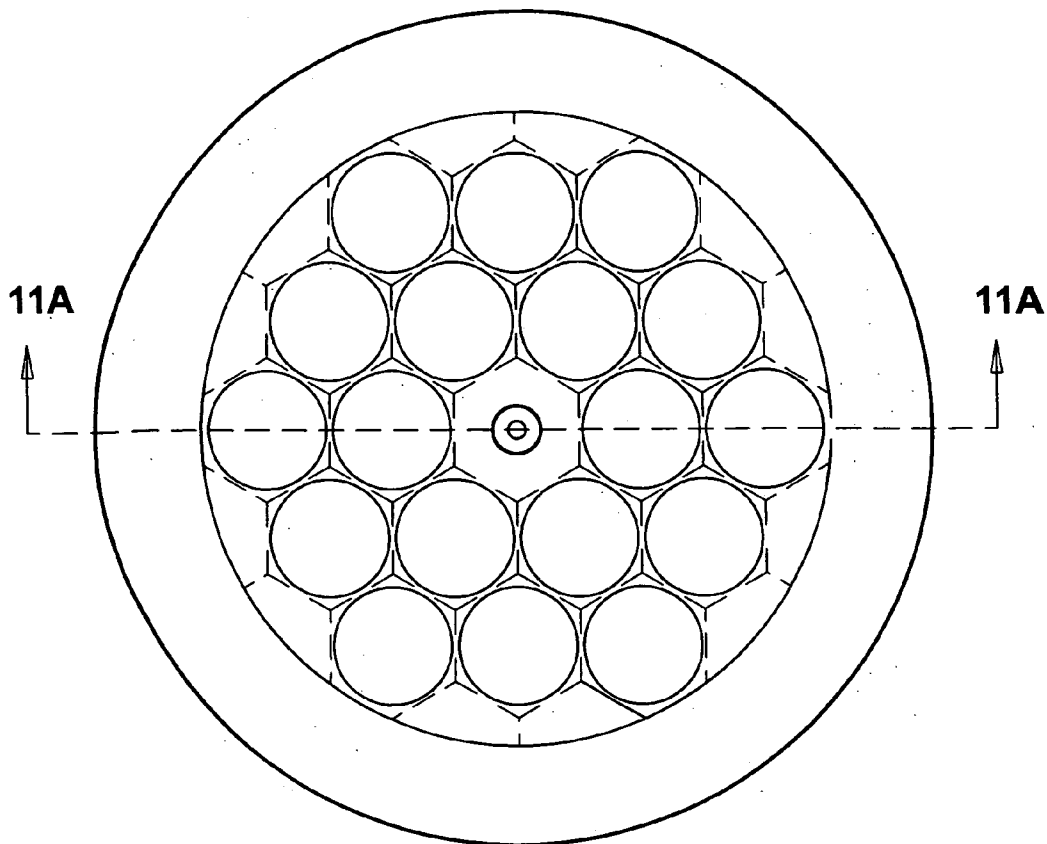

FIG. 11A

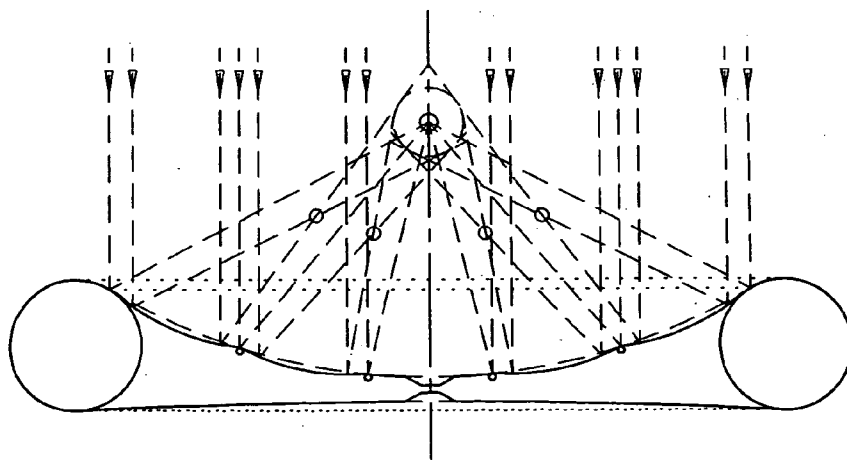

FIG. 11B

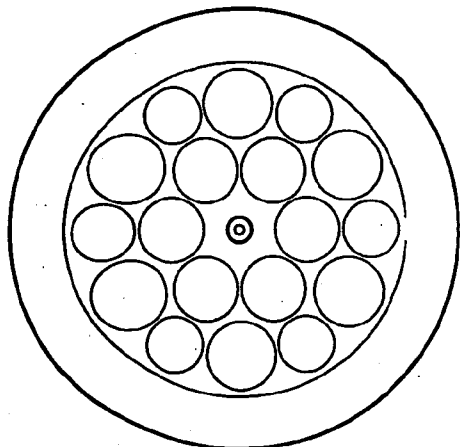

FIG. 11C

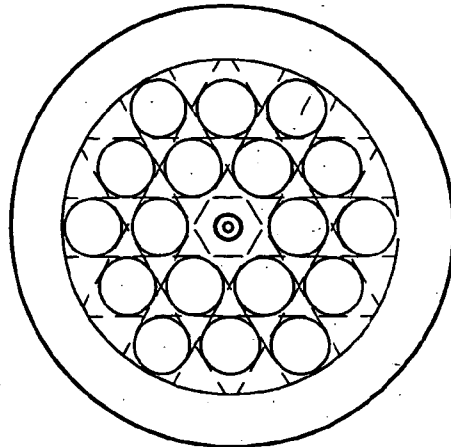

FIG. 11D

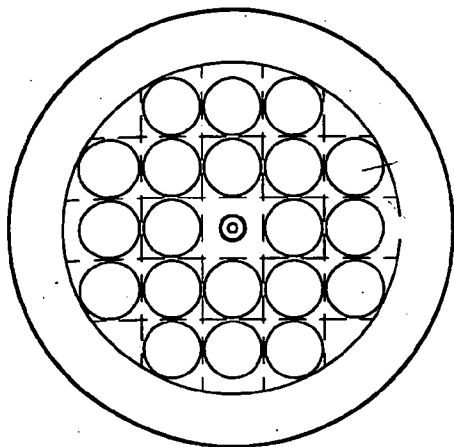

FIG. 11E

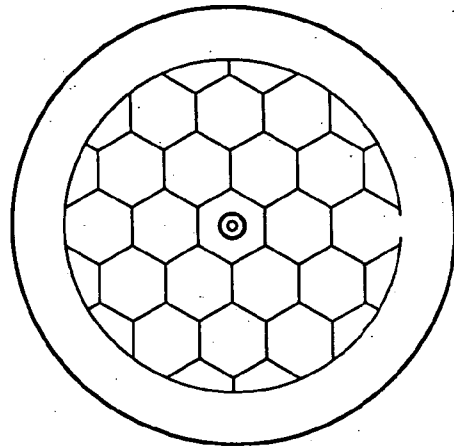

FIG. 11F

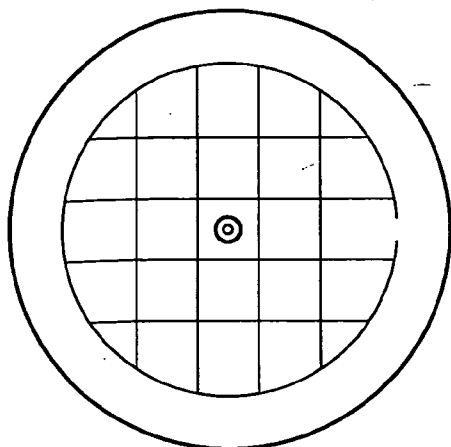

FIG. 11G

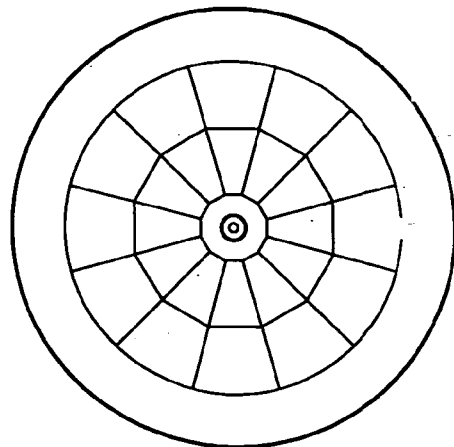

FIG. 11H

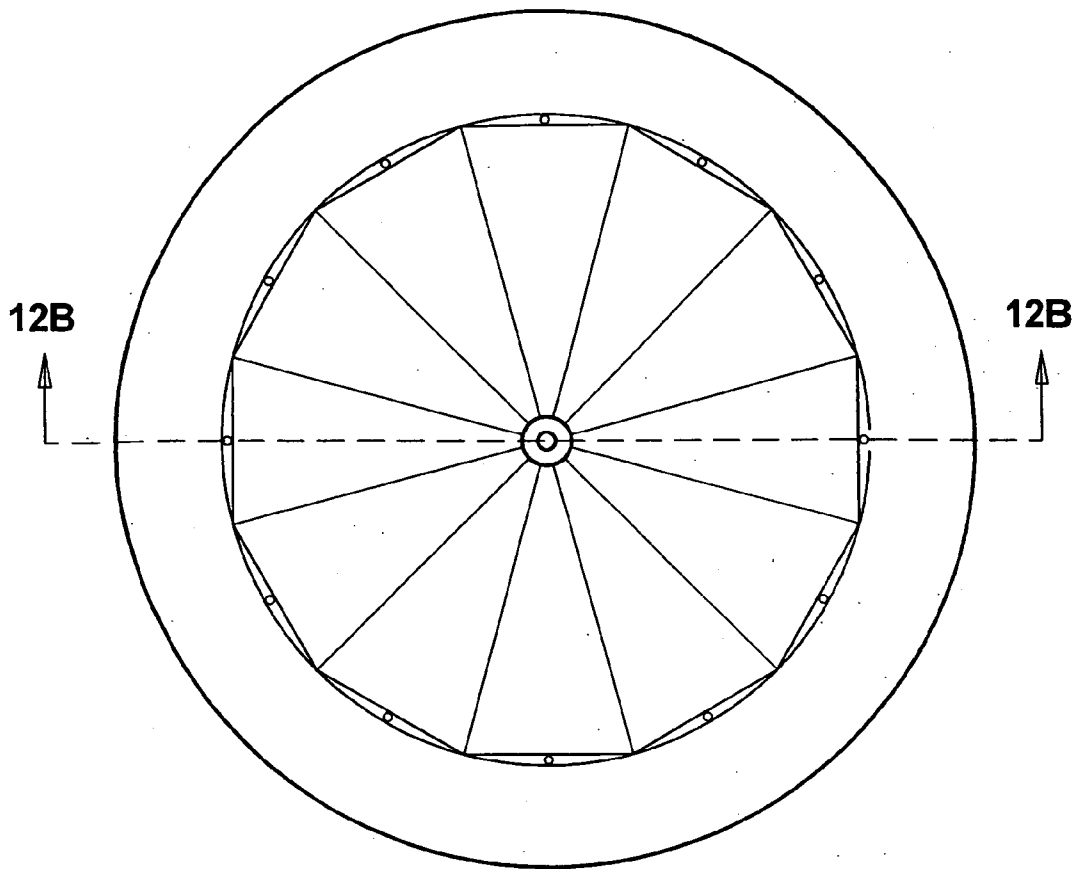

FIG. 12A

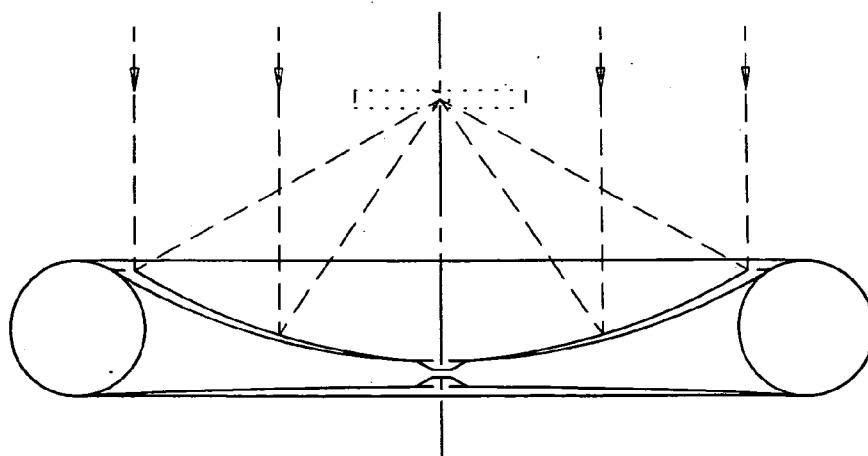

FIG. 12B

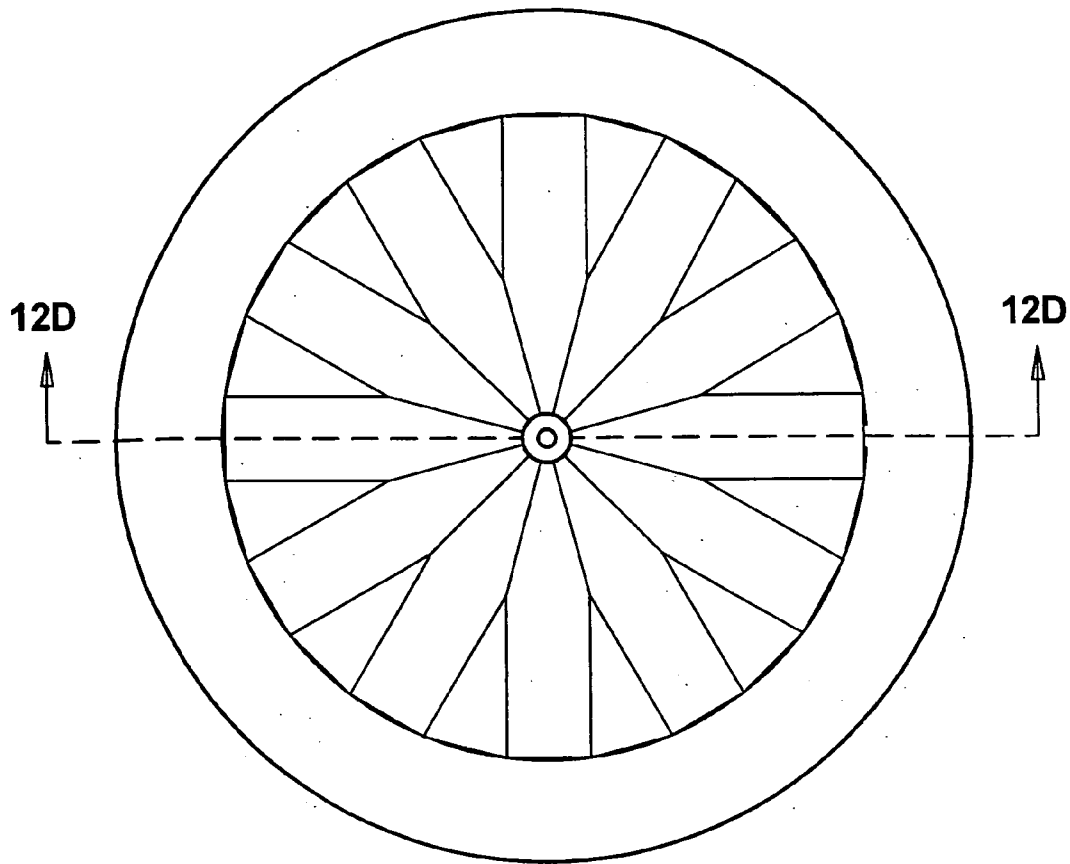

FIG. 12C

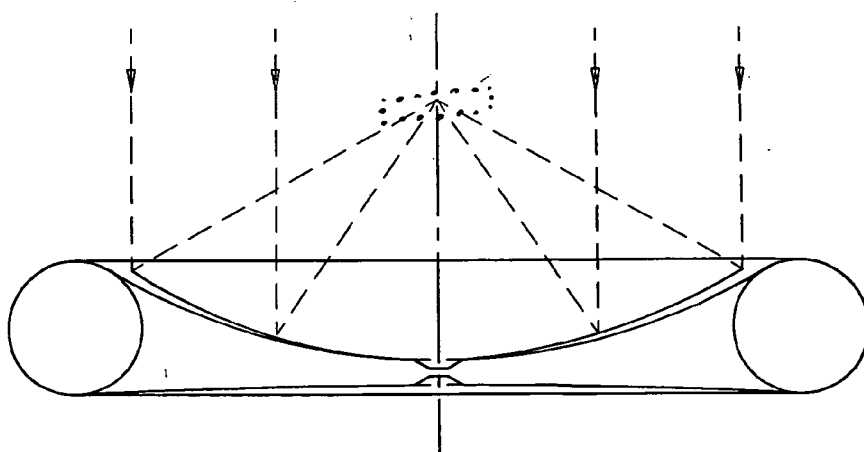

FIG. 12D

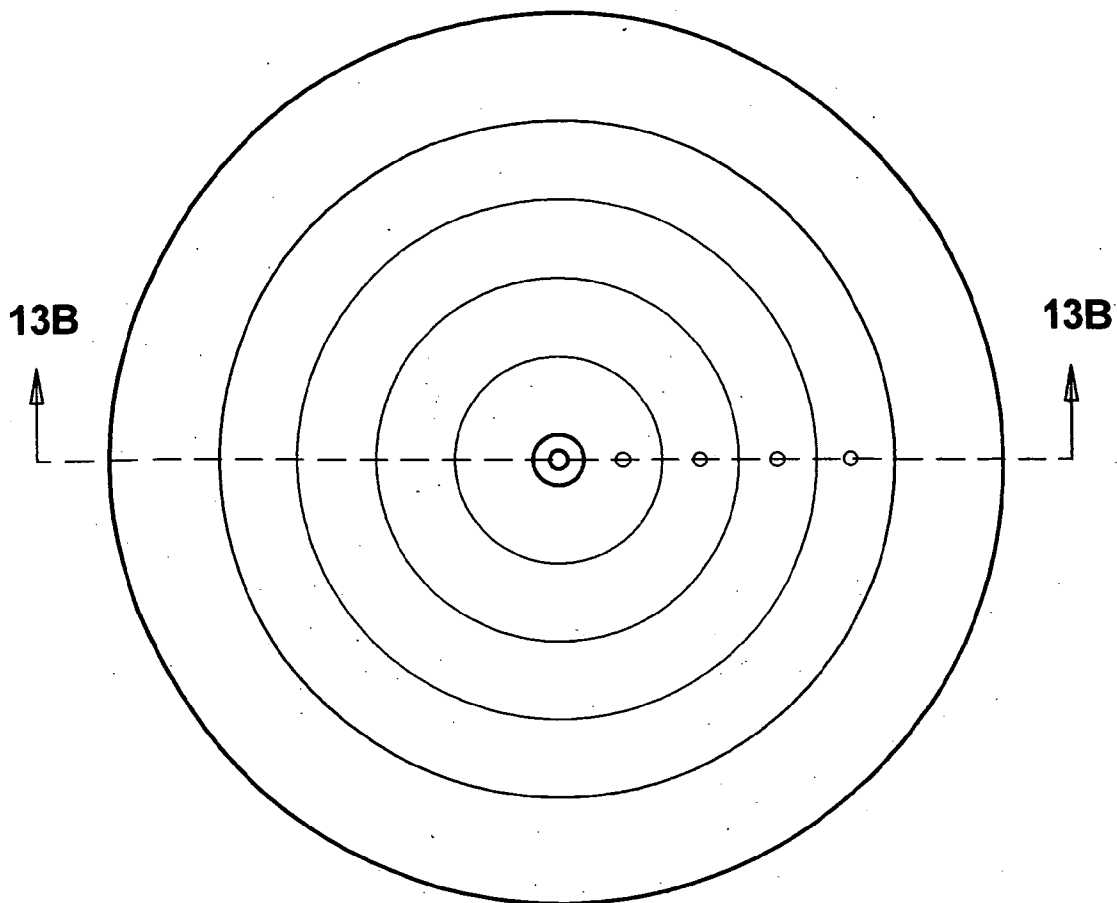

FIG. 13A

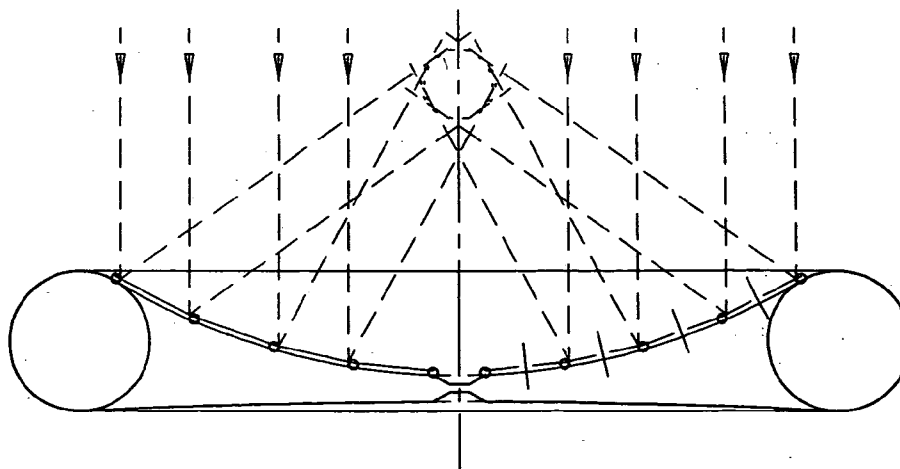

FIG. 13B

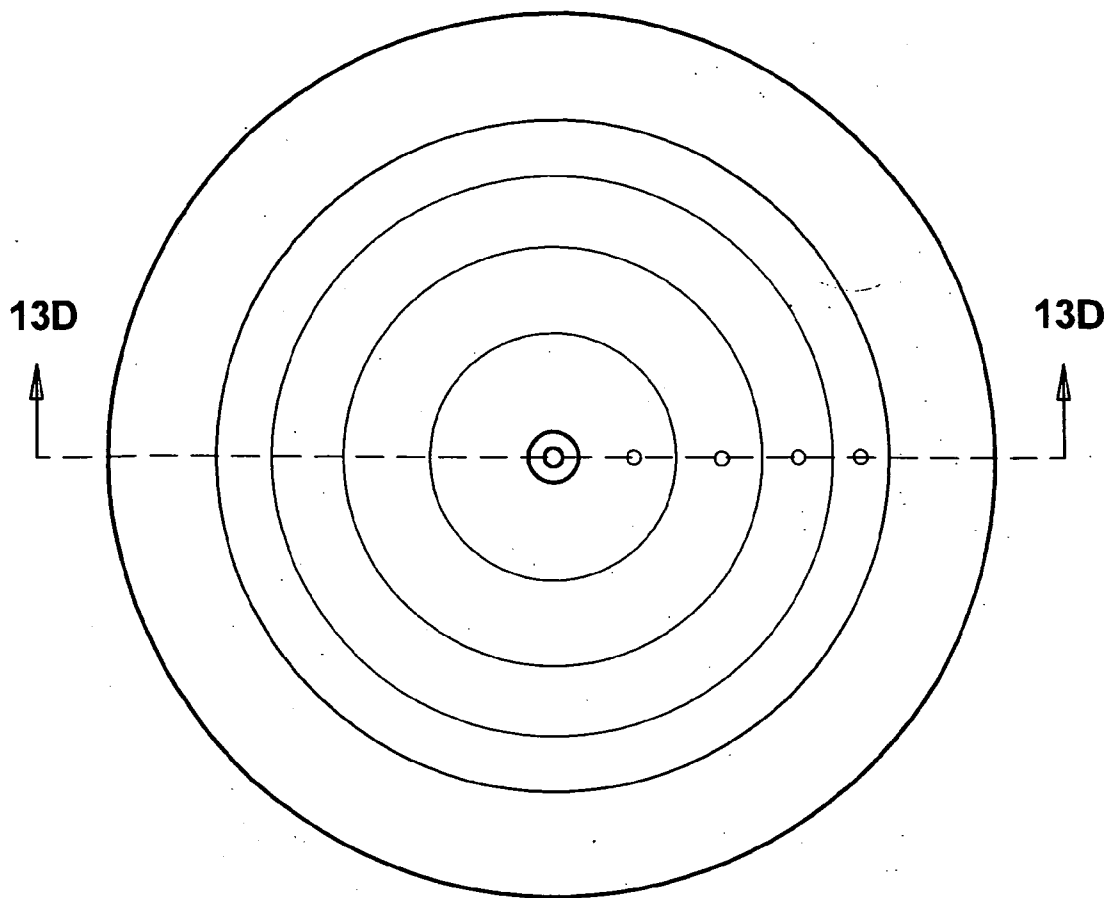

FIG. 13C

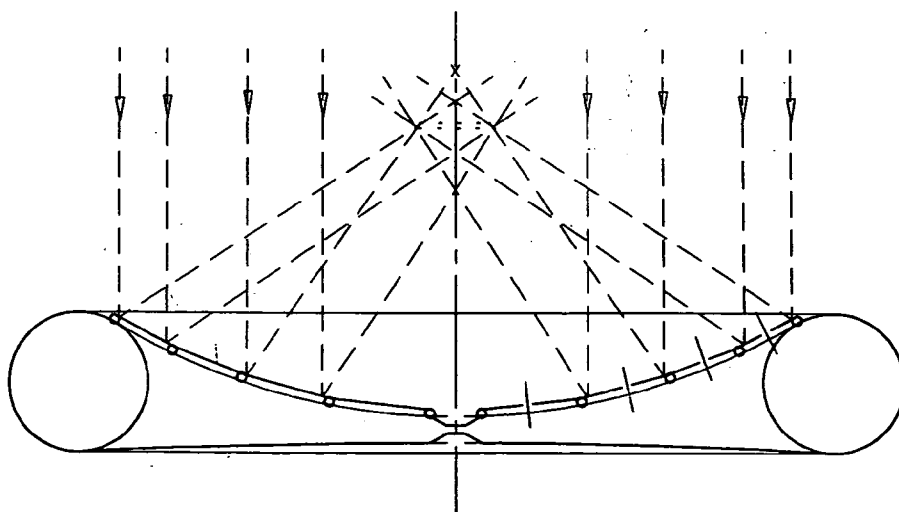

FIG. 13D

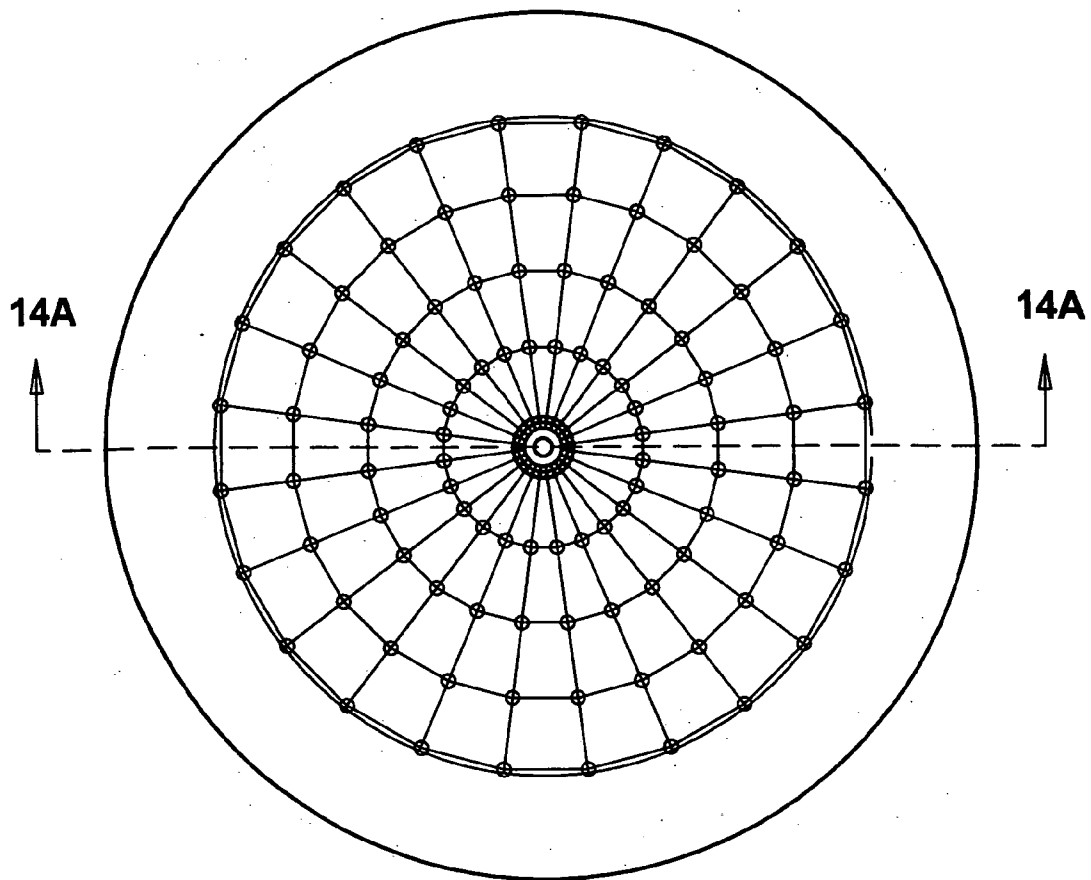

FIG. 14A

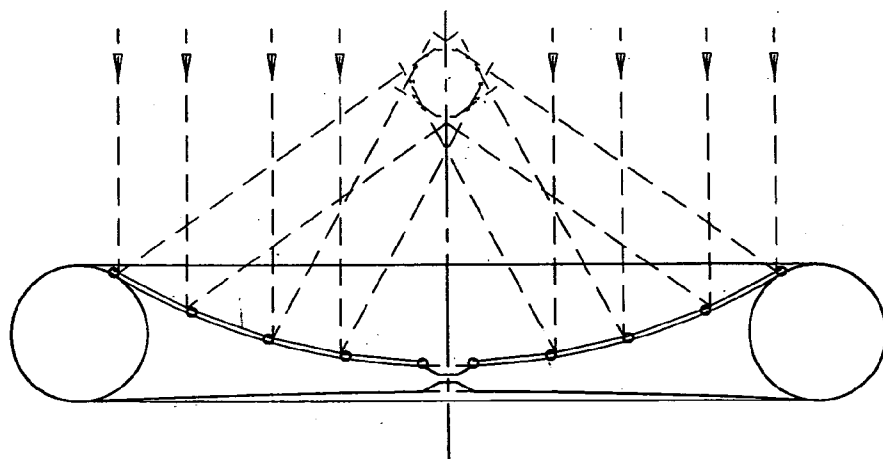

FIG. 14B

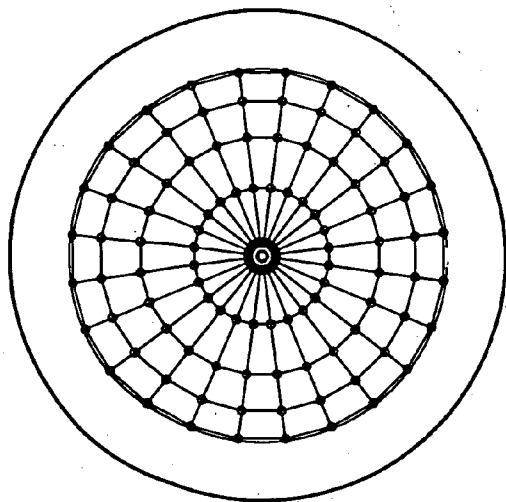

FIG. 14C

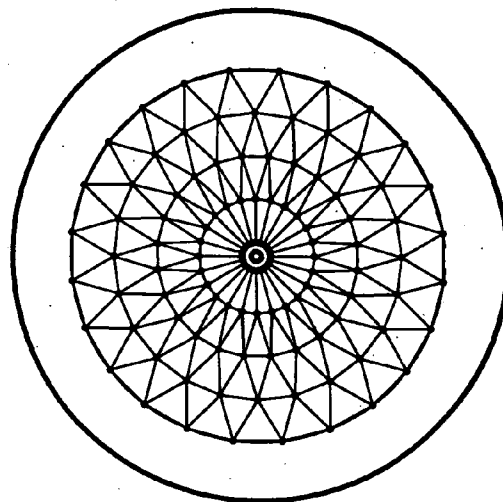

FIG. 14D

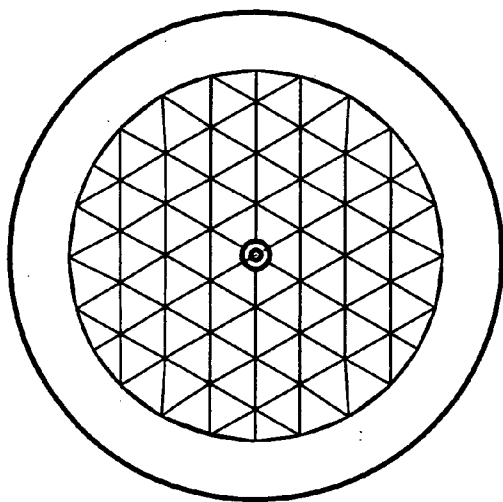

FIG. 14E

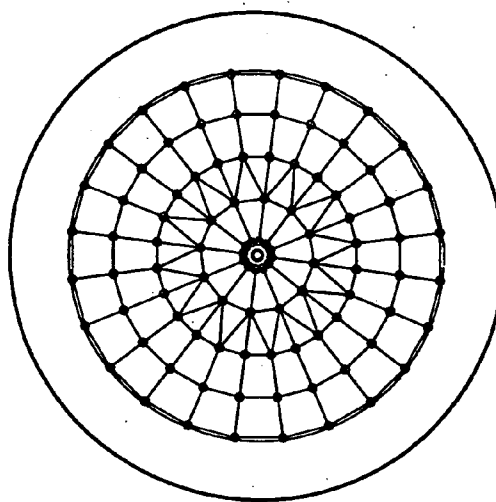

FIG. 14F

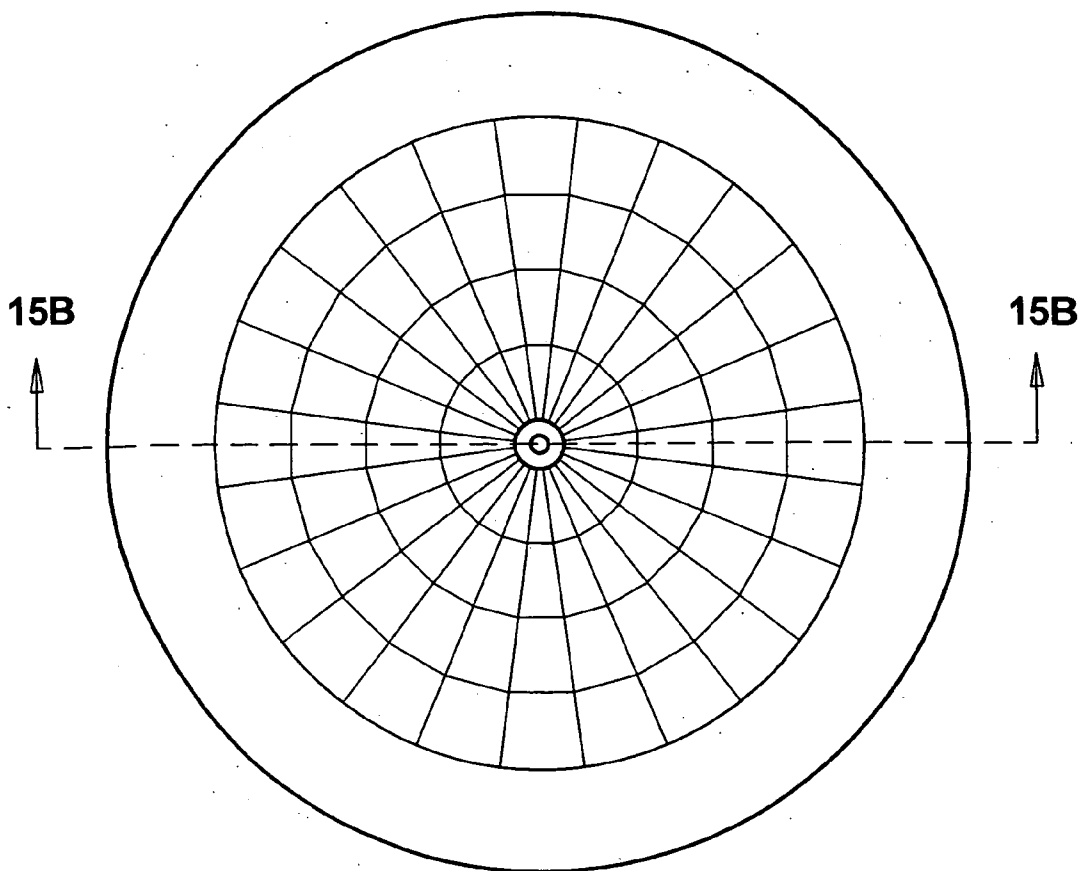

FIG. 15A

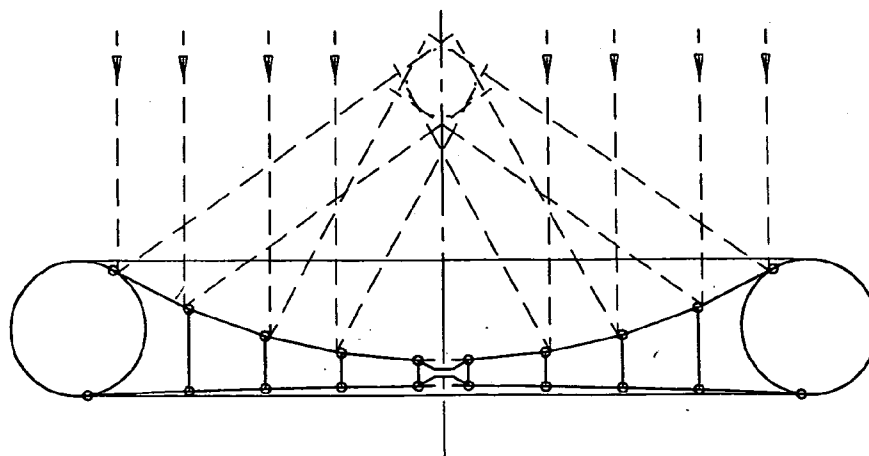

FIG. 15B

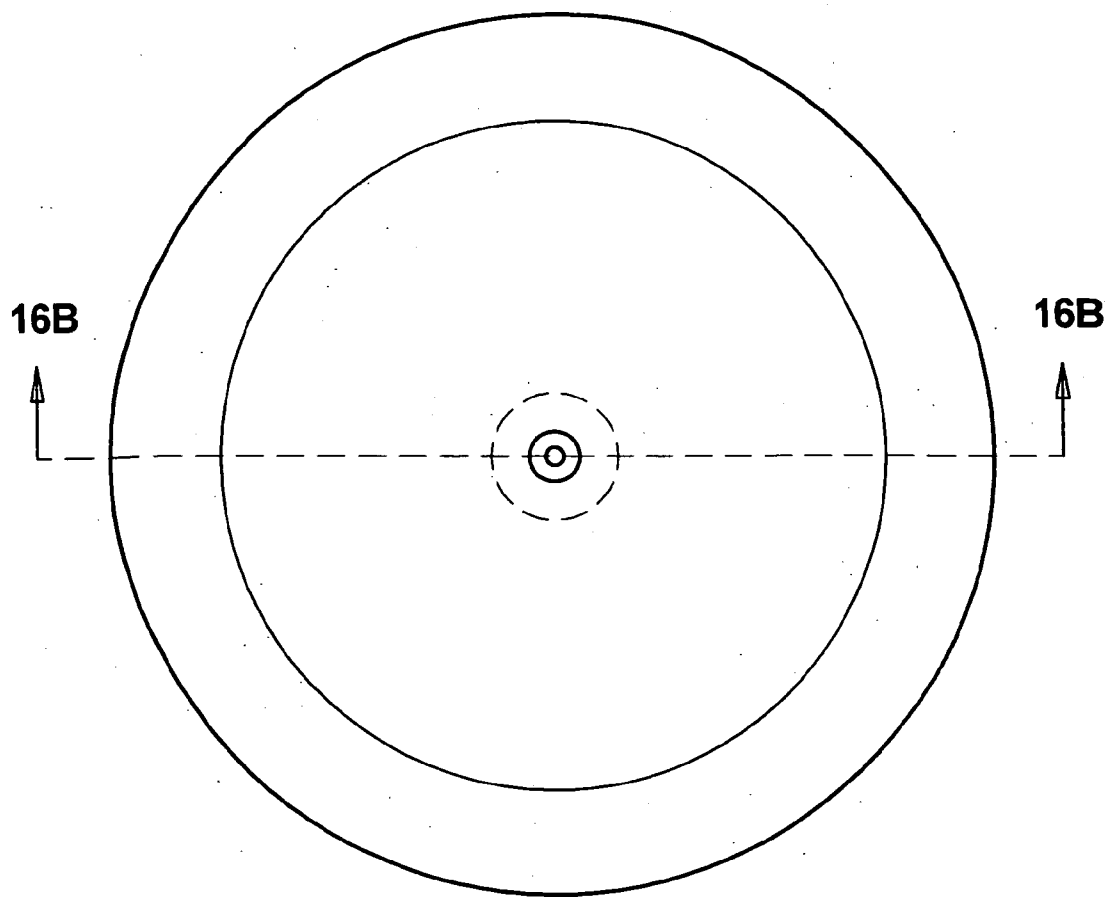

FIG. 16A

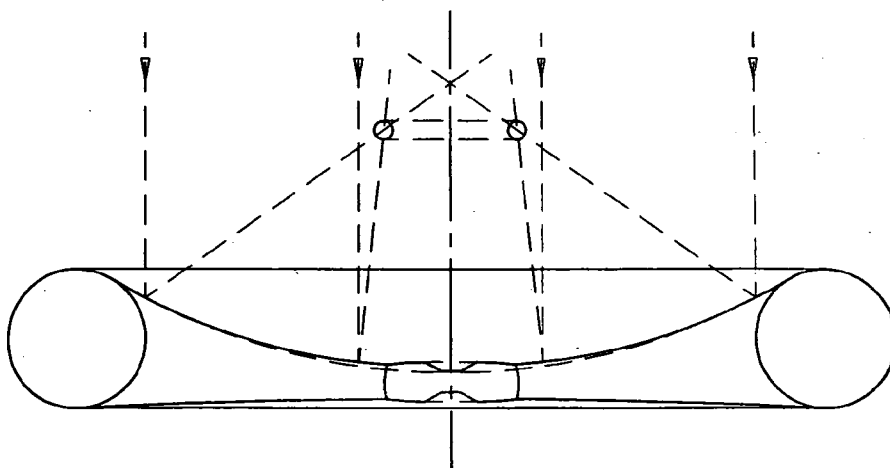

FIG. 16B

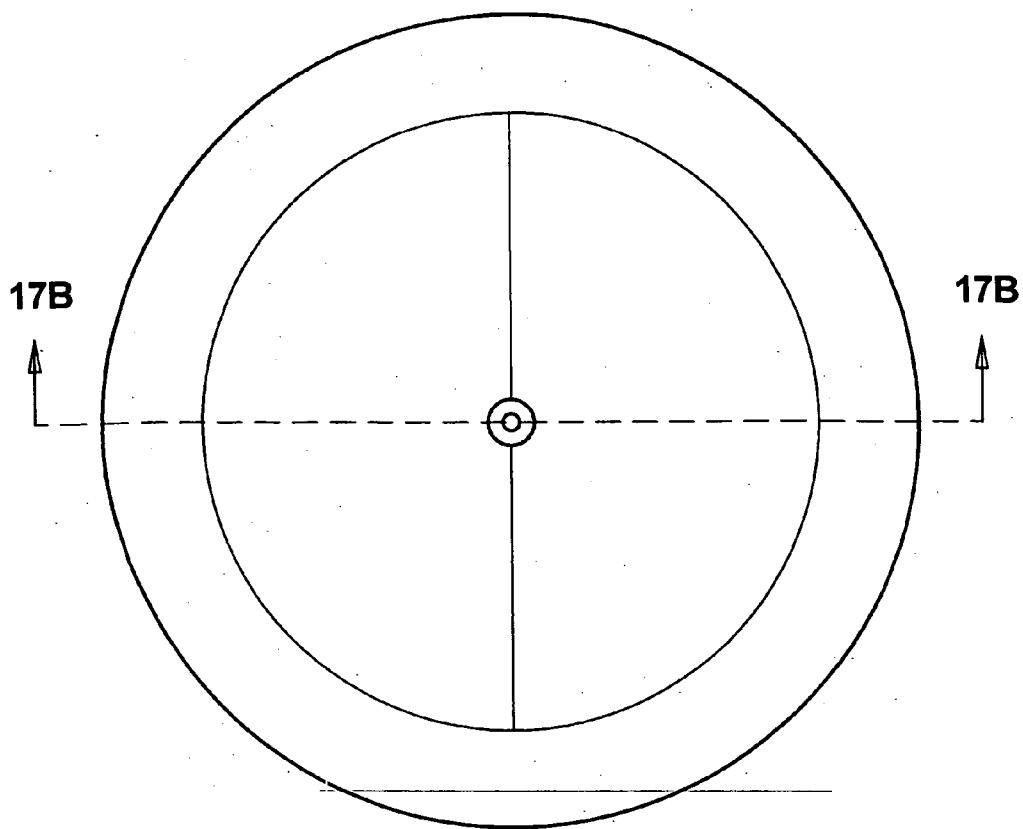

FIG. 17A

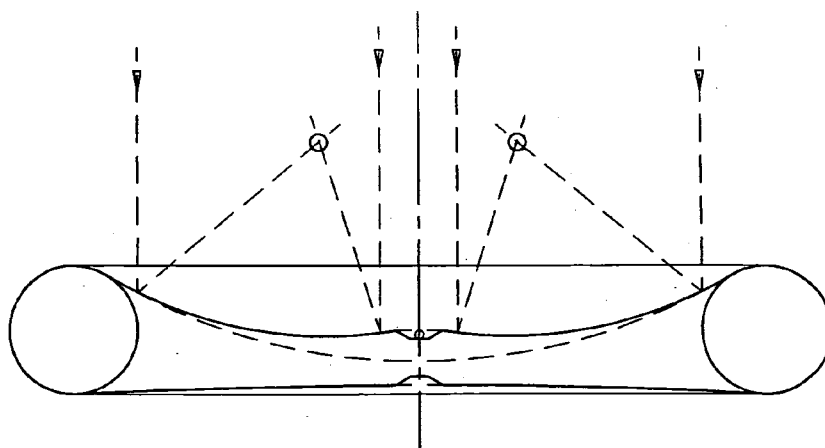

FIG. 17B

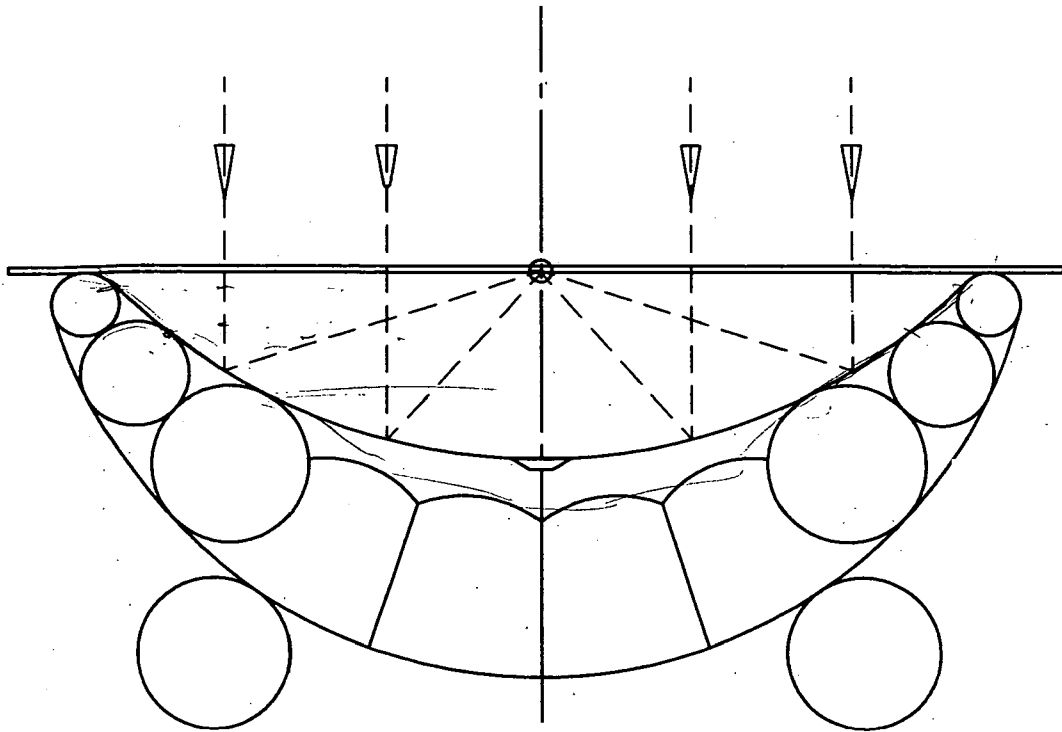

FIG 26

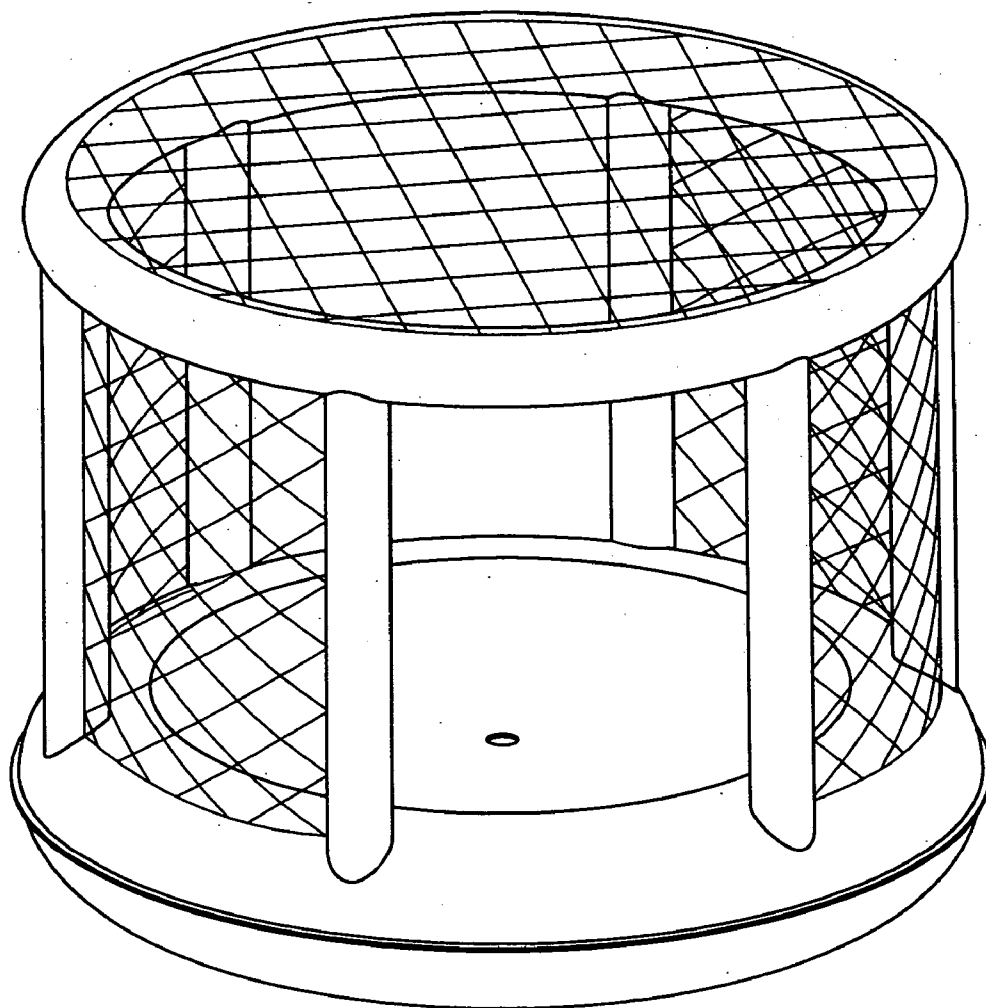

FIG. 27A

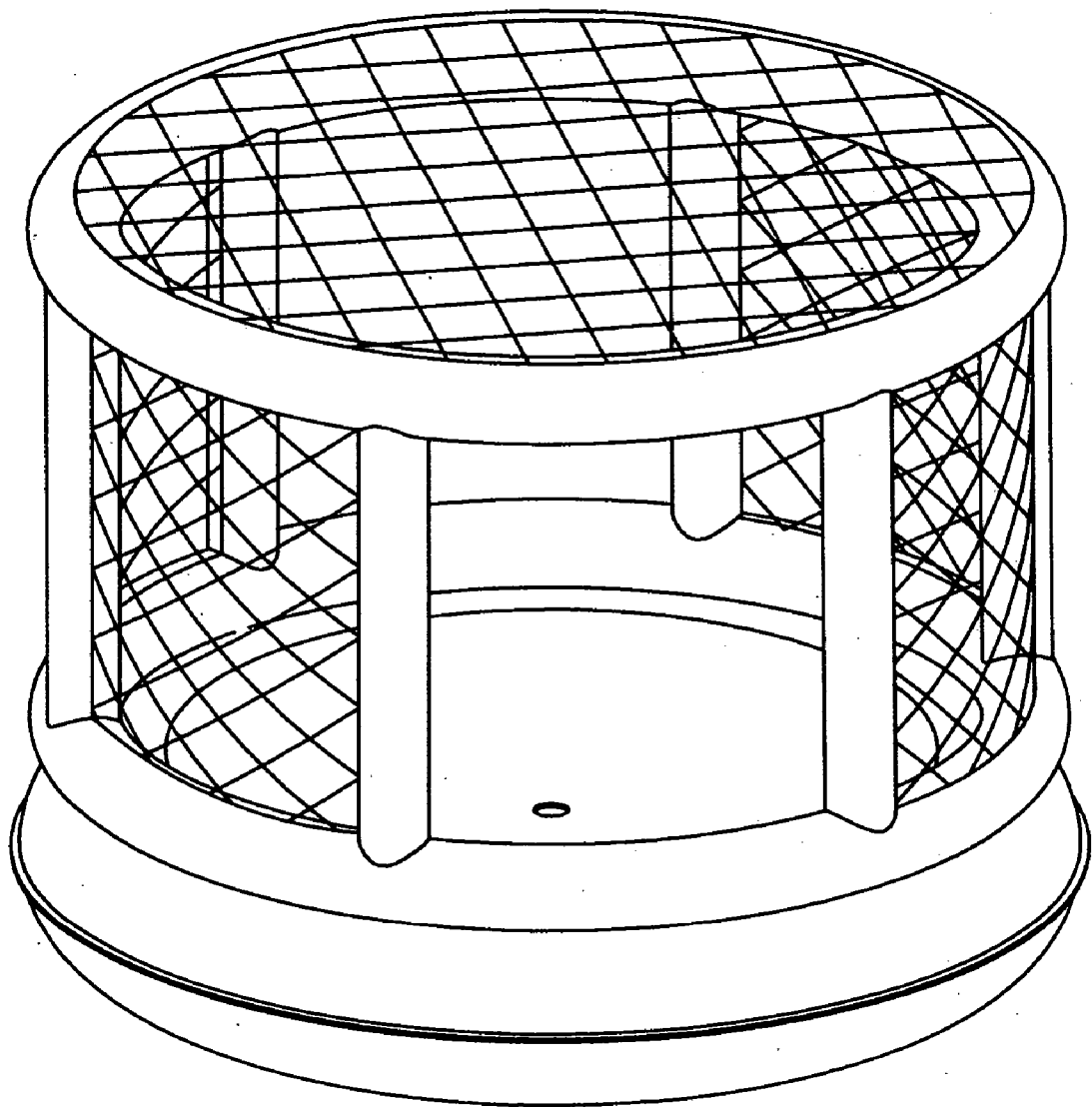

FIG. 27B

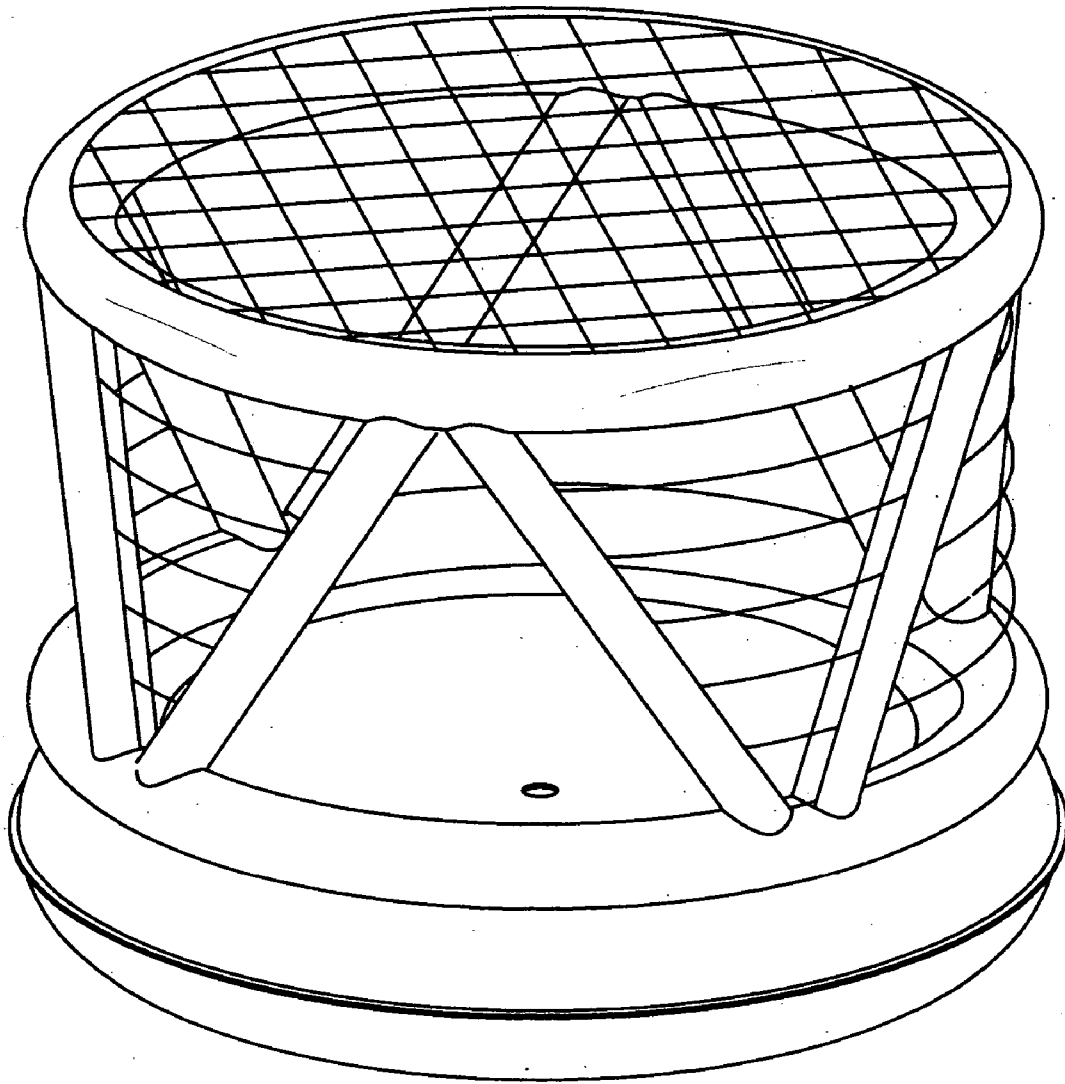

FIG. 27C

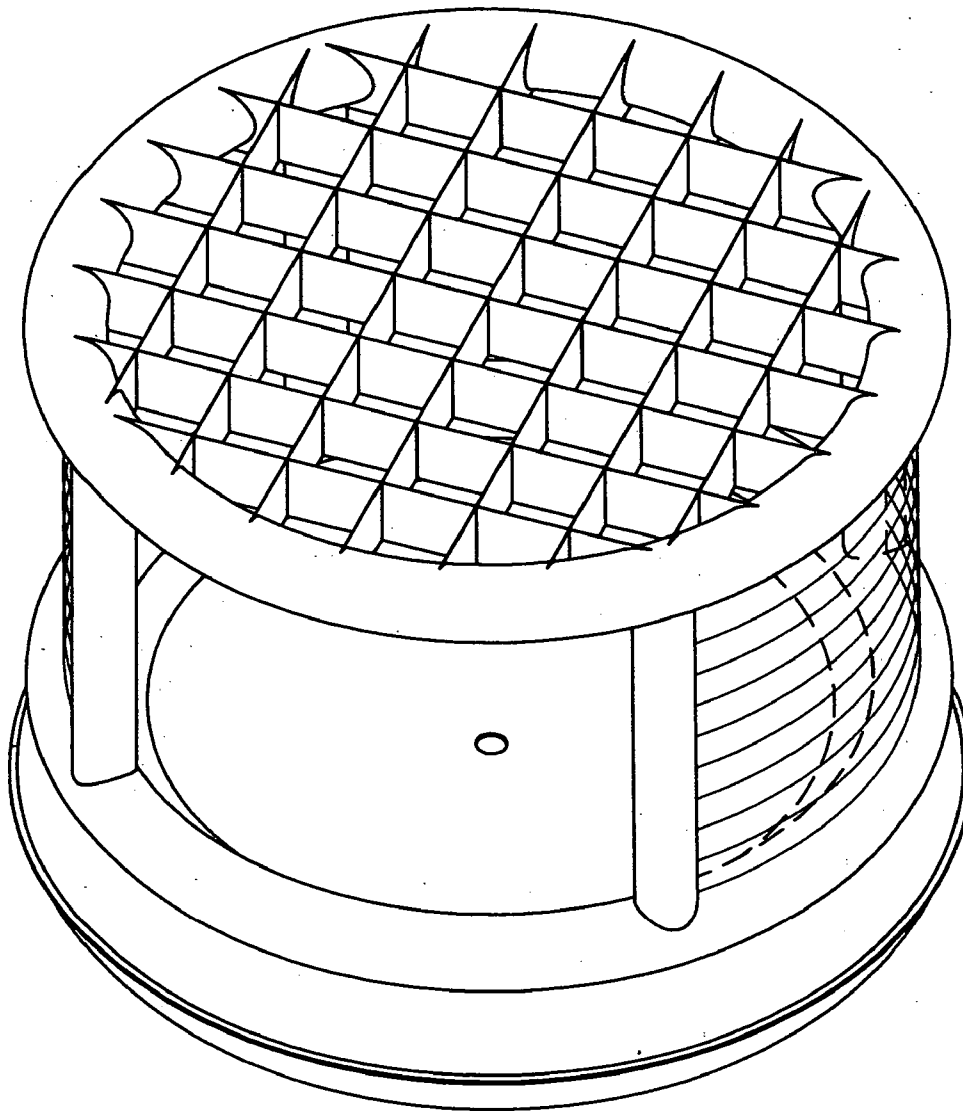

FIG. 27 D

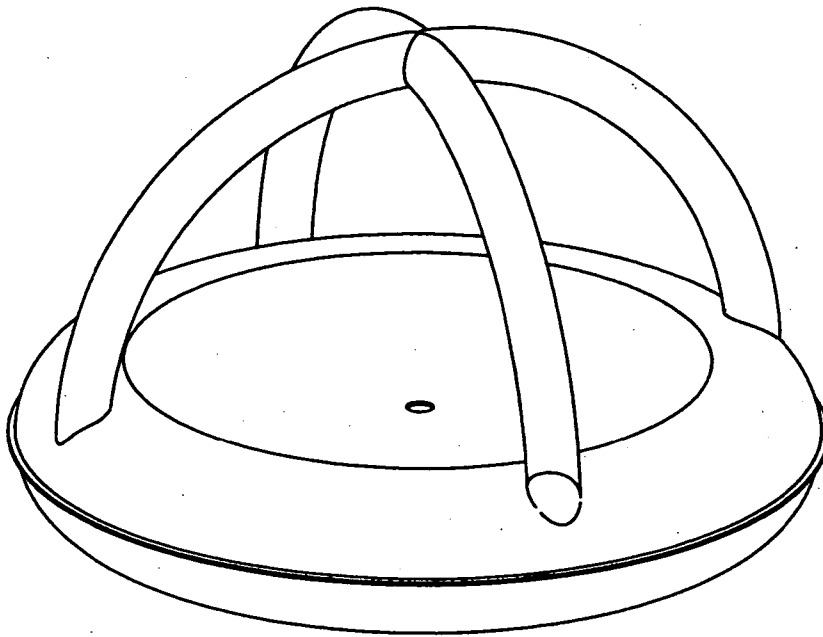

FIG. 29A

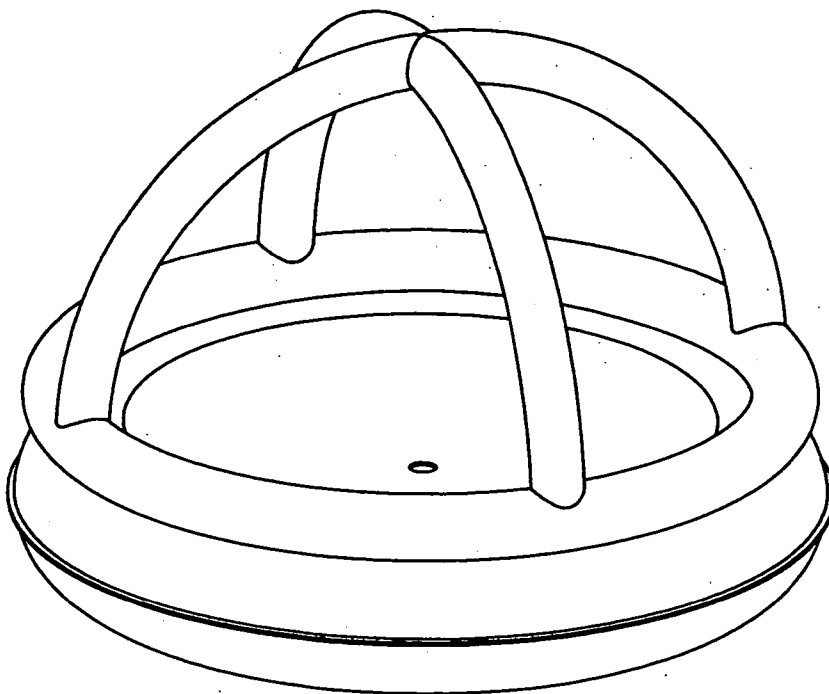

FIG. 29B

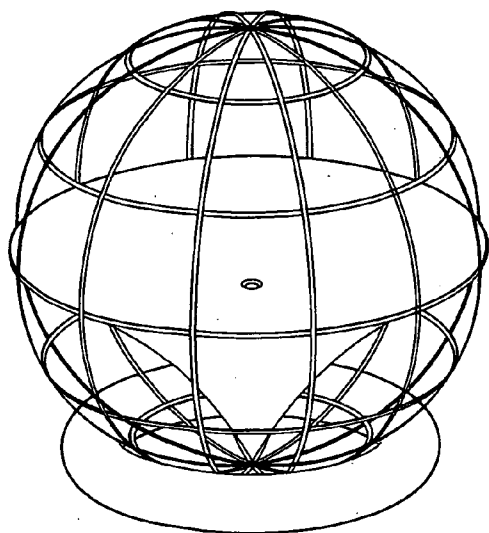

FIG. 31A

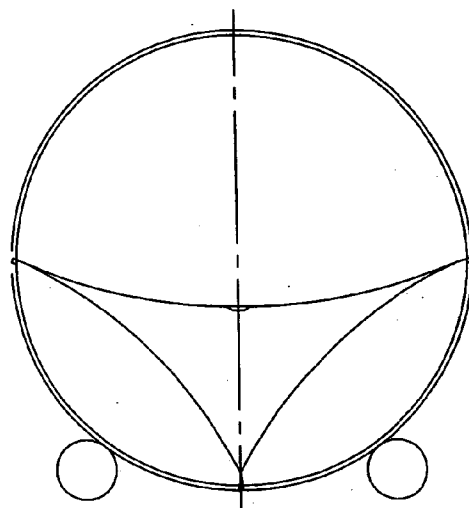

FIG. 31B

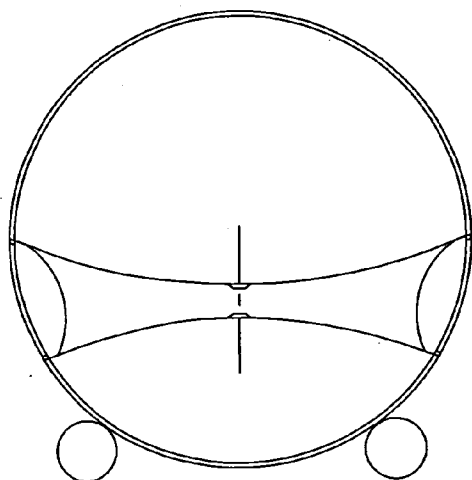

FIG. 31C

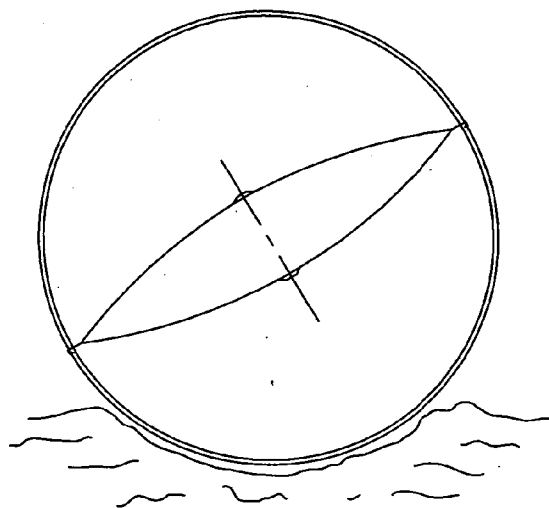

FIG. 31D

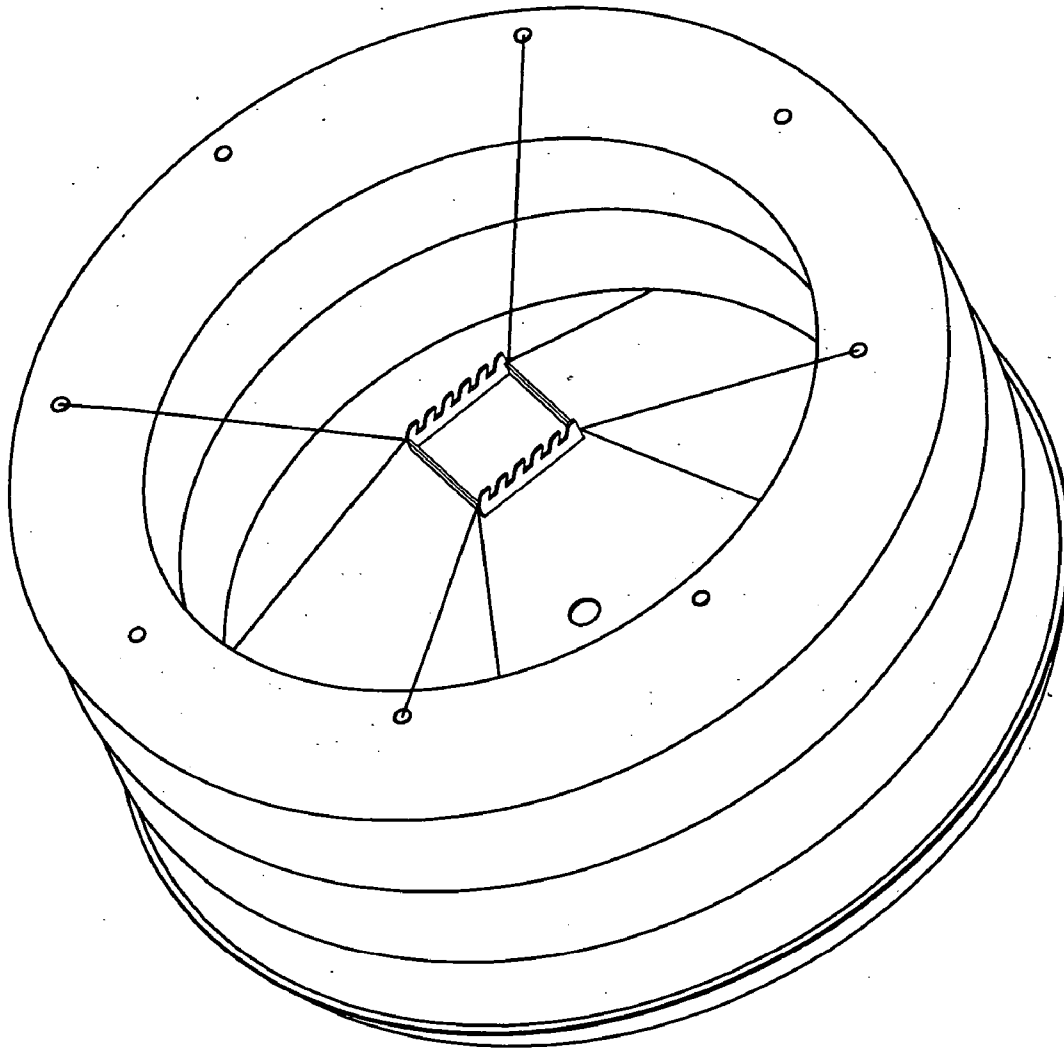

FIG. 32 A

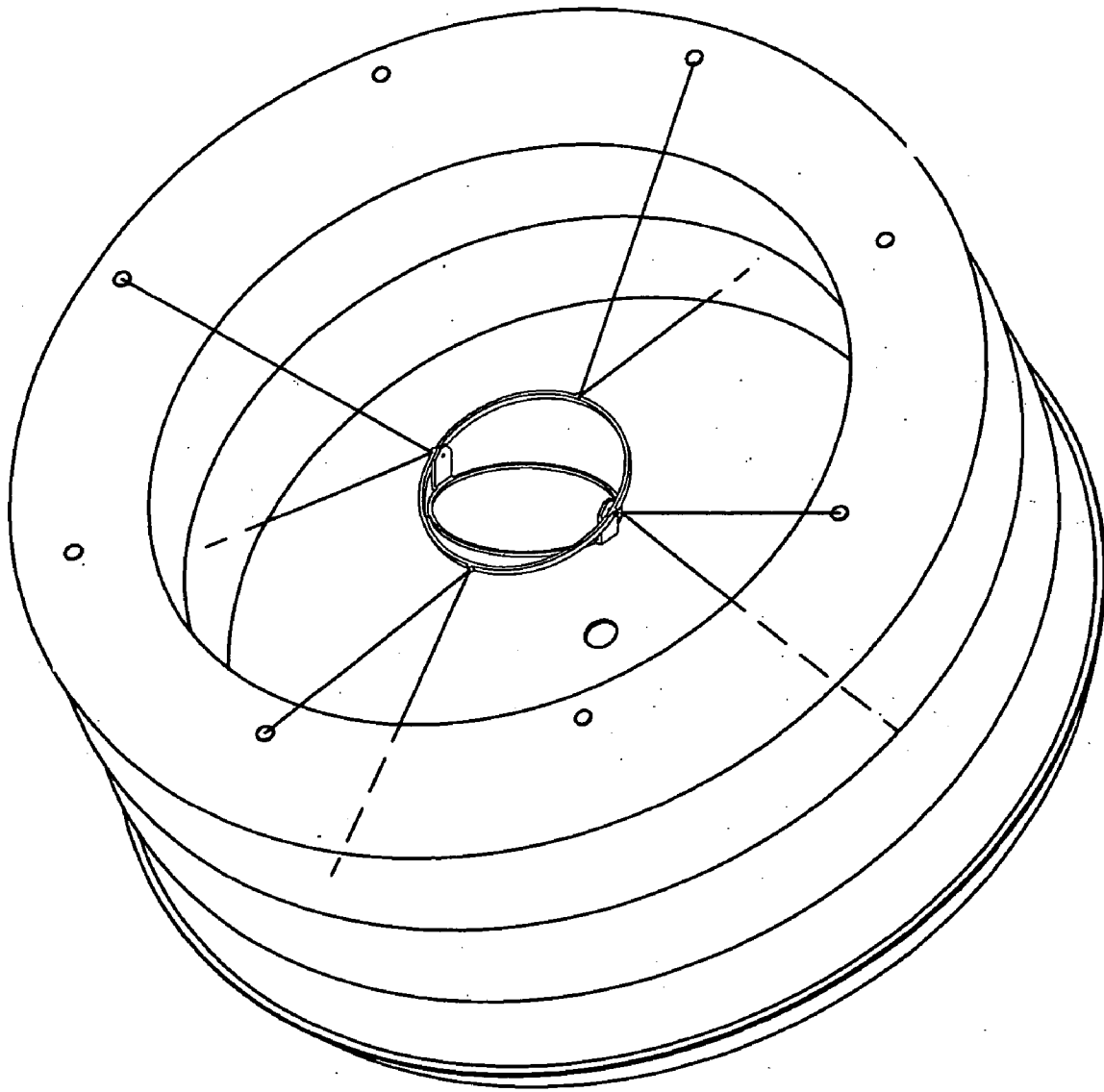

FIG. 32B

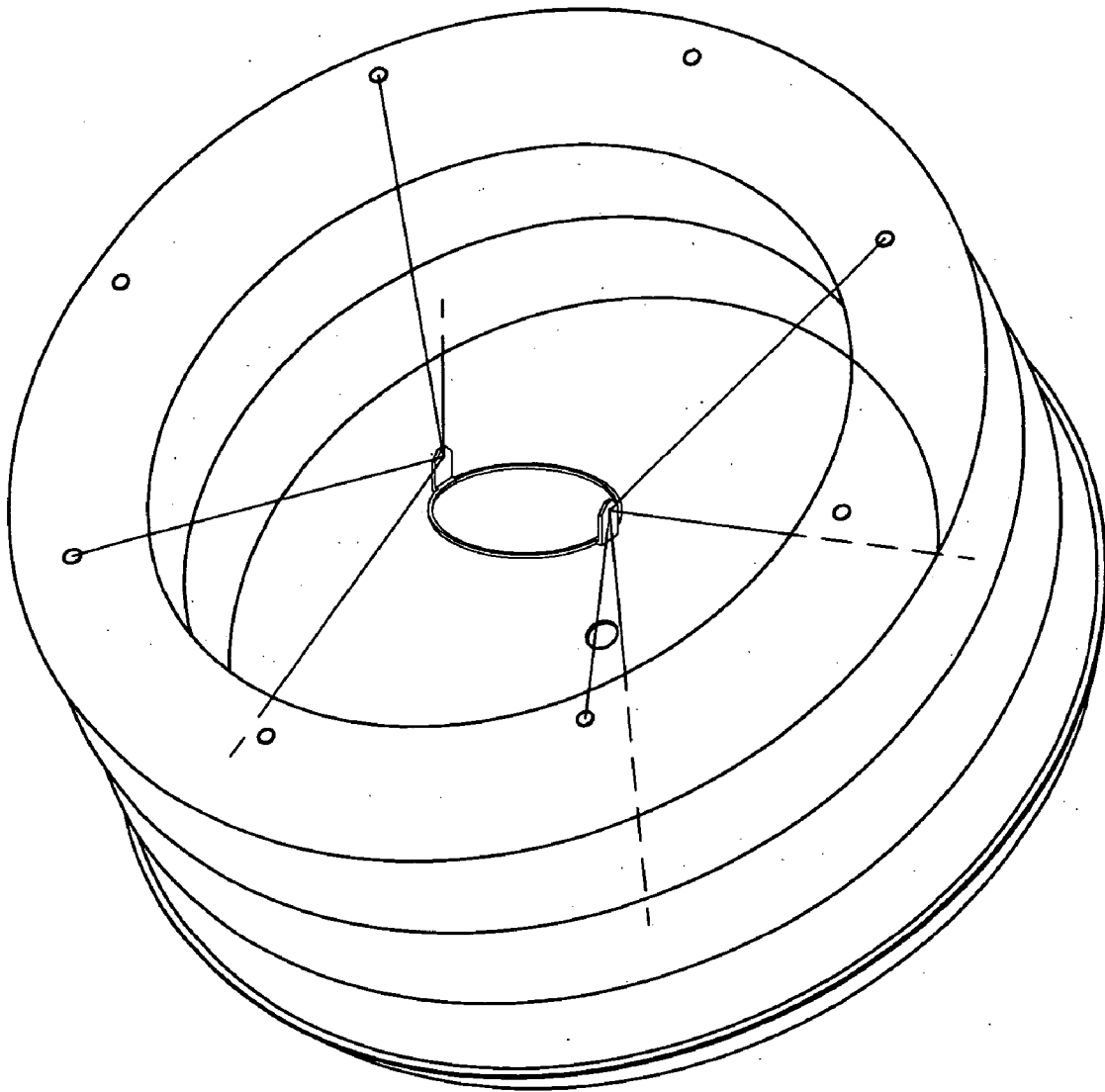

FIG. 32 C

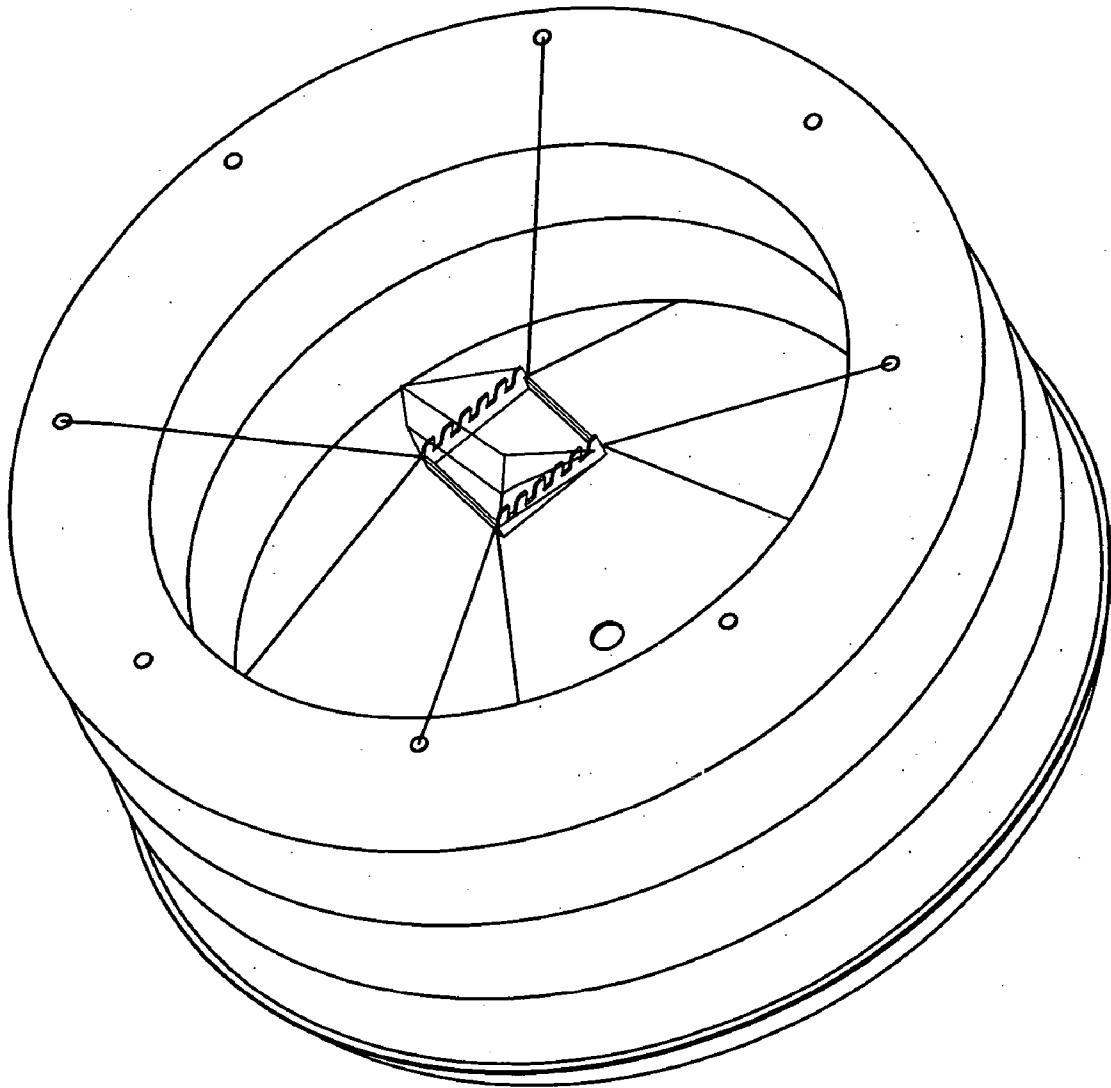

FIG. 32 D

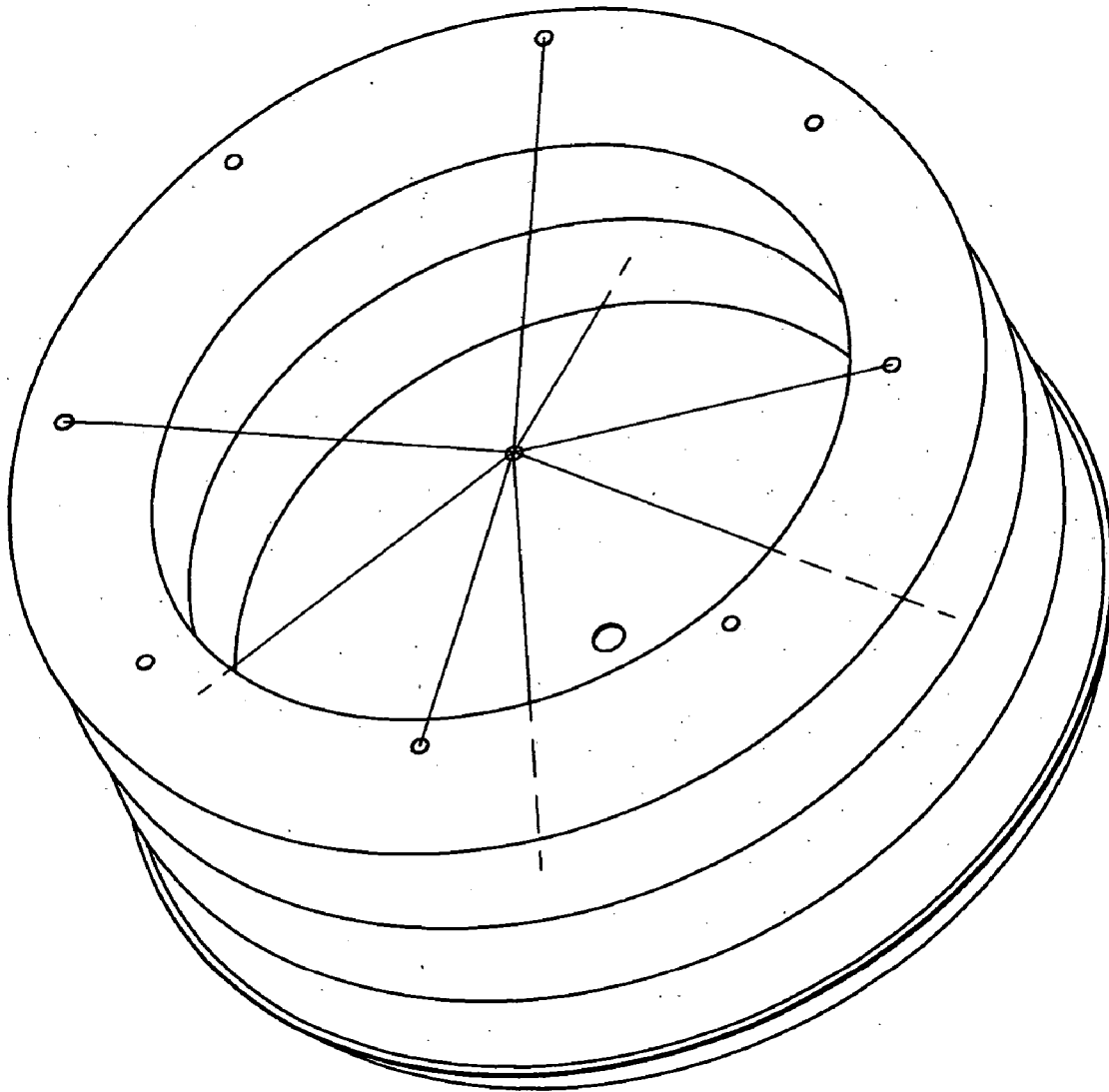

FIG. 32 E

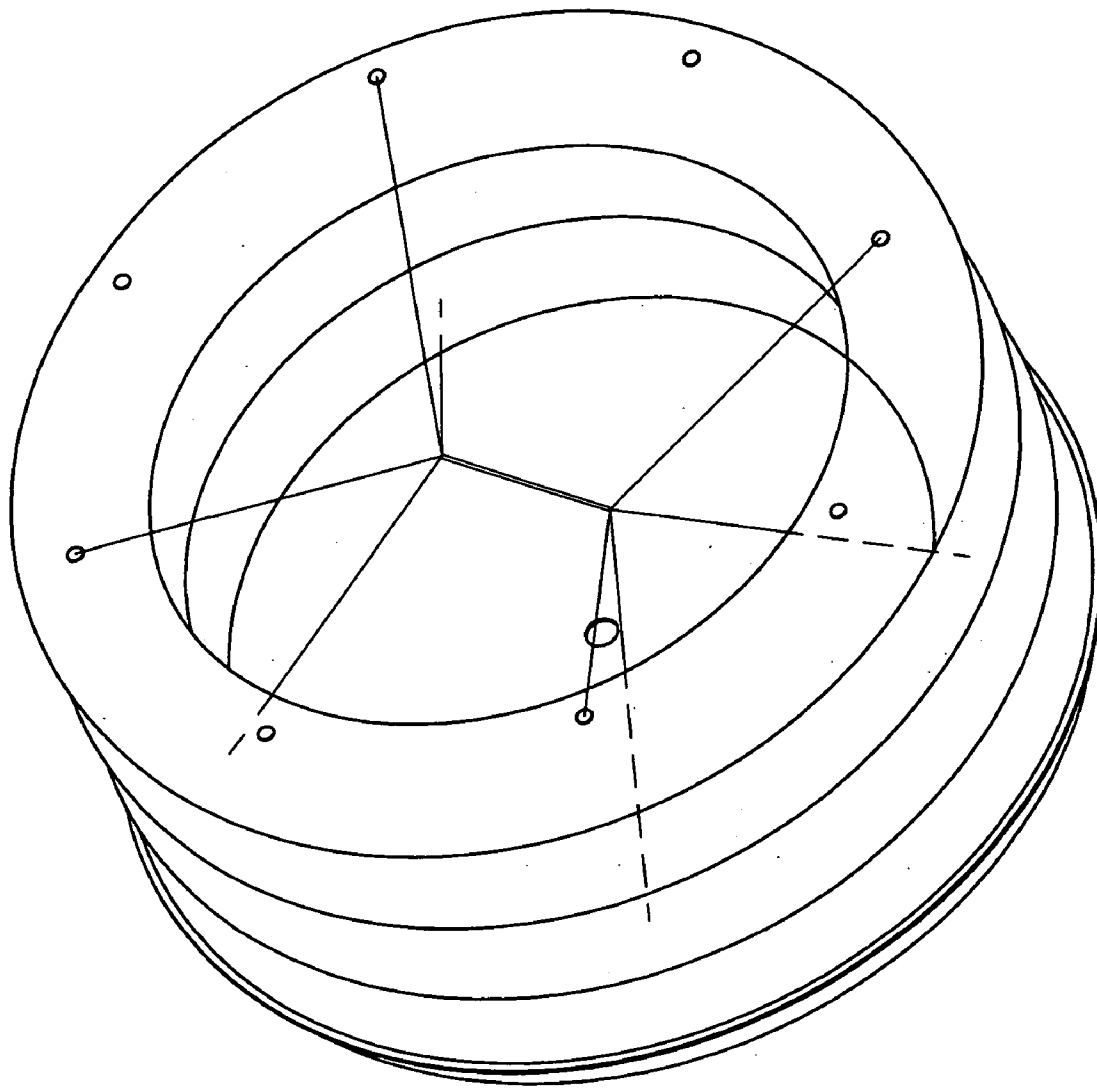

FIG. 32 F

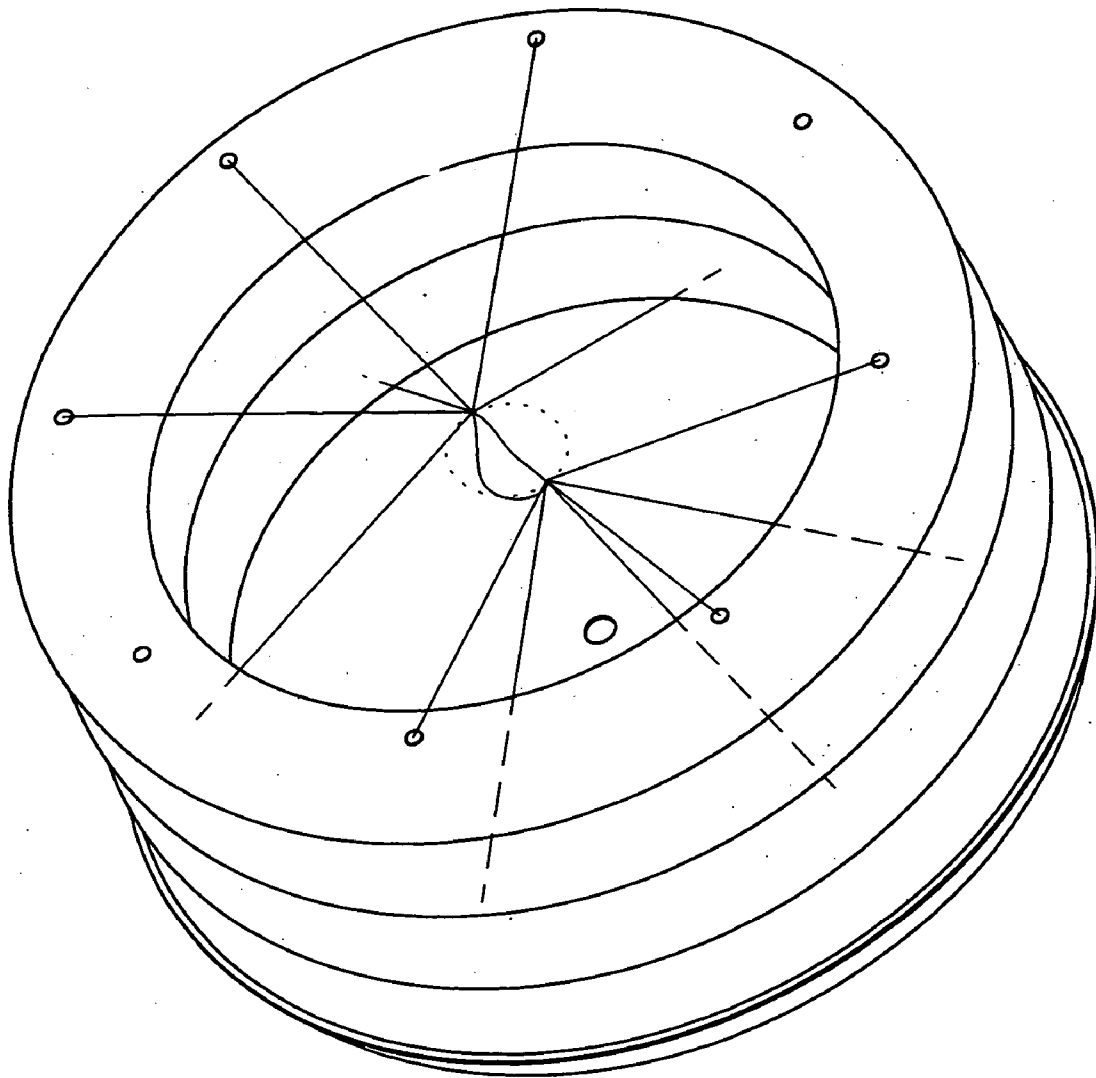

FIG. 32 B

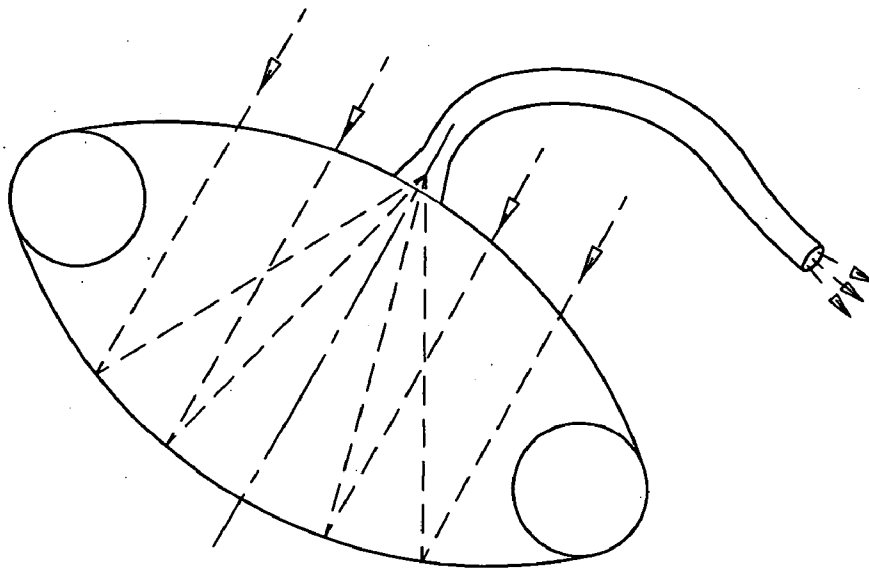

FIG. 33A

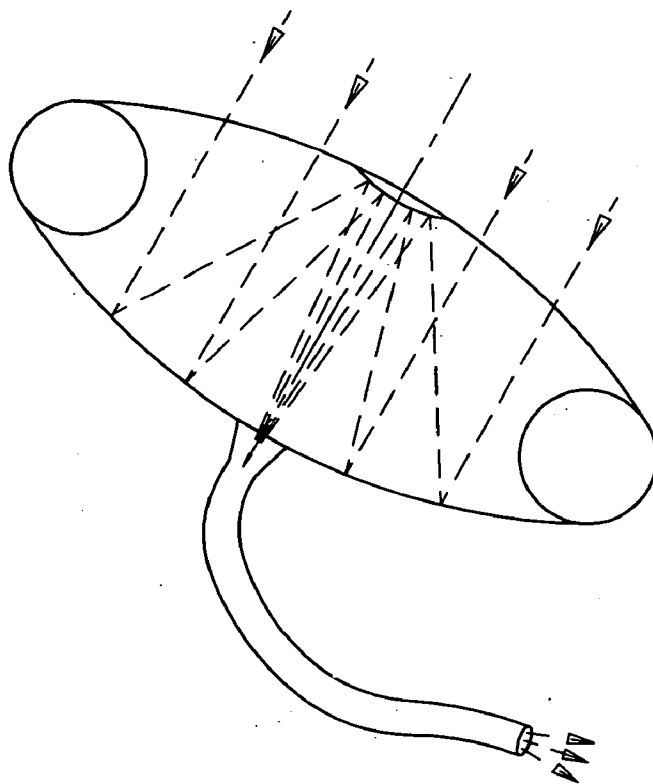

FIG. 33B

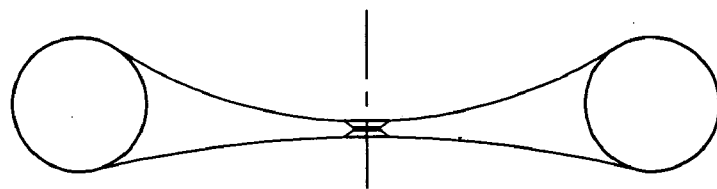

FIG. 34A

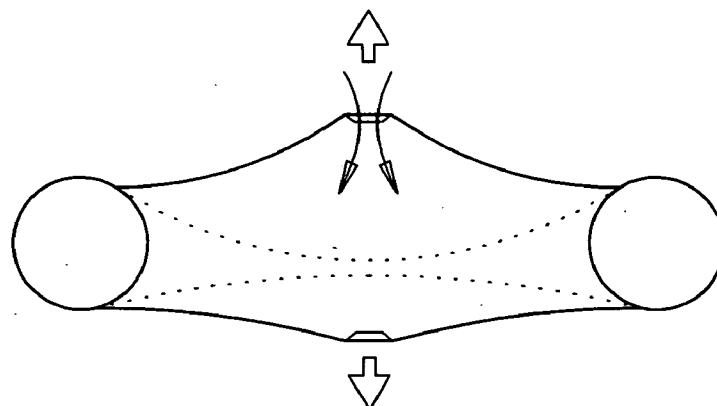

FIG. 34B

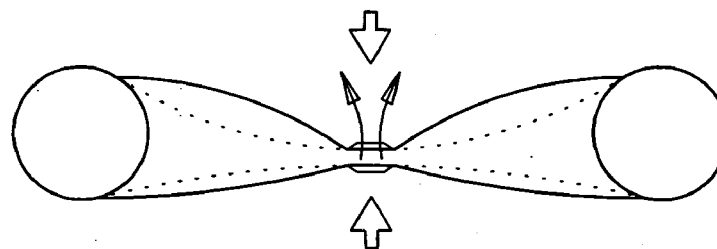

FIG. 34C

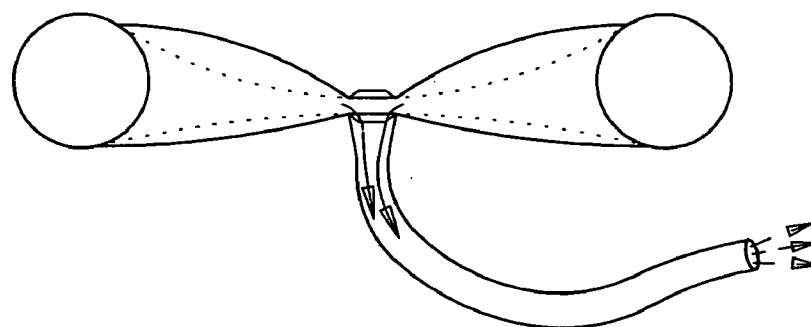

FIG. 34D

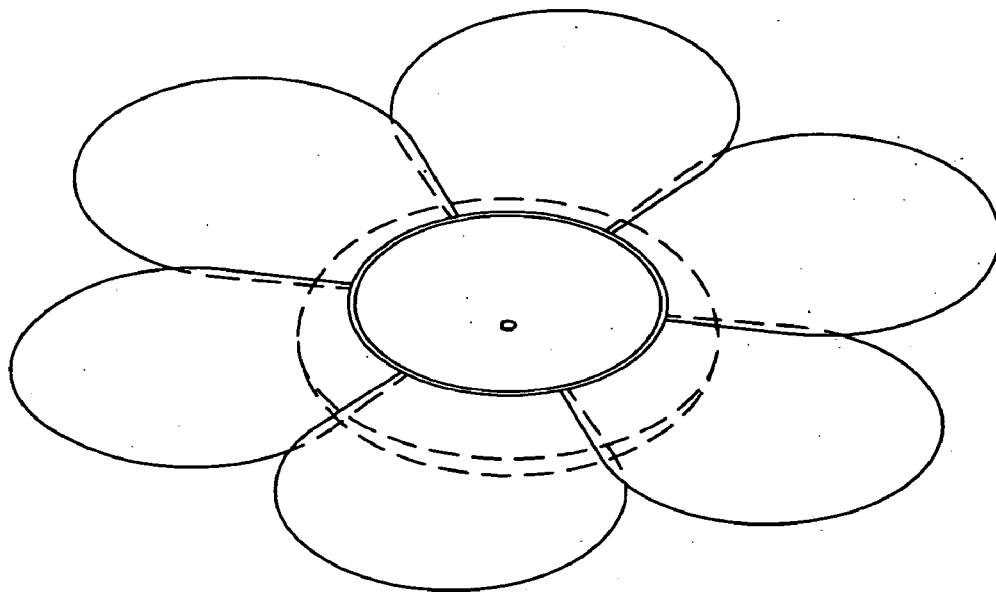

FIG. 35A

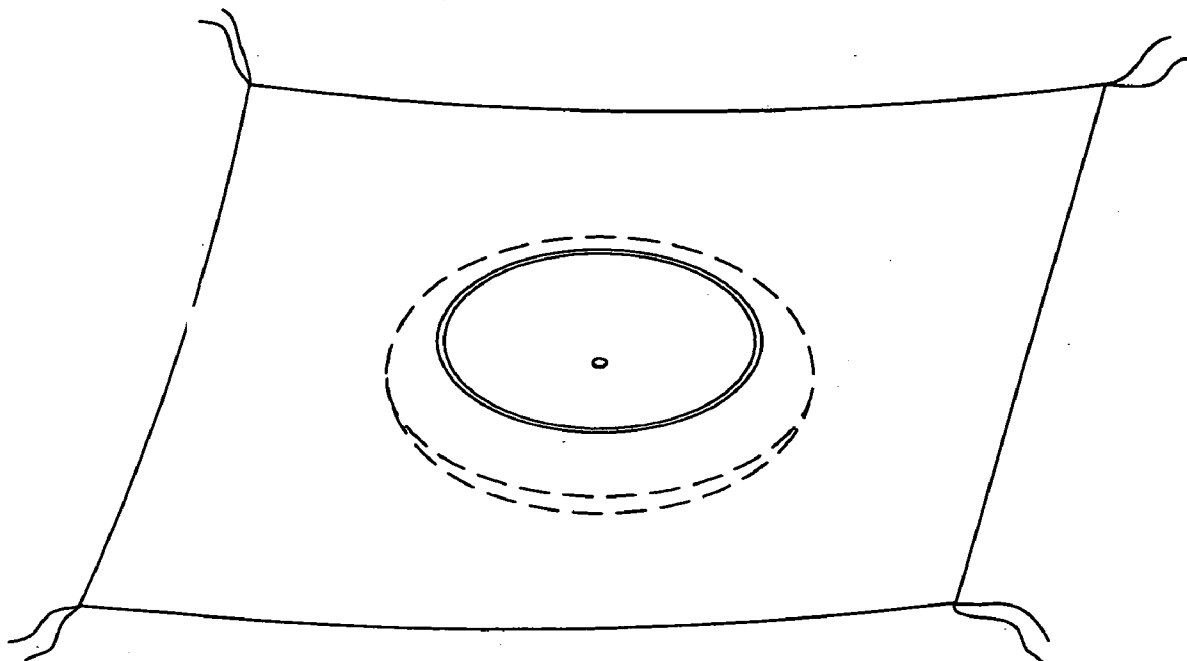

FIG. 35B

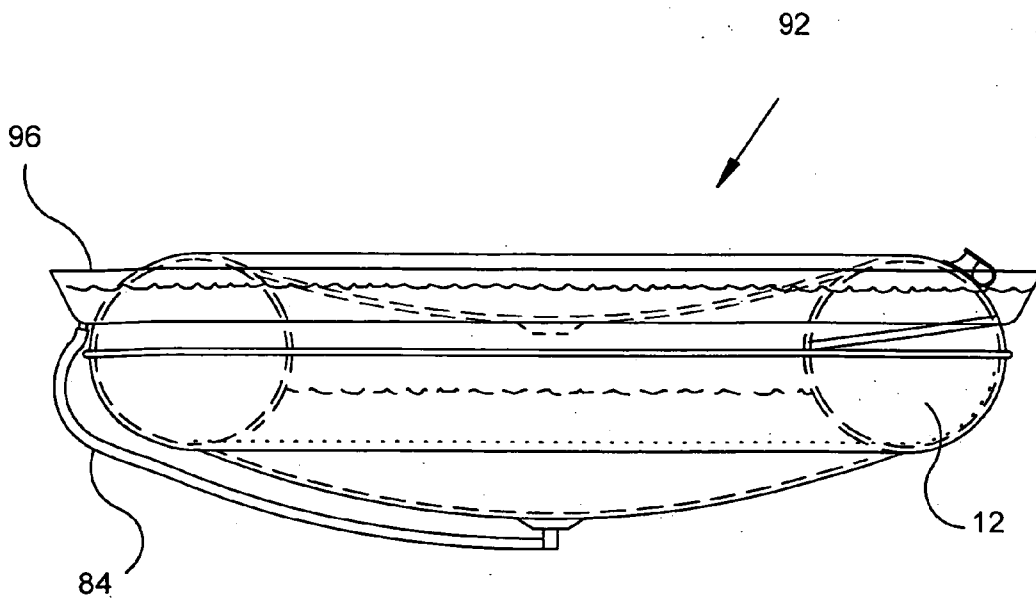

FIG. 36

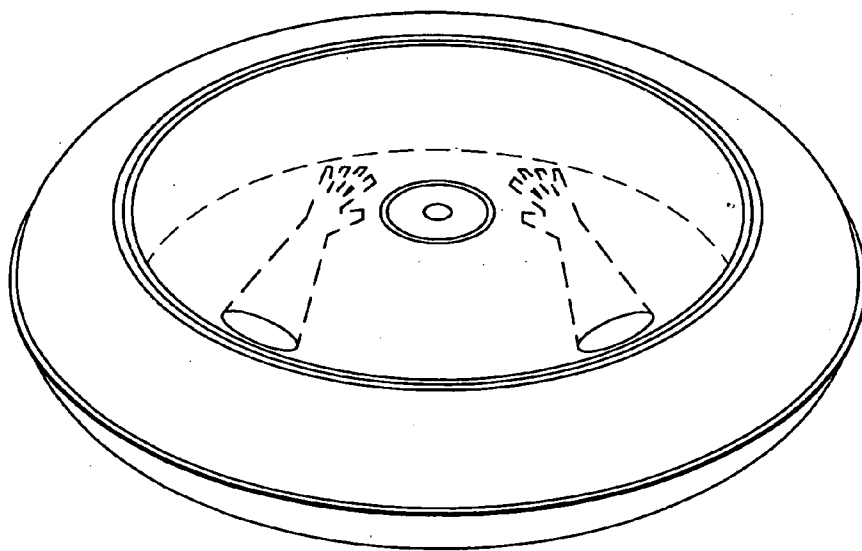

FIG. 37

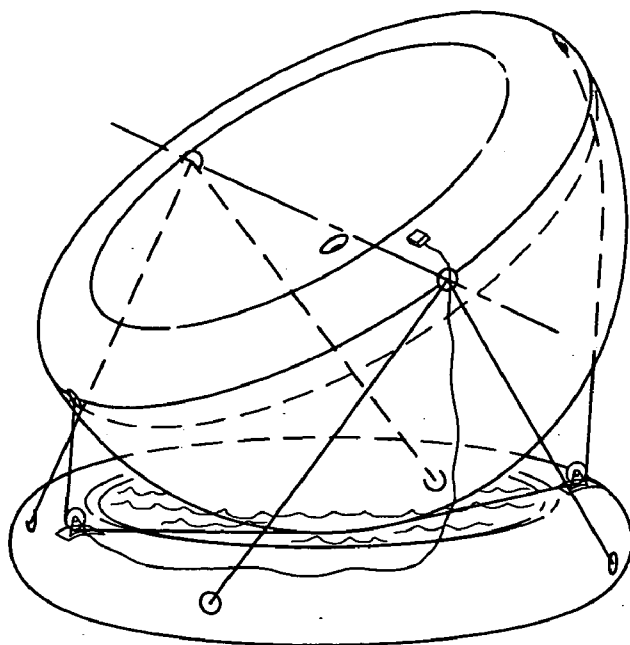

FIG. 38A

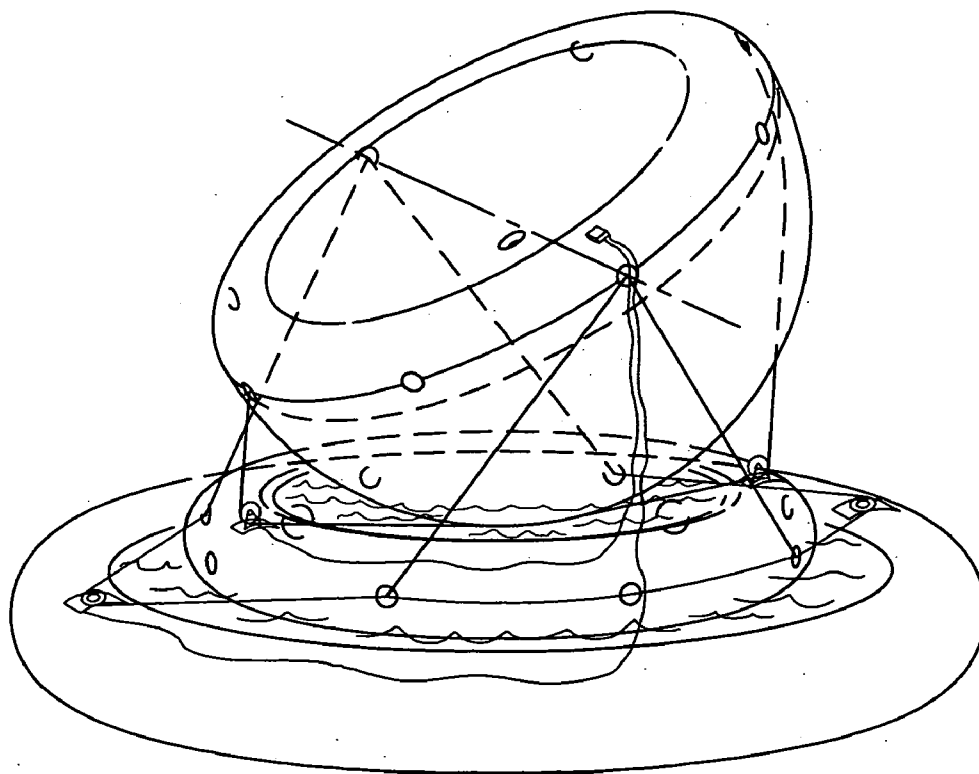

FIG. 38B

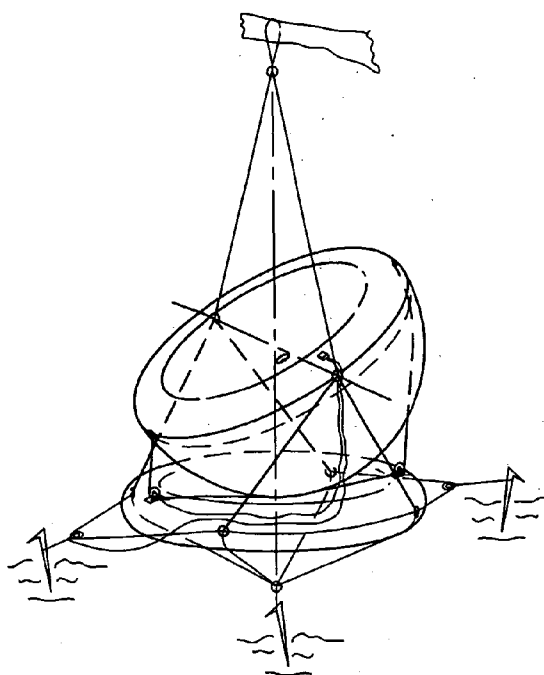

FIG. 39A

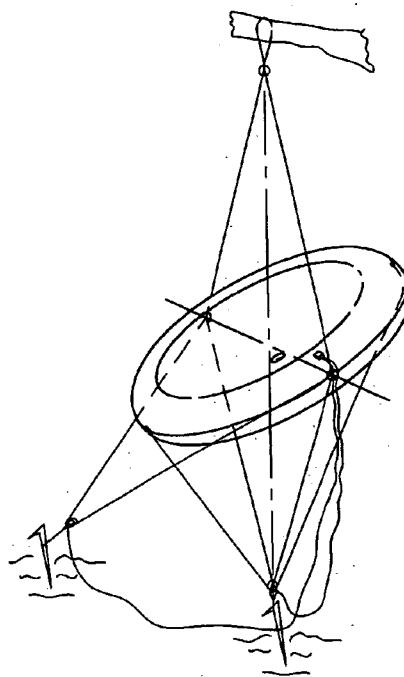

FIG. 39B

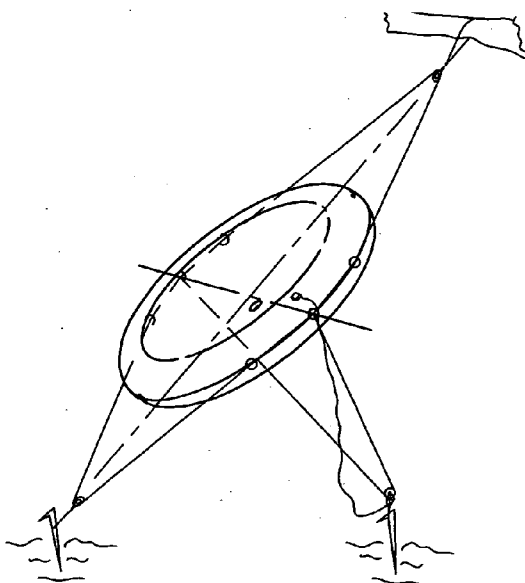

FIG. 39C

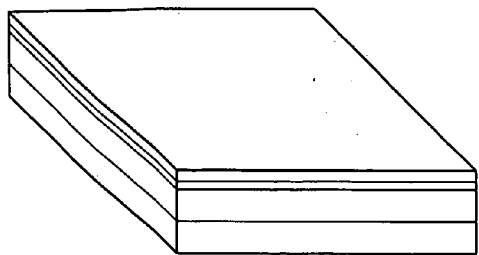

FIG. 40A

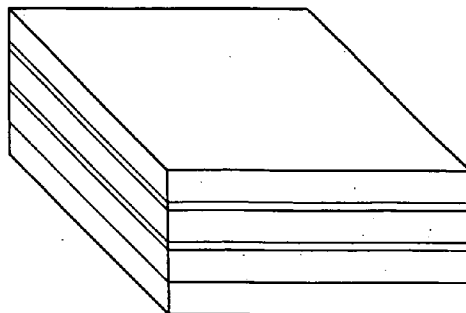

FIG. 40B

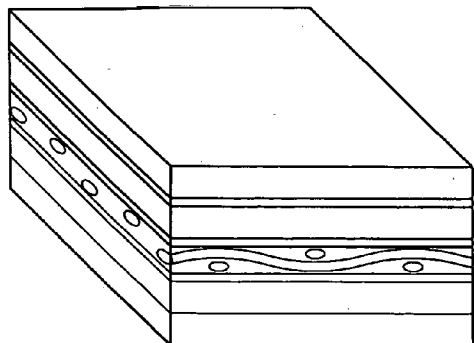

FIG. 40C

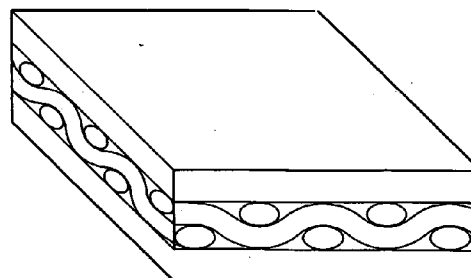

FIG. 40D

**MODULAR INFLATABLE MULTIFUNCTION
FIELD-DEPLOYABLE APPARATUS AND
METHODS OF MANUFACTURE**

**CROSS-REFERENCE TO RELATED
APPLICATIONS**

[0001] This application is a continuation-in-part of U.S. patent application Ser. No. 10/156,814, filed 30 May 2002, which claims the benefit of U.S. Provisional Patent Application Serial No. 0.60/294,440 filed May 30, 2001. This application independently claims the benefit of U.S. Provisional Patent Application Serial No. 60/403,815 filed Dec. 4, 2002. Additionally, this application relates to co-pending PCT Patent Application Serial No. PCT/US02/1.6918 as filed May 30, 2002, as amended Nov. 27, 2002 under PCT Article 19, and as amended Dec. 30, 2002 under PCT Article 34. This application also claims the benefit of PCT Patent Application Serial No. PCT/US02/16918 as amended under PCT Article 34 on Dec. 30, 2002. The entire specification (including Description, Drawing, and claims) contained within each of these related applications, both as filed and as amended (where applicable), is hereby incorporated herein by reference.

BACKGROUND OF THE INVENTION

[0002] 1. Field of the Invention

[0003] The present invention relates most broadly to multifunction field-deployable tools or apparatus, which are principally configured for use as highly portable solar cooking, heating, and/or energizing apparatus, but which typically may also be reconfigured and/or redeployed by the user in the field to serve (i.e., provide a means for performing) numerous other life-enhancing or life-sustaining functions. More specifically, the present invention relates to inflatable (or otherwise collapsible), multifunction, solar energy concentrating devices, which are typically (but not necessarily) specially configured and/or re-configurable to also effectively and reliably perform one or more other functions selected from a broad range of focused electromagnetic, non-focused electromagnetic, and/or non-electromagnetic functions, thereby rendering the invention highly amenable to a broad scope of practical applications within a wide range of terrestrial and/or non-terrestrial (e.g., marine, air-borne, space-based) environments.

[0004] 2. Related Art

[0005] a. Description

[0006] The related art of interest describes various electromagnetic energy harnessing devices including several apparatus for concentrating solar energy, but none discloses the present invention. Accordingly, there remains a need for an economical field-deployable apparatus, which, in addition to being able to concentrate solar energy for heating, cooking, and/or energizing, also provides a means for performing various other life-enhancing or life-sustaining functions, and which is fully collapsible (e.g., deflatable) to greatly facilitate portage and storage. A review of the related art reveals its many limitations and disadvantages and, thus, clearly shows that this need for a highly portable, multifunction, field-deployable apparatus remains unfulfilled, thereby underscoring the value of the present invention, which fully and uniquely meets this need.

[0007] In particular, U.S. Pat. No. 3,326,624 issued on Jun. 20, 1967, to Wladimir von Maydell et al. describes an inflatable paraboloid mirror capable of being formed into a permanently rigid structure in outer space to collect solar energy for space stations and flying bodies. The mirror has a valved annular ring, radial segmental covers or strip springs, radial heating wires, and a valved double walled mirror formed with polyester foam coated with a reflector material. The ring and mirror have internal rigid spacers. However, this apparatus is not well suited for use as a field-deployable tool because it cannot be collapsed and re-deployed after its initial deployment, it is not multifunctional, it does not provide a means for supporting and orienting the apparatus to facilitate use in a terrestrial environment, it does not provide a means for protecting the user against accidental exposure to concentrated electromagnetic radiation, and both its mechanical structure and its means of deployment are generally too complex to allow the device to be economically produced for wide use by the general public.

[0008] Other related art exhibiting many of these limitations and disadvantages include:

[0009] U.S. Pat. No. 5,920,294 issued on Jul. 6, 1999, to Bibb B. Allen describes a space antenna having an interior tensioned multiple cord attachment in a balloon which uses Mylar® for electromagnetic and solar energy applications in a first embodiment. A second embodiment utilizes an exterior tensioned cord attachment to a spacecraft of an antenna reflector of a gold-plated molybdenum or graphite wire mesh inside an inflated toroidal support balloon which uses Mylar® for electromagnetic and solar energy applications. Note that the mechanical attachments (tensioned cord-ties) used to deploy the reflector are generally too complex and also too great in number to permit economical construction of a device intended for general use by the public. Also, no means is provided for supporting and orienting the apparatus in a terrestrial environment.

[0010] U.S. Pat. No. 4,352,112 issued on Sep. 28, 1982, to Fritz Leonhardt et al. describes a large reflector having an inner face of either a polished aluminum sheet or a plastic sheet backed by individual membrane segments of a rigid foam backing having a curved concave surface and an opening in its center. Two membranes formed as concave or convex reflectors are used to reflect and concentrate solar rays to a heat absorber, heat exchanger and the like. Note that this patent is primarily a means for producing parabolic reflectors from flat planar sheets of material, and shows various rigid means for supporting and operating such reflective membranes. Further, it does not represent a portable device.

[0011] U.S. Pat. No. 2,977,596 issued on Mar. 28, 1961, to Harold D. Justice describes an inflatable circular antenna saucer on a transmitter or receiver base. Note that the rigid support frame of the apparatus is not significantly collapsible for portage and storage, and the reflector structure contains unnecessary internal webbing, which is not economical to produce.

[0012] U.S. Pat. No. 3,005,987 issued on Oct. 24, 1961, to Kent M. Mack et al. describes an inflatable antenna assembly comprising a radome covering an inflatable elliptical tubular membrane support having structural lacing and two concave flexible non-conducting sheets, wherein one sheet

is coated with vaporized aluminum. Note that the apparatus is not significantly collapsible for portage and storage, the reflector structure contains tensioning cords, which are unnecessary for use as a solar concentrator, and the radome generally inhibits or prohibits use as a broad-spectrum solar energy concentrator.

[0013] U.S. Pat. No. 3,056,131 issued on Sep. 25, 1962, to Ralph L. McCreary describes an inflatable reflector for electromagnetic radiation comprising two concave thin sheets of flexible plastic material, wherein at least one sheet has a parabolic shape. Note that the rigid support frame of the apparatus is not significantly collapsible for portage and storage. Also, no means is provided for adjustably supporting and orienting the apparatus in a terrestrial environment.

[0014] U.S. Pat. No. 3,221,333 issued on Nov. 30, 1965, to Desmond M. Brown describes an inflatable radio antenna comprising an oblate bag aerial including a pair of spaced parallel insulating planar surfaces connected to a medial portion and having two antenna elements mounted parallel to form a capacitive plate antenna. Note that this apparatus is primarily a means for producing a capacitive aerial antenna. It does not have a means for concentrating solar energy, such as a parabolic reflector, nor any means for performing any other functions except its primary (sole) use as a capacitive aerial antenna.

[0015] U.S. Pat. No. 3,413,645 issued on Nov. 26, 1968, to Richard J. Koehler describes an elongated inflatable parabolic radar antenna toroid assembly providing a small wave energy aperture in one plane and a larger wave energy aperture in a perpendicular plane. Note that this apparatus is not significantly collapsible for portage and storage, and that the reflector's support structure generally inhibits or prohibits its use as a broad-spectrum solar energy concentrator.

[0016] U.S. Pat. No. 3,471,860 issued on Oct. 7, 1969, to Floyd D. Amburgey describes a reflector antenna having a variable or flexible surface, the geometrical shape of which may be changed by air pressure or a partial vacuum behind the flexible membrane for the purpose of obtaining the best reception from this antenna type. Note that this patent is primarily a means for producing an adjustable-focal-length parabolic reflector from flat planar sheets of material. It does not represent a significantly collapsible portable device.

[0017] U.S. Pat. No. 4,672,389 issued on Jun. 9, 1987, to David N. Ulry describes an inflatable reflector apparatus and a method of manufacture. A super-ambient pressure is maintained within the envelope which is maintained by a compression frame member. Note that the rigid support frame of the apparatus is not significantly collapsible for portage and storage, and the transparent membrane of the super-ambient reflector structure limits efficiency when used as a solar energy concentrator.

[0018] U.S. Pat. No. 4,741,609 issued on May 3, 1988, to Daniel V. Sallis describes a stretched membrane heliostat having a membrane mounted on a circular frame, there being a double-walled portion of the membrane that extends in a circle near the periphery of the membrane to form a bladder that is inflatable to tension the membrane. Note that the rigid support frame of the apparatus is not significantly collapsible for portage and storage.

[0019] U.S. Pat. No. 4,755,819 issued on Jul. 5, 1988, to Marco C. Bernasconi et al. describes a parabolically-shaped

reflector antenna intended for space vehicle applications. The device is inflated by a gas in space to form an antenna reflector and an antenna radome stabilized by a rigidizing torus. The covering material is a resin-impregnated fabric which when heated by the sun polymerizes to render the reflector antenna stable and requires no gas pressure to keep its shape. Note that this apparatus is not significantly collapsible for portage and storage, it is too complex to yield a sufficiently economical field-deployable tool for use by the general public, and the radome generally inhibits or prohibits its use as a broad-spectrum solar energy concentrator.

[0020] U.S. Pat. No. 5,276,600 issued on Jan. 4, 1994, to Takase Mitsuo et al. describes a planar reflector composed of a base and a flexible polymeric plastic substrate having a highly reflective silver layer formed thereon and overlaid on the base with an adhesive layer interposed between the two layers. Note that this patent is primarily a means for producing reflectors having a small radius of curvature from multi-layer planar sheets of material. It does not represent a functional collapsible reflector apparatus.

[0021] U.S. Pat. No. 5,893,360 issued on Apr. 13, 1999, to O'Malley 9. Stoumen et al. describes an inflatable solar oven comprising two sheets of flexible material sealed at their edges. The top sheet is clear and the bottom sheet has a reflective layer. Note that this apparatus exhibits an extremely clumsy or cumbersome method of cooking, and the functionality of the device is easily impaired by vapors, which after being emitted from the items being heated or cooked within the device, may then condense on the transparent membrane of the device, thereby diffusing the impinging solar radiation, thus preventing effective concentration. Further, the device is not multifunctional.

[0022] U.S. Pat. No. 6,150,995 issued on Nov. 21, 2000, to L. Dwight Gilger describes a combined photovoltaic array and a deployable perimeter truss RF reflector. Note that this structure is highly complex in light of its two simple functions, and it is generally not suitable for use as a terrestrial field-deployable tool.

[0023] U.S. Pat. No. 6,219,009 issued on Apr. 17, 2001, to John Shipley et al. describes a tensioned cord and tie attachment of a collapsible antenna reflector to an inflatable radial truss support structure. Note, again, that the mechanical attachments (tensioned cord-ties) used to deploy the reflector are generally too complex to permit economical construction of a device intended for general use by the public. Also, no means is provided for supporting and orienting the apparatus in a terrestrial environment.

[0024] U.K. Patent Application No. 758,090 published on Sep. 26, 1956, for Charles T. Suchy et al. describes an inflatable balloon having arranged within a radio aerial. Note that this apparatus does not have a concentrating reflector.

[0025] France Patent Application No. 1.048.681 published on Dec. 23, 1953, for Adnan Tarcici describes a reflector for concentrating solar energy for cooking when camping. Note that this apparatus is not significantly collapsible for portage and storage.

[0026] Japan Patent Application No. 59-97205 published on Jun. 5, 1984, for Yasuo Nagazumi describes a parabolic antenna having an airtight chamber filled with nitrogen and demarcated with a radiating aluminum casing and a heat-

insulating mirror. Note that this apparatus is not significantly collapsible for portage and storage and is not suitable for concentrating solar energy.

[0027] b. Summary of Disadvantages of Prior Art

[0028] In short, the disadvantages of prior art generally include, among others, one or more of the following limitations:

- [0029] (a) the device or apparatus generally is not multifunctional in nature, i.e., it is generally limited to either a single function or perhaps two or more closely related functions;
- [0030] (b) the apparatus is not suitably or sufficiently collapsible to permit easy transport to and from the field, or allow convenient storage when not in use;
- [0031] (c) the apparatus is not easily reusable or re-deployable, i.e., the apparatus cannot be collapsed after its initial deployment to facilitate portage to an alternate location or to compactly store for future use.
- [0032] (d) the apparatus has no lightweight collapsible means for supporting and orienting the apparatus-to facilitate use in a terrestrial environment, and/or it does not employ other features to facilitate use by persons having limited experience or knowledge, such as simple well-known inflation valves;
- [0033] (e) the apparatus has no means for protecting the user from accidental exposure to highly concentrated electromagnetic radiation, thereby posing a safety hazard;
- [0034] (f) the apparatus exhibits limited efficiency when concentrating broad-spectrum solar radiation as a result of having one or more intervening layers in its optical path, such a transparent membrane or radome;
- [0035] (g) the apparatus exhibits unnecessary structural complexity, thereby rendering the apparatus uneconomical to produce for wide use by the general public; and/or
- [0036] (h) the apparatus is generally not suitably robust or sufficiently durable for rapid deployment into the field, such as by air drop, nor does the apparatus provide a means for easily repairing the device in the field using integral rapid-repair materials in the event of damage.

[0037] In contrast, each of these disadvantages or limitations of prior art are overcome by the present invention.

SUMMARY OF THE INVENTION

[0038] a. General Description

[0039] The present invention is a modular, inflatable, multifunction, field-deployable apparatus, which primarily provides an economical means for concentrating solar energy for heating, cooking, and/or energizing, but which also typically provides various means for performing other life-enhancing or life-sustaining functions, and which is generally fully collapsible (e.g., deflatable) to greatly facilitate portage and storage. Briefly, the modular, inflatable, multifunction, field-deployable apparatus of the present

invention typically has as its primary functional module a basic inflatable, multifunction, parabolic reflector apparatus, such as disclosed in our previous (cross-referenced) applications. The present invention typically further includes one or more optional, preferably removably attached, accessory modules and/or elements, such as an inflatable (or otherwise collapsible) means for supporting and orienting the basic inflatable reflector apparatus, an inflatable (or otherwise collapsible) means for protecting the user from accidental exposure to highly concentrated electromagnetic (e.g., solar) radiation at or near the focal point of the basic reflector apparatus, an inflatable (or otherwise collapsible) means for supporting materials or accessory elements in proximity to the focal point, and an inflatable (or otherwise collapsible) protective cover.

[0040] Regarding functionality, briefly note that both the basic inflatable reflector apparatus of the basic invention and, thus, the modular field-deployable apparatus of the present invention are primarily configured for use as highly portable solar cooking, heating, and/or energizing apparatus. However, both the basic reflector apparatus and the modular field-deployable apparatus are typically (but not necessarily) specially configured to also effectively and reliably perform, either alone or in concert with various optional accessory elements, one or more other functions selected from a broad range of focused electromagnetic, non-focused electromagnetic, and non-electromagnetic functions. Hence, both the basic reflector apparatus and the modular field-deployable apparatus can serve as highly portable multifunction tools, each of which is highly amenable to a broad scope of practical applications; however, the modular apparatus of the present invention offers greater versatility, safety, and ease of use.

[0041] In greater detail, the present invention is generally functionally optimized (as is the basic invention) for concentrating, focusing, and/or beaming radiant electromagnetic energy and is effective over a wide range of the electromagnetic spectrum from radio frequency (RF) radiation through ultraviolet (UV) radiation including broad-spectrum solar energy. However, as indicated above, the present invention (and the basic invention) can also effectively and reliably perform numerous other functions not related to concentrating, focusing, and beaming radiant electromagnetic energy. Focused electromagnetic applications, of the present invention typically include 1) concentrating broad-spectrum (e.g., solar) radiation for heating, cooking, sterilizing, distilling, processing materials, generating electrical power, and/or the like, (2) manipulating radio and/or microwave frequency radiation for enhancing the transmission and reception of radio signals and/or other electromagnetic communications, and/or (3) manipulating visible-spectrum radiation for enhancing vision in low-light environments, projecting optical signals or images, and/or other optical purposes, such as using the apparatus as a convex mirror to extend the user's field of vision for surveillance and/or safety. Non-focused, electromagnetic applications typically include 1) use as an emergency thermal blanket, shelter, incubator, greenhouse, and/or the like, (2) use as an electromagnetic energy shield, and/or (3) use as an electrostatic insulator. Non-electromagnetic applications typically include. (1) the collection, storage, and/or processing of water or other substantially fluidic materials, (2) use as a shelter to protect persons, equipment, materials, and/or other items from inclement weather and/or other

environmental elements, (3) use as a soft or compliant support such as a bed, cradle, inflatable cast (for immobilizing a broken limb), and the like, (4) use as a water flotation device or water boat, (5) use as a portable fermentor apparatus for producing fuels, medicines, beverages, and/or other materials, (6) use as an inflatable wind turbine for producing electrical and/or mechanical power, and/or (7) use as a directional sound amplification device. The invention contemplates numerous other uses as discussed hereinbelow and as readily apparent to a user of the apparatus. However, it is emphasized that any particular embodiment or manifestation of the present invention need not perform all such functions, i.e., a particular embodiment can be configured to perform a limited number or subset of these functions without departing from the nature of the invention. Further, as will be shown below, it should be noted that although the basic reflector apparatus is generally the primary functional module of the modular field-deployable apparatus, the present invention (i.e., the modular field-deployable apparatus) can optionally be reconfigured without a basic reflector apparatus by the user in the field (or by the factory) to perform various non-focused electromagnetic and/or non-electromagnetic functions, for example, use as a water flotation device or use as part of a wind turbine apparatus, without departing from the nature of the invention.

[0042] Regarding physical construction, first note that each of the modular structures of the present invention are generally optimized to minimize weight, non-deployed volume, and production cost, while simultaneously maximizing operational performance, versatility, and safety. To achieve such optimization, the primary modules of the present invention are typically made from one or more lightweight inflatable structures (such as an inflatable ring), thin flexible (e.g., pressure-deployable) membranes, and/or other easily collapsible, light weight structures. An excellent example of such structural optimization is the basic inflatable reflector apparatus in a preferred first main embodiment configuration, wherein two pressure-deformable (i.e., pressure-deployable) membranes, at least one of which is reflective, are utilized in conjunction with the inner portion of an inflatable support ring to form a highly efficient central reflector chamber, which generally can be inflated to either sub-ambient pressure (as required for most applications) or super-ambient pressure to deploy the reflective membrane(s). Note that by using the inner portion of the support ring to form an integral part of the highly efficient sub-ambient-pressurizable reflector chamber, the first embodiment of the basic reflector apparatus can be produced very economically from a minimum number or parts while maximizing weight-specific power output.

[0043] As another example, a second main embodiment of the basic reflector apparatus utilizes at least one reflective membrane and at least one transparent membrane to form a central reflector chamber, which generally can be inflated only to super-ambient pressure to deploy the reflective membrane. Although generally less efficient than the first embodiment when used for concentrating broad-spectrum electromagnetic energy, the primary structure of the second embodiment of the basic reflector apparatus can be made extremely economically from as few as two sheets of material. Additionally, both embodiments of the basic reflector apparatus generally employ one or more reflective membranes which are pre-formed substantially into the shape of a paraboloid to enhance safety, facilitate operation, and

reduce structural loading of the membranes on the support ring. (It is noted that a "pre-formed" pressure-deformable membrane is a membrane which is fabricated to substantially embody or possess its pressure-deformed shape, i.e. its deployed surface contour, prior to the application of significant differential pressure across the membrane.) As noted above, the other modules of the present invention are also typically constructed from similar lightweight inflatable structures and/or pressure-deployable membranes to achieve such structural optimization; however, it should be further noted that particular modules (or components thereof) are also sized to substantially match, where possible, other modules and/or components of the present invention, both to further reduce fabrication cost by minimizing the number of different elements required to construct the modular apparatus, and to allow similarly sized modules to be easily interchanged to increase versatility of the modular apparatus and/or to facilitate rapid substitution of one or more modules in the event of damage.

[0044] To enable the various modules of the present invention to operate as a unit, each module typically includes one or more attachment means for connecting to other modules of the apparatus, for attaching accessory elements, and/or for securing and stabilizing the apparatus to promote safe operation. Additionally, each inflatable and/or pressure-deployable module of the apparatus requires at least one inflation means or pressure-adjusting means such as, for example, a simple well-known plug valve, a manual or automatic pump, a gas canister, and/or the like.

[0045] To increase performance, further enhance safety, facilitate use, reduce production cost, and/or to enable the modular field-deployable apparatus to perform additional functions, the present invention contemplates that numerous alternate configurations, optional features, and/or accessory elements typically can be substituted for, incorporated into, and/or used in concert with the various modules of the present invention.

[0046] Regarding alternate configurations, note, for example, that the use of non-preformed (i.e., planar) elastic reflective membranes is contemplated to enable the basic reflector apparatus to have a variable focal length. Further, the use of pre-formed, non-parabolic reflective membranes (e.g., reflective membranes having surfaces which are spherical, undulating, a series of conic sections, faceted, and/or the like) is contemplated to limit the maximum degree of concentration to further enhance safety. In addition, the invention also contemplates various novel methods of manufacture for the various modules. More specifically, various fabrication processes, such as those disclosed in our previous (cross-referenced) applications, may be employed to economically produce the present invention primarily from multiple, thin, flexible (e.g., pressure-deformable) membranes.

[0047] Regarding optional features and/or accessory elements, note that such elements can be either integrally incorporated within or removably attached to the various modules of the present invention. Also note that the various modules of the apparatus may be integrated, such as to permit simultaneous inflation of the integrated, interconnected modules.

[0048] Specific portable apparatus are shown hereinbelow which greatly facilitate or enable a wide range of useful

applications. However, the invention contemplates that many other portable apparatus may be provided for various purposes by judiciously combining one or more of the modules of the modular field-deployable apparatus (or alternate configurations thereof) with any of the numerous optional features and/or accessory elements of the present and/or basic invention, i.e. the invention is not limited to the specific examples shown and/or described herein.

[0049] Ultimately, the present invention serves as a highly portable, field-deployable, multi-function, multi-purpose apparatus or tool, which can quickly and economically provide in the field (or other partially or significantly infrastructure-deprived environment) at least one life-enhancing or life-sustaining function or utility. More specifically, the invention can perform many of the life-sustaining functions and/or utilities routinely provided by much more massive, semi-portable apparatus and/or substantially fixed elements of infrastructure that are typically found within highly infrastructure-rich environments. Consequently, the highly portable multifunction apparatus of the present invention can rapidly, effectively, and economically replace and/or supplement, either temporarily or permanently, many of these life-sustaining apparatus and/or elements of infrastructure, examples of which include various domestic (i.e. household) appliances and/or other housewares; research, commercial, industrial, recreational, and/or military equipment; municipal power, water, and/or communication utilities; basic shelter from inclement weather or other environmental elements; and/or the like. Accordingly, the present invention is ideally and uniquely suited to facilitate a broad range of activities including, for example, remote field work, emergency response, disaster relief, outdoor recreation (such as camping, backpacking, picnicking, boating, and/or the like), education, and/or other activities in terrestrial and/or non-terrestrial (e.g., marine, airborne, space-based) environments.

[0050] b. Typical Advantages Over Prior Art

[0051] Hence, the modular inflatable multifunction apparatus comprising the present invention is generally superior to the related art in at least seven very significant respects.

[0052] First, the present invention is superior to the related art as a result of its highly multifunctional, multipurpose nature. It is noted that the preferred and alternate embodiments of the present invention have numerous electromagnetic and non-electromagnetic utilities. In contrast, all related art is significantly more limited with respect to utilities and applications thereof. In greater detail, it is emphasized that none of the prior art makes any references to, or accommodations for, performing non-electromagnetic functions, such as water collection and storage, which is but one of many critically important aspects of the present invention when the apparatus is deployed in the field as a multifunctional survival tool. In addition, the modular nature of the present invention allows the various modules of the apparatus to be used simultaneously for similar and/or radically different functions; however, prior art contains no such provision.

[0053] Second, the present invention is superior to the related art as a result of its extremely lightweight and compactly foldable construction, which greatly facilitates portage and storage. As an example, note that a pocket-sized version of the basic inflatable reflector apparatus having a

mass of approximately 100 grams and measuring only 8.5 cm by 12.0 cm by 1.0 cm when fully collapsed can be inflated to yield a fully deployed device having a 120 cm diameter primary reflector providing 1000 watts of highly concentrated broad-spectrum radiant energy when utilized terrestrially as a solar energy concentrating device. It is noted that such a device can thus provide an unprecedented mass-specific power output approximating 10000 watts per kilogram, depending on the specific thickness and material of construction (e.g., a 13-micron-thick nylon/polyethylene co-extruded membrane), and a non-deployed, compactly folded, volume-specific power output (i.e., non-deployed power density) approximating 10 megawatts per cubic meter. As a result, a single cargo air lifter can, for example, airdrop in a single load a sufficient quantity of the apparatuses to capture and concentrate well over 100 megawatts of solar energy. Although a modular apparatus incorporating several inflatable accessory modules generally has a lower weight-specific and volume-specific power output than the basic inflatable reflector apparatus, it should be noted that such inflatable accessory modules of the modular apparatus optionally can be constructed from one or more modified basic reflector apparatuses such that the modified modular apparatus can be reconfigured as a plurality of basic inflatable reflector apparatuses, which substantially achieve the same high weight-specific and volume-specific power output of the primary basic inflatable reflector apparatus.

[0054] Third, the present invention is superior to the related art as a result of its precisely pre-formed reflective membranes and other optional features, which greatly increase the operational safety of the device. More specifically, the use of pre-formed parabolic reflective membranes (instead of planar membranes as generally used in related art) allows the device to have (and can limit the device to) relatively short and substantially fixed focal lengths, thereby enabling the user to maintain greater control over the location of any potentially dangerous, high concentrations of radiant energy. In addition, pre-formed, non-parabolic reflective membranes may be used to, limit the maximum degree of energy concentration to lower and, thus, safer levels. Further, the use of optional integral safety cages, safety covers, and/or other safety features significantly reduces the risk of accidental exposure to high concentrations of electromagnetic radiation. Again, such features and their associated benefits are not contemplated by prior art.

[0055] Fourth, the present invention is superior to the related art in that it is easier to deploy (e.g. inflate) and operate. Note that by using pre-formed reflective membranes, such reflective membranes can be fully deployed using significantly less differential pressure across the membranes, thereby facilitating proper inflation. In addition, various optional elements may be incorporated into the device, which further enhance ease-of-use during deployment and/or operation. For example, such elements include (1) various novel means for supporting and/or orienting the device, (2) various novel apparatus for holding materials or accessory elements in proximity to the focal point, and (3) the use of simple, well-known inflation valves, which greatly facilitate deployment, even by persons having limited education or prior experience with solar concentrating apparatus. In contrast, except for the occasional use of well-known focal point supports, prior art neither contemplates nor anticipates such elements or the benefits thereof.

[0056] Fifth, the present invention, when employing a first embodiment configuration of the basic reflector apparatus, is more efficient in that it eliminates all loss-inducing intervening layers as contained within the optical paths of all closely related prior art, i.e. art employing pressure-deformable reflective membranes supported by an inflatable ring. Note that by employing a sub-ambient pressure reflector chamber, as is used in the first embodiment of the basic reflector apparatus, sunlight or other electromagnetic radiation can travel, unobstructed, from the energy source to the reflector and then to the target. Accordingly, the first embodiment of the basic reflector apparatus causes no (i.e., zero) losses of radiant electromagnetic energy as such energy travels to and from the reflector. In contrast, most related art requires sunlight or other electromagnetic radiation to pass through the transparent membrane of a super-ambient reflector chamber on its way to and from the reflector, thereby resulting in a plurality of losses. The remaining prior art, although utilizing a sub-ambient pressure reflector chamber, also requires the electromagnetic energy to pass through at least one intervening layer, such as a radome, again resulting in a plurality of losses. In general, these losses include the reflection, absorption, and diffusion of electromagnetic radiation by the intervening layer as the radiation travels to and from the reflector. Ultimately, the intervening layers of prior art are typically responsible for reducing the efficiency of such devices by as much as twenty percent, or more, depending upon the wavelength of the impinging radiation and the transmission characteristics of the material or materials comprising the intervening layer.

[0057] Sixth, the present invention (most notably its basic reflector apparatus) is superior to the related art as a result of its extremely simple, highly integrated structure, which has been specially configured to facilitate high-speed mass-production, thereby making the device very economical to produce. Note that the designs specified in the related art do not demonstrate the high degree of integration and resulting simplicity of construction to the extent specified herein for the present invention. Also note that the relative simplicity of the present invention is due, in part, to the fact that the reflective membrane of its basic reflector apparatus can be deformed into a substantially parabolic surface utilizing only the surrounding ambient (i.e. atmospheric) pressure and simple, manually-operated, integral valves. In contrast, all related art relies on complex mechanical arrangements, complex electrostatic systems, or complex pressure adjusting systems to deform the reflective membrane into a substantially parabolic surface.

[0058] Seventh, the present invention is superior to prior art as a result of possessing a superior degree of robustness, especially when deployed into the field via airdrop or other potentially high-acceleration-inducing delivery methods. Note that such robustness of design is a result of the nearly exclusive use of thin flexible membranes (instead of rigid structures) to produce the apparatus. Further, in the event of damage, the apparatus is also superior to prior art in that it exhibits superior maintainability, which is achieved by incorporating an integral means for rapidly repairing the apparatus in the field. In contrast, the related art provides no such means for conveniently maintaining the apparatus in the field.

[0059] It should be noted that each of the above aspects of the present invention, taken separately, represents a signifi-

cant improvement over prior art. However, in combination, these superior aspects of the present invention represent an enormous improvement over prior art, the significance of which should not be underestimated. More specifically, as a result of possessing all of the noted improvements over prior art, the present invention can effectively serve as a highly multifunctional, highly portable, generally safe-to-operate, easy-to-use, high-performance, and highly economical tool—a tool which has the ability to significantly enhance one's ability to enjoy and/or survive a variety of difficult or demanding physical environments, which, for a variety of reasons, have few if any of the typical life-sustaining facilities or elements of infrastructure upon which much of humanity is presently highly dependent. In particular, the apparatus offers greatest benefits to persons who are suddenly and unexpectedly forced to dwell in regions of the world in which basic food preparation facilities, potable water systems, or other critical elements of the local infrastructure have been either destroyed or otherwise rendered inoperable, whether as a result of war, natural disaster, or other crisis. Under such circumstances, it should be noted that the efficacy with which emergency supplies and temporary infrastructure can be reestablished within the disaster area directly affects the quality of life and, more importantly, the survival rate of the persons located in the affected region. Ultimately, to alleviate as much general hardship as possible, but also to minimize the mortality rate, substitute temporary-use facilities need to be reestablished throughout the affected region in sufficient quantities, and with a minimum of time, effort, and expense. Due to its low cost, ease-of-use, and high degree of portability, the multifunction device disclosed herein is ideally and uniquely suited to facilitate such emergency or disaster relief efforts. As a result, the instant invention provides a highly effective method for meeting this unending global need—an aspect of the invention that is neither contemplated nor anticipated by prior art.

[0060] The present invention can also be of great benefit to individuals living, working, or traveling in underdeveloped or neglected parts of the world. For the outdoorsman or explorer, the modular field-deployable apparatus can serve as an invaluable multifunctional survival tool. In addition, as noted above, the apparatus can offer many benefits to persons who choose to participate in a variety of outdoor recreational activities for which portable food preparation facilities and/or other functions of the present invention are either needed or desired. Further, it should be noted that the highly economical apparatus is ideally suited for use as an instructional aide for teaching students or other interested parties about solar energy. Considering the world's dwindling supply of fossil fuels and other conventional fuels—especially in conjunction with the present ever-increasing global demand for energy—worldwide education about solar energy is becoming increasingly necessary to protect the environment, sustain the global economy, and ensure a reasonable quality of life for all creatures inhabiting the Earth. Once again, these additional purposes and benefits are neither contemplated nor anticipated by prior art.

[0061] As one reads subsequent sections of this document, it will become quite clear that the modular field-deployable apparatus is also superior to the related art in a variety of

other ways including, among other items, various novel methods of manufacturing, deploying, and using the modular apparatus.

[0062] c. Specific Objects and Advantages of the Invention:

[0063] Accordingly, it is a principal object of the present invention to provide a highly portable (i.e., inflatable or otherwise collapsible), multifunction, multipurpose, field-deployable apparatus and fabrication methods thereof, which is generally optimized for use as a substantially parabolic reflector to focus electromagnetic energy from radio frequency radiation (RF) through ultraviolet radiation (UV) including solar radiation (or a predetermined subset thereof), but which typically can also be used for numerous other electromagnetic and/or non-electromagnetic utilities. Regarding the multi-functional nature of this invention, specific (but optional) objects of the present invention are:

[0064] (a) to provide a highly portable multifunction apparatus for concentrating broad-spectrum (e.g., solar) radiation for cooking, heating, sterilizing, distilling, material processing, and/or for other purposes requiring or benefiting from the application of radiant heat, which may optionally utilize various accoutrements specially configured for absorbing concentrated solar radiation including, for example, a solar oven or autoclave having a high-emissivity (generally blackened) energy-absorbing external surface;

[0065] (b) to provide a portable multifunction apparatus for generating electrical power utilizing turboelectric, thermoelectric, and/or photoelectric devices;

[0066] (c) to provide a portable multifunction apparatus which can be utilized to concentrate light radiating from a relatively dim source, such as a street lamp, to operate (and/or recharge) an otherwise inoperable, low-power, photovoltaic device, such as a handheld calculator;

[0067] (d) to provide a portable multifunction apparatus which can be used for enhancing or enabling radio, microwave, and/or satellite communications (including use of one or more apparatus as a relay station), and/or for enabling radio-telescopy;

[0068] (e) to provide a portable multifunction apparatus for enhancing vision in darkened environments by concentrating visible light radiating from a dim source, such as a crescent moon, onto an object to be viewed;

[0069] (f) to provide a portable multifunction apparatus for enhancing vision in darkened environments by projecting light from non-collimated sources, such as a candle, into dark environments;

[0070] (g) to provide a highly portable multifunction apparatus for enabling or enhancing optical signal communications, such as when used with a non-collimated light source held at the focal point to form a signal beacon, and optionally further including colored, textured, polarized, and/or image containing transparent and/or reflective membrane(s) to enhance signaling and/or to provide artistic lighting or imaging;

[0071] (h) to provide a portable multifunction apparatus employing a waveguide system to capture and deliver pan-chromatic visible light (or other useful spectral range of radiation) to interior, subterranean, and/or underwater environments to enhance vision and/or to operate equipment such as an optical image projector;

[0072] (i) to provide a portable multifunction apparatus which can serve as a multi-layer emergency thermal blanket, electrostatic insulator, and/or electromagnetic energy shield to protect a person or object, but which also allows a person or object to hide from an infrared (IR) camera or otherwise be shielded from an electromagnetic imaging or detection device;

[0073] (j) to provide a portable multifunction apparatus which can serve as a soft, compliant support for persons or objects, including use as a bed, cradle, seat, inflatable cast (for immobilizing a broken limb), or the like;

[0074] (k) to provide a portable multifunction apparatus which can be used as a water flotation device, boat, or-snow sled;

[0075] (l) to provide a portable multifunction apparatus which-can be used to capture, store, process, and/or distribute water, other liquids, and/or certain solid materials, for which various optional accoutrements (such as catchment rings, gutters, funnels, filters, tubes, valves, pumps, and the like) can be either integrally or removably incorporated into the apparatus;

[0076] (m) to provide a portable multifunction apparatus incorporating a high-emissivity surface, such as a matte black surface, which can be used to collect water at night by radiative condensation processes;

[0077] (n) to provide a portable multifunction apparatus which can be used as a fermentor, which in conjunction with the distillation function noted above, allows the apparatus to produce high grade spirits for fuel, medicinal, and other purposes;

[0078] (o) to provide a portable multifunction apparatus for the directional amplification of sound;

[0079] (p) to provide a portable multifunction apparatus optionally incorporating one or more pressure-deformable, planar, reflective membranes to allow the device to have a variable focal length;

[0080] (q) to provide a portable multifunction apparatus which can be used as thermal shelter, incubator, hydrophobic growing chamber, greenhouse, frost shield, and/or general shelter from inclement weather or other environments elements (e.g., mosquitoes, other biting insects, dust, debris, sunlight, etc.);

[0081] (r) to provide a portable multifunction apparatus which can be used as dehydrator, dryer, curing chamber, and/or sealed or vented work chamber;

[0082] (s) to provide a portable multifunction apparatus which can be used as an optionally camou-

flaged wildlife viewing/hunting blind, animal cage, terrarium, aquarium, and/or aquatic growth chamber;

[0083] (t) to provide a portable multifunction apparatus which can be used as wind turbine to produce electrical and/or mechanical power; and/or

[0084] (u) to provide a portable multifunction apparatus optionally incorporating one or more one-way valves to facilitate or enable use of the apparatus as a fluid pump.

[0085] A second main object of the invention is to provide a multifunction apparatus which optionally is extremely lightweight, fully collapsible, and compactly foldable so as to greatly facilitate portage and storage, thereby providing a high performance apparatus which is ideally suited to camping, backpacking, picnicking, boating, emergency use, disaster relief, and/or other situations (terrestrial or space-based) for which high mass-specific and/or high volume-specific performance is critical. Regarding portage and storage, specific (but optional) objects of this invention are:

[0086] (a) to provide a multifunctional apparatus having a primary structure comprised entirely of thin and/or very thin, high-strength membranes to minimize weight;

[0087] (b) to provide a multi-functional apparatus which is inflatable (i.e., rigidizable and/or otherwise deployable) by using pressurized gas which generally need not (but may) be carried with the device;

[0088] (c) to provide a multifunctional apparatus which is fully collapsible and compactly foldable when not in use to minimize volume;

[0089] (d) to provide a multifunctional apparatus which, due to its extremely low weight and stored (non-deployed) volume, yields very high mass-specific and volume-specific performance approximating 10000 watts per kilogram and 10 megawatts per cubic meter, respectively, when used terrestrially as a broad-spectrum solar concentrator; and/or

[0090] (e) to provide a multifunctional device having extremely lightweight and compact inflation valves, for example, valves made from membranous material and including an interlocking tongue-and-groove (i.e. "Ziploc"-type), clamped or tied, or self-sealing type closure mechanism.

[0091] A third main object of the invention is to provide a multifunctional apparatus which optionally is safer to operate, transport, and/or store. Regarding safety, specific (but optional) objects of this invention are:

[0092] (a) to provide a portable multifunctional apparatus having an integral safety cage (preferably inflatable or otherwise fully collapsible) which forms a physical barrier around the focal point, thereby preventing accidental exposure to potentially dangerous concentrations of electromagnetic radiation;

[0093] (b) to provide a portable multifunctional apparatus having an integral safety cover to block radiation from striking the reflective membranes when the device is not in use, thereby preventing the formation of and, thus, the risk of accidental exposure to

potentially dangerous concentrations of electromagnetic radiation at or near the focal point;

[0094] (c) to provide a portable multifunctional apparatus having an integral reflector wrinkling mechanism for distorting the reflective membranes when not fully deployed (pressurized), thereby once again substantially preventing the formation of any unintentional, potentially dangerous concentrations of electromagnetic energy;

[0095] (d) to provide a portable multifunctional apparatus having one or more preformed parabolic reflective membranes, which limit the device to substantially fixed, short focal lengths, thereby enhancing safety by giving the operator greater control of the location of the highly concentrated energy at the focal point;

[0096] (e) to provide a portable multifunctional apparatus having one or more pre-formed, non-parabolic reflective membranes to limit the maximum degree of energy concentration to lower and, thus, safer levels;

[0097] (f) to provide a portable multifunctional apparatus having one or more means for off-axis light attenuation such as, for example, an off-axis light attenuation grating for attenuating power when device is positioned off-axis, and/or a darkened transparent film for attenuating reflected light when viewing from a position substantially off-axis;

[0098] (g) to provide a portable multifunctional apparatus having one or more means for blocking and/or redirecting energy in proximity focal point so as to provide a quick power shutoff means and/or to capture and redirect stray electromagnetic rays (which also can improve performance); and/or

[0099] (h) to provide a portable multifunctional apparatus having redundant inflatable (or otherwise collapsible) support structures (e.g., independent pressure envelopes) to mitigate the risk of catastrophic collapse or other failure.

[0100] A fourth main object of the invention is to provide a portable multifunctional apparatus that optionally is easier to deploy and/or operate. Regarding ease of use, specific (but optional) objects of this invention are:

[0101] (a) to provide an apparatus having various integral securing and storage features such as handles, apertured tabs, ties, weighting and storage pouches (especially those which are lightweight, compact, and can be made from extensions of the membranes out of which the apparatus is composed);

[0102] (b) to provide an apparatus having various integral accessory hardware attachment devices such as devises, clips, brackets, sockets, hook-and-loop patches, and other common fastening mechanisms (especially those which are collapsible to facilitate portage and storage);

[0103] (c) to, provide an apparatus having various lightweight, portable mechanisms for supporting and orienting the device including, for example, an inflatable adjustable dipody support, a stack of inflat-

able tapered support/leveling rings, and/or an inflatable (or otherwise collapsible) spherical mounting element with a separate, optionally inflatable (floating), support ring;

[0104] (d) to provide an apparatus having light-weight, portable mechanisms for holding various items and/or accoutrements at or near the focal point including, for example, a collapsible, multipurpose rotisserie/kettle support, a collapsible multi-leg focal point support, and/or an inflatable focal point support;

[0105] (e) to provide an apparatus having one or more pre-formed, pressure-deformable reflective membranes, which can be fully deployed using significantly lower differential pressures across the membranes than devices employing planar reflective membranes, thus facilitating proper inflation;

[0106] (f) to provide an apparatus having integral or removably attached orientating and alignment features, such as a visual alignment guide, inclinometer, level, and/or magnetic compass, to facilitate alignment with an electromagnetic source and/or target, and/or for orienting the device for other purposes;

[0107] (g) to provide an apparatus having a light/heating intensity controller such as a louver or iris mechanism which is manually or automatically controlled;

[0108] (h) to provide an apparatus having various integrally or separately attached electronic and/or mechanical elements to facilitate various applications including but not limited to photovoltaic cells, electrical batteries, electric pumps, fans, drivers, timers, thermostats, controllers, and/or other useful devices; and/or

[0109] (i) to provide an apparatus having a light-weight means for automated sun tracking.

[0110] A fifth main object of the invention is to provide a portable multifunctional apparatus which optionally is more efficient, wherein two pressure deformable membranes, are utilized to form a sub-ambient concave-concave reflector chamber configuration, thereby eliminating the plurality of losses inherent in devices having one or more intervening layers in the optical path, such as a transparent membrane of a super-ambient reflector chamber, through which light must pass at least once on its way to or from the focal point.

[0111] A sixth main object of the invention is to provide a portable multifunctional apparatus which optionally is highly economical by virtue of its extremely simple, highly integrated construction, and which can thus be made universally available for both routine use as well as educational purposes. Regarding economy, specific (but optional) objects of this invention are:

[0112] a) to provide a basic reflector apparatus (first and/or second main embodiment) made from a plurality of (generally four or more) sheets of thin, high-strength, high-elastic-modulus (preferably), commercially available material(s), plus the necessary valves, using a substantially flat pattern fabrication method that greatly simplifies manufacturing tooling and processing, thereby reducing fabrication cost;

[0113] (b) to provide a basic reflector apparatus (second embodiment) which can be fabricated from as few as two thin sheets of high-strength, commercially available material (s), plus the necessary valves, using simple, well-established manufacturing processes; and/or

[0114] (c) to provide a modular field-deployable apparatus, wherein one or more of its modules (or components thereof) are sized to substantially match (i.e., have the same size as) other modules (or components thereof), so as to reduce fabrication cost by minimizing the number of different elements that need to be produced (but also to enhance versatility and facilitate repair).

[0115] A seventh main object of the invention is to provide a portable multifunctional apparatus that is optionally highly drop tolerant, otherwise damage tolerant, and easy to repair in the event of damage. Regarding damage tolerance and reparability, specific (but optional) objects of this invention are:

[0116] (a) to provide an apparatus having one or more redundant reflector chambers such that if one reflector chamber is damaged, the device is still operable;

[0117] (b) to provide an apparatus constructed primarily of highly flexible materials (optionally including multi-layered and/or fiber-reinforced composite materials which are puncture-resistant, tear-resistant, and/or abrasion resistant) such that the apparatus can be dropped intentionally (e.g. air dropped), dropped unintentionally (i.e. accidentally), and/or otherwise be subjected to harsh operating conditions yet sustain no appreciable damage; and/or

[0118] (c) to provide an apparatus having integral quick-repair materials (e.g., self-adhesive patches and the like).

[0119] An eighth main object of the invention is to provide a portable multifunctional apparatus that is highly environmentally friendly by virtue of the fact that the apparatus generally requires no fuel to operate. Instead, the instant invention typically relies solely on radiating solar energy when used for heating, cooking, and the like, thereby minimizing air, water, and ground pollution. This is in stark contrast to other common portable cooking and heating equipment, which generally rely on the combustion of hydrocarbon fuels and, thus, inherently cause pollution through both combustion processes and unintentional fuel releases (e.g. spills, leaks, vapor releases, and the like).

[0120] It is a further object of the invention to provide improved elements and arrangements thereof for the purposes described which is inexpensive, dependable, and fully effective in accomplishing its intended purposes.

[0121] These and other objects of the present invention will become readily apparent upon further review of the following specification and drawings. However, it is once again emphasized that any particular embodiment or manifestation of the present invention need not perform all such functions or otherwise meet all such objects of the present invention as noted herein, thus prompting the use the term "optional" and/or "optionally" when referring to the various objects of the invention in several of the preceding para-

graphs. Specifically, any particular embodiment of the present invention can be configured to perform and/or meet only a limited number (or subset) of these functions and/or objects without departing from the basic nature of the invention.

BREIF DESCRIPTION OF FIGURES

[0122] FIGS. 1A-C are, respectively, a perspective view, a side elevation cross-sectional view, and an exploded cross-sectional view of a typical modular, inflatable, multi-function, field-deployable apparatus.

[0123] FIGS. 2A-B are, respectively, a top plan view and a side-elevation view of the basic inflatable reflector apparatus in a currently preferred first embodiment configuration.

[0124] FIG. 2C is a perspective view of the basic inflatable reflector apparatus showing various optional attachment means for attaching other modules, for connecting other accessory elements, and/or for securing the apparatus as exemplary of the various attachment means which also may be included in the other modules.

[0125] FIGS. 3A-3B are schematic cross-sectional views of the basic first embodiment reflector apparatus being used to concentrate and project, respectively, radiant electromagnetic energy with its reflector chamber deployed in sub-ambient mode.

[0126] FIGS. 3C-F are schematic cross-sectional views of the basic first embodiment reflector apparatus being used to manipulate radiant electromagnetic energy with its reflector chamber deployed in super-ambient mode.

[0127] FIGS. 4A-B are, respectively, a top plan view and a side-elevation view of the basic inflatable reflector apparatus in a second embodiment configuration.

[0128] FIGS. 4C-I are diametrical cross-section views of the basic inflatable reflector apparatus in a second embodiment configuration illustrating the operation of various preferred and alternate reflector chamber configurations.

[0129] FIGS. 5A-C are, respectively, a perspective view, a diametrical cross-sectional view, and a partial cross-sectional view of a modified basic first embodiment reflector apparatus having a removably attached central pressure-deformable membrane.

[0130] FIGS. 6A-B are, respectively, schematic diametric cross-sectional views of alternate first and second embodiment reflector apparatuses having a removably attached reflector chamber.

[0131] FIGS. 6C-D are partial schematic diametric cross-sectional views of a typical attachment means for securing a removably attachable reflector chamber to the toroid.

[0132] FIGS. 7A-B are schematic diametric cross-sectional views of alternate basic first embodiment reflector apparatuses having detuned (i.e., non-parabolic) reflective membranes which are pre-formed, respectively, into spherical and non-spherical surfaces-of-revolution.

[0133] FIGS. 8A-B are, respectively, a schematic top plan view and a schematic diametric cross-sectional view of an alternate basic first embodiment reflector apparatus having a detuned reflective membrane pre-formed into the shape of a radially undulating (or radially stepped) surface of revolution.

[0134] FIGS. 9A-D are schematic top plan views and schematic diametric cross-sectional views of alternate basic first embodiment reflector apparatuses having a detuned reflective membrane pre-formed into the shape of a radially undulating (or radially stepped) surface of revolution.

[0135] FIGS. 10A-B are a schematic top plan view and schematic diametric cross-sectional view of an alternate basic first embodiment reflector apparatus having a detuned reflective membrane comprising a plurality (e.g., twelve) of pre-formed, wedge-shaped dimples optionally supported by an underlying radial support grid (i.e., a plurality of radial cords, wires, cables, or the like).

[0136] FIGS. 11A-H are several schematic top plan views and a schematic diametric cross-sectional view of alternate basic first embodiment reflector apparatuses having a detuned reflective membrane comprising a plurality of pre-formed dimples in substantially hexagonal, circular, annular, or rectangular arrays, optionally supported by an underlying support grid.

[0137] FIGS. 12A-D are schematic top plan views and schematic diametric cross-sectional views of alternate basic first embodiment reflector apparatuses having a detuned reflective membrane comprising a plurality of generally wedge-shaped facets.

[0138] FIGS. 13A-D are schematic top plan views and schematic diametric cross-sectional views of alternate basic first embodiment reflector apparatuses having a detuned composite reflective membrane comprising a plurality of conical facets.

[0139] FIGS. 14A-F are several schematic top plan views and a schematic diametric cross-sectional view of alternate basic first embodiment reflector apparatuses having a detuned composite reflective membrane comprising a plurality of substantially planar facets in substantially circular, annular, or triangular arrays.

[0140] FIGS. 15A-B are a schematic top plan view and a schematic diametric cross-sectional view of an alternate basic first embodiment reflector apparatus having a detuned faceted reflective membrane which is alternately deployed via a plurality of internal ribs of sheets bonded to an opposing membrane.

[0141] FIGS. 16A-B are a schematic top plan view and a schematic diametric cross-sectional view of an alternate basic first embodiment reflector apparatus having a detuned reflective membrane, wherein a central inflatable pressure envelop is disposed between the upper and lower pressure-deformable membranes to mildly distort the reflective membrane.

[0142] FIGS. 17A-B are a schematic top plan view and a schematic diametric cross-sectional view of an alternate basic first embodiment reflector apparatus having a dual-focal-point, detuned reflective membrane resulting in a device having two useable focal points.

[0143] FIGS. 18A-D are schematic cross-sectional views of the modular multi-function apparatus being used as a broad-spectrum electromagnetic (e.g., solar) energy concentrator for cooking, heating, energizing, and the like.

[0144] FIGS. 19A-D are schematic cross-sectional views of the modular multi-function apparatus being used as a high-gain antenna to facilitate or enable electronic communications.

[0145] FIGS. 20A-D are schematic cross-sectional views of the modular multi-function apparatus being used to manipulate visible-spectrum radiation (i.e., light) to enhance vision, communicate by light signals, and the like.

[0146] FIGS. 21A-D are schematic cross-sectional views of the modular multi-function apparatus being used as a compliant support, shelter, and the like.

[0147] FIGS. 22A-C are schematic cross-sectional views of the modular multi-function apparatus being used as a water collection, storage, and processing apparatus.

[0148] FIGS. 23A-N are schematic cross-sectional views, front elevational views, and side elevational views of the modular multi-function apparatus being used as part of a wind turbine apparatus for generating mechanical and/or electrical power.

[0149] FIGS. 24A-D are schematic cross-sectional views of the modular multi-function apparatus being used for miscellaneous functions, including, respectively, use as a high-gain directional sound-amplification device, use as a fermentation apparatus, use as a sieve or filter, and use as a floating aquatic chamber.

[0150] FIGS. 25A-D are schematic cross-sectional views of the modular multi-function apparatus illustrating alternate methods of constructing the inflatable spherical support and the inflatable safety shield.

[0151] FIG. 26 is a schematic cross-sectional view of an alternate modular inflatable multi-function apparatus comprising a reflective membrane integrated with low-inflation-volume combination spherical support and focal point support.

[0152] FIGS. 27A-D are schematic perspective views illustrating various alternate safety cages (i.e., truss-like safety shields with optional safety nets).

[0153] FIGS. 28A-D are schematic cross-sectional views a basic inflatable reflector apparatus being supported by a plurality of inflatable tapered support and leveling rings.

[0154] FIGS. 29A-D are schematic perspective views illustrating various alternate combination/dual-use safety cages and device supports.

[0155] FIGS. 30A-B are schematic perspective views illustrating various alternate combination/dual-use safety cages and device supports.

[0156] FIGS. 31A-D are a schematic perspective views and three schematic cross-sectional views illustrating various alternate collapsible combination safety cage and device supports shown supporting removable reflector chambers.

[0157] FIGS. 32A-H are schematic perspective views illustrating various alternate cable-stayed focal point support.

[0158] FIGS. 33A-B are schematic cross-sectional views illustrating the use of a waveguide with a super-ambient-pressure first embodiment basic reflector apparatus.

[0159] FIGS. 34A-D are schematic cross-sectional views illustrating the use a basic first embodiment reflector apparatus as a fluid pump.

[0160] FIGS. 35A-E are schematic perspective views and schematic cross-section views illustrating the use of additional accessory membranes for both enhanced water collection and use as a shelter.

[0161] FIG. 36 is a schematic perspective view of a modified first embodiment reflector apparatus further including optional accessory elements, such as a peripheral gutter, for facilitating the collection and storage of water.

[0162] FIG. 37 is a schematic perspective view of a modified first embodiment reflector apparatus configured as a portable sealed work chamber.

[0163] FIGS. 38A-B are schematic perspective views of a modified first embodiment reflector apparatus further including self-supporting single-axis and dual-axis means for tracking the sun.

[0164] FIGS. 39A-C are schematic perspective views of a modified first embodiment reflector apparatus further including suspended single-axis and dual-axis means for tracking the sun.

[0165] FIGS. 40A-D are schematic perspective views of a typical, substantially polymeric, multi-layer, composite materials from which the apparatus can be constructed.

DETAILED DESCRIPTION

[0166] FIGS. 1A-C: Modular Inflatable Multifunction Apparatus

[0167] FIG. 1A depicts a typical modular, inflatable, multifunction, field-deployable apparatus _____ comprising as its primary functional element a basic inflatable multifunction reflector apparatus _____ in a preferred first embodiment configuration, which is supported on its lower side by a removably attached inflatable spherical support _____ movably couched within a separate inflatable toroidal ring _____, and which supports on its upper side a removably attached inflatable safety shield _____ or cage that further supports a removably attached cable-stayed support _____ for holding various materials and/or accessory elements _____ in proximity to the focal point _____ of the basic reflector apparatus.

[0168] In addition to the safety shield _____, two other safety means are shown for protecting the user from accidental exposure to potentially dangerous, high concentrations of electromagnetic energy at or near the focal point. First, a removably attached inflatable protective safety cover _____ is shown attached to the upper portion of the safety cage _____ in a deployed (inflated) condition. The protective safety cover can be quickly deployed to either attenuate the amount of electromagnetic energy striking the reflector _____ when the apparatus is being used, or to fully block such electromagnetic radiation when the apparatus is not in use. Second, a protective safety net or mesh _____ is shown attached to the upper portion of the safety shield _____ to restrict non-deliberate physical access to the focal point. Note that the safety net _____ also can be used to provide a convenient support for a partially or fully deployed safety cover _____, and to structurally stabilize or reinforce the upper end of the safety shield _____.

[0169] Additionally, safety is further enhanced by a plurality of stabilizing cables _____ or lines, which are shown connecting the movable upper portion of the modular appa-

ratus to the surface (e.g., ground) upon which the lower support ring _____ of the apparatus _____ is resting.

[0170] Regarding physical construction, briefly note that each module of the apparatus typically is principally constructed from one or more thin flexible (e.g., pressure deformable) membranes, one or more lightweight inflatable structures, and/or other flexible structural elements, such as cables, lines, nets, and the like. In addition, each of the inflatable and/or otherwise pressure-deployable modules contains one or more inflation or pressure adjusting means such as the simple plug-type valves _____ as shown; however, a variety of other well-known inflation or pressure adjusting means may be employed including, for example, manual or automatic pumps, pressurized gas canisters, and the like. Further, to enable the various modules of the modular apparatus to operate as a unit, each module typically includes one or more attachment means _____ for attaching the module to other modules, for attaching accessory elements, and/or for securing and stabilizing the apparatus as noted above.

[0171] FIG. 1B depicts the modular field-deployable apparatus _____ shown in cross-section concentrating radiant electromagnetic rays _____ (e.g., solar radiation), to heat an energy-absorbing accessory element _____, such as a pot, kettle, oven, and the like, suspended in proximity to the focal point _____ via a cable-stayed support _____. Note that the movable upper portion of the modular apparatus is positioned or couched within in the lower support ring to substantially align the focal axis _____ of the basic reflector module _____ with the incoming solar radiation _____. The safety cover _____ is shown partially deployed and secured with ties _____ (or other attachment means), thereby providing an adjustable means for attenuating (i.e., reducing) the amount of concentrated radiant energy impinging upon the element held in proximity to the focal point.

[0172] FIG. 1C depicts an exploded cross-sectional view of the modular field-deployable apparatus _____ illustrating in greater clarity its primary modules and their basic physical constructions. Such modular construction allows the apparatus to be readily reconfigured by the user in the field to perform other user-selected functions, as will be shown hereinbelow. Further, such modular construction enhances safety by providing redundant structures, thereby effectively mitigating the risk of catastrophic collapse of the apparatus.

[0173] It should be noted that each of the primary modules of apparatus _____ may optionally comprise a plurality of user-selected, user-detachable sub-modules. For example, as shown hereinbelow, the basic reflector apparatus _____ may alternatively have one or more removable central membranes and/or a removable reflector chamber to increase versatility of the basic reflector apparatus _____ and/or modular apparatus _____. As another example, the inflatable safety cage module _____ is shown as having a plurality (e.g., three) of removably attached, individually inflated, toroidal rings. This multi-ring configuration also promotes versatility in that the rings can be separated and/or alternately combined with other elements of the apparatus to serve other functions, for example, use as water flotation devices. Note that the use of multiple, separately inflated rings for the safety shield also provides an effective means for mitigating the risk of rapid catastrophic collapse.

[0174] It should be further noted that the various modules and/or components thereof (i.e., sub-modules) are shown preferably sized, where possible, to substantially match the size of one or more other modules and/or components of the present apparatus, both to reduce fabrication cost, and to permit similarly sized modules or components to be easily interchanged to increase versatility and/or facilitate maintenance.

[0175] The invention also contemplates that one or more of the primary modules of the overall modular apparatus may be integrally attached and, optionally, simultaneously-inflated by providing interconnecting gas ports between the integrally attached modules. Although such integration and interconnection may reduce structural redundancy, safety may nonetheless be enhanced, for example, by causing the safety shield be deployed simultaneously with the reflector apparatus. The invention further contemplates various alternate configurations for each of its primary modules, several examples of which will be shown hereinbelow.

[0176] FIGS. 2A-C Description of the Basic Inflatable Reflector Apparatus—First Embodiment

[0177] FIGS. 2A and 2B depict a currently preferred first embodiment configuration of the basic inflatable reflector apparatus 10, which is illustrated as an inflated toroid or ring support element 12 having a circular cross-section and supporting an upper frontal reflective membrane 14 and a lower transparent reflective membrane 16. The two central reflective membranes 14, 16 in conjunction with the inner portion of the toroidal ring support element 12 provide a central reflector chamber (i.e. pressure envelope) 20 with a double parabolic, concave-concave configuration when inflated to a sub-ambient pressure, i.e. deployed in sub-ambient mode. The membranes 14, 16 each have a centered inflation valve 18 as an example of a pressure-adjusting or inflation means for inflating the reflector chamber 20. The inflatable toroidal ring support element 12 also has a valve 18 as an example of an inflation means for inflating the ring support element to form a rigid ring. It should be noted that by utilizing the inner portion of the ring support element as an integral part of the reflector chamber, the first embodiment device 10 can be manufactured very economically from a minimum number of pieces.

[0178] The toroidal ring support element 12 is fabricated from two sheets 13, which are substantially flat and annular prior to inflation, and which are adhesively or thermally bonded to each other along continuous seams 22 at their inner and outer periphery to form a toroid upon inflation, as one example of forming the toroid. The two sheets 13 comprising the toroid 12 are made of a high-strain-capable material, i.e., a material having high strength and low elastic modulus, such as vinyl, which is necessary for allowing the inner portion of a toroid fabricated from flat annular sheets to strain (i.e., stretch) sufficiently so as not to impede full inflation of the toroidal ring support element 12.

[0179] The central pressure-deformable membranes 14, 16 are made from thin circular sheets of high-strength, flexible material such as nylon or Mylar®, a polyethylene terephthalate plastic composition. Reflective surface 24 is provided by preferably coating the outer side of the membrane 14 with vapor deposited aluminum and the like reflective material. The reflective membrane 14 is thermally or otherwise pre-formed during fabrication into the shape of

a paraboloid to provide a short, fixed focal length for safety purposes and to reduce the differential pressure required to fully deform and smooth the reflective membrane **14**, thus facilitating deployment as well as reducing the loads imposed on the support ring by the reflective membrane (mechanical loads) and the reflector chamber (pressure loads). The transparent membrane **16** optionally may also be preformed to reduce the load it imposes on the support ring. Seams **22** are shown for adhesively or thermally bonding the periphery of the central membranes **14**, **16** to the toroid **12** at or near what will become circular lines of tangency between the central membranes **14**, **16** and the toroidal ring support element **12** upon inflation.

[0180] Numerous alternate toroid configurations can be incorporated (i.e., substituted) into the basic first embodiment device as described above. FIG. 2A shows that the toroidal ring support element **12** has a circular planform; however, it is noted that the invention can be practiced using other types of supports including those having hexagonal, square, rectangular, elliptical, and other planforms. (Note that planforms having at least one substantially linear peripheral edge may prove useful for orienting and/or stabilizing the apparatus.) Furthermore, the simple two-sheet construction of the toroid as described above may be replaced with various alternate toroidal ring support elements offering greater performance and stability but generally at the expense of somewhat greater complexity. For example, the toroid optionally may be fabricated from a plurality (e.g., generally four or more) flat annular sheets of high modulus material, such as described in our previous (cross-referenced) applications, which also describe several other alternate configurations. Additionally, it should be noted that the invention is not intended to be limited to the specific materials and/or configurations as specified above for the toroid. Depending on the configuration, the toroid can be made from any suitably flexible material, including various other substantially polymeric material's, including monolithic, layered, and/or fiber-reinforced composite material.

[0181] Similarly, numerous alternate central pressure-deformable membrane configurations can be incorporated (i.e. substituted) into the basic first embodiment device as described above. For example, the invention can be practiced using planar (i.e. non-pre-formed) pressure-deformable reflective membranes to yield a device capable of providing a variable focal length as a function of the differential pressure imposed across the reflective membrane **14**. Furthermore, the use of pre-formed, non-parabolic reflective membranes (e.g. reflective membranes having surfaces which are spherical, undulating, dimpled, faceted, or which comprise a series of conic sections, and the like) is contemplated to limit the maximum degree of concentration to further enhance safety and/or to provide more uniform heating. The invention can also employ a redundant reflective membrane such as described in our previous cross-referenced applications (e.g., the transparent membrane can be replaced with a reflective membrane to provide a second reflector having optionally similar or significantly different optical properties, such as focal length). It should be noted that the invention is not intended to be limited to the specific materials and/or configurations as specified above for the central pressure-deformable membranes. Similar to the toroid, depending on the configuration, the central membranes can also be made from any suitably flexible material, for

example, other substantially polymeric materials, including monolithic, layered, and/or fiber-reinforced composite materials. Additionally, the reflective surface can be provided by a plastic reflective membrane, which alternatively has reflective particles homogeneously incorporated, or which contains an integral conductive wire or mesh, all of which tend to selectively reflect or filter the impinging radiation. Also, the device may optionally incorporate membranes having other arbitrary but useful optical properties such as selective transparency, translucency, opacity, color, texture, and/or polarization for practical and/or artistic applications.

[0182] Regarding valves, note that the pre-formed pressure-deployable central membranes are shown as having a funnel-shaped region surrounding the centered inflation valve to facilitate fluid collection. Membranous valves may also be employed, including those having self-sealing means such as used in toy balloons, or Ziploc® type tongue-and groove sealing means.

[0183] To fully deploy the basic first embodiment device **10** in sub-ambient mode as shown in FIGS. 2A and 2B, the device, which is typically compactly folded for portage and storage, is first unfolded to gain access to the inflation valves **18**. Subsequently, the toroidal ring support element **12** is inflated to a super-ambient pressure to rigidize the ring support element **12** as is necessary to properly support and tension the central membranes **14**, **16**. The reflector chamber **20** is then inflated to a sub-ambient pressure (as is required for most applications) to deform and smooth the reflective membrane **14** into a concave substantially parabolic reflector. Finally, the focal axis of the parabolic reflective membrane is appropriately oriented toward the energy source and/or target, as required for a particular application or mode of operation. As previously noted, the first main embodiment device-**10** can also be deployed in super-ambient mode as shown later in this document.

[0184] FIG. 2C depicts a currently preferred first embodiment configuration of the basic inflatable multi-function reflector apparatus **10** further including various optional accessory attachment means for attaching other modules, for connecting other accessory elements, and/or for securing and stabilizing the apparatus. A pair of handles **32** are positioned diametrically on the sides of the toroid **12**. An apertured tab **34** is provided on a side equidistantly between the handles **32** for hanging up when in storage or the like. A pair of tying or hanging straps **36** are attached on either side of the apertured tab **34**. A storage pouch **38** is provided for storing the deflated and folded apparatus **10**. A pair of bottom pouches **40** is provided for filling with dense material to stabilize an upright apparatus **10**. It should be noted that these appendages can be incorporated into the device in any useful quantity, location, and combination thereof. It should also be noted that each of these appendages is highly amenable to fabrication from thin membrane materials to minimize size and weight to facilitate portage and storage, and that each can be fabricated fully or in part from extensions of the central membranes **14**, **16** and/or the membranes comprising the toroidal support element **12** to facilitate manufacturing.

[0185] FIG. 2C also depicts other various optional attachment devices which are generally rigid or semi-rigid, but which are preferably collapsible to facilitate portage and storage. Examples include a clevis, shackle, clip or bracket

54 for attaching various accessory elements including, for example, a support rod **56** or a line. Hook-and-loop fastening-patches **58** and a mounting stud **60** are also provided for attaching various accessory elements. A centered socket **62** is shown in the upper frontal reflective membrane **14** for supporting other accessory elements including, for example, an antenna **64**.

[0186] It should be noted that any of these attachment devices can be incorporated into the basic reflector apparatus **10** (or any other module, sub-module, and/or accessory elements of the present invention, including any alternate embodiments or configurations thereof) in any useful quantity, location, and combination thereof. Further, one or more of these attachment means may be combined or otherwise integrated with other various features of the present invention to facilitate manufacture or for other purposes. For example, an inflation valve **18** may be combined with a mounting bracket **54**, hook-and-loop fastening patches **58**, a socket **62**, or the like.

[0187] FIGS. 3A-F Operation of the Basic Inflatable Reflector Apparatus—First Embodiment

[0188] FIG. 3A depicts the first main embodiment device **10** deployed in sub-ambient mode as an electromagnetic radiant ray concentrator having the focal axis of the pre-formed parabolic reflective membrane **14** oriented toward the sun (not shown). The radiant solar rays **28** are reflected by the pre-formed parabolic reflective membrane **14** to focus on an energy-absorbing object (not shown) placed at the focal point **26**.

[0189] Regarding the instant device's ability to capture and concentrate electromagnetic radiation, it should first be noted that a device deployed in sub-ambient mode allows the electromagnetic rays to travel unobstructed to and from the reflector, thus providing superior capture efficiency relative to much of the prior art as well as the second main embodiment of the instant invention (capture efficiency is defined herein as the portion of the incoming radiant energy that is delivered to the focal point and local surrounding area). As an example, when operated in sub-ambient mode as a terrestrially-based solar concentrator as shown in FIG. 3A, the first main embodiment device has an effective capture efficiency exceeding 90%, which is limited only by the reflective efficiency of the membrane and the transmission and dispersion characteristics of the surrounding atmosphere. Second, although a reflective parabolic surface is the ideal geometry for reflecting all incoming parallel radiant rays to the focal point and, thus, producing extremely high theoretical concentrations of energy, the-ability of the instant device to concentrate energy is limited by several factors including, but not limited to, the geometric precision of the reflective membrane and, hence, its supporting toroidal ring support element, the capture efficiency of the device as noted above, the apparent finite angular diameter of the source (e.g. the sun), and the wavelength of the radiation relative to the diameter of the reflector. Despite these and other limiting factors, a precisely constructed first embodiment device used as a terrestrially-based solar concentrator has the ability to concentrate sunlight by factors in excess of 10,000.

[0190] Regarding safety, as one consequence of having a pre-formed reflective membrane **14**, the device has a fixed focal length, i.e. the focal point is located at a substantially fixed distance from the reflective membrane along the focal

axis of reflector **14**. This fixed focal length greatly enhances safety by allowing the user to maintain greater control of the location of any potentially dangerous high concentrations of electromagnetic radiation at the focal point. A second consequence of employing thermally or otherwise pre-formed reflective membranes is that pre-forming allows the reflectors to achieve significantly shorter focal lengths than is practical using non-pre-formed, planar membranes due to the limited ability of planar membranes to elastically deform. The very short focal lengths achieved by such deeply pre-formed reflective membranes further enhance safety by providing the user with even greater control over the location of the concentrated electromagnetic radiation.

[0191] FIG. 3B depicts a first main embodiment device **10** deployed in sub-ambient mode as a radiant ray projector with the same reflector structure **20** as shown in FIG. 3A, but projecting a collimated beam of the electromagnetic rays from a non-collimated light source (not shown) such as a light bulb, lamp, or candle placed at the focal point **26** to a distant object (not shown). It should be noted that the selection of the concentrating or projecting mode depends on the position of the light or other electromagnetic source relative to the focal point of the device.

[0192] It should be further noted that the focal axis of the pre-formed parabolic reflective membrane **14**, as depicted in FIGS. 3A and 3B, is coincident with the axis-of-revolution of the toroidal support element **12**, thereby causing the focal point of the device to be aligned with the axis-of-revolution of the toroid and, thus, to be located directly above the center of the reflective membrane. However, one or both of the reflective membranes **14**, **16** may be pre-formed and/or attached to the toroid support element **12** in such a manner that the focal point of the device **10** is located off the axis-of-revolution of the support ring **12**. Note that such "off-axis" reflectors can facilitate orientating the device relative to the energy source and/or target for certain applications.

[0193] FIG. 3C depicts the basic first embodiment reflector apparatus **10** being used to concentrate radiant electromagnetic energy **28** with its reflector chamber **20** alternatively deployed in super-ambient mode (i.e., the reflector chamber is inflated to a super-ambient pressure to outwardly deploy the reflective membrane). Note that central membranes **14**, **16** are pre-formed such that the focal point is located substantially at the surface of the transparent membrane **16** of the super-ambient pressurized reflector chamber **20**, thereby allowing the transparent membrane **16** to directly support a suitable electromagnetic accessory device (not shown) in proximity to the focal point.

[0194] FIG. 3D depicts a first-main embodiment device **10** deployed in super-ambient mode as a radiant ray diffuser with the same reflector structure **20** as shown in FIG. 3C, but used alternatively as a convex mirror, such as for expanding the user's field of view for surveillance or safety. More specifically, the apparatus can serve as an economical field-deployable convex mirror, which can be used, for example, to allow a vehicle operator to see around a blind corner.

[0195] FIG. 3E depicts a modified basic first embodiment reflector apparatus **10** being used to concentrate radiant electromagnetic energy with its reflector chamber **20** deployed in super-ambient mode, wherein the central mem-

branes **14, 16** are pre-deformed such that the focal point **26** is located within the super-ambient pressurized reflector chamber **20**.

[0196] FIG. 3F depicts a modified basic first embodiment reflector apparatus **10** being used to concentrate radiant electromagnetic energy with its reflector chamber **20** deployed in super-ambient mode, wherein the central membranes **14, 16** are pre-deformed such that the focal point **26** is located outside the super-ambient pressurized reflector chamber **20**.

[0197] FIGS. 4A-I Description and Operation of the Basic Inflatable Reflector Apparatus—Second Embodiment

[0198] In FIGS. 4A and 4B, the second main embodiment device **386** is illustrated as an inflated toroid or ring support element **400** supporting an upper transparent membrane **388** and a lower reflective membrane **390**. The transparent membrane **388** and reflective membrane **390** provide a central reflector chamber (i.e. pressure envelope) **392** with a double parabolic convex-convex lens configuration when inflated to a super-ambient pressure. The transparent membrane **388** has a centered inflation valve **18** for inflating the reflector chamber **392**; however, it is noted that the inflation valve **18** may alternatively be located at any other useful location such as in the reflective membrane **390**. The inflatable toroidal support element **400** also has a valve **18** for inflation to form a rigid ring. Two valves are shown for separate inflation of the ring support **400** and the reflector chamber **392**; however, it is noted that the two pressure envelopes (the toroid **400** and the reflector chamber **392**) can be interconnected, thereby allowing both super-ambient pressure envelopes to be inflated with a single valve **18**.

[0199] The toroidal support element **400** is fabricated from two thin sheets **401** of material, each of which is fully pre-formed into the shape of a half toroid and adhesively or thermally bonded to each other along continuous seams **22** at their inner and outer periphery, as one example of forming the toroid. The two sheets **401** comprising the toroid **400** are made of a flexible, high-strength material capable of being thermally or otherwise pre-formed, such as vinyl, nylon, and the like.

[0200] The transparent membrane **388** is made from a thin circular sheet of transparent, high-strength, flexible material such as Mylar® or Nylon. The reflective membrane **390** is also made from a thin circular sheet of high-strength, flexible material such as Mylar® or Nylon; however, a reflective surface **24** is provided by coating the inner side (preferred, but not necessary if the uncoated membrane material is otherwise transparent) of the membrane **390** with vapor deposited aluminum and the like reflective material. The reflective membrane **390** is pre-formed during fabrication substantially into the shape of a paraboloid to provide a substantially fixed, short focal length for safety purposes, and to reduce the differential pressure required to fully deform and smooth the reflective membranes **390** to facilitate deployment. The transparent membrane **388** is optionally also pre-formed, primarily to reduce loads imparted on the support ring; however, the transparent membrane **388** also can be pre-formed for other purposes, such as to facilitate supporting an accessory element in close proximity to the focal point as will be shown below. However, the transparent membrane need not be pre-formed (or it can be pre-formed to a different extent than the reflective mem-

brane), thus yielding an asymmetrical reflector chamber. Seams **22** are shown for adhesively or thermally bonding the outer periphery of the reflective and transparent membranes **388, 390** to the inner edge of the toroid **400**. This basic, four-sheet, fully pre-formed construction represents a first species **398** of the second main embodiment device **386**.

[0201] Similar to the first embodiment, it should be noted that several alternate toroid, central membrane, and valve configurations can be incorporated (i.e. substituted) into the basic second embodiment device as described above. In addition to having alternate plan forms, the simple two-sheet toroidal support element **400** as described above may be replaced with alternate support rings offering greater performance and/or stability, but generally at the expense of somewhat greater complexity. However, such alternate support ring configurations for the second embodiment are limited to those particular configurations wherein the portion of the support ring to which the reflector chamber is bonded does not move appreciably in the radial direction upon inflation. Otherwise, either the reflector chamber will generally restrict proper inflation of the toroid resulting in a buckled ring structure, or the inflated ring will not properly tension the perimeter of the reflective membrane. Numerous alternate membrane configurations can be incorporated (i.e. substituted) into the basic second embodiment device as described above including membranes having any of the alternate shapes, functional characteristics, optical properties, constructions, and materials as noted for the first embodiment. The many optional valves or other inflation means available for the first embodiment are also available for the second embodiment. Note that our previous (cross-referenced) applications describe several useful alternate configurations for the toroid, membranes, valves, and other elements, all of which are generally applicable to the present invention.

[0202] FIG. 4C depicts the second main embodiment **386** in an electromagnetic radiant ray concentrating mode having the transparent membrane **388** facing the sun (not shown). The radiant solar rays **28** are illustrated as passing through the transparent membrane **388** to the reflective membrane **390**, which then reflects the rays back through the transparent membrane **388** to focus on an energy-absorbing object **394** placed at the focal point of the device **386**. Although the figure shows the focal point to be outside of the reflector chamber, it should be noted that the reflective and transparent membranes can each be pre-formed or otherwise deformed to any predetermined shape or extent (e.g., deeply pre-formed, moderately pre-formed, non-pre-formed, etc.) such that the focal point alternatively is located inside the reflective chamber such as shown in FIG. 4D, or at the surface of the transparent membrane, such as shown in FIG. 4E. However, the reader is cautioned that the latter case should be restricted to low-power (e.g., radio frequency) applications to prevent the possibility of thermally or otherwise damaging the transparent membrane and/or any integral or removable elements attached to the surface of the transparent membrane at or near the focal point. Additionally, by pre-forming the reflective membrane and transparent membrane to different extents, an asymmetrical reflector chamber is provided. For example, FIG. 4F shows a modified apparatus _____ having a deeply pre-formed reflective membrane _____ and a slightly pre-formed transparent membrane _____ to yield an asymmetrical reflector chamber _____ having a very short focal length. In contrast,

FIG. 4G shows a modified apparatus _____ having a slightly pre-formed reflective membrane _____ and a deeply pre-formed transparent membrane _____ to yield an asymmetrical reflector chamber _____ having a relatively long focal length.

[0203] **FIG. 4H** depicts the basic second embodiment reflector apparatus _____, wherein the attachment means _____ for the central reflector chamber _____ is offset or displaced from the inner periphery of the toroidal support ring _____ to accommodate a larger reflective membrane _____.

[0204] **FIG. 4I** depicts a modified basic second embodiment reflector apparatus _____, wherein the attachment means _____ for the central membranes _____ of the reflector chamber _____ are offset or displaced in opposite directions from the inner periphery of the toroidal support ring to accommodate a still larger reflective membrane _____. Note that this configuration is similar to that of the first embodiment except that the transparent membrane is highly pre-deformed to an extent that the apparatus of **FIG. 4I** cannot operate in sub-ambient mode (i.e., the central membranes would experience significant interference).

[0205] **FIGS. 5A-C** Removable Central Membranes

[0206] **FIGS. 5A-C** depict a modified first embodiment basic reflector apparatus _____ having a removable upper central membrane _____, which is removably attached via a quick attachment and sealing means _____, such as a tongue-and-groove fastening mechanism _____, to the toroid _____. **FIG. 5C** shows the removable membrane _____ having an affixed integrated multi-tongue element _____ inserted into a multi-groove element affixed to the toroid _____. The use of multiple tongues and grooves provides structural and sealing redundancy; however, a single tongue-and-groove can be used to promote economy. The lower central membrane optionally may also be removably attached by such means. Note that such means for removably attaching the central membranes allows the user to remove or replace the membranes to enable the apparatus to perform other functions, or to replace a membrane in the event of damage. To facilitate replacement, the removable central membranes and the toroid can optionally further include complementary visual and/or mechanical alignment features (not shown) such as indicia, positioning tabs, studs, alignment holes, snaps, and the like.

[0207] **FIGS. 6A-D** Removable Reflector Chamber

[0208] **FIG. 6A** depicts an alternate basic first embodiment reflector apparatus _____ having a removably attached sub-ambient/super-ambient pressurizable reflector chamber _____.

[0209] **FIG. 6B** depicts of an alternate basic second embodiment reflector apparatus having a removably attached super-ambient-pressurizable reflector chamber.

[0210] **FIG. 6C** depicts a typical hook or clip-type attachment means _____ for quickly securing a removably attachable reflector chamber of the first embodiment type _____ to the toroidal support ring _____. **FIG. 6D** depicts a similar hook or clip-type attachment means _____ for securing a removably attachable reflector chamber of the second embodiment type _____ to the toroidal support ring _____. It is noted that other common means can be

employed to attach such removable reflector chambers including, for example, one or more attachment means similar to those previously shown in **FIG. 2C** (e.g., hook-and-loop patches, a plurality of discrete mounting studs with corresponding apertures, and the like)

[0211] **FIGS. 7A-17B** Alternate Detuned Reflective Membranes

[0212] **FIG. 7A** depicts an alternate basic first embodiment reflector apparatus _____ having a detuned (i.e., non-parabolic) reflective membrane _____, (first species, first sub-species) wherein the reflective membrane _____ is pre-formed to have a spherical surface contour. Note that the rays _____ do not converge at a single point, thereby limiting the degree of concentration to enhance safety.

[0213] **FIG. 7B** depicts an alternate basic first embodiment reflector apparatus _____ having a detuned (i.e., non-parabolic) reflective membrane _____ (first species, second sub-species) wherein the reflective membrane _____ is pre-formed to have a surface contour comprising a surface-of-revolution of non-constant radius.

[0214] **FIGS. 8A and 8B** depict an alternate basic first embodiment reflector apparatus _____ having a detuned reflective membrane _____ (first species, third sub-species), wherein the reflective membrane _____ is pre-formed into the shape of a radially undulating (or radially stepped) surface of revolution. Again, **FIG. 8B** shows that the rays do not converge at a single point.

[0215] **FIGS. 9A and 9B** depict an alternate basic first embodiment reflector apparatus _____ having a detuned reflective membrane _____ (second species, first sub-species), wherein the reflective membrane _____ is pre-formed into a circumferentially undulating or scalloped shape having an even number (e.g., two) of circumferential peaks _____ and troughs _____. Similarly, **FIGS. 9C and 9D** depict an alternate basic first embodiment reflector apparatus _____ having a detuned reflective membrane _____ (second species, second sub-species), wherein the reflective membrane _____ is pre-formed into a circumferentially undulating or scalloped shape having an odd number (e.g., three) of circumferential peaks _____ and troughs _____. In **FIGS. 9B and 9D**, the electromagnetic rays shown dashed _____ represent rays in the plane of the cross-section, and the dotted lines _____ represent rays out of the plane of the cross-section. Note that the reflector of **FIG. 9B** tends to produce a vertically dispersed ray concentration pattern, whereas the reflector of **FIG. 9D** tends to produce a horizontally dispersed or annular ray concentration pattern. Note that any number of peaks and troughs may be incorporated into such circumferentially undulating or scalloped membranes.

[0216] **FIGS. 10A-B** depict an alternate basic first embodiment reflector apparatus _____ having a detuned reflective membrane _____ (third species, first sub-species), wherein the reflective membrane comprises a plurality (e.g., twelve) of pre-formed, wedge-shaped dimples _____ optionally supported by an underlying radial support grid _____ (i.e., a plurality of radial cords, wires, cables, or the like). **FIG. 10B** shows that the electromagnetic rays _____ reflected by each dimple form a diffuse, substantially linear focal locus _____ prior to diffusely converging in proximity to the primary focal axis _____ of the reflector _____.

[0217] FIGS. 11A and 11B depicts an alternate basic first embodiment reflector apparatus _____ having a detuned reflective membrane _____ (third species, second sub-species), wherein the reflective membrane _____ incorporates a plurality (e.g., eighteen) of large pre-formed substantially circular and/or elliptical dimples _____, which are generally arranged in a staggered pattern or array, such as a substantially hexagonal lattice, to maximize packing density, and further optionally including a plurality (e.g., twelve) of smaller dimples _____ (not shown) disposed around the larger dimples _____ to further minimize the non-dimpled area of the detuned reflective membrane. An optional underlying mesh _____ may be used to support and/or reinforce the dimpled reflective membrane; however, as will be shown below, a support grid or mesh is required for membranes having dimples which substantially comprise the entire surface of the membrane.

[0218] FIGS. 11C-11H depict various other dimpling patterns for dimpled detuned reflectors. Specifically, FIG. 11C depicts a dimpling pattern _____ (third species, third sub-species) incorporating a plurality (e.g., eighteen) of pre-formed substantially circular and/or elliptical dimples, which are generally arranged in a staggered concentric circular pattern or array, wherein a plurality of medium-sized dimples _____ (e.g., six) are surrounded by a plurality (e.g., twelve) of alternating smaller _____ and larger dimples _____ to maximize packing density for a given number of substantially circular and/or elliptical dimples. FIG. 11D depicts a dimpling pattern _____ (third species, fourth sub-species) incorporating a generally staggered array of large and optionally small (not shown) pre-formed substantially circular dimples _____, _____, which are arranged in such a manner so as to allow the reflective membrane to be reinforced in three directions by a plurality of linear cords, wires, cables, or the like _____ (shown dashed). FIG. 11E depicts a dimpling pattern _____ (third species, fifth sub-species) incorporating a simple, substantially rectangular array of large and optionally small (not shown) pre-formed circular dimples _____, _____, which are arranged in such a manner so as to allow the reflective membrane to be reinforced in two directions by a plurality of linear cords, wires, cables, or the like _____ (shown dashed). FIG. 11F depicts a dimpling pattern _____ (third species, sixth sub-species) incorporating a generally hexagonal array of pre-formed dimples _____ supported by a hexagonal support grid _____, wherein each dimple substantially comprises the entire-area of its associated cell _____ within the hexagonal support-grid. FIG. 11G depicts a dimpling pattern _____ (third species, seventh sub-species) incorporating a generally rectangular array of pre-formed dimples _____ supported by a rectangular support grid _____, wherein each dimple substantially comprises the entire area of its associated cell _____ within the rectangular support grid. Similarly, FIG. 11H depicts a dimpling pattern _____ (third species, eighth sub-species) incorporating a concentric annular array of tapered quadrilateral dimples _____ supported by a tapered quadrilateral support grid _____, wherein each dimple substantially comprises the entire area of its associated cell _____ within the support grid. It should be noted that dimples of any pre-determined size quantity, shape, and/or combinations thereof may be employed to tailor the light concentration pattern to a predetermined intensity and distribution, i.e. the invention is not limited to the specific examples shown.

[0219] FIGS. 12A-B depict an alternate basic first embodiment reflector apparatus _____ having a composite detuned reflective membrane _____ (fourth species, first sub-species), wherein the composite reflective membrane _____ comprises a mechanically deformable reflective membrane _____ selectively bonded to a pressure-deformable membranous substrate _____ along a plurality (e.g., twelve) of radial lines or seams _____ to provide an equal number of wedge-shaped facets _____, each of which is curved in the radial direction and substantially flat in the circumferential direction. One or more orifices _____ need to be provided to allow gas (e.g., air) to freely enter or exit the chambers or cavities _____ between the reflective and substrate membrane. Such orifices _____ can be included in and/or around the periphery the reflective membranes _____. FIG. 12B shows that the electromagnetic rays _____ reflected by each facet form a diffuse, substantially linear focal locus _____ (shown dotted) in proximity to the primary focal axis of the reflector _____.

[0220] Similarly, FIGS. 12C-D depict an alternate basic first embodiment reflector apparatus _____ having a composite detuned reflective membrane _____ (fourth species, second sub-species) wherein the composite reflective membrane _____ comprises a mechanically deformable reflective membrane _____ bonded to a pressure-deformable membranous substrate _____ along a combination of radial seams _____ and parallel-to-radial seams _____ to provide a plurality (e.g., twenty-four) of alternating wedge-shaped facets _____ and circumferentially truncated wedge-shaped facets _____, each of which is curved in the radial direction and substantially flat in the circumferential direction. FIG. 12D shows that the electromagnetic rays _____ reflected by each facet _____ form a diffuse, substantially linear focal locus _____ (shown dotted) in proximity to the primary focal axis of the reflector _____; however, this pattern produces a more uniform but more highly concentrated pattern of energy than is provided by the faceted reflector of FIG. 12B.

[0221] FIGS. 13A-B depict an alternate basic first embodiment reflector apparatus _____ having a composite detuned reflective membrane _____ (fifth species, first sub-species), wherein the composite reflective membrane _____ comprises a mechanically deformable reflective membrane _____ selectively bonded to a pressure-deformable membranous substrate _____ along a plurality (e.g., five) of equally spaced circumferential lines or seams _____ to provide a plurality (e.g., four) of conical facets _____ of equal radial width, each of which is curved in the circumferential direction and substantially flat in the radial direction. FIG. 13B shows that the electromagnetic rays _____ reflected by each facet _____ converge in proximity to the primary focal axis _____ of the reflector to provide a substantially spherical _____ pattern of concentrated light.

[0222] Similarly, FIGS. 13C-D depict an alternate basic first embodiment reflector apparatus _____ having a composite detuned reflective membrane _____ (fifth species, second sub-species), wherein the composite reflective membrane _____ comprises a mechanically deformable reflective membrane _____ bonded to a pressure-deformable membranous substrate _____ along a plurality (e.g., five) of circumferential lines or seams _____ having progressively reduced radial spacing to provide a plurality (e.g., four) of conical facets of decreasing radial width, each of

which is curved in the circumferential direction and substantially flat in the radial direction. **FIG. 13D** shows that the electromagnetic rays _____ reflected by each facet _____ converge in proximity to the primary focal axis _____ of the reflector to provide a substantially planar pattern _____ of concentrated light.

[0223] **FIGS. 14A-B** depict an alternate basic first embodiment reflector apparatus _____ having a composite detuned reflective membrane _____ (sixth species, first sub-species), wherein the composite reflective membrane _____ comprises a mechanically deformable reflective membrane _____ selectively bonded to a pressure-deformable membranous substrate _____ at a plurality of discrete points _____ in an annular pattern or array (i.e., aligned concentric circular arrays) to form a plurality (e.g., ninety-six) of substantially planar quadrilateral facets _____ having constant width in the radial direction. **FIG. 14B** shows that the electromagnetic rays _____ reflected by each facet _____ form an associated non-concentrated column of light, all of which converge in proximity to the primary focal axis _____ of the reflector to provide a substantially spherical pattern of concentrated light. It should be noted that this planar faceted configuration forms a substantially spherical pattern of concentrated energy that is more uniform than that provided by the conically faceted reflector of **FIGS. 13A-B**.

[0224] **FIGS. 14C-14F** depict various other faceting patterns for faceted detuned composite reflectors. Specifically, **FIG. 14C** depicts a faceted composite detuned reflective membrane _____ (sixth species, second sub-species), wherein the composite reflective membrane _____ comprises a mechanically deformable reflective membrane _____ bonded to a pressure-deformable membranous substrate _____ at a plurality of discrete points _____ in an annular pattern or array to form a plurality (e.g., ninety-six) of planar quadrilateral facets having decreasing width in the radial direction. Note that this planar faceted configuration forms a substantially planar pattern of concentrated energy similar to that provided by the conically faceted reflector of **FIGS. 13C-D**, but which is significantly more uniform. Similarly, **FIG. 14D** depicts a faceted composite detuned reflective membrane _____ (sixth species, third sub-species) comprising a mechanically deformable reflective membrane bonded to a pressure-deformable membranous substrate _____ at a plurality of discrete points _____ in a staggered pattern of concentric circular arrays to form a plurality (e.g., _____) of planar triangular facets _____ having optionally constant width in the radial direction. **FIG. 14E** depicts a faceted composite detuned reflective membrane _____ (sixth species, fourth sub-species) comprising a mechanically deformable reflective membrane bonded to a pressure-deformable membranous substrate at a plurality of discrete points in a generally triangular pattern or array to form a plurality (e.g., ninety-six) of planar, substantially equilateral, triangular facets. **FIG. 14F** depicts a faceted composite detuned reflective membrane _____ (sixth species, fifth sub-species) comprising a mechanically deformable reflective membrane bonded to a pressure-deformable membranous substrate _____ at a plurality of discrete points _____ in a generally annular pattern or array to form a plurality (e.g., _____) of intermixed-planar quadrilateral _____ and triangular _____ facets having decreasing width in the radial direction.

[0225] It should be noted that the use of substantially planar facets provides excellent control of the maximum degree to which the light can be concentrated. More specifically, the light concentration factor cannot exceed the number of planar facets. Further, facets of any pre-determined size quantity, shape, and/or combinations thereof may be employed to tailor the light concentration pattern to a predetermined intensity and distribution, i.e. the invention is not limited to the specific examples shown.

[0226] **FIGS. 15A and 15B** depict an alternate basic first embodiment reflector apparatus _____ having a detuned reflective membrane _____ (seventh species) comprising a mechanically deformable reflective membrane _____ bonded to an opposing membrane _____ via a plurality of internal linear radial ribs _____ and linear (i.e., chorded) circumferential ribs _____ or sheets to form, in an annular pattern, a plurality (e.g., ninety-six) of substantially planar quadrilateral facets _____ having constant width in the radial direction, whereby the reflector can be deployed without imposing a differential pressure of across the reflective membrane. However, one or more orifices _____ need to be provided to allow gas (e.g., air) to freely enter or exit the chamber(s) _____ between the reflective and opposing membranes. Such orifices _____ can be included in (and/or around the periphery of) the reflective and/or opposing membranes _____, _____, and may also be included in the internal ribs _____ to allow interconnection of the compartments _____ within the central chamber _____. Note that other faceting patterns may be produced, such as any of the preceding faceted patterns described herein, by the judicious use of radial, circumferential, and/or otherwise oriented internal ribs. Additionally, the central reflector chamber of this configuration may be pressurized to adjust the degree of energy concentration.

[0227] **FIGS. 16A and 16B** depict an alternate basic first embodiment reflector apparatus _____ having a detuned reflective membrane _____, (eighth species) wherein a secondary central inflatable pressure envelop _____ is disposed between the upper and lower pressure-deformable membranes _____, _____, (i.e., centered within the reflector chamber _____) to mildly distort the reflective membrane _____ to provide an annular focus _____. This configuration enables the concentration and distribution of light to be adjusted by varying the pressure within the secondary central pressure envelope _____.

[0228] **FIGS. 17A and 17B** depict an alternate basic first embodiment reflector apparatus _____ having a dual-focal-point, detuned reflective membrane, wherein an underlying tensioned cord, wire, or cable _____ diametrically spanning the toroid _____ distorts the reflective membrane _____ to provide two discrete detuned focal points _____, whereby the apparatus can simultaneously accommodate two distinct accessories elements (not shown), one at each focal point.

[0229] **FIGS. 18A-D** Operation as a Broad-Spectrum Electromagnetic Energy Concentrator:

[0230] **FIG. 18A** depicts the modular multi-function apparatus _____ being used to concentrate solar energy _____ to heat or cook materials _____ contained in a vessel _____ supported by the cable-stayed focal point support _____ in proximity to the focal point _____.

[0231] **FIG. 18B** depicts the modular multi-function apparatus _____ being used to concentrate solar energy _____

to distill liquids _____ contained in a distillation apparatus _____ supported by the cable-stayed focal point support _____ in proximity to the focal point _____.

[0232] FIG. 18C depicts the modular multi-function apparatus _____ being used to provide thermal energy by concentrating sunlight _____ onto a heat exchanger _____ supported by the cable-stayed focal point support _____ in proximity to the focal point _____, wherein a liquid effluent _____ is cyclically heated and piped via conduits _____ to and from an insulated energy-storage vessel _____ or thermal reservoir.

[0233] FIG. 18D depicts the modular multi-function apparatus _____ being used to generate electrical power by concentrating sunlight _____ onto a liquid-cooled photoelectric cell _____ supported by the cable-stayed focal point support _____ in proximity to the focal point _____. Electrical conduits _____ transmit electrical energy to a device requiring electrical power. Note that thermoelectric cells can also be employed for the purpose. Further note that the optional heat exchanger _____ used to cool the photovoltaic cell device can effectively be used to provide heat as in FIG. 18C.

[0234] FIGS. 19A-D Operation as a High-Gain Radio-Frequency Antenna:

[0235] FIG. 19A depicts the modular multi-function apparatus _____ being used as a high-gain antenna _____ to enable electronic communications between a geo-synchronous satellite _____ and a ground-based communications device _____, such as a portable computer, by supporting via the cable-stayed focal point support _____ a basic antenna _____ at the focal point of a sub-ambient pressurized reflector chamber _____. Electrical conduits _____ are shown connecting the basic antenna _____ to the ground-based communications device _____.

[0236] FIG. 19A depicts the modular multi-function apparatus _____ being used as a high-gain antenna _____ to enhance electronic communications between a distant radio transmission tower _____ and a portable transceiver device _____, wherein the transparent membrane _____ of a super-ambient pressurized reflector chamber _____ is alternatively used to support a basic antenna _____ in proximity to the focal point _____. Note that the basic antenna device may be integrally incorporated into the transparent membrane as an integral conductive wire, mesh, or other suitable conductive element (not shown). Also note that for this and other applications, the transparent membrane need only be transparent to the particular spectrum of electromagnetic radiation (e.g., RF) being manipulated by the apparatus. Accordingly, the invention contemplates that the transparent membrane _____ can be opaque, translucent, or otherwise disruptive to higher energy spectra, (e.g., broad-spectrum solar energy, visible light, infrared, and the like) to prevent inadvertent damage to the transparent membrane and/or an accessory element (such as a portable transceiver device, cellular phone, and the like) supported thereon in the event the apparatus inadvertently becomes aligned with a high-energy electromagnetic source, such as the sun.

[0237] FIG. 19C depicts the modular multi-function apparatus _____ being used as a high-gain antenna _____ to extend the range of electronic communications between two portable transceiver devices _____ by attaching one of the

transceiver devices directly to the spherical support element _____. This configuration allows the apparatus to be quickly converted between various operational modes, such as between use as a high-gain antenna and use as, for example, a broad-spectrum concentrator.

[0238] FIG. 19D depicts two electrically interconnected modular multi-function apparatuses _____ located on a mountain _____ and being used as high-gain antenna apparatuses (each similar to those shown above in FIGS. 19A-C) to a relay electronic communications between a low-lying transmission tower _____ and a third modular apparatus _____ located on opposite sides of the mountain. It is noted that a single modular multi-function apparatus may be reconfigured by the user to provide two or more reflector modules (such as by attaching a removable reflector chamber to, for example, the separate toroidal support ring _____ or the rings of the safety shield _____), thus enabling a single apparatus to serve as a relay station between non-aligned remote stations. However, depending on the element selected to support the auxiliary removable reflector chamber, alternate means for supporting the apparatus may need to be implemented.

[0239] FIGS. 20A-C Operation as a Visible Spectrum Concentrator and Projector:

[0240] FIG. 20A depicts the modular multi-function apparatus _____ being used to project a collimated beam of light _____ for enhancing vision, signaling, and the like, by locating a non-collimated light source _____ at the focal point _____ of a sub-ambient pressurized reflector chamber _____. Various light-sources can be used for this application including, for example, a gas or oil lantern, an electrical lamp, a candle, a torch, a phosphorescent glow stick, and the like. Note that the device can optionally include reflectors, transparent covers, and/or transparent membranes (if used in super-ambient mode) having various colors to enable the device to project a wider range of signals, or to project colored illumination, such as for artistic purposes.

[0241] FIG. 20B depicts the modular multi-function apparatus _____ being used to concentrate moonlight _____ from a crescent moon _____ onto an item _____ to be viewed at night, such as a map _____ or compass, optionally held in proximity to the focal point _____ by the transparent membrane _____ of a super-ambient pressurized reflector chamber _____. Note that other dim or distance sources of light may also be used for this application, such as a distant street lamp, or the glow emanating from a distant city skyline. Also note that the apparatus alternatively can be deployed in sub-ambient mode for this other applications disclosed herein.

[0242] FIG. 20C depicts the modular multi-function apparatus _____ being used in conjunction with an accessory waveguide device _____ to concentrate and transmit concentrated solar or lunar radiation _____ via waveguide _____ to an underwater lamp _____ to provide panchromatic illumination _____ for use by a diver (not shown). Note that this configuration can also be used to provide illumination for interior, subterranean, and/or other darkened environments, or to energize optical equipment such as, for example, an image projection device, a heated tool, or a surgical device.

[0243] FIGS. 21A-D Operation as a Support or Shelter:

[0244] FIG. 21A depicts the modular multi-function apparatus _____ being used in an upright position as an insulated crib, cradle, or incubator, such as to hold an infant _____. In addition to the reflective membrane _____, the invention contemplates that many of the other elements of the apparatus, such as the interior and/or exterior walls of the safety shield _____ can have a reflective surface _____ to enhance the thermal insulating characteristics of the apparatus. FIG. 21B depicts the modular multi-function apparatus _____ being used in a horizontal position by a person _____ as a seat or chair _____, and as a shield from the sun, wind, and/or inclement weather. FIG. 21C depicts the modular multi-function apparatus _____ being used in an inverted position as a shelter to protect a person from inclement weather or other environmental elements. By further incorporating an optional camouflaged external surface _____ the apparatus effectively serves as a wildlife blind or hunting blind. FIG. 21D depicts the modular multi-function apparatus _____ in a partially disassembled and reconfigured condition, wherein the toroidal base ring _____ is being used as an open flotation device to support a person _____ on water _____, and the remainder of the apparatus is being used as an enclosed flotation device _____ or weather-resistant gear closet. The apparatus can also be used a portable cage, terrarium, aquarium, greenhouse, frost shield, and the like. These applications can be facilitated by the inclusion of an integral or removably attached cover, such as a transparent cover (not shown) to enable use as a greenhouse, or a fine mesh cover (not shown) to enable use as cage for small animals or insects. Note that such a fine mesh cover can also be used at an insect shield (e.g., mosquito net) when using the device as a shelter, incubator, and the like.

[0245] FIGS. 22A-C Operation as a Water Collection, Storage, and Processing Apparatus:

[0246] FIG. 22A depicts the modular multi-function apparatus _____ being used to provide potable water _____ by capturing, purifying, and/or storing precipitation _____ (or other sources of water), wherein additional collection area is optionally provided by an outwardly extended safety cover _____.

[0247] FIG. 22B depicts the modular multi-function apparatus _____ being used in conjunction with a transparent cover _____ and a liquid collection vessel _____ to produce potable water by first condensing onto the transparent membrane _____ the water vapor _____ emitted from moist materials _____ placed within the apparatus and passively heated by solar radiation, and then collecting the resulting condensate _____ in the collection vessel _____. The collection vessel _____ is shown supported by the cable-stayed focal point support _____; however, it can be alternatively supported, such as by attaching it to the transparent cover _____, which is particularly useful when the moist materials are optionally heated by concentrated energy at the focal point. Note that the apparatus shown in FIG. 22B can be also used as a dehydrator, dryer, or curing chamber by providing a means for exhausting vapor from the chamber, such as a partially open cover, or an open valve or loading port.

[0248] FIG. 22C depicts a disassembled and reconfigured modular multi-function apparatus _____ being used to

provide potable water by collecting precipitation and/or dew, wherein the collection area of the apparatus is greatly increased as a result of separating its basic modular components. Note that accessory membranes _____, such as removable covers, removable reflective membranes, and/or removable reflector chambers, are shown attached to the various toroid rings _____ of the disassembled modular apparatus to provide a water collection surface.

[0249] FIGS. 23A-N Operation as a Wind Turbine:

[0250] FIG. 23A depicts a reconfigured modular multi-function apparatus _____ being used to harness wind energy, wherein a lightweight accessory wind turbine generator device _____ is mounted via the cable-stayed focal point support _____ within the inflatable safety cage _____, which is supported horizontally, facing the wind, by the remaining modules of the apparatus. Conduits _____ are provided for transmitting electrical and/or mechanical power to other accessory apparatus (not shown).

[0251] FIG. 23B depicts a reconfigured multi-function apparatus _____ being used to harness wind energy, wherein the lower inflatable toroidal support ring _____ is utilized to structurally stabilize a very lightweight collapsible (membranous) accessory wind turbine _____, which is mounted aft of the inflatable safety cage on a horizontal accessory rod to facilitate wind-pointing.

[0252] FIG. 23C depicts a reconfigured multi-function apparatus _____ being used to harness wind energy, wherein an accessory wind turbine device is supported within the inflatable toroidal support ring _____, which has its wind-facing side movably attached to a vertical line support _____ to enable wind-pointing, and which further utilizes a plurality of inflatable rings _____ from the safety shield _____ attached to its aft side both to augment airflow through the turbine and to further enhance wind-pointing.

[0253] FIG. 23D depicts a reconfigured multi-function apparatus _____ being used to harness wind energy in a manner similar to that depicted in FIG. 9C, but further including additional inflatable rings, optionally from the safety cage, located between the line support and the wind-facing side of the toroidal support ring to promote venturi-flow augmentation through the wind turbine, and to further enhance wind-pointing.

[0254] FIG. 23E depicts wind-facing view of a collapsible lightweight wind turbine _____ formed by attaching a plurality of flexible membranous blades _____ to one of the inflatable toroidal support rings _____ in such a manner so as to provide twist in each blade _____ (i.e., the blade angle decreases with increasing radius) both to enhance aerodynamic performance and to facilitate connection to a central axial hub.

[0255] FIG. 23F depicts the lightweight wind turbine _____ depicted in FIG. 23E being used to produce electrical power, wherein the wind turbine is attached to a generator _____ mounted on a horizontal shaft _____, which is movably connected to a vertical cable support _____ to enable wind-pointing, and to permit the apparatus to be elevated into higher velocity wind streams.

[0256] FIG. 23G depicts a wind-facing view of a collapsible lightweight wind turbine _____ formed by attaching the tips _____ of a plurality of simple, generally non-

twisted, flexible membranous blades _____ to one of the inflatable toroidal support rings _____, wherein the plurality of blades is economically fabricated primarily from a single flexible membrane.

[0257] FIG. 23H depicts the lightweight wind turbine _____ depicted in FIG. 23G, wherein the wind turbine _____ is attached to a generator _____ mounted on a horizontal shaft _____, which is movably connected to a stand _____ formed in part by a vertically oriented accessory rod _____ attached to the basic inflatable reflector apparatus _____ and stabilized by a plurality of cables _____.

[0258] FIG. 23I depicts wind-facing view of a lightweight wind turbine _____ formed by attaching a slotted, pre-formed membrane _____ having a central mounting hub _____ to the front side of the inflatable toroidal support ring _____, and by further attaching a structural safety net _____ having a central hub _____ to the aft side of the inflatable toroidal support ring _____, wherein the two central hubs _____ are used to stably mount the wind turbine to the shaft of a generator (not shown).

[0259] FIG. 23J depicts the slotted-membrane wind turbine _____ depicted in FIG. 23I, wherein the turbine blades _____ are formed by locally slitting and pre-deforming a substantially conical membrane _____.

[0260] FIG. 23K depicts a slotted-membrane wind turbine _____ similar to that depicted in FIG. 23I, wherein the turbine blades _____ are formed by locally slitting and deforming a substantially planar membrane _____.

[0261] FIG. 23L depicts a slotted-membrane wind turbine _____ similar to that depicted in FIG. 23I, wherein the turbine blades _____ are formed by locally slitting and deforming a shallow, concave, substantially spherical membrane _____.

[0262] FIG. 23M depicts a slotted-membrane wind turbine _____ similar to that depicted in FIG. 23I, wherein the turbine blades _____ are formed by locally slitting and deforming a deeply concave, substantially spherical membrane _____ that is alternatively attached to the aft end of the toroidal support ring _____ so as to not interfere with the stabilizing structural safety nets _____ mounted to the front and aft sides of the toroidal support ring _____.

[0263] FIGS. 24A-D Operation for Miscellaneous Applications:

[0264] FIG. 24A depicts the modular multi-function apparatus _____ being used as a high-gain directional sound-amplification device _____, wherein an accessory microphone _____ is attached at the focal point _____ and connected to an amplifying headset _____ to listen, for example, to the auditory chirp of a bird _____. Note that the naked ear (not shown) can also be placed in proximity to the focal point to hear distant and/or faint sounds.

[0265] FIG. 24B depicts the modular multi-function apparatus _____ being used as a fermentation apparatus _____ by attaching an anaerobic airlock/pressure-relief valve _____ to the upper central membrane _____. Note that the portable fermentor apparatus optionally can be deployed (i.e., floated) on water to provide temperature stabilization.

[0266] FIG. 24C depicts the modular multi-function apparatus _____ being used to sieve or filter liquid and/or solid

materials by attaching suitable accessory meshes _____ and/or other filter media to the apparatus.

[0267] FIG. 24D depicts the modular multi-function apparatus _____ being used as a floating aquatic chamber _____ to hold live fish _____.

[0268] FIGS. 25A-D Alternate Methods for Constructing the Spherical Support and Safety Shield:

[0269] FIG. 25A depicts an alternate modular inflatable multi-function _____ apparatus having a low-inflation-volume alternate spherical support _____ and an simplified alternate inflatable safety cage _____, wherein the low-inflation-volume sphere cal support _____ is formed by connecting a plurality of inflatable toroidal rings _____ of decreasing major diameter, and the simplified inflatable safety cage _____ is formed by connecting a plurality of inflatable toroidal rings _____ of substantially equal minor and major diameter.

[0270] FIG. 25B depicts an alternate modular inflatable multi-function apparatus _____ having an alternate inflatable spherical support _____ and an alternate inflatable safety cage _____, each of which comprises an inner membrane _____ and an outer membrane _____ joined by a plurality of spaced, continuous circumferential, membranous ribs _____ (i.e., cylindrical, conical, or annular membranes) to form a plurality of optionally interconnected compartments _____ within each structure.

[0271] FIG. 25C depicts an alternate modular inflatable multi-function apparatus _____ having an alternate inflatable spherical support _____ and an alternate inflatable safety cage _____, each of which typically comprises an inner membrane _____ and outer membrane _____, which are joined to each other at their peripheral edges to form an inflatable pressure envelop _____, and which are further joined by a plurality of internal, finite, circumferentially spaced, membranous ribs _____ (i.e., substantially planar radial membranes at discrete circumferential positions) to hold the inner and outer membranes _____, _____ in a predetermined shape, and to form (typically) a plurality of optionally interconnected compartments _____ within each structure.

[0272] FIG. 25D depicts an alternate modular inflatable multi-function apparatus _____, wherein the spherical support _____ alternatively comprises a plurality (e.g., two) of stacked, progressively smaller basic reflector apparatuses _____, and wherein the safety shield _____ alternatively comprises a plurality or alternate basic reflector apparatuses _____ having removable reflective membranes and/or removable reflector chambers (not shown) which are removed and stowed to allow light to strike the primary reflector _____.

[0273] FIG. 26 depicts an alternate modular inflatable multi-function apparatus _____ comprising a reflective membrane _____ integrated with low-inflation-volume combination spherical support and focal point support _____, wherein the inner portion of the reflective membrane _____ is supported above the spherical support _____ in a pressure-deployable arrangement, and the outer portion of the reflective membrane _____ is intermittently attached to the spherical support _____ in a mechanically deployable arrangement.

[0274] FIGS. 27A-D Alternate Safety Cages:

[0275] FIG. 27A depicts an alternate modular multi-function apparatus _____ having an integral alternate inflatable safety cage _____, wherein a plurality (e.g., four) of substantially linear inflatable tubes _____ are integrally connected to the toroidal support ring _____ of the basic reflector apparatus _____ and to an upper inflatable toroidal ring _____ to form a lightweight tubular structure _____, and wherein several of the openings _____ within the lightweight tubular structure, are covered with a flexible mesh or net _____, both to provide a physical barrier around the focal point, and to enhance the structural stability of the integral safety cage. Note that by making the safety cage integral with the toroid _____, both structures can be inflated simultaneously by providing one or more interconnecting gas ports _____ between the structures. This configuration significantly enhances safety by preventing the use of the apparatus _____ without a substantially fully deployed safety cage _____.

[0276] FIG. 27B depicts an alternate modular multi-function apparatus _____ having a removably attached alternate inflatable safety cage _____, wherein a plurality of linear (but optionally curved) inflatable tubes _____ are integrally connected to both an upper and a lower inflatable toroidal ring _____ to form a removable lightweight tubular structure _____, and wherein several of the openings _____ within the lightweight tubular structure _____ are covered with a flexible mesh or net _____, both to provide a physical barrier around the focal point, and to enhance the structural stability of the removable safety cage _____.

[0277] FIG. 27C depicts an alternate modular multi-function apparatus _____ having a removably attached alternate inflatable safety cage _____, wherein a plurality of connected linear inflatable tubes _____ form a lightweight truss structure _____, and wherein several of the openings _____ within the lightweight truss structure _____ are covered with a flexible mesh or net _____, both to provide a physical barrier around the focal point, and to enhance the structural stability of the removable safety cage _____.

[0278] FIG. 27D depicts an alternate modular multi-function apparatus _____ having a removably attached alternate inflatable safety cage _____ comprising a plurality of linear inflatable tubes _____ integrally connected to both an upper and a lower inflatable toroidal ring _____ to form a removable lightweight tubular structure _____, wherein several of the openings _____ within the side of the tubular structure _____ are covered with a light-attenuating flexible transparent membrane _____, and the upper opening _____ of the tubular structure is covered with a membranous grid or grating _____ to provide off-axis light attenuation.

[0279] FIGS. 28A-D Tapered Support and Leveling Rings:

[0280] FIG. 28A depicts a basic inflatable reflector apparatus _____ being supported by a plurality of inflatable tapered support and leveling rings _____, wherein the thinnest portions of the stacked tapered rings _____ are located at one circumferential position, whereby the apparatus can be progressively inclined to a nearly vertical orientation by progressively inflating the tapered rings. Alternatively, the device can be oriented in a nearly hori-

zontal position by substantially deflating the rings _____ as shown in FIG. 28B. Note that the tapered rings can be inflated simultaneously using one valve _____ by providing interconnecting gas ports _____ between the rings as shown, or inflated separately via individual gas valves _____ for each tapered ring.

[0281] FIG. 28C depicts a basic inflatable reflector apparatus _____ being supported by plurality of inflatable tapered support and leveling rings _____, wherein the inclination of the basic reflector apparatus is substantially minimized by alternately positioning the thinnest portions of adjacent stacked rings at opposite circumferential location as shown, but wherein the inclination of the basic reflector apparatus optionally can be maximized by positioning the thinnest portions of the stacked rings at one circumferential location. Note that the rings can also be used to level the apparatus when placed on an inclined surface _____, such as a hill or roof, as shown in FIG. 28D.

[0282] FIGS. 29A-D Alternate Combination/Dual-Use Safety Cages and Device Supports:

[0283] FIG. 29A depicts an alternate modular multi-function apparatus _____ having an alternate integral inflatable safety cage _____ and a substantially identical alternate integral inflatable spherical support _____, both of which comprise two orthogonally connected semicircular tubes optionally integrally attached to the basic reflector apparatus. Also shown is an alternate inflatable focal point support _____ comprising two localized or discrete inflatable pressure vessels _____ removably attached to the basic reflector apparatus _____ for supporting via brackets _____ a rod _____ diametrically spanning the basic reflector apparatus _____.

[0284] FIG. 29B depicts an alternate modular multi-function apparatus _____ having an alternate removably attached inflatable safety cage _____ and a substantially identical alternate removably attached inflatable spherical support _____, both of which comprise two orthogonally connected inflatable semicircular tubes _____ integrally attached to an inflatable toroidal ring _____. Also shown is an alternate means _____ for supporting a rod _____ diametrically spanning the basic reflector apparatus _____, wherein the rod _____ is removably attached via a bracket _____ or other fastening means to the inflatable toroidal ring _____ of the safety cage _____.

[0285] FIG. 29C depicts an alternate modular multi-function apparatus _____ having an alternate inflatable means for supporting the apparatus _____ and a substantially identical alternate inflatable focal point support _____, both of which comprise a removably attached adjustable truss _____ comprising a plurality (e.g., three) of linear inflatable tubes _____, wherein each inflatable tube _____ has a plurality of individually inflatable compartments _____ with separate inflation valves _____ as a means for adjusting its length.

[0286] FIG. 29D depicts an alternate modular multi-function apparatus _____ having an alternate inflatable means _____ for supporting the apparatus _____ and a similar alternate inflatable focal point support _____, each of which comprises a removably attached inflatable tube stabilized by a plurality of tensioned lines or cable stays. Note that two or more inflatable tubes may be use to enhance stability or provide structural redundancy.

[0287] FIGS. 30A-B Alternate Non-Inflated Collapsible Combination Safety Cages and Device Supports.

[0288] FIG. 30A depicts an alternate modular multi-function apparatus _____ having an alternate collapsible rigid safety cage _____ and a substantially identical alternate collapsible rigid spherical support _____, each of which comprise a plurality (e.g., five) of semicircular rigid elements _____ rotatably attached (i.e., pinned) to one side of the inflatable toroidal support ring _____ of the basic reflector apparatus _____ at diametrically opposed pin joints _____, and which further comprise a plurality of cords or cable stays _____ connected to the semicircular rigid elements _____ and to the basic reflector apparatus _____ to stabilize the collapsible structure _____.

[0289] FIG. 30B depicts an alternate modular multi-function apparatus having an alternate globe-shaped combination collapsible rigid safety cage and spherical support comprising _____ a plurality (e.g., twelve) of semicircular rigid elements, which are rotatably attached (i.e., pinned) to each other via pin joints _____ located above and below the basic reflector apparatus _____ along the focal axis _____ of the device, and which are further attached to the inflatable toroidal support ring _____ of the basic reflector apparatus _____ both to support the reflector apparatus _____ and to stabilize the collapsible structure _____.

[0290] FIGS. 31A-D Alternate "Globe-Type" Collapsible Rigid Element Combination Safety Cage and Device Supports:

[0291] FIGS. 31A and 31B depict an alternate configuration of the modular multi-function apparatus _____ comprising a sub-ambient pressurized removable reflector chamber _____ (third species) removably attached via hooks _____, clips, or the like, to the equatorial rim _____ and the bottom pole _____ of an optionally collapsible, globe-shaped, truss-like, support structure _____ couched within an inflatable toroidal support ring _____.

[0292] FIG. 31C depicts an alternate configuration of the modular multi-function apparatus _____ comprising a sub-ambient pressurized removable reflector chamber _____ (first species) having its upper side removably attached via hooks _____, clips, or the like, to the equatorial rim _____ and its lower side similarly removably attached to a lower parallel rim _____ of an optionally collapsible, globe-shaped, truss-like, support structure _____ couched within an inflatable toroidal support ring _____.

[0293] FIG. 31D depicts an alternate configuration of the modular multi-function apparatus _____ comprising a super-ambient-pressurized, removable reflector chamber _____ (second species) removably attached via hooks _____, clips, or the like, to the equatorial rim _____ of a the globe-shaped, truss-like, support structure _____ couched alternatively in a ground depression _____, such as may be dug in sand.

[0294] FIGS. 32A-H Alternate Cable-Stayed Focal Point Supports:

[0295] FIG. 32A depicts an alternate collapsible, cable-stayed focal point support _____ (second species) comprising a square, rigid frame _____ removably attached to the upper and lower surfaces of an inflatable safety cage _____ using four pairs of cords, wires, or cable stays _____,

whereby various accessory elements can be supported in proximity to the focal point.

[0296] FIG. 32B depicts of an alternate collapsible focal point support _____ (third species) comprising a circular gimble _____ (i.e., a self-leveling pivoting frame) movably attached via pin joints _____ to a hexagonal rigid frame _____, which is removably attached to the upper and lower surfaces of an inflatable safety cage _____ using six pairs of cords, wires, or cable stays _____, wherein an accessory element supported by the gimble _____ in proximity to the focal point can be self-leveling as shown, or optionally adjusted and held in a predetermined orientation using an optional adjustment and securing means (not shown), such as a friction clamp at one of the pivot joints _____.

[0297] FIG. 32C depicts an alternate collapsible focal point support _____ (fourth species) comprising a circular gimble _____ (i.e., a self-leveling pivoting frame) movably attached via two pin joints _____ to six pairs of cords, wires, or cable stays _____, which are removably attached to the upper and lower surfaces of an inflatable safety cage _____, wherein an accessory element supported by the gimble in proximity to the focal point can be self-leveling.

[0298] FIG. 32D depicts an alternate collapsible focal point support _____ (fifth species) comprising a rigid square frame _____ removably attached to the upper and lower surfaces of an inflatable safety cage _____ using four pairs of cords, wires, or cable stays _____, and further comprising an internally reflective, articulated structure _____ attached to the upper side of the rigid frame _____, whereby accessory elements can be supported in a horizontal (i.e., level) or other predetermined orientation, and the radiant energy entering the lower end of the reflective articulated structure _____ can be redirected to the bottom of an accessory element (not shown), such as a pan, to improve performance.

[0299] FIG. 32E depicts an alternate collapsible focal point support _____ (sixth species) comprising a small bracket or ring _____ attached via four pairs of cords, wires, or cable stays _____ to the upper and lower surfaces of an inflatable safety cage _____, whereby various accessory elements (not shown) can be supported in proximity to the focal point.

[0300] FIG. 32F depicts an alternate collapsible focal point support _____ (seventh species) comprising a short rod, tube, or length of cable _____ attached via four pairs of cords, wires, or cable stays _____ to the upper and lower surfaces of an inflatable safety cage _____, whereby various accessory elements (not shown), such as a kettle, can be suspended or otherwise supported in proximity to the focal point.

[0301] FIG. 32G depicts an alternate collapsible focal point support _____ (eighth species) comprising two substantially fixed small brackets or rings _____, each of which is attached via three (or other number) pairs of cords, wires, or cable stays _____ to the upper and lower surfaces of an inflatable safety cage _____, and further comprising an adjustable wire loop _____ attached between the two brackets or rings _____, whereby various accessory elements, such as a cooking or heating vessel, can be supported in a self-leveling manner in proximity to the focal point. Note that the wire loop can optionally have a cinching means (not shown) for securing the cables around an undersized accessory element.

[0302] FIG. 32H depicts an alternate collapsible focal point support _____ (ninth species) comprising a flexible wire or cable basket _____ removably attached via six pairs of cords, wires, or cable stays _____ to the upper and lower surfaces of an inflatable safety cage _____, whereby various accessory elements and/or materials (not shown) to be heated, such as a cooking vessel, pre-packaged food items, and/or certain solid foodstuffs, can be securely supported in proximity to the focal point in either a random or predetermined orientation.

[0303] FIGS. 33A-B Waveguide and Secondary Reflectors:

[0304] FIG. 33A depicts a basic first embodiment reflector apparatus _____ operating in super-ambient pressure mode to focus light rays _____ into an accessory waveguide device _____ connected to the upper transparent membrane _____ in proximity to the focal point of the apparatus _____.

[0305] FIG. 33B depicts an alternate basic first embodiment reflector apparatus _____ having a pressure-deployable convex secondary reflective membrane _____ centered within the transparent membrane _____ of a super-ambient pressurized reflector chamber _____, wherein light rays _____ entering the apparatus _____ are progressively concentrated by the primary and secondary reflectors _____, _____ into an accessory waveguide device _____ connected to the center of the primary reflector _____ in proximity to the focal point of the modified (compound) reflector apparatus _____. Note that the waveguide depicted herein can optionally be a light-weight fluid-filled tube, instead of the conventional coated glass or polymer fiber(s).

[0306] FIGS. 34A-D Operation as a Fluid Pump:

[0307] FIG. 34A depicts a basic first embodiment reflector apparatus _____ modified with one-way fluid valves _____ (i.e., check valves) to facilitate inflation, to prevent accidental deflation, and to facilitate use of the apparatus as a manual fluid pump _____.

[0308] FIG. 34B depicts is a modified basic first embodiment reflector apparatus _____ configured as a manual fluid pump _____ illustrating the fluid intake stroke, wherein the central membranes _____ are manually separated (i.e., extended outward) to draw fluid _____ (typically air) into the central reflector chamber _____ through the upper valve _____.

[0309] FIG. 34C depicts a modified basic first embodiment reflector apparatus _____ configured as a manual fluid pump _____ illustrating the fluid exhaust stroke, wherein the central membranes _____ are manually forced together (i.e., forced inward) to expel or exhaust fluid _____ (typically air) from the central reflector chamber _____ through the upper valve _____.

[0310] FIG. 34D depicts a modified basic first embodiment reflector apparatus _____ configured as a manual fluid pump _____ illustrating the fluid exhaust stroke, wherein the central membranes _____ are manually forced together (i.e., forced inward) to expel or exhaust fluid _____ (typically air) from the central reflector chamber _____ through the lower valve _____ into an attached

accessory tube _____, which may be connected to any suitable accessory device (not shown) requiring inflation.

[0311] FIGS. 35A-35E Accessory Membranes for Enhanced Water Collection and/or Shelter:

[0312] FIG. 35A depicts a basic first embodiment reflector apparatus _____ further including a plurality (e.g., six) of attached membranes or covers _____, which are shown extended in a petal-like arrangement to enhance liquid collection by augmenting the capture area of the apparatus _____, but which can also have various optical properties (such as color, transparency, opacity, emissivity, reflectivity, selective reflectivity, and the like) and, thus, can be used to enhance or enable numerous optical functions of the apparatus.

[0313] FIG. 35B depicts a basic first embodiment reflector apparatus _____ further including a large extended rectangular (or other shaped) multi-layer insulated membrane or sheet _____ attached to the upper surface of the multi-function reflector apparatus _____ to greatly enhance liquid collection in the form of precipitation, dew, or frost. Ties _____ are shown for supporting or elevating the periphery of the membrane _____; however, one or more inflatable tubes may be used to support the membrane in a cupped configuration, as will be shown below. Note that the upper surface of the membrane _____ (and/or many other surfaces of the modules of the present invention) can have a high emissivity surface to enhance the collection of dew or frost at night by radiative condensation processes. Further, note that the multi-layer insulated membrane can also serve as an emergency thermal blanket, insulating ground cloth, protective tarp or cover, and the like. Additional membranes _____ and/or membranes of any other practical shape may also be used.

[0314] FIG. 35C depicts a basic first embodiment reflector apparatus _____ further including a large extended, optionally multi-layer insulated, membrane or sheet _____ supported at its edge by a plurality of inflatable tubes _____, such as those described above in FIG. 29C, to provide a modified apparatus _____ having cupped configuration _____ to facilitate water collection. Similarly configured apparatus _____ can also be used as a self-supporting shelter _____, such as shown in FIG. 35D, or suspended to form an umbrella _____, such as shown in FIG. 35E.

[0315] FIGS. 36-37 Miscellaneous Apparatus

[0316] FIG. 36 depicts a modified first embodiment reflector apparatus _____ further including optional accessory elements for facilitating the collection and storage of water, including a peripheral gutter _____ having a drain port _____ for connection to a conduit _____, which is shown further connected to the lower valve _____ to permit water collected in the gutter _____ to be transferred to the reflector chamber _____ for storage. An optionally valved conduit _____ extending through the toroid _____ can also be used to transfer water effluent _____ to the reflector chamber _____ for storage.

[0317] FIG. 37 depicts a modified first embodiment reflector apparatus _____ configured as a portable sealed work chamber _____ having a pair of attached gloves _____ and a covered access port _____ incorporated into an optionally removably attached upper transparent membrane _____.

[0318] FIGS. 38A-B Self-Supporting Automated Sun-Tracking Devices:

[0319] FIG. 38A depicts a modular multi-function apparatus (with the inflatable safety cage and the cable-stayed focal point support omitted from the figure for clarity) having an optional automated means for tracking the vertical motion or elevation of the sun (i.e., a single-axis sun-tracking apparatus), wherein the modular multi-function apparatus further includes a motor-driven cable connected between the upper portion of the apparatus and its supporting toroidal base ring, at least one motorized drive pulley typically attached to the toroidal base ring, and a sun-sensing controller electrically connected via electrical conduits both to the motorized drive pulley and to an electrical power supply, such as a rechargeable battery and/or photovoltaic panel. Note that the toroidal base ring is configured to hold water such that, when filled, it provides a substantially frictionless support for the inflatable spherical support module, which floats on the water-filled base ring. Note that opposite sides of the toroidal support ring of the basic reflector apparatus are connected to toroidal base ring via flexible cords or cables to stabilize the upper portion of the apparatus relative to the lower toroidal support ring, which can be secured to the ground, for example, by cables and stakes as shown, or by other means.

[0320] FIG. 38B depicts a modular multi-function apparatus (with the inflatable safety cage and the cable-stayed focal point support omitted from the figure for clarity) having an optional automated means for tracking both the vertical and horizontal motion of the sun (i.e., a dual-axis sun-tracking apparatus), wherein the modular multi-function apparatus of FIG. 38A having a single-axis tracking apparatus further includes an additional larger water-filled base ring on which the first base ring floats, an additional motor-driven cable connected between the primary base ring and the larger secondary base ring, and one non-driven and one driven pulley, the latter of which is electrically connected via electrical conduit to the sun-sensing controller and electrical power supply.

[0321] FIGS. 39A-C Suspended Automated Sun-Tracking Apparatus:

[0322] FIG. 39A depicts a modular multi-function apparatus (with the inflatable safety cage and the cable-stayed focal point support omitted from the figure for clarity) having an alternate automated means for tracking both the vertical and horizontal motion of the sun (i.e., a dual-axis sun-tracking apparatus), wherein the modular multi-function apparatus of FIG. 38A having a single-axis tracking mechanism is rotatably suspended via a cable system between an overhead support, such as a tree branch, and a staked ground support to enable substantially frictionless motion about the vertical axis, and further includes an additional motor-driven cable connected between the toroidal base ring and one non-driven and one motor-driven pulley, both of which are supported by ground stakes, and the latter of which

is electrically connected via electrical conduit to a sun-sensing controller and an electrical power supply.

[0323] FIG. 39B depicts a basic first embodiment reflector apparatus having a dual-axis (i.e., vertical and horizontal) sun-tracking mechanism, wherein the basic reflector apparatus is suspended via a cable system between an overhead support, such as a tree branch, and a staked ground support to enable substantially frictionless motion about the vertical and horizontal axes, and further comprises two motor-driven cables (one for each axis of rotation), and two motorized drive pulleys (one for each axis of rotation), both of which are supported by ground stakes and are electrically connected via electrical conduit to a sun-sensing controller and an electrical power supply.

[0324] FIG. 39C depicts a basic first embodiment reflector apparatus having a polar-aligned, single-axis, sun-tracking mechanism (i.e., the axis of the tracking mechanism is optionally aligned with poles or rotational axis of the earth), wherein the basic reflector apparatus is suspended via a cable system between an overhead support, such as a tree branch, and a staked ground support to enable substantially frictionless motion about an axis parallel to the Earth's axis of rotation, and further comprises one motor-driven cable and one motorized drive pulley, the latter of which is supported by a ground stake and is electrically connected via electrical conduit to a sun-sensing controller and an electrical power supply.

[0325] FIGS. 40A-40D Materials of Construction

[0326] FIG. 40A depicts a typical, substantially polymeric, multi-layer composite material from which the apparatus can be constructed, comprising from bottom to top: a heat-sealable layer of material (such as polyethylene, and the like), a load-bearing structural membrane (such as Nylon, Mylar®, and the like), a smooth reflective layer (such as provided by vapor-deposited aluminum, and the like), and a protective upper coating (such as lacquer, polyethylene, and the like), which optionally may also be heat-sealable.

[0327] FIG. 40B depicts an alternate, substantially polymeric, multi-layer composite material from which the apparatus can be constructed, comprising from bottom to top: a heat-sealable polymer material, a longitudinally oriented load-bearing structural polymer membrane, an intermediate polymeric bonding or interface material, a transverse-oriented load-bearing structural polymer membrane, a reflective metallic layer, and a protective polymer coating which also serves as a heat-sealable layer, whereby the two cross-stacked, directionally-oriented membranes increase strength and tear resistance of the composite membrane.

[0328] FIG. 40C depicts a fiber-reinforced multi-layer composite material from which the apparatus can be constructed, comprising from bottom to top: a heat-sealable polymer material, a bi-axially oriented load-bearing structural polymer membrane, an intermediate polymeric bonding or interface material

_____, a layer of reinforcing fibers shown, for example, in a bi-axial weave _____, a second intermediate polymeric bonding or interface material _____, a second bi-axially oriented load-bearing structural polymer membrane _____, a reflective metallic layer _____, and a protective polymer coating _____ which also serves as a heat-sealable layer, whereby the fiber reinforcement greatly improves the strength and tear resistance of the multi-layer composite membrane.

[0329] FIG. 40D depicts a fiber-reinforced composite material _____ from which the non-reflective portions of the apparatus can be constructed, comprising a layer of reinforcing fibers _____ in, for example, a bi-axial weave integrally imbedded in a heat-sealable polymer matrix material _____, whereby an economical, high-strength, tear-resistant composite membrane is provided for the non-reflective portions of the apparatus. Note that this material can also optionally incorporate a reflective surface.

[0330] Finally, to facilitate many of the applications of the modular inflatable field-deployable apparatus of the present invention as described herein, it should be noted that various common electronic and/or mechanical accessory devices or apparatus can be integrally or removably incorporated into any apparatus of the instant invention in any useful quantity, location, and combination thereof. Such optional electrical and/or mechanical accessory devices include, but are not limited to, pumps, fans, drive motors, timers, thermostats, flow controllers, photovoltaic cells, movable louvers or iris apparatus (for controlling flow or radiation), and other useful elements. To further enhance the collection, storage, processing, and distribution of water or other liquids, it should be noted that various common liquid handling and processing devices can also be integrally or removably incorporated into any apparatus of the instant invention in any useful quantity, location, and combination including, but not limited to, liquid pumps, pipes, tubes, funnels, valves, pressure gauges, flow meters, flow controllers, filters, and other useful elements.

[0331] Thus, the extensive applicability of the fundamental modular inflatable multifunction field-deployable apparatus has been disclosed.

We claim:

1. A modular multifunction field-deployable apparatus comprising:

a ring support element, said ring support element comprising at least one substantially tubular and inflatable ring, said ring support element defining a vacant center;

at least one inflation means for inflating said ring support element;

at least two pressure-deformable membranes extending across the center of said ring support element, said membranes and said ring support element defining at least one inflatable reflector chamber, at least one of said membranes having a means for reflecting electromagnetic radiation; and

at least one pressure adjusting or inflating means for adjusting the pressure within said reflector chamber.

2. The apparatus according to claim 1, wherein said ring support element and said membranes are made from sub-

stantially thin, strong, and flexible sheets of at least one type or class of substantially polymeric materials,

whereby said apparatus is suitably lightweight, compactly foldable, and sufficiently durable for ease of transport to and substantially safe and dependable use in a range of terrestrial and non-terrestrial environments.

3. The apparatus according to claim 1, wherein said inflation means and said pressure adjusting means are at least one valve comprising a flexible conduit closed by a closure means selected from the group consisting of:

an affixed flexible plug;

a flexible tongue-and-groove or Ziploc-type valve;

a self-sealing membrane valve;

a clamp; and

a tie.

4. The apparatus according to claim 1, further comprising at least one accessory device attached to said apparatus, the accessory device being selected from the group consisting of:

a handle;

an apertured tab-for hanging when in storage;

a tying or hanging strap;

a storage pouch for storing the deflated and folded apparatus; and

a pouch for filling with dense material to stabilize the apparatus.

5. The apparatus according to claim 1, further comprising at least one fastener device attached to said apparatus, the fastener device being selected from the group consisting of:

a clevis;

a clip;

a bracket;

a mounting stud;

a socket;

a line; and

a hook-and-loop fastening patch.

6. The apparatus according to claim 1, wherein the plurality of pressure-deformable membranes are at least two reflective membranes including a primary reflective membrane and at least one redundant or auxiliary reflective membrane, wherein each of said reflective membranes has predetermined functional characteristics, whereby said reflective membranes may have identical or dissimilar functional characteristics.

7. The apparatus according to claim 1, further comprising at least one access port having a fluid-tight cover, whereby materials and equipment may be added to and removed from the apparatus.

8. The apparatus according to claim 1, wherein at least one of said pressure-deformable membranes has at least one outlet duct or port, whereby substantially fluidic materials can be transferred to, from, or through at least one said reflector chamber.

9. The apparatus according to claim 8, wherein said port has a conduit extending through said reflector chamber,

whereby substantially fluidic materials collecting on the top of the apparatus are drained through said conduit to an external location substantially below said reflector chamber.

10. The apparatus according to claim 1, wherein said ring support element comprises at least two of said substantially inflatable and tubular rings, at least one of said rings being attached to and above at least one other of said rings substantially above said pressure-deformable membranes,

whereby the external volume capacity of the apparatus is increased and an inflatable focal point support element is provided.

11. The apparatus according to claim 1, wherein said ring support element comprises at least two of said substantially inflatable and tubular rings, at least two of said rings being located between at, least two of said pressure-deformable membranes,

whereby the internal volume capacity of the apparatus is increased.

12. The apparatus according to claim 1, further including at least one gutter attached to said ring support element for capturing falling materials, whereby the effective capture area is increased.

13. The apparatus according to claim 1, further comprising at least one stretched elastic band attached to at least one surface of at least one of said pressure-deformable membranes to cause wrinkling as a safety means.

14. The apparatus according to claim 1, further including at least one cover attached to at least one point of said apparatus as a safety means, said cover being rollable into a retracted position.

15. A modular field-deployable apparatus substantially optimized for use as a radiant electromagnetic energy concentrating, focusing and beaming apparatus comprising:

a, ring support element, said ring support element comprising at least one substantially tubular and inflatable ring, said ring support element defining a vacant center;

at least one inflation means for inflating said ring support element;

at least two pressure-deformable membranes extending across the center of said ring support element, said membranes and said ring support element defining at least one inflatable reflector chamber, at least one of said membranes having a means for reflecting electromagnetic radiation;

at least one pressure adjusting or inflation means for adjusting the pressure within said reflector chamber; and

at least one means for performing at least one function not involving concentrating, focusing, and beaming radiant electromagnetic energy, said means selected from the group consisting of:

- a means for collecting fluid;
- a means for storing fluid;
- a means for distributing fluid;
- a means for processing fluid;
- a means for fermenting materials;
- a means for storing material;

- a means for providing waterborne flotation;
- a means for providing snowborne transportation;
- a means for providing a compliant support;
- a means for immobilizing a broken limb;
- a means for concentrating sound;
- a means for providing electrostatic insulation;
- a means for providing thermal insulation; and
- a means for providing electromagnetic insulation,

whereby the apparatus also provides at least one non-electromagnetic or non-focused electromagnetic function.

16. A method of establishing at least one function or element of life-sustaining infrastructure utilizing a modular field-deployable apparatus comprising the steps of:

providing a ring support element, said ring support element comprising at least one substantially tubular and inflatable ring, said ring support element defining a vacant center;

providing at least one inflation means for inflating said ring support element;

providing at least two pressure-deformable membranes extending across the center of said ring support element, said membranes and said ring support element defining at least one inflatable reflector chamber, at least one of said pressure-deformable membranes being reflective to electromagnetic radiation;

providing at least one pressure adjusting or inflation means for adjusting the pressure within said reflector chamber; and

deploying said ring support element and said pressure-deformable membranes in a manner effective for performing a selected function.

17. The method according to claim 16, wherein the deploying step comprises the following steps:

inflating said ring support element to support and tension the periphery of said pressure-deformable membranes;

adjusting pressure within said reflector chamber to deform at least one reflective membrane into a functional concave reflector; and

positioning the reflective membrane in a manner effective for allowing transmission of radiant electromagnetic energy between a source and target,

whereby an energy absorbing object placed in proximity to the focal point can absorb concentrated radiant electromagnetic energy for at least one application selected from cooking, heating, and processing of materials, electrical power generation, receiving electromagnetic communications or signals, and providing illumination, and

whereby an energy emitting object placed in proximity to the focal point can project radiant electromagnetic energy for at least one application selected from transmitting electromagnetic communications or signals, and providing illumination.

18. The method according to claim 16, wherein the deploying step comprises the following steps:

inflating said ring support element to support and tension the periphery of said pressure deformable membranes;

adjusting pressure within said reflector chamber to deform at least one membrane into a substantially concave surface; and

positioning said apparatus in a substantially horizontal orientation with the substantially concave surface facing upward,

whereby said apparatus can capture and/or hold substantially fluidic materials including, for example, precipitation, leaking fluids, draining fluids, and/or moderately sized solid materials, and

whereby said apparatus can support persons or objects on land and on water.

19. The method according to claim 16, wherein the deploying step comprises the following step:

positioning said apparatus between an element and the surrounding environment to shield or insulate said element from said environment,

whereby said apparatus can provide thermal, electrostatic, and electromagnetic insulation.

20. A modular multifunction field-portable apparatus comprising:

a ring support element, said ring support element comprising at least one substantially tubular and inflatable ring, said ring support element defining a vacant center;

at least one inflation means for inflating said ring support element;

at least two pressure-deformable membranes extending across the center of said ring support element, said membranes and said ring support element defining at least one inflatable central chamber; and

at least one pressure adjusting or inflation means for adjusting the pressure within said reflector chamber,

whereby the apparatus provides at least one non-electromagnetic function.

* * * * *