

(12) **United States Patent**  
**Hooper et al.**

(10) **Patent No.:** **US 11,097,434 B2**  
(45) **Date of Patent:** **Aug. 24, 2021**

(54) **UTILITY KNIFE**

(71) Applicants: **Mark Gordon Hooper**, Wilson, NC (US); **Rodney Miller**, Wilson, NC (US); **David Christopherson**, Raleigh, NC (US)

(72) Inventors: **Mark Gordon Hooper**, Wilson, NC (US); **Rodney Miller**, Wilson, NC (US); **David Christopherson**, Raleigh, NC (US)

(\*) Notice: Subject to any disclaimer, the term of this patent is extended or adjusted under 35 U.S.C. 154(b) by 66 days.

(21) Appl. No.: **16/229,449**

(22) Filed: **Dec. 21, 2018**

(65) **Prior Publication Data**

US 2019/0193288 A1 Jun. 27, 2019

**Related U.S. Application Data**

(60) Provisional application No. 62/608,871, filed on Dec. 21, 2017.

(51) **Int. Cl.**

**B26B 1/00** (2006.01)  
**B26B 5/00** (2006.01)  
**B26B 1/10** (2006.01)  
**B26B 29/02** (2006.01)  
**B26B 1/04** (2006.01)  
**B26B 3/08** (2006.01)

(52) **U.S. Cl.**

CPC ..... **B26B 1/10** (2013.01); **B26B 5/003** (2013.01); **B26B 5/005** (2013.01); **B26B 29/02** (2013.01); **B26B 1/042** (2013.01); **B26B 3/08** (2013.01)

(58) **Field of Classification Search**

CPC ..... B26B 1/042; B26B 1/10; B26B 29/02; B26B 3/08; B26B 5/003; B26B 5/005;

B26B 1/00; B26B 1/02; B26B 1/06; B26B 1/08; B26B 5/001; B26B 5/006  
USPC ... 30/158, 159, 160, 161, 307, 319, 164, 95, 30/365, 114, 2, 151, 162, 286, 289, 292, 30/293, 154-156  
See application file for complete search history.

(56) **References Cited**

U.S. PATENT DOCUMENTS

1,820,014 A	8/1931	Fenton et al.	
1,858,170 A	5/1932	Edward et al.	
2,260,223 A *	10/1941	Harper	B26F 1/36
			83/468.93
2,602,221 A *	7/1952	Ewing	B26B 21/50
			30/36
2,722,782 A *	11/1955	Metz	B24B 3/58
			451/231
3,034,565 A *	5/1962	Hillix	B23K 9/035
			72/385

(Continued)

FOREIGN PATENT DOCUMENTS

CN 101248951 A \* 8/2008

*Primary Examiner* — Jason Daniel Prone

(74) *Attorney, Agent, or Firm* — Dunlap Bennett & Ludwig, PLLC; Brendan E. Squire

(57) **ABSTRACT**

An ergonomically designed, auto-retracting utility knife that can safely remain in the user's hand while performing non cutting tasks. This invention allows a person to continue with the jobs they were performing by having the ability to use both hands and not having to set the utility knife down between manual tasks, thus saving time and increasing efficiency. An auto-retracting blade decreases the risk lacerations and other hand/wrist injuries to the user and others during routine use of the knife.

**10 Claims, 4 Drawing Sheets**

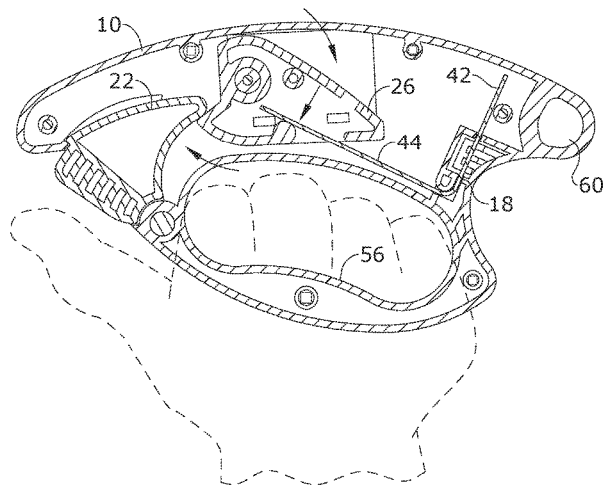
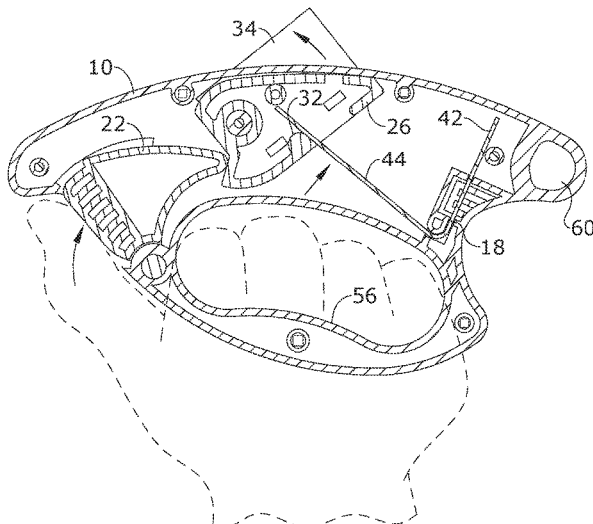

(56) **References Cited**

U.S. PATENT DOCUMENTS

3,374,814	A *	3/1968	Kaufmann	.....	B23D 49/165	8,065,803	B2 *	11/2011	Austin	.....	B26B 5/003
											30/151
						8,122,605	B2 *	2/2012	Votolato	.....	B26B 5/003
											30/2
3,506,102	A *	4/1970	Mathison et al.	.....	G07F 17/24	8,220,160	B2 *	7/2012	Davis	.....	B26B 29/02
											30/162
						8,307,556	B2 *	11/2012	Davis	.....	B26B 5/003
											30/162
3,641,667	A *	2/1972	Leopoldi	.....	B26B 5/005	8,353,109	B2 *	1/2013	Rohrbach	.....	B26B 5/003
											30/162
						8,707,565	B2 *	4/2014	Muccino	.....	B26B 5/001
3,981,526	A	9/1976	Lundqvist								30/125
4,683,656	A *	8/1987	Peyrot	.....	B26B 5/003	8,707,566	B2 *	4/2014	Rohrbach	.....	B26B 5/001
											30/162
4,703,561	A	11/1987	Parisek			8,769,826	B2 *	7/2014	Wu	.....	B26B 5/003
4,713,885	A *	12/1987	Keklak	.....	B26B 5/003						30/125
						8,776,380	B1 *	7/2014	Quimby	.....	B26B 5/003
											30/155
4,757,612	A *	7/1988	Peyrot	.....	B26B 29/02	8,782,909	B1	7/2014	Davis et al.		
						8,931,180	B2 *	1/2015	Davis	.....	B26B 5/003
											30/162
4,769,912	A *	9/1988	Davis	.....	B26B 1/08	9,358,692	B2 *	6/2016	Schekalla	.....	B26B 5/003
											30/162
4,989,320	A	2/1991	Borkott et al.			9,579,808	B2 *	2/2017	Scimone	.....	B26B 5/003
5,103,564	A	4/1992	MacDonald			9,650,065	B2 *	5/2017	Davis	.....	B26B 5/003
5,299,355	A *	4/1994	Boda	.....	B26B 5/003	9,925,674	B2 *	3/2018	Scimone	.....	B26B 5/003
						9,956,695	B2 *	5/2018	Chung	.....	B26B 5/000
5,303,474	A *	4/1994	Keklak	.....	B26B 5/003	10,112,312	B2 *	10/2018	Schekalla	.....	B26B 5/003
						10,124,495	B2 *	11/2018	Gallegos	.....	B26B 5/001
						10,137,588	B1 *	11/2018	Davis	.....	B26B 29/02
5,426,855	A *	6/1995	Keklak	.....	B26B 5/003	10,245,736	B2 *	4/2019	Huang	.....	B26B 5/003
						10,279,491	B2 *	5/2019	Scimone	.....	B26B 1/10
5,476,474	A *	12/1995	Davis	.....	A61B 5/150022	10,300,615	B2 *	5/2019	Votolato	.....	B26B 3/06
						10,583,572	B2 *	3/2020	Herlitz	.....	B26B 5/001
						10,913,168	B1 *	2/2021	Salvitti	.....	B26B 1/10
5,495,670	A *	3/1996	Quinn	.....	B26B 5/001	2004/0216309	A1	11/2004	Mueller		
						2004/0237312	A1 *	12/2004	Hernandez	.....	B26B 5/003
											30/162
5,568,243	A *	10/1996	Durfee	.....	G03G 15/168	2005/0044726	A1 *	3/2005	Summers	.....	B26B 5/001
											30/294
5,711,077	A *	1/1998	Schulz	.....	B26B 25/005	2005/0193568	A1 *	9/2005	Peyrot	.....	B26B 5/001
											30/162
5,890,294	A *	4/1999	Keklak	.....	B26B 5/001	2009/0106983	A1 *	4/2009	Berns	.....	B26B 5/003
											30/162
6,122,828	A *	9/2000	Asterino, Jr.	.....	B26B 29/02	2010/0199504	A1	8/2010	Caldwell et al.		
						2010/0251552	A1	10/2010	Gazcon et al.		
6,148,520	A *	11/2000	Berns	.....	B26B 5/003	2011/0119925	A1 *	5/2011	Rohrbach	.....	B26B 5/003
											30/158
6,553,673	B2 *	4/2003	Peyrot	.....	B26B 5/003	2011/0119927	A1 *	5/2011	Mueller	.....	B26B 5/001
											30/162
6,643,936	B2 *	11/2003	Carlson	.....	B26B 25/005	2012/0192434	A1 *	8/2012	Syrjala	.....	B26B 1/08
											30/162
D484,769	S	1/2004	Cheung			2013/0061477	A1 *	3/2013	Lutgen	.....	B26B 5/003
6,785,966	B2 *	9/2004	Berns	.....	B26B 5/003						30/158
						2014/0208594	A1 *	7/2014	Scimone	.....	B67B 7/30
6,813,833	B2 *	11/2004	Saunders	.....	B26B 5/003						30/2
						2014/0366385	A1 *	12/2014	Herlitz	.....	B26B 5/001
6,857,192	B1 *	2/2005	Summers	.....	B26B 5/001						30/162
7,051,443	B2 *	5/2006	Mueller	.....	B26B 29/02	2015/0202784	A1	7/2015	Ranfelt		
						2020/0023528	A1 *	1/2020	Rohrbach	.....	B26B 5/001
7,322,110	B2 *	1/2008	Hernandez	.....	B26B 5/001	2020/0338767	A1 *	10/2020	Rohrbach	.....	B26B 5/003
											30/162
D602,757	S *	10/2009	Kishida	.....	D8/99						
7,765,701	B2 *	8/2010	Okada	.....	B26B 5/003						
8,056,241	B2 *	11/2011	Davis	.....	B26B 5/003						

\* cited by examiner

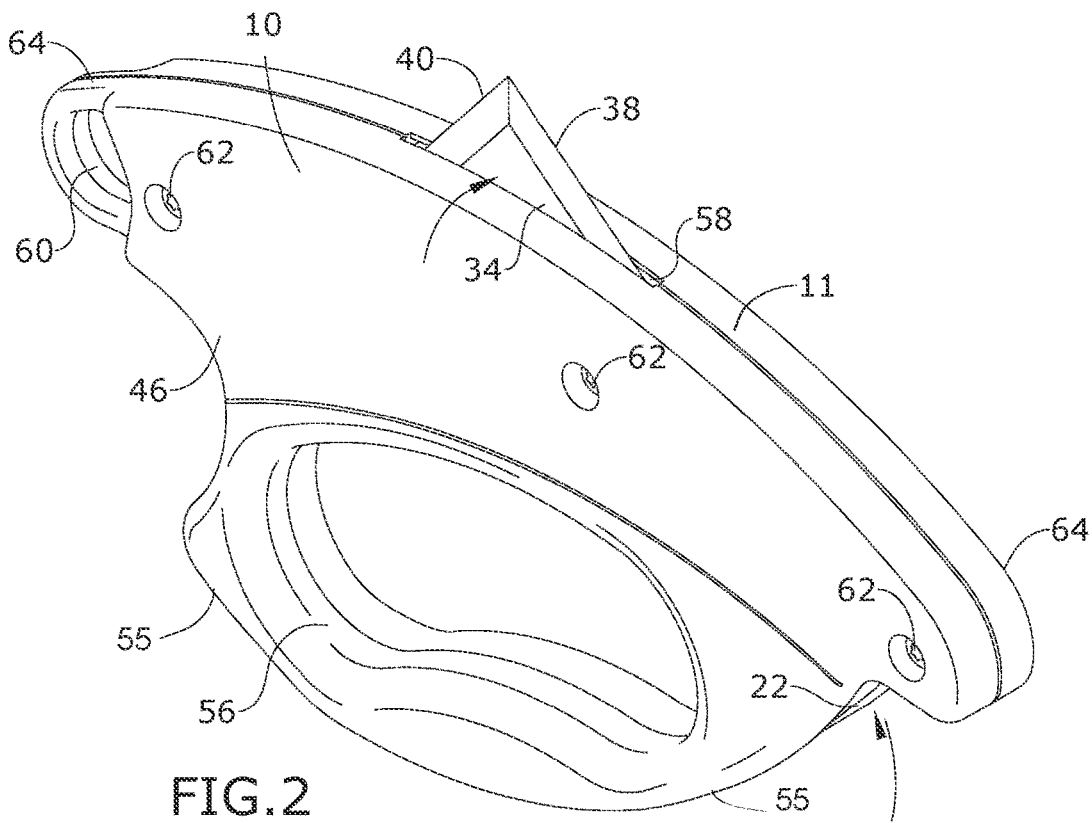
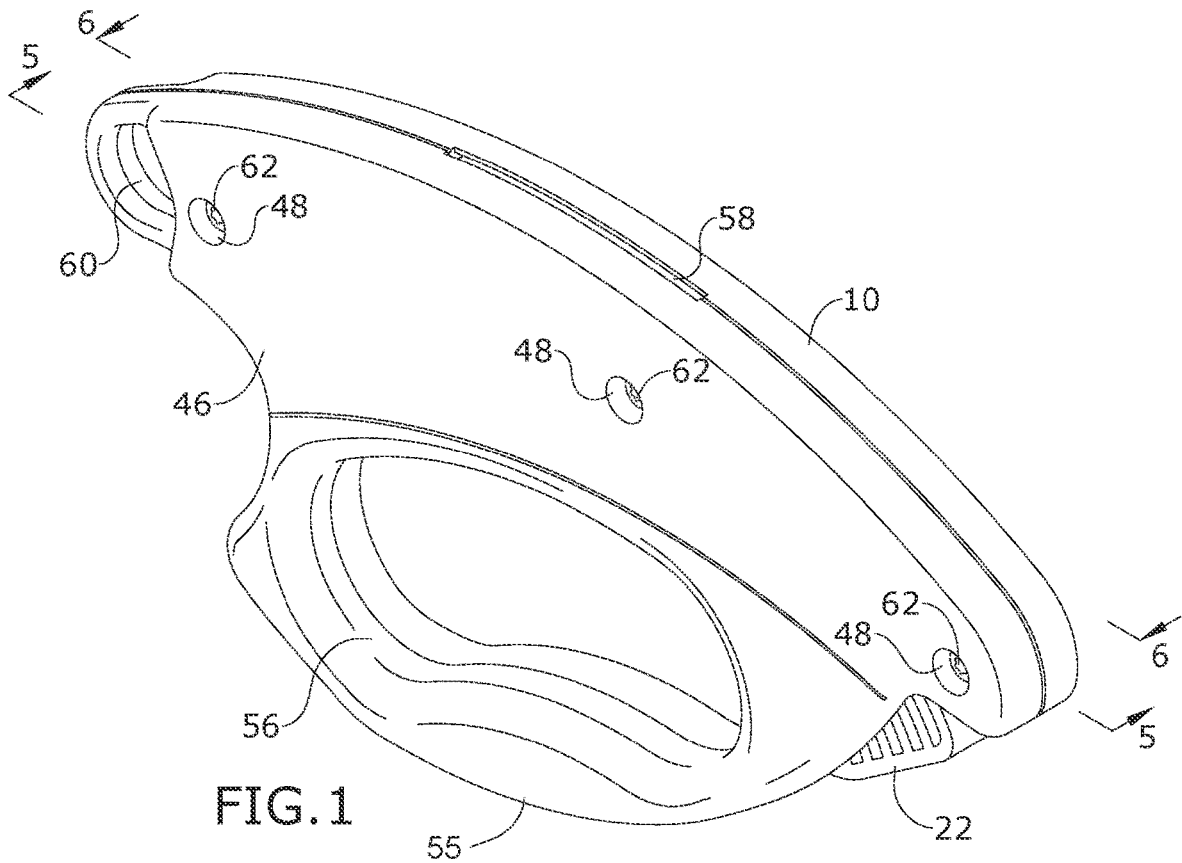



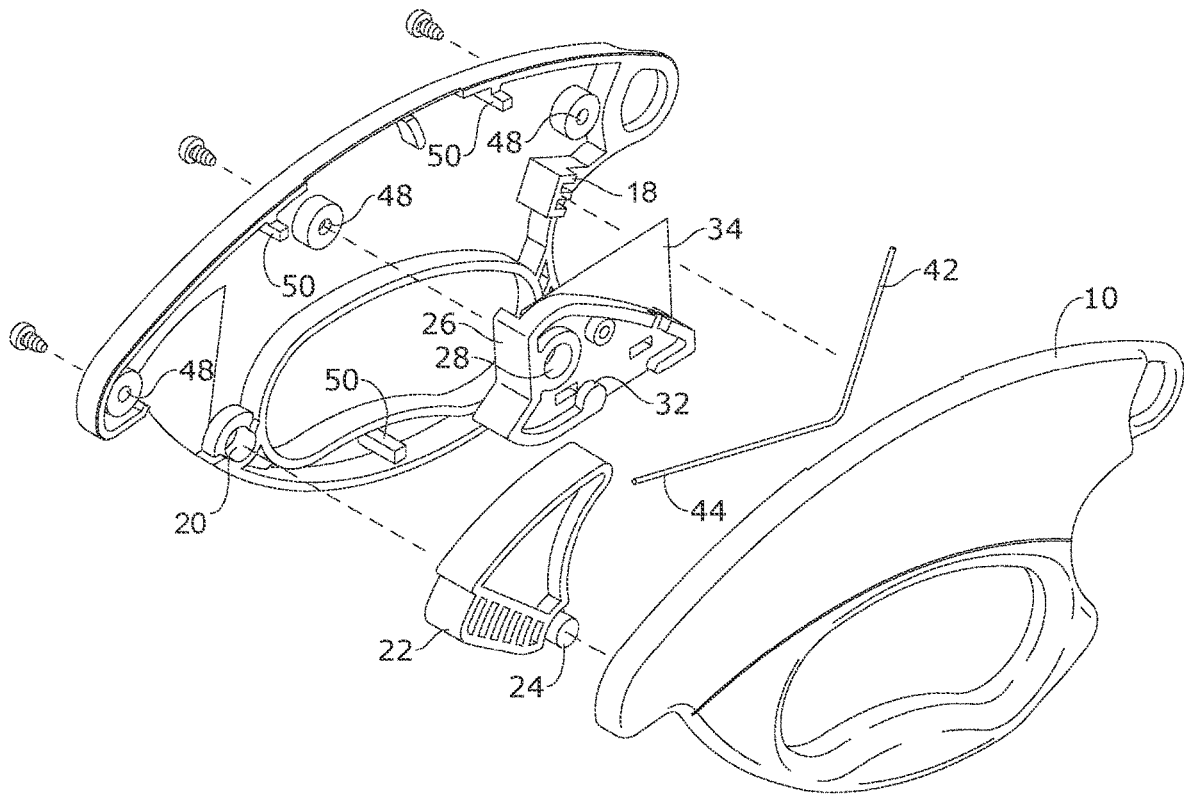

FIG. 4

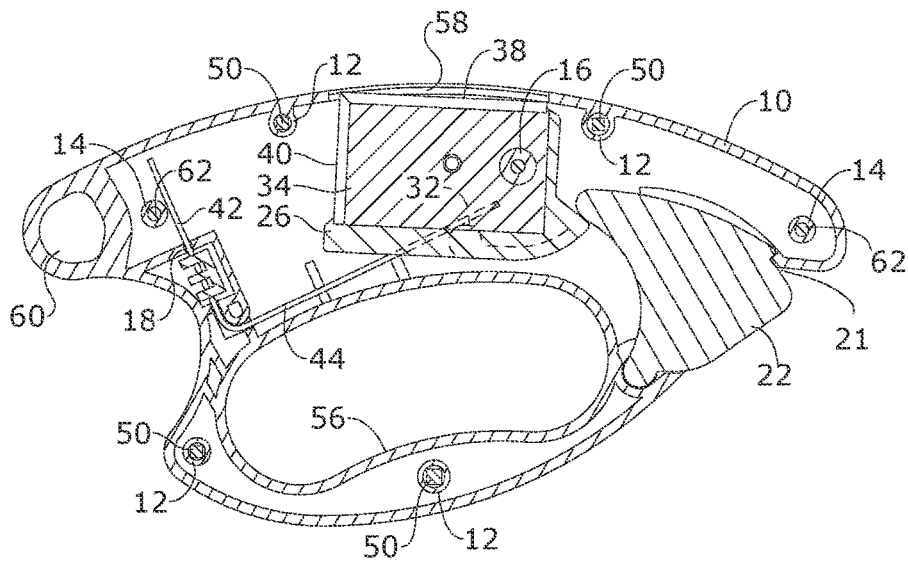

FIG. 5

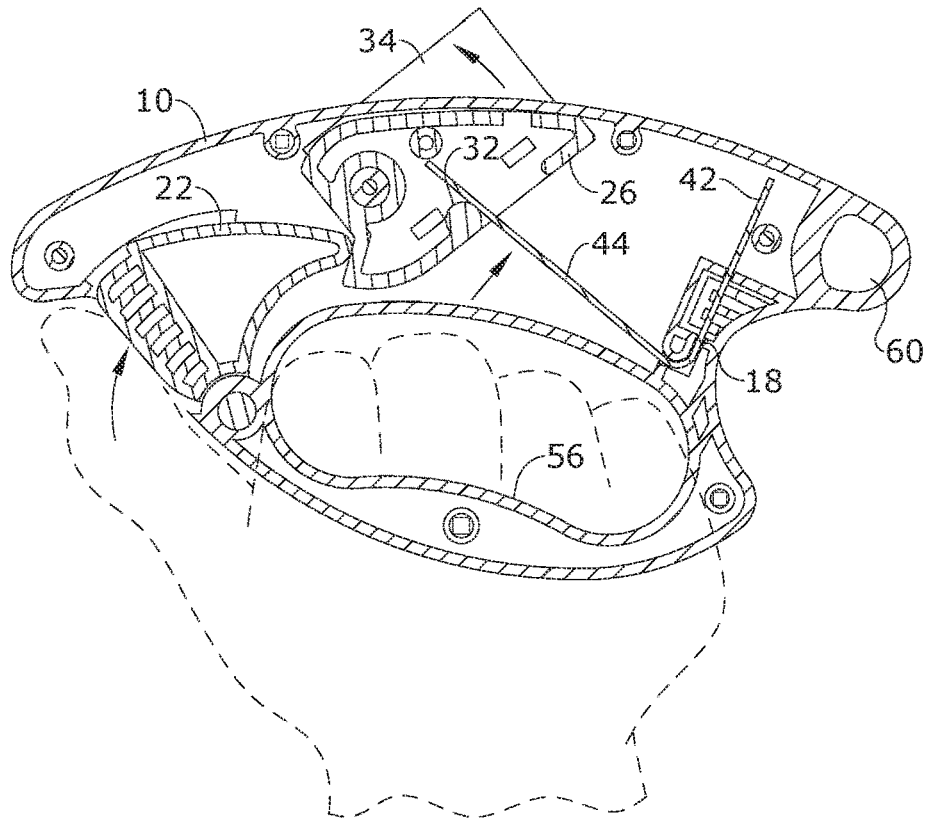

FIG. 6

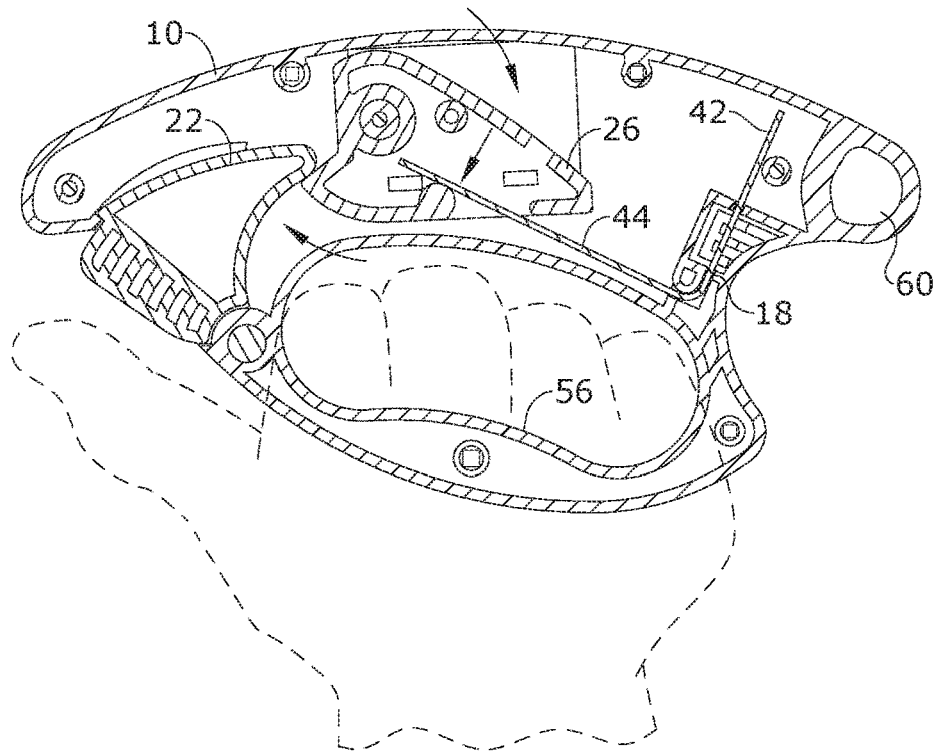

FIG. 7

1

## UTILITY KNIFE

CROSS-REFERENCE TO RELATED  
APPLICATION

This application claims the benefit of priority of U.S. provisional application No. 62/608,871, filed Dec. 21, 2017, the contents of which are herein incorporated by reference.

## BACKGROUND OF THE INVENTION

The present invention relates to utility knives, and more particularly utility knives with a retractable cutting blade.

Common utility knives require the user to put down the knife in order to perform subsequent tasks especially when you need the use of both hands. The common utility knife, or box cutter, can become lost because it is often set down frequently to perform other tasks after utilizing the box cutter, such as stocking shelves with a product carried in the box. Also, because the knife must be put down each time the user needs the use of both hands, valuable time is wasted in performing tasks. The box cutter also may slip or accidentally be dropped with its exposed blade, thereby posing a potential hazard of injury to the user or others.

Common utility knives have many flaws. In particular, most do not have auto-retracting blade, which means that when the user has completed the cutting task, the dangerous razor blade remains exposed. Additionally, the common utility knife must be set down repetitively or stored in the users pocket or work-belt so the user must ensure, every time, that the blade is fully retracted or it may cause injury to others or themselves. The repetitive action of having to set down the knife adds additional wasted time to complete the overall tasks performed.

As can be seen, there is a need for an improved utility knife that addresses these deficiencies.

## SUMMARY OF THE INVENTION

In one aspect of the present invention an ergonomic utility knife is disclosed. The knife includes an elongate housing having a slotted opening defined along a cutting face of the elongate housing. A handle has an opening defined through a lateral face of the elongate housing. The opening is configured to receive one or more digits of a user's hand. A blade holder is retractably carried within the housing. A trigger is configured to be operated by a thumb of the user when the utility knife is held in a user's hand. The trigger is operable to urge the blade holder towards the slotted opening to a cutting position.

Preferably, a biasing means is provided to move the blade holder away from the slotted opening when the trigger is released in order to return the blade holder to a stowed position. The biasing means may be a spring.

In some embodiments, the cutting face of the elongate housing is arcuate. An outer surface of the handle, opposite the cutting face, has a curvature that is dimensioned to rest in a palm of the user's hand when held by the one or more digits of the user's hand.

In other embodiments, at least one lobe extends from an end of the cutting face. An indentation may be formed in the housing subjacent to the lobe, between the cutting face and the handle.

In yet other embodiments, the trigger is pivotally disposed within the housing. A first end of the trigger protrudes from a trigger opening in the housing. A second end of the trigger

2

urges against the blade carrier when the trigger is depressed. The blade holder may also be pivotally disposed within the housing.

In yet other embodiments, the utility knife includes a blade carried by the blade holder.

These and other features, aspects and advantages of the present invention will become better understood with reference to the following drawings, description and claims.

## BRIEF DESCRIPTION OF THE DRAWINGS

FIG. 1 is a perspective view of the utility knife.

FIG. 2 is a perspective view of the utility knife, showing the extension of blade 34 when trigger 22 is pushed.

FIG. 3 is an front perspective exploded view of the utility knife.

FIG. 4 is an rear perspective exploded view of the utility knife.

FIG. 5 is a section view of the utility knife, taken along line 5-5 in FIG. 1.

FIG. 6 is a section view of the utility knife, taken along line 6-6 in FIG. 1 illustrating the movement of blade 34, holder 26, and spring leg 44 when trigger 22 is depressed.

FIG. 7 is a section view of the utility knife, illustrating the automatic retracting of blade 34 when the trigger 22 is released.

DETAILED DESCRIPTION OF THE  
INVENTION

The following detailed description is of the best currently contemplated modes of carrying out exemplary embodiments of the invention. The description is not to be taken in a limiting sense, but is made merely for the purpose of illustrating the general principles of the invention, since the scope of the invention is best defined by the appended claims.

Broadly, embodiments of the present invention provide a utility knife with an ergonomic design and auto-retracting blade that allow the utility knife to be carried in the user's hand (right or left) while the user continues to perform other work tasks. The user can also safely perform other tasks such as; grasp items, type, write, use a cell phone or tablet device, tie, twist, drink/eat, while the knife remains on the users hand, ready for use. The auto-retractable blade remains safely retracted and unexposed until the user depresses the trigger button to activate the blade.

As seen in reference to the drawings of FIGS. 1-7, a utility knife, according to aspects of the present invention includes an elongate housing 10 having a slotted opening 58 defined along a cutting face 11 of the elongate housing 10. A handle opening 56 is defined through a lateral face 46 of the elongate housing 10. The handle opening 56 is configured to receive one or more digits of a user's hand. A blade holder 26 is retractably carried within the housing 10. The blade holder 26 is configured to retain a replaceable utility knife blade 34, which may be carried by one or more blade grips 30. The knife blade 34 may be configured with a first cutting edge 38 and a second cutting edge 40 so that the utility knife may be operated for bi-directional cutting.

The utility knife also includes a trigger 22 that is configured to be operated by a thumb of the user when the utility knife is held in a user's hand. The trigger 22 is operable to urge the blade holder 26 towards the slotted opening 58 to a cutting position. A first end of the trigger 22 protrudes from a trigger opening 21 in the housing 10 and a second end of the trigger 22 is configured to urge against the blade holder

26. In some embodiments, the trigger 22 is pivotally disposed on a pivot 24 and pivot slot 20 carried within the housing 10. A trigger latch or a blade carrier latch may be included to easily lock the blade 34 in either the exposed or retracted position if there was a need to keep the blade in one position for an extended period of time. The trigger latch would also allow for bi-directional cutting without a need for the user to maintain constant pressure on the trigger 22.

A biasing means may be provided to automatically move the blade holder 26 away from the slotted opening 58 when the trigger 22 is released to return the blade holder 26 to a stowed position. In the stowed position, the blade 34 carried by the blade holder 26 is retracted within the housing 10 so that a cutting edge of the blade 34 is not exposed. The biasing means may include a spring or other resilient material. In the non-limiting example shown the spring may be an L shaped spring having a first end 42 urged in abutment with a retaining slot 18 defined in an interior of the housing 10 and a second end 44 that is retained within a slot and retainer 32 of the blade carrier 26.

Preferably, the cutting face 11 of the elongate housing 10 is arcuate, so that the cutting face 11 may be operated against a surface to be cut by swiping the blade 34 protruding through the cutting face 11 across the surface to be cut. An outer surface of the handle, opposite the cutting face, may also have an ergonomic curvature 55. The ergonomic curvature 55 provides a palm rest 55 that is dimensioned to rest the outer surface of the handle in a palm of the user's hand when the utility knife is held by the one or more digits of the user's hand.

At least one lobe 64 may extend from an end of the cutting face 11. An indentation in the housing 10 subjacent to the lobe 64 provides a protective barrier between the utility knife handle and the surface to be cut by the knife. The trigger 22 may be pivotally disposed within the housing 10 so that a first end of the trigger 22 protrudes from a trigger opening 21 in the housing 10.

The blade holder 26 may be pivotally disposed within the housing 10. A second end of the trigger 22 may be urged against the blade holder 26 so that upon activation of the trigger 22 the blade holder 26 is rotated about its pivot and the blade extends through the slotted opening 58 in the cutting face 11. A hole 38 in the blade holder 26 and a corresponding hole 36 in the blade 34 may be received on a post 16 and pivotally retained on the post 16 by a fastener 62, such as a pin, bolt, or screw.

An aperture 60 may be defined in at least one of the lobes 64 to permit hanging the utility knife, such as in a storage area, a tool belt, a tether, and the like.

The elongate housing 10 may be made of any suitable material, such as metal, or a polyurethane plastic (ABS). The elongate housing 10 may be formed in joinable shell segments to define an interior cavity for receiving the blade carrier 26 and blade 34. One or more fasteners 62, such as a screw, may be received through a screw hole 48 to secure the shell segments to one or posts 14 within the housing. Guide pins 50 may also be provided to facilitate alignment of the shell segments by reception within a receiver 12 defined in an opposite shell segment.

To use the utility knife of the present invention a person grasps it in their dominant hand or the hand they would typically do manual their tasks. The utility knife is grasped so that the trigger 22 is to be on the same side as the thumb of that person's hand. The user may place their 2nd, 3rd, 4th and 5th fingers in the finger opening. Alternatively, the user may place their 2nd, 3rd, 4th fingers in the opening and their 5th finger may wrap and stabilize against the external

ergonomic edge. The user may also place their 2nd and 3rd fingers in the opening and wrap their 4th and 5th finger around the external ergonomic edge. The number of fingers to put in the opening depends on the size of the hand and what feels the most comfortable to that individual for a particular cutting task.

The user may then depress the trigger 22 with their thumb to extend the blade so as to expose the blade. When necessary, the user would release the trigger 22 to automatically permit the blade to return to its retracted position so that the blade is unexposed. The ergonomic shape permits the user to retain the utility knife in their hand and pick up items, grasp, type, lift, push with that same hand and assist their other hand with tasks, as needed, without having to take it off your hand.

The present invention allows a person to continue with the jobs they were performing by having the ability to use both hands and not having to set it down between manual tasks, thus saving time and increasing efficiency. The knife won't get lost or misplaced because doesn't need to put it down as frequently. The auto-retracting blade will decrease lacerations and other hand/wrist injuries to the user and others.

It should be understood, of course, that the foregoing relates to exemplary embodiments of the invention and that modifications may be made without departing from the spirit and scope of the invention as set forth in the following claims.

What is claimed is:

1. A utility knife, comprising:

- an elongate housing having a slotted opening defined in a cutting face of the elongate housing;
- a handle opening defined through a lateral face of the elongate housing, the handle opening configured to receive one or more digits of a user's hand;
- a blade holder retractably carried on a pivot disposed within the elongate housing for rotation of the blade holder to urge a blade, when carried by the blade holder, through the slotted opening thereby defining a cutting position of the blade holder; and
- a trigger pivotally connected to the elongate housing and configured to be operated by a thumb of the user when the utility knife is held in a user's hand, the trigger pivotally operable to urge the blade holder towards the slotted opening to the cutting position.

2. The utility knife of claim 1, further comprising:

- a biasing means in the elongate housing to move the blade holder away from the slotted opening when the trigger is released to return the blade holder to a stowed position.

3. The utility knife of claim 2, wherein the biasing means, comprises a spring having a first end urged in abutment with a retaining slot defined in an interior of the elongate housing and a second end that is retained within a retaining slot of the blade holder.

4. The utility knife of claim 1, wherein the cutting face of the elongate housing is arcuate.

5. The utility knife of claim 1, wherein an outer surface of a portion of the elongate housing defining the handle opening, opposite the cutting face, has an ergonomic curvature to rest in a palm of the user's hand when held by the one or more digits of the user's hand.

6. The utility knife of claim 5, the elongate housing further comprising:

- at least one lobe extending from an end of the cutting face.

7. The utility knife of claim 6, further comprising:

- an indentation in the elongate housing adjacent to the at least one lobe.



8. The utility knife of claim 1, wherein the trigger is pivotally disposed on a pivot pin within the elongate housing and a first end of the trigger protrudes from a trigger opening in the elongate housing and a second end of the trigger urges against the blade holder.

5

9. The utility knife of claim 1, further comprising:  
a blade carried by the blade holder.

10. A utility knife, comprising:

an elongate housing having a slotted opening defined in a cutting face generally parallel-with a longitudinal length of the elongate housing, a palm rest opposed to the cutting face;

10

a handle opening generally aligned with the cutting face of the elongate housing, the handle opening defined through a lateral face of the elongate housing and at least partially defined by the palm rest, the handle opening configured to receive one or more digits of a user's hand;

15

a blade holder retractably carried on a pivot disposed within the elongate housing for rotation of the blade holder about the pivot configured to urge a blade, when carried by the blade holder, through the slotted opening thereby defining a cutting position of the blade holder; and

20

a trigger pivotally connected to the elongate housing and configured to be operated by a thumb of the user when the utility knife is held in a user's hand, the trigger pivotally operable to rotationally urge the blade holder towards the slotted opening to the cutting position.

25

\* \* \* \* \*

30