



Europäisches Patentamt
European Patent Office
Office européen des brevets



(11) **EP 1 075 570 B1**

(12) **EUROPEAN PATENT SPECIFICATION**

(45) Date of publication and mention
of the grant of the patent:

18.12.2002 Bulletin 2002/51

(21) Application number: **00909192.7**

(22) Date of filing: **16.02.2000**

(51) Int Cl.7: **E02D 3/10**

(86) International application number:
PCT/EP00/01277

(87) International publication number:
WO 00/050696 (31.08.2000 Gazette 2000/35)

(54) **AN EQUIPMENT AND A METHOD FOR PARTIALLY DRYING A ZONE OF GROUND CONTAINING A LIQUID**

VORRICHTUNG SOWIE VERFAHREN ZUR TEILWEISEN TROCKNUNG EINES BEREICHES IM BODEN

EQUIPEMENT ET PROCEDE DESTINES AU SECHAGE PARTIEL D'UNE ZONE DU SOL CONTENANT UN LIQUIDE

(84) Designated Contracting States:
**AT BE CH CY DE DK ES FI FR GB GR IE IT LI LU
MC NL PT SE**

(30) Priority: **25.02.1999 US 257019**

(43) Date of publication of application:
14.02.2001 Bulletin 2001/07

(73) Proprietor: **Menard Soltraitement
91620 Nozay (FR)**

(72) Inventor: **COGNON, Jean-Marie
F-92330 Sceaux (FR)**

(74) Representative: **Lerner, François et al
5, rue Jules Lefèbvre
75009 Paris (FR)**

(56) References cited:
EP-A- 0 329 500 FR-A- 2 663 373

EP 1 075 570 B1

Note: Within nine months from the publication of the mention of the grant of the European patent, any person may give notice to the European Patent Office of opposition to the European patent granted. Notice of opposition shall be filed in a written reasoned statement. It shall not be deemed to have been filed until the opposition fee has been paid. (Art. 99(1) European Patent Convention).

Description

[0001] The invention relates to an assembly for partially drying a zone of a substantially non permeable (or weakly permeous) ground containing a liquid. The invention is also directed to a method for drying such a zone.

[0002] An equipment for drying a zone of ground weakly permeous to liquid, (especially water), is already known, see for example FR-A-2 663 373 and EP-A-329 500.

[0003] Such an equipment comprises :

- a substantially air-tight membrane, covering the zone of ground to be dried and comprising a peripheral sealing means for allowing a partial vacuum to be obtained under the membrane,
- an embankment permeous to water and disposed under the membrane, over the zone of ground to be dried,
- first drain tubes disposed substantially vertically in the zone of ground and in fluid communication with the permeable embankment,
- second drain tubes connected to a suction pump, those second drain tubes being laid substantially flat in the embankment and in fluid communication with the liquid collected in the first drain tubes, under the membrane.

[0004] Such an assembly including an air depressed membrane is already known, especially for reinforcing weak grounds impregnated with water and having a low permeability to water.

[0005] Such grounds are improper to receive buildings thereon.

[0006] For reinforcing such grounds and improving their mechanical strength, a partial vacuum is created under the membrane.

[0007] The permeable material of the embankment is typically sand. The sand is disposed on the zone of ground to be reinforced (i.e. a layer of weak clay).

[0008] An object of the invention is to propose a solution in connection with the following problems, (it is to be noted that in the following description, the liquid to be expelled from the ground is water, even if various other liquids could be concerned).

[0009] The problems to be solved include what follows:

- effectiveness of the fluid suction, whatever the fluid may be (water, air ...),
- speed of the ground compacting effect,
- optimizing the arrangement of the various tubes, drain tubes, suction means, for improving the yield,
- optimizing the height of the embankment for combining an efficient depression of air under the membrane and a height of embankment less than a critical height possibly involving a mechanical shearing

of the embankment.

[0010] So, according to the invention, the second drain tubes comprise a series of fluid input holes opened within the embankment for communicating with the fluid contained in said embankment, in order to have at least said collected liquid entered the second drain tubes and evacuated.

[0011] The air depression under the membrane can advantageously be obtained as follows:

- the air contained in the embankment is sucked through the holes of the second drain tubes which are not entirely and/or permanently immersed in the water to be expelled,
- the air contained in the embankment is sucked through third drain tubes horizontally disposed above the level of the second drain tubes.

[0012] Thus, the suction of air will be obtained from a larger area than in the prior art, within the embankment, while the liquid to be expelled (and air to be exhausted) are taken from said embankment which is partly filled with water (especially in its lower portion).

[0013] According to two other features of the invention:

- the second drain tubes comprise a series of drain tubes, and the distance between two such successive drain tubes of the series is about 5 to 25 times larger than the vertical distance (height) between the level of the series of second drain tubes and a maximum level of the liquid within the embankment,
- and the first drain tubes are separated from the second drain tubes, the liquid collected in the first drain tubes passing in the embankment before entering the second drain tubes.

[0014] Thus, the distribution of the drain tubes will be optimized as in the ground as in the embankment, while improving the yield and thus, the speed of the ground compacting effect.

[0015] According to a preferred complementary feature of the invention :

- the equipment further comprises complementary air suction tubes, for expelling air contained within the embankment and creating therein the air depression (in addition to, or instead of, the second drain tubes, the latter being then only reserved for sucking up the water),
- under the membrane, at least some of those air suction tubes are connected to the above-mentioned third drain tubes which are laid flat in the embankment and which comprise a series of fluid input holes for an input of fluid therein,
- the third drain tubes are disposed at a level above the level of the second drain tubes, in a zone of the

embankment which is unsaturated with liquid, and those third drain tubes are connected to an air suction means.

[0016] For further improving the yield of the equipment, an other advice is as follows :

- one of the third drain tubes is advantageously disposed substantially straight above one of the second drain tubes,
- and at least locally in the embankment, the third drain tubes are disposed every other time over the second drain tubes.

[0017] In connection with the method for drying a ground, as taught by the invention, it is recommended to proceed as follows:

- disposing first drain tubes substantially vertically into the zone of ground to be dried, for collecting in said first drain tubes at least a part of the liquid to be evacuated for drying the zone,
- substantially horizontally disposing second drain tubes above said zone of ground,
- disposing the second drain tubes within an embankment permeous to water, the embankment being disposed on the zone of ground to be dried and being in fluid communication with the first drain tubes,
- recovering the zone of ground to be dried and the embankment with a substantially air-tight membrane,
- creating a peripheral sealing at a periphery of said membrane for allowing an air depression to be obtained under the membrane, said membrane being crossed over by the second drain tubes,
- creating the air depression under the membrane, and expelling through the second drain tubes at least some of the liquid to be evacuated from the ground, the equipment being characterized in that the step of expelling the liquid comprises the steps of :
 - providing the second drain tubes with fluid input holes, and
 - expelling at least some of the liquid contained in the embankment, through said fluid input holes of the second drain tubes.

[0018] If the embankment is provided with the above-mentioned third drain tubes, it will be possible to partially or even entirely dissociate the suction of water (essentially, or only, through the second drain tubes) from the suction of air (essentially, or only, through the third drain tubes).

[0019] A detailed description of the invention will follow, with reference to the accompanying drawings in which :

- Figure 1 is a diagrammatic longitudinal section of a portion of the equipment located essentially over the zone of ground to be dried (line I-I of Figure 3),
- Figure 2 is a diagrammatic transversal section, along the line II-II of Figure 3,
- Figure 3 shows a diagrammatic view from over the assembly, at a reduced scale,
- Figure 4 is a complement of Figure 1 which shows more specifically the fluid suction system (liquid to be expelled and air to be exhausted),
- and Figures 5 and 6 show again the illustrations of Figures 1 and 2, while showing the « third drain tubes », more especially reserved for sucking air from under the membrane.

[0020] In Figure 1, reference 1 is the zone of ground to be reinforced, such as a layer of weak clay extending over a ground layer 3 permeous to the liquids. (A ground is considered as mechanically « weak » if its module of elasticity (E) is less than about 80 bars).

[0021] The ground 1 is a compressible ground typically located just near a river and in which the water is at the ground level or just below (one or a few meters deep). The ground 1 has a low permeability to water.

[0022] Above the zone of ground 1 is erected an embankment 5 made from a material permeous to the liquid to be exhausted, and thus permeous to air. The embankment is a draining layer for water.

[0023] Advantageously, the embankment is made of sand or of granular material compatible with the permeability to the fluids to be exhausted (air + water).

[0024] The layer 5 is overlaid with a membrane 7 which is (substantially) non permeable to liquid and airtight. The surface covered by the embankment and the membrane 7 determines the surface of ground to be reinforced, the limits of which are the peripheral limits (or border) of the membrane and of the embankment disposed thereunder.

[0025] The full depth (or height) « H » of the body 5 can be of about 20 cm to 60 cm and, in such a body, a partial air vacuum of about 60 KPa to 80 KPa can be obtained by using for example a pump referenced 11 in Figure 4.

[0026] The membrane 7 is advantageously a strong membrane made of rubber.

[0027] For obtaining the peripheral sealing of the membrane and thus creating the air depression thereunder, a trench 13 opened to the air is dug in the ground, along the perimeter of the ground zone 1. Then the trench is filled with a sealing material 15, such as a bentonitic mud. All the peripheral border 7a of the membrane 7 is then immersed into the sealing material 15.

[0028] For accelerating the compacting effect, vertical hole drain tubes 17 have been previously disposed in the weakly permeable layer 1.

[0029] For example, the substantially vertical drain tubes 17 are separated therebetween from about 2 meters to 6 meters along two perpendicular directions, as

it can be seen in Figures 1 and 2.

[0030] A borer or a drill can be used to do so.

[0031] The drain tubes can be porous tubes having strainers, or perforated tubes made of plastic material and having an inner diameter for example of about 50 mm, adapted to allow the liquid to be expelled from the ground 1 to enter therein through the fluid input holes 19.

[0032] The drain tubes 17 stop just above the underlying layer 3, especially if the layer 3 is a draining layer.

[0033] At the surface level, the vertical drain tubes 17 are opened for being in fluid communication with the granular body 5 (even if a protection prevents the material of the embankment from falling within the drain tubes).

[0034] All the more because of the air depression created in the layer 5, the water contained in the layer 1 rises up to the body 5. In the ground, the water is naturally accumulated in the drains 17 which are progressively filled with the liquid to be expelled.

[0035] In the granular embankment 5 are further laid horizontal second drain tubes 23 disposed at a higher level than the upper end of the drain tubes 17. Thus, drain tubes 17 and 23 are separated one from the other and are not connected therebetween.

[0036] Drain tubes 23 can be perforated tubes having the same diameter as the first drain tubes (for example 50 mm). They comprise fluid input holes 25.

[0037] Those holes 25 are staggered along at least the major length of the drain tubes under the membrane and are disposed on the periphery thereof. The diameter of the holes 25 is adapted to enter and exhaust the water (and possibly air) contained in the embankment 5 through said drain tubes 23 (if the zone of the granular body in which said second drain tubes extend is not fully impregnated (saturated) with water).

[0038] The second drain tubes 23 extend below the level 27 of the water risen within the embankment 5 (a stabilized situation of the equipment is supposed).

[0039] So, the drain tubes are (at least) partially immersed within the water to be expelled. The water level line 27 shows substantially the shape of the « climbing down curves » of said water in the embankment, due to the suction created by the pump assembly 11 which is connected to the drain tubes 23.

[0040] According to the invention, the distribution of the second drain tubes 23 is optimized:

[0041] Firstly, those drain tubes consist of a series of drain tubes disposed parallel one to the other, in a substantially horizontal plane, as it can be seen in Figures 1, 2 and 3.

[0042] Further, the distance « e » between two successive drain tubes (such as referenced 23a and 23b in Figure 3) is such as said distance is between five times and twenty-five times the vertical distance « h₁ » (see Figure 2) between the mid-level (referenced 230) of the series of the second drain tubes 23 and the maximal liquid level in the embankment (top of the curve 27, between two successive drain tubes of the series).

[0043] Preferably, the distance « e » will even be comprised five times and fifteen times the height « h₁ ».

[0044] So, a layer having a height « h₂ » of « dried » material 5 (or at least non saturated with water) will further be maintained between the maximal water rising level and the membrane 7.

[0045] For optimizing the air depression, the height « h₂ » will preferably be equal to at least 10 cm (for example comprised between substantially 10 cm and 30 cm).

[0046] According to a best mode, the perforated drain tubes 23 will have a diameter of about 5 cm.

[0047] The following conditions are further supposed

- 15 - permeability of the layer 5 of about 10⁻³ m/s ;
- suction pump means 11 (connected to all the drain tubes 23) having a water delivery of about 100 m³/h. Such a pump is supposed to be used for a surface of ground of about 3 000 m² ;
- 20 - the horizontal distance « e » between two successive drain tubes 23 is of about 2.5 m;
- the delivery by linear meter of drain tube is, in such a situation, considered as equal to substantially 20 to 25 x 10⁻⁶ m³ /m/s.

[0048] In such conditions, « h₁ » is comprised between substantially 10 cm and 20 cm (it is supposed that the two drain tubes selected for the example, such as 23a and 23b, are substantially identically operated).

[0049] Thus, the drain tubes 23 will suck up liquid from the embankment 5 and will be further used for creating the air depression within said granular body 5, above the liquid level.

[0050] Through their input holes 25, the drain tubes 23 will then typically aspirate a mixture of air and water coming from the body 5. Such a mixture will be separated in the pump means 11.

[0051] As it can be seen in Figures 1 to 3, the horizontal perforated drain tubes 23 pass air-tightly through the membrane 7 and are connected to one (or a plurality) of collector(s) such as referenced in 29. The collector(s) is connected to the pump equipment 11.

[0052] As disclosed in FR-B-2 663 373 (page 5, line 32 to page 8, line 31), the pump means 11 can especially comprise an air-tight box 31 comprising an input 31a which is connected to the collector(s) 29 in which circulate not only water, but also air.

[0053] For separating air from water, the box 31 includes a separation chamber 33.

[0054] Air accumulated in the higher portion of the chamber is sucked to the air pump 35 in a duct 37 provided with a one-way valve.

[0055] Near the bottom of the chamber 33, a water pump 39 expels the water contained in the ground and/or in the embankment 5. The water is directed to the expelling duct 41.

[0056] The sealed box 31 is closed, air-tight and adapted to resist to the air depression induced by the

pump 35.

[0057] The pump for water 39 is adapted for being intermittently operated.

[0058] The pump for air 35 can be a pump called « liquid ejector FLUXERO ® ».

[0059] For operating such a pump, a high speed jet of liquid is propelled.

[0060] An admission duct 45 supplies the pump 35 with water, in 43.

[0061] The admission duct 45 is connected to a water pump 47, the input of which is connected by a duct 49 to a water tank 51.

[0062] The water tank can consist of the top part of the trench 13 in which the volume of water 51 « floats » over the mud 15.

[0063] The output of the air vacuum pump 35 is connected to an expelling duct (water/air) 53 which opens in 55 above the water tank 51.

[0064] In Figure 4, the drain tubes means 17, 23 also comprise third drain tubes 57 disposed in the embankment 5 at a level higher than the mid-level 230 of the second drain tubes 23.

[0065] The third drain tubes 57 are perforated along at least the major portion of their length and extend in the embankments wherein they are substantially horizontally disposed (see Figures 5 and 6).

[0066] The drain tubes 57 comprise fluid input holes 59 adapted for entering (at least) air therein.

[0067] Preferably, the drain tubes 57 are disposed in the upper portion of the granular embankment, above the maximal level 27 of the liquid to be expelled, viz. in the portion « h_2 » of the body 5.

[0068] In the immediate vicinity of the lateral edge of the embankment 5, the drain tubes 57 are connected to tubes 61 already used in the prior art for expelling air (previously, those tubes were only engaged on a short distance through the membrane, into the embankment, and took off air by their opened free end, only).

[0069] The tubes 61 are connected to the pump 11, at the upper part thereof, above the level of liquid present therein. Thus, air accumulated at the top of chamber 33 can be exhausted through the duct 37 to the pump 35 (the phantom lines in Figure 4 show such an exhaustion).

[0070] Further, the second drain tubes 23 can be disposed a little bit lower in the embankment 5. Thus, those drain tubes will be substantially immersed in the water risen up from the ground 1.

[0071] In such a situation, the drain tubes 23 will substantially only contain water to be expelled by the pump, whereas the upper drain tubes 57 will substantially only contain air to be exhausted. If the disposition of Figures 1 and 2 is reproduced for the drain tubes 23, a mixture of air and

[0072] water will be expelled therethrough.

[0073] In Figure 6, it is to be noted that the third drain tubes 57 are disposed parallel to the second drain tubes, with a determined drain tube 57 just above a determined

drain tube 23.

[0074] Such a disposition induces a reduction of the embankment height and also a reduction of height between the second and the third drain tubes.

[0075] It is even advantageously suggested to dispose a determined third drain tube every other second drain tube, as shown in Figure 6, since the drain tubes 57 are more particularly reserved to exhaust the air from under the membrane, what improves the yield of such an exhaustion.

[0076] It is also to be noted that the invention as presently disclosed provides the following improvements:

- it is no more useful to dig wells into the ground to be dried for disposing therein, firstly, a porous tube within which was, secondly, engaged a water expelling duct (drain tube),
- it is useless to dispose a pump at the bottom of such wells, for drawing off water therefrom,
- it is useless to connect the abovementioned water expelling tubes to the horizontal drain tubes disposed within the embankment,
- it is now possible to improve the exhaust of air from the embankment (see for those items FR-B-2 663 373 and FR-B-2 627 202, especially).

[0077] In relation to the embankment, it is also to be noted that limiting the height thereof, while improving the yield of exhausting water and/or air, reduces the shearing stresses and thus a possible sliding of the embankment.

[0078] Further, in relation to the first and second drain tubes (17, 23), even if the advice is not to connect those tubes therebetween, it could be done while maintaining complementary holes through the wall of the second drain tubes, for directly taking off the fluid in the embankment (abovementioned holes 25).

40 Claims

1. An equipment for at least partially drying a zone of ground (1) containing a liquid, the equipment comprising:

- a substantially air-tight membrane (7), covering the zone of ground to be dried and comprising a peripheral sealing means (7a, 13) for allowing an air depression to be obtained under the membrane,
- a water permeable embankment disposed under the membrane (7), over the zone of ground to be dried,
- first drain tubes (17) disposed substantially vertically in the zone of ground and in fluid communication with the permeable embankment,
- second drain tubes (23, 29) connected to a suction pump (33, 35), the second drain tubes be-

ing laid substantially flat in the embankment and in fluid communication with the liquid collected in the first drain tubes, under the membrane, for evacuating through said second drain tubes the liquid collected from the ground,

characterized in that the second drain tubes (23) comprise a series of fluid input holes (25) opened within the embankment for communicating with the fluid contained in said embankment, in order to have at least said collected liquid entered the second drain tubes and evacuated.

2. The equipment of claim 1, **characterized in that** the second drain tubes (23) comprise a series of drain tubes, and the distance (e) between two such successive drain tubes (23a, 23b) of the series is about 5 to 25 times larger than the vertical distance between the level of the series of second drain tubes and a maximum level of the liquid within the embankment.

3. The equipment according to anyone of the preceding claims, **characterized in that** the first drain tubes (17) are separated from the second drain tubes (23), so that the liquid collected in the first drain tubes passes in the embankment (5) before entering the second drain tubes.

4. The equipment of anyone of claims 1 to 3, **characterized in that** the second drain tubes (23) are disposed at a level of the embankment (5) adapted for evacuating, through said second drain tubes (23), the liquid from the embankment, and air for obtaining the air depression under the membrane (7).

5. The equipment according to anyone of claims 1 to 3, further comprising:

- third drain tubes (57) laid substantially flat in the embankment, under the membrane (7), and comprising a series of fluid input holes (59) for an input of fluid therein,
- the third drain tubes being disposed at a level above the level of the second drain tubes (23), in a zone of the embankment which is unsaturated with liquid, and being connected to an air suction means (35).

6. The equipment of claim 5 **characterized in that** one of the third drain tubes (57) is disposed substantially straight above one of the second drain tubes (23),

7. The equipment according to claim 5 or claim 6, **characterized in that**, at least locally in the embankment (5), the third drain tubes (57) are disposed every other time over the second drain tubes

(23).

8. The equipment according to claim 1, **characterized in that**:

- it further comprises ducts (37, 61) connected to air suction means (35) for exhausting air contained under the membrane (7),
- at least some of said ducts (61) are connected, under the membrane, to third drain tubes (57) which are substantially horizontally disposed in the embankment (5), at a level above the level of the second drain tubes (23),
- and the second and third drain tubes (23, 57) comprise a series of fluid input holes (25, 59) opened within the embankment for entering therein fluid contained in said embankment.

9. The equipment according to claim 8, **characterized in that** :

- the second drain tubes (23) are disposed in a low zone of the embankment containing liquid to be evacuated,
- and the third drain tubes (57) are disposed in a high zone of the embankment for exhausting said air from the embankment.

10. A method for at least partially drying a zone of ground containing a liquid, the equipment comprising:

- disposing first drain tubes (17) substantially vertically into the zone of ground (1) to be dried, for collecting in said first drain tubes at least a part of the liquid to be evacuated for drying the zone,
- substantially horizontally disposing second drain tubes (23) above said zone of ground,
- disposing the second drain tubes (23) within an embankment (5) permeous to water, the embankment being disposed on the zone of ground to be dried and being in fluid communication with the first drain tubes (17),
- recovering the zone of ground to be dried and the embankment with a substantially air-tight membrane (7),
- creating a peripheral sealing (7a, 13) at a periphery of said membrane for allowing an air depression to be obtained under the membrane, said membrane being crossed over by the second drain tubes (23),
- creating the air depression under the membrane, and expelling through the second drain tubes (23) at least some of the liquid to be evacuated from the ground,

characterized in that the step of expelling the liq-

uid comprises the steps of

- providing the second drain tubes with fluid input holes (25), and
- expelling at least some of the liquid contained in the embankment, through said fluid input holes of the second drain tubes (23).

11. The method according to claim 10, **characterized in that** the steps of creating an air depression under the membrane and expelling the liquid from the ground comprise the steps of:

- disposing ducts (61) under the membrane, at a level above the level of the second drain tubes (23),
- having the membrane crossed over by said ducts (61), and connecting the ducts to a fluid suction means (33, 35), for creating the air depression under the membrane,
- having the second drain tubes (23) disposed in a low zone of the embankment containing the liquid to be expelled,
- the step of disposing the ducts (61) under the membrane comprising :
 - * connecting, under the membrane, at least some of said ducts to third drain tubes (57) comprising fluid input holes (59),
 - * disposing said third drain tubes (57) substantially horizontally in the embankment (5), while disposing the third drain tubes in a high part of the embankment which is unsaturated with liquid,
- and the step of disposing the second drain tubes (23) in the embankment comprises the step of disposing two successive second drain tubes (23a, 23b) at a relative distance (e) of about 5 to 25 times higher than the vertical distance between the second drain tubes (23) and the third drain tubes (57).

Patentansprüche

1. Einrichtung für das zumindest teilweise Trocknen einer Bodenzone (1), die eine Flüssigkeit enthält, wobei die Einrichtung aufweist:

- eine im wesentlichen luftdichte Membran (7), die die zu trocknende Bodenzone abdeckt und eine Dichteinrichtung (7a, 13) am Rand aufweist, um die Erzielung eines Luftunterdrucks unter der Membran zu erlauben,
- eine wasserdurchlässige Aufschüttung, die unter der Membran (7) über der zu trocknenden Bodenzone angeordnet ist,

- erste Entwässerungsrohre (17), die im wesentlichen vertikal in der Bodenzone angeordnet sind und in Fluidkommunikation mit der durchlässigen Auffüllung steht,
- zweite Entwässerungsrohre (23, 29) unter der Membran, die mit einer Saugpumpe (33, 35) verbunden sind, wobei die zweiten Entwässerungsrohre im wesentlichen flach in der Auffüllung liegen und in Fluidkontakt mit der Flüssigkeit stehen, die in den ersten Entwässerungsrohren gesammelt wurde, für die Evakuierung der von dem Boden gesammelten Flüssigkeit durch die zweiten Entwässerungsrohre,

dadurch gekennzeichnet, daß die zweiten Entwässerungsrohre (23) eine Reihe von Fluideingangslöchern (25) aufweisen, die sich innerhalb der Auffüllung öffnen, für die Kommunikation mit dem Fluid, das in der Auffüllung enthalten ist, um zu erreichen, daß zumindest die gesammelte Flüssigkeit in die zweiten Entwässerungsrohre eintritt und evakuiert wird.

2. Einrichtung nach Anspruch 1, **dadurch gekennzeichnet, daß** die zweiten Entwässerungsrohre (23) eine Reihe von Entwässerungsrohren aufweisen und der Abstand (e) zwischen zwei aufeinanderfolgenden Entwässerungsrohren (23a, 23b) der Reihe etwa 5- bis 25-mal größer ist als der vertikale Abstand zwischen dem Niveau der Reihe von zweiten Entwässerungsrohren und einem maximalen Niveau der Flüssigkeit innerhalb der Auffüllung.

3. Einrichtung nach einem der vorherigen Ansprüche, **dadurch gekennzeichnet, daß** die ersten Entwässerungsrohre (17) von den zweiten Entwässerungsrohren (23) getrennt sind, so daß die Flüssigkeit, die in den ersten Entwässerungsrohren gesammelt wird, in die Auffüllung (5) geleitet wird, bevor sie in die zweiten Entwässerungsrohre eintritt.

4. Einrichtung nach einem der Ansprüche 1 bis 3, **dadurch gekennzeichnet, daß** die zweiten Entwässerungsrohre (23) auf einem Niveau der Auffüllung (5) angeordnet sind, das an die Evakuierung durch die zweiten Entwässerungsrohre (23) der Flüssigkeit von der Auffüllung und an die Evakuierung der Luft für das Erreichen des Luftunterdrucks unter der Membran (7) angepaßt ist.

5. Einrichtung nach einem der Ansprüche 1 bis 3, die weiterhin aufweist:

- dritte Entwässerungsrohre (57), die im wesentlichen flach in der Auffüllung unter der Membran (7) liegen und eine Reihe von Fluideingangslöchern (59) für die Eingabe eines Fluids hierin aufweisen,

- wobei die dritten Entwässerungsrohre bei einem Niveau oberhalb des Niveaus der zweiten Entwässerungsrohre (23) in einer Zone der Auffüllung angeordnet sind, die mit Flüssigkeit nicht gesättigt ist und mit einer Luftsaugereinrichtung (35) verbunden sind. 5
6. Einrichtung nach Anspruch 5, **dadurch gekennzeichnet, daß** eines der dritten Entwässerungsrohre (57) im wesentlichen geradlinig oberhalb eines der zweiten Entwässerungsrohre (23) angeordnet ist. 10
7. Einrichtung nach Anspruch 5 oder Anspruch 6, **dadurch gekennzeichnet, daß** zumindest lokal in der Auffüllung (5) die dritten Entwässerungsrohre (57) jedes zweite Mal über den zweiten Entwässerungsrohren (23) angeordnet sind. 15
8. Einrichtung nach Anspruch 1, **dadurch gekennzeichnet, daß:** 20
- sie weiterhin Kanäle (37, 61) aufweist, die mit einer Luftsaugereinrichtung (35) verbunden sind, für das Absaugen der Luft, die unter der Membran (7) enthalten ist, 25
 - zumindest einige der besagten Kanäle (61) unter der Membran mit dritten Entwässerungsrohren (57) verbunden ist, die im wesentlichen horizontal in der Auffüllung (5) bei einem Niveau oberhalb des Niveaus der zweiten Entwässerungsrohre (23) angeordnet sind, 30
 - und die zweiten und dritten Entwässerungsrohre (23, 57) eine Reihe von Fluideingangslöchern (25, 59) aufweisen, die sich innerhalb der Auffüllung öffnen für das Eintreten von Fluid, das in der Auffüllung enthalten ist. 35
9. Einrichtung nach Anspruch 8, **dadurch gekennzeichnet, daß:** 40
- die zweiten Entwässerungsrohre (23) in einer unteren Zone der Auffüllung der Zone angeordnet sind, die Flüssigkeit enthält, die zu evakuieren ist, 45
 - und die dritten Entwässerungsrohre (57) in einer oberen Zone der Auffüllung angeordnet sind, für das Ablassen der Luft von der Auffüllung. 50
10. Verfahren für das zumindest teilweise Trocknen einer Bodenzone, die eine Flüssigkeit enthält, wobei die Einrichtung aufweist: 55
- Anordnen von ersten Entwässerungsrohren (17) im wesentlichen vertikal innerhalb der Bodenzone (1), die getrocknet werden soll, für das Sammeln zumindest eines Teils der für das
- Trocknen der Zone zu evakuierenden Flüssigkeit in den ersten Entwässerungsrohren,
- Anordnen zweiter Entwässerungsrohre (23) im wesentlichen horizontal oberhalb der Bodenzone,
 - Anordnen der zweiten Entwässerungsrohre (23) innerhalb einer Auffüllung (5), die für Wasser durchlässig ist, wobei die Auffüllung auf der Bodenzone, die zu trocknen ist, angeordnet ist und in Fluidkontakt mit den ersten Entwässerungsrohren (17) ist,
 - Abdecken der Bodenzone, die getrocknet werden soll, und der Auffüllung mit einer im wesentlichen luftdichten Membran (7),
 - Erzeugen einer Dichtung (7a, 13) an einem Rand der besagten Membran, um zu erlauben, daß ein Luftunterdruck unter der Membran erhalten wird, wobei die zweiten Entwässerungsrohre (23) durch die Membran verlaufen,
 - Erzeugen des Luftunterdrucks unter der Membran und Ausstoßen zumindest eines Teils der von dem Boden zu evakuierenden Flüssigkeit durch die zweiten Entwässerungsrohre (23),
- dadurch gekennzeichnet, daß** der Schritt des Ausstoßens der Flüssigkeit die Schritte aufweist:
- Zurverfügungstellen von zweiten Entwässerungsrohren mit Fluideingangslöchern (25) und
 - Ausstoßen zumindest eines Teils der in der Auffüllung enthaltenen Flüssigkeit durch die besagten Fluideingangslöcher der zweiten Entwässerungsrohre (23).
11. Verfahren nach Anspruch 10, **dadurch gekennzeichnet, daß** die Schritte des Erzeugens eines Luftunterdruckes unter der Membran und des Ausstoßens der Flüssigkeit von dem Boden die Schritte aufweist:
- Anordnen von Kanälen (61) unter der Membran auf einem Niveau oberhalb des Niveaus der zweiten Entwässerungsrohre (23),
 - wobei die Kanäle (61) durch die Membran verlaufen und die Kanäle mit einer Fluidsaugereinrichtung (33, 35) verbunden werden für das Erzeugen des Luftunterdruckes unter der Membran,
 - wobei die zweiten Entwässerungsrohre (23) in einer niedrigen Zone der Auffüllung angeordnet werden, die die auszustoßende Flüssigkeit enthält,
 - wobei der Schritt des Anordnens der Kanäle (61) unter der Membran aufweist:
 - * Verbinden zumindest eines Teils der Kanäle mit dritten Entwässerungsrohren (57), die unter der Membran Fluideingangslö-

- cher (59) aufweisen,
- * Anordnen der dritten Entwässerungsröhre (57) im wesentlichen horizontal in der Auffüllung (5), während die dritte Entwässerungsröhre in einem hohen Teil der Auffüllung angeordnet werden, der mit Flüssigkeit nicht gesättigt ist,

- und den Schritt des Anordnens der zweiten Entwässerungsröhre (23) in der Auffüllung den Schritt des Anordnens von zwei aufeinanderfolgenden zweiten Entwässerungsröhren (23a, 23b) mit einem relativen Abstand (e), der etwa 5- bis 25-mal größer als der vertikale Abstand zwischen den zweiten Entwässerungsröhren (23) und den dritten Entwässerungsröhren (57) ist, aufweist.

Revendications

1. Equipement pour assécher au moins partiellement une zone de sol (1) contenant un liquide, l'équipement comprenant:

- une membrane sensiblement imperméable à l'air (7) couvrant la zone de terrain à assécher et comprenant des moyens d'étanchéité périphérique (7a, 13) pour permettre d'obtenir une dépression d'air sous la membrane,
- un remblai perméable à l'eau (5) disposé sous la membrane (7), par dessus la zone de terrain à assécher,
- des premiers tubes de drainage (17) disposés sensiblement verticalement dans la zone de terrain et en communication fluide avec le remblai perméable,
- des seconds tubes de drainage (23, 29) reliés à une pompe d'aspiration (33, 35), les seconds tubes de drainage s'étendant sensiblement à plat dans le remblai et étant en communication fluide avec le liquide collecté dans les tubes de drainage, sous la membrane, pour évacuer à travers ces seconds tubes de drainage le liquide collecté depuis le terrain,

caractérisé en ce que les seconds tubes de drainage (23) comprennent une série d'orifices d'entrée de fluide (25) ouverts dans le remblai pour communiquer avec le fluide obtenu dans ce remblai, de manière qu'au moins le dit liquide collecté entre dans les seconds tubes de drainage et soit évacué,

2. Equipement selon la revendication 1, **caractérisé en ce que** les tubes de drainage (23) comprennent

une série de tubes de drainage et la distance (e) entre dans deux tels tubes de drainage successifs (23a et 23b) de la série est d'environ 5 à 15 fois plus importante que la distance verticale entre le niveau d'élévation où se situe la série de seconds tubes de drainage et un niveau d'élévation maximum du liquide dans le remblai.

3. Equipement selon l'une quelconque des revendications précédentes, **caractérisé en ce que** les premiers tubes de drainage (17) sont écartés des seconds tubes de drainage (23), de sorte que le liquide collecté dans les premiers tubes de drainage passe dans le remblai avant d'entrer dans les seconds tubes de drainage.

4. Equipement selon l'une quelconque des revendications 1 à 3, **caractérisé en ce que** les seconds tubes de drainage (23) sont disposés à un niveau d'élévation dans le remblai (5) adapté pour évacuer, à travers ces seconds tubes de drainage (23), le liquide contenu dans le remblai et l'air, de manière à obtenir une dépression d'air sous la membrane (7)

5. Equipement sur l'une quelconque des revendications 1 à 3, comprenant en outre:

- des troisièmes tubes de drainage (57) s'étendant sensiblement à plat dans le remblai, sous la membrane, et comprenant une série d'orifices d'entrée de fluide (59) pour permettre à du fluide d'entrer dans ces troisièmes tubes,
- les troisièmes tubes de drainage sont disposés à un niveau d'élévation inférieur au niveau des seconds tubes de drainage (23), dans une zone du remblai qui est insaturée en liquide, les troisièmes tubes de drainage étant reliés à des moyens d'aspiration d'air (35).

6. Equipement selon la revendication 5, **caractérisé en ce que** l'un des troisièmes tubes de drainage (57) est disposé sensiblement juste au dessus de l'un des seconds tubes de drainage (23).

7. Equipement selon la revendication 5 et la revendication 6, **caractérisé en ce qu'**au moins localement dans le remblai (5), les troisièmes tubes de drainage (57) sont disposés une fois sur deux juste au dessus des seconds tubes de drainage (23).

8. Equipement selon la revendication 1, **caractérisé en ce que:**

- il comprend en outre des conduits (37, 61) reliés au moyen d'aspiration d'air (35) pour expulser l'air présent sous la membrane (7),

- certains au moins des dits conduits (61) sont reliés, sous la membrane, à des troisièmes tubes de drainage (57) qui sont sensiblement horizontalement disposés dans le remblai (5), à un niveau d'élévation supérieur à celui des seconds tubes de drainage (23),
5
- et les seconds et troisièmes tubes de drainage (23, 57) comprennent une série d'orifices d'entrée de fluide (25 59) ouverts dans le remblai pour permettre à du fluide contenu dans ce remblai d'entrer dans les dits tubes.
10

9. Equipement selon la revendication 8, caractérisé en ce que:

- les seconds tubes de drainage (23) sont disposés dans une partie basse du remblai contenant du liquide à évacuer;
20
- les troisièmes tubes de drainage (57) sont disposés dans une partie haute du remblai pour évacuer l'air hors de ce remblai.
25

10. Méthode pour au moins partiellement assécher une zone de terrain contenant un liquide, la méthode comprenant les étapes suivantes:

- disposer des premiers tubes de drainage (17) sensiblement verticalement dans la zone de terrain (1) à assécher, pour collecter dans ces premiers tubes de drainage une partie au moins du liquide à évacuer pour assécher la zone,
30
- disposer sensiblement horizontalement des seconds tubes de drainage (23) au dessus de la dite zone de terrain,
35
- disposer les seconds tubes de drainage (23) dans un remblai (5) perméable à l'eau, ce remblai étant disposé sur la zone de terrain à assécher et étant en communication fluide avec les premiers tubes de drainage (17),
40
- recouvrir la zone de terrain à assécher et le remblai par une membrane sensiblement étanche à l'air (7),
45
- créer un joint périphérique (7a, 13) en périphérie de la membrane pour permettre d'obtenir une dépression d'air sous la membrane, cette membrane étant traversée par les seconds tubes de drainage (23),
50
- créer la dépression d'air sous la membrane et retirer à travers les seconds tubes de drainage (23) une partie au moins du liquide à évacuer
55

hors du terrain,

caractérisée en ce que l'étape retrait du liquide comprend les étapes de:

- réaliser les seconds tubes de drainage avec des orifices d'entrée de fluide,
- retirer une partie au moins du liquide contenu dans le remblai à travers ces orifices d'entrée de fluide des seconds tubes de drainage (23).

11. Méthode selon la revendication 10, caractérisée en ce que les étapes de création d'une dépression d'air sous la membrane et de retrait du liquide du terrain comprennent les étapes de:

- disposer des conduits (61) sous la membrane, à un niveau d'élévation inférieur à celui des seconds tubes de drainage (23),
- faire traverser la membrane par les dits conduits (61) et relier ces conduits à des moyens d'aspiration de fluide (33, 35), pour créer la dépression d'air sous la membrane,
- obtenir une disposition des seconds tubes de drainage (23) dans une partie inférieure du remblai contenant le liquide à retirer,
- l'étape consistant à disposer les conduits (61) sous la membrane comprenant les étapes de:
 - relier sous la membrane, certains au moins des conduits à des troisièmes tubes de drainage (57) comprenant des orifices d'entrée de fluide (59),
 - disposer les troisièmes tubes de drainage (57) sensiblement horizontalement dans le remblai (5) tout en disposant les troisièmes tubes de drainage dans une partie haute du remblai qui est insaturée en liquide,
- et l'étape consistant à disposer les seconds tubes de drainage (23) dans le remblai comprend une étape consistant à disposer deux seconds tubes de drainage successif (23a, 23b) avec un espacement (e) environ 5 à 25 fois supérieur à la distance verticale entre les seconds tubes de drainage (23) et les troisièmes tubes de drainage (57).

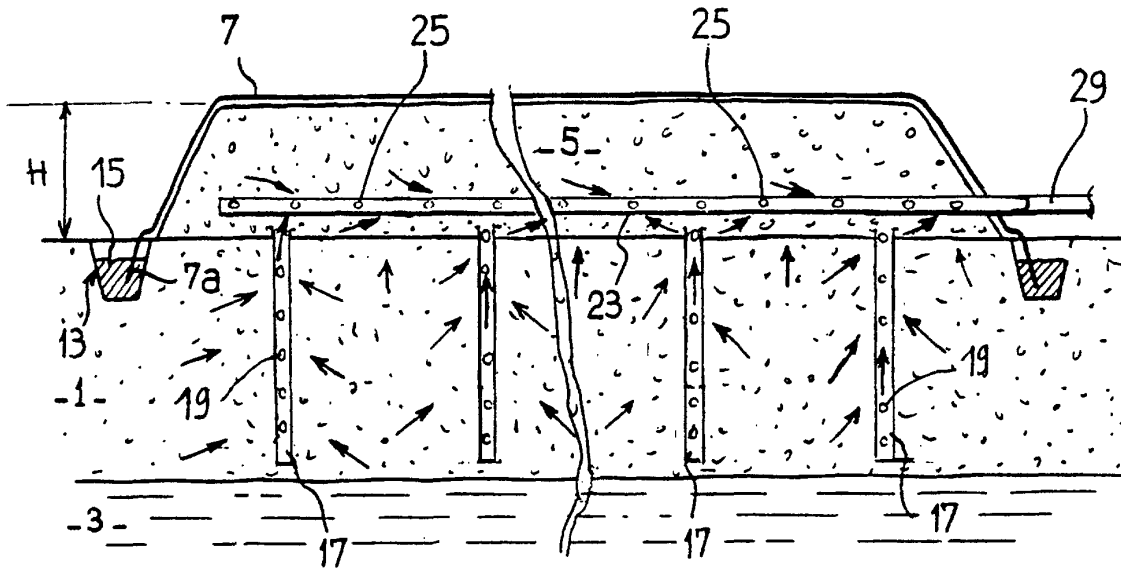

FIG. 1

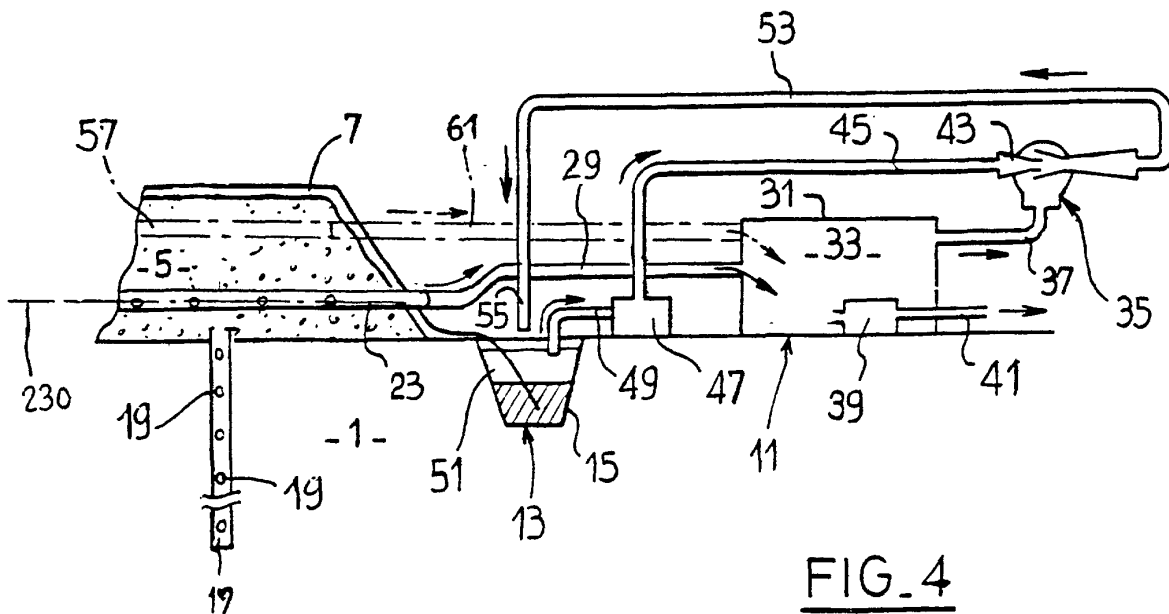

FIG. 4

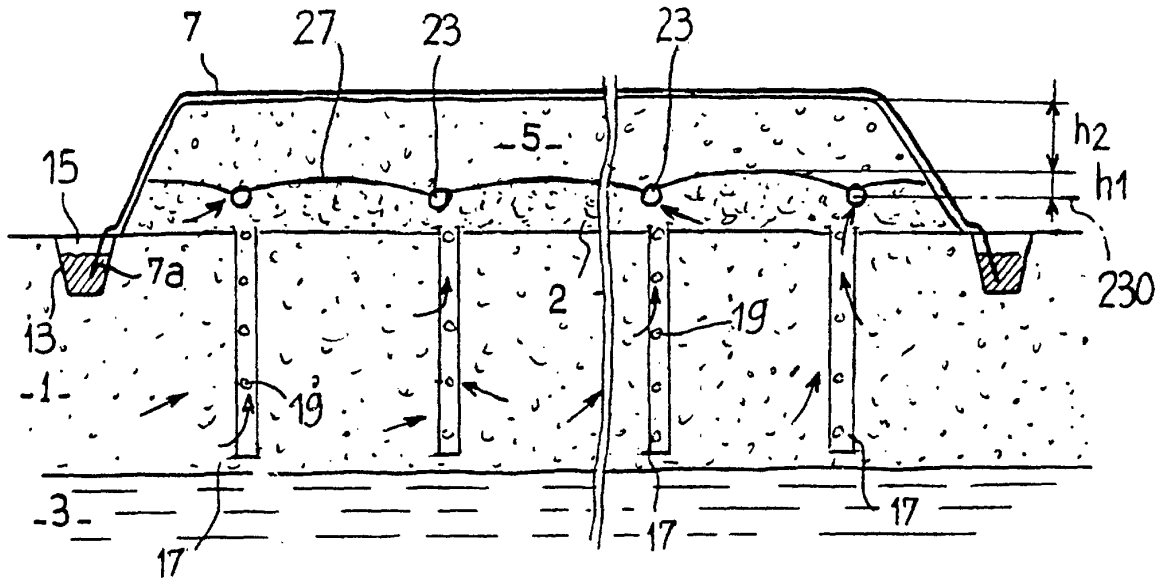

FIG. 2

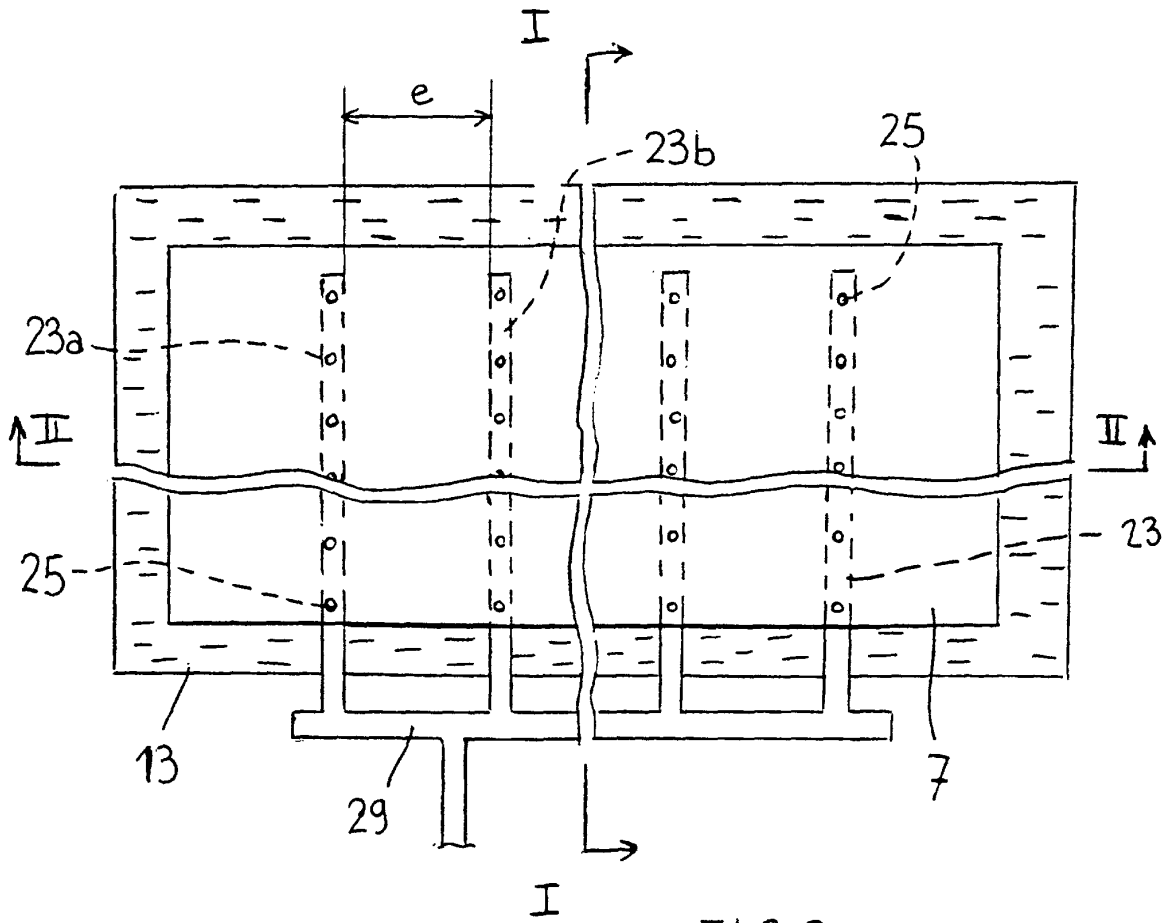

FIG. 3

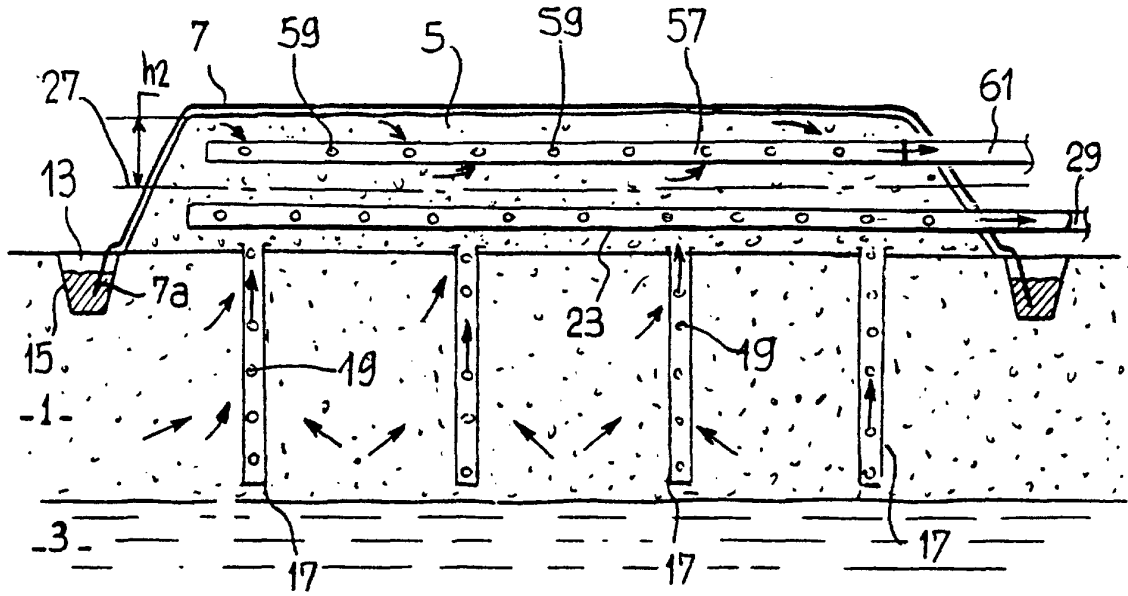

FIG. 5

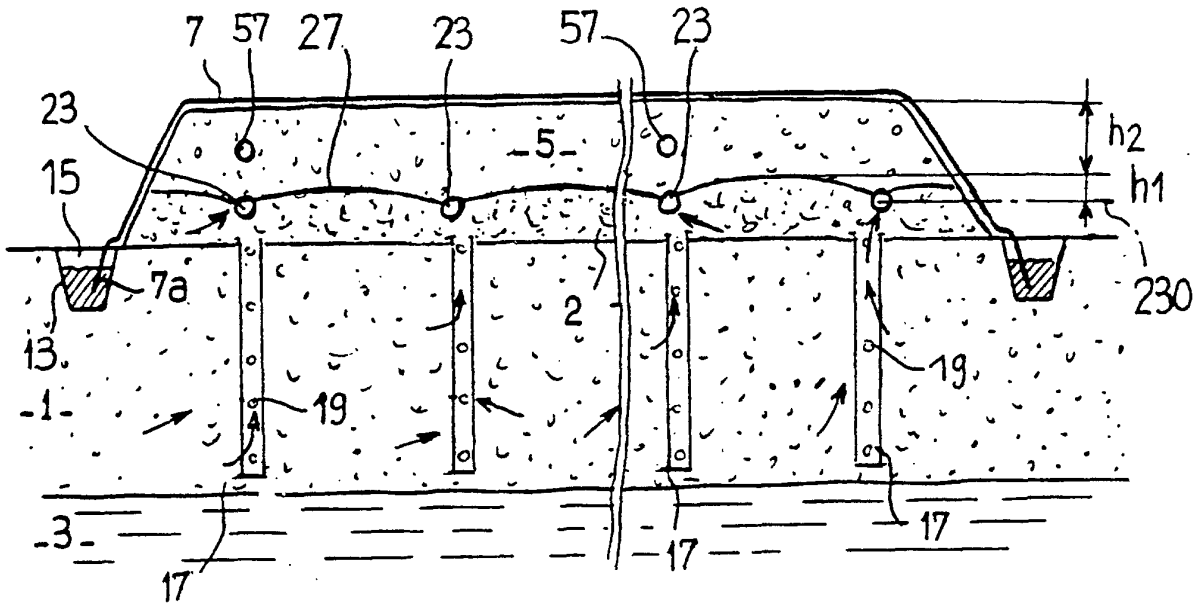

FIG. 6