



**EUROPEAN PATENT APPLICATION**

Application number : **92305088.4**

Int. Cl.<sup>5</sup> : **B28B 1/08, B28B 1/29, B28B 13/02**

Date of filing : **03.06.92**

Priority : **06.06.91 GB 9112186**

Date of publication of application : **09.12.92 Bulletin 92/50**

Designated Contracting States : **DE FR GB**

Applicant : **Durham, John Anthony Douglas**  
**34 Boscobel Place**  
**London SW1 (GB)**

Applicant : **Golmohamad, Zabiholah Asadolah**  
**35 Cambridge Avenue**  
**New Malden, Surrey (GB)**

Inventor : **Durham, John Anthony Douglas**  
**34 Boscobel Place**  
**London SW1 (GB)**  
 Inventor : **Golmohamad, Zabiholah Asadolah**  
**35 Cambridge Avenue**  
**New Malden, Surrey (GB)**

Representative : **Williams, Trevor John et al**  
**J.A. KEMP & CO. 14 South Square Gray's Inn**  
**London WC1R 5LX (GB)**

**Method and apparatus for laying a surface material on a prefabricated concrete slab.**

A device for spreading a smooth topping layer of plaster or mortar mix on hollow core prefabricated concrete slab, comprises a feed bin and a smoothing plate attached to the hollow core casting machine. The device spreads the plaster or mortar mix onto the concrete slab immediately behind the casting machine before the concrete sets so that the vibrations of the casting machine cause the plaster or mortar mix to bond to the concrete slab. Very accurate control of the thickness of the concrete slab can be achieved by levelling off the topping layer.

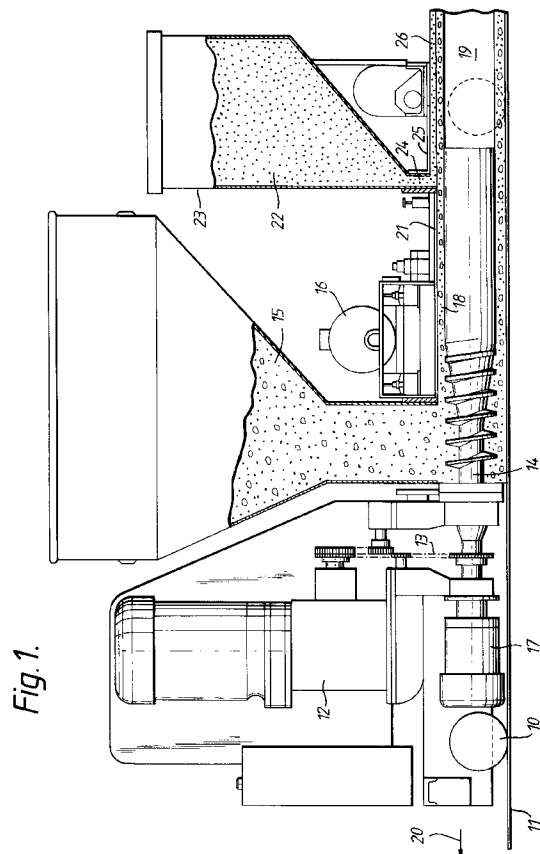

The present invention relates to an apparatus whereby a layer of surface material, more especially plaster or mortar mix, can be provided on a prefabricated concrete slab of indeterminate length.

Machines known as concrete hollow core production machines are used throughout the world to make an internationally recognised standard of precast concrete slab. A typical slab is usually cast in lengths of around 100 linear metres with a width of 1.2 metres. A series of hollow cores running the full length of the slab are formed in the cross section of a slab. Reinforcing wires or steel reinforcing bars are placed centrally between the hollow cores. An accurate mould or casting bed supports the hollow core casting machine. The machine, with 4 wheels, sits astride the casting bed on guide rails precisely aligned to the bed. Concrete is fed into the machine which moves down the bed as it slowly forces the concrete mix from one end into a precisely formed preset slab section. Whilst the soffit, or underside of the cast slab is generally very flat, the top surface of the slab tends to undulate and have a honeycombed surface.

If a high quality finish is required on the top of the slab a second independent machine is used to coat the slab top with a smooth and flat mortar mix. This machine is generally used when the slab has set some 10-12 hours after the concrete slab has been made.

According to the present invention there is provided a surface material laying apparatus for use with a concrete slab fabricator, of the type which moves relative to a stationary bed leaving a preformed slab behind it, the laying apparatus comprising:

a feed hopper for holding plaster or mortar mix, said feed hopper having a throat for directing said plaster or mortar mix onto said preformed slab,

means to maintain said feed hopper a predetermined distance behind said slab fabricator, and

a smoothing member adapted to be attached to the slab fabricator behind the feed hopper relative to the direction of travel of the slab fabricator, for smoothing the surface material deposited onto said slab by said feed hopper into a topping layer.

The present invention also provides a combination of a concrete slab fabricator of the type which moves relative to a stationary bed leaving a preformed slab behind it; and a surface material laying apparatus as described above.

The present invention further provides a method of fabricating a concrete slab, the method comprising the steps of;

providing a stationary bed and a casting machine of the type which moves relative to a stationary bed leaving a preformed slab behind it;

operating the machine to fabricate a concrete slab; and

as the machine moves, spreading a surface material on the slab close behind the machine, before

the concrete cures, to form a topping layer.

Yet further, the present invention provides a concrete slab having a main part formed by vibrating and compacting a concrete mix on a molding bed and a topping layer of surface material bonded to one surface of said main part by the vibrations used to form said main part.

The surface material is preferably a plaster or mortar mix.

By the addition of a feed hopper and a smoothing plate attached to the hollow core casting machine the mortar mix can be introduced on to the cast slab shortly after it is formed by the casting machine. By using a simple 4 wheeled trolley, free-wheeling behind the casting machine and resting on the same guide rails as the casting machine and moved, as necessary by machine operatives, masons with a hand or mechanically operated tamping and levelling device can accurately "float off" the plaster mix. This ensures a precise and consistent overall thickness of the completed concrete slab with its mortar mix topping.

The plaster/mortar mix is preferably introduced into a separate feed hopper set close behind, but spaced from, the main concrete feed hopper. The base of the hopper is a narrow open uninterrupted throat across the full width of the casting machine. Close behind the casting machine the plaster mix flows by gravity through the throat of the mortar feed hopper and falls onto the cast concrete. The residual vibration of the casting machine concrete mix vibrators serving to thoroughly bond the plaster mix onto the cast concrete below.

The cast concrete and the plaster mix set at the same time and can be cut up into small sections, as required, after approximately 8-12 hours of curing time.

In order that the invention may be more readily understood, the following description is given, merely by way of example, reference being made to the accompanying drawings, in which:-

Figure 1 is a cross section of a typical hollow core production machine with addition of the feed hopper and smoothing plate;

Figure 2 is a cross section of a typical slab produced by a hollow core casting machine;

Figure 3 is a cross section of a typical slab produced by a hollow core casting machine with the bonded plaster mix;

Figure 4 is perspective view of the 4 wheeled levelling trolley;

Figure 5 shows an alternative embodiment of the invention; and

Figure 6 shows a further alternative embodiment of the invention.

Referring now to Fig. 1 there is illustrated a typical cross section of a hollow core casting machine. The machine sits via 4 wheels (10) on a casting bed rail (11). A series of drive motors and gear boxes (12) ro-

tate, via chains (13), a series of screws (14). The machine remains stationary whilst the concrete mix is fed into the hopper (15). The screws are then rotated mechanically and the vibrator motors (16) & (17) are started up. The mix is forced through the moulding chamber (18) and compacted, forming into the required slab section (19). Thereafter the machine screws itself out of the compacted mix and thus moves in the direction of the arrow (20), in other words away from the compacted and cast slab which remains stationary on the casting bed.

Immediately the machine moves away from the compacted slab (21) a standard mortar mix (22) eg 1 part cement to 3 parts sand with appropriate water content to allow the mix to flow, is poured in the feed hopper (23). The mix immediately flows gravitationally via a throat (24) directly on the top of the cast concrete slab (19). A smoothing trowel (25) levels and smooths the plaster mix (26) which flows continuously from the hopper (23) as the machine moves away from the compacted slab (19) that it has 'screwed' itself out of.

The vibration produced by the vibrators (16) & (17) effectively bonds the plaster mix (26) onto the cast concrete slab (19), and also ensures even flow of mortar from the hopper.

Figure 2 shows a typical cast concrete slab section as it leaves the casting machine. In this instance 6 holes, or hollow cores, are shown (27). The cores can be round, square or oval to suit the required design. The top surface (28) can, if the manufacturing machine is in excellent working order, be flat; however depending on variations in the concrete mix consistency, wear of machine etc, the top is very often randomly undulating.

Figure 3 shows the same slab type section as Figure 2, with the complete topping mix (26) bonded onto the top of the cast concrete slab (19).

Figure 4 shows a typical freewheeling trolley resting via 4 wheels (29) onto casting bed rails (11). The rails in turn affixed to the continuous casting bed (30). Once the concrete mix (19) and the mortar mix (26) are bonded the levelling trolley is pushed by hand or mechanically moved to straddle the area requiring finishing, usually some 1-3m away from the continuously moving casting machine (1).

A tamping base (31) precisely defines the top finish level required for the topping mix (26). The base (31) is rigidly fixed but adjustable for height to the outer wheels (29). This enables the trolley to be adapted to finish off various heights of cast slab and mortar mixes. The inside face of the tamping base (32) is completely separated by an air gap (33) from the top edge of the mortar mix (34). This allows the whole levelling trolley to be freely moved up and down the casting bed (3) at any time without restrictions.

A straddle bar (35) holds the two tamping bases (31) each side of the casting bed rails (3).

A levelling bar (36), which can either be operated

by hand or mechanically vibrated is slid manually or mechanically backwards and forwards across the two tamping bases (31) straddling the casting bed (30). At all times the levelling bar (36) is kept in constant contact with the base (31).

In this way the plaster mix (26) is precisely trowelled off to give an exact overall thickness of cast slab and mortar as shown in the cut away section of the completed slab (26). The final touch up of the trowelled mortar mix is effected by a mason with a hand trowel following behind the levelling trolley.

Figure 5 shows a revised topping machine which has certain advantages over the device described with reference to Figure 1.

In the apparatus of Figure 5, the only casting machine is now separated from the hollow core casting machine by a distance in the range of from 500 to 1500 mm, preferably 500 to 800 mm. However, it is still physically attached each side of the frame by means 4. Thus, the hollow core machine pulls the topping machine along the bed as it casts its slab. There is thus no separate motive force for the revised topping machine.

The machine rests on four wheels 7 which free wheel on the same rails as the cast machine uses.

As the slab of concrete is extruded or cast by the hollow core machine, at a distance of approximately 500-1500 mm from where the casting machine leaves the stationary cast slab on the bed, the mortar mix 8 feeds onto the top of the cast slab 9. As the mortar mix is some distance away from the casting machine it is necessary to vibrate the hopper of the topping machine to ensure that a smooth flow of mortar mix leaves the hopper continuously. The vibrator is shown as 3.

Whilst in the first described embodiment the vibration of the casting machine was sufficient to 'flow' the mortar mix along the cast bed without additional vibration in this embodiment there is still enough residual vibration in the slab from the casting machine to ensure a proper bond of the mortar mix on the freshly cast hollow core slab, even with the topping machine placed some 50-80cm from the vibrators of the casting machine.

The topping machine is now a separate independent machine and thus needs counter-weights to ensure that it is firmly located over the casting bed rails 5 and 6.

A similar smoothing trowel 2 is used on the revised topping machine to ensure that mix 1 flows evenly over the surface of the cast slab.

The advantages of this embodiment are:

1. The casting machine is independent of the topping machine, thus repairs of either apparatus are easier if either breaks down.
2. The cast slab produced by the casting machine can be visually inspected before the topping mix is applied. Thus, if there is a problem with the cast

slab, for example 'collapsing cores' the machine can be stopped to rectify the problem; whereas previously the topping mortar mix hid the problem.

3. Various slab thicknesses require the topping mix. Because the topping machine is now independent of the casting machine there is no need to convert each casting machine to carry the topping machine. Any sized casting machine can be adapted to pull the topping mix machine with it. The height of the topping mix can always be adapted to suit the height of the hollow core slab to be cast.

Finally, the trowelling apparatus which follows independently behind the topping machine is still applicable.

Figure 6 shows a further alternative embodiment in which the topping machine is physically separate from the slab fabricator. The topping machine is provided with a motor 61 to propel it and is controlled by controller 62 to maintain a set distance, in the range of 500 to 1500 mm, behind the slab fabricator. The controller 62 is supplied with information on the position of the slab fabricator and topping machine by position sensors 63 and 64. This embodiment provides the same advantages as that of Figure 5.

## Claims

1. A surface material laying apparatus for use with a concrete slab fabricator, of the type which moves relative to a stationary bed leaving a preformed slab (21) behind it, the laying apparatus comprising:

a feed hopper (23) for holding plaster or mortar mix, said feed hopper having a throat for directing said plaster or mortar mix onto said preformed slab,

means to maintain said feed hopper a predetermined distance behind said slab fabricator, and

a smoothing member (25) adapted to be attached to the slab fabricator behind the feed hopper relative to the direction of travel of the slab fabricator, for smoothing the surface material (26) deposited onto said slab (21) by said feed hopper into a topping layer.

2. A laying apparatus according to claim 1 wherein said distance maintaining means comprise attachment means adapted directly to attach said laying device to said slab fabricator.

3. A laying apparatus according to claim 1 wherein said distance maintaining means comprise attachment means (4) adapted to attach said laying apparatus to said slab fabricator spaced a sub-

stantial distance, preferably in the range of from 500 to 1500 mm, behind said fabricator.

4. A laying apparatus according to claim 3 further comprising feed hopper vibrator means to ensure smooth flow of surface material from said feed hopper.

5. A laying apparatus according to claim 1 further comprising means to move said apparatus along said slab while spreading surface material thereon.

6. A laying apparatus according to any one of claims 1 to 5, further comprising additional smoothing means (36) for smoothing the top surface of said topping layer.

7. A laying apparatus according to claim 6, wherein said additional smoothing means comprises a trolley, adapted to run on rails (11) parallel to the base of said stationary bed, for providing a tamping base (31) to define the desired top surface (28) of said topping layer to permit tamping and levelling to smooth off said topping layer to said desired surface.

8. A laying apparatus according to claim 7, including a mechanically operated tamping and levelling device.

9. A laying apparatus according to claim 6, 7 or 8, wherein said additional smoothing means is connected to said laying apparatus by coupling means that are non-transmissive of vibrations.

10. A combination of a concrete slab fabricator of the type which moves relative to a stationary bed leaving a preformed slab behind it and an apparatus according to any one of the preceding claims.

11. A combination according to claim 10, wherein said fabricator comprises a hollow core casting machine.

12. A combination according to claim 10 or 11, wherein said fabricator includes means for generating vibrations to compact the concrete slab and bond said surface material to the slab.

13. A method of fabricating a concrete slab, the method comprising the steps of;

providing a stationary bed and a casting machine of the type which moves relative to a stationary bed leaving a preformed slab behind it;

operating the machine to fabricate a concrete slab; and as the machine moves, spreading

a surface material on the slab close behind the machine, before the concrete cures, to form a topping layer.

- 14.** A method according to claim 13 wherein said surface material is spread onto the slab immediately behind the casting machine. 5
- 15.** A method according to claim 13 wherein said surface material is spread onto the slab a substantial distance, preferably in the range of from approximately 500 to 800 mm, behind the casting machine. 10
- 16.** A method according to claim 13, 14 or 15 further comprising the additional step of smoothing the surface material before it sets to provide a smooth upper surface to said topping layer. 15
- 17.** A method according to claim 13, 14, 15 or 16 wherein said casting machine which is provided includes means for producing vibrations and wherein said operating step includes operating the means for producing vibrations to vibrate the concrete to compact it and to bond the surface material to the concrete slab. 20  
25
- 18.** A concrete slab having a main part formed by vibrating and compacting a concrete mix on a molding bed and a topping layer of surface material bonded to one surface of said main part by the vibrations used to form said main part. 30
- 19.** A concrete slab fabricated by the combination of any one of claims 10 to 12, or according to the method of any of claims 13 to 17. 35

40

45

50

55

Fig. 1.

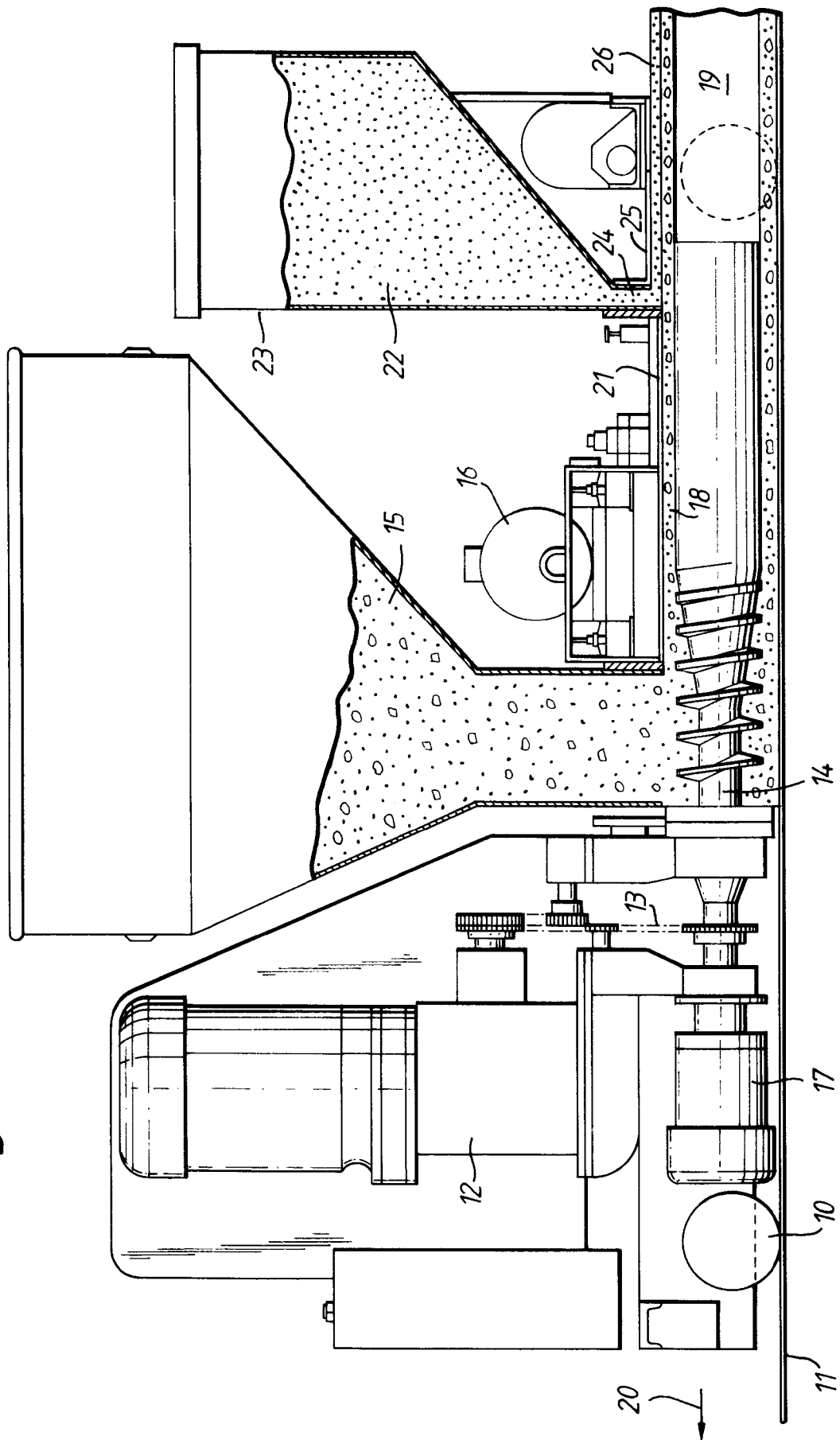

*Fig. 2.*

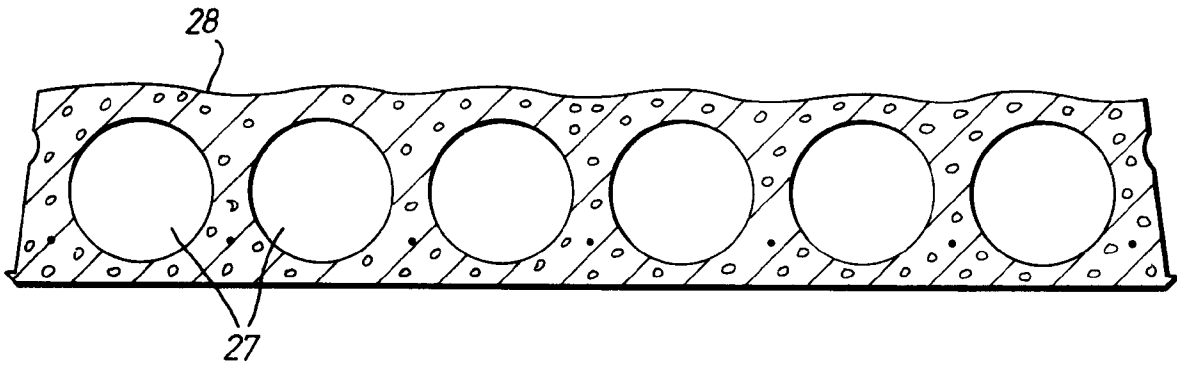

*Fig. 3.*

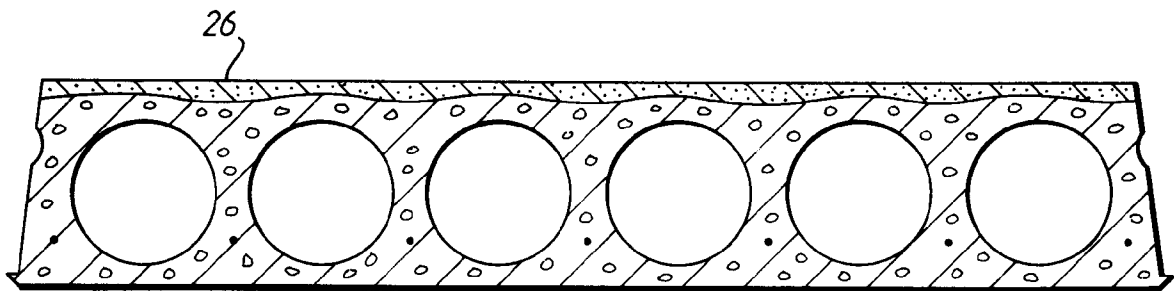

Fig. 4.

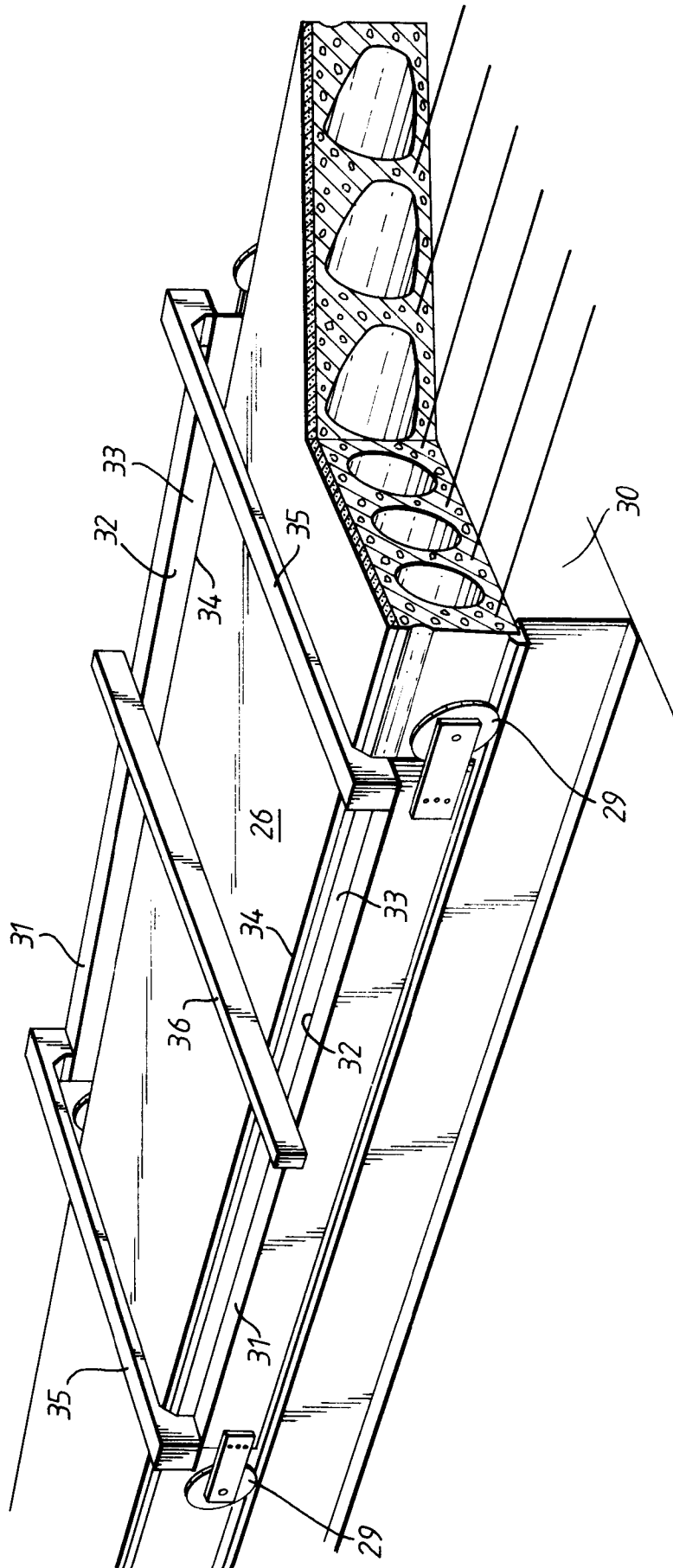



Fig. 5.

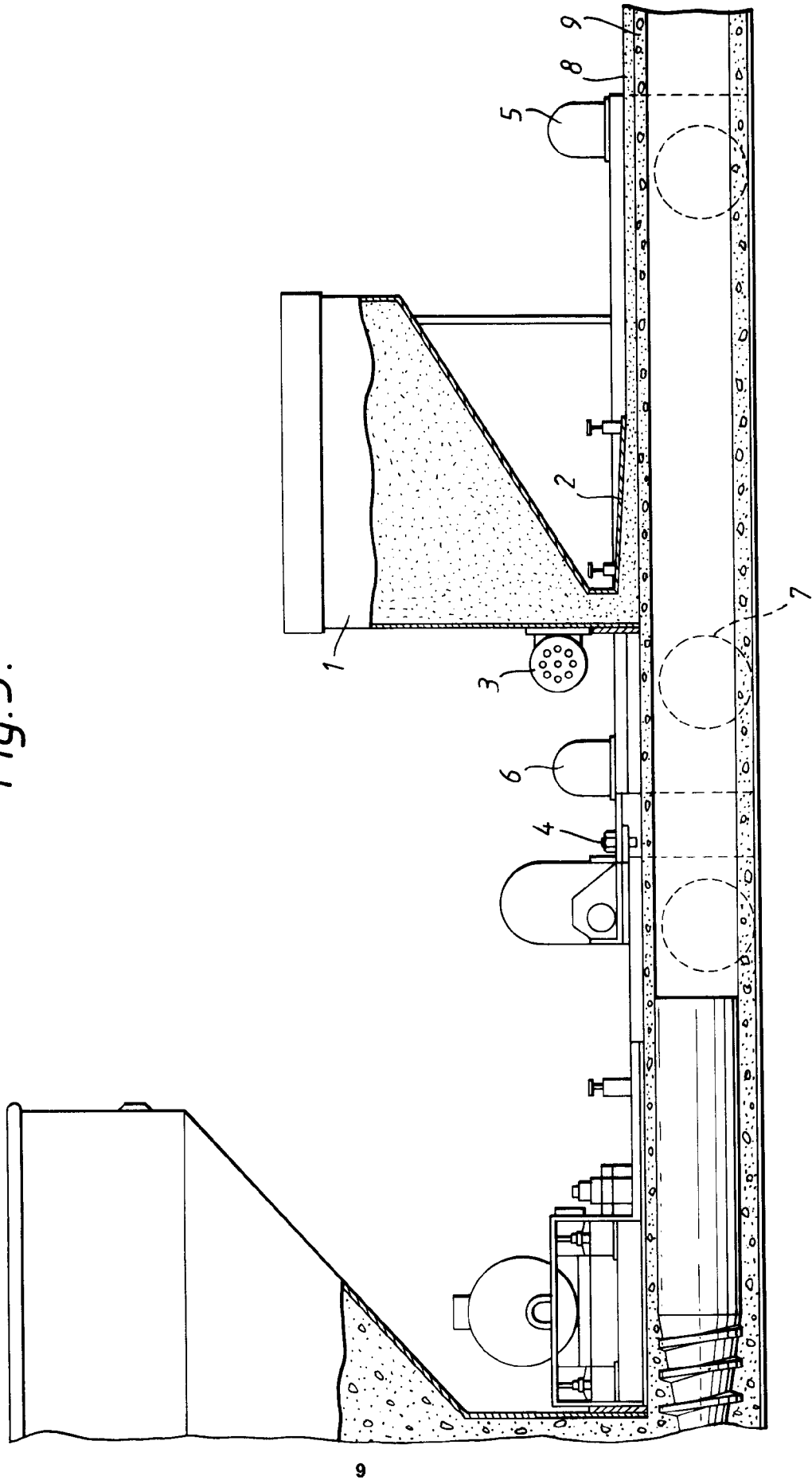
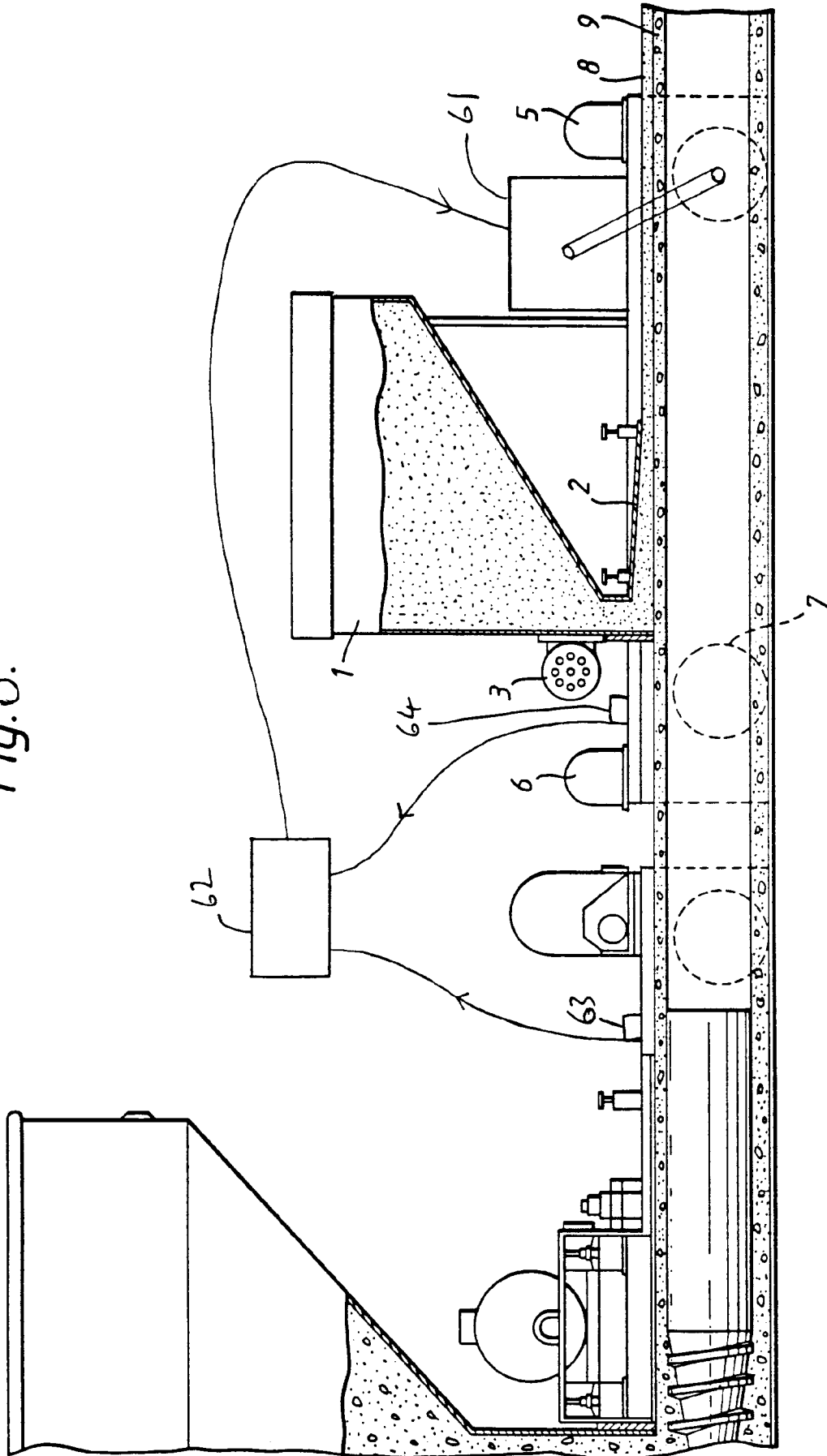

Fig. 6.





European Patent  
Office

EUROPEAN SEARCH REPORT

Application Number

EP 92 30 5088

DOCUMENTS CONSIDERED TO BE RELEVANT			
Category	Citation of document with indication, where appropriate, of relevant passages	Relevant to claim	CLASSIFICATION OF THE APPLICATION (Int. Cl.5)
X	US-A-4 229 153 (H. D. HIGHT, JR)  * the whole document, in particular col.3 1,15-18, col.5 1,52-68, col.14 1,6-35, fig. 4-6,14,15 *  ---	1-5, 10-19	B2881/08 B2881/29 B28813/02
X	US-A-4 280 800 (C. B. BUNN)  * the whole document, in particular col.1 1,6-9, col.1 1,29-42 *  ---	1-5,10, 13-16, 18,19	
X	GB-A-1 007 965 (K. L. VON BODDIEN)  * the whole document *	1,5-10, 13-19	
A	---	2,3	
A	BE-A-500 557 (W. DAUWE)  * the whole document *	1-5, 10-19	
A	US-A-4 330 242 (G. PUTTI)  * the whole document, in particular col.1 1,29-33 *  ---	1,6-10, 13,16-19	TECHNICAL FIELDS SEARCHED (Int. Cl.5)  B28B E01C
A	GB-A-1 402 317 (LARSEN & NIELSON CONSULTOR A/S) * the whole document *  -----	6-8	
The present search report has been drawn up for all claims			
Place of search THE HAGUE		Date of completion of the search 07 SEPTEMBER 1992	Examiner GOURIER P. A.
<p><b>CATEGORY OF CITED DOCUMENTS</b></p> <p>X : particularly relevant if taken alone                  Y : particularly relevant if combined with another document of the same category                  A : technological background                  O : non-written disclosure                  P : intermediate document</p> <p>T : theory or principle underlying the invention                  E : earlier patent document, but published on, or after the filing date                  D : document cited in the application                  L : document cited for other reasons                  .....                  &amp; : member of the same patent family, corresponding document</p>			

EPO FORM 1503 03.82 (P0601)