



US008442331B2

(12) **United States Patent**
King et al.

(10) **Patent No.:** **US 8,442,331 B2**
(45) **Date of Patent:** ***May 14, 2013**

(54) **CAPTURING TEXT FROM RENDERED DOCUMENTS USING SUPPLEMENTAL INFORMATION**

(75) Inventors: **Martin Towle King**, Vashon Island, WA (US); **Dale L. Grover**, Ann Arbor, MI (US); **Clifford A. Kushler**, Lynnwood, WA (US); **James Quentin Stafford-Fraser**, Cambridge (GB)

(73) Assignee: **Google Inc.**, Mountain View, CA (US)

(*) Notice: Subject to any disclaimer, the term of this patent is extended or adjusted under 35 U.S.C. 154(b) by 0 days.

This patent is subject to a terminal disclaimer.

(21) Appl. No.: **12/542,816**

(22) Filed: **Aug. 18, 2009**

(65) **Prior Publication Data**

US 2010/0177970 A1 Jul. 15, 2010

Related U.S. Application Data

(63) Continuation of application No. 11/096,704, filed on Apr. 1, 2005, now Pat. No. 7,599,580, which is a continuation-in-part of application No. 11/004,637, filed on Dec. 3, 2004, now Pat. No. 7,707,039.

(60) Provisional application No. 60/657,309, filed on Feb. 28, 2005, provisional application No. 60/655,697,

(Continued)

(51) **Int. Cl.**

G06K 9/72 (2006.01)

G06K 9/22 (2006.01)

(52) **U.S. Cl.**

USPC **382/229**; 382/313

(58) **Field of Classification Search** 382/115, 382/176, 181, 187, 190, 209, 229, 305, 306, 382/313-314; 707/707, E17.058; 715/200, 715/206; 345/179; 178/18.01, 18.03, 19.01, 178/19.05

See application file for complete search history.

(56) **References Cited**

U.S. PATENT DOCUMENTS

3,899,687 A 8/1975 Jones
4,052,058 A 10/1977 Hintz

(Continued)

FOREIGN PATENT DOCUMENTS

EP 0424803 5/1991
EP 0544434 6/1993

(Continued)

OTHER PUBLICATIONS

U.S. Appl No. 60/201,570, Bengston.

(Continued)

Primary Examiner — Daniel Mariam

(74) *Attorney, Agent, or Firm* — McDonnell Boehnen Hulbert & Berghoff LLP

(57) **ABSTRACT**

A system for processing a text capture operation is described. The system receives text captured from a rendered document in the text capture operation. The system also receives supplemental information distinct from the captured text. The system determines an action to perform in response to the text capture operation based upon both the captured text and the supplemental information.

60 Claims, 5 Drawing Sheets

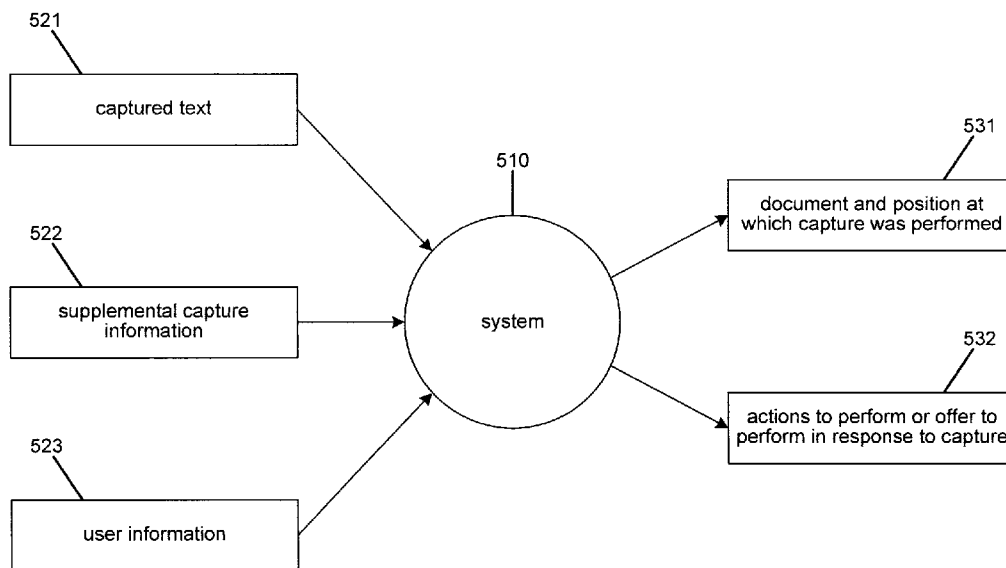

(56)

References Cited

U.S. PATENT DOCUMENTS

4,065,778 A	12/1977	Harvey	5,465,325 A	11/1995	Capps et al.
4,135,791 A	1/1979	Govignon	5,465,353 A	11/1995	Hull et al.
4,358,824 A	11/1982	Glickman et al.	5,467,425 A	11/1995	Lau et al.
4,526,078 A	7/1985	Chadabe	5,481,278 A	1/1996	Shigematsu et al.
4,538,072 A	8/1985	Immler et al.	5,485,565 A	1/1996	Saund et al.
4,553,261 A	11/1985	Froessl	5,488,196 A	1/1996	Zimmerman et al.
4,610,025 A	9/1986	Blum et al.	5,499,108 A	3/1996	Cotte et al.
4,633,507 A	12/1986	Cannistra et al.	5,500,920 A	3/1996	Kupiec
4,636,848 A	1/1987	Yamamoto et al.	5,500,937 A	3/1996	Thompson-Rohrlich
4,713,008 A	12/1987	Stocker et al.	5,502,803 A	3/1996	Yoshida et al.
4,716,804 A	1/1988	Chadabe	5,512,707 A	4/1996	Ohshima
4,748,678 A	5/1988	Takeda et al.	5,517,331 A	5/1996	Murai et al.
4,776,464 A	10/1988	Miller et al.	5,517,578 A	5/1996	Altman et al.
4,804,949 A	2/1989	Faulkerson	5,522,798 A	6/1996	Johnson et al.
4,805,099 A	2/1989	Huber	5,532,469 A	7/1996	Shepard et al.
4,829,453 A	5/1989	Katsuta et al.	5,533,141 A	7/1996	Futatsugi et al.
4,829,872 A	5/1989	Topic et al.	5,539,427 A	7/1996	Bricklin et al.
4,890,230 A	12/1989	Tanoshima et al.	5,541,419 A	7/1996	Arackellian
D306,162 S	2/1990	Faulkerson et al.	5,543,591 A	8/1996	Gillespie et al.
4,901,364 A	2/1990	Faulkerson et al.	5,550,930 A	8/1996	Berman et al.
4,903,229 A	2/1990	Schmidt et al.	5,555,363 A	9/1996	Tou et al.
4,914,709 A	4/1990	Rudak	5,563,996 A	10/1996	Tchao
4,941,125 A	7/1990	Boyne	5,568,452 A	10/1996	Kronenberg
4,947,261 A	8/1990	Ishikawa et al.	5,570,113 A	10/1996	Zetts
4,949,391 A	8/1990	Faulkerson et al.	5,574,804 A	11/1996	Olschafskie et al.
4,955,693 A	9/1990	Bobba	5,581,276 A	12/1996	Cipolla et al.
4,958,379 A	9/1990	Yamaguchi et al.	5,581,670 A	12/1996	Bier et al.
4,968,877 A	11/1990	McAvinney et al.	5,581,681 A	12/1996	Tchao et al.
5,107,256 A	4/1992	Ueno et al.	5,583,542 A	12/1996	Capps et al.
5,136,687 A	8/1992	Edelman et al.	5,583,543 A	12/1996	Takahashi et al.
5,142,161 A	8/1992	Brackmann	5,583,980 A	12/1996	Anderson
5,146,404 A	9/1992	Calloway et al.	5,590,219 A	12/1996	Gourdol
5,146,552 A	9/1992	Cassorla et al.	5,590,256 A	12/1996	Tchao et al.
5,157,384 A	10/1992	Greanias et al.	5,592,566 A	1/1997	Pagallo et al.
5,159,668 A	10/1992	Kaasila	5,594,469 A	1/1997	Freeman et al.
5,168,147 A	12/1992	Bloomberg	5,594,640 A	1/1997	Capps et al.
5,168,565 A	12/1992	Morita	5,594,810 A	1/1997	Gourdol
5,179,652 A	1/1993	Rozmanith et al.	5,595,445 A	1/1997	Bobry
5,185,857 A	2/1993	Rozmanith et al.	5,596,697 A	1/1997	Foster et al.
5,201,010 A	4/1993	Deaton et al.	5,600,765 A	2/1997	Ando et al.
5,202,985 A	4/1993	Goyal	5,602,376 A	2/1997	Coleman et al.
5,203,704 A	4/1993	McCloud	5,602,570 A	2/1997	Capps et al.
5,212,739 A	5/1993	Johnson	5,608,778 A	3/1997	Partridge, III
5,229,590 A	7/1993	Harden et al.	5,625,711 A	4/1997	Nicholson et al.
5,231,698 A	7/1993	Forcier	5,684,891 A	11/1997	Tanaka et al.
5,243,149 A	9/1993	Comerford et al.	5,708,825 A	1/1998	Sotomayor
5,247,285 A	9/1993	Yokota et al.	5,724,521 A	3/1998	Dedrick
5,251,106 A	10/1993	Hui	5,724,985 A	3/1998	Snell et al.
5,251,316 A	10/1993	Anick et al.	5,732,214 A	3/1998	Subrahmanyam
5,252,951 A	10/1993	Tannenbaum et al.	5,732,227 A	3/1998	Kuzunuki et al.
RE34,476 E	12/1993	Norwood	5,734,923 A	3/1998	Sagawa et al.
5,272,324 A	12/1993	Blevins	5,737,507 A	4/1998	Smith
5,288,938 A	2/1994	Wheaton	5,745,116 A	4/1998	Pisutha-Armond
5,301,243 A	4/1994	Olschafskie et al.	5,748,805 A	5/1998	Withgott et al.
5,347,295 A	9/1994	Agulnick et al.	5,748,926 A	5/1998	Fukuda et al.
5,347,306 A	9/1994	Nitta	5,752,051 A	5/1998	Cohen
5,347,477 A	9/1994	Lee	5,754,308 A	5/1998	Lopresti et al.
5,355,146 A	10/1994	Chiu et al.	5,754,939 A	5/1998	Herz et al.
5,360,971 A	11/1994	Kaufman et al.	5,756,981 A	5/1998	Roustaei et al.
5,367,453 A	11/1994	Capps et al.	5,764,794 A	6/1998	Perlin
5,371,348 A	12/1994	Kumar et al.	5,767,457 A	6/1998	Gerpheide et al.
5,377,706 A	1/1995	Huang	5,768,418 A	6/1998	Berman et al.
5,398,310 A	3/1995	Tchao et al.	5,768,607 A	6/1998	Drews et al.
5,404,442 A	4/1995	Foster et al.	5,774,357 A	6/1998	Hoffberg et al.
5,404,458 A	4/1995	Zetts	5,774,591 A	6/1998	Black et al.
5,418,684 A	5/1995	Koenck et al.	5,777,614 A	7/1998	Ando et al.
5,418,717 A	5/1995	Su et al.	5,781,662 A	7/1998	Mori et al.
5,418,951 A	5/1995	Damashek	5,781,723 A	7/1998	Yee et al.
5,423,554 A	6/1995	Davis	5,784,061 A	7/1998	Moran et al.
5,430,558 A	7/1995	Sohaehi et al.	5,784,504 A	7/1998	Anderson et al.
5,438,630 A	8/1995	Chen et al.	5,796,866 A	8/1998	Sakurai et al.
5,444,779 A	8/1995	Daniele	5,798,693 A	8/1998	Engellenner
5,452,442 A	9/1995	Kephart	5,798,758 A	8/1998	Harada et al.
5,454,043 A	9/1995	Freeman	5,799,219 A	8/1998	Moghadam et al.
5,462,473 A	10/1995	Sheller	5,805,167 A	9/1998	van Cruyningen
			5,809,172 A	9/1998	Melen
			5,809,267 A	9/1998	Moran et al.
			5,809,476 A	9/1998	Ryan
			5,815,577 A	9/1998	Clark

5,818,965 A	10/1998	Davies	6,031,525 A	2/2000	Perlin
5,821,925 A	10/1998	Carey et al.	6,033,086 A	3/2000	Bohn
5,822,539 A	10/1998	van Hoff	6,036,086 A	3/2000	Sizer et al.
5,825,943 A	10/1998	DeVito et al.	6,038,342 A	3/2000	Bernzott et al.
5,832,474 A	11/1998	Lopresti et al.	6,040,840 A	3/2000	Koshiba et al.
5,832,528 A	11/1998	Kwatinetz et al.	6,042,012 A	3/2000	Olmstead et al.
5,837,987 A	11/1998	Koenck et al.	6,044,378 A	3/2000	Gladney
5,838,326 A	11/1998	Card et al.	6,049,034 A	4/2000	Cook
5,838,889 A	11/1998	Booker	6,049,327 A	4/2000	Walker et al.
5,845,301 A	12/1998	Rivette et al.	6,052,481 A	4/2000	Grajski et al.
5,848,187 A	12/1998	Bricklin et al.	6,053,413 A	4/2000	Swift et al.
5,852,676 A	12/1998	Lazar	6,055,333 A	4/2000	Guzik et al.
5,861,886 A	1/1999	Moran et al.	6,055,513 A	4/2000	Katz et al.
5,862,256 A	1/1999	Zetts et al.	6,057,844 A	5/2000	Strauss
5,862,260 A	1/1999	Rhoads	6,057,845 A	5/2000	Dupouy
5,864,635 A	1/1999	Zetts et al.	6,061,050 A	5/2000	Allport et al.
5,864,848 A	1/1999	Horvitz et al.	6,064,854 A	5/2000	Peters et al.
5,867,150 A	2/1999	Bricklin et al.	6,066,794 A	5/2000	Longo
5,867,597 A	2/1999	Peairs et al.	6,069,622 A	5/2000	Kurlander
5,867,795 A	2/1999	Novis et al.	6,072,494 A	6/2000	Nguyen
5,880,411 A	3/1999	Gillespie et al.	6,072,502 A	6/2000	Gupta
5,880,731 A	3/1999	Liles et al.	6,075,895 A	6/2000	Qiao et al.
5,880,743 A	3/1999	Moran et al.	6,078,308 A	6/2000	Rosenberg et al.
5,884,267 A	3/1999	Goldenthal et al.	6,081,621 A	6/2000	Ackner
5,889,236 A	3/1999	Gillespie et al.	6,081,629 A	6/2000	Browning
5,889,523 A	3/1999	Wilcox et al.	6,085,162 A	7/2000	Cherny
5,889,896 A	3/1999	Meshinsky et al.	6,088,484 A	7/2000	Mead
5,890,147 A	3/1999	Peltonen et al.	6,088,731 A	7/2000	Kiraly et al.
5,893,095 A	4/1999	Jain et al.	6,092,038 A	7/2000	Kanevsky et al.
5,893,126 A	4/1999	Drews et al.	6,092,068 A	7/2000	Dinkelacker
5,893,130 A	4/1999	Inoue et al.	6,094,689 A	7/2000	Embry et al.
5,895,470 A	4/1999	Pirolli et al.	6,095,418 A	8/2000	Swartz et al.
5,899,700 A	5/1999	Williams et al.	6,097,392 A	8/2000	Leyerle
5,905,251 A	5/1999	Knowles	6,098,106 A	8/2000	Philyaw et al.
5,907,328 A	5/1999	Brush, II et al.	6,104,401 A	8/2000	Parsons
5,913,185 A	6/1999	Martino et al.	6,104,845 A	8/2000	Lipman et al.
5,917,491 A	6/1999	Bauersfeld	6,107,994 A	8/2000	Harada et al.
5,920,477 A	7/1999	Hoffberg et al.	6,108,656 A	8/2000	Durst et al.
5,920,694 A	7/1999	Carleton et al.	6,111,580 A	8/2000	Kazama et al.
5,932,863 A	8/1999	Rathus et al.	6,111,588 A	8/2000	Newell
5,933,829 A	8/1999	Durst et al.	6,115,053 A	9/2000	Perlin
5,937,422 A	8/1999	Nelson et al.	6,115,482 A	9/2000	Sears et al.
5,946,406 A	8/1999	Frink et al.	6,115,724 A	9/2000	Booker
5,949,921 A	9/1999	Kojima et al.	6,118,888 A	9/2000	Chino et al.
5,952,599 A	9/1999	Dolby et al.	6,118,899 A	9/2000	Bloomfield et al.
5,953,541 A	9/1999	King et al.	D432,539 S	10/2000	Philyaw
5,956,423 A	9/1999	Frink et al.	6,128,003 A	10/2000	Smith et al.
5,960,383 A	9/1999	Fleischer	6,134,532 A	10/2000	Lazarus et al.
5,963,966 A	10/1999	Mitchell et al.	6,138,915 A	10/2000	Danielson et al.
5,966,126 A	10/1999	Szabo	6,140,140 A	10/2000	Hopper
5,970,455 A	10/1999	Wilcox et al.	6,144,366 A	11/2000	Numazaki et al.
5,982,853 A	11/1999	Liebermann	6,145,003 A	11/2000	Sanu et al.
5,982,928 A	11/1999	Shimada et al.	6,147,678 A	11/2000	Kumar et al.
5,982,929 A	11/1999	Ilan et al.	6,151,208 A	11/2000	Bartlett
5,983,171 A	11/1999	Yokoyama et al.	6,154,222 A	11/2000	Haratsch et al.
5,983,295 A	11/1999	Cotugno	6,154,723 A	11/2000	Cox et al.
5,986,200 A	11/1999	Curtin	6,154,737 A	11/2000	Inaba et al.
5,986,655 A	11/1999	Chiu et al.	6,154,758 A	11/2000	Chiang
5,990,878 A	11/1999	Ikeda et al.	6,157,465 A	12/2000	Suda et al.
5,990,893 A	11/1999	Numazaki	6,157,935 A	12/2000	Tran et al.
5,991,441 A	11/1999	Jourjine	6,164,534 A	12/2000	Rathus et al.
5,995,643 A	11/1999	Saito	6,167,369 A	12/2000	Schulze
5,999,664 A	12/1999	Mahoney et al.	6,169,969 B1	1/2001	Cohen
6,002,491 A	12/1999	Li et al.	6,175,772 B1	1/2001	Kamiya et al.
6,002,798 A	12/1999	Palmer et al.	6,175,922 B1	1/2001	Wang
6,002,808 A	12/1999	Freeman	6,178,261 B1	1/2001	Williams et al.
6,003,775 A	12/1999	Ackley	6,178,263 B1	1/2001	Fan et al.
6,009,420 A	12/1999	Fagg, III et al.	6,181,343 B1	1/2001	Lyons
6,011,905 A	1/2000	Huttenlocher et al.	6,181,778 B1	1/2001	Ohki et al.
6,012,071 A	1/2000	Krishna et al.	6,184,847 B1	2/2001	Fateh et al.
6,018,342 A	1/2000	Bristor	6,192,165 B1	2/2001	Irons
6,018,346 A	1/2000	Moran et al.	6,192,478 B1	2/2001	Elledge
6,021,218 A	2/2000	Capps et al.	6,195,104 B1	2/2001	Lyons
6,021,403 A	2/2000	Horvitz et al.	6,195,475 B1	2/2001	Beausoleil, Jr. et al.
6,025,844 A	2/2000	Parsons	6,199,048 B1	3/2001	Hudetz et al.
6,026,388 A	2/2000	Liddy et al.	6,201,903 B1	3/2001	Wolf et al.
6,028,271 A	2/2000	Gillespie et al.	6,204,852 B1	3/2001	Kumar et al.
6,029,141 A	2/2000	Bezos et al.	6,208,355 B1	3/2001	Schuster
6,029,195 A	2/2000	Herz	6,208,435 B1	3/2001	Zwolinski

6,212,299	B1	4/2001	Yuge	6,430,554	B1	8/2002	Rothschild
6,215,890	B1	4/2001	Matsuo et al.	6,430,567	B2	8/2002	Burridge
6,218,964	B1	4/2001	Ellis	6,433,784	B1	8/2002	Merrick et al.
6,219,057	B1	4/2001	Carey et al.	6,434,561	B1	8/2002	Durst, Jr. et al.
6,222,465	B1	4/2001	Kumar et al.	6,434,581	B1	8/2002	Forcier
6,226,631	B1	5/2001	Evans	6,438,523	B1	8/2002	Oberteuffer et al.
6,229,137	B1	5/2001	Bohn	6,448,979	B1	9/2002	Schena et al.
6,229,542	B1	5/2001	Miller	6,449,616	B1	9/2002	Walker et al.
6,233,591	B1	5/2001	Sherman et al.	6,454,626	B1	9/2002	An
6,240,207	B1	5/2001	Shinozuka et al.	6,459,823	B2	10/2002	Altunbasak et al.
6,243,683	B1	6/2001	Peters	6,460,036	B1	10/2002	Herz
6,244,873	B1	6/2001	Hill et al.	6,466,198	B1	10/2002	Feinstein
6,249,292	B1	6/2001	Christian et al.	6,466,336	B1	10/2002	Sturgeon et al.
6,249,606	B1	6/2001	Kiraly et al.	6,476,830	B1	11/2002	Farmer et al.
6,252,598	B1	6/2001	Segen	6,476,834	B1	11/2002	Doval et al.
6,256,400	B1	7/2001	Takata et al.	6,477,239	B1	11/2002	Ohki et al.
6,265,844	B1	7/2001	Wakefield	6,483,513	B1	11/2002	Haratsch et al.
6,269,187	B1	7/2001	Frink et al.	6,484,156	B1	11/2002	Gupta et al.
6,269,188	B1	7/2001	Jamali	6,486,874	B1	11/2002	Muthuswamy et al.
6,270,013	B1	8/2001	Lipman et al.	6,486,892	B1	11/2002	Stern
6,285,794	B1	9/2001	Georgiev et al.	6,489,970	B1	12/2002	Pazel
6,289,304	B1	9/2001	Grefenstette et al.	6,490,553	B2	12/2002	Van Thong et al.
6,292,274	B1	9/2001	Bohn	6,491,217	B2	12/2002	Catan
6,304,674	B1	10/2001	Cass et al.	6,493,707	B1	12/2002	Dey et al.
6,307,952	B1	10/2001	Dietz	6,498,970	B2	12/2002	Colmenarez et al.
6,307,955	B1	10/2001	Zank et al.	6,504,138	B1	1/2003	Mangerson
6,310,971	B1	10/2001	Shiyyama et al.	6,507,349	B1	1/2003	Balassanian
6,310,988	B1	10/2001	Flores et al.	6,508,706	B2	1/2003	Sitrick et al.
6,311,152	B1	10/2001	Bai et al.	6,509,707	B2	1/2003	Yamashita et al.
6,312,175	B1	11/2001	Lum	6,509,912	B1	1/2003	Moran et al.
6,313,853	B1	11/2001	Lamontagne et al.	6,510,387	B2	1/2003	Fuchs et al.
6,314,406	B1	11/2001	O'Hagan et al.	6,510,417	B1	1/2003	Woods et al.
6,314,457	B1	11/2001	Schena et al.	6,518,950	B1	2/2003	Dougherty et al.
6,316,710	B1	11/2001	Lindemann	6,520,407	B1	2/2003	Nieswand et al.
6,317,132	B1	11/2001	Perlin	6,522,333	B1	2/2003	Hatlelid et al.
6,318,087	B1	11/2001	Baumann et al.	6,525,749	B1	2/2003	Moran et al.
6,321,991	B1	11/2001	Knowles	6,526,395	B1	2/2003	Morris
6,323,846	B1	11/2001	Westerman et al.	6,526,449	B1	2/2003	Philyaw et al.
6,326,962	B1	12/2001	Szabo	6,532,007	B1	3/2003	Matsuda
6,330,976	B1	12/2001	Dymetman et al.	6,537,324	B1	3/2003	Tabata et al.
6,335,725	B1	1/2002	Koh et al.	6,538,187	B2	3/2003	Beigi
6,341,280	B1	1/2002	Glass et al.	6,539,931	B2	4/2003	Trajkovic et al.
6,341,290	B1	1/2002	Lombardo et al.	6,540,141	B1	4/2003	Dougherty et al.
6,344,906	B1	2/2002	Gatto et al.	6,542,933	B1	4/2003	Durst, Jr. et al.
6,345,104	B1	2/2002	Rhoads	6,543,052	B1	4/2003	Ogasawara
6,346,933	B1	2/2002	Lin	6,545,669	B1	4/2003	Kinawi et al.
6,347,290	B1	2/2002	Bartlett	6,546,385	B1	4/2003	Mao et al.
6,349,308	B1	2/2002	Whang et al.	6,546,405	B2	4/2003	Gupta et al.
6,351,222	B1	2/2002	Swan et al.	6,549,751	B1	4/2003	Mandri
6,356,281	B1	3/2002	Isenman	6,549,891	B1	4/2003	Rauber et al.
6,356,899	B1	3/2002	Chakrabarti et al.	6,554,433	B1	4/2003	Holler
6,360,949	B1	3/2002	Shepard et al.	6,560,281	B1	5/2003	Black et al.
6,360,951	B1	3/2002	Swinehart	6,564,144	B1	5/2003	Cherveney
6,363,160	B1	3/2002	Bradski et al.	6,570,555	B1	5/2003	Prevost et al.
RE37,654	E	4/2002	Longo	6,571,193	B1	5/2003	Unuma et al.
6,366,288	B1	4/2002	Naruki et al.	6,571,235	B1	5/2003	Marpe et al.
6,369,811	B1	4/2002	Graham et al.	6,573,883	B1	6/2003	Bartlett
6,377,296	B1	4/2002	Zlatsin et al.	6,577,329	B1	6/2003	Flickner et al.
6,377,712	B1	4/2002	Georgiev et al.	6,577,953	B1	6/2003	Swope et al.
6,377,986	B1	4/2002	Philyaw et al.	6,587,835	B1	7/2003	Treyz et al.
6,378,075	B1	4/2002	Goldstein et al.	6,593,723	B1	7/2003	Johnson
6,380,931	B1	4/2002	Gillespie et al.	6,594,616	B2	7/2003	Zhang et al.
6,381,602	B1	4/2002	Shoroff et al.	6,594,705	B1	7/2003	Philyaw
6,384,744	B1	5/2002	Philyaw et al.	6,597,443	B2	7/2003	Boman
6,384,829	B1	5/2002	Prevost et al.	6,597,812	B1	7/2003	Fallon et al.
6,393,443	B1	5/2002	Rubin et al.	6,599,130	B2	7/2003	Moehrle
6,396,523	B1	5/2002	Segal et al.	6,600,475	B2	7/2003	Gutta et al.
6,396,951	B1	5/2002	Grefenstette et al.	6,610,936	B2	8/2003	Gillespie et al.
6,400,845	B1	6/2002	Volino	6,611,598	B1	8/2003	Hayosh
6,404,438	B1	6/2002	Hatlelid et al.	6,615,136	B1	9/2003	Swope et al.
6,408,257	B1	6/2002	Harrington et al.	6,615,268	B1	9/2003	Philyaw et al.
6,409,401	B1	6/2002	Petteruti et al.	6,616,038	B1	9/2003	Olschafskie et al.
6,414,671	B1	7/2002	Gillespie et al.	6,617,369	B2	9/2003	Parfondry et al.
6,417,797	B1	7/2002	Cousins et al.	6,618,504	B1	9/2003	Yoshino et al.
6,418,433	B1	7/2002	Chakrabarti et al.	6,618,732	B1	9/2003	White et al.
6,421,453	B1	7/2002	Kanevsky et al.	6,622,165	B1	9/2003	Philyaw
6,421,675	B1	7/2002	Ryan et al.	6,624,833	B1	9/2003	Kumar et al.
6,427,032	B1	7/2002	Irons et al.	6,625,335	B1	9/2003	Kanai
6,429,899	B1	8/2002	Nio et al.	6,625,581	B1	9/2003	Perkowski

6,628,295	B2	9/2003	Wilensky	6,772,047	B2	8/2004	Butikofer
6,629,133	B1	9/2003	Philyaw et al.	6,772,338	B1	8/2004	Hull
6,630,924	B1	10/2003	Peck	6,773,177	B2	8/2004	Denoue et al.
6,631,404	B1	10/2003	Philyaw	6,775,422	B1	8/2004	Altman
6,636,763	B1	10/2003	Junker et al.	6,778,988	B2	8/2004	Bengtson
6,636,892	B1	10/2003	Philyaw	6,783,071	B2	8/2004	Levine et al.
6,636,896	B1	10/2003	Philyaw	6,785,421	B1	8/2004	Gindele et al.
6,638,314	B1	10/2003	Meyerzon et al.	6,786,793	B1	9/2004	Wang
6,638,317	B2	10/2003	Nakao et al.	6,788,809	B1	9/2004	Grzeszczuk et al.
6,640,145	B2	10/2003	Hoffberg et al.	6,788,815	B2	9/2004	Lui et al.
6,641,037	B2	11/2003	Williams	6,791,536	B2	9/2004	Keely et al.
6,643,692	B1	11/2003	Philyaw et al.	6,791,588	B1	9/2004	Philyaw
6,643,696	B2	11/2003	Davis et al.	6,792,112	B1	9/2004	Campbell et al.
6,650,761	B1	11/2003	Rodriguez et al.	6,792,452	B1	9/2004	Philyaw
6,651,053	B1	11/2003	Rothschild	6,798,429	B2	9/2004	Bradski
6,658,151	B2	12/2003	Lee et al.	6,801,637	B2	10/2004	Voronka et al.
6,661,919	B2	12/2003	Nicholson et al.	6,801,658	B2	10/2004	Morita et al.
6,664,991	B1	12/2003	Chew et al.	6,801,907	B1	10/2004	Zagami
6,669,088	B2	12/2003	Veeneman	6,804,396	B2	10/2004	Higaki et al.
6,671,684	B1	12/2003	Hull et al.	6,804,659	B1	10/2004	Graham et al.
6,677,969	B1	1/2004	Hongo	6,812,961	B1	11/2004	Parulski et al.
6,678,075	B1	1/2004	Tsai et al.	6,813,039	B1	11/2004	Silverbrook et al.
6,678,664	B1	1/2004	Ganesan	6,816,894	B1	11/2004	Philyaw et al.
6,678,687	B2	1/2004	Watanabe et al.	6,820,237	B1	11/2004	Abu-Hakima et al.
6,681,031	B2	1/2004	Cohen et al.	6,822,639	B1	11/2004	Silverbrook et al.
6,686,844	B2	2/2004	Watanabe et al.	6,823,075	B2	11/2004	Perry
6,687,612	B2	2/2004	Cherveney	6,823,388	B1	11/2004	Philyaw et al.
6,688,081	B2	2/2004	Boyd	6,824,044	B1	11/2004	Lapstun et al.
6,688,522	B1	2/2004	Philyaw et al.	6,824,057	B2	11/2004	Rathus et al.
6,688,523	B1	2/2004	Koenck	6,825,956	B2	11/2004	Silverbrook et al.
6,688,525	B1	2/2004	Nelson et al.	6,826,592	B1	11/2004	Philyaw et al.
6,690,358	B2	2/2004	Kaplan	6,827,259	B2	12/2004	Rathus et al.
6,691,107	B1	2/2004	Dockter et al.	6,827,267	B2	12/2004	Rathus et al.
6,691,123	B1	2/2004	Gulliksen et al.	6,829,650	B1	12/2004	Philyaw et al.
6,691,151	B1	2/2004	Cheyser et al.	6,830,187	B2	12/2004	Rathus et al.
6,691,194	B1	2/2004	Ofer	6,830,188	B2	12/2004	Rathus et al.
6,691,914	B2	2/2004	Isherwood et al.	6,832,116	B1	12/2004	Tillgren et al.
6,692,259	B2	2/2004	Kumar et al.	6,833,936	B1	12/2004	Seymour
6,694,356	B1	2/2004	Philyaw	6,834,804	B2	12/2004	Rathus et al.
6,697,838	B1	2/2004	Jakobson	6,836,799	B1	12/2004	Philyaw et al.
6,697,949	B1	2/2004	Philyaw et al.	6,845,913	B2	1/2005	Madding et al.
H2098	H	3/2004	Morin	6,850,252	B1	2/2005	Hoffberg
6,701,354	B1	3/2004	Philyaw et al.	6,862,046	B2	3/2005	Ko
6,701,369	B1	3/2004	Philyaw	6,868,193	B1	3/2005	Gharbia et al.
6,704,024	B2	3/2004	Robotham et al.	6,877,001	B2	4/2005	Wolf et al.
6,704,699	B2	3/2004	Nir et al.	6,879,957	B1	4/2005	Pechter et al.
6,707,581	B1	3/2004	Browning	6,880,122	B1	4/2005	Lee et al.
6,708,208	B1	3/2004	Philyaw	6,880,124	B1	4/2005	Moore
6,714,677	B1	3/2004	Stearns et al.	6,886,104	B1	4/2005	McClurg et al.
6,714,969	B1	3/2004	Klein et al.	6,892,264	B2	5/2005	Lamb
6,718,308	B1	4/2004	Nolting	6,898,592	B2	5/2005	Peltonen et al.
6,720,984	B1	4/2004	Jorgensen et al.	6,917,722	B1	7/2005	Bloomfield
6,721,921	B1	4/2004	Altman	6,917,724	B2	7/2005	Seder et al.
6,725,125	B2	4/2004	Basson et al.	6,922,725	B2	7/2005	Lamming et al.
6,725,203	B1	4/2004	Seet et al.	6,925,182	B1	8/2005	Epstein
6,725,260	B1	4/2004	Philyaw	6,931,592	B1	8/2005	Ramaley et al.
6,728,000	B1	4/2004	Lapstun et al.	6,938,024	B1	8/2005	Horvitz
6,735,632	B1	5/2004	Kiraly et al.	6,947,571	B1	9/2005	Rhoads et al.
6,738,519	B1	5/2004	Nishiwaki	6,947,930	B2	9/2005	Anick et al.
6,741,745	B2	5/2004	Dance et al.	6,952,281	B1	10/2005	Irons et al.
6,741,871	B1	5/2004	Silverbrook et al.	6,970,915	B1	11/2005	Partovi et al.
6,744,938	B1	6/2004	Rantze et al.	6,978,297	B1	12/2005	Piersol
6,745,234	B1	6/2004	Philyaw et al.	6,985,169	B1	1/2006	Deng et al.
6,745,937	B2	6/2004	Walsh et al.	6,990,548	B1	1/2006	Kaylor
6,747,632	B2	6/2004	Howard	6,991,158	B2	1/2006	Munte
6,748,306	B2	6/2004	Lipowicz	6,992,655	B2	1/2006	Ericson et al.
6,750,852	B2	6/2004	Gillespie et al.	6,993,580	B2	1/2006	Isherwood et al.
6,752,317	B2	6/2004	Dymetman et al.	7,001,681	B2	2/2006	Wood
6,752,498	B2	6/2004	Covannon et al.	7,006,881	B1	2/2006	Hoffberg
6,753,883	B2	6/2004	Schena et al.	7,010,616	B2	3/2006	Carlson et al.
6,754,632	B1	6/2004	Kalinowski et al.	7,016,084	B2	3/2006	Tsai
6,754,698	B1	6/2004	Philyaw et al.	7,016,532	B2	3/2006	Bonczyk et al.
6,757,715	B1	6/2004	Philyaw	7,020,663	B2	3/2006	Hay et al.
6,757,783	B2	6/2004	Koh	7,043,489	B1	5/2006	Kelley
6,758,398	B1	7/2004	Philyaw et al.	7,047,491	B2	5/2006	Schubert et al.
6,760,661	B2	7/2004	Klein et al.	7,051,943	B2	5/2006	Leone et al.
6,766,494	B1	7/2004	Price et al.	7,057,607	B2	6/2006	Mayoraz et al.
6,766,956	B1	7/2004	Boylan, III et al.	7,062,706	B2	6/2006	Maxwell et al.
6,771,283	B2	8/2004	Carro	7,069,240	B2	6/2006	Spero et al.

7,069,272	B2	6/2006	Snyder	7,599,844	B2	10/2009	King et al.
7,079,713	B2	7/2006	Simmons	7,606,741	B2	10/2009	King et al.
7,089,330	B1	8/2006	Mason	7,613,634	B2	11/2009	Siegel et al.
7,093,759	B2	8/2006	Walsh	7,616,840	B2	11/2009	Erol et al.
7,096,218	B2	8/2006	Schirmer et al.	7,634,407	B2	12/2009	Chelba et al.
7,103,848	B2	9/2006	Barsness et al.	7,634,468	B2	12/2009	Stephan
7,110,576	B2	9/2006	Norris, Jr. et al.	7,664,734	B2	2/2010	Lawrence et al.
7,111,787	B2	9/2006	Ehrhart	7,672,543	B2	3/2010	Hull et al.
7,117,374	B2	10/2006	Hill et al.	7,680,067	B2	3/2010	Prasad et al.
7,121,469	B2	10/2006	Dorai et al.	7,689,712	B2	3/2010	Lee et al.
7,124,093	B1	10/2006	Graham et al.	7,689,832	B2	3/2010	Talmor et al.
7,130,885	B2	10/2006	Chandra et al.	7,698,344	B2	4/2010	Sareen et al.
7,131,061	B2	10/2006	MacLean et al.	7,702,624	B2	4/2010	King et al.
7,133,862	B2	11/2006	Hubert et al.	7,706,611	B2	4/2010	King et al.
7,136,530	B2	11/2006	Lee et al.	7,707,039	B2	4/2010	King et al.
7,136,814	B1	11/2006	McConnell	7,710,598	B2	5/2010	Harrison, Jr.
7,137,077	B2	11/2006	Iwema et al.	7,742,953	B2	6/2010	King et al.
7,139,445	B2	11/2006	Pilu et al.	7,761,451	B2	7/2010	Cunningham
7,151,864	B2	12/2006	Henry et al.	7,779,002	B1	8/2010	Gomes et al.
7,165,268	B1	1/2007	Moore et al.	7,783,617	B2	8/2010	Lu et al.
7,167,586	B2	1/2007	Braun et al.	7,788,248	B2	8/2010	Forstall et al.
7,174,054	B2	2/2007	Manber et al.	7,796,116	B2	9/2010	Salsman et al.
7,174,332	B2	2/2007	Baxter et al.	7,812,860	B2	10/2010	King et al.
7,181,761	B2	2/2007	Davis et al.	7,818,215	B2	10/2010	King et al.
7,185,275	B2	2/2007	Roberts et al.	7,831,912	B2	11/2010	King et al.
7,188,307	B2	3/2007	Ohsawa	7,872,669	B2	1/2011	Darrell et al.
7,190,480	B2	3/2007	Sturgeon et al.	7,894,670	B2	2/2011	King et al.
7,197,716	B2	3/2007	Newell et al.	7,941,433	B2	5/2011	Benson
7,216,121	B2	5/2007	Bachman et al.	7,949,191	B1	5/2011	Ramkumar et al.
7,216,224	B2	5/2007	Lapstun et al.	8,082,258	B2	12/2011	Kumar et al.
7,224,480	B2	5/2007	Tanaka et al.	2001/0001854	A1	5/2001	Schena et al.
7,224,820	B2	5/2007	Inomata et al.	2001/0003176	A1	6/2001	Schena et al.
7,225,979	B2	6/2007	Silverbrook et al.	2001/0003177	A1	6/2001	Schena et al.
7,234,645	B2	6/2007	Silverbrook et al.	2001/0032252	A1	10/2001	Durst et al.
7,239,747	B2*	7/2007	Bresler et al. 382/176	2001/0034237	A1	10/2001	Garahi
7,240,843	B2	7/2007	Paul et al.	2001/0049636	A1	12/2001	Hudda et al.
7,242,492	B2	7/2007	Currans et al.	2001/0053252	A1	12/2001	Creque
7,246,118	B2	7/2007	Chastain et al.	2001/0055411	A1	12/2001	Black
7,262,798	B2	8/2007	Stavely et al.	2001/0056463	A1	12/2001	Grady et al.
7,263,521	B2	8/2007	Carpentier et al.	2002/0002504	A1	1/2002	Engel et al.
7,275,049	B2	9/2007	Clausner et al.	2002/0012065	A1	1/2002	Watanabe
7,283,992	B2	10/2007	Liu et al.	2002/0013781	A1	1/2002	Petersen
7,284,192	B2	10/2007	Kashi et al.	2002/0016750	A1	2/2002	Attia
7,289,806	B2	10/2007	Morris et al.	2002/0020750	A1	2/2002	Dymetman et al.
7,299,186	B2	11/2007	Kuzunuki et al.	2002/0022993	A1	2/2002	Miller et al.
7,299,969	B2	11/2007	Paul et al.	2002/0023158	A1	2/2002	Polizzi et al.
7,331,523	B2	2/2008	Meier et al.	2002/0023215	A1	2/2002	Wang et al.
7,339,467	B2	3/2008	Lamb	2002/0023957	A1	2/2002	Michaelis et al.
7,349,552	B2	3/2008	Levy et al.	2002/0023959	A1	2/2002	Miller et al.
7,353,199	B1	4/2008	DiStefano, III	2002/0029350	A1	3/2002	Cooper et al.
7,362,902	B1	4/2008	Baker et al.	2002/0032698	A1	3/2002	Cox
7,376,581	B2	5/2008	DeRose et al.	2002/0038456	A1	3/2002	Hansen et al.
7,383,263	B2	6/2008	Goger	2002/0049781	A1	4/2002	Bengtson
7,392,287	B2	6/2008	Ratcliff, III	2002/0051262	A1	5/2002	Nuttall et al.
7,392,475	B1	6/2008	Leban et al.	2002/0052747	A1	5/2002	Sarukkai
7,404,520	B2	7/2008	Vesuna	2002/0054059	A1	5/2002	Schneiderman
7,409,434	B2	8/2008	Lamming et al.	2002/0055906	A1	5/2002	Katz et al.
7,412,158	B2	8/2008	Kakkori	2002/0055919	A1	5/2002	Mikheev
7,415,670	B2	8/2008	Hull et al.	2002/0067308	A1	6/2002	Robertson
7,421,155	B2	9/2008	King et al.	2002/0073000	A1	6/2002	Sage
7,424,543	B2	9/2008	Rice, III	2002/0075298	A1	6/2002	Schena et al.
7,433,068	B2	10/2008	Stevens et al.	2002/0076110	A1	6/2002	Zee
7,433,893	B2	10/2008	Lowry	2002/0083054	A1	6/2002	Peltonen et al.
7,437,023	B2	10/2008	King et al.	2002/0083090	A1	6/2002	Jeffrey et al.
7,487,112	B2	2/2009	Barnes, Jr.	2002/0087598	A1	7/2002	Carro
7,493,487	B2	2/2009	Phillips et al.	2002/0090132	A1	7/2002	Boncyk et al.
7,496,638	B2	2/2009	Philyaw	2002/0091569	A1	7/2002	Kitaura et al.
7,505,785	B2	3/2009	Callaghan et al.	2002/0091928	A1	7/2002	Bouchard et al.
7,523,067	B1	4/2009	Nakajima	2002/0099812	A1	7/2002	Davis et al.
7,533,040	B2	5/2009	Perkowski	2002/0102966	A1	8/2002	Lev et al.
7,536,547	B2	5/2009	Van Den Tillaart	2002/0110248	A1	8/2002	Kovales et al.
7,552,075	B1	6/2009	Walsh	2002/0111960	A1	8/2002	Irons et al.
7,552,381	B2	6/2009	Barrus	2002/0125411	A1	9/2002	Christy
7,561,312	B1	7/2009	Proudfoot et al.	2002/0126780	A1	9/2002	Oshima et al.
7,574,407	B2	8/2009	Carro et al.	2002/0133725	A1	9/2002	Roy et al.
7,591,597	B2	9/2009	Pasqualini et al.	2002/0135815	A1	9/2002	Finn
7,593,605	B2	9/2009	King et al.	2002/0139859	A1	10/2002	Catan
7,596,269	B2	9/2009	King et al.	2002/0154817	A1	10/2002	Katsuyama et al.
7,599,580	B2	10/2009	King et al.	2002/0161658	A1	10/2002	Sussman

2002/0191847	A1	12/2002	Newman et al.	2004/0193488	A1	9/2004	Khoo et al.
2002/0194143	A1	12/2002	Banerjee et al.	2004/0199615	A1	10/2004	Philyaw
2002/0199198	A1	12/2002	Stonedahl	2004/0201633	A1	10/2004	Barsness et al.
2003/0001018	A1	1/2003	Hussey et al.	2004/0204953	A1	10/2004	Muir et al.
2003/0004724	A1	1/2003	Kahn et al.	2004/0205534	A1	10/2004	Koelle
2003/0004991	A1	1/2003	Keskar et al.	2004/0206809	A1	10/2004	Wood et al.
2003/0009459	A1	1/2003	Chastain et al.	2004/0208369	A1	10/2004	Nakayama
2003/0009495	A1	1/2003	Adjaoute	2004/0208372	A1	10/2004	Boncyk et al.
2003/0019939	A1	1/2003	Sellen	2004/0210943	A1	10/2004	Philyaw
2003/0028889	A1	2/2003	McCoskey et al.	2004/0217160	A1	11/2004	Silverbrook et al.
2003/0039411	A1	2/2003	Nada	2004/0220975	A1	11/2004	Carpentier et al.
2003/0040957	A1	2/2003	Rodriguez et al.	2004/0236791	A1	11/2004	Kinjo
2003/0043042	A1	3/2003	Moore et al.	2004/0250201	A1	12/2004	Caspi
2003/0046307	A1	3/2003	Rivette et al.	2004/0254795	A1	12/2004	Fujii et al.
2003/0050854	A1	3/2003	Showghi et al.	2004/0256454	A1	12/2004	Kocher
2003/0065770	A1	4/2003	Davis et al.	2004/0258274	A1	12/2004	Brundage et al.
2003/0083966	A1	5/2003	Treibach-Heck et al.	2004/0268237	A1	12/2004	Jones et al.
2003/0093384	A1	5/2003	Durst et al.	2005/0010750	A1	1/2005	Ward et al.
2003/0093400	A1	5/2003	Santosuosso	2005/0022114	A1	1/2005	Shanahan et al.
2003/0093545	A1	5/2003	Liu et al.	2005/0033713	A1	2/2005	Bala et al.
2003/0095689	A1	5/2003	Vollkommer et al.	2005/0063612	A1	3/2005	Manber et al.
2003/0098352	A1	5/2003	Schnee et al.	2005/0076095	A1	4/2005	Mathew et al.
2003/0106018	A1	6/2003	Silverbrook et al.	2005/0086309	A1	4/2005	Galli et al.
2003/0130904	A1	7/2003	Katz et al.	2005/0091578	A1	4/2005	Madan et al.
2003/0132298	A1	7/2003	Swartz et al.	2005/0097335	A1	5/2005	Shenoy et al.
2003/0135430	A1	7/2003	Ibbotson	2005/0108001	A1	5/2005	Aarskog
2003/0135725	A1	7/2003	Schirmer et al.	2005/0108195	A1	5/2005	Yalovsky et al.
2003/0144865	A1	7/2003	Lin et al.	2005/0132281	A1	6/2005	Pan et al.
2003/0149678	A1	8/2003	Cook	2005/0136949	A1	6/2005	Barnes
2003/0150907	A1	8/2003	Metcalfe et al.	2005/0139649	A1	6/2005	Metcalfe et al.
2003/0152293	A1	8/2003	Bresler et al.	2005/0149516	A1	7/2005	Wolf et al.
2003/0160975	A1	8/2003	Skurdal et al.	2005/0149538	A1	7/2005	Singh et al.
2003/0173405	A1	9/2003	Wilz et al.	2005/0154760	A1	7/2005	Bhakta et al.
2003/0179908	A1	9/2003	Mahoney et al.	2005/0205671	A1	9/2005	Gelsomini et al.
2003/0182399	A1	9/2003	Silber	2005/0214730	A1	9/2005	Rines
2003/0187751	A1	10/2003	Watson et al.	2005/0220359	A1	10/2005	Sun et al.
2003/0187886	A1	10/2003	Hull et al.	2005/0222801	A1	10/2005	Wulff et al.
2003/0195851	A1	10/2003	Ong	2005/0228683	A1	10/2005	Saylor et al.
2003/0200152	A1	10/2003	Divekar	2005/0231746	A1	10/2005	Parry et al.
2003/0212527	A1	11/2003	Moore et al.	2005/0251448	A1	11/2005	Gropper
2003/0214528	A1	11/2003	Pierce et al.	2005/0262058	A1	11/2005	Chandrasekar et al.
2003/0218070	A1	11/2003	Tsikos et al.	2005/0270358	A1	12/2005	Kuchen et al.
2003/0220835	A1	11/2003	Barnes	2005/0278179	A1	12/2005	Overend et al.
2003/0223637	A1	12/2003	Simske et al.	2005/0278314	A1	12/2005	Buchheit
2003/0225547	A1	12/2003	Paradies	2005/0288954	A1	12/2005	McCarthy et al.
2004/0001217	A1	1/2004	Wu	2005/0289054	A1	12/2005	Silverbrook et al.
2004/0006509	A1	1/2004	Mannik et al.	2006/0023945	A1	2/2006	King et al.
2004/0006740	A1	1/2004	Krohn et al.	2006/0036462	A1	2/2006	King et al.
2004/0015351	A1	1/2004	Gandhi et al.	2006/0041484	A1	2/2006	King et al.
2004/0015437	A1	1/2004	Choi et al.	2006/0041538	A1	2/2006	King et al.
2004/0015606	A1	1/2004	Philyaw	2006/0041590	A1	2/2006	King et al.
2004/0023200	A1	2/2004	Blume	2006/0041605	A1	2/2006	King et al.
2004/0028295	A1	2/2004	Allen et al.	2006/0045374	A1	3/2006	Kim et al.
2004/0036718	A1	2/2004	Warren et al.	2006/0048046	A1	3/2006	Joshi et al.
2004/0042667	A1	3/2004	Lee et al.	2006/0053097	A1	3/2006	King et al.
2004/0044576	A1	3/2004	Kurihara et al.	2006/0059138	A1	3/2006	Milic-Frayling et al.
2004/0044627	A1	3/2004	Russell et al.	2006/0069616	A1	3/2006	Bau
2004/0044952	A1	3/2004	Jiang et al.	2006/0075327	A1	4/2006	Sriver
2004/0052400	A1	3/2004	Inomata et al.	2006/0080314	A1	4/2006	Hubert et al.
2004/0059779	A1	3/2004	Philyaw	2006/0081714	A1	4/2006	King et al.
2004/0064453	A1	4/2004	Ruiz et al.	2006/0085477	A1	4/2006	Phillips et al.
2004/0068483	A1	4/2004	Sakurai et al.	2006/0098900	A1	5/2006	King et al.
2004/0073708	A1	4/2004	Warnock	2006/0101285	A1	5/2006	Chen et al.
2004/0073874	A1	4/2004	Poibeau et al.	2006/0103893	A1	5/2006	Azimi et al.
2004/0075686	A1	4/2004	Wattler et al.	2006/0104515	A1	5/2006	King et al.
2004/0078749	A1	4/2004	Hull et al.	2006/0119900	A1	6/2006	King et al.
2004/0098165	A1	5/2004	Butikofer	2006/0122983	A1	6/2006	King et al.
2004/0121815	A1	6/2004	Fournier et al.	2006/0126131	A1	6/2006	Tseng et al.
2004/0122811	A1	6/2004	Page	2006/0136629	A1	6/2006	King et al.
2004/0128514	A1	7/2004	Rhoads	2006/0138219	A1	6/2006	Brzezniak et al.
2004/0139106	A1	7/2004	Bachman et al.	2006/0146169	A1	7/2006	Segman
2004/0139107	A1	7/2004	Bachman et al.	2006/0173859	A1	8/2006	Kim et al.
2004/0139400	A1	7/2004	Allam et al.	2006/0195695	A1	8/2006	Keys
2004/0140361	A1	7/2004	Paul et al.	2006/0200780	A1	9/2006	Iwema et al.
2004/0158492	A1	8/2004	Lopez et al.	2006/0224895	A1	10/2006	Mayer
2004/0181688	A1	9/2004	Wittkotter	2006/0229940	A1	10/2006	Grossman
2004/0186766	A1	9/2004	Fellenstein et al.	2006/0239579	A1	10/2006	Ritter
2004/0186859	A1	9/2004	Butcher	2006/0256371	A1	11/2006	King et al.
2004/0189691	A1	9/2004	Jojic et al.	2006/0259783	A1	11/2006	Work et al.

2006/0266839	A1	11/2006	Yavid et al.	JP	2003216631	7/2003
2006/0283952	A1	12/2006	Wang	JP	2004-500635	1/2004
2007/0005570	A1	1/2007	Hurst-Hiller et al.	JP	2004-050722	2/2004
2007/0009245	A1	1/2007	Ito	KR	10-2000-0054268	9/2000
2007/0050419	A1	3/2007	Weyl et al.	KR	10-2000-0054339	9/2000
2007/0061146	A1	3/2007	Jaramillo et al.	KR	10-2000-0054268	10/2002
2007/0099636	A1	5/2007	Roth	KR	10-2004-0029895	4/2004
2007/0170248	A1	7/2007	Brundage et al.	KR	10-2007-0029895	4/2004
2007/0173266	A1	7/2007	Barnes	KR	10-2007-0051217	5/2007
2007/0194119	A1	8/2007	Vinogradov et al.	KR	10-0741368	7/2007
2007/0208561	A1	9/2007	Choi et al.	KR	10-0761912	9/2007
2007/0208732	A1	9/2007	Flowers et al.	WO	94/19766	9/1994
2007/0219940	A1	9/2007	Mueller et al.	WO	WO-9803923	1/1998
2007/0228306	A1	10/2007	Gannon et al.	WO	WO-0056055	A2 9/2000
2007/0233806	A1	10/2007	Asadi	WO	WO-00/67091	11/2000
2007/0238076	A1	10/2007	Burstein et al.	WO	WO-0103017	A1 1/2001
2007/0249406	A1	10/2007	Andreasson	WO	01/24051	4/2001
2007/0279711	A1	12/2007	King et al.	WO	01/33553	5/2001
2007/0300142	A1	12/2007	King et al.	WO	01/33553	A2 5/2001
2008/0023550	A1	1/2008	Yu et al.	WO	WO-02/11446	A2 2/2002
2008/0046417	A1	2/2008	Jeffery et al.	WO	WO-02061730	A1 8/2002
2008/0071775	A1	3/2008	Gross	WO	WO-02/091233	A2 11/2002
2008/0072134	A1	3/2008	Balakrishnan et al.	WO	WO-2004/084109	9/2004
2008/0082903	A1	4/2008	McCurdy et al.	WO	WO-2005/071665	A1 8/2005
2008/0091954	A1	4/2008	Morris et al.	WO	2005/096750	10/2005
2008/0126415	A1	5/2008	Chaudhury et al.	WO	2005/096755	10/2005
2008/0137971	A1	6/2008	King et al.	WO	2005/098596	10/2005
2008/0141117	A1	6/2008	King et al.	WO	2005/098597	10/2005
2008/0170674	A1	7/2008	Ozden et al.	WO	2005/098598	10/2005
2008/0172365	A1	7/2008	Ozden et al.	WO	2005/098599	10/2005
2008/0177825	A1	7/2008	Dubinko et al.	WO	2005/098600	10/2005
2008/0195664	A1	8/2008	Maharajh et al.	WO	2005/098601	10/2005
2008/0222166	A1	9/2008	Hultgren et al.	WO	2005/098602	10/2005
2008/0235093	A1	9/2008	Uland	WO	2005/098603	10/2005
2008/0313172	A1	12/2008	King et al.	WO	2005/098604	10/2005
2009/0012806	A1	1/2009	Ricordi et al.	WO	2005/098605	10/2005
2009/0018990	A1	1/2009	Moraleda	WO	2005/098605	A2 10/2005
2009/0077658	A1	3/2009	King et al.	WO	2005/098606	10/2005
2009/0247219	A1	10/2009	Lin et al.	WO	2005/098607	10/2005
2010/0092095	A1	4/2010	King et al.	WO	2005/098609	10/2005
2010/0121848	A1	5/2010	Yaroslavskiy et al.	WO	2005/098610	10/2005
2010/0182631	A1	7/2010	King et al.	WO	2005/101192	10/2005
2010/0183246	A1	7/2010	King et al.	WO	2005/101193	10/2005
2010/0185538	A1	7/2010	King et al.	WO	2005/106643	11/2005
2010/0185620	A1	7/2010	Schiller	WO	2005/114380	12/2005
2010/0278453	A1	11/2010	King et al.	WO	2006/014727	2/2006
2010/0318797	A1	12/2010	King et al.	WO	2006/023715	3/2006
2011/0019020	A1	1/2011	King et al.	WO	2006/023717	3/2006
2011/0019919	A1	1/2011	King et al.	WO	2006/023718	3/2006
2011/0022940	A1	1/2011	King et al.	WO	2006/023806	3/2006
2011/0025842	A1	2/2011	King et al.	WO	2006/023937	3/2006
2011/0026838	A1	2/2011	King et al.	WO	2006/026188	3/2006
2011/0029443	A1	2/2011	King et al.	WO	WO-2006029259	A2 3/2006
2011/0029504	A1	2/2011	King et al.	WO	2006/036853	4/2006
2011/0033080	A1	2/2011	King et al.	WO	2006/037011	4/2006
2011/0035289	A1	2/2011	King et al.	WO	2006/093971	9/2006
2011/0035656	A1	2/2011	King et al.	WO	2006/124496	11/2006
2011/0035662	A1	2/2011	King et al.	WO	2007/141020	12/2007
2011/0043652	A1	2/2011	King et al.	WO	2008/014255	1/2008
2011/0044547	A1	2/2011	King et al.	WO	WO-2008/002074	A1 1/2008
2011/0072012	A1	3/2011	Ah-Pine et al.	WO	2008/028674	3/2008
2011/0209191	A1	8/2011	Shah	WO	2008/031625	3/2008
2011/0295842	A1	12/2011	King et al.	WO	2008/072874	6/2008
2011/0299125	A1	12/2011	King et al.	WO	2010/096191	8/2010
				WO	2010/096192	8/2010
				WO	2010/096193	8/2010
				WO	2010/105244	9/2010
				WO	2010/105245	9/2010
				WO	2010/105246	9/2010
				WO	2010/108159	9/2010

FOREIGN PATENT DOCUMENTS

EP	0596247	5/1994
EP	0697793	A2 2/1996
EP	0887753	A1 12/1998
EP	1054335	A2 11/2000
EP	1087305	A2 3/2001
EP	1141882	10/2001
EP	1318659	A1 6/2003
EP	1398711	3/2004
GB	2 366 033	A 2/2002
JP	3260768	11/1991
JP	10-133847	5/1998
JP	H11-213011	8/1999
JP	2001-345710	12/2001

OTHER PUBLICATIONS

“Automatic Computer Translation,” www.lingolex.com/translationsoftware.htm, downloaded on Aug. 6, 2000.
 Agilent Technologies. “Agilent ADNK-2133 Optical Mouse Designer’s Kit: Product Overview.” 2004, 6 pp.
 Airclac. “Products.” <http://www.airclac.com/products.asp>, accessed Oct. 3, 2005, 3pp.

- Arai, Toshifumi, Dietmar Aust, Scott E. Hudson. "Paperlink: A Technique for Hyperlinking From Real Paper to Electronic Content." Proceedings of the ACM Conference on Human Factors in Computing Systems (CHI 97) Addison-Wesley, Apr. 1997, pp. 327-334.
- Aust, Dietmar. "Augmenting Paper Documents with Digital Information in a Mobile Environment" MS Thesis, University of Dortmund, Department of Computer Graphics, 1996. 47pp.
- Babylon—Online Dictionary and Translation Software, "Text Translations in 75 languages, all in a single click," 1997, 1 page.
- Bai, Zhen-Long, and Qiang Huo "An Approach to Extracting the Target Text Line from a Document Image Captured by a Pen Scanner." Proceedings of the Seventh International Conference on Document Analysis and Recognition (ICDAR 2003), 2003, 5 pp.
- Baumer, Stefan (Ed.) Handbook of Plastic Optics. Weinheim, Germany: Wiley-VCH Verlag GmbH & Co. KGaA. 2005, 199pp.
- Bell, Timothy, Ian H. Witten, John G. Cleary. "Modeling for Text Compression." ACM Computing Surveys, vol. 21, No. 4, Dec. 1989, pp. 557-591.
- Bentley, Jon L. and Robert Sedgwick. "Fast Algorithms for Sorting and Searching Strings." Proceedings of the 10th ACM-SIAM Symposium on Discrete Algorithms. New York, NY: ACM Press, 1997, pp. 360-369.
- Black et al., "The Festival Speech Synthesis System," Festival Speech Synthesis System-Table of Contents, <http://www.cstr.ed.ac.uk/projects/festival/manual/>, Jun. 17, 1999, pp. 1-4 [internet accessed on Jan. 10, 2008].
- C Technologies AB. "CPEN User's Guide." Jan. 2001, 130pp.
- C Technologies AB. "User's Guide for C-Pen 10." Aug. 2001, 128pp.
- Capobianco, Robert A. "Design Considerations for: Optical Coupling of Flashlamps and Fiber Optics." PerkinElmer, 1998-2003. <http://optoelectronics.perkinelmer.com/content/whitepapers/OpticalCoupling.pdf>, 12 pp.
- Casio Computer Co. Ltd, ALPS Electric Co., Ltd. "Alliance Agreement on Development and Mass Production of Fingerprint Scanner for Mobile Devices." Press Release, Feb. 25, 2003. <http://world.casio.com/pacific/news/2003/fingerprint.html>, 2pp.
- Final Office Action for U.S. Appl. No. 11/097,835, Mail Date Jun. 23, 2008, 26 pages.
- Final Office Action for U.S. Appl. No. 11/098,043, Mail Date Apr. 17, 2008, 45 pages.
- Final Office Action for U.S. Appl. No. 11/098,043, Mail Dater Apr. 17, 2008, 45 pages.
- Fitzgibbon, Andrew, and Ehud Reiter. "Memories for Life: Managing Information Over a Human Lifetime," UK Computing Research Committee's Grand Challenges in Computing Workshop, May 22, 2003. 8pp.
- Ghani, Rayid, Rosie Jones, and Dunja Mladenić. "Mining the Web to Create Minority Language Corpora." Proceedings of the 10th International Conference on Information and Knowledge Management (CIKM). Atlanta, Georgia, Nov. 5-10, 2001, pp. 279-286.
- Gildea and Miller, "How Children Learn Words," Scientific American, Sep. 1987, vol. 257, No. 3, pp. 94-99.
- Globalink, Inc. globalink, Inc. announces Talk to Me, an interactive language learning software program, "Talk to me" Software, Business Wire, Jan. 21, 1997, Fairfax, VA, 4 pages. [internet accessed on Jan. 4, 2008].
- Google. "Google Search Appliance—Intranets." http://www.google.com/appliance/pdf/ds_GSA_intranets.pdf, 2004, 2 pp.
- Google. "Simplicity and Enterprise Search." 2003 http://www.google.com/enterprise/pdf/google_simplicity_enterprise_wp.pdf, 7pp.
- Graham, Jamey, Berna Erol, Jonathan J. Hull, and Dar-Shyang Lee. "The Video Paper Multimedia Playback System." Proceedings of the Eleventh ACM International Conference on Multimedia. New York, NY: ACM Press, 2003, pp. 94-95.
- Grossman, David A, Ophir Frieder, Nazli Goharian "Token Identification" Slideshow. 2002, 15 pp.
- Guimbretière, François. "Paper Augmented Digital Documents." Proceedings of Annual ACM Symposium on User Interface Software and Technology. New York, NY: ACM Press, 2003, 10pp.
- Hansen, Jesse. "A Matlab Project in Optical Character Recognition (OCR)." DSP Lab, University of Rhode Island. May 15 2002, 6pp.
- Heiner, Jeremy M., Scott E. Hudson, Kenichiro Tanaka. "Linking and Messaging from Real Paper in the Paper PDA." ACM Symposium on User Interface Software and Technology. New York, NY: ACM Press, 1999, pp. 179-186.
- Henseler, Dr. Hans, "Functional and Document Level Security in ZyIMAGE," Zylab, the Paper Filing Company, m ZyIMAGE Security, Whitepaper, Apr. 9, 2004, 27 pgs. ZyLAB Technologies, B.V. Hewlett-Packard Company. "HP Capshare 920 Portable E-Copier and Information Appliance User Guide, First Edition." 1999, 42 pp.
- Hjaltason, Gisli R. and Hanan Samet. "Distance Browsing in Spatial Databases." ACM Transactions on Database Systems. vol. 24, No. 2, Jun. 1999: 265-318.
- Kahan, José and Marja-Riitta Koivunen. "Annotea: An Open RDF Infrastructure for Shared Web Annotations." Proceedings of the 10th International World Wide Web Conference, Hong Kong, 2001. <http://www10.org/cdrom/papers/frame.html>, pp. 623-632.
- Kasabach, Chris, Chris Pacione, John Stivoric, Francine Gemperle, Dan Siewiorek. "Digital Ink: A Familiar Idea with Technological Might!" CHI 1998 Conference. New York, NY: ACM Press, 1998, pp. 175-176.
- Keytronic. "F-Scan-S001US Stand Alone Fingerprint Scanner." <http://www.keytronic.com/home/shop/Productlist.asp?CATID=62&SubCATID=1>, accessed Oct. 4, 2005, 2pp.
- Khoubyari, Siamak. "The Application of Word Image Matching in Text Recognition." MS Thesis, State University of New York at Buffalo, Jun. 1992, 107pp.
- Kia, Omid and David Doerman. "Integrated Segmentation and Clustering for Enhanced Compression of Document Images." International Conference on Document Analysis and Recognition, Ulm Germany Aug. 18-20, 1997 vol. 1. 6 pp.
- Kia, Omid E. "Document Image Compression and Analysis." PhD Thesis, University of Maryland at College Park, 1997, 141pp.
- Kia, Omid, David Doerman, Azriel Rosenfeld, Rama Chellappa. "Symbolic Compression and Processing of Document Images." Technical Report: LAMP-TR-004/CFAR-TR-849/CS-TR-3734, University of Maryland, College Park, Jan. 1997, 36pp.
- Kia, Omid. "Integrated Segmentation and Clustering for Enhanced Compression of Document Images." International Conference on Document Analysis and Recognition, Ulm, Germany, Aug. 18-20, 1997, 7pp.
- Kopec, Gary E. "Multilevel Character Templates for Document Image Decoding." IS&T/SPIE 1997 International Symposium on Electronic Imaging: Science & Technology, San Jose, CA. Feb. 8-14, 1997, 10pp.
- Kopec, Gary E., Maya R. Said, Kris Popat. "N-Gram Language Models for Document Image Decoding." Proceedings of IS&T/SPIE Electronics Imaging 2002: Document Recognition and Retrieval IX, vol. 4670-20, Jan. 2002. 12pp.
- Kukich, Karen. "Techniques for Automatically Correcting Words in Text." ACM Computing Surveys, vol. 24, No. 4, Dec. 1992: pp. 377-439.
- Lee, Bongsoo, Won Y. Choi, James K. Walker. "Ultrahigh-Resolution Plastic Graded-index fused Image Plates." Optics Letters, vol. 24, No. 10, May 15, 2000: 719-721.
- Lee, D.L. and F.H. Lochofsky. "Voice Response Systems." ACM Computing Surveys, vol. 15, Issue 4, Dec. 1983: pp. 351-374.
- Lee, Dar-Shyang and Jonathan J. Hull. "Detecting Duplicates Among Symbolically Compressed Images in a Large Document Database." Pattern Recognition Letters, No. 22, 2001: 545-550.
- Lee, Dar-Shyang and Jonathan J. Hull. "Duplicate Detection for Symbolically Compressed Documents." Fifth International Conference on Document Analysis and Recognition (ICDAR), 1999, 4pp.
- Lee, Dar-Shyang. "Substitution Deciphering Based on HMMs with Applications to Compressed Document Processing." IEEE Transactions on Pattern Analysis and Machine Intelligence, vol. 24, No. 12., Washington DC: IEEE Computer Society, Dec. 2002, pp. 1661-1666.
- Leshner, G.W., Moulton, B.J. & Higginbotham, D.J. (1999) "Effects of Ngram Order and Training Text Size on Word Prediction." Proceedings of the RESNA '99 Annual Conference, 1999, 3pp.
- Lieberman, Henry. "Out of Many, One: Reliable Results from Unreliable Recognition." ACM Conference on Human Factors in Computing Systems (CHI 2002); Apr. 20-25, 2000; Minneapolis, MN; 2 pp.

- Liu, Lon-Mu, Yair M. Babad, Wei Sun, and Ki-Kan Chan. "Adaptive Post-Processing of OCR Text Via Knowledge Acquisition." Proceedings of the ACM 1991 Computer Science Conference. New York, NY: ACM Press, 1991, pp. 558-569.
- Ljungstrand, Peter, Johan Redström, and Lars Erik Holmquist. "Webstickers: Using Physical Tokens to Access, Manage, and Share Bookmarks to the Web." Proceedings of Designing Augmented Reality Environments 2000, Elsinore, Denmark, Apr. 12-14, 2000, pp. 23-31.
- LTI Computer Vision Library "LTI Image Processing Library Developer's Guide. Version 29.10.2003." Aachen, German, 2002, 45 pp.
- Macholl, R., "Translation Pen Lacks Practicality," BYTE.com, Jan. 1998, 2 pages.
- Manolescu, Dragos-Anton. "Feature Extraction—A Pattern for Information Retrieval" Proceedings of the 5th Pattern Languages of Programming, Monticello, Illinois, Aug. 1998, 18pp.
- McNamee, Paul, James Mayfield, Christine Piatko. "Haircut: A System for Multilingual Text Retrieval in Java." Journal of Computing Sciences in Small Colleges. vol. 17, Issue 2, Feb. 2002: 8-22.
- Mind Like Water. "Collection Creator." www.collectioncreator.com, accessed Oct. 2, 2005, 3pp.
- Muddu, Prashant. "A Study of Image Transmission Through a Fiber-Optic Conduit and its Enhancement Using Digital Image Processing Techniques." Thesis, Florida State College of Engineering, Nov. 18, 2003, 93 pp.
- Munich, Mario E, and Pietro Perona. "Visual Input for Pen-Based Computers." Proceedings of the International Conference on Pattern Recognition (ICPR '96) vol. III. Los Alamitos, CA: IEEE CC Press. Jun. 1996, 5pp.
- Murdoch, Gregory and Nicholas Kushmerick. "Mapping Physical Artifacts to their Web Counterparts: A Case Study with Products Catalogs." MHCI-2004 Workshop on Mobile and Ubiquitous Information Access (Strathclyde, UK). 2004, 7pp.
- Nabeshima, Shinji, Shinichirou Yamamoto, Kiyoshi Agusa, Toshio Taguchi. "Memo-Pen: A New Input Device." CHI '95 Proceedings Short Papers. New York, NY: ACM Press, 1995, pp. 256-257.
- Nagy et al. "A Prototype Document Image Analysis System for Technical Journals," Computer, vol. 25, issue 7, Jul. 1992, pp. 10-22.
- Neomedia Technologies "Paperclick for Cellphones." Brochure. 2004, 2pp.
- Neomedia Technologies "Paperclick Linking Services." Brochure. 2004, 1 page.
- Neomedia Technologies. "For Wireless Communication Providers." Brochure. 2004, 1 page.
- Neville, Sean. "Project Atom, Amazon, Mobile Web Services, and Fireflies at REST" Artima Weblogs, <http://www.artima.com/weblogs/viewpost.jsp?thread=18731>, Oct. 24, 2003, 4pp.
- Newman, et al. "Camworks: A video-based tool for efficient capture from paper source documents", IEEE, pp. 647-653, 1999.
- Nautilus Hyosung. "New Software for Automated Teller Machines." http://www.nautilus.hyosung.com/product_service/software_software05.html, accessed Oct. 4, 2005, 3pp.
- Newman, William and Pierre Wellner. "A Desk Supporting Computer-based Interaction with Paper Documents." Proceedings of ACM CHI'92 Conference on Human Factors in Computing Systems. New York, NY: ACM Press, 1992, pp. 587-592.
- Non-Final Office Action for U.S. Appl. No. 11/098,038, mail date Aug. 28, 2006.
- Non-Final Office Action for U.S. Appl. No. 11/208,458, mail date Mar. 21, 2007.
- Non-Final Office Action for U.S. Appl. No. 11/098,016, mail date Apr. 24, 2007.
- Non-Final Office Action for U.S. Appl. No. 11/098,038, mail date Jun. 2007.
- Non-Final Office Action for U.S. Appl. No. 11/097,103, mail date Jun. 25, 2007.
- Non-Final Office Action for U.S. Appl. No. 11/097,093, mail date Jul. 10, 2007.
- Non-Final Office Action for U.S. Appl. No. 11/098,043, mail date Jul. 23, 2007.
- Non-Final Office Action for U.S. Appl. No. 11/110,353, mail date Jul. 27, 2007.
- Non-Final Office Action for U.S. Appl. No. 11/208,457, mail date Oct. 9, 2007.
- Non-Final Office Action for U.S. Appl. No. 11/097,835, mail date Oct. 9, 2007.
- Non-Final Office Action for U.S. Appl. No. 11/004,637, mail date Dec. 21, 2007.
- Non-Final Office Action for U.S. Appl. No. 11/097,103, mail date Jan. 28, 2008.
- Non-Final Office Action for U.S. Appl. No. 11/098,038, mail date Apr. 3, 2008.
- Non-Final Office Action for U.S. Appl. No. 11/110,353, mail date Jun. 11, 2008.
- Non-Final Office Action for U.S. Appl. No. 11/098,014, Mail Date Jun. 18, 2008, 37 pages.
- Non-Final Office Action for U.S. Appl. No. 11/097,828, Mail Date May 22, 2008, 38 pages.
- Non-Final Office Action for U.S. Appl. No. 11/097,833, Mail Date Jun. 25, 2008, 58 pages.
- Non-Final Office Action for U.S. Appl. No. 11/097,836, Mail Date May 13, 2008, 56 pages.
- Non-Final Office Action for U.S. Appl. No. 11/098,038, Mail Date Apr. 3, 2008, 11 pages.
- Non-Final Office Action for U.S. Appl. No. 11/098,043, mail date Apr. 17, 2008.
- Non-Final Office Action for U.S. Appl. No. 11/097,836, mail date May 13, 2008.
- Non-Final Office Action for U.S. Appl. No. 11/097,828, mail date May 22, 2008.
- Non-Final Office Action for U.S. Appl. No. 11/098,014, mail date Jun. 18, 2008.
- Final Office Action for U.S. Patent App. 11/097,835, mail date Jun. 23, 2008.
- Non-Final Office Action for U.S. Appl. No. 11/097,833, mail date Jun. 25, 2008.
- Non-Final Office Action for U.S. Appl. No. 11/097,089, mail date Aug. 13, 2008.
- Non-Final Office Action for U.S. Appl. No. 11/097,961, mail date Sep. 15, 2008.
- Non-Final Office Action for U.S. Appl. No. 11/004,637, mail date Oct. 2, 2008.
- Non-Final Office Action for U.S. Appl. No. 11/208,408, mail date Oct. 7, 2008.
- Non-Final Office Action for U.S. Appl. No. 11/098,042, mail date Dec. 5, 2008.
- Non-Final Office Action for U.S. Appl. No. 11/098,043, mail date Dec. 23, 2008.
- Non-Final Office Action for U.S. Appl. No. 11/097,103, mail date Dec. 31, 2008.
- Final Office Action for U.S. Appl. No. 11/097,836, mail date Jan. 6, 2009.
- Final Office Action for U.S. Appl. No. 11/110,353, mail date Jan. 6, 2009.
- Non-Final Office Action for U.S. Appl. No. 11/131,945, mail date Jan. 8, 2009.
- Non-Final Office Action for U.S. Appl. No. 11/097,981, mail date Jan. 16, 2009.
- Final Office Action for U.S. Appl. No. 11/098,014, Mail Date Jan. 23, 2009.
- Non-Final Office Action for U.S. Appl. No. 11/236,440, mail date Jan. 22, 2009.
- Final Office Action for U.S. Appl. No. 11/097,828, mail date Feb. 4, 2006.
- Non-Final Office Action for U.S. Appl. No. 11/097,835, mail date Feb. 19, 2009.
- Notice of Allowance for U.S. Appl. No. 11/098,038, mail date Mar. 11, 2009.
- Notice of Allowance for U.S. Appl. No. 11/098,042, mail date Apr. 13, 2009.
- Final Office Action for U.S. Appl. No. 11/208,408, mail date May 11, 2009.
- O'Gorman, "Image and Document Processing Techniques for the Right Pages Electronic Library System," 11th International Confer-

- ence on Pattern Recognition, Aug. 30-Sep. 3, 1992, The Hague, The Netherlands, pp. 260-263, IEEE Computer Society Press, Los Alamitos, CA.
- Pal, U. S. Sinha, and B.B. Chaudhuri. "Multi-Oriented Text Lines Detection and Their Skew Estimation." Indian Conference on Computer Vision, Graphics, and Image Processing, Ahmedabad, India, Dec. 16-18, 2002, 6pp.
- PCT International Search Report for International Application No. PCT/US05/11017, date of mailing Jul. 15, 2008, 2 pages.
- PCT International Search Report for International Application No. PCT/US05/11089, date of mailing Jul. 8, 2008, 3 pages.
- Peacocks MD&B. "Peacocks MD&B, Releases Latest hands and Eyes Free Voice Recognition Barcode Scanner." <http://www.peacocks.com.au/store/page.pl?id=457>, Dec. 5, 2004, 2pp.
- Pellissippi Library, NetLibrary, Skills Guide #4, Sep. 21, 2001, 9 pages.
- Peterson, James L. "Detecting and Correcting Spelling Errors." Communications of the ACM, vol. 23 No. 12, Dec. 1980, pp. 676-687.
- Planon Systems Solutions. "Docupen 700." <http://www.docupen.com>, accessed Oct. 3, 2005.
- Podio, Fernando L. "Biometrics—Technologies for Highly Secure Personal Authentication," National Institute of Standards and Technology, <http://whitepapers.zdnet.com/search.aspx?compid=3968>, May 2001, 8pp.
- Precise Biometrics. "Precise 200 MC." <http://www.precisebiometrics.com/data/content/DOCUMENTS/200592691619553200%20MC.pdf>, accessed Oct. 4, 2005, 2pp.
- Press Release, "Abera Introduces Truly Portable & Wireless Color Scanners: Capture Images Anywhere in the World without Connection to PC," PR Newswire, Oct. 9, 2000, New York, <http://proquest.umi.com/pqdweb?did=62278377&sid=5&Fmt=7&clientid=19649&RQT=309&VName=PQD>, 3 pages.
- Price, Morgan N., Gene Golovchinsky, Bill N. Schilit. "Linking by Inking: Trailblazing in a Paper-like Hypertext." Proceedings of Hypertext '98. Pittsburgh, PA: ACM Press, 1998, 10 pp.
- Psion Teklogix. "WORKABOUT PRO." <http://www.psionteklogix.com/public.aspx?s=uk&p=Products&pCat=128&pID=1058>, accessed Oct. 3, 2005, 2pp.
- Rao, Ramana, Stuart K. Card, Walter Johnson, Leigh Klotz, and Randall H. Trigg. "Protofoil: Storing and Finding the Information Worker's Paper Documents in an Electronic File Cabinet." Proceedings of the ACM SIGCHI Conference on Human Factors in Computing Systems. New York, NY: ACM Press, 1994, pp. 180-185, 477.
- Roberts, David A. and Richard R.A. Syms. "1D and 2D Laser Line Scan Generation Using a Fibre Optic Resonant Scanner." Department of Electronic and Electrical Engineering, Imperial College of Science Technology and Medicine, 2003, 11 pp.
- Rus, Daniela, and Devika Subramanian. "Multi-media RISSC Informatics: Retrieving Information with Simple Structural Components." Proceedings of the Second International Conference on Information and Knowledge Management. New York, NY: 1993, pp. 283-294.
- Samet, Hanan. "Data Structures for Quadtree Approximation and Compression." Communications of the ACM, vol. 28, No. 9, Sep. 1985: pp. 973-993.
- Sanderson, Mark and C.J. Van Rijsbergen. "The Impact on Retrieval Effectiveness of Skewed Frequency Distributions." ACM Transactions on Information Systems, vol. 17, No. 4, Oct. 1999: pp. 440-465.
- Sarre, et al., HyperTeX—a system from the automatic generation of hypertext textbooks from linear texts, Database and Expert System Applications. Proceedings of the International Conference, 1990, Austria, p. 62-8.
- Schilit, Bill N., Gene Golovchinsky, Morgan N. Price. "Beyond Paper: Supporting Active Reading with Free Form Digital Ink Annotations." Proceedings of CHI 98. New York, NY: ACM Press, 1998, 8pp.
- Schott North America, "Clad Rod/ Image Conduit" Nov. 2004, 1 page.
- Schuuring, D., "Best practices in e-discovery and e-disclosure." ZyLAB Information Access Solutions, White Paper, Feb. 17, 2006, 72 pgs, ZyLAB Distributing, B.V.
- Selberg, Erik, and Oren Etzioni. "On the Instability of Web Search Engines." In the Proceedings of RIAO, Paris, Apr. 2000, 14pp.
- Sheridon et al., "The Gyricon—A Twisting Ball Display," Proceedings of the Society for Information Display, Third and Fourth Quarter, May 1977, pp. 289-293, Boston, MA.
- Smithwick, Quinn Y. J., Juris Vagners, Per G. Reinhall, Eric J. Seibel. "54.3: Modeling and Control of the Resonant Fiber Scanner for Laser Scanning Display or Acquisition." SID Symposium Digest of Technical Papers, vol. 34, Issue 1, May 2003: 1455-1457.
- Sonka, Milan, Vaclav Hlavac, and Roger Boyle, Image Processing, Analysis, and Machine Vision: (Second Edition). International Thomson Publishing, 1998. Contents, Index, Preface, 37pp.
- Sony. "Sony Puppy Fingerprint Identity Products." <http://bssc.sel.sony.com/Professional/puppy/>, 2002, 1 p.
- Spitz, A. Lawrence. "Progress in Document Reconstruction." Document Recognition Technologies, Inc. 16th International Conference on Pattern Recognition (ICPR '02), 2002, 4pp.
- Spitz, A. Lawrence. "Shape-based Word Recognition." International Journal on Document Analysis and Recognition, Oct. 20, 1998, 13 pp.
- Srihari, Sargur N., Jonathan J. Hull, and Ramesh Choudhari. "Integrating Diverse Knowledge Sources in Text Recognition." ACM Transactions in Office Information Systems. vol. 1, No. 1, Jan. 1983, pp. 68-87.
- Stevens, Jacob, Andrew Gee, and Chris Dance. "Automatic Processing of Document Annotations." Xerox Research Centre Europe. <http://www.bmva.ac.uk/bmvc/1998/pdf/p062.pdf>, 1998, 11 pp.
- Stifelman, Lisa J., "Augmenting Real-World Objects: A Paper-Based Audio Notebook" Proceedings of CHI '96, 1996, pp. 199-200.
- Story et al. "The Right Pages Image-Based Electronic Library for Alerting and Browsing," Computer, vol. 25, No. 9, Sep. 1992, pp. 17-26.
- Su, Guo-Dung J., Shi-Sheng Lee, and Ming C. Wu. "Optical Scanners Realized by Surface-Micromachined Vertical Torsion Mirror" IEEE Photonics Technology Letters, vol. 11, No. 5, May 1999, 3pp.
- Syscan Imaging. "Travelscan 464." http://www.syscaninc.com/prod_464.html, accessed Oct. 3, 2005, 2pp.
- Taghva, Kazem, Julie Borsack, and Allen Condit. "Results of Applying Probabilistic IR to OCR Text." Proceedings of the 17th Annual International ACM-SIGIR Conference on Research and Development in Information Retrieval. New York, NY: Springer-Verlag New York, 1994, pp. 202-211.
- Tan, Chew Lim, Sam Yuan Sung, Zhaohui Yum and Yi Xu. "Text Retrieval from Document Images Based on N-Gram Algorithm." PRICAI Workshop on Text and Web Mining, 2000. 2 pp.
- The Festival Speech Synthesis System, www.cstr.ed.ac.uk/projects/festival downloaded on Jul. 25, 2000, 2 pages [internet accessed Jan. 4, 2008].
- Toshifumi et al., "PaperLink: A Technique for Hyperlinking from Real Paper to Electronic Content," Proceedings of CHI 1997, pp. 1-13, CHI 97 Electronic Publications: Papers.
- Trusted Reviews. "Digital Pen Roundup." <http://www.trustedreviews.com/article.aspx?art=183>, Jan. 24, 2004. 5pp.
- TYI Systems Ltd. "Bellus iPen." http://www.bellus.com.tw/pen_scanner.htm, accessed Oct. 3, 2005, 3pp.
- U.S. Precision Lens, Inc. The Handbook of Plastic Optics a User's Guide with Emphasis on Injection Molded Optics. Cincinnati, Ohio: U.S. Precision Lens, Inc., 1983, 145pp.
- Van Eijkelenborg, Martijn A. "Imaging with Microstructured Polymer Fibre." Optics Express, vol. 12, No. 2, Jan. 26, 2004, pp. 342-346.
- Vervoort, Marco. "Emile 4.1.6 User Guide" University of Amsterdam, Jun. 12, 2003, 83 pp.
- Vocollect. "Vocollect Voice for Handhelds." http://www.vocollect.com/offers/voice_handhelds.php, accessed Oct. 3, 2005, 2pp.
- Vossler, Charles M. and Neil M. Branston. "The Use of Context for Correcting Garbled English Text." Cornell Aeronautical Laboratory, Inc.. Proceedings of the 1964 19th ACM National Conference. NY, NY: ACM Press, 13 pp.
- Wang, Jin, and Jack Jean. "Segmentation of Merged Characters by Neural Network and Shortest-Path." Proceedings of the 1993 ACM/SIGAPP Symposium on Applied Computing: States of the Art and Practice. New York, NY: ACM Press, 1993, pp. 762-769.

- Wang, Wei-Chih, Mark Fauver, Jou Nhut Ho, Eric J. Siebel, Per G. Reinhall. "Micromachined Optical Waveguide Cantilever as a Resonant Optical Scanner." *Sensors and Actuators A (Physical)*, 102(1-2), 2002, pp. 165-175.
- Wang, Yalin, Ihsin T. Phillips, and Robert M. Haralick. "A Study on the Document Zone Content Classification Problem." *Proceedings of the 5th International Workshop on Document Analysis Systems*. London: Springer-Verlag, 2002, 12pp.
- Whittaker et al., "Filochat: Handwritten Notes Provide Access to Recorded Conversations," *Human Factors in Computing Systems, CHI '94 Conference Proceedings*, Apr. 24-28, 1994, pp. 271-277, Boston Massachusetts.
- Whittaker et al., "Using Cognitive Artifacts in the Design of Multimodal Interfaces," *AT&T Labs-Research*, May 24, 2004, 63 pages.
- Wilcox et al., "Dynamite: A Dynamically Organized Ink and Audio Notebook," *Conference on Human Factors in Computing Systems*, Jun. 3, 1998, 9 pages.
- WizCom Technologies Ltd. "QuickLink-Pen Elite." http://www.wizcomtech.com/Wizcom/products/product_info.asp?fid=101, Accessed Oct. 3, 2005, 2pp.
- WizCom Technologies. "SuperPen Professional Product Page." http://www.wizcomtech.com/Wizcom/products/product_info.asp?fid=88&cp=1, accessed Oct. 3, 2005, 2pp.
- Xerox "Patented Technology Could Turn Camera Phone Into Portable Scanner." Press release Nov. 15, 2004. http://www.xerox.com/go/xrx/template/inv_rel_newsroom.jsp?Xcntry=USA&Xlang=en_US&a_pp=Newsroom&ed_name=NR_2004Nov15_MobileDocument_Imaging_Software&format=article&view=newsrelease&metrics=notrack, 2pp.
- European Search Report for EP Application No. 05731509 dated Apr. 23, 2009.
- European Search Report for EP Application No. 05732913 dated Feb. 28, 2011.
- European Search Report for EP Application No. 05733191 dated Apr. 23, 2009.
- European Search Report for EP Application No. 05733819 dated Mar. 31, 2009.
- European Search Report for EP Application No. 05733851 dated Sep. 2, 2009.
- European Search Report for EP Application No. 05733915 dated Jan. 12, 2010.
- European Search Report for EP Application No. 05734996 dated Mar. 23, 2009.
- European Search Report for EP Application No. 05735008 dated Feb. 28, 2011.
- European Search Report for EP Application No. 05737714 dated Mar. 31, 2009.
- European Search Report for EP Application No. 05734796 dated Apr. 22, 2009.
- European Search Report for EP Application No. 05734947 dated Mar. 20, 2009.
- European Search Report for EP Application No. 05742065 dated Mar. 23, 2009.
- European Search Report for EP Application No. 05745611 dated Mar. 23, 2009.
- European Search Report for EP Application No. 05746428 dated Mar. 24, 2009.
- European Search Report for EP Application No. 05746830 dated Mar. 23, 2009.
- European Search Report for EP Application No. 05753019 dated Mar. 31, 2009.
- European Search Report for EP Application No. 05789280 dated Mar. 23, 2009.
- European Search Report for EP Application No. 05812073 dated Mar. 23, 2009.
- European Search Report for EP Application No. 07813283 dated Oct. 10, 2010.
- Feldman, Susan, "The Answer Machine," *The Magazine for Database Professional*, 8(1):58 (Jan. 2000).
- Computer Hope, "Creating a link without an underline in HTML.;" as evidenced by Internet Archive Wayback Machine: <http://web.archive.org/web/20010329222623/http://www.computerhope.com/iss-ues/ch000074.htm>, Mar. 29, 2001.
- International Search Report for PCT/EP2007/005038 dated Sep. 17, 2007.
- International Search Report for PCT/EP2007/007824 dated May 25, 2009.
- International Search Report for PCT/EP2007/008075 dated Oct. 10, 2008.
- International Search Report for PCT/US2005/011012 dated Sep. 29, 2006.
- International Search Report for PCT/US2005/011013 dated Oct. 19, 2007.
- International Search Report for PCT/US2005/011014 dated May 16, 2007.
- International Search Report for PCT/US2005/011015 dated Dec. 1, 2006.
- International Search Report for PCT/US2005/011016 dated Nov. 9, 2006.
- International Search Report for PCT/US2005/011026 dated Jun. 11, 2007.
- International Search Report for PCT/US2005/011042 dated Sep. 10, 2007.
- International Search Report for PCT/US2005/011043 dated Sep. 20, 2007.
- International Search Report for PCT/US2005/011084 dated Aug. 8, 2008.
- International Search Report for PCT/US2005/011085 dated Sep. 14, 2006.
- International Search Report for PCT/US2005/011088 dated Aug. 29, 2008.
- International Search Report for PCT/US2005/011090 dated Sep. 27, 2006.
- International Search Report for PCT/US2005/011533 dated Jun. 4, 2007.
- International Search Report for PCT/US2005/011534 dated Nov. 9, 2006.
- International Search Report for PCT/US2005/012510 dated Jan. 6, 2011.
- International Search Report for PCT/US2005/013297 dated Aug. 14, 2007.
- International Search Report for PCT/US2005/101193 dated Aug. 7, 2009.
- International Search Report for PCT/US2005/017333 dated Jun. 4, 2007.
- International Search Report for PCT/US2005/029536 dated Apr. 19, 2007.
- International Search Report for PCT/US2005/029537 dated Sep. 28, 2007.
- International Search Report for PCT/US2005/029539 dated Sep. 29, 2008.
- International Search Report for PCT/US2005/029680 dated Jul. 13, 2010.
- International Search Report for PCT/US2005/030007 dated Mar. 11, 2008.
- International Search Report for PCT/US2005/029534 dated May 15, 2007.
- International Search Report for PCT/US2005/034319 dated Apr. 17, 2006.
- International Search Report for PCT/US2005/034734 dated Apr. 4, 2006.
- International Search Report for PCT/US2006/007108 dated Oct. 30, 2007.
- International Search Report for PCT/US2006/018198 dated Sep. 25, 2007.
- International Search Report for PCT/US2007/074214 dated Sep. 9, 2008.
- International Search Report for PCT/US2010/000497 dated Aug. 26, 2010.
- International Search Report for PCT/US2010/000498 dated Aug. 2, 2010.
- International Search Report for PCT/US2010/000499 dated Aug. 31, 2010.

- International Search Report for PCT/US2010/027254 dated Oct. 22, 2010.
- International Search Report for PCT/US2010/027255 dated Nov. 16, 2010.
- International Search Report for PCT/US2010/027256 dated Nov. 15, 2010.
- International Search Report for PCT/US2010/028066 dated Oct. 26, 2010.
- Ghaly et al., SAMS Teach Yourself EJB in 21 days, Sams Publishing, 2002-2003 (pp. 1-2, 123 and 135).
- Non-Final Office Action for U.S. Appl. No. 11/004,637 dated Apr. 2, 2009.
- Notice of Allowance for U.S. Appl. No. 11/004,637 dated Dec. 11, 2009.
- Non-Final Office Action for U.S. Appl. No. 11/096,704 dated Sep. 10, 2008.
- Notice of Allowance for U.S. Appl. No. 11/096,704 dated Mar. 11, 2009.
- Notice of Allowance for U.S. Appl. No. 11/096,704 dated Jun. 5, 2009.
- Non-Final Office Action for U.S. Appl. No. 11/097,089 dated Dec. 23, 2009.
- Final Office Action for U.S. Appl. No. 11/097,089 dated Mar. 17, 2009.
- Final Office Action for U.S. Appl. No. 11/097,089 dated Sep. 23, 2010.
- Notice of Allowance for U.S. Appl. No. 11/097,103 dated May 14, 2009.
- Notice of Allowance for U.S. Appl. No. 11/097,828 dated Feb. 5, 2010.
- Final Office Action for U.S. Appl. No. 11/097,833 dated Jul. 7, 2009.
- Notice of Allowance for U.S. Appl. No. 11/097,833 dated Jan. 10, 2011.
- Final Office Action for U.S. Appl. No. 11/097,835 dated Dec. 29, 2009.
- Notice of Allowance for U.S. Appl. No. 11/097,835 dated Sep. 1, 2010.
- Non-Final Office Action for U.S. Appl. No. 11/097,836 dated Jul. 30, 2009.
- Final Office Action for U.S. Appl. No. 11/097,836 dated May 13, 2010.
- Final Office Action for U.S. Appl. No. 11/097,961 dated Mar. 5, 2009.
- Final Office Action for U.S. Appl. No. 11/097,961 dated Dec. 9, 2009.
- Non-Final Office Action for U.S. Appl. No. 11/097,961 dated Jul. 9, 2010.
- Non-Final Office Action for U.S. Appl. No. 11/098,014 dated Jun. 30, 2009.
- Non-Final Office Action for U.S. Appl. No. 11/098,014 dated Nov. 3, 2010.
- Final Office Action for U.S. Appl. No. 11/098,014 dated Mar. 26, 2010.
- Notice of Allowance for U.S. Appl. No. 11/098,014 dated Mar. 16, 2011.
- Notice of Allowance for U.S. Appl. No. 11/098,016 dated Apr. 22, 2008.
- Notice of Allowance for U.S. Appl. No. 11/098,038 dated May 29, 2009.
- Final Office Action for U.S. Appl. No. 11/098,043 dated Jul. 21, 2009.
- Non-Final Office Action for U.S. Appl. No. 11/110,353 dated Sep. 15, 2009.
- Notice of Allowance for U.S. Appl. No. 11/110,353 dated Dec. 2, 2009.
- Notice of Allowance for U.S. Appl. No. 11/131,945 dated Oct. 30, 2009.
- Non-Final Office Action for U.S. Appl. No. 11/185,908 dated Dec. 14, 2009.
- Final Office Action for U.S. Appl. No. 11/185,908 dated Jun. 28, 2010.
- Non-Final Office Action for U.S. Appl. No. 11/208,408 dated Apr. 23, 2010.
- Notice of Allowance for U.S. Appl. No. 11/208,458 dated Jun. 2, 2008.
- Non-Final Office Action for U.S. Appl. No. 11/208,461 dated Sep. 29, 2009.
- Non-Final Office Action for U.S. Appl. No. 11/208,461 dated Nov. 3, 2010.
- Notice of Allowance for U.S. Appl. No. 11/208,461 dated Mar. 15, 2011.
- Non-Final Office Action for U.S. Appl. No. 11/209,333 dated Apr. 29, 2010.
- Notice of Allowance for U.S. Appl. No. 11/210,260 dated Jan. 13, 2010.
- Non-Final Office Action for U.S. Appl. No. 11/236,330 dated Dec. 2, 2009.
- Notice of Allowance for U.S. Appl. No. 11/236,330 dated Jun. 22, 2010.
- Final Office Action for U.S. Appl. No. 11/236,440 dated Jul. 22, 2009.
- Non-Final Office Action for U.S. Appl. No. 11/365,983 dated Jan. 26, 2010.
- Final Office Action for U.S. Appl. No. 11/365,983 dated Sep. 14, 2010.
- Non-Final Office Action for U.S. Appl. No. 11/547,835 dated Dec. 29, 2010.
- Non-Final Office Action for U.S. Appl. No. 11/672,014 dated May 6, 2010.
- Notice of Allowance for U.S. Appl. No. 11/672,014 dated Feb. 28, 2011.
- Non-Final Office Action for U.S. Appl. No. 11/758,866 dated Jun. 14, 2010.
- Non-Final Office Action for U.S. Appl. No. 11/972,562 dated Apr. 21, 2010.
- Non-Final Office Action for U.S. Appl. No. 12/538,731 dated Jun. 28, 2010.
- Notice of Allowance for U.S. Appl. No. 12/538,731 dated Oct. 8, 2010.
- Non-Final Office Action for U.S. Appl. No. 12/541,891 dated Dec. 9, 2010.
- Non-Final Office Action for U.S. Appl. No. 12/542,816 dated Jun. 18, 2010.
- Notice of Allowance for U.S. Appl. No. 12/542,816 dated Jan. 3, 2011.
- Non-Final Office Action for U.S. Appl. No. 12/721,456 dated Mar. 1, 2011.
- Image Sensors—Capturing the Photograph, <http://www.shortcourses.com/how/sensors/sensors.htm>, 19 pages (Sep. 4, 2006).
- King et al., U.S. Appl. No. 11/432,731, filed May 11, 2006.
- King et al., U.S. Appl. No. 11/933,204, filed Oct. 21, 2007.
- King et al., U.S. Appl. No. 11/952,885, filed Dec. 7, 2007.
- King et al., U.S. Appl. No. 12/517,352, filed Jun. 2, 2009.
- King et al., U.S. Appl. No. 12/517,541, filed Jun. 3, 2009.
- King et al., U.S. Appl. No. 12/723,614, filed, Mar. 12, 2010.
- King et al., U.S. Appl. No. 12/728,144, filed Mar. 19, 2010.
- King et al., U.S. Appl. No. 12/831,213, filed Jul. 6, 2010.
- King et al., U.S. Appl. No. 12/884,139, filed Sep. 6, 2010.
- King et al., U.S. Appl. No. 12/887,473, filed Sep. 21, 2010.
- King et al., U.S. Appl. No. 12/889,321, filed Sep. 23, 2010.
- King et al., U.S. Appl. No. 12/892,840, filed Sep. 28, 2010.
- King et al., U.S. Appl. No. 12/894,059, filed Sep. 29, 2010.
- King et al., U.S. Appl. No. 12/899,462, filed Oct. 6, 2010.
- King et al., U.S. Appl. No. 12/902,081, filed Oct. 11, 2010.
- King et al., U.S. Appl. No. 12/904,064, filed Oct. 13, 2010.
- King et al., U.S. Appl. No. 12/961,407, filed Dec. 6, 2010.
- King et al., U.S. Appl. No. 12/964,662, filed Dec. 9, 2010.
- King et al., U.S. Appl. No. 13/031,316, filed Feb. 21, 2011.
- European Search Report for EP Application No. 05732913 dated Mar. 31, 2009.
- European Search Report for EP Application No. 05733915 dated Dec. 30, 2009.
- European Search Report for EP Application No. 07813283 dated Dec. 10, 2010.
- International Search Report for PCT/US2005/011016 dated May 29, 2007.

- International Search Report for PCT/US2005/013586 dated Aug. 7, 2009.
- International Search Report for PCT/US2010/000497 dated Sep. 27, 2010.
- Non-Final Office Action for U.S. Appl. No. 11/097,961 dated Mar. 5, 2009.
- Notice of Allowance for U.S. Appl. No. 12/538,731 dated Oct. 18, 2010.
- Casey et al., "An Autonomous Reading Machine," IEEE Transactions on Computers, vol. C-17, No. 5, pp. 492-503 May 1968.
- Non-Final Office Action for U.S. Appl. No. 12/887,473 dated Feb. 4, 2011.
- Non-Final Office Action for U.S. Appl. No. 12/889,321 dated Mar. 31, 2011.
- Non-Final Office Action for U.S. Appl. No. 12/904,064 dated Mar. 30, 2011.
- Non-Final Office Action for U.S. Appl. No. 11/097,089 dated Apr. 7, 2011.
- Brickman et al., "Word Autocorrelation Redundancy Match (WARM) Technology," IBM J. Res. Develop., 26 (6):681-686 (Jun. 1982).
- Notice of Allowance for U.S. Appl. No. 12/542,816 dated Apr. 27, 2011.
- Caner, Christian. "Wavelet Packets and Optimization in Pattern Recognition." Proceedings of the 21st International Workshop of the AAPR, Hallstatt, Austria, May 1997, 11 pp.
- Clancy, Heather. "Cell Phones Get New Job: Portable Scanning." C/Net News.com, http://news.com.com/2102-1039_13_5572897.html?tag=stutil.print, Accessed Feb. 13, 2005, 3pp.
- Cybertracker. Homepage. <http://www.cybertracker.co.za/>, accessed Oct. 3, 2005, 2pp.
- Digital Convergence. "CueCat." <http://www.cuecat.com>, accessed Oct. 3, 2005, 2 pp.
- Docuport "DocuPen Operating Manual." Montreal, Quebec, 2004, 48pp.
- Doermann, David, Huiping Li, Omid Kia, Kemal Kilic. "The Detection of Duplicates in Document Image Databases." Technical Report. LAMP-TR-005/CAR-TR-850/CS-TR-3739, University of Maryland College Park, Feb. 1997, 39pp.
- Doermann, David, J. Sauvola, H. Kauniskangas, C. Shin, M. Pietikainen & A. Rosenfeld. "The Development of a General Framework for Intelligent Document Image Retrieval." Series in Machine Perception and Artificial Intelligence, vol. 29: Document Analysis Systems 11. Washington DC: World Scientific Press, 1997, 28 pp.
- Doermann, David. "The Indexing and Retrieval of Document Images: A Survey." Technical Report. LAMP-TR-0013/CAR-TR-878/CS-TR-3876. University of Maryland College Park, Feb. 1998, 39 pp.
- Duong, Jean, Myriam Cote, Hubert Emptoz, Ching Y. Suen. "Extraction of Text Areas in Printed Document Images." Proceedings of the 2001 ACM Symposium on Document Engineering. New York, NY: ACM Press, 2001, pp. 157-164.
- eBooks, eBooks Quickstart Guide, nl-487, 2001, 2 pages.
- Environmental Code of Federal Regulation (CFRs) including TSCA and SARA, Solutions Software Corp., Enterprise, FL., cApr 94.
- Erol, Berna, Jonathan J. Hull, and Dar-Shyang Lee. "Linking Multimedia Presentations with their Symbolic Source Documents: Algorithms and Applications." ACM Multimedia. New York, NY: ACM Press, 2003, 10pp.
- Fall, C.J., A. Tórcsvari, K. Benzineb, G. Karetka. "Automated Categorization in the International Patent Classification." ACM SIGIR Forum. vol. 37, Issue 1, Spring 2003: 10-25.
- Fehrenbacher, Katie "Quick Fruccall Could Save You Pennies OR \$\$\$", GIGAOM, <http://gioaom.com/2006/07/10/fruccall>, Jul. 10, 2006.
- Ficstar. Homepage. www.ficstar.com, accessed Oct. 4, 2005, 1p.
- Hong, Tao and Jonathan H. Hull. "Degraded Text Recognition Using Word Collocation and Visual Inter-Word Constraints." Fourth ACL Conference on Applied Natural Language Processing, Stuttgart, Germany, 1994, 2pp.
- Hopkins, George W., and Tad D. Simons. "A Semi-Imaging Light Pipe for Collecting Weakly Scattered Light." Hewlett Packard Company, Jun. 1998, 6 pp.
- Hu, Jianying, Ramanujan Kashi, Gordon Wilfong, "Comparison and Classification of Documents Based on Layout Similarity." Lucent Technologies Bell Labs, Murray Hill, NJ, 2000, 21pp.
- Hull, Jonathan and Dar-Shyang Lee, Simultaneous Highlighting of Paper and Electronic Documents, 02000 IEEE, pp. 401-404.
- Hull, Jonathan J, and Dar-Shyang Lee. "Simultaneous Highlighting of Paper and Electronic Documents." Proceedings of the International Conference on Pattern Recognition (ICPR '001, vol. 4. Barcelona, 2000, pp. 401-404.
- Hull, Jonathan J, Dar-Shyang Lee, John Cullen, Peter E Hart. "Document Analysis Techniques for the Infinite Memory Multifunction Machine." DEXA Workshop, 1999. <http://www.informatik.uni-trier.de/Hey/db/conf/dexaw/dexaw99.html>, 5pp.
- Inglis, Stuart and Ian H. Witten. "Compression-Based Template Matching." University of Waikato, Hamilton, New Zealand, 1994, 10 pp.
- International Search Report for International Application No. PCT/US05/25732 mailed Dec. 5, 2005; Applicant: ExBiblio B.V., 9 pgs.
- IPValue Management, Xerox Research Centre Europe. "Technology Licensing Opportunity: Xerox Mobile Camera Document Imaging." Slideshow, Mar. 1, 2004, 11 pp.
- ISRI Staff. "OCR Accuracy Produced By the Current DOE Document Conversion System." Technical Report 2002-06, Information Science Research Institute at the University of Nevada, Las Vegas. May 2002, 9pp.
- Jacobson et al., "The Last Book", IBM Systems Journal, vol. 36, No. 3, 1997, pp. 457-463.
- Jainschigg, John and Richard "Zippy" Grigonis, "M-Commerce Alternatives," Communications Convergence.com, <http://www.c.convergence.com/shared/article/showArticle.jhtml?articleId=8701069>, May 7, 2001, 14pp.
- Janesick, James. "Dueling Detectors." Spie's OE Magazine. Feb. 2002: 30-33.
- Jenny, Reinhard. "Fundamentals of Fiber Optics: An Introduction for Beginners." Technical Report for Volpi AG, Apr. 26, 2000. <http://www.volpiusa.com/whitepapers/FundamentalsofFiberOptics.pdf>, 23pp.
- Notice of Allowance for U.S. Appl. No. 11/097,981 dated Jul. 31, 2009.
- King et al., U.S. Appl. No. 13/186,908 filed Jul. 20, 2011, all pages.
- King et al., U.S. Appl. No. 13/253,632 filed Oct. 5, 2011, all pages.
- Bagley, et al., Editing Images of Text, Communications of the ACM, 37(12):63-72 (Dec. 1994).
- Liddy, Elizabeth, "How a Search Engine Works," InfoToday.com, vol. 9, No. 5, May 2001, pp. 1-7.
- Brin et al., "The Anatomy of a Large-Scale Hyper-textual Web Search Engine," Computer Networks and ISDN Systems, Vo. 30, Issue 1-7, Apr. 1, 1998, pp. 1-22.
- Bahl, et al., "Font Independent Character Recognition by Cryptanalysis." IBM Technical Disclosure Bulletin, vol. 24, No. 3, pp. 1588-1589 (Aug. 1, 1981).
- Garain et al., "Compression of Scan-Digitized Indian Language Printed Text: A Soft Pattern Matching Technique," Proceedings of the 2003 ACM Symposium on Document Engineering, pp. 185-192 (Jan. 1, 2003).
- Nagy et al., "Decoding Substitution Ciphers by Means of Word Matching with Application to OCR," IEEE Transactions on Pattern Analysis and Machine Intelligence, vol. 30, No. 5, pp. 710-715 (Sep. 1, 1987).
- Ramesh, R.S. et al., "An Automated Approach to Solve Simple Substitution Ciphers," Cryptologia, vol. 17, No. 2, pp. 202-218 (1993).
- Wood et al., "Implementing a faster string search algorithm in Ada," CM Sigada Ada Letters, vol. 8, No. 3, pp. 87-97 (Apr. 1, 1988).
- King et al., U.S. Appl. No. 13/614,770, filed on Sep. 13, 2012, 102 pages.
- King et al., U.S. Appl. No. 13/614,473, filed on Sep. 13, 2012, 120 pages.
- King et al., U.S. Appl. No. 13/615,517, filed on Sep. 13, 2012, 114 pages.

* cited by examiner

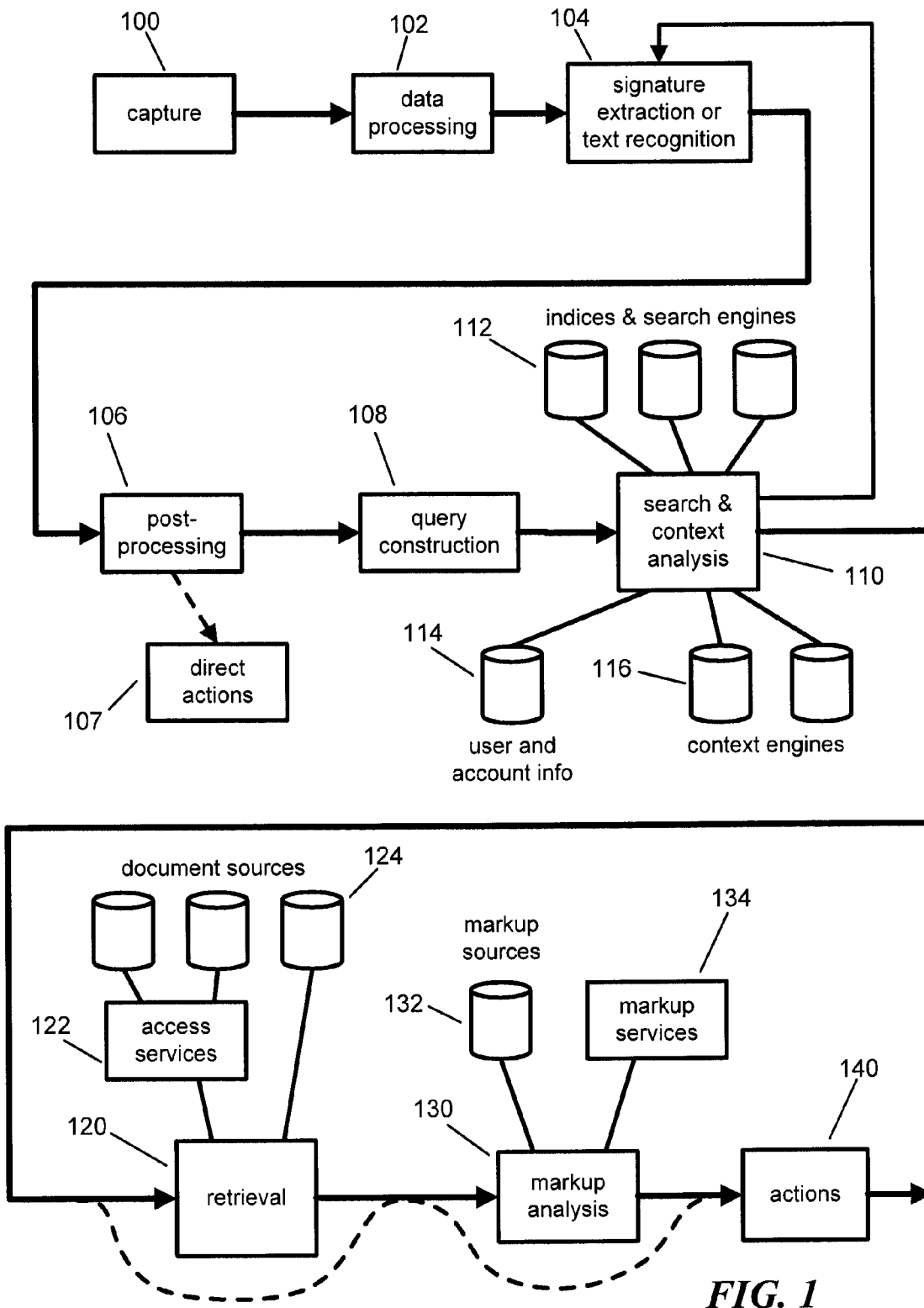

FIG. 1

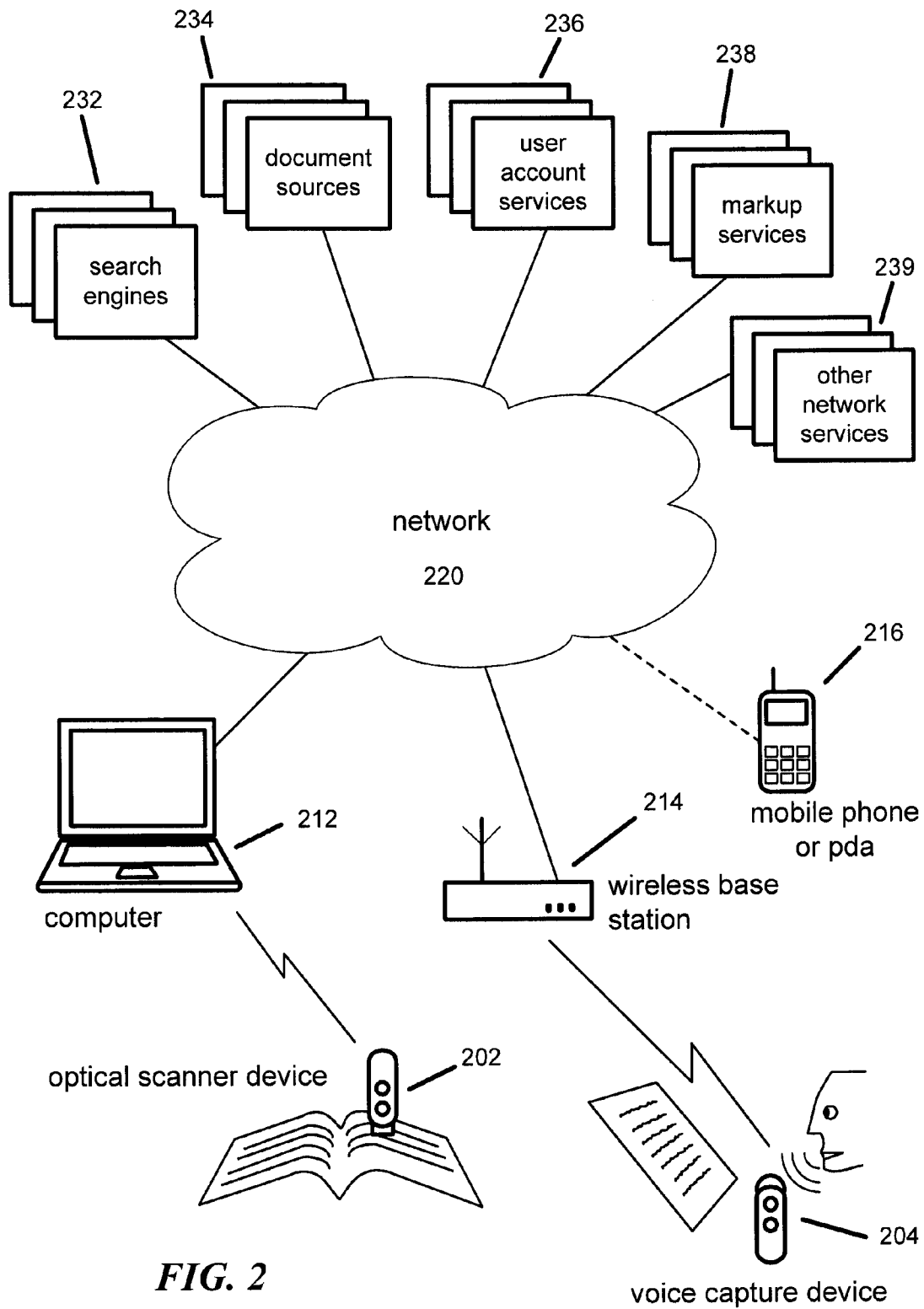

FIG. 2

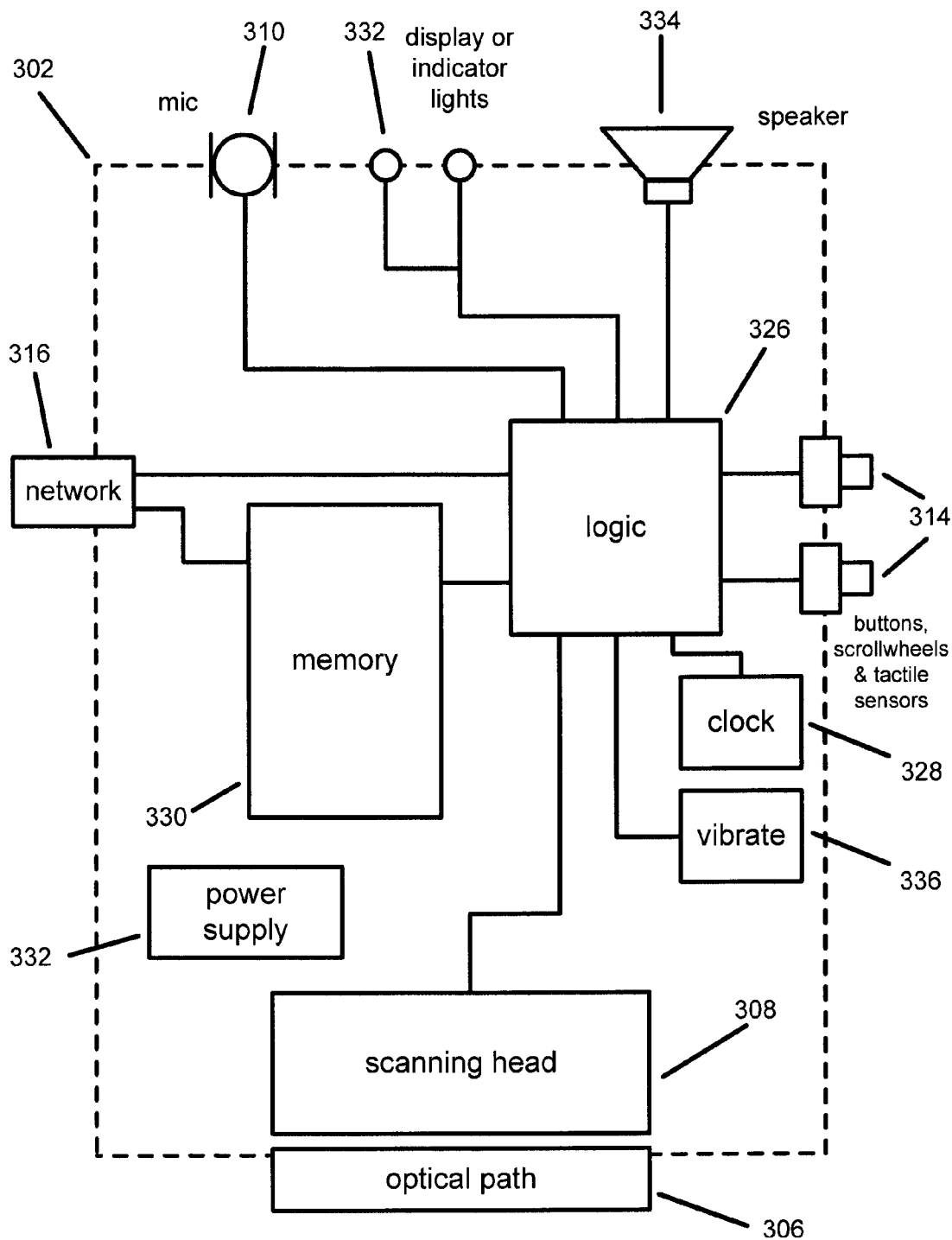

FIG. 3

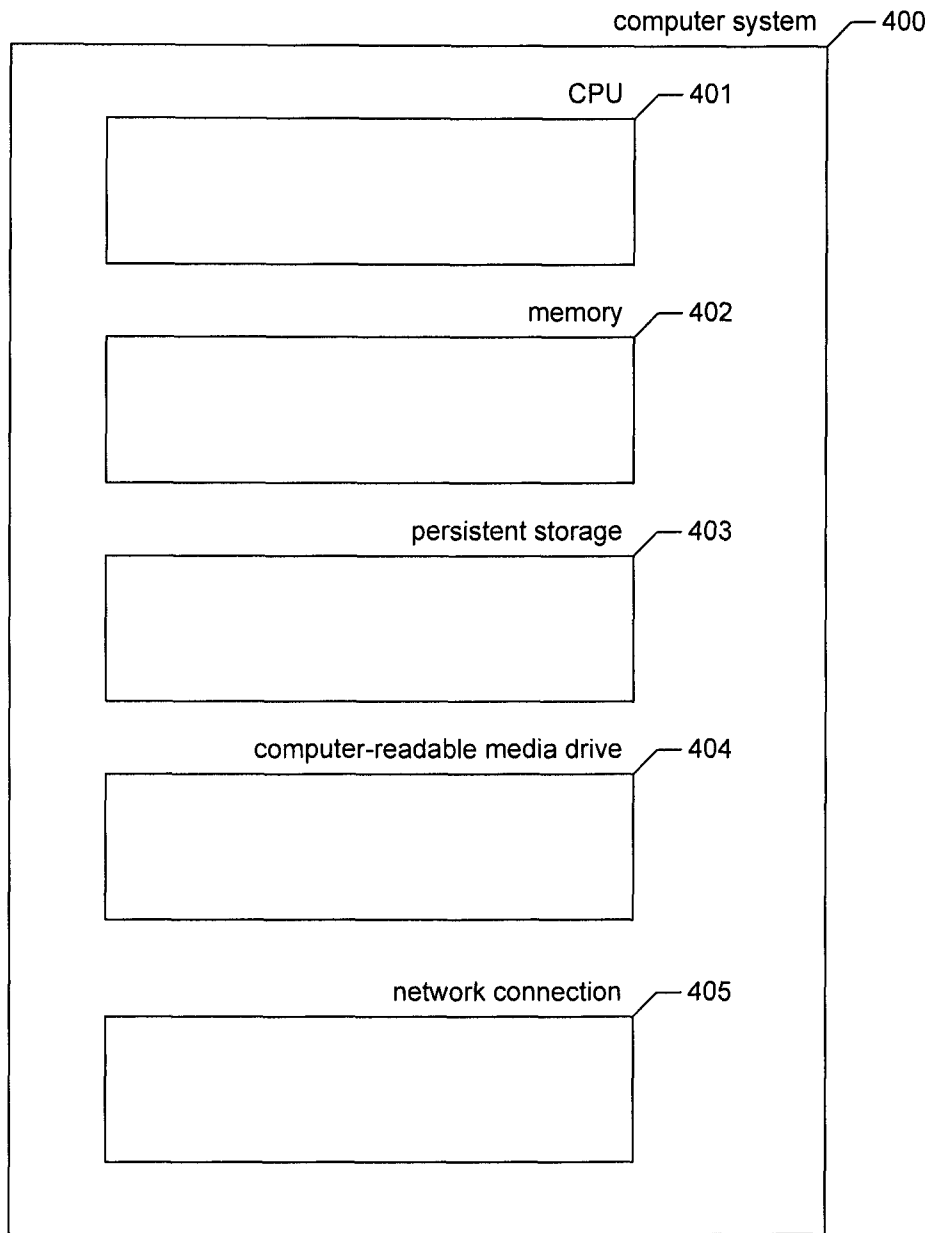

FIG. 4

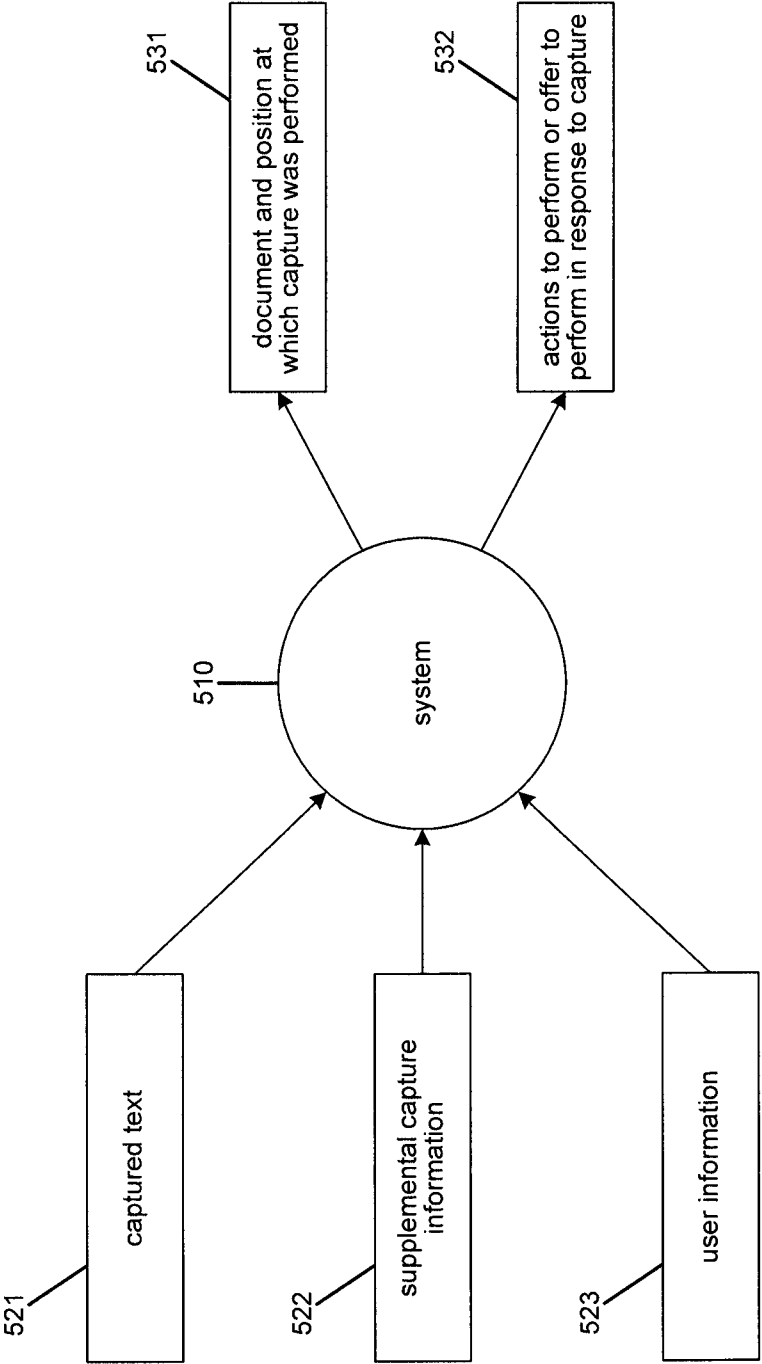

FIG. 5

**CAPTURING TEXT FROM RENDERED
DOCUMENTS USING SUPPLEMENTAL
INFORMATION**

CROSS-REFERENCE TO RELATED
APPLICATIONS

This application is a continuation of 11/096,704 filed on Apr. 1, 2005 which is now U.S. Pat. No. 7,599,580, which is a Continuation-In-Part of U.S. patent application Ser. No. 11/004,637 filed on Dec. 3, 2004 now U.S. Pat. No. 7,707,039, which are hereby incorporated by reference in their entirety.

This application is related to, and incorporates by reference in their entirety, the following U.S. patent applications, filed concurrently herewith: U.S. patent application Ser. No. 11/097,961, entitled METHODS AND SYSTEMS FOR INITIATING APPLICATION PROCESSES BY DATA CAPTURE FROM RENDERED DOCUMENTS, U.S. patent application Ser. No. 11/097,093, entitled DETERMINING ACTIONS INVOLVING CAPTURED INFORMATION AND ELECTRONIC CONTENT ASSOCIATED WITH RENDERED DOCUMENTS, U.S. patent application Ser. No. 11/098,038, entitled CONTENT ACCESS WITH HANDHELD DOCUMENT DATA CAPTURE DEVICES, U.S. patent application Ser. No. 11/098,014, entitled SEARCH ENGINES AND SYSTEMS WITH HANDHELD DOCUMENT DATA CAPTURE DEVICES, U.S. patent application Ser. No. 11/097,103, entitled TRIGGERING ACTIONS IN RESPONSE TO OPTICALLY OR ACOUSTICALLY CAPTURING KEYWORDS FROM A RENDERED DOCUMENT, U.S. patent application Ser. No. 11/098,043, entitled SEARCHING AND ACCESSING DOCUMENTS ON PRIVATE NETWORKS FOR USE WITH CAPTURES FROM RENDERED DOCUMENTS, U.S. patent application Ser. No. 11/097,981, entitled INFORMATION GATHERING SYSTEM AND METHOD, U.S. patent application Ser. No. 11/097,089, entitled DOCUMENT ENHANCEMENT SYSTEM AND METHOD, U.S. patent application Ser. No. 11/097,835, entitled PUBLISHING TECHNIQUES FOR ADDING VALUE TO A RENDERED DOCUMENT, U.S. patent application Ser. No. 11/098,016, entitled ARCHIVE OF TEXT CAPTURES FROM RENDERED DOCUMENTS, U.S. patent application Ser. No. 11/097,828, entitled ADDING INFORMATION OR FUNCTIONALITY TO A RENDERED DOCUMENT VIA ASSOCIATION WITH AN ELECTRONIC COUNTERPART, U.S. patent application Ser. No. 11/097,833, entitled AGGREGATE ANALYSIS OF TEXT CAPTURES PERFORMED BY MULTIPLE USERS FROM RENDERED DOCUMENTS, U.S. patent application Ser. No. 11/097,836, entitled ESTABLISHING AN INTERACTIVE ENVIRONMENT FOR RENDERED DOCUMENTS, and U.S. patent application Ser. No. 11/098,042, entitled DATA CAPTURE FROM RENDERED DOCUMENTS USING HANDHELD DEVICE.

This application claims priority to, and incorporates by reference in their entirety, the following U.S. Provisional Patent Applications: Application No. 60/559,226 filed on Apr. 1, 2004, Application No. 60/558,893 filed on Apr. 1, 2004, Application No. 60/558,968 filed on Apr. 1, 2004, Application No. 60/558,867 filed on Apr. 1, 2004, Application No. 60/559,278 filed on Apr. 1, 2004, Application No. 60/559,279 filed on Apr. 1, 2004, Application No. 60/559,265 filed on Apr. 1, 2004, Application No. 60/559,277 filed on Apr. 1, 2004, Application No. 60/558,969 filed on Apr. 1, 2004, Application No. 60/558,892 filed on Apr. 1, 2004,

Application No. 60/558,760 filed on Apr. 1, 2004, Application No. 60/558,717 filed on Apr. 1, 2004, Application No. 60/558,499 filed on Apr. 1, 2004, Application No. 60/558,370 filed on Apr. 1, 2004, Application No. 60/558,789 filed on Apr. 1, 2004, Application No. 60/558,791 filed on Apr. 1, 2004, Application No. 60/558,527 filed on Apr. 1, 2004, Application No. 60/559,125 filed on Apr. 2, 2004, Application No. 60/558,909 filed on Apr. 2, 2004, Application No. 60/559,033 filed on Apr. 2, 2004, Application No. 60/559,127 filed on Apr. 2, 2004, Application No. 60/559,087 filed on Apr. 2, 2004, Application No. 60/559,131 filed on Apr. 2, 2004, Application No. 60/559,766 filed on Apr. 6, 2004, Application No. 60/561,768 filed on Apr. 12, 2004, Application No. 60/563,520 filed on Apr. 19, 2004, Application No. 60/563,485 filed on Apr. 19, 2004, Application No. 60/564,688 filed on Apr. 23, 2004, Application No. 60/564,846 filed on Apr. 23, 2004, Application No. 60/556,667 filed on Apr. 30, 2004, Application No. 60/571,381 filed on May 14, 2004, Application No. 60/571,560 filed on May 14, 2004, Application No. 60/571,715 filed on May 17, 2004, Application No. 60/589,203 filed on Jul. 19, 2004, Application No. 60/589,201 filed on Jul. 19, 2004, Application No. 60/589,202 filed on Jul. 19, 2004, Application No. 60/598,821 filed on Aug. 2, 2004, Application No. 60/602,956 filed on Aug. 18, 2004, Application No. 60/602,925 filed on Aug. 18, 2004, Application No. 60/602,947 filed on Aug. 18, 2004, Application No. 60/602,897 filed on Aug. 18, 2004, Application No. 60/602,896 filed on Aug. 18, 2004, Application No. 60/602,930 filed on Aug. 18, 2004, Application No. 60/602,898 filed on Aug. 18, 2004, Application No. 60/603,466 filed on Aug. 19, 2004, Application No. 60/603,082 filed on Aug. 19, 2004, Application No. 60/603,081 filed on Aug. 19, 2004, Application No. 60/603,358 filed on Aug. 20, 2004, Application No. 60/604,103 filed on Aug. 23, 2004, Application No. 60/604,098 filed on Aug. 23, 2004, Application No. 60/604,100 filed on Aug. 23, 2004, Application No. 60/604,102 filed on Aug. 23, 2004, Application No. 60/605,229 filed on Aug. 27, 2004, Application No. 60/605,105 filed on Aug. 27, 2004, Application No. 60/613,243 filed on Sep. 27, 2004, Application No. 60/613,628 filed on Sep. 27, 2004, Application No. 60/613,632 filed on Sep. 27, 2004, Application No. 60/613,589 filed on Sep. 27, 2004, Application No. 60/613,242 filed on Sep. 27, 2004, Application No. 60/613,602 filed on Sep. 27, 2004, Application No. 60/613,340 filed on Sep. 27, 2004, Application No. 60/613,634 filed on Sep. 27, 2004, Application No. 60/613,461 filed on Sep. 27, 2004, Application No. 60/613,455 filed on Sep. 27, 2004, Application No. 60/613,460 filed on Sep. 27, 2004, Application No. 60/613,400 filed on Sep. 27, 2004, Application No. 60/613,456 filed on Sep. 27, 2004, Application No. 60/613,341 filed on Sep. 27, 2004, Application No. 60/613,361 filed on Sep. 27, 2004, Application No. 60/613,454 filed on Sep. 27, 2004, Application No. 60/613,339 filed on Sep. 27, 2004, Application No. 60/613,633 filed on Sep. 27, 2004, Application No. 60/615,378 filed on Oct. 1, 2004, Application No. 60/615,112 filed on Oct. 1, 2004, Application No. 60/617,122 filed on Oct. 7, 2004, Application No. 60/622,906 filed on Oct. 28, 2004, Application No. 60/633,452 filed on Dec. 6, 2004, Application No. 60/633,678 filed on Dec. 6, 2004, Application No. 60/633,486 filed on Dec. 6, 2004, Application No. 60/633,453 filed on Dec. 6, 2004, Application No. 60/634,627 filed on Dec. 9, 2004, Application No. 60/634,739 filed on Dec. 9, 2004, Application No. 60/647,684 filed on Jan. 26, 2005, Application No. 60/648,746 filed on Jan. 31, 2005, Application No. 60/653,372 filed on Feb. 15, 2005, Application No. 60/653,663 filed on Feb. 16, 2005, Applica-

tion No. 60/653,669 filed on Feb. 16, 2005, Application No. 60/653,899 filed on Feb. 16, 2005, Application No. 60/653,679 filed on Feb. 16, 2005, Application No. 60/653,847 filed on Feb. 16, 2005, Application No. 60/654,379 filed on Feb. 17, 2005, Application No. 60/654,368 filed on Feb. 18, 2005, Application No. 60/654,326 filed on Feb. 18, 2005, Application No. 60/654,196 filed on Feb. 18, 2005, Application No. 60/655,279 filed on Feb. 22, 2005, Application No. 60/655,280 filed on Feb. 22, 2005, Application No. 60/655,987 filed on Feb. 22, 2005, Application No. 60/655,697 filed on Feb. 22, 2005, Application No. 60/655,281 filed on Feb. 22, 2005, and Application No. 60/657,309 filed on Feb. 28, 2005.

TECHNICAL FIELD

The described technology is directed to the field of document processing.

BACKGROUND

Paper documents have an enduring appeal, as can be seen by the proliferation of paper documents in the computer age. It has never been easier to print and publish paper documents than it is today. Paper documents prevail even though electronic documents are easier to duplicate, transmit, search and edit.

Given the popularity of paper documents and the advantages of electronic documents, it would be useful to combine the benefits of both.

BRIEF DESCRIPTION OF THE DRAWINGS

FIG. 1 is a data flow diagram that illustrates the flow of information in one embodiment of the system.

FIG. 2 is a component diagram of components included in a typical implementation of the system in the context of a typical operating environment.

FIG. 3 is a block diagram of an embodiment of a scanner.

FIG. 4 is a block diagram showing some of the components typically incorporated in at least some of the computer systems and other devices used by the system.

FIG. 5 is a data flow diagram showing a typical manner in which the system uses context information.

DETAILED DESCRIPTION

Overview

A system for capturing text from rendered documents using supplemental information ("the system") is described.

In some embodiments, the system captures text from a rendered document and associates some action, data, or functionality with that capture. Section 13 introduces the idea of using supplemental information about the circumstances under which a capture is performed, together with supplemental information about the user who performed the capture (sometimes collectively called "context"), as well as the data actually captured, to interpret the meaning of the capture and to determine the associations and actions that should appropriately follow. This is in contrast, for example, to conventional web search engines, which typically maintain very little context information from one search invocation to another, and know little about the circumstances under which the search query was performed.

By considering context, the system can reduce many degrees of uncertainty in its processes. For example, if the captured data could have come from any of several documents, the system can utilize the context to discard many that

would be highly unlikely and help prioritize those that remain. Similarly, if the source of a capture is recognized but there are many actions that the user may wish to take as a result, the context can be a valuable aid in deciding which one should be the default. The uses to which the system puts context in various embodiments are discussed in more detail below.

Part I—Introduction

1. Nature of the System

For every paper document that has an electronic counterpart, there exists a discrete amount of information in the paper document that can identify the electronic counterpart. In some embodiments, the system uses a sample of text captured from a paper document, for example using a handheld scanner, to identify and locate an electronic counterpart of the document. In most cases, the amount of text needed by the facility is very small in that a few words of text from a document can often function as an identifier for the paper document and as a link to its electronic counterpart. In addition, the system may use those few words to identify not only the document, but also a location within the document.

Thus, paper documents and their digital counterparts can be associated in many useful ways using the system discussed herein.

1.1. A Quick Overview of the Future

Once the system has associated a piece of text in a paper document with a particular digital entity has been established, the system is able to build a huge amount of functionality on that association.

It is increasingly the case that most paper documents have an electronic counterpart that is accessible on the World Wide Web or from some other online database or document corpus, or can be made accessible, such as in response to the payment of a fee or subscription. At the simplest level, then, when a user scans a few words in a paper document, the system can retrieve that electronic document or some part of it, or display it, email it to somebody, purchase it, print it or post it to a web page. As additional examples, scanning a few words of a book that a person is reading over breakfast could cause the audiobook version in the person's car to begin reading from that point when s/he starts driving to work, or scanning the serial number on a printer cartridge could begin the process of ordering a replacement.

The system implements these and many other examples of "paper/digital integration" without requiring changes to the current processes of writing, printing and publishing documents, giving such conventional rendered documents a whole new layer of digital functionality.

1.2. Terminology

A typical use of the system begins with using an optical scanner to scan text from a paper document, but it is important to note that other methods of capture from other types of document are equally applicable. The system is therefore sometimes described as scanning or capturing text from a rendered document, where those terms are defined as follows:

A rendered document is a printed document or a document shown on a display or monitor. It is a document that is perceptible to a human, whether in permanent form or on a transitory display.

Scanning or capturing is the process of systematic examination to obtain information from a rendered document. The process may involve optical capture using a scanner or camera (for example a camera in a cellphone), or it may involve reading aloud from the document into an audio capture device or typing it on a keypad or keyboard. For more examples, see Section 15.

2. Introduction to the System

This section describes some of the devices, processes and systems that constitute a system for paper/digital integration. In various embodiments, the system builds a wide variety of services and applications on this underlying core that provides the basic functionality.

2.1. The Processes

FIG. 1 is a data flow diagram that illustrates the flow of information in one embodiment of the core system. Other embodiments may not use all of the stages or elements illustrated here, while some will use many more.

Text from a rendered document is captured **100**, typically in optical form by an optical scanner or audio form by a voice recorder, and this image or sound data is then processed **102**, for example to remove artifacts of the capture process or to improve the signal-to-noise ratio. A recognition process **104** such as OCR, speech recognition, or autocorrelation then converts the data into a signature, comprised in some embodiments of text, text offsets, or other symbols. Alternatively, the system performs an alternate form of extracting document signature from the rendered document. The signature represents a set of possible text transcriptions in some embodiments. This process may be influenced by feedback from other stages, for example, if the search process and context analysis **110** have identified some candidate documents from which the capture may originate, thus narrowing the possible interpretations of the original capture.

A post-processing **106** stage may take the output of the recognition process and filter it or perform such other operations upon it as may be useful. Depending upon the embodiment implemented, it may be possible at this stage to deduce some direct actions **107** to be taken immediately without reference to the later stages, such as where a phrase or symbol has been captured which contains sufficient information in itself to convey the user's intent. In these cases no digital counterpart document need be referenced, or even known to the system.

Typically, however, the next stage will be to construct a query **108** or a set of queries for use in searching. Some aspects of the query construction may depend on the search process used and so cannot be performed until the next stage, but there will typically be some operations, such as the removal of obviously misrecognized or irrelevant characters, which can be performed in advance.

The query or queries are then passed to the search and context analysis stage **110**. Here, the system optionally attempts to identify the document from which the original data was captured. To do so, the system typically uses search indices and search engines **112**, knowledge about the user **114** and knowledge about the user's context or the context in which the capture occurred **116**. Search engine **112** may employ and/or index information specifically about rendered documents, about their digital counterpart documents, and about documents that have a web (internet) presence). It may write to, as well as read from, many of these sources and, as has been mentioned, it may feed information into other stages of the process, for example by giving the recognition system **104** information about the language, font, rendering and likely next words based on its knowledge of the candidate documents.

In some circumstances the next stage will be to retrieve **120** a copy of the document or documents that have been identified. The sources of the documents **124** may be directly accessible, for example from a local filing system or database or a web server, or they may need to be contacted via some access service **122** which might enforce authentication, security or

payment or may provide other services such as conversion of the document into a desired format.

Applications of the system may take advantage of the association of extra functionality or data with part or all of a document. For example, advertising applications discussed in Section 10.4 may use an association of particular advertising messages or subjects with portions of a document. This extra associated functionality or data can be thought of as one or more overlays on the document, and is referred to herein as "markup". The next stage of the process **130**, then, is to identify any markup relevant to the captured data. Such markup may be provided by the user, the originator, or publisher of the document, or some other party, and may be directly accessible from some source **132** or may be generated by some service **134**. In various embodiments, markup can be associated with, and apply to, a rendered document and/or the digital counterpart to a rendered document, or to groups of either or both of these documents.

Lastly, as a result of the earlier stages, some actions may be taken **140**. These may be default actions such as simply recording the information found, they may be dependent on the data or document, or they may be derived from the markup analysis. Sometimes the action will simply be to pass the data to another system. In some cases the various possible actions appropriate to a capture at a specific point in a rendered document will be presented to the user as a menu on an associated display, for example on a local display **332**, on a computer display **212** or a mobile phone or PDA display **216**. If the user doesn't respond to the menu, the default actions can be taken.

2.2. The Components

FIG. 2 is a component diagram of components included in a typical implementation of the system in the context of a typical operating environment. As illustrated, the operating environment includes one or more optical scanning capture devices **202** or voice capture devices **204**. In some embodiments, the same device performs both functions. Each capture device is able to communicate with other parts of the system such as a computer **212** and a mobile station **216** (e.g., a mobile phone or PDA) using either a direct wired or wireless connection, or through the network **220**, with which it can communicate using a wired or wireless connection, the latter typically involving a wireless base station **214**. In some embodiments, the capture device is integrated in the mobile station, and optionally shares some of the audio and/or optical components used in the device for voice communications and picture-taking.

Computer **212** may include a memory containing computer executable instructions for processing an order from scanning devices **202** and **204**. As an example, an order can include an identifier (such as a serial number of the scanning device **202/204** or an identifier that partially or uniquely identifies the user of the scanner), scanning context information (e.g., time of scan, location of scan, etc.) and/or scanned information (such as a text string) that is used to uniquely identify the document being scanned. In alternative embodiments, the operating environment may include more or less components.

Also available on the network **220** are search engines **232**, document sources **234**, user account services **236**, markup services **238** and other network services **239**. The network **220** may be a corporate intranet, the public Internet, a mobile phone network or some other network, or any interconnection of the above.

Regardless of the manner by which the devices are coupled to each other, they may all may be operable in accordance with well-known commercial transaction and communication protocols (e.g., Internet Protocol (IP)). In various

embodiments, the functions and capabilities of scanning device **202**, computer **212**, and mobile station **216** may be wholly or partially integrated into one device. Thus, the terms scanning device, computer, and mobile station can refer to the same device depending upon whether the device incorporates functions or capabilities of the scanning device **202**, computer **212** and mobile station **216**. In addition, some or all of the functions of the search engines **232**, document sources **234**, user account services **236**, markup services **238** and other network services **239** may be implemented on any of the devices and/or other devices not shown.

2.3. The Capture Device

As described above, the capture device may capture text using an optical scanner that captures image data from the rendered document, or using an audio recording device that captures a user's spoken reading of the text, or other methods. Some embodiments of the capture device may also capture images, graphical symbols and icons, etc., including machine readable codes such as barcodes. The device may be exceedingly simple, consisting of little more than the transducer, some storage, and a data interface, relying on other functionality residing elsewhere in the system, or it may be a more full-featured device. For illustration, this section describes a device based around an optical scanner and with a reasonable number of features.

Scanners are well known devices that capture and digitize images. An offshoot of the photocopier industry, the first scanners were relatively large devices that captured an entire document page at once. Recently, portable optical scanners have been introduced in convenient form factors, such as a pen-shaped handheld device.

In some embodiments, the portable scanner is used to scan text, graphics, or symbols from rendered documents. The portable scanner has a scanning element that captures text, symbols, graphics, etc, from rendered documents. In addition to documents that have been printed on paper, in some embodiments, rendered documents include documents that have been displayed on a screen such as a CRT monitor or LCD display.

FIG. 3 is a block diagram of an embodiment of a scanner **302**. The scanner **302** comprises an optical scanning head **308** to scan information from rendered documents and convert it to machine-compatible data, and an optical path **306**, typically a lens, an aperture or an image conduit to convey the image from the rendered document to the scanning head. The scanning head **308** may incorporate a Charge-Coupled Device (CCD), a Complementary Metal Oxide Semiconductor (CMOS) imaging device, or an optical sensor of another type.

A microphone **310** and associated circuitry convert the sound of the environment (including spoken words) into machine-compatible signals, and other input facilities exist in the form of buttons, scroll-wheels or other tactile sensors such as touch-pads **314**.

Feedback to the user is possible through a visual display or indicator lights **332**, through a loudspeaker or other audio transducer **334** and through a vibrate module **336**.

The scanner **302** comprises logic **326** to interact with the various other components, possibly processing the received signals into different formats and/or interpretations. Logic **326** may be operable to read and write data and program instructions stored in associated storage **330** such as RAM, ROM, flash, or other suitable memory. It may read a time signal from the clock unit **328**. The scanner **302** also includes an interface **316** to communicate scanned information and other signals to a network and/or an associated computing device. In some embodiments, the scanner **302** may have an

on-board power supply **332**. In other embodiments, the scanner **302** may be powered from a tethered connection to another device, such as a Universal Serial Bus (USB) connection.

As an example of one use of scanner **302**, a reader may scan some text from a newspaper article with scanner **302**. The text is scanned as a bit-mapped image via the scanning head **308**. Logic **326** causes the bit-mapped image to be stored in memory **330** with an associated time-stamp read from the clock unit **328**. Logic **326** may also perform optical character recognition (OCR) or other post-scan processing on the bit-mapped image to convert it to text. Logic **326** may optionally extract a signature from the image, for example by performing a convolution-like process to locate repeating occurrences of characters, symbols or objects, and determine the distance or number of other characters, symbols, or objects between these repeated elements. The reader may then upload the bit-mapped image (or text or other signature, if post-scan processing has been performed by logic **326**) to an associated computer via interface **316**.

As an example of another use of scanner **302**, a reader may capture some text from an article as an audio file by using microphone **310** as an acoustic capture port. Logic **326** causes audio file to be stored in memory **328**. Logic **326** may also perform voice recognition or other post-scan processing on the audio file to convert it to text. As above, the reader may then upload the audio file (or text produced by post-scan processing performed by logic **326**) to an associated computer via interface **316**.

Part II—Overview of the Areas of the Core System

As paper-digital integration becomes more common, there are many aspects of existing technologies that can be changed to take better advantage of this integration, or to enable it to be implemented more effectively. This section highlights some of those issues.

3. Search

Searching a corpus of documents, even so large a corpus as the World Wide Web, has become commonplace for ordinary users, who use a keyboard to construct a search query which is sent to a search engine. This section and the next discuss the aspects of both the construction of a query originated by a capture from a rendered document, and the search engine that handles such a query.

3.1. Scan/Speak/Type as Search Query

Use of the described system typically starts with a few words being captured from a rendered document using any of several methods, including those mentioned in Section 1.2 above. Where the input needs some interpretation to convert it to text, for example in the case of OCR or speech input, there may be end-to-end feedback in the system so that the document corpus can be used to enhance the recognition process. End-to-end feedback can be applied by performing an approximation of the recognition or interpretation, identifying a set of one or more candidate matching documents, and then using information from the possible matches in the candidate documents to further refine or restrict the recognition or interpretation. Candidate documents can be weighted according to their probable relevance (for example, based on then number of other users who have scanned in these documents, or their popularity on the Internet), and these weights can be applied in this iterative recognition process.

3.2. Short Phrase Searching

Because the selective power of a search query based on a few words is greatly enhanced when the relative positions of these words are known, only a small amount of text need be captured for the system to identify the text's location in a

corpus. Most commonly, the input text will be a contiguous sequence of words, such as a short phrase.

3.2.1. Finding Document and Location in Document from Short Capture

In addition to locating the document from which a phrase originates, the system can identify the location in that document and can take action based on this knowledge.

3.2.2. Other Methods of Finding Location

The system may also employ other methods of discovering the document and location, such as by using watermarks or other special markings on the rendered document.

3.3. Incorporation of Other Factors in Search Query

In addition to the captured text, other factors (i.e., information about user identity, profile, and context) may form part of the search query, such as the time of the capture, the identity and geographical location of the user, knowledge of the user's habits and recent activities, etc.

The document identity and other information related to previous captures, especially if they were quite recent, may form part of a search query.

The identity of the user may be determined from a unique identifier associated with a capturing device, and/or biometric or other supplemental information (speech patterns, fingerprints, etc.).

3.4. Knowledge of Nature of Unreliability in Search Query (OCR Errors etc)

The search query can be constructed taking into account the types of errors likely to occur in the particular capture method used. One example of this is an indication of suspected errors in the recognition of specific characters; in this instance a search engine may treat these characters as wildcards, or assign them a lower priority.

3.5. Local Caching of Index for Performance/Offline Use

Sometimes the capturing device may not be in communication with the search engine or corpus at the time of the data capture. For this reason, information helpful to the offline use of the device may be downloaded to the device in advance, or to some entity with which the device can communicate. In some cases, all or a substantial part of an index associated with a corpus may be downloaded. This topic is discussed further in Section 15.3.

3.6. Queries, in Whatever Form, may be Recorded and Acted on Later

If there are likely to be delays or cost associated with communicating a query or receiving the results, this pre-loaded information can improve the performance of the local device, reduce communication costs, and provide helpful and timely user feedback.

In the situation where no communication is available (the local device is "offline"), the queries may be saved and transmitted to the rest of the system at such a time as communication is restored.

In these cases it may be important to transmit a timestamp with each query. The time of the capture can be a significant factor in the interpretation of the query. For example, Section 13.1 discusses the importance of the time of capture in relation to earlier captures. It is important to note that the time of capture will not always be the same as the time that the query is executed.

3.7. Parallel Searching

For performance reasons, multiple queries may be launched in response to a single capture, either in sequence or in parallel. Several queries may be sent in response to a single capture, for example as new words are added to the capture, or to query multiple search engines in parallel.

For example, in some embodiments, the system sends queries to a special index for the current document, to a search

engine on a local machine, to a search engine on the corporate network, and to remote search engines on the Internet.

The results of particular searches may be given higher priority than those from others.

The response to a given query may indicate that other pending queries are superfluous; these may be cancelled before completion.

4. Paper and Search Engines

Often it is desirable for a search engine that handles traditional online queries also to handle those originating from rendered documents. Conventional search engines may be enhanced or modified in a number of ways to make them more suitable for use with the described system.

The search engine and/or other components of the system may create and maintain indices that have different or extra features. The system may modify an incoming paper-originated query or change the way the query is handled in the resulting search, thus distinguishing these paper-originated queries from those coming from queries typed into web browsers and other sources. And the system may take different actions or offer different options when the results are returned by the searches originated from paper as compared to those from other sources. Each of these approaches is discussed below.

4.1. Indexing

Often, the same index can be searched using either paper-originated or traditional queries, but the index may be enhanced for use in the current system in a variety of ways.

4.1.1. Knowledge about the Paper Form

Extra fields can be added to such an index that will help in the case of a paper-based search.

Index Entry Indicating Document Availability in Paper Form

The first example is a field indicating that the document is known to exist or be distributed in paper form. The system may give such documents higher priority if the query comes from paper.

Knowledge of Popularity Paper Form

In this example statistical data concerning the popularity of paper documents (and, optionally, concerning sub-regions within these documents)—for example the amount of scanning activity, circulation numbers provided by the publisher or other sources, etc—is used to give such documents higher priority, to boost the priority of digital counterpart documents (for example, for browser-based queries or web searches), etc.

Knowledge of Rendered Format

Another important example may be recording information about the layout of a specific rendering of a document.

For a particular edition of a book, for example, the index may include information about where the line breaks and page breaks occur, which fonts were used, any unusual capitalization.

The index may also include information about the proximity of other items on the page, such as images, text boxes, tables and advertisements.

Use of Semantic Information in Original

Lastly, semantic information that can be deduced from the source markup but is not apparent in the paper document, such as the fact that a particular piece of text refers to an item offered for sale, or that a certain paragraph contains program code, may also be recorded in the index.

4.1.2. Indexing in the Knowledge of the Capture Method

A second factor that may modify the nature of the index is the knowledge of the type of capture likely to be used. A search initiated by an optical scan may benefit if the index takes into account characters that are easily confused in the OCR process, or includes some knowledge of the fonts used

in the document. Similarly, if the query is from speech recognition, an index based on similar-sounding phonemes may be much more efficiently searched. An additional factor that may affect the use of the index in the described model is the importance of iterative feedback during the recognition process. If the search engine is able to provide feedback from the index as the text is being captured, it can greatly increase the accuracy of the capture.

Indexing Using Offsets

If the index is likely to be searched using the offset-based/ autocorrelation OCR methods described in Section 9, in some embodiments, the system stores the appropriate offset or signature information in an index.

4.1.3. Multiple Indices

Lastly, in the described system, it may be common to conduct searches on many indices. Indices may be maintained on several machines on a corporate network. Partial indices may be downloaded to the capture device, or to a machine close to the capture device. Separate indices may be created for users or groups of users with particular interests, habits or permissions. An index may exist for each filesystem, each directory, even each file on a user's hard disk. Indices are published and subscribed to by users and by systems. It will be important, then, to construct indices that can be distributed, updated, merged and separated efficiently.

4.2. Handling the Queries

4.2.1. Knowing the Capture is from Paper

A search engine may take different actions when it recognizes that a search query originated from a paper document. The engine might handle the query in a way that is more tolerant to the types of errors likely to appear in certain capture methods, for example.

It may be able to deduce this from some indicator included in the query (for example a flag indicating the nature of the capture), or it may deduce this from the query itself (for example, it may recognize errors or uncertainties typical of the OCR process).

Alternatively, queries from a capture device can reach the engine by a different channel or port or type of connection than those from other sources, and can be distinguished in that way. For example, some embodiments of the system will route queries to the search engine by way of a dedicated gateway. Thus, the search engine knows that all queries passing through the dedicated gateway were originated from a paper document.

4.2.2. Use of Context

Section 13 below describes a variety of different factors which are external to the captured text itself, yet which can be a significant aid in identifying a document. These include such things as the history of recent scans, the longer-term reading habits of a particular user, the geographic location of a user and the user's recent use of particular electronic documents. Such factors are referred to herein as "context".

Some of the context may be handled by the search engine itself, and be reflected in the search results. For example, the search engine may keep track of a user's scanning history, and may also cross-reference this scanning history to conventional keyboard-based queries. In such cases, the search engine maintains and uses more state information about each individual user than do most conventional search engines, and each interaction with a search engine may be considered to extend over several searches and a longer period of time than is typical today.

Some of the context may be transmitted to the search engine in the search query (Section 3.3), and may possibly be stored at the engine so as to play a part in future queries. Lastly, some of the context will best be handled elsewhere,

and so becomes a filter or secondary search applied to the results from the search engine.

Data-stream Input to Search

An important input into the search process is the broader context of how the community of users is interacting with the rendered version of the document—for example, which documents are most widely read and by whom. There are analogies with a web search returning the pages that are most frequently linked to, or those that are most frequently selected from past search results. For further discussion of this topic, see Sections 13.4 and 14.2.

4.2.3. Document Sub-regions

The described system can emit and use not only information about documents as a whole, but also information about sub-regions of documents, even down to individual words. Many existing search engines concentrate simply on locating a document or file that is relevant to a particular query. Those that can work on a finer grain and identify a location within a document will provide a significant benefit for the described system.

4.3. Returning the Results

The search engine may use some of the further information it now maintains to affect the results returned.

The system may also return certain documents to which the user has access only as a result of being in possession of the paper copy (Section 7.4).

The search engine may also offer new actions or options appropriate to the described system, beyond simple retrieval of the text.

5. Markup, Annotations and Metadata

In addition to performing the capture-search-retrieve process, the described system also associates extra functionality with a document, and in particular with specific locations or segments of text within a document. This extra functionality is often, though not exclusively, associated with the rendered document by being associated with its electronic counterpart. As an example, hyperlinks in a web page could have the same functionality when a printout of that web page is scanned. In some cases, the functionality is not defined in the electronic document, but is stored or generated elsewhere.

This layer of added functionality is referred to herein as "markup".

5.1. Overlays, Static and Dynamic

One way to think of the markup is as an "overlay" on the document, which provides further information about—and may specify actions associated with—the document or some portion of it. The markup may include human-readable content, but is often invisible to a user and/or intended for machine use. Examples include options to be displayed in a popup-menu on a nearby display when a user captures text from a particular area in a rendered document, or audio samples that illustrate the pronunciation of a particular phrase.

5.1.1. Several Layers, Possibly from Several Sources

Any document may have multiple overlays simultaneously, and these may be sourced from a variety of locations. Markup data may be created or supplied by the author of the document, or by the user, or by some other party.

Markup data may be attached to the electronic document or embedded in it. It may be found in a conventional location (for example, in the same place as the document but with a different filename suffix). Markup data may be included in the search results of the query that located the original document, or may be found by a separate query to the same or another search engine. Markup data may be found using the original captured text and other capture information or contextual information, or it may be found using already-deduced infor-

mation about the document and location of the capture. Markup data may be found in a location specified in the document, even if the markup itself is not included in the document.

The markup may be largely static and specific to the document, similar to the way links on a traditional html web page are often embedded as static data within the html document, but markup may also be dynamically generated and/or applied to a large number of documents. An example of dynamic markup is information attached to a document that includes the up-to-date share price of companies mentioned in that document. An example of broadly applied markup is translation information that is automatically available on multiple documents or sections of documents in a particular language.

5.1.2. Personal "Plug-in" Layers

Users may also install, or subscribe to particular sources of, markup data, thus personalizing the system's response to particular captures.

5.2. Keywords and Phrases, Trademarks and Logos

Some elements in documents may have particular "markup" or functionality associated with them based on their own characteristics rather than their location in a particular document. Examples include special marks that are printed in the document purely for the purpose of being scanned, as well as logos and trademarks that can link the user to further information about the organization concerned. The same applies to "keywords" or "key phrases" in the text. Organizations might register particular phrases with which they are associated, or with which they would like to be associated, and attach certain markup to them that would be available wherever that phrase was scanned.

Any word, phrase, etc. may have associated markup. For example, the system may add certain items to a pop-up menu (e.g., a link to an online bookstore) whenever the user captures the word "book," or the title of a book, or a topic related to books. In some embodiments, of the system, digital counterpart documents or indices are consulted to determine whether a capture occurred near the word "book," or the title of a book, or a topic related to books—and the system behavior is modified in accordance with this proximity to keyword elements. In the preceding example, note that markup enables data captured from non-commercial text or documents to trigger a commercial transaction.

5.3. User-supplied Content

5.3.1. User Comments and Annotations, Including Multimedia

Annotations are another type of electronic information that may be associated with a document. For example, a user can attach an audio file of his/her thoughts about a particular document for later retrieval as voice annotations. As another example of a multimedia annotation, a user may attach photographs of places referred to in the document. The user generally supplies annotations for the document but the system can associate annotations from other sources (for example, other users in a work group may share annotations).

5.3.2. Notes from Proof-reading

An important example of user-sourced markup is the annotation of paper documents as part of a proofreading, editing or reviewing process.

5.4. Third-party Content

As mentioned earlier, markup data may often be supplied by third parties, such as by other readers of the document. Online discussions and reviews are a good example, as are community-managed information relating to particular works, volunteer-contributed translations and explanations.

Another example of third-party markup is that provided by advertisers.

5.5. Dynamic Markup Based on Other Users' Data Streams

By analyzing the data captured from documents by several or all users of the system, markup can be generated based on the activities and interests of a community. An example might be an online bookstore that creates markup or annotations that tell the user, in effect, "People who enjoyed this book also enjoyed . . .". The markup may be less anonymous, and may tell the user which of the people in his/her contact list have also read this document recently. Other examples of data-stream analysis are included in Section 14.

5.6. Markup Based on External Events and Data Sources

Markup will often be based on external events and data sources, such as input from a corporate database, information from the public Internet, or statistics gathered by the local operating system.

Data sources may also be more local, and in particular may provide information about the user's context—his/her identity, location and activities. For example, the system might communicate with the user's mobile phone and offer a markup layer that gives the user the option to send a document to somebody that the user has recently spoken to on the phone.

6. Authentication, Personalization and Security

In many situations, the identity of the user will be known. Sometimes this will be an "anonymous identity", where the user is identified only by the serial number of the capture device, for example. Typically, however, it is expected that the system will have a much more detailed knowledge of the user, which can be used for personalizing the system and to allow activities and transactions to be performed in the user's name.

6.1. User History and "Life Library"

One of the simplest and yet most useful functions that the system can perform is to keep a record for a user of the text that s/he has captured and any further information related to that capture, including the details of any documents found, the location within that document and any actions taken as a result.

This stored history is beneficial for both the user and the system.

6.1.1. For the User

The user can be presented with a "Life Library", a record of everything s/he has read and captured. This may be simply for personal interest, but may be used, for example, in a library by an academic who is gathering material for the bibliography of his next paper.

In some circumstances, the user may wish to make the library public, such as by publishing it on the web in a similar manner to a weblog, so that others may see what s/he is reading and finds of interest.

Lastly, in situations where the user captures some text and the system cannot immediately act upon the capture (for example, because an electronic version of the document is not yet available) the capture can be stored in the library and can be processed later, either automatically or in response to a user request. A user can also subscribe to new markup services and apply them to previously captured scans.

6.1.2. For the System

A record of a user's past captures is also useful for the system. Many aspects of the system operation can be enhanced by knowing the user's reading habits and history. The simplest example is that any scan made by a user is more likely to come from a document that the user has scanned in the recent past, and in particular if the previous scan was within the last few minutes it is very likely to be from the same document. Similarly, it is more likely that a document is being read in start-to-finish order. Thus, for English documents, it is

also more likely that later scans will occur farther down in the document. Such factors can help the system establish the location of the capture in cases of ambiguity, and can also reduce the amount of text that needs to be captured.

6.2. Scanner as Payment, Identity and Authentication Device

Because the capture process generally begins with a device of some sort, typically an optical scanner or voice recorder, this device may be used as a key that identifies the user and authorizes certain actions.

6.2.1. Associate Scanner with Phone or other Account

The device may be embedded in a mobile phone or in some other way associated with a mobile phone account. For example, a scanner may be associated with a mobile phone account by inserting a SIM card associated with the account into the scanner. Similarly, the device may be embedded in a credit card or other payment card, or have the facility for such a card to be connected to it. The device may therefore be used as a payment token, and financial transactions may be initiated by the capture from the rendered document.

6.2.2. Using Scanner Input for Authentication

The scanner may also be associated with a particular user or account through the process of scanning some token, symbol or text associated with that user or account. In addition, scanner may be used for biometric identification, for example by scanning the fingerprint of the user. In the case of an audio-based capture device, the system may identify the user by matching the voice pattern of the user or by requiring the user to speak a certain password or phrase.

For example, where a user scans a quote from a book and is offered the option to buy the book from an online retailer, the user can select this option, and is then prompted to scan his/her fingerprint to confirm the transaction.

See also Sections 15.5 and 15.6.

6.2.3. Secure Scanning Device

When the capture device is used to identify and authenticate the user, and to initiate transactions on behalf of the user, it is important that communications between the device and other parts of the system are secure. It is also important to guard against such situations as another device impersonating a scanner, and so-called “man in the middle” attacks where communications between the device and other components are intercepted.

Techniques for providing such security are well understood in the art; in various embodiments, the hardware and software in the device and elsewhere in the system are configured to implement such techniques.

7. Publishing Models and Elements

An advantage of the described system is that there is no need to alter the traditional processes of creating, printing or publishing documents in order to gain many of the system’s benefits. There are reasons, though, that the creators or publishers of a document—hereafter simply referred to as the “publishers”—may wish to create functionality to support the described system.

This section is primarily concerned with the published documents themselves. For information about other related commercial transactions, such as advertising, see Section 10 entitled “P-Commerce”.

7.1. Electronic Companions to Printed Documents

The system allows for printed documents to have an associated electronic presence. Conventionally publishers often ship a CD-ROM with a book that contains further digital information, tutorial movies and other multimedia data, sample code or documents, or further reference materials. In addition, some publishers maintain web sites associated with particular publications which provide such materials, as well

as information which may be updated after the time of publishing, such as errata, further comments, updated reference materials, bibliographies and further sources of relevant data, and translations into other languages. Online forums allow readers to contribute their comments about the publication.

The described system allows such materials to be much more closely tied to the rendered document than ever before, and allows the discovery of and interaction with them to be much easier for the user. By capturing a portion of text from the document, the system can automatically connect the user to digital materials associated with the document, and more particularly associated with that specific part of the document. Similarly, the user can be connected to online communities that discuss that section of the text, or to annotations and commentaries by other readers. In the past, such information would typically need to be found by searching for a particular page number or chapter.

An example application of this is in the area of academic textbooks (Section 17.5).

7.2. “Subscriptions” to Printed Documents

Some publishers may have mailing lists to which readers can subscribe if they wish to be notified of new relevant matter or when a new edition of the book is published. With the described system, the user can register an interest in particular documents or parts of documents more easily, in some cases even before the publisher has considered providing any such functionality. The reader’s interest can be fed to the publisher, possibly affecting their decision about when and where to provide updates, further information, new editions or even completely new publications on topics that have proved to be of interest in existing books.

7.3. Printed Marks with Special Meaning or Containing Special Data

Many aspects of the system are enabled simply through the use of the text already existing in a document. If the document is produced in the knowledge that it may be used in conjunction with the system, however, extra functionality can be added by printing extra information in the form of special marks, which may be used to identify the text or a required action more closely, or otherwise enhance the document’s interaction with the system. The simplest and most important example is an indication to the reader that the document is definitely accessible through the system. A special icon might be used, for example, to indicate that this document has an online discussion forum associated with it.

Such symbols may be intended purely for the reader, or they may be recognized by the system when scanned and used to initiate some action. Sufficient data may be encoded in the symbol to identify more than just the symbol: it may also store information, for example about the document, edition, and location of the symbol, which could be recognized and read by the system.

7.4. Authorization Through Possession of the Paper Document

There are some situations where possession of or access to the printed document would entitle the user to certain privileges, for example, the access to an electronic copy of the document or to additional materials. With the described system, such privileges could be granted simply as a result of the user capturing portions of text from the document, or scanning specially printed symbols. In cases where the system needed to ensure that the user was in possession of the entire document, it might prompt the user to scan particular items or phrases from particular pages, e.g. “the second line of page 46”.

7.5. Documents which Expire

If the printed document is a gateway to extra materials and functionality, access to such features can also be time-limited. After the expiry date, a user may be required to pay a fee or obtain a newer version of the document to access the features again. The paper document will, of course, still be usable, but will lose some of its enhanced electronic functionality. This may be desirable, for example, because there is profit for the publisher in receiving fees for access to electronic materials, or in requiring the user to purchase new editions from time to time, or because there are disadvantages associated with outdated versions of the printed document remaining in circulation. Coupons are an example of a type of commercial document that can have an expiration date.

7.6. Popularity Analysis and Publishing Decisions

Section 10.5 discusses the use of the system's statistics to influence compensation of authors and pricing of advertisements.

In some embodiments, the system deduces the popularity of a publication from the activity in the electronic community associated with it as well as from the use of the paper document. These factors may help publishers to make decisions about what they will publish in future. If a chapter in an existing book, for example, turns out to be exceedingly popular, it may be worth expanding into a separate publication.

8. Document Access Services

An important aspect of the described system is the ability to provide to a user who has access to a rendered copy of a document access to an electronic version of that document. In some cases, a document is freely available on a public network or a private network to which the user has access. The system uses the captured text to identify, locate and retrieve the document, in some cases displaying it on the user's screen or depositing it in their email inbox.

In some cases, a document will be available in electronic form, but for a variety of reasons may not be accessible to the user. There may not be sufficient connectivity to retrieve the document, the user may not be entitled to retrieve it, there may be a cost associated with gaining access to it, or the document may have been withdrawn and possibly replaced by a new version, to name just a few possibilities. The system typically provides feedback to the user about these situations.

As mentioned in Section 7.4, the degree or nature of the access granted to a particular user may be different if it is known that the user already has access to a printed copy of the document.

8.1. Authenticated Document Access

Access to the document may be restricted to specific users, or to those meeting particular criteria, or may only be available in certain circumstances, for example when the user is connected to a secure network. Section 6 describes some of the ways in which the credentials of a user and scanner may be established.

8.2. Document Purchase—Copyright-owner Compensation

Documents that are not freely available to the general public may still be accessible on payment of a fee, often as compensation to the publisher or copyright-holder. The system may implement payment facilities directly or may make use of other payment methods associated with the user, including those described in Section 6.2.

8.3. Document Escrow and Proactive Retrieval

Electronic documents are often transient; the digital source version of a rendered document may be available now but inaccessible in future. The system may retrieve and store the existing version on behalf of the user, even if the user has not requested it, thus guaranteeing its availability should the user

request it in future. This also makes it available for the system's use, for example for searching as part of the process of identifying future captures.

In the event that payment is required for access to the document, a trusted "document escrow" service can retrieve the document on behalf of the user, such as upon payment of a modest fee, with the assurance that the copyright holder will be fully compensated in future if the user should ever request the document from the service.

Variations on this theme can be implemented if the document is not available in electronic form at the time of capture. The user can authorize the service to submit a request for or make a payment for the document on his/her behalf if the electronic document should become available at a later date.

8.4. Association with Other Subscriptions and Accounts

Sometimes payment may be waived, reduced or satisfied based on the user's existing association with another account or subscription. Subscribers to the printed version of a newspaper might automatically be entitled to retrieve the electronic version, for example.

In other cases, the association may not be quite so direct: a user may be granted access based on an account established by their employer, or based on their scanning of a printed copy owned by a friend who is a subscriber.

8.5. Replacing Photocopying with Scan-and-print

The process of capturing text from a paper document, identifying an electronic original, and printing that original, or some portion of that original associated with the capture, forms an alternative to traditional photocopying with many advantages:

- the paper document need not be in the same location as the final printout, and in any case need not be there at the same time

- the wear and damage caused to documents by the photocopying process, especially to old, fragile and valuable documents, can be avoided

- the quality of the copy is typically be much higher
- records may be kept about which documents or portions of documents are the most frequently copied

- payment may be made to the copyright owner as part of the process
- unauthorized copying may be prohibited

8.6. Locating Valuable Originals from Photocopies

When documents are particularly valuable, as in the case of legal instruments or documents that have historical or other particular significance, people may typically work from copies of those documents, often for many years, while the originals are kept in a safe location.

The described system could be coupled to a database which records the location of an original document, for example in an archiving warehouse, making it easy for somebody with access to a copy to locate the archived original paper document.

9. Text Recognition Technologies

Optical Character Recognition (OCR) technologies have traditionally focused on images that include a large amount of text, for example from a flat-bed scanner capturing a whole page. OCR technologies often need substantial training and correcting by the user to produce useful text. OCR technologies often require substantial processing power on the machine doing the OCR, and, while many systems use a dictionary, they are generally expected to operate on an effectively infinite vocabulary.

All of the above traditional characteristics may be improved upon in the described system.

While this section focuses on OCR, many of the issues discussed map directly onto other recognition technologies,

in particular speech recognition. As mentioned in Section 3.1, the process of capturing from paper may be achieved by a user reading the text aloud into a device which captures audio. Those skilled in the art will appreciate that principles discussed here with respect to images, fonts, and text fragments often also apply to audio samples, user speech models and phonemes.

9.1. Optimization for Appropriate Devices

A scanning device for use with the described system will often be small, portable, and low power. The scanning device may capture only a few words at a time, and in some implementations does not even capture a whole character at once, but rather a horizontal slice through the text, many such slices being stitched together to form a recognizable signal from which the text may be deduced. The scanning device may also have very limited processing power or storage so, while in some embodiments it may perform all of the OCR process itself, many embodiments will depend on a connection to a more powerful device, possibly at a later time, to convert the captured signals into text. Lastly, it may have very limited facilities for user interaction, so may need to defer any requests for user input until later, or operate in a “best-guess” mode to a greater degree than is common now.

9.2. “Uncertain” OCR

The primary new characteristic of OCR within the described system is the fact that it will, in general, examine images of text which exists elsewhere and which may be retrieved in digital form. An exact transcription of the text is therefore not always required from the OCR engine. The OCR system may output a set or a matrix of possible matches, in some cases including probability weightings, which can still be used to search for the digital original.

9.3. Iterative OCR—Guess, Disambiguate, Guess . . .

If the device performing the recognition is able to contact the document index at the time of processing, then the OCR process can be informed by the contents of the document corpus as it progresses, potentially offering substantially greater recognition accuracy.

Such a connection will also allow the device to inform the user when sufficient text has been captured to identify the digital source.

9.4. Using Knowledge of Likely Rendering

When the system has knowledge of aspects of the likely printed rendering of a document—such as the font typeface used in printing, or the layout of the page, or which sections are in italics—this too can help in the recognition process. (Section 4.1.1)

9.5. Font Caching—Determine Font on Host, Download to Client

As candidate source texts in the document corpus are identified, the font, or a rendering of it, may be downloaded to the device to help with the recognition.

9.6. Autocorrelation and Character Offsets

While component characters of a text fragment may be the most recognized way to represent a fragment of text that may be used as a document signature, other representations of the text may work sufficiently well that the actual text of a text fragment need not be used when attempting to locate the text fragment in a digital document and/or database, or when disambiguating the representation of a text fragment into a readable form. Other representations of text fragments may provide benefits that actual text representations lack. For example, optical character recognition of text fragments is often prone to errors, unlike other representations of captured text fragments that may be used to search for and/or recreate a text fragment without resorting to optical character recog-

inition for the entire fragment. Such methods may be more appropriate for some devices used with the current system.

Those of ordinary skill in the art and others will appreciate that there are many ways of describing the appearance of text fragments. Such characterizations of text fragments may include, but are not limited to, word lengths, relative word lengths, character heights, character widths, character shapes, character frequencies, token frequencies, and the like. In some embodiments, the offsets between matching text tokens (i.e., the number of intervening tokens plus one) are used to characterize fragments of text.

Conventional OCR uses knowledge about fonts, letter structure and shape to attempt to determine characters in scanned text. Embodiments of the present invention are different; they employ a variety of methods that use the rendered text itself to assist in the recognition process. These embodiments use characters (or tokens) to “recognize each other.” One way to refer to such self-recognition is “template matching,” and is similar to “convolution.” To perform such self-recognition, the system slides a copy of the text horizontally over itself and notes matching regions of the text images. Prior template matching and convolution techniques encompass a variety of related techniques. These techniques to tokenize and/or recognize characters/tokens will be collectively referred to herein as “autocorrelation,” as the text is used to correlate with its own component parts when matching characters/tokens.

When autocorrelating, complete connected regions that match are of interest. This occurs when characters (or groups of characters) overlay other instances of the same character (or group). Complete connected regions that match automatically provide tokenizing of the text into component tokens. As the two copies of the text are slid past each other, the regions where perfect matching occurs (i.e., all pixels in a vertical slice are matched) are noted. When a character/token matches itself, the horizontal extent of this matching (e.g., the connected matching portion of the text) also matches.

Note that at this stage there is no need to determine the actual identity of each token (i.e., the particular letter, digit or symbol, or group of these, that corresponds to the token image), only the offset to the next occurrence of the same token in the scanned text. The offset number is the distance (number of tokens) to the next occurrence of the same token. If the token is unique within the text string, the offset is zero (0). The sequence of token offsets thus generated is a signature that can be used to identify the scanned text.

In some embodiments, the token offsets determined for a string of scanned tokens are compared to an index that indexes a corpus of electronic documents based upon the token offsets of their contents (Section 4.1.2). In other embodiments, the token offsets determined for a string of scanned tokens are converted to text, and compared to a more conventional index that indexes a corpus of electronic documents based upon their contents

As has been noted earlier, a similar token-correlation process may be applied to speech fragments when the capture process consists of audio samples of spoken words.

9.7. Font/character “Self-recognition”

Conventional template-matching OCR compares scanned images to a library of character images. In essence, the alphabet is stored for each font and newly scanned images are compared to the stored images to find matching characters. The process generally has an initial delay until the correct font has been identified. After that, the OCR process is relatively quick because most documents use the same font throughout. Subsequent images can therefore be converted to text by comparison with the most recently identified font library.

The shapes of characters in most commonly used fonts are related. For example, in most fonts, the letter “c” and the letter “e” are visually related—as are “t” and “f”, etc. The OCR process is enhanced by use of this relationship to construct templates for letters that have not been scanned yet. For example, where a reader scans a short string of text from a paper document in a previously unencountered font such that the system does not have a set of image templates with which to compare the scanned images the system can leverage the probable relationship between certain characters to construct the font template library even though it has not yet encountered all of the letters in the alphabet. The system can then use the constructed font template library to recognize subsequent scanned text and to further refine the constructed font library.

9.8. Send Anything Unrecognized (Including Graphics) to Server

When images cannot be machine-transcribed into a form suitable for use in a search process, the images themselves can be saved for later use by the user, for possible manual transcription, or for processing at a later date when different resources may be available to the system.

10. P-Commerce

Many of the actions made possible by the system result in some commercial transaction taking place. The phrase p-commerce is used herein to describe commercial activities initiated from paper via the system.

10.1. Sales of Documents from their Physical Printed Copies.

When a user captures text from a document, the user may be offered that document for purchase either in paper or electronic form. The user may also be offered related documents, such as those quoted or otherwise referred to in the paper document, or those on a similar subject, or those by the same author.

10.2. Sales of Anything Else Initiated or Aided by Paper

The capture of text may be linked to other commercial activities in a variety of ways. The captured text may be in a catalog that is explicitly designed to sell items, in which case the text will be associated fairly directly with the purchase of an item (Section 18.2). The text may also be part of an advertisement, in which case a sale of the item being advertised may ensue.

In other cases, the user captures other text from which their potential interest in a commercial transaction may be deduced. A reader of a novel set in a particular country, for example, might be interested in a holiday there. Someone reading a review of a new car might be considering purchasing it. The user may capture a particular fragment of text knowing that some commercial opportunity will be presented to them as a result, or it may be a side-effect of their capture activities.

10.3. Capture of Labels, Icons, Serial Numbers, Barcodes on an Item Resulting in a Sale

Sometimes text or symbols are actually printed on an item or its packaging. An example is the serial number or product id often found on a label on the back or underside of a piece of electronic equipment. The system can offer the user a convenient way to purchase one or more of the same items by capturing that text. They may also be offered manuals, support or repair services.

10.4. Contextual Advertisements

In addition to the direct capture of text from an advertisement, the system allows for a new kind of advertising which is not necessarily explicitly in the rendered document, but is nonetheless based on what people are reading.

10.4.1. Advertising Based on Scan Context and History

In a traditional paper publication, advertisements generally consume a large amount of space relative to the text of a newspaper article, and a limited number of them can be placed around a particular article. In the described system, advertising can be associated with individual words or phrases, and can be selected according to the particular interest the user has shown by capturing that text and possibly taking into account their history of past scans.

With the described system, it is possible for a purchase to be tied to a particular printed document and for an advertiser to get significantly more feedback about the effectiveness of their advertising in particular print publications.

10.4.2. Advertising Based on User Context and History

The system may gather a large amount of information about other aspects of a user’s context for its own use (Section 13); estimates of the geographical location of the user are a good example. Such data can also be used to tailor the advertising presented to a user of the system.

10.5. Models of Compensation

The system enables some new models of compensation for advertisers and marketers. The publisher of a printed document containing advertisements may receive some income from a purchase that originated from their document. This may be true whether or not the advertisement existed in the original printed form; it may have been added electronically either by the publisher, the advertiser or some third party, and the sources of such advertising may have been subscribed to by the user.

10.5.1. Popularity-based Compensation

Analysis of the statistics generated by the system can reveal the popularity of certain parts of a publication (Section 14.2). In a newspaper, for example, it might reveal the amount of time readers spend looking at a particular page or article, or the popularity of a particular columnist. In some circumstances, it may be appropriate for an author or publisher to receive compensation based on the activities of the readers rather than on more traditional metrics such as words written or number of copies distributed. An author whose work becomes a frequently read authority on a subject might be considered differently in future contracts from one whose books have sold the same number of copies but are rarely opened. (See also Section 7.6)

10.5.2. Popularity-Based Advertising

Decisions about advertising in a document may also be based on statistics about the readership. The advertising space around the most popular columnists may be sold at a premium rate. Advertisers might even be charged or compensated some time after the document is published based on knowledge about how it was received.

10.6. Marketing Based on Life Library

The “Life Library” or scan history described in Sections 6.1 and 16.1 can be an extremely valuable source of information about the interests and habits of a user. Subject to the appropriate consent and privacy issues, such data can inform offers of goods or services to the user. Even in an anonymous form, the statistics gathered can be exceedingly useful.

10.7. Sale/information at Later Date (When Available)

Advertising and other opportunities for commercial transactions may not be presented to the user immediately at the time of text capture. For example, the opportunity to purchase a sequel to a novel may not be available at the time the user is reading the novel, but the system may present them with that opportunity when the sequel is published.

A user may capture data that relates to a purchase or other commercial transaction, but may choose not to initiate and/or complete the transaction at the time the capture is made. In

some embodiments, data related to captures is stored in a user's Life Library, and these Life Library entries can remain "active" (i.e., capable of subsequent interactions similar to those available at the time the capture was made). Thus a user may review a capture at some later time, and optionally complete a transaction based on that capture. Because the system can keep track of when and where the original capture occurred, all parties involved in the transaction can be properly compensated. For example, the author who wrote the story—and the publisher who published the story—that appeared next to the advertisement from which the user captured data can be compensated when, six months later, the user visits their Life Library, selects that particular capture from the history, and chooses "Purchase this item at Amazon" from the pop-up menu (which can be similar or identical to the menu optionally presented at the time of the capture).

11. Operating System and Application Integration

Modern Operating Systems (OSs) and other software packages have many characteristics that can be advantageously exploited for use with the described system, and may also be modified in various ways to provide an even better platform for its use.

11.1. Incorporation of Scan and Print-related Information in Metadata and Indexing

New and upcoming file systems and their associated databases often have the ability to store a variety of metadata associated with each file. Traditionally, this metadata has included such things as the ID of the user who created the file, the dates of creation, last modification, and last use. Newer file systems allow such extra information as keywords, image characteristics, document sources and user comments to be stored, and in some systems this metadata can be arbitrarily extended. File systems can therefore be used to store information that would be useful in implementing the current system. For example, the date when a given document was last printed can be stored by the file system, as can details about which text from it has been captured from paper using the described system, and when and by whom.

Operating systems are also starting to incorporate search engine facilities that allow users to find local files more easily. These facilities can be advantageously used by the system. It means that many of the search-related concepts discussed in Sections 3 and 4 apply not just to today's Internet-based and similar search engines, but also to every personal computer.

In some cases specific software applications will also include support for the system above and beyond the facilities provided by the OS.

11.2. OS Support for Capture Devices

As the use of capture devices such as pen scanners becomes increasingly common, it will become desirable to build support for them into the operating system, in much the same way as support is provided for mice and printers, since the applicability of capture devices extends beyond a single software application. The same will be true for other aspects of the system's operation. Some examples are discussed below. In some embodiments, the entire described system, or the core of it, is provided by the OS. In some embodiments, support for the system is provided by Application Programming Interfaces (APIs) that can be used by other software packages, including those directly implementing aspects of the system.

11.2.1. Support for OCR and Other Recognition Technologies

Most of the methods of capturing text from a rendered document require some recognition software to interpret the source data, typically a scanned image or some spoken words, as text suitable for use in the system. Some OSs include support for speech or handwriting recognition, though it is

less common for OSs to include support for OCR, since in the past the use of OCR has typically been limited to a small range of applications.

As recognition components become part of the OS, they can take better advantage of other facilities provided by the OS. Many systems include spelling dictionaries, grammar analysis tools, internationalization and localization facilities, for example, all of which can be advantageously employed by the described system for its recognition process, especially since they may have been customized for the particular user to include words and phrases that he/she would commonly encounter.

If the operating system includes full-text indexing facilities, then these can also be used to inform the recognition process, as described in Section 9.3.

11.2.2. Action to be Taken on Scans

If an optical scan or other capture occurs and is presented to the OS, it may have a default action to be taken under those circumstances in the event that no other subsystem claims ownership of the capture. An example of a default action is presenting the user with a choice of alternatives, or submitting the captured text to the OS's built-in search facilities.

11.2.3. OS has Default Action for Particular Documents or Document Types

If the digital source of the rendered document is found, the OS may have a standard action that it will take when that particular document, or a document of that class, is scanned. Applications and other subsystems may register with the OS as potential handlers of particular types of capture, in a similar manner to the announcement by applications of their ability to handle certain file types.

Markup data associated with a rendered document, or with a capture from a document, can include instructions to the operating system to launch specific applications, pass applications arguments, parameters, or data, etc.

11.2.4. Interpretation of Gestures and Mapping into Standard Actions

In Section 12.1.3 the use of "gestures" is discussed, particularly in the case of optical scanning, where particular movements made with a handheld scanner might represent standard actions such as marking the start and end of a region of text.

This is analogous to actions such as pressing the shift key on a keyboard while using the cursor keys to select a region of text, or using the wheel on a mouse to scroll a document. Such actions by the user are sufficiently standard that they are interpreted in a system-wide way by the OS, thus ensuring consistent behavior. The same is desirable for scanner gestures and other scanner-related actions.

11.2.5. Set Response to Standard (and Non-standard) Iconic/text Printed Menu Items

In a similar way, certain items of text or other symbols may, when scanned, cause standard actions to occur, and the OS may provide a selection of these. An example might be that scanning the text "[print]" in any document would cause the OS to retrieve and print a copy of that document. The OS may also provide a way to register such actions and associate them with particular scans.

11.3. Support in System GUI Components for Typical Scan-initiated Activities

Most software applications are based substantially on standard Graphical User Interface components provided by the OS.

Use of these components by developers helps to ensure consistent behavior across multiple packages, for example that pressing the left-cursor key in any text-editing context

should move the cursor to the left, without every programmer having to implement the same functionality independently.

A similar consistency in these components is desirable when the activities are initiated by text-capture or other aspects of the described system. Some examples are given below.

11.3.1. Interface to Find Particular Text Content

A typical use of the system may be for the user to scan an area of a paper document, and for the system to open the electronic counterpart in a software package that is able to display or edit it, and cause that package to scroll to and highlight the scanned text (Section 12.2.1). The first part of this process, finding and opening the electronic document, is typically provided by the S and is standard across software packages. The second part, however—locating a particular piece of text within a document and causing the package to scroll to it and highlight it—is not yet standardized and is often implemented differently by each package. The availability of a standard API for this functionality could greatly enhance the operation of this aspect of the system.

11.3.2. Text Interactions

Once a piece of text has been located within a document, the system may wish to perform a variety of operations upon that text. As an example, the system may request the surrounding text, so that the user's capture of a few words could result in the system accessing the entire sentence or paragraph containing them. Again, this functionality can be usefully provided by the OS rather than being implemented in every piece of software that handles text.

11.3.3. Contextual (Popup) Menus

Some of the operations that are enabled by the system will require user feedback, and this may be optimally requested within the context of the application handling the data. In some embodiments, the system uses the application pop-up menus traditionally associated with clicking the right mouse button on some text. The system inserts extra options into such menus, and causes them to be displayed as a result of activities such as scanning a paper document.

11.4. Web/network Interfaces

In today's increasingly networked world, much of the functionality available on individual machines can also be accessed over a network, and the functionality associated with the described system is no exception. As an example, in an office environment, many paper documents received by a user may have been printed by other users' machines on the same corporate network. The system on one computer, in response to a capture, may be able to query those other machines for documents which may correspond to that capture, subject to the appropriate permission controls.

11.5. Printing of Document Causes Saving

An important factor in the integration of paper and digital documents is maintaining as much information as possible about the transitions between the two. In some embodiments, the OS keeps a simple record of when any document was printed and by whom. In some embodiments, the OS takes one or more further actions that would make it better suited for use with the system.

Examples include:

Saving the digital rendered version of every document printed along with information about the source from which it was printed

Saving a subset of useful information about the printed version—for example, the fonts used and where the line breaks occur—which might aid future scan interpretation

Saving the version of the source document associated with any printed copy

Indexing the document automatically at the time of printing and storing the results for future searching

11.6. My (Printed/Scanned) Documents

An OS often maintains certain categories of folders or files that have particular significance. A user's documents may, by convention or design, be found in a "My Documents" folder, for example. Standard file-opening dialogs may automatically include a list of recently opened documents.

On an OS optimized for use with the described system, such categories may be enhanced or augmented in ways that take into account a user's interaction with paper versions of the stored files. Categories such as "My Printed Documents" or "My Recently-Read Documents" might usefully be identified and incorporated in its operations.

11.7. OS-level Markup Hierarchies

Since important aspects of the system are typically provided using the "markup" concepts discussed in Section 5, it would clearly be advantageous to have support for such markup provided by the OS in a way that was accessible to multiple applications as well as to the OS itself. In addition, layers of markup may be provided by the OS, based on its own knowledge of documents under its control and the facilities it is able to provide.

11.8. Use of OS DRM Facilities

An increasing number of operating systems support some form of "Digital Rights Management": the ability to control the use of particular data according to the rights granted to a particular user, software entity or machine. It may inhibit unauthorized copying or distribution of a particular document, for example.

12. User Interface

The user interface of the system may be entirely on a PC, if the capture device is relatively dumb and is connected to it by a cable, or entirely on the device, if it is sophisticated and with significant processing power of its own. In some cases, some functionality resides in each component. Part, or indeed all, of the system's functionality may also be implemented on other devices such as mobile phones or PDAs.

The descriptions in the following sections are therefore indications of what may be desirable in certain implementations, but they are not necessarily appropriate for all and may be modified in several ways.

12.1. On the Capture Device

With all capture devices, but particularly in the case of an optical scanner, the user's attention will generally be on the device and the paper at the time of scanning. It is very desirable, then, that any input and feedback needed as part of the process of scanning do not require the user's attention to be elsewhere, for example on the screen of a computer, more than is necessary.

12.1.1. Feedback on Scanner

A handheld scanner may have a variety of ways of providing feedback to the user about particular conditions. The most obvious types are direct visual, where the scanner incorporates indicator lights or even a full display, and auditory, where the scanner can make beeps, clicks or other sounds. Important alternatives include tactile feedback, where the scanner can vibrate, buzz, or otherwise stimulate the user's sense of touch, and projected feedback, where it indicates a status by projecting onto the paper anything from a colored spot of light to a sophisticated display.

Important immediate feedback that may be provided on the device includes:

feedback on the scanning process—user scanning too fast, at too great an angle, or drifting too high or low on a particular line

sufficient content—enough has been scanned to be pretty certain of finding a match if one exists—important for disconnected operation

context known—a source of the text has been located
unique context known—one unique source of the text has been located

availability of content—indication of whether the content is freely available to the user, or at a cost

Many of the user interactions normally associated with the later stages of the system may also take place on the capture device if it has sufficient abilities, for example, to display part or all of a document.

12.1.2. Controls on Scanner

The device may provide a variety of ways for the user to provide input in addition to basic text capture. Even when the device is in close association with a host machine that has input options such as keyboards and mice, it can be disruptive for the user to switch back and forth between manipulating the scanner and using a mouse, for example.

The handheld scanner may have buttons, scroll/jog-wheels, touch-sensitive surfaces, and/or accelerometers for detecting the movement of the device. Some of these allow a richer set of interactions while still holding the scanner.

For example, in response to scanning some text, the system presents the user with a set of several possible matching documents. The user uses a scroll-wheel on the side of the scanner is to select one from the list, and clicks a button to confirm the selection.

12.1.3. Gestures

The primary reason for moving a scanner across the paper is to capture text, but some movements may be detected by the device and used to indicate other user intentions. Such movements are referred to herein as “gestures”.

As an example, the user can indicate a large region of text by scanning the first few words in conventional left-to-right order, and the last few in reverse order, i.e. right to left. The user can also indicate the vertical extent of the text of interest by moving the scanner down the page over several lines. A backwards scan might indicate cancellation of the previous scan operation.

12.1.4. Online/Offline Behavior

Many aspects of the system may depend on network connectivity, either between components of the system such as a scanner and a host laptop, or with the outside world in the form of a connection to corporate databases and Internet search. This connectivity may not be present all the time, however, and so there will be occasions when part or all of the system may be considered to be “offline”. It is desirable to allow the system to continue to function usefully in those circumstances.

The device may be used to capture text when it is out of contact with other parts of the system. A very simple device may simply be able to store the image or audio data associated with the capture, ideally with a timestamp indicating when it was captured. The various captures may be uploaded to the rest of the system when the device is next in contact with it, and handled then. The device may also upload other data associated with the captures, for example voice annotations associated with optical scans, or location information.

More sophisticated devices may be able to perform some or all of the system operations themselves despite being disconnected. Various techniques for improving their ability to do so are discussed in Section 15.3. Often it will be the case that some, but not all, of the desired actions can be performed while offline. For example, the text may be recognized, but identification of the source may depend on a connection to an Internet-based search engine. In some embodiments, the

device therefore stores sufficient information about how far each operation has progressed for the rest of the system to proceed efficiently when connectivity is restored.

The operation of the system will, in general, benefit from immediately available connectivity, but there are some situations in which performing several captures and then processing them as a batch can have advantages. For example, as discussed in Section 13 below, the identification of the source of a particular capture may be greatly enhanced by examining other captures made by the user at approximately the same time. In a fully connected system where live feedback is being provided to the user, the system is only able to use past captures when processing the current one. If the capture is one of a batch stored by the device when offline, however, the system will be able to take into account any data available from later captures as well as earlier ones when doing its analysis.

12.2. On a Host Device

A scanner will often communicate with some other device, such as a PC, PDA, phone or digital camera to perform many of the functions of the system, including more detailed interactions with the user.

12.2.1. Activities Performed in Response to a Capture

When the host device receives a capture, it may initiate a variety of activities. An incomplete list of possible activities performed by the system after locating and electronic counterpart document associated with the capture and a location within that document follows.

The details of the capture may be stored in the user’s history. (Section 6.1)

The document may be retrieved from local storage or a remote location. (Section 8)

The operating system’s metadata and other records associated with the document may be updated. (Section 11.1)

Markup associated with the document may be examined to determine the next relevant operations. (Section 5)

A software application may be started to edit, view or otherwise operate on the document. The choice of application may depend on the source document, or on the contents of the scan, or on some other aspect of the capture. (Section 11.2.2, 11.2.3)

The application may scroll to, highlight, move the insertion point to, or otherwise indicate the location of the capture. (Section 11.3)

The precise bounds of the captured text may be modified, for example to select whole words, sentences or paragraphs around the captured text. (Section 11.3.2)

The user may be given the option to copy the capture text to the clipboard or perform other standard operating system or application-specific operations upon it.

Annotations may be associated with the document or the captured text. These may come from immediate user input, or may have been captured earlier, for example in the case of voice annotations associated with an optical scan. (Section 19.4)

Markup may be examined to determine a set of further possible operations for the user to select.

12.2.2. Contextual Popup Menus

Sometimes the appropriate action to be taken by the system will be obvious, but sometimes it will require a choice to be made by the user. One good way to do this is through the use of “popup menus” or, in cases where the content is also being displayed on a screen, with so-called “contextual menus” that appear close to the content. (See Section 11.3.3). In some embodiments, the scanner device projects a popup menu onto the paper document. A user may select from such menus

using traditional methods such as a keyboard and mouse, or by using controls on the capture device (Section 12.1.2), gestures (Section 12.1.3), or by interacting with the computer display using the scanner (Section 12.2.4). In some embodiments, the popup menus which can appear as a result of a capture include default items representing actions which occur if the user does not respond—for example, if the user ignores the menu and makes another capture.

12.2.3. Feedback on Disambiguation

When a user starts capturing text, there will initially be several documents or other text locations that it could match. As more text is captured, and other factors are taken into account (Section 13), the number of candidate locations will decrease until the actual location is identified, or further disambiguation is not possible without user input. In some embodiments, the system provides a real-time display of the documents or the locations found, for example in list, thumbnail-image or text-segment form, and for the number of elements in that display to reduce in number as capture continues. In some embodiments, the system displays thumbnails of all candidate documents, where the size or position of the thumbnail is dependent on the probability of it being the correct match.

When a capture is unambiguously identified, this fact may be emphasized to the user, for example using audio feedback.

Sometimes the text captured will occur in many documents and will be recognized to be a quotation. The system may indicate this on the screen, for example by grouping documents containing a quoted reference around the original source document.

12.2.4. Scanning from Screen

Some optical scanners may be able to capture text displayed on a screen as well as on paper. Accordingly, the term rendered document is used herein to indicate that printing onto paper is not the only form of rendering, and that the capture of text or symbols for use by the system may be equally valuable when that text is displayed on an electronic display.

The user of the described system may be required to interact with a computer screen for a variety of other reasons, such as to select from a list of options. It can be inconvenient for the user to put down the scanner and start using the mouse or keyboard. Other sections have described physical controls on the scanner (Section 12.1.2) or gestures (Section 12.1.3) as methods of input which do not require this change of tool, but using the scanner on the screen itself to scan some text or symbol is an important alternative provided by the system.

In some embodiments, the optics of the scanner allow it to be used in a similar manner to a light-pen, directly sensing its position on the screen without the need for actual scanning of text, possibly with the aid of special hardware or software on the computer.

13. Context Interpretation

An important aspect of the described system is the use of other factors, beyond the simple capture of a string of text, to help identify the document in use. A capture of a modest amount of text may often identify the document uniquely, but in many situations it will identify a few candidate documents. One solution is to prompt the user to confirm the document being scanned, but a preferable alternative is to make use of other factors to narrow down the possibilities automatically. Such supplemental information can dramatically reduce the amount of text that needs to be captured and/or increase the reliability and speed with which the location in the electronic counterpart can be identified. This extra material is referred to as “context”, and it was discussed briefly in Section 4.2.2. We now consider it in more depth.

13.1. System and Capture Context

Perhaps the most important example of such information is the user’s capture history.

It is highly probable that any given capture comes from the same document as the previous one, or from an associated document, especially if the previous capture took place in the last few minutes (Section 6.1.2). Conversely, if the system detects that the font has changed between two scans, it is more likely that they are from different documents.

Also useful are the user’s longer-term capture history and reading habits. These can also be used to develop a model of the user’s interests and associations.

13.2. User’s Real-world Context

Another example of useful context is the user’s geographical location. A user in Paris is much more likely to be reading *Le Monde* than the *Seattle Times*, for example. The timing, size and geographical distribution of printed versions of the documents can therefore be important, and can to some degree be deduced from the operation of the system.

The time of day may also be relevant, for example in the case of a user who always reads one type of publication on the way to work, and a different one at lunchtime or on the train going home.

13.3. Related Digital Context

The user’s recent use of electronic documents, including those searched for or retrieved by more conventional means, can also be a helpful indicator.

In some cases, such as on a corporate network, other factors may be usefully considered:

Which documents have been printed recently?

Which documents have been modified recently on the corporate file server?

Which documents have been emailed recently?

All of these examples might suggest that a user was more likely to be reading a paper version of those documents. In contrast, if the repository in which a document resides can affirm that the document has never been printed sent anywhere where it might have been printed, then it can be safely eliminated in any searches originating from paper.

13.4. Other statistics—the Global Context

Section 14 covers the analysis of the data stream resulting from paper-based searches, but it should be noted here that statistics about the popularity of documents with other readers, about the timing of that popularity, and about the parts of documents most frequently scanned are all examples of further factors which can be beneficial in the search process. The system brings the possibility of Google-type page-ranking to the world of paper.

See also Section 4.2.2 for some other implications of the use of context for search engines.

14. Data-stream Analysis

The use of the system generates an exceedingly valuable data-stream as a side effect. This stream is a record of what users are reading and when, and is in many cases a record of what they find particularly valuable in the things they read. Such data has never really been available before for paper documents.

Some ways in which this data can be useful for the system, and for the user of the system, are described in Section 6.1. This section concentrates on its use for others. There are, of course, substantial privacy issues to be considered with any distribution of data about what people are reading, but such issues as preserving the anonymity of data are well known to those of skill in the art.

14.1. Document Tracking

When the system knows which documents any given user is reading, it can also deduce who is reading any given docu-

ment. This allows the tracking of a document through an organization, to allow analysis, for example, of who is reading it and when, how widely it was distributed, how long that distribution took, who has seen current versions while others are still working from out-of-date copies.

For published documents that have a wider distribution, the tracking of individual copies is more difficult, but the analysis of the distribution of readership is still possible.

14.2. Read Ranking—Popularity of Documents and Sub-regions

In situations where users are capturing text or other data that is of particular interest to them, the system can deduce the popularity of certain documents and of particular sub-regions of those documents. This forms a valuable input to the system itself (Section 4.2.2) and an important source of information for authors, publishers and advertisers (Section 7.6, Section 10.5). This data is also useful when integrated in search engines and search indices—for example, to assist in ranking search results for queries coming from rendered documents, and/or to assist in ranking conventional queries typed into a web browser.

14.3. Analysis of Users—Building Profiles

Knowledge of what a user is reading enables the system to create a quite detailed model of the user's interests and activities. This can be useful on an abstract statistical basis—"35% of users who buy this newspaper also read the latest book by that author"—but it can also allow other interactions with the individual user, as discussed below.

14.3.1. Social Networking

One example is connecting one user with others who have related interests. These may be people already known to the user. The system may ask a university professor, "Did you know that your colleague at XYZ University has also just read this paper?" The system may ask a user, "Do you want to be linked up with other people in your neighborhood who are also how reading Jane Eyre?" Such links may be the basis for the automatic formation of book clubs and similar social structures, either in the physical world or online.

14.3.2. Marketing

Section 10.6 has already mentioned the idea of offering products and services to an individual user based on their interactions with the system. Current online booksellers, for example, often make recommendations to a user based on their previous interactions with the bookseller. Such recommendations become much more useful when they are based on interactions with the actual books.

14.4. Marketing Based on Other Aspects of the data-stream

We have discussed some of the ways in which the system may influence those publishing documents, those advertising through them, and other sales initiated from paper (Section 10). Some commercial activities may have no direct interaction with the paper documents at all and yet may be influenced by them. For example, the knowledge that people in one community spend more time reading the sports section of the newspaper than they do the financial section might be of interest to somebody setting up a health club.

14.5. Types of Data that may be Captured

In addition to the statistics discussed, such as who is reading which bits of which documents, and when and where, it can be of interest to examine the actual contents of the text captured, regardless of whether or not the document has been located.

In many situations, the user will also not just be capturing some text, but will be causing some action to occur as a result. It might be emailing a reference to the document to an acquaintance, for example. Even in the absence of informa-

tion about the identity of the user or the recipient of the email, the knowledge that somebody considered the document worth emailing is very useful.

In addition to the various methods discussed for deducing the value of a particular document or piece of text, in some circumstances the user will explicitly indicate the value by assigning it a rating.

Lastly, when a particular set of users are known to form a group, for example when they are known to be employees of a particular company, the aggregated statistics of that group can be used to deduce the importance of a particular document to that group.

15. Device Features and Functions

A capture device for use with the system needs little more than a way of capturing text from a rendered version of the document. As described earlier (Section 1.2), this capture may be achieved through a variety of methods including taking a photograph of part of the document or typing some words into a mobile phone keypad. This capture may be achieved using a small hand-held optical scanner capable of recording a line or two of text at a time, or an audio capture device such as a voice-recorder into which the user is reading text from the document. The device used may be a combination of these—an optical scanner which could also record voice annotations, for example—and the capturing functionality may be built into some other device such as a mobile phone, PDA, digital camera or portable music player.

15.1. Input and Output

Many of the possibly beneficial additional input and output facilities for such a device have been described in Section 12.1. They include buttons, scroll-wheels and touch-pads for input, and displays, indicator lights, audio and tactile transducers for output. Sometimes the device will incorporate many of these, sometimes very few. Sometimes the capture device will be able to communicate with another device that already has them (Section 15.6), for example using a wireless link, and sometimes the capture functionality will be incorporated into such other device (Section 15.7).

15.2. Connectivity

In some embodiments, the device implements the majority of the system itself. In some embodiments, however, it often communicates with a PC or other computing device and with the wider world using communications facilities.

Often these communications facilities are in the form of a general-purpose data network such as Ethernet, 802.11 or UWB or a standard peripheral-connecting network such as USB, IEEE-1394 (Firewire), Bluetooth™ or infra-red. When a wired connection such as Firewire or USB is used, the device may receive electrical power though the same connection. In some circumstances, the capture device may appear to a connected machine to be a conventional peripheral such as a USB storage device.

Lastly, the device may in some circumstances "dock" with another device, either to be used in conjunction with that device or for convenient storage.

15.3. Caching and Other Online/offline Functionality

Sections 3.5 and 12.1.4 have raised the topic of disconnected operation. When a capture device has a limited subset of the total system's functionality, and is not in communication with the other parts of the system, the device can still be useful, though the functionality available will sometimes be reduced. At the simplest level, the device can record the raw image or audio data being captured and this can be processed later. For the user's benefit, however, it can be important to give feedback where possible about whether the data captured is likely to be sufficient for the task in hand, whether it can be recognized or is likely to be recognizable, and whether the

source of the data can be identified or is likely to be identifiable later. The user will then know whether their capturing activity is worthwhile. Even when all of the above are unknown, the raw data can still be stored so that, at the very least, the user can refer to them later. The user may be presented with the image of a scan, for example, when the scan cannot be recognized by the OCR process.

To illustrate some of the range of options available, both a rather minimal optical scanning device and then a much more full-featured one are described below. Many devices occupy a middle ground between the two.

15.3.1. The SimpleScanner—a Low-end Offline Example

The SimpleScanner has a scanning head able to read pixels from the page as it is moved along the length of a line of text. It can detect its movement along the page and record the pixels with some information about the movement. It also has a clock, which allows each scan to be time-stamped. The clock is synchronized with a host device when the SimpleScanner has connectivity. The clock may not represent the actual time of day, but relative times may be determined from it so that the host can deduce the actual time of a scan, or at worst the elapsed time between scans.

The SimpleScanner does not have sufficient processing power to perform any OCR itself, but it does have some basic knowledge about typical word-lengths, word-spacings, and their relationship to font size. It has some basic indicator lights which tell the user whether the scan is likely to be readable, whether the head is being moved too fast, too slowly or too inaccurately across the paper, and when it determines that sufficient words of a given size are likely to have been scanned for the document to be identified.

The SimpleScanner has a USB connector and can be plugged into the USB port on a computer, where it will be recharged. To the computer it appears to be a USB storage device on which time-stamped data files have been recorded, and the rest of the system software takes over from this point.

15.3.2. The SuperScanner—a High-end Offline Example

The SuperScanner also depends on connectivity for its full operation, but it has a significant amount of on-board storage and processing which can help it make better judgments about the data captured while offline.

As it moves along the line of text, the captured pixels are stitched together and passed to an OCR engine that attempts to recognize the text. A number of fonts, including those from the user's most-read publications, have been downloaded to it to help perform this task, as has a dictionary that is synchronized with the user's spelling-checker dictionary on their PC and so contains many of the words they frequently encounter. Also stored on the scanner is a list of words and phrases with the typical frequency of their use—this may be combined with the dictionary. The scanner can use the frequency statistics both to help with the recognition process and also to inform its judgment about when a sufficient quantity of text has been captured; more frequently used phrases are less likely to be useful as the basis for a search query.

In addition, the full index for the articles in the recent issues of the newspapers and periodicals most commonly read by the user are stored on the device, as are the indices for the books the user has recently purchased from an online bookseller, or from which the user has scanned anything within the last few months. Lastly, the titles of several thousand of the most popular publications which have data available for the system are stored so that, in the absence of other information the user can scan the title and have a good idea as to whether or not captures from a particular work are likely to be retrievable in electronic form later.

During the scanning process, the system informs user that the captured data has been of sufficient quality and of a sufficient nature to make it probable that the electronic copy can be retrieved when connectivity is restored. Often the system indicates to the user that the scan is known to have been successful and that the context has been recognized in one of the on-board indices, or that the publication concerned is known to be making its data available to the system, so the later retrieval ought to be successful.

The SuperScanner docks in a cradle connected to a PC's Firewire or USB port, at which point, in addition to the upload of captured data, its various onboard indices and other databases are updated based on recent user activity and new publications. It also has the facility to connect to wireless public networks or to communicate via Bluetooth to a mobile phone and thence with the public network when such facilities are available.

15.4. Features for Optical Scanning

We now consider some of the features that may be particularly desirable in an optical scanner device.

15.4.1. Flexible Positioning and Convenient Optics

One of the reasons for the continuing popularity of paper is the ease of its use in a wide variety of situations where a computer, for example, would be impractical or inconvenient. A device intended to capture a substantial part of a user's interaction with paper should therefore be similarly convenient in use. This has not been the case for scanners in the past; even the smallest hand-held devices have been somewhat unwieldy. Those designed to be in contact with the page have to be held at a precise angle to the paper and moved very carefully along the length of the text to be scanned. This is acceptable when scanning a business report on an office desk, but may be impractical when scanning a phrase from a novel while waiting for a train. Scanners based on camera-type optics that operate at a distance from the paper may similarly be useful in some circumstances.

Some embodiments of the system use a scanner that scans in contact with the paper, and which, instead of lenses, uses an image conduit a bundle of optical fibers to transmit the image from the page to the optical sensor device. Such a device can be shaped to allow it to be held in a natural position; for example, in some embodiments, the part in contact with the page is wedge-shaped, allowing the user's hand to move more naturally over the page in a movement similar to the use of a highlighter pen. The conduit is either in direct contact with the paper or in close proximity to it, and may have a replaceable transparent tip that can protect the image conduit from possible damage. As has been mentioned in Section 12.2.4, the scanner may be used to scan from a screen as well as from paper, and the material of the tip can be chosen to reduce the likelihood of damage to such displays.

Lastly, some embodiments of the device will provide feedback to the user during the scanning process which will indicate through the use of light, sound or tactile feedback when the user is scanning too fast, too slow, too unevenly or is drifting too high or low on the scanned line.

15.5. Security, Identity, Authentication, Personalization and Billing

As described in Section 6, the capture device may form an important part of identification and authorization for secure transactions, purchases, and a variety of other operations. It may therefore incorporate, in addition to the circuitry and software required for such a role, various hardware features that can make it more secure, such as a smartcard reader, RFID, or a keypad on which to type a PIN.

It may also include various biometric sensors to help identify the user. In the case of an optical scanner, for example, the

scanning head may also be able to read a fingerprint. For a voice recorder, the voice pattern of the user may be used.

15.6. Device Associations

In some embodiments, the device is able to form an association with other nearby devices to increase either its own or their functionality. In some embodiments, for example, it uses the display of a nearby PC or phone to give more detailed feedback about its operation, or uses their network connectivity. The device may, on the other hand, operate in its role as a security and identification device to authenticate operations performed by the other device. Or it may simply form an association in order to function as a peripheral to that device.

An interesting aspect of such associations is that they may be initiated and authenticated using the capture facilities of the device. For example, a user wishing to identify themselves securely to a public computer terminal may use the scanning facilities of the device to scan a code or symbol displayed on a particular area of the terminal's screen and so effect a key transfer. An analogous process may be performed using audio signals picked up by a voice-recording device.

15.7. Integration with Other Devices

In some embodiments, the functionality of the capture device is integrated into some other device that is already in use. The integrated devices may be able to share a power supply, data capture and storage capabilities, and network interfaces. Such integration may be done simply for convenience, to reduce cost, or to enable functionality that would not otherwise be available.

Some examples of devices into which the capture functionality can be integrated include:

- an existing peripheral such as a mouse, a stylus, a USB "webcam" camera, a Bluetooth™ headset or a remote control

- another processing/storage device, such as a PDA, an MP3 player, a voice recorder, a digital camera or a mobile phone

- other often-carried items, just for convenience—a watch, a piece of jewelry, a pen, a car key fob

15.7.1. Mobile Phone Integration

As an example of the benefits of integration, we consider the use of a modified mobile phone as the capture device.

In some embodiments, the phone hardware is not modified to support the system, such as where the text capture can be adequately done through voice recognition, where they can either be processed by the phone itself, or handled by a system at the other end of a telephone call, or stored in the phone's memory for future processing. Many modern phones have the ability to download software that could implement some parts of the system. Such voice capture is likely to be suboptimal in many situations, however, for example when there is substantial background noise, and accurate voice recognition is a difficult task at the best of times. The audio facilities may best be used to capture voice annotations.

In some embodiments, the camera built into many mobile phones is used to capture an image of the text. The phone display, which would normally act as a viewfinder for the camera, may overlay on the live camera image information about the quality of the image and its suitability for OCR, which segments of text are being captured, and even a transcription of the text if the OCR can be performed on the phone.

In some embodiments, the phone is modified to add dedicated capture facilities, or to provide such functionality in a clip-on adaptor or a separate Bluetooth-connected peripheral in communication with the phone. Whatever the nature of the capture mechanism, the integration with a modern cellphone has many other advantages. The phone has connectivity with

the wider world, which means that queries can be submitted to remote search engines or other parts of the system, and copies of documents may be retrieved for immediate storage or viewing. A phone typically has sufficient processing power for many of the functions of the system to be performed locally, and sufficient storage to capture a reasonable amount of data. The amount of storage can also often be expanded by the user. Phones have reasonably good displays and audio facilities to provide user feedback, and often a vibrate function for tactile feedback. They also have good power supplies.

Most significantly of all, they are a device that most users are already carrying.

Part III—Example Applications of the System

This section lists example uses of the system and applications that may be built on it. This list is intended to be purely illustrative and in no sense exhaustive.

16. Personal Applications

16.1. Life Library

The Life Library (see also Section 6.1.1) is a digital archive of any important documents that the subscriber wishes to save and is a set of embodiments of services of this system. Important books, magazine articles, newspaper clippings, etc., can all be saved in digital form in the Life Library. Additionally, the subscriber's annotations, comments, and notes can be saved with the documents. The Life Library can be accessed via the Internet and World Wide Web.

The system creates and manages the Life Library document archive for subscribers. The subscriber indicates which documents the subscriber wishes to have saved in his life library by scanning information from the document or by otherwise indicating to the system that the particular document is to be added to the subscriber's Life Library. The scanned information is typically text from the document but can also be a barcode or other code identifying the document. The system accepts the code and uses it to identify the source document. After the document is identified the system can store either a copy of the document in the user's Life Library or a link to a source where the document may be obtained.

One embodiment of the Life Library system can check whether the subscriber is authorized to obtain the electronic copy. For example, if a reader scans text or an identifier from a copy of an article in the New York Times (NYT) so that the article will be added to the reader's Life Library, the Life Library system will verify with the NYT whether the reader is subscribed to the online version of the NYT; if so, the reader gets a copy of the article stored in his Life Library account; if not, information identifying the document and how to order it is stored in his Life Library account.

In some embodiments, the system maintains a subscriber profile for each subscriber that includes access privilege information. Document access information can be compiled in several ways, two of which are: 1) the subscriber supplies the document access information to the Life Library system, along with his account names and passwords, etc., or 2) the Life Library service provider queries the publisher with the subscriber's information and the publisher responds by providing access to an electronic copy if the Life Library subscriber is authorized to access the material. If the Life Library subscriber is not authorized to have an electronic copy of the document, the publisher provides a price to the Life Library service provider, which then provides the customer with the option to purchase the electronic document. If so, the Life Library service provider either pays the publisher directly and bills the Life Library customer later or the Life Library service provider immediately bills the customer's credit card for

the purchase. The Life Library service provider would get a percentage of the purchase price or a small fixed fee for facilitating the transaction.

The system can archive the document in the subscriber's personal library and/or any other library to which the subscriber has archival privileges. For example, as a user scans text from a printed document, the Life Library system can identify the rendered document and its electronic counterpart. After the source document is identified, the Life Library system might record information about the source document in the user's personal library and in a group library to which the subscriber has archival privileges. Group libraries are collaborative archives such as a document repository for a group working together on a project, a group of academic researchers, a group web log, etc.

The life library can be organized in many ways: chronologically, by topic, by level of the subscriber's interest, by type of publication (newspaper, book, magazine, technical paper, etc.), where read, when read, by ISBN or by Dewey decimal, etc. In one alternative, the system can learn classifications based on how other subscribers have classified the same document. The system can suggest classifications to the user or automatically classify the document for the user.

In various embodiments, annotations may be inserted directly into the document or may be maintained in a separate file. For example, when a subscriber scans text from a newspaper article, the article is archived in his Life Library with the scanned text highlighted. Alternatively, the article is archived in his Life Library along with an associated annotation file (thus leaving the archived document unmodified). Embodiments of the system can keep a copy of the source document in each subscriber's library, a copy in a master library that many subscribers can access, or link to a copy held by the publisher.

In some embodiments, the Life Library stores only the user's modifications to the document (e.g., highlights, etc.) and a link to an online version of the document (stored elsewhere). The system or the subscriber merges the changes with the document when the subscriber subsequently retrieves the document.

If the annotations are kept in a separate file, the source document and the annotation file are provided to the subscriber and the subscriber combines them to create a modified document. Alternatively, the system combines the two files prior to presenting them to the subscriber. In another alternative, the annotation file is an overlay to the document file and can be overlaid on the document by software in the subscriber's computer.

Subscribers to the Life Library service pay a monthly fee to have the system maintain the subscriber's archive. Alternatively, the subscriber pays a small amount (e.g., a micro-payment) for each document stored in the archive. Alternatively, the subscriber pays to access the subscriber's archive on a per-access fee. Alternatively, subscribers can compile libraries and allow others to access the materials/annotations on a revenue share model with the Life Library service provider and copyright holders. Alternatively, the Life Library service provider receives a payment from the publisher when the Life Library subscriber orders a document (a revenue share model with the publisher, where the Life Library service provider gets a share of the publisher's revenue).

In some embodiments, the Life Library service provider acts as an intermediary between the subscriber and the copyright holder (or copyright holder's agent, such as the Copyright Clearance Center, a.k.a. CCC) to facilitate billing and payment for copyrighted materials. The Life Library service provider uses the subscriber's billing information and other

user account information to provide this intermediation service. Essentially, the Life Library service provider leverages the pre-existing relationship with the subscriber to enable purchase of copyrighted materials on behalf of the subscriber.

In some embodiments, the Life Library system can store excerpts from documents. For example, when a subscriber scans text from a paper document, the regions around the scanned text are excerpted and placed in the Life Library, rather than the entire document being archived in the life library. This is especially advantageous when the document is long because preserving the circumstances of the original scan prevents the subscriber from re-reading the document to find the interesting portions. Of course, a hyperlink to the entire electronic counterpart of the paper document can be included with the excerpt materials.

In some embodiments, the system also stores information about the document in the Life Library, such as author, publication title, publication date, publisher, copyright holder (or copyright holder's licensing agent), ISBN, links to public annotations of the document, readrank, etc. Some of this additional information about the document is a form of paper document metadata. Third parties may create public annotation files for access by persons other than themselves, such as the general public. Linking to a third party's commentary on a document is advantageous because reading annotation files of other users enhances the subscriber's understanding of the document.

In some embodiments, the system archives materials by class. This feature allows a Life Library subscriber to quickly store electronic counterparts to an entire class of paper documents without access to each paper document. For example, when the subscriber scans some text from a copy of National Geographic magazine, the system provides the subscriber with the option to archive all back issues of the National Geographic. If the subscriber elects to archive all back issues, the Life Library service provider would then verify with the National Geographic Society whether the subscriber is authorized to do so. If not, the Life Library service provider can mediate the purchase of the right to archive the National Geographic magazine collection.

16.2. Life Saver

A variation on, or enhancement of, the Life Library concept is the "Life Saver", where the system uses the text captured by a user to deduce more about their other activities. The scanning of a menu from a particular restaurant, a program from a particular theater performance, a timetable at a particular railway station, or an article from a local newspaper allows the system to make deductions about the user's location and social activities, and could construct an automatic diary for them, for example as a website. The user would be able to edit and modify the diary, add additional materials such as photographs and, of course, look again at the items scanned.

17. Academic Applications

Portable scanners supported by the described system have many compelling uses in the academic setting. They can enhance student/teacher interaction and augment the learning experience. Among other uses, students can annotate study materials to suit their unique needs; teachers can monitor classroom performance; and teachers can automatically verify source materials cited in student assignments.

17.1. Children's Books

A child's interaction with a paper document, such as a book, is monitored by a literacy acquisition system that employs a specific set of embodiments of this system. The child uses a portable scanner that communicates with other elements of the literacy acquisition system. In addition to the

portable scanner, the literacy acquisition system includes a computer having a display and speakers, and a database accessible by the computer. The scanner is coupled with the computer (hardwired, short range RF, etc.). When the child sees an unknown word in the book, the child scans it with the scanner. In one embodiment, the literacy acquisition system compares the scanned text with the resources in its database to identify the word. The database includes a dictionary, thesaurus, and/or multimedia files (e.g., sound, graphics, etc.). After the word has been identified, the system uses the computer speakers to pronounce the word and its definition to the child. In another embodiment, the word and its definition are displayed by the literacy acquisition system on the computer's monitor. Multimedia files about the scanned word can also be played through the computer's monitor and speakers. For example, if a child reading "Goldilocks and the Three Bears" scanned the word "bear", the system might pronounce the word "bear" and play a short video about bears on the computer's monitor. In this way, the child learns to pronounce the written word and is visually taught what the word means via the multimedia presentation.

The literacy acquisition system provides immediate auditory and/or visual information to enhance the learning process. The child uses this supplementary information to quickly acquire a deeper understanding of the written material. The system can be used to teach beginning readers to read, to help children acquire a larger vocabulary, etc. This system provides the child with information about words with which the child is unfamiliar or about which the child wants more information.

17.2. Literacy Acquisition

In some embodiments, the system compiles personal dictionaries. If the reader sees a word that is new, interesting, or particularly useful or troublesome, the reader saves it (along with its definition) to a computer file. This computer file becomes the reader's personalized dictionary. This dictionary is generally smaller in size than a general dictionary so can be downloaded to a mobile station or associated device and thus be available even when the system isn't immediately accessible. In some embodiments, the personal dictionary entries include audio files to assist with proper word pronunciation and information identifying the paper document from which the word was scanned.

In some embodiments, the system creates customized spelling and vocabulary tests for students. For example, as a student reads an assignment, the student may scan unfamiliar words with the portable scanner. The system stores a list of all the words that the student has scanned. Later, the system administers a customized spelling/vocabulary test to the student on an associated monitor (or prints such a test on an associated printer).

17.3. Music Teaching

The arrangement of notes on a musical staff is similar to the arrangement of letters in a line of text. The same scanning device discussed for capturing text in this system can be used to capture music notation, and an analogous process of constructing a search against databases of known musical pieces would allow the piece from which the capture occurred to be identified which can then be retrieved, played, or be the basis for some further action.

17.4. Detecting Plagiarism

Teachers can use the system to detect plagiarism or to verify sources by scanning text from student papers and submitting the scanned text to the system. For example, a teacher who wishes to verify that a quote in a student paper came from the source that the student cited can scan a portion of the quote and compare the title of the document identified by the system

with the title of the document cited by the student. Likewise, the system can use scans of text from assignments submitted as the student's original work to reveal if the text was instead copied.

17.5. Enhanced Textbook

In some embodiments, capturing text from an academic textbook links students or staff to more detailed explanations, further exercises, student and staff discussions about the material, related example past exam questions, further reading on the subject, recordings of the lectures on the subject, and so forth. (See also Section 7.1.)

17.6. Language Learning

In some embodiments, the system is used to teach foreign languages. Scanning a Spanish word, for example, might cause the word to be read aloud in Spanish along with its definition in English.

The system provides immediate auditory and/or visual information to enhance the new language acquisition process. The reader uses this supplementary information to acquire quickly a deeper understanding of the material. The system can be used to teach beginning students to read foreign languages, to help students acquire a larger vocabulary, etc. The system provides information about foreign words with which the reader is unfamiliar or for which the reader wants more information.

Reader interaction with a paper document, such as a newspaper or book, is monitored by a language skills system. The reader has a portable scanner that communicates with the language skills system. In some embodiments, the language skills system includes a computer having a display and speakers, and a database accessible by the computer. The scanner communicates with the computer (hardwired, short range RF, etc.). When the reader sees an unknown word in an article, the reader scans it with the scanner. The database includes a foreign language dictionary, thesaurus, and/or multimedia files (sound, graphics, etc.). In one embodiment, the system compares the scanned text with the resources in its database to identify the scanned word. After the word has been identified, the system uses the computer speakers to pronounce the word and its definition to the reader. In some embodiments, the word and its definition are both displayed on the computer's monitor. Multimedia files about grammar tips related to the scanned word can also be played through the computer's monitor and speakers. For example, if the words "to speak" are scanned, the system might pronounce the word "hablar," play a short audio clip that demonstrates the proper Spanish pronunciation, and display a complete list of the various conjugations of "hablar". In this way, the student learns to pronounce the written word, is visually taught the spelling of the word via the multimedia presentation, and learns how to conjugate the verb. The system can also present grammar tips about the proper usage of "hablar" along with common phrases.

In some embodiments, the user scans a word or short phrase from a rendered document in a language other than the user's native language (or some other language that the user knows reasonably well). In some embodiments, the system maintains a prioritized list of the user's "preferred" languages. The system identifies the electronic counterpart of the rendered document, and determines the location of the scan within the document. The system also identifies a second electronic counterpart of the document that has been translated into one of the user's preferred languages, and determines the location in the translated document corresponding to the location of the scan in the original document. When the corresponding location is not known precisely, the system identifies a small region (e.g., a paragraph) that includes the

corresponding location of the scanned location. The corresponding translated location is then presented to the user. This provides the user with a precise translation of the particular usage at the scanned location, including any slang or other idiomatic usage that is often difficult to accurately translate on a word-by-word basis.

17.7. Gathering Research Materials

A user researching a particular topic may encounter all sorts of material, both in print and on screen, which they might wish to record as relevant to the topic in some personal archive. The system would enable this process to be automatic as a result of scanning a short phrase in any piece of material, and could also create a bibliography suitable for insertion into a publication on the subject.

18. Commercial Applications

Obviously, commercial activities could be made out of almost any process discussed in this document, but here we concentrate on a few obvious revenue streams.

18.1. Fee-based Searching and Indexing

Conventional Internet search engines typically provide free search of electronic documents, and also make no charge to the content providers for including their content in the index. In some embodiments, the system provides for charges to users and/or payments to search engines and/or content providers in connection with the operation and use of the system.

In some embodiments, subscribers to the system's services pay a fee for searches originating from scans of paper documents. For example, a stockbroker may be reading a Wall Street Journal article about a new product offered by Company X. By scanning the Company X name from the paper document and agreeing to pay the necessary fees, the stockbroker uses the system to search special or proprietary databases to obtain premium information about the company, such as analyst's reports. The system can also make arrangements to have priority indexing of the documents most likely to be read in paper form, for example by making sure all of the newspapers published on a particular day are indexed and available by the time they hit the streets.

Content providers may pay a fee to be associated with certain terms in search queries submitted from paper documents. For example, in one embodiment, the system chooses a most preferred content provider based on additional context about the provider (the context being, in this case, that the content provider has paid a fee to be moved up the results list). In essence, the search provider is adjusting paper document search results based on pre-existing financial arrangements with a content provider. See also the description of keywords and key phrases in Section 5.2.

Where access to particular content is to be restricted to certain groups of people (such as clients or employees), such content may be protected by a firewall and thus not generally indexable by third parties. The content provider may nonetheless wish to provide an index to the protected content. In such a case, the content provider can pay a service provider to provide the content provider's index to system subscribers. For example, a law firm may index all of a client's documents. The documents are stored behind the law firm's firewall. However, the law firm wants its employees and the client to have access to the documents through the portable scanner so it provides the index (or a pointer to the index) to the service provider, which in turn searches the law firm's index when employees or clients of the law firm submit paper-scanned search terms via their portable scanners. The law firm can provide a list of employees and/or clients to the service provider's system to enable this function or the system can verify access rights by querying the law firm prior to searching the

law firm's index. Note that in the preceding example, the index provided by the law firm is only of that client's documents, not an index of all documents at the law firm. Thus, the service provider can only grant the law firm's clients access to the documents that the law firm indexed for the client.

There are at least two separate revenue streams that can result from searches originating from paper documents: one revenue stream from the search function, and another from the content delivery function. The search function revenue can be generated from paid subscriptions from the scanner users, but can also be generated on a per-search charge. The content delivery revenue can be shared with the content provider or copyright holder (the service provider can take a percentage of the sale or a fixed fee, such as a micropayment, for each delivery), but also can be generated by a "referral" model in which the system gets a fee or percentage for every item that the subscriber orders from the online catalog and that the system has delivered or contributed to, regardless of whether the service provider intermediates the transaction. In some embodiments, the system service provider receives revenue for all purchases that the subscriber made from the content provider, either for some predetermined period of time or at any subsequent time when a purchase of an identified product is made.

18.2. Catalogs

Consumers may use the portable scanner to make purchases from paper catalogs. The subscriber scans information from the catalog that identifies the catalog. This information is text from the catalog, a bar code, or another identifier of the catalog. The subscriber scans information identifying the products that s/he wishes to purchase. The catalog mailing label may contain a customer identification number that identifies the customer to the catalog vendor. If so, the subscriber can also scan this customer identification number. The system acts as an intermediary between the subscriber and the vendor to facilitate the catalog purchase by providing the customer's selection and customer identification number to the vendor.

18.3. Coupons

A consumer scans paper coupons and saves an electronic copy of the coupon in the scanner, or in a remote device such as a computer, for later retrieval and use. An advantage of electronic storage is that the consumer is freed from the burden of carrying paper coupons. A further advantage is that the electronic coupons may be retrieved from any location. In some embodiments, the system can track coupon expiration dates, alert the consumer about coupons that will expire soon, and/or delete expired coupons from storage. An advantage for the issuer of the coupons is the possibility of receiving more feedback about who is using the coupons and when and where they are captured and used.

19. General Applications

19.1. Forms

The system may be used to auto-populate an electronic document that corresponds to a paper form. A user scans in some text or a barcode that uniquely identifies the paper form. The scanner communicates the identity of the form and information identifying the user to a nearby computer. The nearby computer has an Internet connection. The nearby computer can access a first database of forms and a second database having information about the user of the scanner (such as a service provider's subscriber information database). The nearby computer accesses an electronic version of the paper form from the first database and auto-populates the fields of the form from the user's information obtained from the second database. The nearby computer then emails the completed form to the intended recipient. Alternatively, the computer could print the completed form on a nearby printer.

Rather than access an external database, in some embodiments, the system has a portable scanner that contains the user's information, such as in an identity module, SIM, or security card. The scanner provides information identifying the form to the nearby PC. The nearby PC accesses the electronic form and queries the scanner for any necessary information to fill out the form.

19.2. Business Cards

The system can be used to automatically populate electronic address books or other contact lists from paper documents. For example, upon receiving a new acquaintance's business card, a user can capture an image of the card with his/her cellular phone. The system will locate an electronic copy of the card, which can be used to update the cellular phone's onboard address book with the new acquaintance's contact information. The electronic copy may contain more information about the new acquaintance than can be squeezed onto a business card. Further, the onboard address book may also store a link to the electronic copy such that any changes to the electronic copy will be automatically updated in the cell phone's address book. In this example, the business card optionally includes a symbol or text that indicates the existence of an electronic copy. If no electronic copy exists, the cellular phone can use OCR and knowledge of standard business card formats to fill out an entry in the address book for the new acquaintance. Symbols may also aid in the process of extracting information directly from the image. For example, a phone icon next to the phone number on the business card can be recognized to determine the location of the phone number.

19.3. Proofreading/Editing

The system can enhance the proofreading and editing process. One way the system can enhance the editing process is by linking the editor's interactions with a paper document to its electronic counterpart. As an editor reads a paper document and scans various parts of the document, the system will make the appropriate annotations or edits to an electronic counterpart of the paper document. For example, if the editor scans a portion of text and makes the "new paragraph" control gesture with the scanner, a computer in communication with the scanner would insert a "new paragraph" break at the location of the scanned text in the electronic copy of the document.

19.4. Voice Annotation

A user can make voice annotations to a document by scanning a portion of text from the document and then making a voice recording that is associated with the scanned text. In some embodiments, the scanner has a microphone to record the user's verbal annotations. After the verbal annotations are recorded, the system identifies the document from which the text was scanned, locates the scanned text within the document, and attaches the voice annotation at that point. In some embodiments, the system converts the speech to text and attaches the annotation as a textual comment.

In some embodiments, the system keeps annotations separate from the document, with only a reference to the annotation kept with the document. The annotations then become an annotation markup layer to the document for a specific subscriber or group of users.

In some embodiments, for each capture and associated annotation, the system identifies the document, opens it using a software package, scrolls to the location of the scan and plays the voice annotation. The user can then interact with a document while referring to voice annotations, suggested changes or other comments recorded either by themselves or by somebody else.

19.5. Help In Text

The described system can be used to enhance paper documents with electronic help menus. In some embodiments, a markup layer associated with a paper document contains help menu information for the document. For example, when a user scans text from a certain portion of the document, the system checks the markup associated with the document and presents a help menu to the user. The help menu is presented on a display on the scanner or on an associated nearby display.

19.6. Use with Displays

In some situations, it is advantageous to be able to scan information from a television, computer monitor, or other similar display. In some embodiments, the portable scanner is used to scan information from computer monitors and televisions. In some embodiments, the portable optical scanner has an illumination sensor that is optimized to work with traditional cathode ray tube (CRT) display techniques such as rasterizing, screen blanking, etc.

A voice capture device which operates by capturing audio of the user reading text from a document will typically work regardless of whether that document is on paper, on a display, or on some other medium.

19.6.1. Public Kiosks and Dynamic Session IDs

One use of the direct scanning of displays is the association of devices as described in Section 15.6. For example, in some embodiments, a public kiosk displays a dynamic session ID on its monitor. The kiosk is connected to a communication network such as the Internet or a corporate intranet. The session ID changes periodically but at least every time that the kiosk is used so that a new session ID is displayed to every user. To use the kiosk, the subscriber scans in the session ID displayed on the kiosk; by scanning the session ID, the user tells the system that he wishes to temporarily associate the kiosk with his scanner for the delivery of content resulting from scans of printed documents or from the kiosk screen itself. The scanner may communicate the Session ID and other information authenticating the scanner (such as a serial number, account number, or other identifying information) directly to the system. For example, the scanner can communicate directly (where "directly" means without passing the message through the kiosk) with the system by sending the session initiation message through the user's cell phone (which is paired with the user's scanner via Bluetooth™). Alternatively, the scanner can establish a wireless link with the kiosk and use the kiosk's communication link by transferring the session initiation information to the kiosk (perhaps via short range RF such as Bluetooth™, etc.); in response, the kiosk sends the session initiation information to the system via its Internet connection.

The system can prevent others from using a device that is already associated with a scanner during the period (or session) in which the device is associated with the scanner. This feature is useful to prevent others from using a public kiosk before another person's session has ended. As an example of this concept related to use of a computer at an Internet café, the user scans a barcode on a monitor of a PC which s/he desires to use; in response, the system sends a session ID to the monitor that it displays; the user initiates the session by scanning the session ID from the monitor (or entering it via a keypad or touch screen or microphone on the portable scanner); and the system associates in its databases the session ID with the serial number (or other identifier that uniquely identifies the user's scanner) of his/her scanner so another scanner cannot scan the session ID and use the monitor during his/her session. The scanner is in communication (through wireless link such as Bluetooth™, a hardwired link such as a docking station, etc.) with a PC associated with the monitor or is in

direct (i.e., w/o going through the PC) communication with the system via another means such as a cellular phone, etc.

Part IV—System Details

Introduction

In some embodiments, the system captures text from a rendered document and associates some action, data, or functionality with that capture. Section 13 introduced the idea of using supplemental information about the circumstances under which a capture is performed, together with supplemental information about the user who performed the capture (sometimes collectively called “context”), as well as the data actually captured, to interpret the meaning of the capture and to determine the associations and actions that should appropriately follow. This is in contrast, for example, to conventional web search engines, which typically maintain very little context information from one search invocation to another, and know little about the circumstances under which the search query was performed.

By considering context, the system can reduce many degrees of uncertainty in its processes. For example, if the captured data could have come from any of several documents, the system can use the context to discard many that would be highly unlikely and help prioritize those that remain. Similarly, if the source of a capture is recognized but there are many actions that the user may wish to take as a result, the context can be a valuable aid in deciding which one should be the default. The uses to which the system puts context in various embodiments are discussed in more detail below.

FIG. 4 is a block diagram showing some of the components typically incorporated in at least some of the computer systems and other devices used by the system. These computer systems and devices 400 may include one or more central processing units (“CPUs”) 401 for executing computer programs; a computer memory 402 for storing programs and data while they are being used; a persistent storage device 403, such as a hard drive for persistently storing programs and data; a computer-readable media drive 404, such as a CD-ROM drive, for reading programs and data stored on a computer-readable medium; and a network connection 405 for connecting the computer system to other computer systems, such as via the Internet. While computer systems configured as described above are typically used to support the operation of the system, those skilled in the art will appreciate that the system may be implemented using devices of various types and configurations, and having various components.

FIG. 5 is a data flow diagram showing a typical manner in which the system uses context information. The system 510 receives a number of inputs, including the text 521 captured by the user in a capture operation; supplemental capture information 522 relating to the circumstances under which the capture operation was performed; and information 523 about the user performing the capture. Using these inputs, the system makes one or more determinations. In some embodiments, the system uses the inputs to determine the document in which and the position at which the capture operation was performed 531. In some embodiments, the system uses the inputs to determine what actions to perform automatically or offer to perform in response to the capture 532.

User Context

The user context can be summarized as “who, what, when and where,” or as the four basic factors of identity, activity, time and location. All of these factors can profitably be considered as an input to the system.

Identity

In many circumstances, the identity of the user is the most important piece of context to a capture, since the system is attempting to optimize the results for a particular user, based

on deductions about that user’s real-world activities and thought processes. The user identity can in some cases be deduced from the identity of the capture device, which is owned by or dedicated to him. In other circumstances, the identity of the user can be established, for example, by entering a code or password, by swiping an identity card, or through the use of biometric sensors.

The topic of identity also includes personalization—what else is known about the user. His specific preferences with regard to the system are of course important, but in some embodiments, the system considers other information. In some embodiments, the system considers other information. Examples are any other accounts the user may hold—for example with online bookstores—or subscriptions to newspapers.

Time

The time at which a capture occurs is important both in terms of simple linear time, which may be used to analyze the temporal sequence and proximity of events, and time within a given period, such as the time of day or the time within the week, which may be used to establish patterns. A user may habitually read a newspaper on the train on the way to work, for example, and a novel on the way home.

The use of timestamps in relation to other events, and the concept of a history of capture contexts, is discussed in more detail below.

Location

A user who is in a particular city is more likely to be reading a newspaper local to that city. A user who is in a library is probably reading something that is listed in that library’s catalog. The geographical location of the capture, therefore, can be very important, and while this is often expressed in terms of latitude and longitude, other means of describing it can also be useful. Examples include proximity to some entity or type of entity—“the user is in a restaurant”—or the location in terms of some other infrastructure, such as a network—“the user is connected via this wireless endpoint” or “the user’s phone is in range of this cellular base station.”

In some embodiments, the system determines the location in terms as general as “indoors” or “outdoors,” which may be deduced from the light entering the sensor of an optical capture device. Similarly the system may deduce “on a train” or “in a quiet room” from the ambient noise of an audio capture device.

Activity

The user’s activity includes his interactions with the system, and the answer to such questions as: What else has the user captured? What did he do last time this situation occurred? What was he doing at the time of making this capture? But the user’s “activity” is by no means limited to his use of the system. Other examples of useful activity include interactions with digital documents, with search engines, with printers, and with other users, for example by means of phones, email, instant messaging, particularly when those communications involve transmission of or references to documents.

Immediate Capture Context

The capture device is primarily intended to capture text or symbols from the rendered document. In some embodiments the capture device is able to capture information that is supplemental and can provide valuable context. Examples include the font in which the text is printed, the colors of the text and the background, the location of line breaks, and the proximity of the edge of a column or the edge of a page. In some embodiments, the capture device is also able to pick up more detail about the physical nature of the rendered document; for example, that it is printed on glossy or matte paper,

that the paper has a watermark, that it was printed with a high- or low-resolution printer. A scan from glossy paper, for example, is unlikely to be from a newspaper article.

In some embodiments, the scanning device is able to scan from an electronic display as well as from a printed document. These different modes of use can be identified, and similar characteristics noted for displays as for printed documents. Examples of such characteristics include resolution, quality of display, and refresh rate.

In situations where such characteristics are not directly useful in determining system operation, the changes in the characteristics can still be of interest. For example, it may not be possible to deduce directly very much about the origin of a document from the nature of the printing, but if it is clear that the text in two successive scans came from two different printers, it is highly unlikely that they originate from the same document.

Document Location Context

Another type of capture context used by the system in some embodiments is the location of the capture within the rendered document. Important factors include whether the capture came from the beginning of the document or the end, the top, middle or bottom of a page, a sidebar, footnote or endnote, and the proximity to items such as pictures, tables, advertisements, and quotations. Such factors may be considered analogies in the Capture Context to geographical location in the User Context.

Other Device Capabilities

In some embodiments, sensors in the capture device can detect other aspects of the capture environment. For example, the nature of the ambient light—is it daylight, tungsten filament, or a fluorescent source? In the case of audio capture, the system can deduce information from the background noise or from the speech patterns of the user reading the text. As has been mentioned in section 6.2.2, the capture sensor may be used to identify the user, for example as a biometric sensor by scanning the fingerprint.

The capture device may include other sensors, which can provide further information about its environment. Examples include GPS receivers, RFID tags, temperature sensors, wireless network interfaces. When the device does not directly include such facilities, it may be able to communicate with other devices that do.

Connectivity

The degree of connectivity of the capture device can affect many aspects of the system. Whether the device is “online,” “offline” or somewhere in-between can affect the confidence with which the captured document can be identified, the options available to the user, the statistics available from the rest of the system, to name just a few factors.

Other Captures

The broader capture context includes the documents or types of documents recently, or typically, scanned by a user. As an example, the system may deduce that one user only ever captures text from novels, while another only captures from recent newspaper editions. Similarly, one user may have the habit of scanning titles, headings and authors, where another is more likely to capture bibliographic cross-references. Such information can be useful in interpreting any particular capture.

Other Aspects & Extra Dimensions

Time

Most of the above factors have been described in terms of the immediate context: the status at the time of the capture. In some embodiments, the system adds an extra dimension of time. Most of the contextual factors described above may be offset in time from the actual capture. For example, it is

unlikely that a user would be scanning a document while composing an email to somebody, but the fact that a user sends a document to somebody shortly after a capture may be a strong hint as to the identity of the document.

A significant part of the context of any capture is the details of any captures that came before it and the captures that will come after, both in terms of the context in which they occurred, the data that was actually captured, and any actions that occurred as a result. In some embodiments, it is unusual that any capture will be examined in complete isolation.

The most obvious example is that two captures within a few seconds of each other are very likely to come from the same document. What is more, the second capture is probably from later in the document than the first one because users tend to read from beginning to end. Two captures which are several days apart are much less likely to be from the same document, especially if that document is a short one.

Similarly, if an examination of a user’s capture history indicates that he typically reads the New York Times between 7 am and 9 am each morning, then the likelihood is much greater that any new capture made during that period came from that source.

In some embodiments, the system distinguishes between the context at the time the capture occurred and the context now. In some cases, all of the interactions with the system will take place at the time the capture occurs. In other circumstances, system operations may be performed at a different time from the capture. This may occur, for example, where the capture device has no connectivity at the time of capture, or when the user returns to examine earlier captures logged in the user’s Life Library Archive as described in Section 6.1. In such cases, the system either selects the capture time or the processing time as the time most relevant to the capture, or considers both times.

In some embodiments, the system also considers the future in its analysis. There are two senses in which this may occur: 1) The system predicts the context in which the user will shortly find himself. For example, it may be more likely that the user is reading a book about a particular city not because he is in that city, but because he is on a plane heading towards it. Similarly, a user is more likely to be scanning a document by or about a particular person if his schedule indicates that he has a meeting with that person shortly. 2) The system or the user may be examining or interacting with a capture event from the past, and so can interpret that event in the light of things that happened afterwards. Thus the system might make a deduction that a certain capture was from the Seattle Times because the capture that followed it was from the menu of a Seattle restaurant.

In some embodiments, the system also proactively informs the user if information that the system receives affects the way past captures could be interpreted.

The Device and the User

In some embodiments, the system assumes that the context of the device and the context of the user are the same. This is often, but not always, the case. In some embodiments, the user may use multiple devices, and in others multiple users may use a single device, such as where the device is tethered and in a public place such as a store or a library. As discussed above, it may be necessary to establish the identity of the user separately from that of the device.

Use of the System to Establish Context

While much of the foregoing discussion is focused on the use of context to influence the operation of the system, there are many situations in which the use of the system can also help to establish the context.

To take the example of geographical location, it can be useful to establish the location of a user by means independent of document identification performed by the system, such as by using a GPS receiver or the location of a wireless network to which the user is connected. In the absence of such direct information, however, some embodiments deduce the geographical context from the use of the system. Thus, the times of day at which the system is used are an important clue as to the time zone in which the user is located. In some embodiments, the system also considers the capture of information in a particular language or from a document likely to be very locally-targeted, such as a local newspaper, a public transport timetable, a restaurant menu.

Such indications are not always completely reliable—for example, the user may have taken the restaurant menu home with him. Despite this, the consideration of such indications in probabilistic analysis can be very useful. In some embodiments, the system performs filtering to remove rogue indications. If the system has a strong indication that a user is in London, for example, the system ascribes a low likelihood of accuracy to any suggestion that he is in San Francisco two hours later.

The Other Users

In some embodiments, the system also makes use of the information about the activities and context of other users, especially as they relate to the capture at hand, such as by being relevant to the user's location or the document being scanned. That is, the system can make use of concepts such as:

“Other people in Boston are reading this book at the moment,” or

“This magazine article has been very popular in the last week,” or

“Users who also read that review often went on to scan passages from this book.”

Making Use of Context

Many aspects of the system benefit from the availability of context information.

Operation of the system typically begins with the capture of some data from the rendered document, and the use of that data to identify an electronic counterpart to the rendered document. An example is scanning a few words from a rendered document and using them to find the electronic original from which the document was printed. Often, the number of words required to uniquely identify a document is small, but sometimes the same phrase may occur in several documents and the results of the identification are ambiguous. It is then that context information can be brought to bear.

For example, if the same phrase occurs in a recent edition of the Washington Post and also in the Times of India, but the user is known to be in North America, the Washington Post article is much more likely to be the correct one. If the article occurred in the Washington Post within the last few days, and the candidate from the Times of India was from 18 months ago, then the probability of the Washington Post being the source again rises substantially. Lastly, if it is also known that the user has captured several articles from the Washington Post in the past but has never captured anything from the Times of India, then the system can be almost certain that the former is the correct source, and can act accordingly.

In this example, if each bit of contextual knowledge increases the probability that the capture came from the Washington Post by a factor of ten—probably a rather conservative estimate for these examples—the combination of the three increases by a factor of 1000 the probability that a system which incorporates them, and thus presents options to the user based on the origin being the Washington Post, will

be making a correct decision on behalf of the user when compared to a system which ignores such factors.

A second example of the use of context to identify the electronic counterpart of a document comes from deducing that two or more captures probably came from the same document. The system may do this by observing that they were close together in time, that they captured text in the same language, color, or font, or from the same type of paper, or any combination of these and similar factors.

Without taking context into account, the accuracy with which a document can be identified depends on the amount of text captured and the contents of that text. In an example experiment, the following table lists the number of documents containing the specified phrases as reported by the Google search engine:

TABLE 1

Phrase	Approx number of hits
“on a dark”	220,000
“on a dark evening”	1,030
“on a dark evening when”	15
“on a dark evening when she”	1

Thus in many cases, without the use of context, the system can identify the document uniquely simply by requiring the user to capture a long-enough phrase. This may be inconvenient, however, since in some cases the length of phrase required may run to more than can conveniently be captured in a single scan. In addition, the user may be capturing several phrases from a document to indicate his interest in them, and those phrases may often be quite short. Longer passages, as well as being inconvenient to capture, may not identify the topic of interest as clearly as the short phrases.

In some embodiments, the system uses contextual information to deduce that two successive captures came from the same document, for example because they occur very close together in time. This may allow the identification of the document based on combinations of shorter phrases. The same unique document identified in Table 1 above, for example, may be identified by two much shorter phrases occurring separately in the document:

TABLE 2

Phrase	Number of hits
“nokia 3310”	676,000
“a dark evening”	750
“a dark evening” and “nokia 3310”	1

It will also be apparent that once the context of the scan has been established in this way, there can be no doubt about the source of any additional captures from the same document, even if they are single words, except where those words occur more than once in that document. Even then, a great deal can be deduced from the order in which the captures occur, as words which are captured later are likely to occur later in the document.

In some embodiments, the capture process is less precise—for example, due to the possibility of recognition errors—or the search process less exact. The establishment of the electronic counterpart then becomes a matter of pure statistical probabilities rather than being partially based on the exact matching of a search pattern. In some such embodiments, the system considers contextual factors to help improve the statistical certainty at all stages of this process. The system, for

example, is informed to consider both the French and the English dictionaries if the English-speaking user is known to be in France.

Tailoring the Content and Activities Available to a User

In some embodiments, the system also uses context to select the content and the options available to the user of a system.

As an example, a user capturing some text from a book may, as a result of markup associated with that book, be offered the option to purchase a copy of the book from an online retailer. If the system can determine, through examining his previous captures, that the user is a regular reader of a particular publication, it may offer him a special discount price available to subscribers of that publication. If, on the other hand, the system can determine that the user is in a country to which the retailer has no shipping facilities, the system need not offer him the option of purchasing from that retailer.

In some embodiments, the system achieves such control through the use of context conditions included in the markup that must be met for the markup to be valid or relevant. A review of a theater performance, for example, may have markup associated with it which causes the system to offer the user a link to a web site selling tickets to the play. This markup may have an associated context condition which specifies that the link is to be offered only before Jun. 30, 2005, the date at which the performances cease, since offering this option to the user after this time would be unhelpful.

Similarly, in certain contexts, the system restricts the range of activities available to a particular user for security or other similar reasons. An example is in the use of the system as a copying device. A user may carry a scanning device that enables him to capture phrases from documents and also store electronic copies of the documents containing the captures. In some environments where copying of the data is restricted, for example in secure military establishments, the system restricts or disallows use of the device based upon contextual information. In some embodiments, the scanner device is designed to operate in daylight or under conventional electric light; fluorescent lighting of a particular frequency is installed in situations where operation of the scanner device is not allowed; and the device refuses to function under such lighting conditions.

Tailoring the Presentation of the System

Another way that the system uses context is to present system output in a way that is most appropriate for the user's activities and situation. At the level of the immediate capture context, in some embodiments, the system does little more than prompt the user to resolve ambiguities about documents using a menu that is ordered based on his recent use of documents. At the level of the user context, in some embodiments, a capture device that is integrated with a mobile phone detects that a user is traveling in a car and prompts him—using voice prompts as well as graphical menus—to reduce distraction in the event that he is driving.

In some embodiments, the system provides direct feedback to the user about the state of the context analysis process. For example, the device can provide an indication that it has concluded that the user is in the same document as the previous capture, or that it has gathered enough information to be certain of the current capture context.

Proactive Prediction

In some embodiments, the system predicts a change of context in the future, typically by the use of past and present context. For example, in some embodiments, capture devices have substantial caching facilities to improve their performance in general and to allow them to function usefully when

offline (see section 15.3). For such devices, the user's context is an important input in the decision about what to cache and when. A user who habitually reads the paper on the 7:30 train to work is likely to appreciate a system that has pre-cached the index for that day's paper before he starts the journey. A user who has spent an hour in the departure lounge of an international airport is likely to be offline for some hours and would benefit from the cache being updated before the flight. This user is also less likely to be capturing information from the local newspaper for the next few days, thus allowing space used by indices from that paper to be freed up.

Implementation Examples

As a simple example implementation, this section considers the use of context to prioritize and disambiguate documents in the case where a capture may have occurred from more than one source.

Use of Context in the Selection of Candidates

In a traditional text-based query, which is used to search for matching documents in a corpus, there may be many candidate documents that contain the query terms (the words or phrases used in the search). In some embodiments, there can be uncertainty about the precision of the text recognition process, meaning that there may be extra candidate words in the query with associated probabilities of accuracy, also adding to the numbers of candidate matching documents. These candidates may be considered to be located in a multi-dimensional search "space." The dimensions of the space are based on the query terms used. The system uses the proximity in this space of each of the candidate documents to the query to prioritize the search results and identify the most likely candidates. The system bases the scaling of the dimensions, the weighting of the terms and the method of calculating proximity on such factors as the frequency of the terms in the normal use of the language and their frequency in the candidate document relative to the size of the document.

In some embodiments, the system uses context as an extra set of dimensions in this space. As an example, the system may use the fact that a document that has been recently scanned is more likely to be the source of the current scan, especially if the scan is within the last few minutes. The system therefore positions each candidate document in the time dimension based on the closest time a capture was made from it. The system positions the query (associated with the "current" capture) based on the time at which the capture occurred. The system places any documents from which a capture has never been made or for which that capture was more than X hours from the time of the current capture in the space at a distance of X hours away from the current capture. Thus, the system will consider any documents from which a capture has been made within X hours of the current capture more likely candidates than the others, and, all other factors being equal, will consider those closest in time the most likely.

In some embodiments, the system constructs a similar dimension for "time of day," where positioning in that dimension is based on the time within the 24-hour clock at which captures occur. Thus, documents that are habitually scanned between 8 and 9 a.m. are more likely to be recognized as matches for other scans occurring in that period.

In some cases the distance metric in a particular dimension will be specific to that dimension. In some dimensions they will be non-linear. In the "time of day" example they may need to wrap around so that 23:59:59 (pm) is very close to 00:00:00 (am).

Context as a Second Stage

In some embodiments, the system identifies candidate documents based upon which documents match or fail to match the captured text. The system automatically excludes documents that fail to match. In this case, the system uses context to prioritize the documents after it has identified the matching candidates.

The Use of Document Type

In some embodiments, the system considers documents based upon their type. For example, if a capture made late at night produces two candidate source documents, one of which is a novel and the other a TV guide, and the system knows that previous captures by the user at that time of night have always been from novels, then the system gives the novel a higher priority. In some embodiments, the system considers proximity to documents of a similar type, such as by using standard clustering techniques.

CONCLUSION

It will be appreciated by those skilled in the art that the above-described system may be straightforwardly adapted or extended in various ways. While the foregoing description makes reference to particular embodiments, the scope of the invention is defined solely by the claims that follow and the elements recited therein.

We claim:

1. A method in a computing system having a processor for processing a distinguished text capture operation, comprising:

receiving text captured from a distinguished rendered document in the distinguished text capture operation; receiving supplemental information distinct from the captured text; and

with the processor, determining an action to perform in response to the distinguished text capture operation based upon both the captured text and the supplemental information,

wherein the distinguished text capture operation is performed by a distinguished user, and

wherein the received supplemental information includes a document rendering characteristic observed in a previous text capture operation by the distinguished user and a corresponding document rendering characteristic observed in the distinguished text capture operation, and wherein the determined action is identifying different electronic documents as corresponding to the rendered documents in which the distinguished text capture operation and the previous text capture operation were performed based upon a difference between the document rendering characteristic observed in the previous text capture operation and the corresponding document rendering characteristic observed in the distinguished text capture operation.

2. The method of claim 1 wherein the received captured text is captured from a printed document.

3. The method of claim 1, further comprising applying optical character recognition techniques to an image captured from the distinguished rendered document to generate the captured text.

4. The method of claim 1, further comprising applying voice recognition techniques to an audio clip of a person reading aloud from the distinguished rendered document to generate the captured text.

5. The method of claim 1

wherein the distinguished text capture operation is performed by a distinguished user, and

wherein the received supplemental information includes text captured in previous text capture operations by the distinguished user, and

wherein the determined action is identifying a single electronic document as corresponding to the distinguished rendered document.

6. The method of claim 1 wherein the document rendering characteristic observed in the previous text capture operation and the corresponding document rendering characteristic observed in the distinguished text capture operation are different fonts.

7. The method of claim 1 wherein the document rendering characteristic observed in the previous text capture operation and the corresponding document rendering characteristic observed in the distinguished text capture operation are different font sizes.

8. The method of claim 1 wherein the document rendering characteristic observed in the previous text capture operation and the corresponding document rendering characteristic observed in the distinguished text capture operation are different paper types.

9. The method of claim 1 wherein the determined action is identifying a position in a distinguished electronic document that is subsequent to a position identified in the distinguished electronic document as the site of a previous text capture operation by the distinguished user as the site of the distinguished text capture operation.

10. The method of claim 1 wherein the received supplemental information indicates a geographic location at which the distinguished capture operation was performed, and wherein the determining comprises:

identifying a plurality of electronic documents containing the received captured text; and

ranking the likelihood of the identified electronic documents corresponding to the distinguished rendered document based upon the likelihood that a rendered version of each identified electronic document would be available in the indicated geographic location.

11. The method of claim 1, further comprising using the received captured text to identify an electronic document corresponding to the distinguished rendered document, wherein the received supplemental information indicates a geographic location at which rendered copies of the identified electronic document are likely to be available, and wherein the determining comprises determining that the text capture operation was performed at the indicated geographic location.

12. The method of claim 1 wherein the distinguished text capture operation is performed using a text capture device, and wherein the received supplemental information includes information about an ambient environment in which the distinguished text capture operation was performed, and wherein the determining comprises determining a configuration of a distinguished capability of the device.

13. The method of claim 12 wherein the distinguished text capture operation involves capturing an image of the captured text from the distinguished rendered document, and wherein the received supplemental information includes an indication of a frequency of light received in the image capture.

14. The method of claim 12 wherein the distinguished text capture operation involves capturing an audio clip of a person reading aloud from the distinguished rendered document, and wherein the received supplemental information includes an indication of background sounds contained in the audio clip.

15. The method of claim 13 wherein determining a configuration of a distinguished capability of the device comprises determining to disable the distinguished capability.

55

16. The method of claim 1 wherein the received supplemental information includes an indication of a time of day at which the distinguished image capture operation was performed, and wherein the determined action is identifying a single electronic document as corresponding to the distinguished rendered document.

17. The method of claim 1 wherein the received supplemental information includes an indication of a day of week at which the distinguished image capture operation was performed, and wherein the determined action is identifying a single electronic document as corresponding to the distinguished rendered document.

18. The method of claim 1 wherein the distinguished text capture operation is performed by a distinguished user, and wherein the received supplemental information includes an indication of recent interactions of the distinguished user with electronic documents, and wherein the determined action is identifying a single electronic document as corresponding to the distinguished rendered document.

19. The method of claim 18 wherein the received supplemental information identifies documents that the distinguished user has recently loaded.

20. A computer-readable recording medium having contents configured to cause a computing system having a processor to perform operations of processing a distinguished text capture operation, the operations comprising:

receiving text captured from a distinguished rendered document in the distinguished text capture operation; receiving supplemental information distinct from the captured text; and

with the processor, determining an action to perform in response to the distinguished text capture operation based upon both the captured text and the supplemental information,

wherein the distinguished text capture operation is performed by a distinguished user, and wherein the received supplemental information includes a document rendering characteristic observed in a previous text capture operation by the distinguished user and a corresponding document rendering characteristic observed in the distinguished text capture operation, and wherein the determined action is identifying different electronic documents as corresponding to the rendered documents in which the distinguished text capture operation and the previous text capture operation were performed based upon a difference between the document rendering characteristic observed in the previous text capture operation and the corresponding document rendering characteristic observed in the distinguished text capture operation.

21. A computer-readable recording medium having contents configured to cause a computing system having a processor to perform operations of processing a distinguished text capture operation, the operations comprising:

receiving text captured from a distinguished rendered document in the distinguished text capture operation; receiving supplemental information distinct from the captured text; and

with the processor, determining an action to perform in response to the distinguished text capture operation based upon both the captured text and the supplemental information,

wherein the received supplemental information indicates a geographic location at which the distinguished capture operation was performed, and wherein the determining comprises: identifying a plurality of electronic documents containing the received captured text; and ranking the likelihood of the identified electronic documents corresponding to the distinguished rendered

56

document based upon the likelihood that a rendered version of each identified electronic document would be available in the indicated geographic location.

22. The computer-readable medium of claim 21 wherein the received captured text is captured from a printed document.

23. The computer-readable medium of claim 21, wherein the operations further comprises applying optical character recognition techniques to an image captured from the distinguished rendered document to generate the captured text.

24. The computer-readable medium of claim 21, wherein the set of functions further comprises applying voice recognition techniques to an audio clip of a person reading aloud from the distinguished rendered document to generate the captured text.

25. The computer-readable medium of claim 21 wherein the distinguished text capture operation is performed by a distinguished user, and wherein the received supplemental information includes text captured in previous text capture operations by the distinguished user, and wherein the determined action is identifying a single electronic document as corresponding to the distinguished rendered document.

26. The computer-readable medium of claim 21 wherein the distinguished text capture operation is performed by a distinguished user, and wherein the received supplemental information includes a document rendering characteristic observed in a previous text capture operation by the distinguished user and a corresponding document rendering characteristic observed in the distinguished text capture operation, and wherein the determined action is identifying different electronic documents as corresponding to the rendered documents in which the distinguished text capture operation and the previous text capture operation were performed based upon a difference between the document rendering characteristic observed in the previous text capture operation and the corresponding document rendering characteristic observed in the distinguished text capture operation.

27. The computer-readable medium of claim 26 wherein the document rendering characteristic observed in the previous text capture operation and the corresponding document rendering characteristic observed in the distinguished text capture operation are different fonts.

28. The computer-readable medium of claim 26 wherein the document rendering characteristic observed in the previous text capture operation and the corresponding document rendering characteristic observed in the distinguished text capture operation are different font sizes.

29. The computer-readable medium of claim 26 wherein the document rendering characteristic observed in the previous text capture operation and the corresponding document rendering characteristic observed in the distinguished text capture operation are different paper types.

30. The computer-readable medium of claim 21 wherein the determined action is identifying a position in a distinguished electronic document that is subsequent to a position identified in the distinguished electronic document as the site of a previous text capture operation by the distinguished user as the site of the distinguished text capture operation.

31. The computer-readable medium of claim 21, wherein the operations further comprises using the received captured text to identify an electronic document corresponding to the distinguished rendered document, wherein the received supplemental information indicates a geographic location at which rendered copies of the identified electronic document are likely to be available, and wherein the determining comprises determining that the text capture operation was performed at the indicated geographic location.

32. The computer-readable medium of claim 21 wherein the distinguished text capture operation is performed using a text capture device, and wherein the received supplemental information includes information about an ambient environment in which the distinguished text capture operation was performed, and wherein the determining comprises determining a configuration of a distinguished capability of the device.

33. The computer-readable medium of claim 32 wherein the distinguished text capture operation involves capturing an image of the captured text from the distinguished rendered document, and wherein the received supplemental information includes an indication of a frequency of light received in the image capture.

34. The computer-readable medium of claim 32 wherein the distinguished text capture operation involves capturing an audio clip of a person reading aloud from the distinguished rendered document, and wherein the received supplemental information includes an indication of background sounds contained in the audio clip.

35. The computer-readable medium of claim 32 wherein determining a configuration of a distinguished capability of the device comprises determining to disable the distinguished capability.

36. The computer-readable medium of claim 21 wherein the received supplemental information includes an indication of a time of day at which the distinguished image capture operation was performed, and the determined action is identifying a single electronic document as corresponding to the distinguished rendered document.

37. The computer-readable medium of claim 21 wherein the received supplemental information includes an indication of a day of week at which the distinguished image capture operation was performed, and wherein the determined action is identifying a single electronic document as corresponding to the distinguished rendered document.

38. The computer-readable medium of claim 21 wherein the distinguished text capture operation is performed by a distinguished user, and wherein the received supplemental information includes an indication of recent interactions of the distinguished user with electronic documents, and wherein the determined action is identifying a single electronic document as corresponding to the distinguished rendered document.

39. The computer-readable medium of claim 38 wherein the received supplemental information identifies documents that the distinguished user has recently loaded.

40. A method in a computing system having a processor for processing a distinguished text capture operation, comprising:

receiving text captured from a distinguished rendered document in the distinguished text capture operation; receiving supplemental information distinct from the captured text; and

with the processor, determining an action to perform in response to the distinguished text capture operation based upon both the captured text and the supplemental information,

wherein the distinguished text capture operation is performed by a distinguished user, and wherein the received supplemental information includes a document rendering characteristic observed in a previous text capture operation by the distinguished user and a corresponding document rendering characteristic observed in the distinguished text capture operation, and wherein the determined action is identifying different electronic documents as corresponding to the rendered documents in which the distinguished text capture operation and the previous text capture operation were per-

formed based upon a difference between the document rendering characteristic observed in the previous text capture operation and the corresponding document rendering characteristic observed in the distinguished text capture operation.

41. A method in a computing system having a processor for processing a distinguished text capture operation, comprising:

receiving text captured from a distinguished rendered document in the distinguished text capture operation;

receiving supplemental information distinct from the captured text; and

with the processor, determining an action to perform in response to the distinguished text capture operation based upon both the captured text and the supplemental information,

wherein the distinguished text capture operation is performed using a text capture device, and wherein the received supplemental information includes information about an ambient environment in which the distinguished text capture operation was performed, and wherein the determining comprises determining a configuration of a distinguished capability of the device.

42. The method of claim 41 wherein the received captured text is captured from a printed document.

43. The method of claim 41, further comprising applying optical character recognition techniques to an image captured from the distinguished rendered document to generate the captured text.

44. The method of claim 41, further comprising applying voice recognition techniques to an audio clip of a person reading aloud from the distinguished rendered document to generate the captured text.

45. The method of claim 41 wherein the distinguished text capture operation is performed by a distinguished user, and wherein the received supplemental information includes text captured in previous text capture operations by the distinguished user, and wherein the determined action is identifying a single electronic document as corresponding to the distinguished rendered document.

46. The method of claim 41 wherein the distinguished text capture operation is performed by a distinguished user, and wherein the received supplemental information includes a document rendering characteristic observed in a previous text capture operation by the distinguished user and a corresponding document rendering characteristic observed in the distinguished text capture operation, and wherein the determined action is identifying different electronic documents as corresponding to the rendered documents in which the distinguished text capture operation and the previous text capture operation were performed based upon a difference between the document rendering characteristic observed in the previous text capture operation and the corresponding document rendering characteristic observed in the distinguished text capture operation.

47. The method of claim 46 wherein the document rendering characteristic observed in the previous text capture operation and the corresponding document rendering characteristic observed in the distinguished text capture operation are different fonts.

48. The method of claim 46 wherein the document rendering characteristic observed in the previous text capture operation and the corresponding document rendering characteristic observed in the distinguished text capture operation are different font sizes.

49. The method of claim 46 wherein the document rendering characteristic observed in the previous text capture operation

59

tion and the corresponding document rendering characteristic observed in the distinguished text capture operation are different paper types.

50. The method of claim 41 wherein the determined action is identifying a position in a distinguished electronic document that is subsequent to a position identified in the distinguished electronic document as the site of a previous text capture operation by the distinguished user as the site of the distinguished text capture operation.

51. The method of claim 41 wherein the received supplemental information indicates a geographic location at which the distinguished capture operation was performed, and wherein the determining comprises:

identifying a plurality of electronic documents containing the received captured text; and

ranking the likelihood of the identified electronic documents corresponding to the distinguished rendered document based upon the likelihood that a rendered version of each identified electronic document would be available in the indicated geographic location.

52. The method of claim 41, further comprising using the received captured text to identify an electronic document corresponding to the distinguished rendered document, wherein the received supplemental information indicates a geographic location at which rendered copies of the identified electronic document are likely to be available, and wherein the determining comprises determining that the text capture operation was performed at the indicated geographic location.

53. The method of claim 41 wherein the distinguished text capture operation involves capturing an image of the captured text from the distinguished rendered document, and wherein the received supplemental information includes an indication of a frequency of light received in the image capture.

54. The method of claim 41 wherein the distinguished text capture operation involves capturing an audio clip of a person reading aloud from the distinguished rendered document, and wherein the received supplemental information includes an indication of background sounds contained in the audio clip.

55. The method of claim 41 wherein determining a configuration of a distinguished capability of the device comprises determining to disable the distinguished capability.

60

56. The method of claim 41 wherein the received supplemental information includes an indication of a time of day at which the distinguished image capture operation was performed, and the determined action is identifying a single electronic document as corresponding to the distinguished rendered document.

57. The method of claim 41 wherein the received supplemental information includes an indication of a day of week at which the distinguished image capture operation was performed, and wherein the determined action is identifying a single electronic document as corresponding to the distinguished rendered document.

58. The method of claim 41 wherein the distinguished text capture operation is performed by a distinguished user, and wherein the received supplemental information includes an indication of recent interactions of the distinguished user with electronic documents, and wherein the determined action is identifying a single electronic document as corresponding to the distinguished rendered document.

59. The method of claim 41 wherein the received supplemental information identifies documents that the distinguished user has recently loaded.

60. A computer-readable recording medium having contents configured to cause a computing system having a processor to perform operations of processing a distinguished text capture operation, the operations comprising:

receiving text captured from a distinguished rendered document in the distinguished text capture operation; receiving supplemental information distinct from the captured text; and

with the processor, determining an action to perform in response to the distinguished text capture operation based upon both the captured text and the supplemental information,

wherein the distinguished text capture operation is performed using a text capture device, and wherein the received supplemental information includes information about an ambient environment in which the distinguished text capture operation was performed, and wherein the determining comprises determining a configuration of a distinguished capability of the device.

* * * * *