

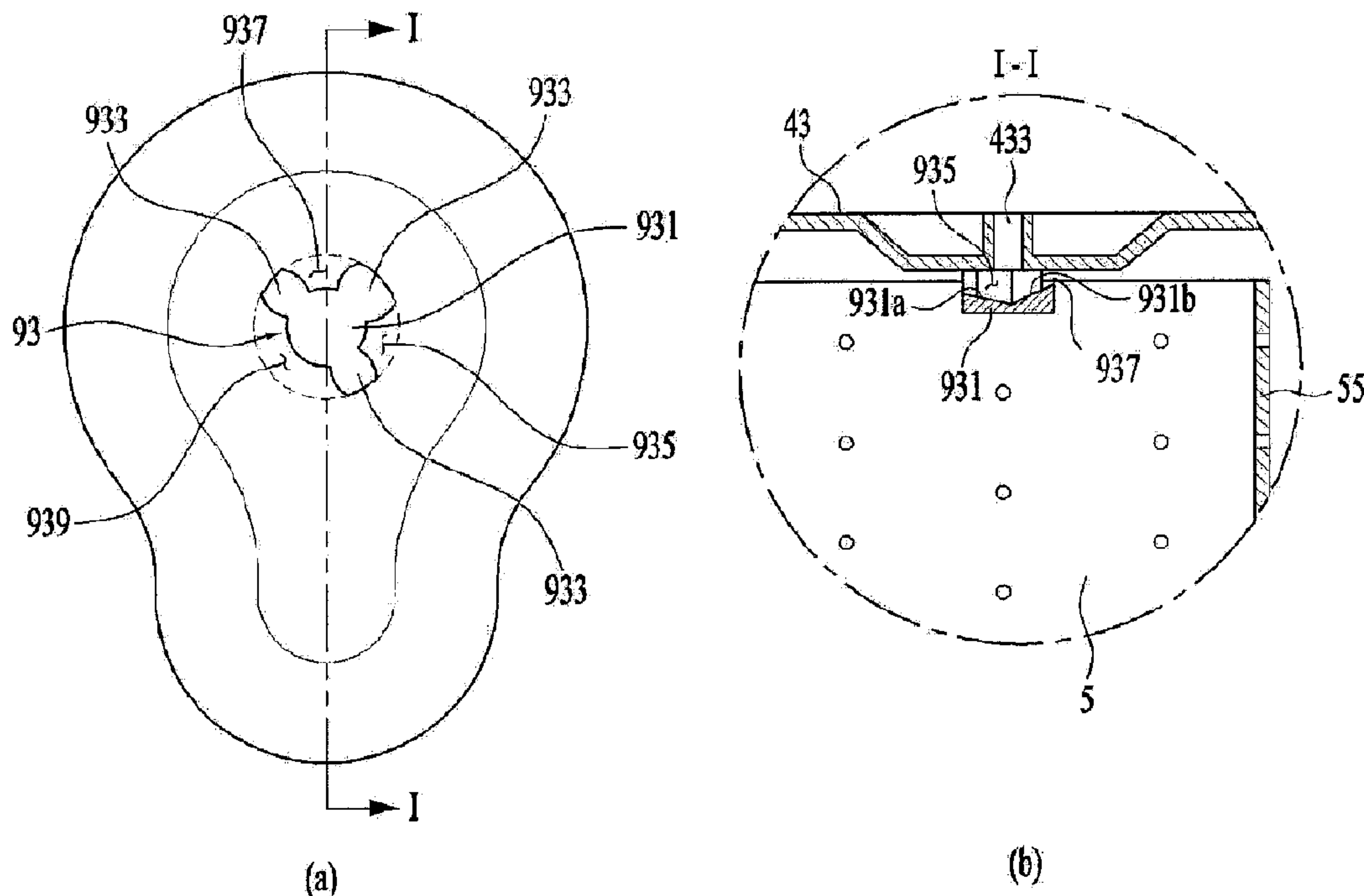

(86) **Date de dépôt PCT/PCT Filing Date:** 2016/06/30
 (87) **Date publication PCT/PCT Publication Date:** 2017/01/05
 (45) **Date de délivrance/Issue Date:** 2019/09/24
 (85) **Entrée phase nationale/National Entry:** 2017/01/25
 (86) **N° demande PCT/PCT Application No.:** KR 2016/007025
 (87) **N° publication PCT/PCT Publication No.:** 2017/003213
 (30) **Priorité/Priority:** 2015/06/30 (KR10-2015-0092773)

(51) **Cl.Int./Int.Cl. D06F 37/00** (2006.01),
D06F 37/26 (2006.01), **D06F 39/12** (2006.01)
 (72) **Inventeurs/Inventors:**
 JEONG, KWANWOONG, KR;
 NO, YANGHWAN, KR;
 LEE, CHANHO, KR;
 LEE, JIHONG, KR
 (73) **Propriétaire/Owner:**
 LG ELECTRONICS INC., KR
 (74) **Agent:** SMART & BIGGAR

(54) **Titre : APPAREIL DE TRAITEMENT DE LINGE**
 (54) **Title: LAUNDRY TREATMENT APPARATUS**



(57) **Abrégé/Abstract:**

Disclosed is a laundry treatment apparatus including a tub body for storing water therein, a tub cover for forming the upper surface of the tub body, an introduction aperture formed through the tub cover, a drum rotatably provided in the tub body for storing laundry therein, the drum having an opening communicating with the introduction aperture, a rotating shaft for rotating the drum, the rotating shaft being orthogonal to the bottom surface of the tub body, a door for opening and closing the introduction aperture, and an ejection unit for ejecting at least some of water moved toward the tub cover to the door using the centrifugal force generated while the drum is rotated.

(12) INTERNATIONAL APPLICATION PUBLISHED UNDER THE PATENT COOPERATION TREATY (PCT)

(19) World Intellectual Property
Organization
International Bureau(10) International Publication Number
WO 2017/003213 A1(43) International Publication Date
5 January 2017 (05.01.2017)

- (51) **International Patent Classification:**
D06F 37/26 (2006.01) *D06F 39/12* (2006.01)
- (21) **International Application Number:**
PCT/KR2016/007025
- (22) **International Filing Date:**
30 June 2016 (30.06.2016)
- (25) **Filing Language:** English
- (26) **Publication Language:** English
- (30) **Priority Data:**
10-2015-0092773 30 June 2015 (30.06.2015) KR
- (71) **Applicant:** LG ELECTRONICS INC. [KR/KR]; 128, Yeoui-daero, Yeongdeungpo-gu, Seoul 07336 (KR).
- (72) **Inventors:** JEONG, Kwanwoong; IP Center, LG Electronics Inc., 51, Gasan digital 1-ro, Geumcheon-gu, Seoul 08592 (KR). NO, Yanghwan; IP Center, LG Electronics Inc., 51, Gasan digital 1-ro, Geumcheon-gu, Seoul 08592 (KR). LEE, Chanho; IP Center, LG Electronics Inc., 51, Gasan digital 1-ro, Geumcheon-gu, Seoul 08592 (KR). LEE, Jihong; IP Center, LG Electronics Inc., 51, Gasan digital 1-ro, Geumcheon-gu, Seoul 08592 (KR).
- (74) **Agents:** KIM, Yong In et al.; KBK & Associates, 7th Floor, 82, Olympic-ro, Songpa-ku, Seoul 05556 (KR).

- (81) **Designated States** (*unless otherwise indicated, for every kind of national protection available*): AE, AG, AL, AM, AO, AT, AU, AZ, BA, BB, BG, BH, BN, BR, BW, BY, BZ, CA, CH, CL, CN, CO, CR, CU, CZ, DE, DK, DM, DO, DZ, EC, EE, EG, ES, FI, GB, GD, GE, GH, GM, GT, HN, HR, HU, ID, IL, IN, IR, IS, JP, KE, KG, KN, KP, KZ, LA, LC, LK, LR, LS, LU, LY, MA, MD, ME, MG, MK, MN, MW, MX, MY, MZ, NA, NG, NI, NO, NZ, OM, PA, PE, PG, PH, PL, PT, QA, RO, RS, RU, RW, SA, SC, SD, SE, SG, SK, SL, SM, ST, SV, SY, TH, TJ, TM, TN, TR, TT, TZ, UA, UG, US, UZ, VC, VN, ZA, ZM, ZW.
- (84) **Designated States** (*unless otherwise indicated, for every kind of regional protection available*): ARIPO (BW, GH, GM, KE, LR, LS, MW, MZ, NA, RW, SD, SL, ST, SZ, TZ, UG, ZM, ZW), Eurasian (AM, AZ, BY, KG, KZ, RU, TJ, TM), European (AL, AT, BE, BG, CH, CY, CZ, DE, DK, EE, ES, FI, FR, GB, GR, HR, HU, IE, IS, IT, LT, LU, LV, MC, MK, MT, NL, NO, PL, PT, RO, RS, SE, SI, SK, SM, TR), OAPI (BF, BJ, CF, CG, CI, CM, GA, GN, GQ, GW, KM, ML, MR, NE, SN, TD, TG).

Published:

— with international search report (Art. 21(3))

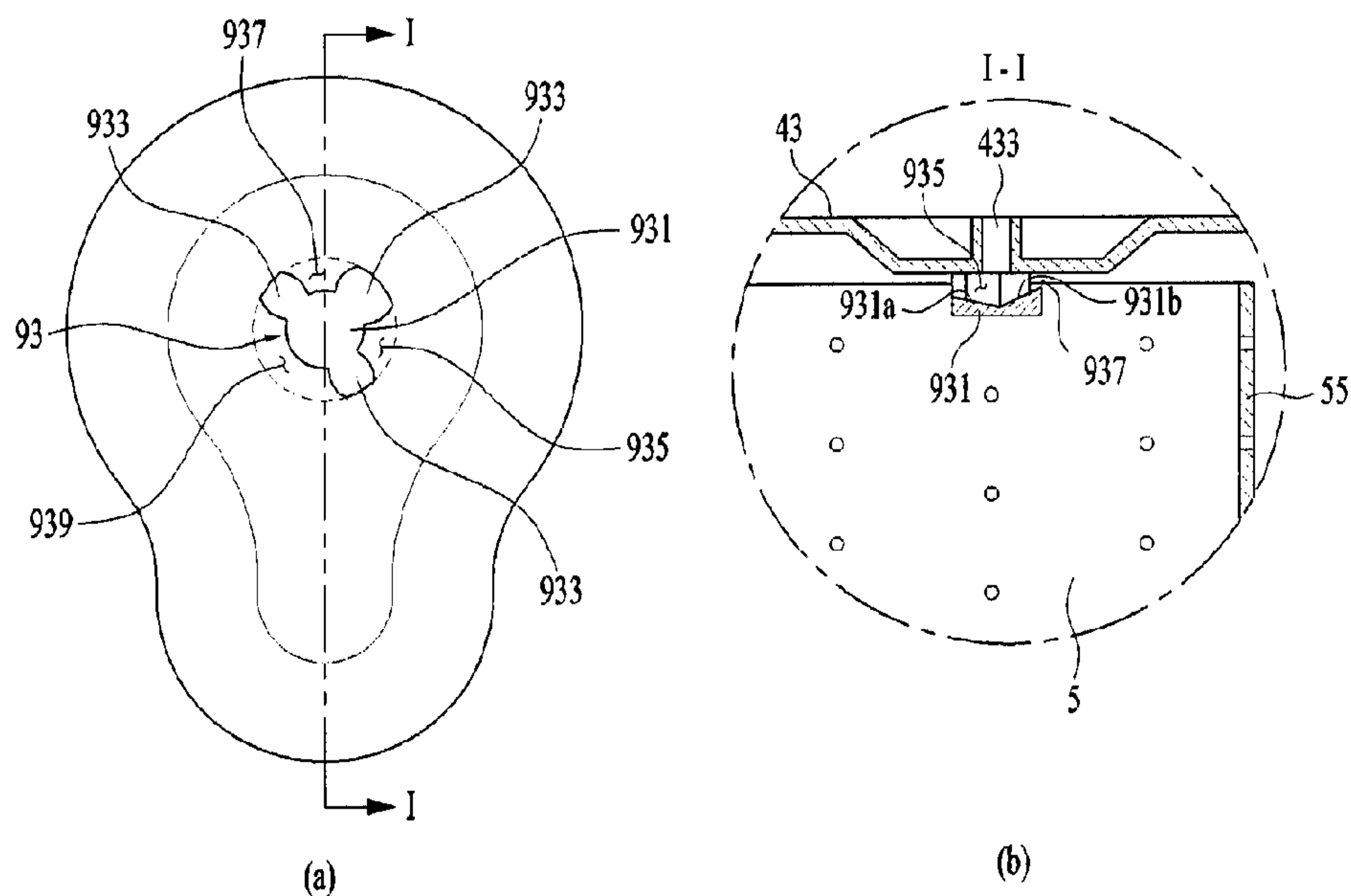
(54) **Title:** LAUNDRY TREATMENT APPARATUS

(57) **Abstract:** Disclosed is a laundry treatment apparatus including a tub body for storing water therein, a tub cover for forming the upper surface of the tub body, an introduction aperture formed through the tub cover, a drum rotatably provided in the tub body for storing laundry therein, the drum having an opening communicating with the introduction aperture, a rotating shaft for rotating the drum, the rotating shaft being orthogonal to the bottom surface of the tub body, a door for opening and closing the introduction aperture, and an ejection unit for ejecting at least some of water moved toward the tub cover to the door using the centrifugal force generated while the drum is rotated.

WO 2017/003213 A1

Description

Title of Invention: LAUNDRY TREATMENT APPARATUS

Technical Field

- [1] The present invention relates to a laundry treatment apparatus.

Background Art

- [2] Generally, a laundry treatment apparatus is a generic term for an apparatus that washes laundry (e.g., objects to be washed or objects to be dried), an apparatus that dries laundry, and an apparatus that may perform both washing and drying of laundry.
- [3] Conventional laundry treatment apparatuses are classified into front loading type laundry treatment apparatuses which are configured such that laundry is introduced through an introduction aperture formed in the front surface of the apparatus, and top loading type laundry treatment apparatuses which are configured such that laundry is introduced through an introduction aperture formed in the upper surface of the apparatus.
- [4] A top loading type laundry treatment apparatus includes a tub having an introduction aperture formed in the upper surface of the apparatus, a drum rotatably provided inside the tub, and a door for opening and closing the introduction aperture.
- [5] Some conventional laundry treatment apparatuses having the configuration described above are devised to have a minimum volume in order to wash only a very small amount of laundry. Such a laundry treatment apparatus having a minimum volume has the feature of a very small distance between the introduction aperture and the upper end of the drum.
- [6] In addition, in the case in which the laundry treatment apparatus is an auxiliary laundry treatment apparatus that is coupled to a main laundry treatment apparatus, which performs main washing, the volume of the laundry treatment apparatus is restricted, with the result that the distance between the introduction aperture and the upper end of the drum is very small.
- [7] In addition, in the case in which the main laundry treatment apparatus is a top loading type laundry treatment apparatus, a front loading type auxiliary laundry treatment apparatus may be provided under the main laundry treatment apparatus. In this case, the auxiliary laundry treatment apparatus may be a drawer type laundry treatment apparatus, which may be configured to be discharged forward. Because the height of the auxiliary laundry treatment apparatus is less than the height of a conventional top loading type laundry treatment apparatus, the heights of the tub and the drum in the auxiliary laundry treatment apparatus are less than the heights of the tub and the drum in the conventional top loading type laundry treatment apparatus.

[8] Therefore, impurities, which are generated inside the tub when the drum is rotated to wash laundry, remain on the door.

[9] That is, because a water stream is generated inside the tub while the drum is rotated, there is the possibility that bubbles, which are generated as the detergent is dissolved, or contaminants discharged from the laundry during washing may remain on the door or inside the drum after the washing is completed.

[10] When the bubbles or contaminants remain on the inner surface of the door or on the circumferential surface of the drum despite the completion of washing, a user may erroneously determine that the washing of laundry is not completed or may suspect the failure of the laundry treatment apparatus.

[11] In addition, bubbles or impurities generated during washing of laundry may remain on the door, with the result that the bubbles or the impurities may be stuck to the laundry after the washing is completed, thereby reducing washing efficiency.

[12]

Disclosure of Invention

Technical Problem

[13] Accordingly, the present invention is directed to a laundry treatment apparatus that substantially obviates one or more in problems due to limitations and disadvantages of the related art.

[14] One object of the present invention is to provide a laundry treatment apparatus, which may prevent impurities, generated inside a tub during washing, from remaining on a door, which is used to open and close an introduction aperture.

[15] In addition, another object of the present invention is to provide a laundry treatment apparatus, which may wash a door using the centrifugal force generated by the water stored in a tub while a drum is rotated.

[16] In addition, another object of the present invention is to provide a laundry treatment apparatus, which may prevent bubbles or impurities from being stuck again to laundry when washing is completed.

[17] In addition, another object of the present invention is to provide a laundry treatment apparatus, which may remove bubbles or impurities from a door when washing is completed, thereby ensuring that a user does not doubt the ability of the laundry treatment apparatus.

[18]

Solution to Problem

[19] Additional advantages, objects, and features will be set forth in part in the description which follows and in part will become apparent to those having ordinary skill in the art upon examination of the following or may be learned from practice. The objectives and

other advantages may be realized and attained by the structure particularly pointed out in the written description and claims hereof as well as the appended drawings.

- [20] To achieve these objects and other advantages and in accordance with the purpose of the invention, as embodied and broadly described herein, in accordance with an aspect of the present invention, a laundry treatment apparatus includes a tub body for storing water therein, a tub cover for forming the upper surface of the tub body, an introduction aperture formed through the tub cover, a supply aperture provided in the tub cover for supplying water into the tub body, a drum rotatably provided in the tub body for storing laundry therein, the drum having an opening communicating with the introduction aperture, a door for opening and closing the introduction aperture, and an ejection unit for ejecting the water introduced into the supply aperture to the drum, wherein the ejection unit ejects water in at least two different directions.
- [21] The ejection unit may include an extension provided so as to surround the supply aperture, a body fixed to the extension so as to be spaced apart from the supply aperture by a predetermined distance, and at least two ejection holes formed through the extension for discharging water introduced into the extension.
- [22] The ejection unit may further include an inclined surface extending upward from the surface of the body toward the ejection holes.
- [23] The laundry treatment apparatus may further include a rotating shaft for rotating the drum and a washing unit for ejecting at least some of the water moved toward the tub cover to the door using the centrifugal force generated while the drum is rotated.
- [24] The ejection unit may be spaced apart from the center of rotation of the drum by a predetermined distance.
- [25] The washing unit may include a guide extending from the edge of the tub cover toward the introduction aperture and a discharge hole for discharging the water supplied through the guide in the direction in which the door is located.
- [26] The washing unit may further include a barrier protruding from the tub cover toward the upper surface of the drum, the barrier surrounding the edge of the introduction aperture, and the discharge hole may be formed through the barrier.
- [27] The door may be located above the introduction aperture, and the discharge hole may be inclined so as to discharge water toward the door.
- [28] The door may include a frame rotatably coupled to the tub cover and a window provided in the frame such that the inside of the tub body is visible from outside the tub body, and the discharge hole may be inclined so as to discharge water toward the window.
- [29] The guide may include a first guide for guiding water moved to the tub cover to the discharge hole when the drum is rotated in the clockwise direction and a second guide for guiding water moved to the tub cover to the discharge hole when the drum is

rotated in the counterclockwise direction.

- [30] The discharge hole may include a first discharge hole for discharging the water supplied through the first guide to the door and a second discharge hole for discharging the water supplied through the second guide to the door.
- [31] The first discharge hole and the second discharge hole may be inclined such that the path of water discharged from the first discharge hole and the path of water discharged from the second discharge hole cross each other.
- [32] The washing unit may include a plurality of washing units, at least two of the washing units being arranged so as to face each other.
- [33] The laundry treatment apparatus may further include a cabinet and a drawer provided so as to be discharged from the cabinet for supporting the tub body.
- [34] The laundry treatment apparatus may further include a rotating shaft for rotating the drum, the rotating shaft being orthogonal to the bottom surface of the tub body, wherein the door may include a frame rotatably coupled to the tub cover; a window provided in the frame such that the inside of the tub body is visible from outside the tub body; and a washing guide for guiding at least some of the water moved to the edge of the frame to the window using the centrifugal force generated while the drum is rotated.
- [35] In another aspect of the present invention, a laundry treatment apparatus includes a tub body for storing water therein, a tub cover for forming the upper surface of the tub body, an introduction aperture formed through the tub cover, a supply aperture provided in the tub cover for supplying water into the tub body, a drum rotatably provided in the tub body for storing laundry therein, the drum having an opening communicating with the introduction aperture, a door for opening and closing the introduction aperture, a rotating shaft for rotating the drum, the rotating shaft being orthogonal to the bottom surface of the tub body, and a washing unit for ejecting at least some of the water moved toward the tub cover to the door using the centrifugal force generated while the drum is rotated.
- [36] In a further aspect of the present invention, a laundry treatment apparatus includes a tub body for storing water therein, a tub cover for forming the upper surface of the tub body, an introduction aperture formed through the tub cover, a supply aperture provided in the tub cover for supplying water into the tub body, a drum rotatably provided in the tub body for storing laundry therein, the drum having an opening communicating with the introduction aperture, a door for opening and closing the introduction aperture, and a rotating shaft for rotating the drum, the rotating shaft being orthogonal to the bottom surface of the tub body, wherein the door includes a frame rotatably coupled to the tub cover, a window provided in the frame such that the inside of the tub body is visible from outside the tub body, and a washing guide for guiding at

least some of water moved to the edge of the frame to the window using centrifugal force generated while the drum is rotated.

[37] The ejection holes may include a first ejection hole formed through the extension, a second ejection hole spaced apart from the first ejection hole by a predetermined angle, and a third ejection hole spaced apart from the second ejection hole by a predetermined angle.

[38] The inclined surface may include a first inclined surface inclined upward from the body toward the first ejection hole, a second inclined surface inclined upward from the body toward the second ejection hole, and a third inclined surface inclined upward from the body toward the third ejection hole.

[39] The ejection unit may be spaced apart from the center of rotation of the drum by a predetermined distance.

[39a] Another aspect of the present disclosure provides a laundry treatment apparatus comprising: a tub body configured to store water; a tub cover configured to define an upper surface of the tub body; an introduction aperture defined through the tub cover; a supply aperture provided in the tub cover, and configured to enable supply of water into the tub body; a drum that is rotatably provided in the tub body, and that is configured to receive laundry, the drum including an opening in communication with the introduction aperture; a door configured to open and close the introduction aperture; an ejection unit that ejects water introduced into the supply aperture to the drum in at least two different directions; a rotating shaft configured to rotate the drum; and a washing unit that ejects at least some water moved toward the tub cover to the door using centrifugal force generated while the drum is rotated.

[40] It is to be understood that both the foregoing general description and the following detailed description of the present invention are exemplary and explanatory and are intended to provide further explanation of the present invention as claimed.

[41]

Advantageous Effects of Invention

[42] As is apparent from the above description, the present invention has the effect of providing a laundry treatment apparatus, which may prevent impurities, generated inside a tub during washing, from remaining on a door, which is used to open and close an introduction aperture.

[43] In addition, the present invention has the effect of providing a laundry treatment apparatus, which may wash a door using centrifugal force generated by water stored in a tub while a drum is rotated.

[44] In addition, the present invention has the effect of providing a laundry treatment apparatus, which may remove bubbles or impurities from a door when washing is completed, thereby ensuring that a user does not doubt the ability of the laundry treatment apparatus.

[45] In addition, the present invention has the effect of providing a laundry treatment apparatus, which may prevent bubbles or impurities from being stuck again to laundry when the bubbles or impurities have been removed from a door, i.e. when washing is completed, thereby preventing the reduction of washing performance.

[46]

Brief Description of Drawings

[47] FIGs. 1 and 2 are views illustrating an example of a laundry treatment apparatus;

[48] FIG. 3 is a view illustrating an example of the coupling relationship between a drawer, a tub, and a drum;

- [49] FIG. 4 is a view illustrating an example of a washing unit;
[50] FIG. 5 is a view illustrating an example of a washing guide and
[51] FIG. 6 is a view illustrating an example of an ejection unit.
[52]
[53]

Best Mode for Carrying out the Invention

- [54] As illustrated in FIGs. 1 and 2, a laundry treatment apparatus 100 may include a cabinet 2, a drawer 3 provided to be discharged from the cabinet 2, a tub 4 provided inside the drawer 3 for storing water therein, and a drum 5 rotatably provided inside the tub 4 for storing laundry therein.
- [55] The cabinet 2 may serve to define the external appearance of the laundry treatment apparatus 100, and may also simply serve as a space in which the drawer 3 is received. In any case, the cabinet 2 may be provided in the front surface of the laundry treatment apparatus with an opening 21 for the insertion of the drawer 3.
- [56] The drawer 3 includes a drawer body 31 configured to be inserted into the inside of the cabinet 2 through the opening 21, a drawer panel 33 fixed to the front surface of the drawer body 31 for opening and closing the opening 21, and a drawer cover 35 for forming the upper surface of the drawer body 31.
- [57] The drawer panel 33 is fixed to the front surface of the drawer body 31, and the drawer panel 33 may serve as a handle for discharging the drawer body 31 from the cabinet 2.
- [58] The drawer panel 33 may be provided with a control panel 331, which is used to input a control command associated with the operation of the laundry treatment apparatus 100, and to notify a user of a message associated with the operation of the laundry treatment apparatus 100.
- [59] The drawer body 31 may have any shape so long as it can be inserted into the cabinet 2 through the opening 21 and can provide a space in which the tub 4 is received. FIG. 1 illustrates a hollow drawer body 31 having a hexahedral shape by way of example.
- [60] The drawer cover 35 has a first through-hole 351 and a second through-hole 353 for communicating the inside of the drawer body 31 with the outside. The first through-hole 351 may be provided for the introduction and discharge of laundry, and the second through-hole 353 may be provided to supply water required to wash the laundry.
- [61] As illustrated in FIG. 2, the tub 4 includes a tub body 41 located inside the drawer body 31 for storing water therein, and a tub cover 43 for forming the upper surface of the tub body 41. The tub body 41 may take the form of a cylinder having an open upper surface. A heater 411 for heating water may be provided in the tub body 41.

- [62] The tub cover 43 may have an introduction aperture 431 for communicating the inside of the tub body 41 with the outside of the tub body 41, and a supply aperture 433 for introducing water into the tub body 41.
- [63] The introduction aperture 431 may be provided under the first through-hole 351 provided in the drawer cover 35, and the supply aperture 433 may be provided under the second through-hole 353 provided in the drawer cover 35.
- [64] The introduction aperture 431 serves to allow laundry to be introduced into the tub body 41, or serves to allow the laundry inside the tub body 41 to be discharged to the outside of the tub body 41. The introduction aperture 431 is opened and closed by a door 45.
- [65] As illustrated in FIG. 3, the door 45 may include a frame 451 rotatably coupled to the tub cover 43 via a hinge 453, a window 455 provided in the frame 451, and a door handle 457 for separably coupling the frame 451 to the tub cover 43. The window 455 may be formed of a transparent material to allow the user to view the inside of the tub body 41 when the drawer 3 is discharged from the cabinet 2.
- [66] In order to prevent the water inside the tub body 41 from being discharged to the outside of the tub body 41 through the introduction aperture 431, any one of the frame 451 and the tub cover 43 may be provided with a sealing unit 49 for hermetically sealing a space between the frame 451 and the introduction aperture 431 when the door 45 closes the introduction aperture 431.
- [67] The tub 4 is coupled to the drawer body 31 via a tub support unit 6. The tub support unit 6 may include a first support member 61 provided at the drawer body 31, a second support member 63 provided at the tub body 41, and a connector 65 for connecting the first support member 61 and the second support member 63 to each other.
- [68] The connector 65 may include a first connection piece 651 configured to be seated in the first support member 61, a second connection piece 653 for supporting the second support member 63, and a bar 655 for connecting the first connection piece 651, and the second connection piece 653 to each other.
- [69] The first connection piece 651 may be shaped to be movable in the first support member 61 while being seated in the first support member 61. The second connection piece 653 may be shaped to support the second support member 63 and to be movable in the second support member 63.
- [70] As illustrated in FIG. 2 the first connection piece 651 and the second connection piece 653 may have spherical shapes. As illustrated in FIG. 3 the first connection piece 651 and the second connection piece 653 may have semispherical surfaces in contact with the respective support members 61 and 63.
- [71] The bar 655 may form a right angle with respect to the bottom surface of the cabinet 2 (i.e. may be provided parallel to the height direction Z of the cabinet 2, or provided

to be orthogonal to the bottom surface of the drawer 3).

- [72] At least three tub support units 6 may be provided to couple the tub body 41 to the drawer body 31 and the bars 655 form a right angle with respect to the bottom surface of the cabinet 2, the distance between the tub cover 43 and the drawer cover 35 may be increased compared to the case where the bars 655 are tilted at a prescribed angle relative to the Z-axis.
- [73] Accordingly, the tub support units 6 may reduce the possibility of the tub cover 43 colliding with the drawer cover 35 even if the tub body 41 vibrates inside the drawer body 31.
- [74] When the bars 655 are provided to form a right angle with respect to the bottom surface of the drawer 3, at least one of the first support member 61 and the second support member 63 may be separably coupled to the drawer body 31.
- [75] When at least three tub support units 6 are provided, and both the first support member 61 and the second support member 63 are inseparable from the drawer body 31, a user who attempts to fix the tub body 41 to the drawer body 31 may firstly needs to insert the tub body 41 into the drawer body 31 to prevent the first support member 61 from interfering with the second support member 63, and thereafter may need to rotate the tub body 41 so that the second support member 63 and the first support member 61 are located on the vertical axis, in order to couple the first connection piece 651 to the first support member 61.
- [76] Although the feature by which the bar 655 of the tub support unit 6 is provided to form a right angle with respect to the bottom surface of the drawer 3 serves to minimize the distance between the outer circumferential surface of the tub body 41 and the inner circumferential surface of the drawer body 31 to minimize the volume of the laundry treatment apparatus 100, the strength of assembly of the first connection piece 651 and the first support member 61 may be deteriorated while the process described above is performed. This problem may be solved by making the first support member 61 separable from the drawer body 31.
- [77] The drum 5, which is provided inside the tub 4, may include a cylindrical drum body 51 having an opening 53 formed in the upper surface of the drum body 51. Because the opening 53 is located below the introduction aperture 431, the laundry supplied through the introduction aperture 431 may be supplied to the drum body 51 through the opening 53.
- [78] A plurality of drum through-holes 59 may be provided in the bottom surface 57 and the circumferential surface 55 of the drum body 51 for communication of the inside of the drum body 51 and the tub body 41.
- [79] The drum body 51 may be rotated inside the tub body 41 by a drive unit. The drive unit may include a stator M1 located outside the tub body 41 and may be fixed to the

bottom surface of the tub body 41, a rotor M2 configured to be rotated by a rotating magnetic field provided by the stator M1, and a rotating shaft M3 penetrating the bottom surface of the tub body 41 for connecting the bottom surface 57 of the drum 5 and the rotor M2 to each other. In this case, the rotating shaft M3 may be provided so as to form a right angle with respect to the bottom surface of the tub body 41.

- [80] The laundry treatment apparatus 100 may supply water to the tub 4 via a water supply unit 7, and may discharge water stored in the tub 4 to the outside of the cabinet 2 via a drain unit 8.
- [81] As illustrated in FIG. 2, the water supply unit 7 may include a first water supply pipe 71 connected to the supply aperture 433 formed in the tub cover 43, a second water supply pipe 73 connected to a water supply source, which is located at the outside of the cabinet 2, and a connection pipe 75 fixed to the tub cover 43 for connecting the first water supply pipe 71 and the second water supply pipe 73 to each other.
- [82] The first water supply pipe 71 may connect the supply aperture 433 and the connection pipe 75 to each other through the second through-hole 353 provided in the drawer cover 35. The first water supply pipe 71 may be a corrugated pipe in order to prevent the first water supply pipe 71 from being separated from the connection pipe 75 when the tub 4 vibrates (see FIG. 3).
- [83] In addition, the second water supply pipe 73 may also be a corrugated pipe in order to prevent the second water supply pipe 73 from being separated from the connection pipe 75 when the drawer 3 is discharged from the cabinet 2. The second water supply pipe 73 may be opened and closed by a water supply valve 77, which is controlled by a controller.
- [84] In some examples, the water supply unit 7 may include a single water supply pipe for connecting a water supply source, which is located at the outside of the cabinet 2, to the supply aperture 433 provided in the tub cover 43. In this case, the water supply pipe may be a corrugated pipe.
- [85] The drain unit 8 may include a drain pump 81 fixed to the drawer body 31, a first drain pipe 83 for guiding the water inside the tub body 41 to the drain pump 81, and a second drain pipe 85 for guiding the water discharged from the drain pump 81 to the outside of the cabinet 2. In this case, the second drain pipe 85 may be a corrugated pipe.
- [86] In the laundry treatment apparatus 100 having the configuration described above, after laundry is introduced into the drum 5 and water and detergent are supplied to the tub 4, the drum 5 is rotated via the drive unit so as to wash the laundry.
- [87] The laundry treatment apparatus 100 may further include at least one of a washing unit 91 for removing impurities (bubbles, contaminants or the like) that may remain on the door 45, and may include an ejection unit 93 for restraining the generation of

bubbles and washing the drum 5.

- [88] The washing unit 91 illustrated in FIG. 4 serves to wash the door 45 using the centrifugal force generated while the drum 5 is rotated.
- [89] The rotating shaft M3, which forms the center of rotation, forms a right angle with respect to the bottom surface of the tub body 41, the water inside the tub 4 is moved upward along the circumferential surface of the tub body 41 by centrifugal force while the drum 5 is rotated, and the water is then moved to the introduction aperture 431 along the tub cover 43. The washing unit 91 may discharge the water, moved to the tub cover 43 by centrifugal force, in the direction in which the door 45 is located, thereby washing the door 45.
- [90] The washing unit 91 of FIG. 4 may include a barrier 911 protruding from the tub cover 43 toward the upper surface of the drum 5, a guide 915 extending from the edge of the tub cover 43 toward the barrier 911, and a discharge hole 913 formed through the barrier 911 for the discharge of water moved along the guide 915 in the direction in which the door 45 is located.
- [91] The barrier 911 may be provided to surround the entire introduction aperture 431, as illustrated in FIG. 4(b). In some examples, a plurality of barriers may be spaced apart from one another along the edge of the introduction aperture.
- [92] As illustrated in FIG. 4(b) the barrier 911 may protrude from the edge of the introduction aperture 431 toward the drum 5.
- [93] When the door 45 is rotatably coupled to the upper surface of the tub cover 43 so that the inner surface of the door 45 (i.e. the surface of the door 45 that is in contact with water) is located higher than the discharge hole 913, the discharge hole 913 may be inclined at a prescribed angle to allow water to be discharged toward the door 45.
- [94] In addition, when the door 45 includes the window 455 formed of a transparent material, the discharge hole 913 may be inclined to allow water to be discharged to the window 455.
- [95] The guide 915 may include a first guide 915a and a second guide 915b. The first guide 915a guides water, moved to the edge of the tub cover 43, to the discharge hole 913 when the drum 5 is rotated in the clockwise direction. The second guide 915b guides water, moved to the edge of the tub cover 43, to the discharge hole 913 when the drum 5 is rotated in the counterclockwise direction.
- [96] In the case where the discharge hole 913 is a single hole formed in the barrier 911, the respective guides 915a and 915b may guide water to the same discharge hole 913. However, in the case where the discharge hole 913 includes a first discharge hole 913a and a second discharge hole 913b formed in the barrier 911, the first guide 915a may guide water to the first discharge hole 913a, and the second guide 915b may guide water to the second discharge hole 913b.

- [97] The washing unit 91 may wash the door 45 regardless of the direction in which the drum 5 is rotated so long as the number of revolutions per minute of the drum 5 is a preset reference number of revolutions per minute (i.e. the number of revolutions per minute by which the water inside the tub body 41 is moved upward to the tub cover 43).
- [98] In addition, the respective discharge holes 913a and 913b may be inclined at a prescribed angle so that the path of water discharged from the first discharge hole 913a and the path of water discharged from the second discharge hole 913b cross each other. This may serve to increase the washing range of the washing unit 91.
- [99] The washing unit 91 may be provided in a plural number along the edge of the introduction aperture 431, and the washing units 91 may be arranged to surround the introduction aperture 431. In addition, at least two of the washing units 91 may be arranged to face each other. This may serve to increase the washing capability of the washing unit 91.
- [100] The impurities remaining on the door 45 may be removed by a washing guide 456 illustrated in FIG. 5. The washing guide 456 may be provided at the edge of the window 455. During the rotation of the drum, water in the tub may move from the bottom surface of the tub to the edge of the frame 451 due to centrifugal force generated while the drum is rotated. The water may move around the edge of the frame 451. In the case in which the washing guide 456 is provided at the edge of the window, some of the water moved around the edge of the frame 451 may be guided toward the middle of the window 455 (W1 and W2). Consequently, it is possible to prevent the impurities from remaining on the window by the provision of the washing guide 456.
- [101] In order to maximize the washing area, the washing guide 456 may include a first washing guide 456a and a second washing guide 456b disposed so as to be center of the door 45, as illustrated in FIG. 5(b).
- [102] In some examples, one of the washing unit 91 and the washing guide 456 may be provided, and in some other examples, both the washing unit 91 and the washing guide 456 may be provided.
- [103] FIG. 6 illustrates one example of an ejection unit 93 for ejecting water introduced into the supply aperture 433 to the drum 5 to wash the inner circumferential surface of the drum 4 or to remove bubbles generated in the drum 5.
- [104] The ejection unit 93 may eject water in at least two different directions. As illustrated in FIG. 6, the ejection unit 93 may include an extension 933 protruding from the tub cover 43 to surround the supply aperture 433, a body 931 fixed to the extension 933 spaced apart from the supply aperture 433 by a predetermined distance, and at least two ejection holes formed through the extension 933 for discharging water introduced into the extension 933.

- [105] The ejection holes may include a first ejection hole 935, a second ejection hole 937, and a third ejection hole 939, by way of example. The respective ejection holes 935, 937, and 939 may be arranged at different intervals.
- [106] At least one of the ejection holes 935, 937, and 939 may be configured to eject water toward the circumferential surface 55 of the drum 5 in order to wash the circumferential surface of the drum 5, and at least one of the ejection holes 935, 937, and 939 may be configured to eject water toward the bottom surface of the drum 5 in order to remove bubbles generated in the drum 5.
- [107] In order to increase the pressure of water discharged from the respective ejection holes 935, 937, and 939, the body 931 may have an inclined surface, which is inclined upward toward the ejection holes 935, 937, and 939.
- [108] The inclined surface may include a first inclined surface 931a, which is inclined upward from the surface of the body 931 toward the first ejection hole 935, a second inclined surface 931b, which is inclined upward from the surface of the body 931 toward the second ejection hole 937, and a third inclined surface, which is inclined upward from the surface of the body 931 toward the third ejection hole 939.
- [109] Due to the inclined surfaces 931a and 931b, the sectional area of a flow channel, through which water moves, is gradually decreased from the center of the body 931 to the respective ejection holes 935, 937, and 939. The ejection unit 93 may increase the pressure of water discharged from the respective ejection holes 935, 937, and 939 to eject water to a distant place.
- [110] In some examples, the ejection unit 93 may be spaced apart from the center of rotation of the drum 5 by a predetermined distance. When the ejection unit 93 is located on the center of rotation of the drum 5, the ejection unit 93 may eject water to the edge of the drum 5, but it is difficult for the ejection unit 93 to eject water to center of rotation of the drum 5, which is located under the ejection unit 93.
- [111] A through hole may be formed in the body 931 to supply water to the center of rotation of the drum 5. The pressure of water discharged through the respective ejection holes 935, 937, and 939 may be reduced when the through hole is formed in the body 931.
- [112] In some examples, the ejection unit 93 may not be located on the center of rotation of the drum 5. In these examples, it is possible to supply water to the entire region of the drum 5 without a reduction in the pressure of the water ejected from the ejection unit 93.

CLAIMS:

1. A laundry treatment apparatus comprising:
 - a tub body configured to store water;
 - a tub cover configured to define an upper surface of the tub body;
 - an introduction aperture defined through the tub cover;
 - a supply aperture provided in the tub cover, and configured to enable supply of water into the tub body;
 - a drum that is rotatably provided in the tub body, and that is configured to receive laundry, the drum including an opening in communication with the introduction aperture;
 - a door configured to open and close the introduction aperture;
 - an ejection unit that ejects water introduced into the supply aperture to the drum in at least two different directions;
 - a rotating shaft configured to rotate the drum; and
 - a washing unit that ejects at least some water moved toward the tub cover to the door using centrifugal force generated while the drum is rotated.

2. The laundry treatment apparatus according to claim 1, wherein the ejection unit comprises:
 - an extension configured to surround the supply aperture;
 - a body that is fixed to the extension, and that is spaced apart from the supply aperture by a predetermined distance; and
 - at least two ejection holes defined through the extension and configured to discharge water introduced into the extension.

3. The laundry treatment apparatus according to claim 2, wherein the ejection unit further comprises at least two inclined surfaces configured to extend upward from a surface of the body toward each of the at least two ejection holes.
4. The laundry treatment apparatus according to claim 1, wherein the ejection unit is spaced apart from a center of rotation of the drum by a predetermined distance.
5. The laundry treatment apparatus according to claim 1, wherein the washing unit comprises:
 - a guide configured to extend from an edge of the tub cover toward the introduction aperture; and
 - a discharge hole configured to discharge water supplied through the guide in a direction in which the door is located.
6. The laundry treatment apparatus according to claim 5, wherein
 - the washing unit further comprises a barrier that protrudes from the tub cover toward an upper surface of the drum, the barrier being configured to surround an edge of the introduction aperture, and
 - the discharge hole is defined through the barrier.
7. The laundry treatment apparatus according to claim 6, wherein
 - the door is located above the introduction aperture, and
 - the discharge hole is inclined so as to discharge water toward the door.
8. The laundry treatment apparatus according to claim 6, wherein

the door comprises a frame rotatably coupled to the tub cover and a window provided in the frame such that an inside of the tub body is visible from an outside of the tub body, and

the discharge hole is inclined, and is configured to discharge water toward the window.

9. The laundry treatment apparatus according to claim 8, wherein the guide and the discharge hole comprise at least one guide and at least one discharge hole provided at an edge of the window.

10. The laundry treatment apparatus according to claim 1, further comprising:
a cabinet; and
a drawer configured to support the tub body.

11. The laundry treatment apparatus according to claim 1, wherein the rotating shaft is orthogonal to a bottom surface of the tub body, and
wherein the door comprises:
a frame rotatably coupled to the tub cover;
a window provided in the frame such that an inside of the tub body is visible from an outside of the tub body; and
a washing guide configured to guide at least some water moved to an edge of the frame to the window using centrifugal force generated while the drum is rotated.

12. The laundry treatment apparatus according to claim 3, wherein the at least two ejection holes comprise a first ejection hole defined through the extension, a second ejection

hole spaced apart from the first ejection hole by a predetermined angle, and a third ejection hole spaced apart from the second ejection hole by a predetermined angle.

13. The laundry treatment apparatus according to claim 12, wherein the inclined surface comprises a first inclined surface inclined upward from the body toward the first ejection hole, a second inclined surface inclined upward from the body toward the second ejection hole, and a third inclined surface inclined upward from the body toward the third ejection hole.

14. The laundry treatment apparatus according to claim 13, wherein the ejection unit is spaced apart from a center of rotation of the drum by a predetermined distance.

15. The laundry treatment apparatus according to claim 2, wherein at least one of the at least two ejection holes is configured to eject water toward a circumferential surface of the drum.

16. The laundry treatment apparatus according to claim 2, wherein at least one of the at least two ejection holes is configured to eject water toward a bottom surface of the drum.

17. The laundry treatment apparatus according to claim 1, wherein the ejection unit is located at a center of rotation of the drum.

[Fig. 1]

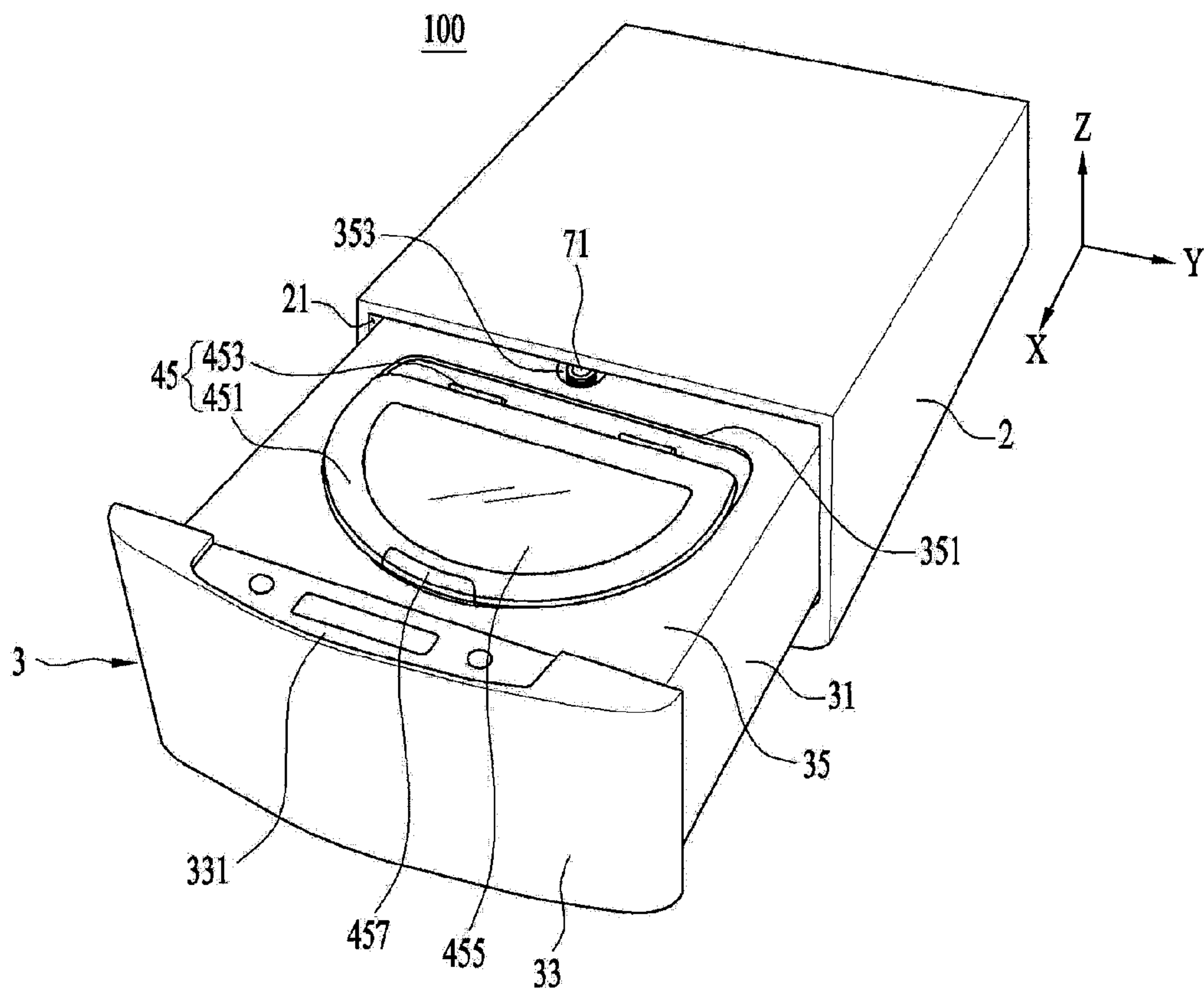

[Fig. 2]

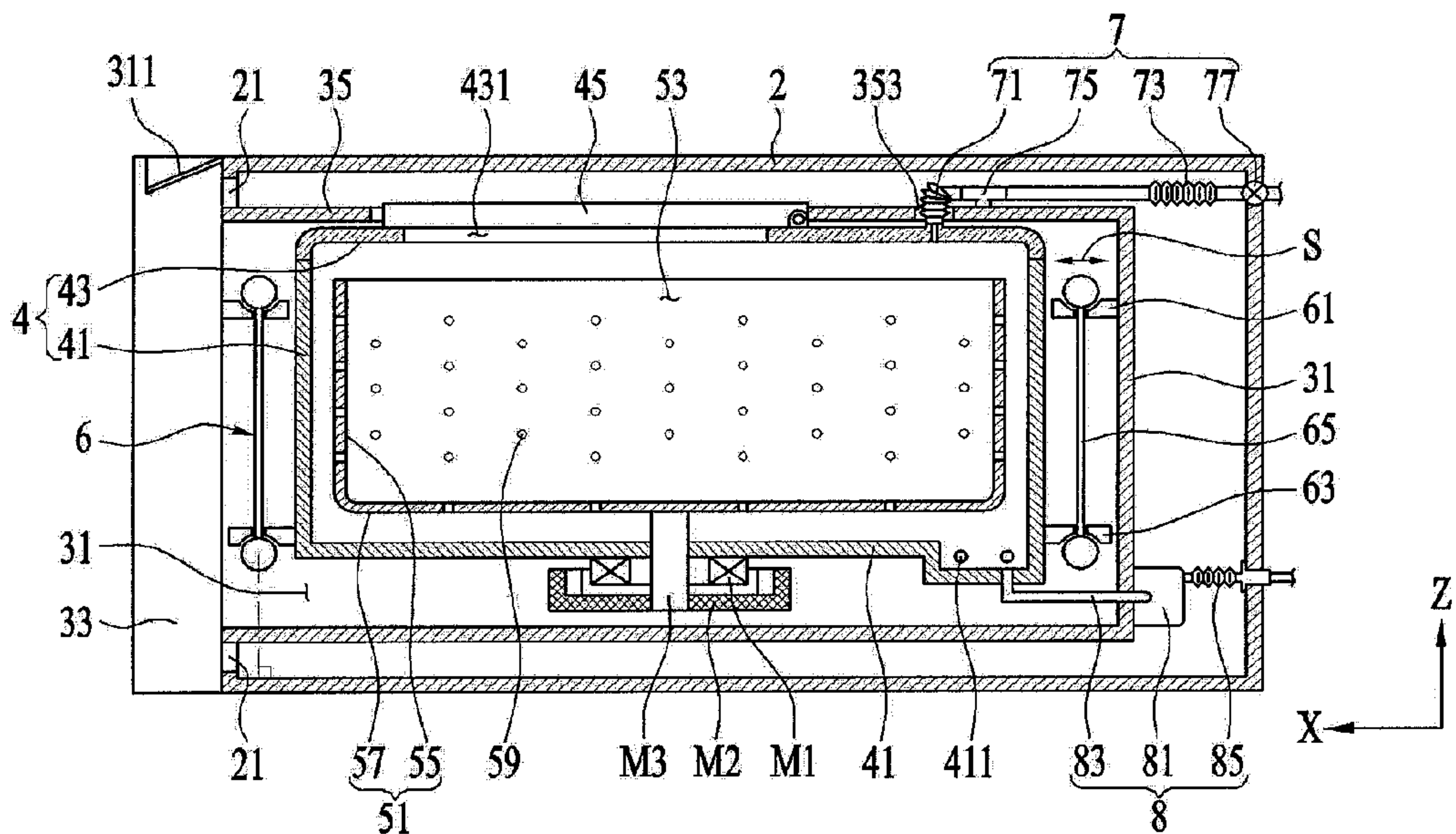

[Fig. 3]

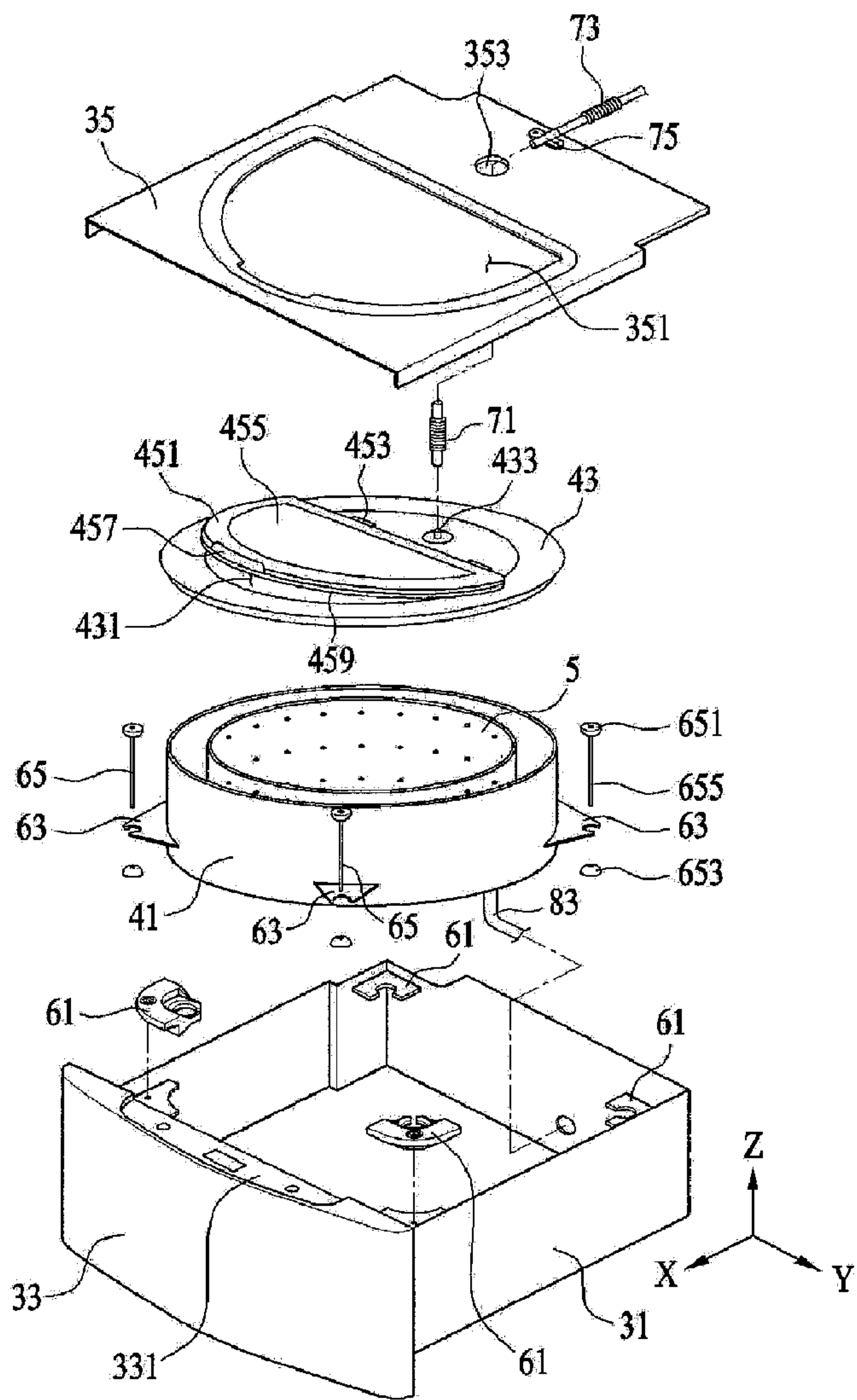

[Fig. 4]

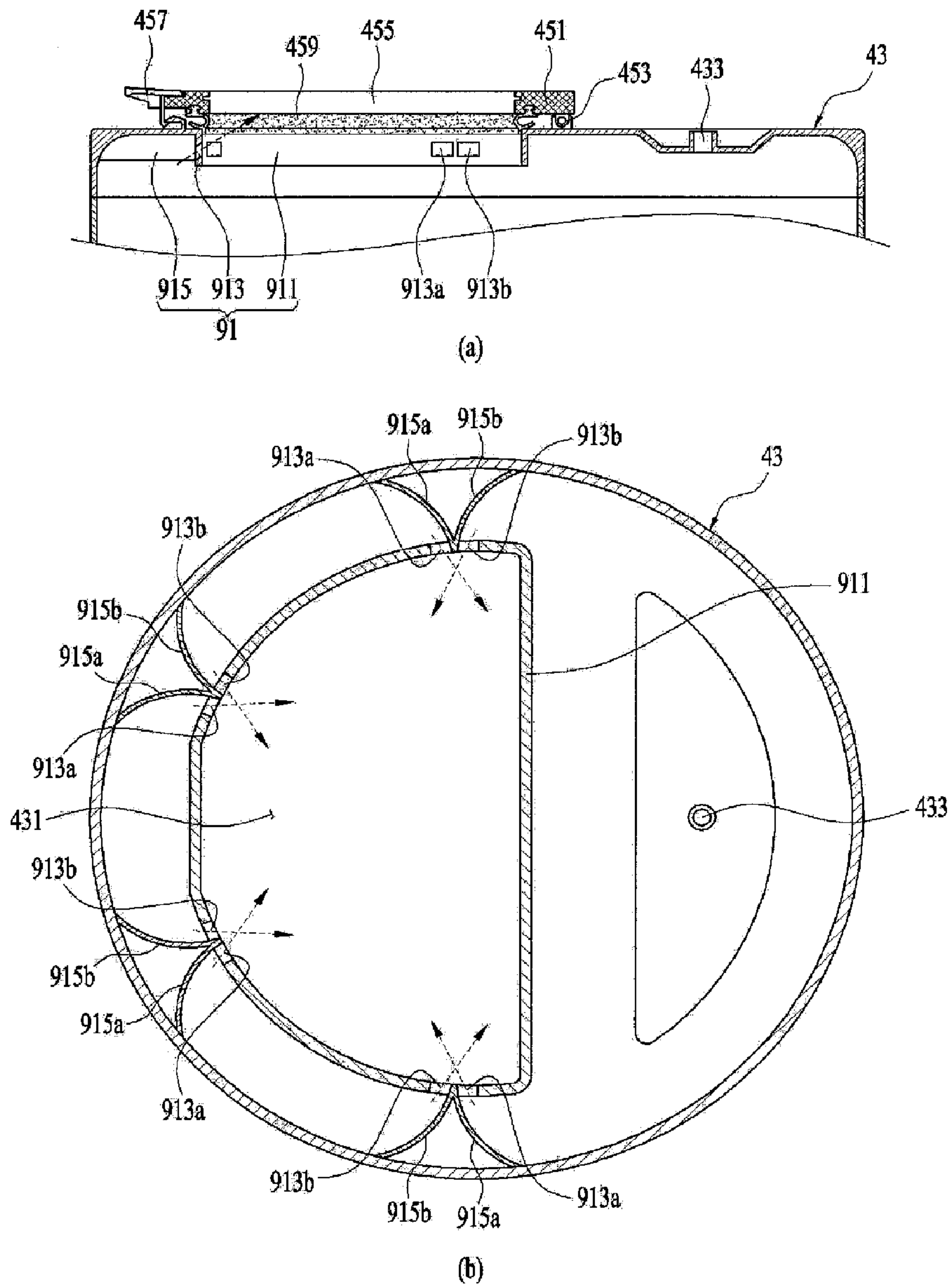

[Fig. 5]

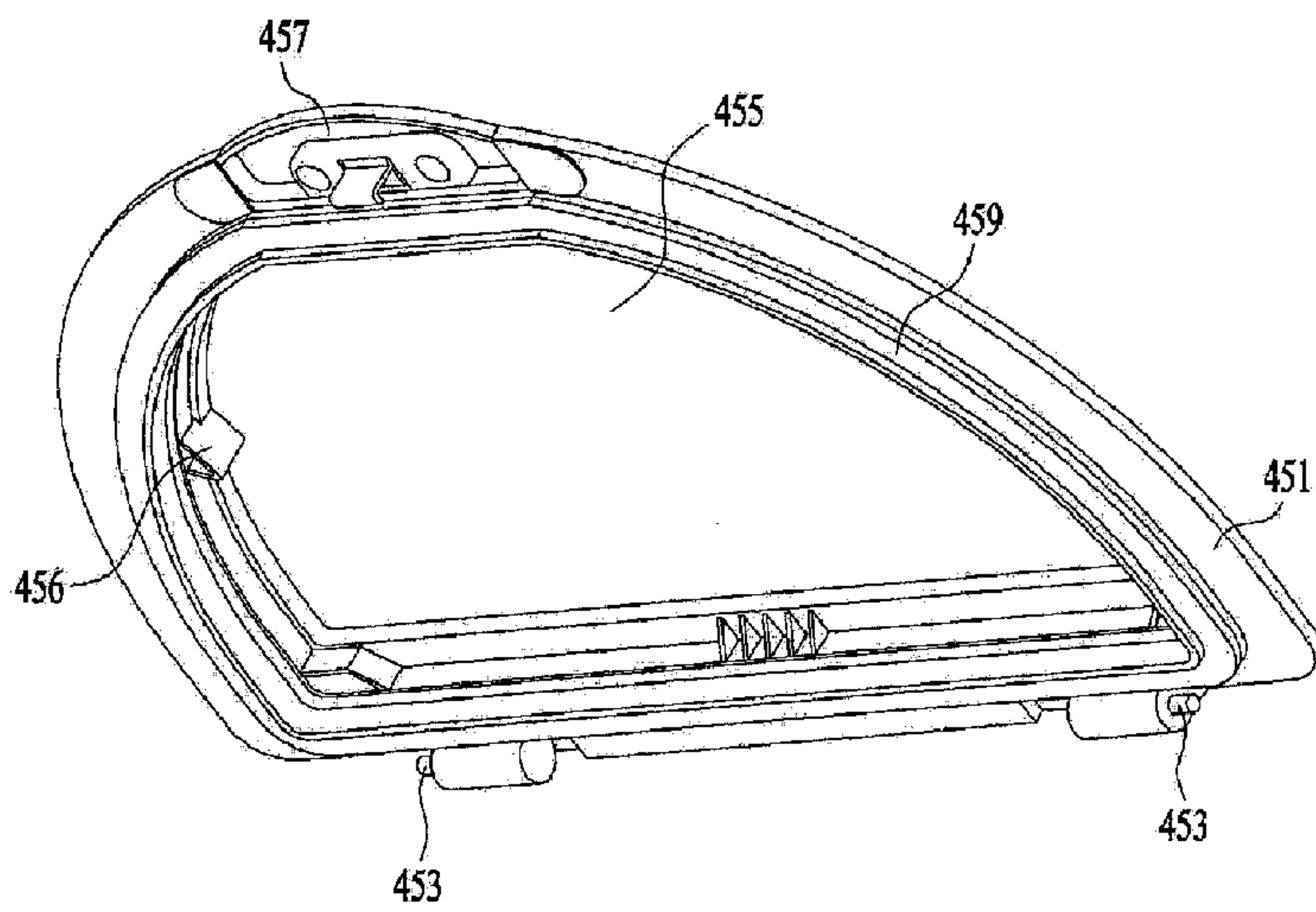

(a)

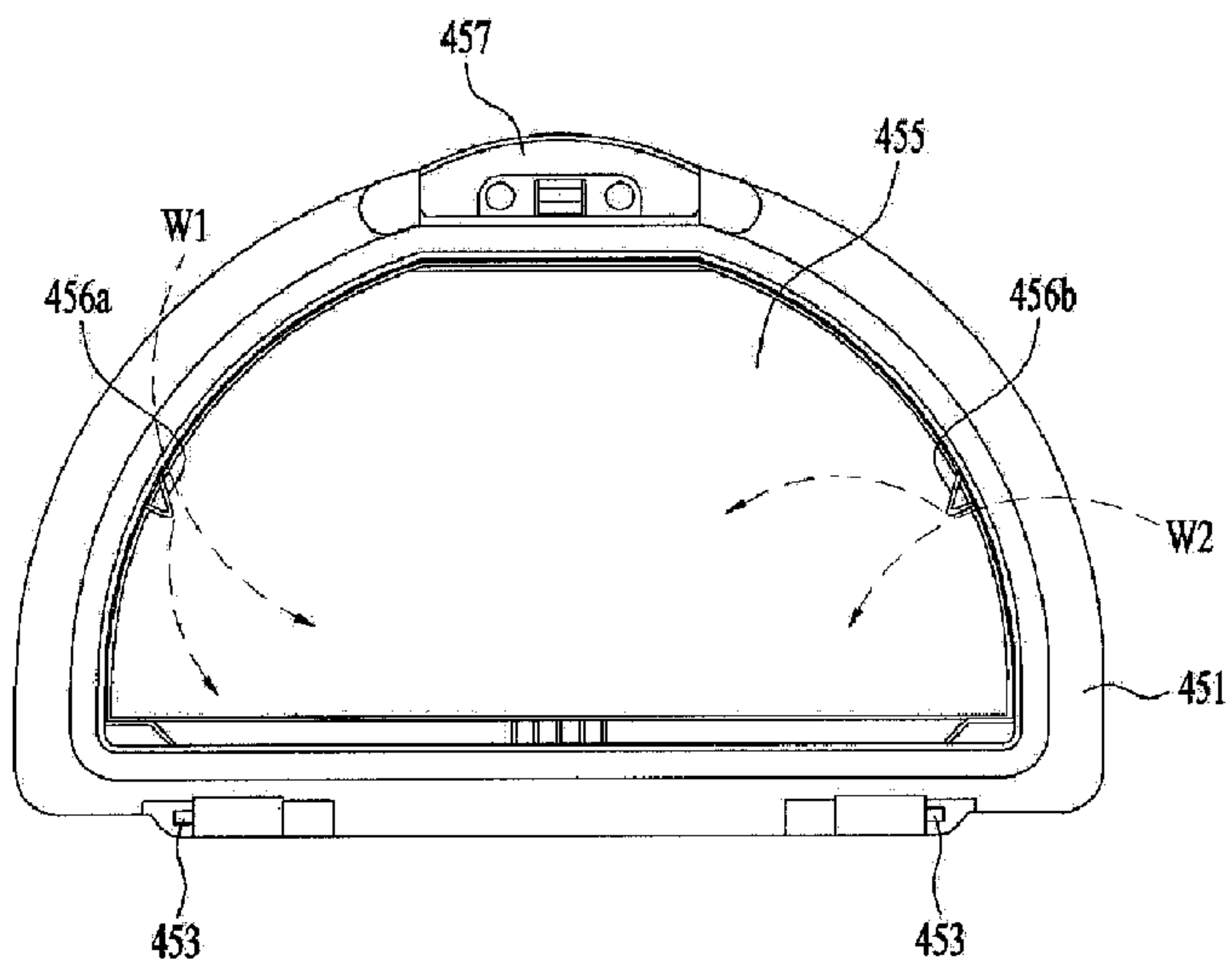

(b)

[Fig. 6]

