

**AUSTRALIA**  
Patents Act 1990

**NOTICE OF ENTITLEMENT**  
(To be filed before acceptance)

We RESEARCH LABORATORIES OF AUSTRALIA PTY LTD  
of 210 Greenhill Road, Eastwood, State of South Australia, Australia being the Applicant in  
respect of the Application <sup>No. 31526/93</sup> filed herewith, state the following:-

The person nominated for the grant of the patent:

has entitlement from the actual inventor by reason of Deed of Assignment dated 17th  
December 1992

The person nominated for the grant of the patent:

is the applicant of the application listed in the declaration under Article 8 of the PCT

The basic application referred in the declaration under Article 8 of the PCT is the first application  
made in a Convention country in respect of the invention.

The COMMON SEAL of  
RESEARCH LABORATORIES )  
OF AUSTRALIA PTY LTD )  
was hereunto affixed this <sup>10d</sup> )  
day of June 1994 )  
in the presence of: )

J. M. Alston  
Director

Chama  
Secretary





AU9331526

**(12) PATENT ABRIDGMENT (11) Document No. AU-B-31526/93**  
**(19) AUSTRALIAN PATENT OFFICE (10) Acceptance No. 664404**

- (54) Title  
**METHOD AND APPARATUS FOR THE PRODUCTION OF DISCRETE AGGLOMERATIONS OF PARTICULATE MATTER**
- International Patent Classification(s)  
(51)<sup>5</sup> **B01J 002/06 B03C 005/02 B41J 002/06 B41J 027/18**
- (21) Application No. : **31526/93** (22) Application Date : **17.12.92**
- (87) PCT Publication Number : **WO93/11866**
- (30) Priority Data
- (31) Number (32) Date (33) Country  
**PL0069 18.12.91 AU AUSTRALIA**
- (43) Publication Date : **19.07.93**
- (44) Publication Date of Accepted Application : **16.11.95**
- (71) Applicant(s)  
**TONEJET CORPORATION PTY LTD**
- (72) Inventor(s)  
**LUIS LIMA-MARQUES**
- (74) Attorney or Agent  
**COLLISON & CO , 117 King William Street, ADELAIDE SA 5000**
- (56) Prior Art Documents  
**US 3575841**
- (57) Claim

1. A method of generation of discrete agglomerations of a particulate material with a proportion of liquid from a liquid having the particulate material therein, the method comprising the steps of providing the liquid including the particulate material to an ejection location, applying an electrical potential to the ejection location to form an electric field at the location and causing agglomerations to form at the ejection location and ejecting into air such agglomerations away from the ejection location by electrostatic means.

OPI DATE 19/07/93 APPLN. ID 31526/93  
AOJP DATE 16/09/93 PCT NUMBER PCT/AU92/00665



AU9331526

(CT)

<p>(51) International Patent Classification <sup>5</sup> : B01J 2/06, B03C 5/02 B41J 2/06, 27/18</p>	<p>A1</p>	<p>(11) International Publication Number: WO 93/11866 (43) International Publication Date: 24 June 1993 (24.06.93)</p>
<p>(21) International Application Number: PCT/AU92/00665 (22) International Filing Date: 17 December 1992 (17.12.92) (36) Priority data: PL 0069 18 December 1991 (18.12.91) AU Tonejet Corporation Pty Ltd (71) Applicant (for all designated States except US): RESEARCH LABORATORIES OF AUSTRALIA PTY. LTD. [AU/AU]; 210 Greenhill Road, Eastwood, S.A. 5063 (AU). (72) Inventor; and (75) Inventor/Applicant (for US only) : LIMA-MARQUES, Luis [AU/AU]; 24 Brookside Road, Darlington, S.A. 5047 (AU). (74) Agent: COLLISON &amp; CO.; 117 King William Street, Adelaide, S.A. 5000 (AU).</p>		<p>(81) Designated States: AT, AU, BB, BG, BR, CA, CH, CS, DE, DK, ES, FI, GB, HU, JP, KP, KR, LK, LU, MG, MN, MW, NL, NO, NZ, PL, RO, RU, SD, SE, UA, US, European patent (AT, BE, CH, DE, DK, ES, FR, GB, GR, IE, IT, LU, MC, NL, PT, SE), OAPI patent (BF, BJ, CF, CG, CI, CM, GA, GN, ML, MR, SN, TD, TG).</p> <p>Published With international search report.</p>  <p>664404</p>

(54) Title: METHOD AND APPARATUS FOR THE PRODUCTION OF DISCRETE AGGLOMERATIONS OF PARTICULATE MATTER

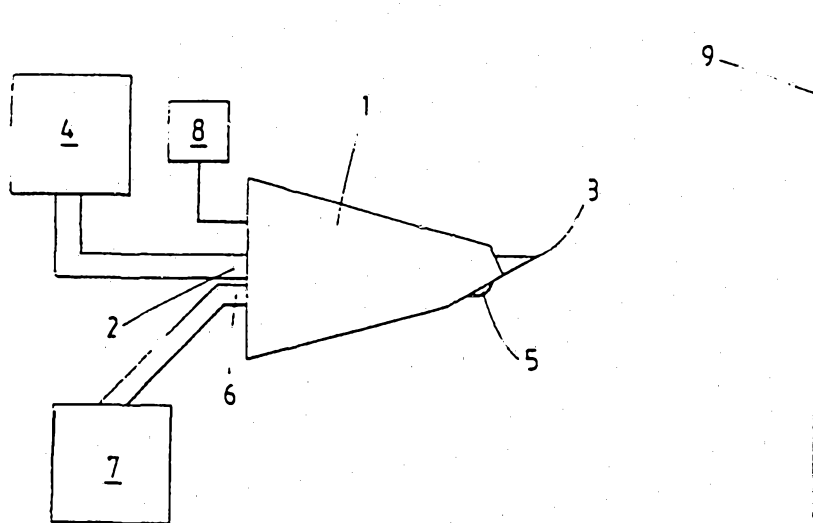

(57) Abstract

A method and apparatus is provided for the generation of agglomerations of particulate material in a liquid. Agglomerations are built up at a point under the effect of an electric field and ejected by electrostatic means. The size of the agglomeration is dependent upon the strength of the electric field, point geometry, the nature of the liquid and the nature of the particles. Agglomerations of particles in the range of from 1 to 500 microns are produced. The invention is useful for non-impact printing and other applications where delivery of agglomerations of particles is useful such as in inhalable pharmaceuticals.

## METHOD AND APPARATUS FOR THE PRODUCTION OF DISCRETE AGGLOMERATIONS OF PARTICULATE MATTER

### BACKGROUND OF THE INVENTION

This invention relates to a method and apparatus for the transfer of  
5 agglomerations of solid particulate matter suspended in a liquid to a recording surface.

One particular application to which this invention may be applied is the transfer of agglomerations of high intensity colouring materials to a recording surface for the purpose of non-impact printing. It is to be understood,  
10 however, that the invention is not limited to delivering coloured materials for the purpose of non-impact printing but may be used to deposit other materials in a defined pattern on a substrate. Examples of other applications include the delivery of biological materials for use in immunoassay, delivery of particulate drugs and deposition of phosphors or fluorphosphors for security  
15 coding.

This invention, however, will be discussed in relation to its application to printing but its scope is broader than this.

There are a number of different forms of equipment used for the non-impact printingsystems which are generally referred to as ink jet printing. It is usual  
20 for ink to be fed through a nozzle, the exit diameter of which nozzle being a major factor in determining the droplet size and hence the size of the resulting dots on a recording surface. The droplets may be produced from the nozzle either continuously in which case the method is termed continuous printing or they may be produced individually as required in which case the method is  
25 termed drop on demand printing. In continuous printing an ink is delivered through the nozzle at high pressure and the nozzle is perturbed at a substantially constant frequency which results in a stream of droplets of constant size. By applying charge to the droplets and using an electric field external to the nozzle selected droplets may be deflected in their passage to  
30 the recording surface in response to a signal effecting the electric field whereby forming a pattern on the recording surface in response to the control signal. Drop on demand printing operates by producing local pressure pulses

in the liquid in the vicinity of a small nozzle which results in a droplet of liquid being ejected from the nozzle.

In either type of jet printing the colouring material is a soluble dye combined with binders to render the printed image more permanent. The disadvantage  
5 of soluble dyes is that the printed image density is not high enough in many applications and that the dyes fade under exposure in the environment. A further disadvantage with soluble dye materials is that the quality of the printed image is dependent on the properties of the recording surface. Pigmented inks are known to produce higher density images than soluble  
10 dyes and are also more permanent. Pigments may also be used in jet printers but the production of a dense image requires a high concentration of pigment material in a liquid carrier. The high concentration of pigment material affects the droplet breakup in continuous printers and results in less uniform printing. Drop on demand printers do not have a high continuous pressure and the  
15 droplet generation is strongly dependent on local conditions in the nozzle, therefore the presence of pigments can block the nozzle or otherwise modify the local nozzle conditions or block the nozzle such that droplets are not correctly ejected.

A further process, known as electrostatic ink jet printing, is characterised by an  
20 electrostatic pull on a liquid and is disclosed in for instance US Patent 3,060,429. This involves the generation and acceleration of charged droplets, from a nozzle containing the liquid, to a platen electrode by a high voltage being maintained between the nozzle and the platen. This process is further optimised by including a valving electrode that is used to interrupt or control  
25 the jet flow as well as two pairs of electrodes used to manipulate the flight path of the droplets. Ink jet printing is achieved by locating a paper substrate just prior to the platen electrode and using a conductive solution of ink.

It is an object of this invention to provide agglomerations of particulate  
30 material in a liquid which are not produced by a nozzle and hence the size of the agglomerations are not affected by the size of the nozzle.

It is a further object of this invention to provide agglomerations of particles in a liquid with a very high concentration of particulate material so that a high concentration of the particulate material can be provided onto a recording surface.

It is a further object of this invention to produce agglomerations of particles in a liquid using a liquid which is not necessarily conductive.

#### DESCRIPTION OF THE INVENTION

In one form the invention is said to reside in a method of generation of discrete  
5 agglomerations, clumps, aggregates, accumulations, clusters or the like of a  
particulate material in a liquid from a liquid having the particulate material  
therein, the method comprising the steps of providing the liquid including the  
particulate material to an ejection location, applying an electrical potential to  
the ejection location to form an electric field at the location and causing  
10 agglomerations to form on the ejection location and ejecting such  
agglomerations away from the ejection location by electrostatic means.

In a further form the invention is said to reside in a method of generation of  
discrete agglomerations, clumps, aggregates, accumulations, clusters or the  
like of a particulate material in a liquid from a liquid having a lesser  
15 concentration of a particulate material therein, the method comprising the  
steps of providing the liquid including the particulate material in the lesser  
concentration to an ejection location, applying an electrical potential to the  
ejection location to form an electric field at the location and causing  
agglomerations of particles within the liquid to form on the ejection location  
20 with a higher concentration of the particulate material within the liquid and  
ejecting such agglomerations away from the ejection location by electrostatic  
means.

It will be seen that by this invention the size of the agglomerations are not  
dependent upon the size of any nozzle which delivers liquid carrying the  
25 particulate material to the ejection location but is dependent upon the ejection  
location geometry, the level of the electrical field and the nature of the liquid  
and particulate material.

It can also be seen that the present invention differs from the prior art in that  
the liquid is not necessarily a conductive liquid. Agglomerations of particles in  
30 the liquid appear to be formed by electrostatic means acting upon the  
particles. The liquid acts solely as a carrier. The transfer of particles instead  
of liquid solutions of colouring matter means that a more intense image can be  
formed on a substrate and a finer dot size can be formed with a quicker drying

dot.

In one preferred form of the invention the electrical potential forming the field may be pulsed so that there is periodic formation and ejection of agglomerations of particles in the liquid from the ejection location.

- 5 There may, therefore, be provided a flow of liquid including a particulate material to the ejection location and the withdrawal of excess liquid from the ejection location. Such withdrawal of excess liquid may be by means of a vacuum extraction. It will be realised that a certain amount of particulate material may be withdrawn along with the excess liquid from the ejection  
10 location.

- The electrical potential will cause a electric field to build at the ejection location particularly dependent upon the geometry such as the radius of curvature of the ejection location and in a preferred embodiment of the invention the ejection location may be provided by a needle having a radius of  
15 curvature at its tip in the range of 5-50 microns. Alternatively the ejection location may be provided by an elongate sharpened edge. There may be a number of ejection locations along the elongate edge or there may be a matrix of ejection locations.

- The method of this invention may produce agglomerations of particles in the  
20 liquid with a high concentration of particulate material therein in a size range of 1 microns to 500 microns in diameter.

- Preferably the liquid is a non-electrically conducting liquid and the particulate material is comprised of chargeable particles. Preferably the chargeable particles may be charged to the same polarity as the voltage applied to the  
25 ejection location.

The electrical potential applied to the ejection location may be in the range of 500 to 5000 volts.

- In an alternative form the invention may be said to reside in an apparatus for  
30 generation of discrete agglomerations, clumps, aggregates, accumulations, clusters or the like of a particulate material in a liquid from a liquid having the particulate material in a lesser concentration comprising an ejection location,

means to apply an electrical potential to the ejection location to form an electric field at the location and means to supply liquid with the particulate material of the lesser concentration to the ejection location.

5 It will be seen that by this form of the invention an apparatus is provided which will enable agglomerations of particles in a liquid and containing a high concentration of particulate material to be produced and ejected from the ejection location.

10 There may be further provided means to provide a flow of liquid to the ejection location. Such a flow may be provided by means of a pump or by gravity feed or some other means.

There may be further included vacuum extraction means to withdraw excess liquid and any carryover of particulate material from the ejection location.

15 In one form the ejection location may be provided by a needle point having a radius of curvature of from 5 to 50 microns or the ejection location may be provided by an elongate edge having a semi cylindrical surface having a radius of curvature of 5 to 50 microns. Alternatively the ejection location may comprise a matrix of ejection points.

20 The apparatus according to this invention may be adapted to provide agglomerations on demand or to provide a continuous stream of agglomerations which can be deflected by electrostatic means external to the apparatus. The supply of agglomerations of particulate material on demand may be provided by providing a pulsed electrical potential to the ejection location.

25 Generally it can be seen that this invention provides what may be termed an electrophoretic concentration of particulate material in a liquid at an ejection location and the electrostatic ejection of such agglomerations.

30 Although the mechanism for operation of the agglomeration formation is not fully understood one theory, to which the applicants are not necessarily bound, is as follows. Particles in the liquid flowing to the ejection location are inherently charged or charged to the same polarity as the ejection location and because of the electrical field concentration which would build up



particularly at the tip of the ejection location more and more particles build up on the ejection location expanding an agglomeration of particles within the entrained liquid and with increasing repulsion the particles moving away from the ejection location until electrostatic repulsion between the ejection location and the agglomeration of the charged particles builds up to such an extent that surface tension of the entrained liquid can no longer hold the agglomeration to the ejection location. At this stage the agglomeration is repulsed by electrostatic means.

It may be particularly noted that because the repulsion is substantially electrostatic no earthed substrate is necessary to attract the agglomerations to a substrate and in fact considerable distances of agglomeration flight can occur before they impinge a substrate. This enables suitable electrostatic or other forms of deflection equipment to provide whatever patterning of agglomerations is required on a substrate.

It should be noted that the invention is not limited to the supply of coloured ink particles for the purposes of printing onto substrates. In the field of medical technology there are many instances where it is desirable to deliver insoluble particulate material without the use of gas operated atomisers. Many inhalant pharmaceuticals are delivered as particulates, examples include beclomethasone dipropionate which is the most common corticosteroid used in the treatment of asthma and sodium cromoglycate used as a prophylactic for asthma. These may be applicable to the present invention because an agglomeration of particles of the pharmaceutical can be delivered with a minimum of carrier liquid.

The invention therefore generally covers the delivery of particulate pharmaceuticals for instance into the respiratory tract suspended in a non-toxic insulative carrier. Such a system provides a fast route for the delivery of drugs to the blood stream.

This then generally describes the invention but to assist in understanding the invention reference will now be made to the accompanying drawings which show a preferred embodiment of the invention and illustrates a theoretical action of the invention.

BRIEF DESCRIPTION OF DRAWINGS

In the drawings:

FIG. 1 shows a sectional view of an ejection location assembly of a first embodiment of the invention.

5 FIG. 2 shows the ejection location of Figure 1 and a printing substrate to be imaged

FIG. 3 shows an alternative embodiment of a drop generation apparatus according to the invention utilising an ejection edge rather than an ejection point

10 FIG. 4 shows an alternative embodiment of a drop generation apparatus according to the invention utilising multiple ejection points

FIG. 5 shows one interpretation of the method of operation of the invention

#### DESCRIPTION OF THE PREFERRED EMBODIMENT

15 FIG. 1. is a sectional side view of a preferred embodiment showing the apparatus for generation of discrete agglomerations of particles in a liquid including the supply of a liquid containing particulate material, the ejection location, means to apply a high voltage and a means to withdraw excess liquid and particulate material.

20 FIG. 1 illustrates the principal aspect of the invention, in which the apparatus for generation of discrete agglomerations of particles within a liquid consists of an electrically conducting body 1 fashioned to a tapered point. Within the body 1 and in electrical contact with it is an electrically conducting supply tube 2. The supply tube 2 is longer than the body 1 and protrudes from the body 1 at both ends. At the tapered end of the body 1, the supply tube 2 is finished at an angle of 30° to its length and therefore has a point with a small radius of  
25 curvature on the top surface, referred to as an ejection point 3. The other end of the supply tube 2 connects with a constant pressure supply system 4 for the particulate containing liquid. The constant pressure supply system can be a gravity feed to the supply tube 3 or it can be a pump drawing liquid containing  
30 the particulate material from a reservoir (not shown). Below the ejection point

3 on the underside of the body 1 is a flow director 5 in the form of a vane, which directs the excess liquid and particulate material to the removal channel 6. The removal channel 6 is connected to an external extraction system 7, which removes and reclaims the excess liquid and particulate material. The  
5 external extraction system can be a vacuum extraction system. A voltage 8 can be applied to the body 1 and therefore to the supply tube 2.

To operate the invention particulate containing liquid is supplied to the body 1 via the supply system 4 at a constant low pressure. The particulate containing liquid passes along the supply tube 2 towards the ejection point 3. When a  
10 voltage 8 is applied to the body 1 then, due to the shape of the body 1 and the supply tube 2, the electric field created is greatest at the ejection point. The particulate material in the liquid is inherently charged or charged to the same polarity as the applied voltage, is concentrated at the ejection point 3 and, if the field is sufficiently strong, then a agglomeration of particulate material  
15 together with a small amount of liquid is ejected in the direction normal to the ejection point. If the voltage is maintained then the ejection will be repeated with a frequency dependent on the magnitude of the applied voltage, geometry of the apparatus, properties of the liquid and properties of the particulate material. The residual liquid and any remaining particulate material  
20 are directed to the removal channel 6 by means of the flow director or vane 5 and withdrawn by the extraction system 7.

FIG 2 show the apparatus assembly of the embodiment of Fig 1 and a substrate 9 and illustrates the relative position of the agglomeration generating apparatus and the substrate. Agglomerations of particles in a  
25 liquid generated at the ejection point are propelled by electrostatic means to the substrate and impinge thereon. The substrate may be between 1 mm and 200 mm away from the ejection point depending upon the magnitude of the applied voltage, geometry of the ejection point and the properties of the liquid and the particulate material.

30 Figure 3 shows an alternative embodiment of the invention employing an ejection edge 13. The ejection edge 13 is a blade 12 protruding from the tip of a wedge shaped body 10. The body 10 and the blade 12 are in electrical contact. When a voltage 8 is applied to the body 10 then, due to the shape of the body 10 and the blade 12, the electric field is greatest at the ejection edge  
35 13. Particulate containing liquid, which is supplied to the body 10 via a supply

system 14, passes along a supply channel 11 towards the ejection edge 13. If the field is sufficiently strong agglomeration of particulate material together with a small amount of liquid will be ejected from the ejection edge 13. The positions along the ejection edge 13 at which ejection occurs are dependent on the geometry of the edge. If the voltage is maintained then the ejection of agglomerations is repeated with a frequency dependent on the magnitude of the applied voltage, geometry of the apparatus, properties of the liquid and the properties of the particulate material. The repeated ejection occurs along the ejection edge 13. The residual liquid and any remaining particulate material are removed in the same manner as described in FIG. 1.

If a small point is made on the ejection edge 13 then the ejection will usually only occur at this point. Likewise, if a second point is made then ejection will normally only occur at these two points.

FIG. 4 shows an extension of the design as described in FIG. 3 with a multiplexed system employed. The wedge shaped body 10 is made up of electrically conducting sections 16 separated by insulative material 15. Likewise, the blade 17 comprises electrically conducting sections 18 which are separated by insulative material 19. At the end of the blade 17 the conducting sections 18 protrude from the insulating material 15 and each is machined to an ejection point 20.

Supply of the particulate containing liquid to the ejection points 20 and removal of the residual liquid and any remaining particulate material are as described in FIG. 3 and FIG. 1 respectively. A voltage  $V$ ,  $V'$  or  $V''$  can be applied to any one conducting section 16 such that agglomeration of particulate material together with a small amount of liquid are ejected from the corresponding ejection point 20. By applying a voltage  $V$ ,  $V'$  or  $V''$  to other conducting sections 16 agglomerations of particulate material in a liquid can be made to eject from the corresponding ejection points 20. Subject to control electronics supplying the applied voltages  $V$ ,  $V'$  or  $V''$  it is possible to eject agglomerations of particulate material in a liquid from the ejection points 20 in any combination and for any desired time span.

Figures 5A to 5E show one possible explanation of the stages of formation of agglomerations at the ejection location where the agglomerations have a greater concentration of the particulate material than the liquid supplied to the

ejection location. The applicants are not intending to be limited to this explanation.

- Liquid 31 containing a particulate material is supplied to the ejection location 30 by flowing liquid and the particulate material along a surface of the body leading up to the ejection location 36 as shown in Figure 5A. As they reach the ejection location the particles are charged to the same polarity as the electrical potential at the ejection location and because of the high electrical field concentration that forms at the ejection location the particles are repulsed to commence the formation of an agglomeration 32 as can be seen in figure 5B.
- 10 As more and more particles are repulsed from the ejection location and join the forming agglomeration the size of the agglomeration 33, 34 forming at the ejection location is increased as shown in Figure 5C and D but is prevented from escaping due to surface tension in the liquid. When the agglomeration contains sufficient particles the electrostatic repulsion is sufficiently strong to
- 15 overcome the surface tension of the liquid and the agglomeration 35 escapes as shown in Figure 5E. Electrostatic repulsion between the ejection location and the escaping agglomeration causes the agglomeration to travel in a straight line dependant on the electrostatic field geometry about the ejection location.

## EXAMPLES

Tests were carried out using three combination of voltage, liquid, particulate material and point geometry. In each the apparatus was as shown in Figure 1 with a single ejection point. Results are as shown in the table below.

5 TABLE

	1	2	3
VOLTAGE	1000 Volts	2500 Volts	5000 Volts
PARTICULATE MATERIAL	ORGANIC PIGMENT	ORGANIC PIGMENT	CARBON BLACK
LIQUID	ISOPARAFFIN I.B.P 159°C	ISOPARAFFIN I.B.P 159°C	ISOPARAFFIN I.B.P 190°C
RADIUS OF CURVATURE OF EJECTION POINT	25 $\mu$ m	25 $\mu$ m	25 $\mu$ m
RADIUS OF FORMED AGGLOMERATION	4 $\mu$ m	10 $\mu$ m	10 $\mu$ m
THROW DISTANCE	90 mm	5 mm	50 mm
RADIUS OF PRINTED DOT	8 $\mu$ m	25 $\mu$ m	30 $\mu$ m

I.B.P. is Initial Boiling Point

It can be seen that the radius of the agglomeration and hence the radius of the printed dot can be altered by changing the variables.

1. A method of generation of discrete agglomerations of a particulate material with a proportion of liquid from a liquid having the particulate material therein, the method comprising the steps of providing the liquid including the particulate material to an ejection location, applying an electrical potential to the ejection location to form an electric field at the location and causing agglomerations to form at the ejection location and ejecting into air such agglomerations away from the ejection location by electrostatic means.
2. A method as in claim 1 further including the step of periodic formation and ejection of agglomerations from the ejection location.
3. A method as in claim 1 further including the step of providing a flow of the liquid including the particulate material to the ejection location.
4. A method as in claim 1 further including the step of withdrawal of excess liquid from the ejection location.
5. A method as in claim 4 wherein the withdrawal of the excess liquid from the ejection location is by means of vacuum extraction.
6. A method as in any one preceding claim wherein the ejection location is provided by a needle point having a radius of curvature at its tip in the range of 5 to 50 microns.
7. A method as in claim 1 wherein the ejection location comprises an elongate edge.
8. A method as in claim 7 wherein there is a plurality of ejection points along the elongate edge.
9. A method as in any one preceding claim wherein agglomerations in the range of 1 microns to 500 microns in diameter are produced.
10. A method as in any one preceding claim where the liquid is a non-electrically conducting liquid.



11. A method as in any one preceding claim where the particulate material is comprised of chargeable particles.
12. A method as in claim 11 wherein the chargeable particles are able to be charged to the same polarity as the voltage applied to the ejection location.
- 5 13. A method as in claim 11 wherein the chargeable particles are inherently charged to the same polarity as the voltage applied to the ejection location.
14. A method as in any one of claims 1 to 13 wherein the electrical potential is in the range of 500 to 5000 volts.
- 10 15. A method as in any one of claims 1 to 14 wherein the agglomeration size and proportion of liquid is dependant upon variation of one or more of the nature of the liquid, the particulate material and the electrical potential.
16. An apparatus for generation and ejection into air of discrete agglomerations of a particulate material with a proportion of liquid from a liquid having the particulate material therein comprising an ejection location, means to apply an electrical potential to the ejection location to form an electric field at the location and means to supply liquid with the particulate material to the ejection location.
- 15
17. An apparatus as in claim 16 further including means to provide a flow of liquid to the ejection location.
- 20
18. An apparatus as in claim 16 further including vacuum extraction means to withdraw excess liquid and particulate material from the ejection location.
19. An apparatus as in claim 16 where the ejection location is provided by needle point.
- 25 20. An apparatus as in claim 16 where the ejection location is provided by an elongate edge.





21. An apparatus as in claim 16 where the ejection location comprises a plurality of points along an elongate edge.
22. An apparatus as in claim 16 wherein the ejection location comprises a matrix of ejection points.
- 5 23. An apparatus as in any one of claims 16 to 22 wherein the ejection location provides a hemispherical or semi-cylindrical surface having a radius of curvature in the range of 5 to 50 microns.
24. An apparatus as in claim 16 adapted to provide periodic formation and ejection into air of agglomerations of particles in the liquid.
- 10 25. An apparatus as in claim 16 wherein the electrical potential is in the range of 500 to 5000 volts.



1/3

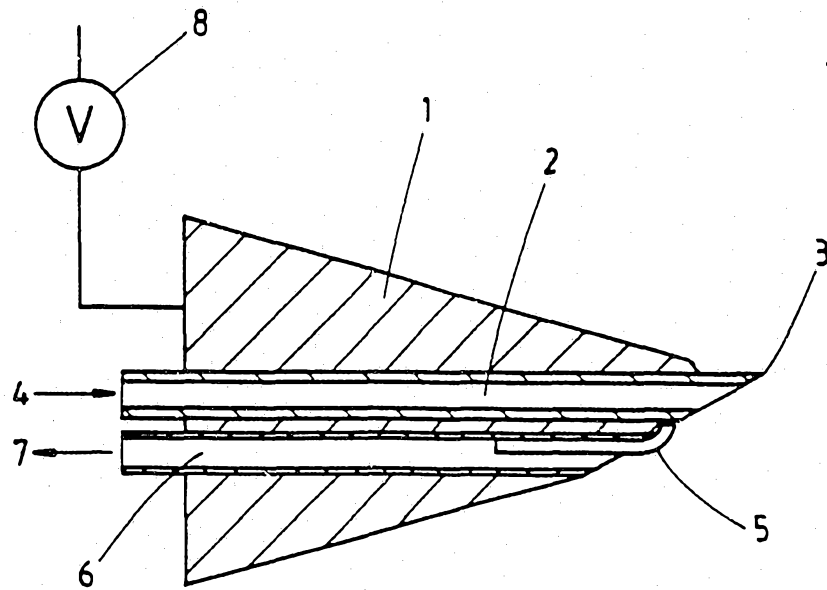

**FIG 1**

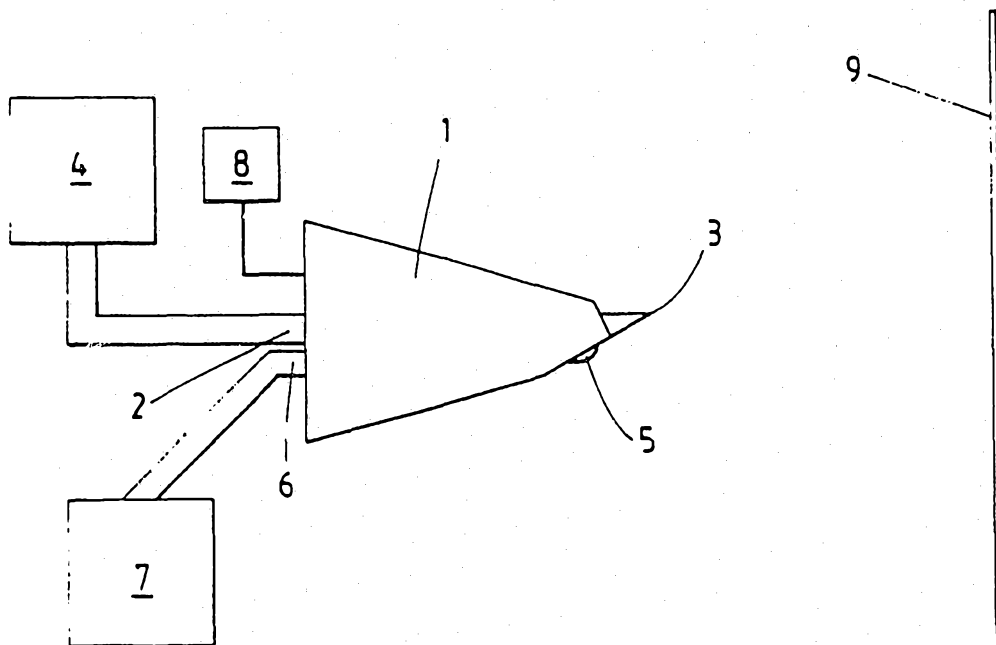

**FIG 2**

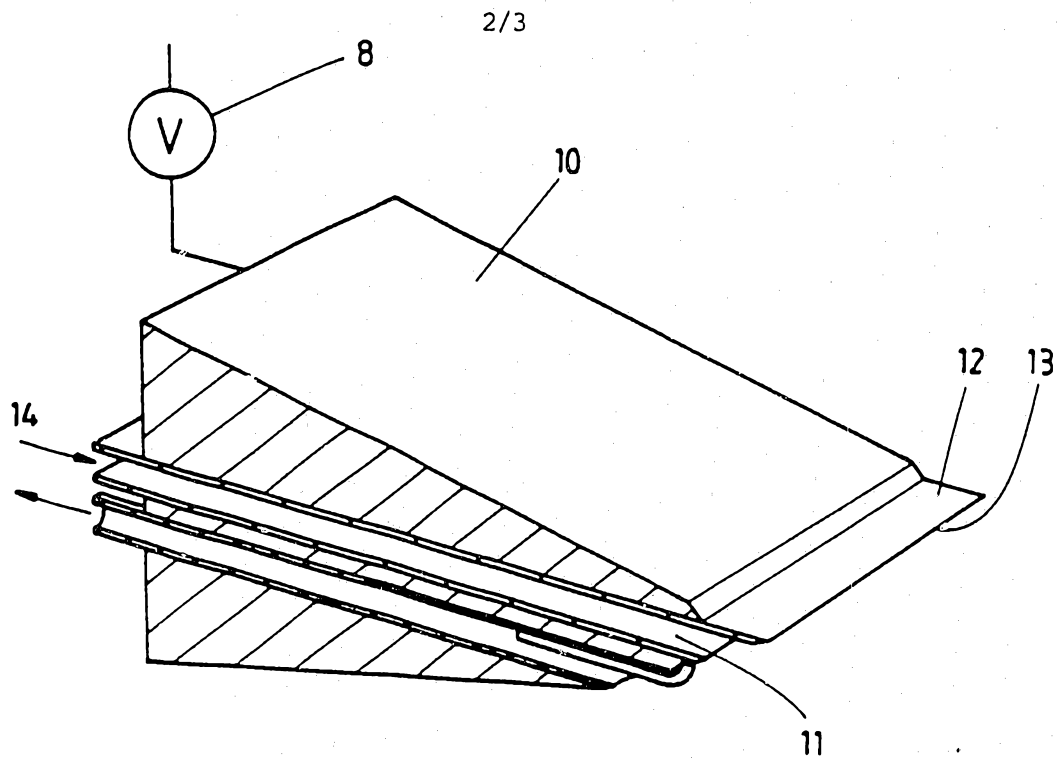

**FIG 3**

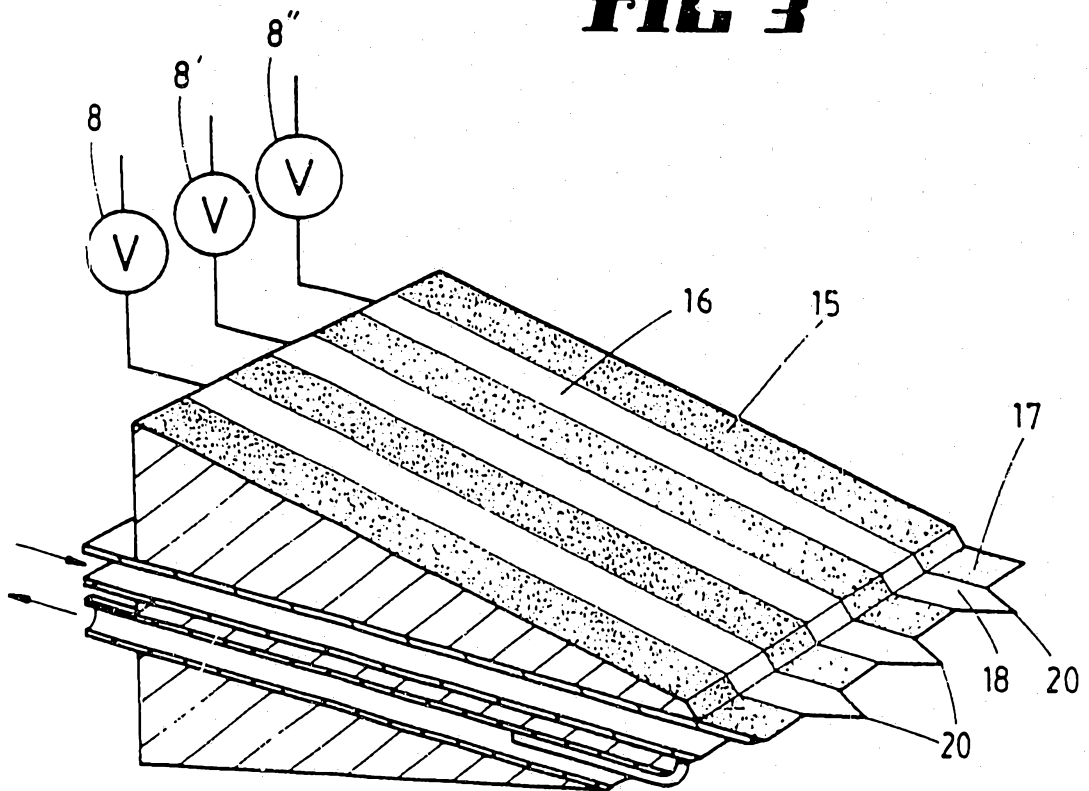

**FIG 4**

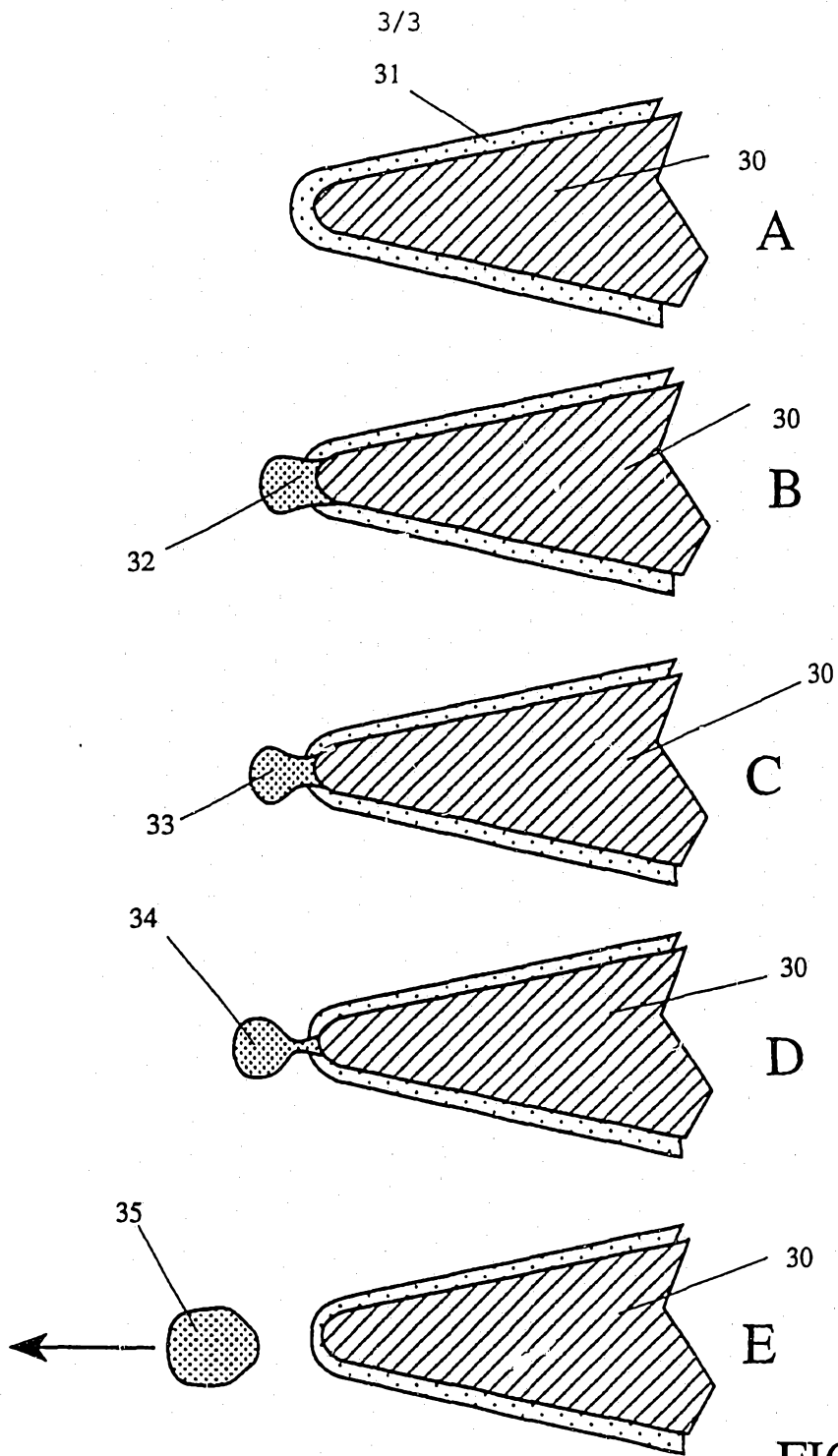
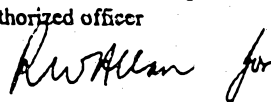

FIG 5

## INTERNATIONAL SEARCH REPORT

International application No.

PCT/AU92/00665

<b>A. CLASSIFICATION OF SUBJECT MATTER</b> Int. Cl. <sup>5</sup> B01J 2/06, B03C 5/02, B41J 2/06, 27/18  According to International Patent Classification (IPC) or to both national classification and IPC		
<b>B. FIELDS SEARCHED</b>  Minimum documentation searched (classification system followed by classification symbols) IPC B01J 2/02, 2/06, B03C 5/00, 5/02, B41J 2/06, 27/16, 27/18, 3/18 (ed 1-4)  Documentation searched other than minimum documentation to the extent that such documents are included in the fields searched AU : B01J 2/02, 2/06, B03C 5/00, 5/02  Electronic data base consulted during the international search (name of data base, and where practicable, search terms used)		
<b>C. DOCUMENTS CONSIDERED TO BE RELEVANT</b>		
Category*	Citation of document, with indication, where appropriate, of the relevant passages	Relevant to Claim No.
A	US,A, 3060429 (WINSTON) 23 October 1962 (23.10.62)	(1-5)(10-12)(15-19) (26,27)
X	US,A, 3575841 (HARRIS) 20 April 1971 (20.04.71) Col 3 lines 3-21	
A	US,A, 3980541 (AINE) 14 September 1976 (14.09.76) Fig 17	
A	US,A, 3129157 (LOECKENHOFF) 14 April 1964 (14.04.64)	
<input checked="" type="checkbox"/> Further documents are listed in the continuation of Box C.		<input checked="" type="checkbox"/> See patent family annex.
* Special categories of cited documents :		
"A"	document defining the general state of the art which is not considered to be of particular relevance	"T" later document published after the international filing date or priority date and not in conflict with the application but cited to understand the principle or theory underlying the invention
"E"	earlier document but published on or after the international filing date	"X" document of particular relevance; the claimed invention cannot be considered novel or cannot be considered to involve an inventive step when the document is taken alone
"L"	document which may throw doubts on priority claim(s) or which is cited to establish the publication date of another citation or other special reason (as specified)	"Y" document of particular relevance; the claimed invention cannot be considered to involve an inventive step when the document is combined with one or more other such documents, such combination being obvious to a person skilled in the art
"O"	document referring to an oral disclosure, use, exhibition or other means	"&" document member of the same patent family
"P"	document published prior to the international filing date but later than the priority date claimed	
Date of the actual completion of the international search 30 March 1993 (30.03.93)		Date of mailing of the international search report 5 APR 1993 (5.4.93)
Name and mailing address of the ISA/AU AUSTRALIAN PATENT OFFICE PO BOX 200 WODEN ACT 2606 AUSTRALIA  Facsimile No. 06 2853929		Authorized officer  <b>B. BOURKE</b>  Telephone No. (06) 2832138

C(Continuation). DOCUMENTS CONSIDERED TO BE RELEVANT		
Category*	Citation of document, with indication, where appropriate of the relevant passages	Relevant to Claim No.
A	US,A, 4402000 (FABEL et al.) 30 August 1983 (30.08.83) Figs 1,3	
A	US,A, 4454016 (RABINOWITZ et al.) 12 June 1984 (12.06.84)	
A	EP,A, 198661 (TOKYO ELECTRIC CO. LTD) 22 October 1986 (22.10.86)	
A	Patents Abstracts of Japan, M-1021, page 84, JP,A, 2-160557 (MINOLTA CAMERA CO. LTD) 20 June 1990 (20.06.90)	

**INTERNATIONAL SEARCH REPORT**  
 Information on patent family memb.

International application No.  
**PCT/AU92/00665**

This Annex lists the known "A" publication level patent family members relating to the patent documents cited in the above-mentioned international search report. The Australian Patent Office is in no way liable for these particulars which are merely given for the purpose of information.

Patent Document Cited in Search Report		Patent Family Member					
US	3575841	AU GB	60966/69 1215907	DE IT	1948161 1028002	FR	2018880
US	4402000	AU DE IT	56730/80 3010981 1143123	BR FR JP	8001723 2451828 55127578	CA GB SE	1142996 2045170 8002128
EP	198661	JP	61235157	US	4760204		