



- (51) International Patent Classification:
A47J 31/42 (2006.01)
- (21) International Application Number:
PCT/US2012/044286
- (22) International Filing Date:
27 June 2012 (27.06.2012)
- (25) Filing Language:
English
- (26) Publication Language:
English
- (30) Priority Data:
13/230,954 13 September 2011 (13.09.2011) US
- (71) Applicant (for all designated States except US): **CONAIR CORPORATION** [US/US]; One Cummings Point Road, Stamford, Connecticut 06902 (US).
- (72) Inventors; and
- (75) Inventors/Applicants (for US only): **LAI, Kin Man** [CN/CN]; Room 3121, Ming Yan Lau, Jat Min Chuen, Shatin, N.T., Hong Kong (CN). **FUNG, Kam Fai** [CN/CN]; Block 3, Flat B, 16th Floor, Melody Garden,

Tuen Mun, Hong Kong (CN). **SCHNABEL, Barbara Lynn** [US/US]; 42 Hollow Oak Road, Chappaqua, New York 10514 (US). **ORENT, Jill Frances Kreutzer** [US/US]; 89 Old Hill Road, Westport, Connecticut 06880 (US).

(74) Agent: **TUCCILLO, Nicholas**; McCormick, Paulding & Huber LLP, CityPlace II, 185 Asylum Street, 18th Floor, Hartford, Connecticut 06103 (US).

(81) Designated States (unless otherwise indicated, for every kind of national protection available): AE, AG, AL, AM, AO, AT, AU, AZ, BA, BB, BG, BH, BR, BW, BY, BZ, CA, CH, CL, CN, CO, CR, CU, CZ, DE, DK, DM, DO, DZ, EC, EE, EG, ES, FI, GB, GD, GE, GH, GM, GT, HN, HR, HU, ID, IL, IN, IS, JP, KE, KG, KM, KN, KP, KR, KZ, LA, LC, LK, LR, LS, LT, LU, LY, MA, MD, ME, MG, MK, MN, MW, MX, MY, MZ, NA, NG, NI, NO, NZ, OM, PE, PG, PH, PL, PT, QA, RO, RS, RU, RW, SC, SD, SE, SG, SK, SL, SM, ST, SV, SY, TH, TJ, TM, TN, TR, TT, TZ, UA, UG, US, UZ, VC, VN, ZA, ZM, ZW.

[Continued on next page]

(54) Title: BREWED BEVERAGE APPLIANCE AND METHOD

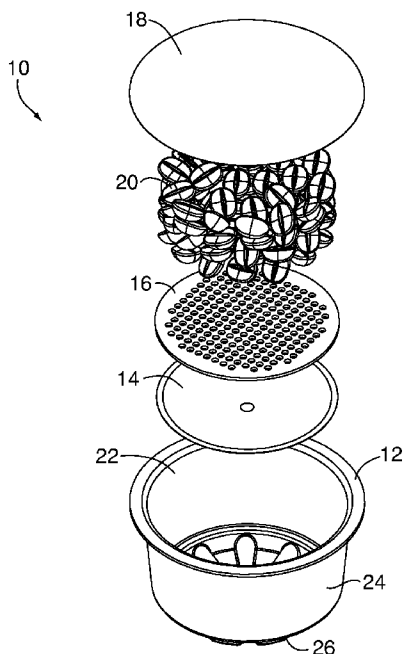

FIG. 1

(57) Abstract: A beverage assembly includes a housing having a liquid reservoir, an inlet portion formed in the housing, a beverage container configured to be removably accommodated within the inlet portion and having a fracturable seal and containing a beverage ingredient of a first size, a grinding mechanism positioned within the housing and in fluid communication with the inlet portion, and a piercing assembly positioned within the housing, wherein the piercing assembly selectively pierces the fracturable seal thereby causing said beverage ingredient to enter the grinding mechanism. The grinding mechanism selectively transforms the beverage ingredient from the first size to a second size, the second size being smaller than the first size. The beverage assembly further includes a brewing area disposed beneath the grinding assembly and configured to removably accommodate the beverage container after the beverage container has been pierced by the piercing assembly.

WO 2013/039591 A1



(84) Designated States (*unless otherwise indicated, for every kind of regional protection available*): ARIPO (BW, GH, GM, KE, LR, LS, MW, MZ, NA, RW, SD, SL, SZ, TZ, UG, ZM, ZW), Eurasian (AM, AZ, BY, KG, KZ, RU, TJ, TM), European (AL, AT, BE, BG, CH, CY, CZ, DE, DK, EE, ES, FI, FR, GB, GR, HR, HU, IE, IS, IT, LT, LU, LV, MC, MK, MT, NL, NO, PL, PT, RO, RS, SE, SI, SK,

SM, TR), OAPI (BF, BJ, CF, CG, CI, CM, GA, GN, GQ, GW, ML, MR, NE, SN, TD, TG).

Published:

- *with international search report (Art. 21(3))*
- *with amended claims and statement (Art. 19(1))*

BREWED BEVERAGE APPLIANCE AND METHOD

TECHNICAL FIELD

5 The present invention relates to brewed beverage appliances and, more particularly, to a brewed beverage appliance adapted to brew coffee from a pre-packaged, disposable container and filter combination.

BACKGROUND OF THE INVENTION

10 Various known coffee making appliances involve adding of coffee beans in one of various forms (i.e., ground or unground) to a container that is part of a machine in which heated water is delivered to the container and passes therethrough. The container typically includes a filtering mechanism so that heated water exiting the
15 container is in the form of brewed coffee. Certain appliances require pre-ground coffee beans to be added in the form of "grounds." Other appliances are designed to accept whole coffee beans into a hopper or opening and include mechanisms that grind the beans into a ground form and then complete the brewing process. It is sometimes preferred to keep whole beans on hand for making coffee so that the coffee may be
20 ground immediately prior to brewing, as this is believed to produce the freshest tasting coffee beverage. Yet other appliances required use of pods or pre-packaged coffee grounds in a serving-sized filter container to be inserted into the appliance. In such instances, the pre-packaged pods or containers are limited to being filled with ground
25 coffee. Certain pre-packaged containers require placement into a separate filter mechanism in the appliance, while others have built-in filtering mechanisms.

SUMMARY OF THE INVENTION

30 It is an object of the present invention to provide a beverage making appliance and related method that include the benefits of brewing coffee from whole beans that are ground immediately before brewing and that are contained in a convenient, disposable, single-serving package.

 These and other objects are achieved by the present invention.

In an embodiment, a beverage assembly includes a housing having a liquid reservoir and an inlet portion formed in the housing. The assembly also includes a beverage container configured to be removably accommodated within the inlet portion. The beverage container has a fracturable seal and contains a beverage ingredient of a first size. A grinding mechanism is positioned within the housing and is in fluid communication with the inlet portion. A piercing assembly is positioned within the housing. The piercing assembly selectively pierces the fracturable seal thereby causing said beverage ingredient to enter the grinding mechanism and the grinding mechanism selectively transforms the beverage ingredient from the first size to a second size, the second size being smaller than the first size. A brewing area is disposed beneath the grinding assembly and is configured to removably accommodate the beverage container after the beverage container has been pierced by the piercing assembly. Liquid from the liquid reservoir is directed to the beverage container after the beverage ingredient of the second size has passed from the grinding mechanism into the beverage container such that the liquid exits an outlet of the beverage container after passing through the beverage ingredient of the second size.

BRIEF DESCRIPTION OF THE DRAWINGS

FIG. 1 is an exploded view of a whole coffee bean pre-packaged filter cup according to the present invention.

FIG. 2 is a perspective top view of the whole coffee bean pre-packaged filter cup of FIG. 1.

FIG. 3 is a perspective bottom view of the whole coffee bean pre-packaged filter cup of FIG. 1.

FIG. 4 is a top plan view of the whole coffee bean pre-packaged filter cup of FIG. 1.

FIG. 5 is a bottom plan view of the whole coffee bean pre-packaged filter cup of FIG. 1.

FIG. 6 is a side elevational view of the whole coffee bean pre-packaged filter cup of FIG. 1.

FIG. 7 is a side cross-sectional view of the whole coffee bean pre-packaged filter cup of FIG. 1 taken along line A-A of FIG. 6.

FIG. 8 is an exploded view of a whole coffee bean pre-packaged filter cup according to another embodiment of the present invention.

FIG. 9 is a perspective right side view of a coffee appliance according to the present invention.

5 FIG. 10 is a perspective left side view of the coffee appliance of FIG. 9.

FIG. 11 is a left side elevational view of the coffee appliance of FIG. 9.

FIG. 12 is a front elevational view of the coffee appliance of FIG. 9.

FIG. 13 is a right side elevational view of the coffee appliance of FIG. 9.

FIG. 14 is a rear elevational view of the coffee appliance of FIG. 9.

10 FIG. 15 is a top plan view of the coffee appliance of FIG. 9.

FIG. 16 is a bottom plan view of the coffee appliance of FIG. 9.

FIG. 17 is a perspective view of the coffee appliance of FIG. 9 illustrating a ready mode thereof.

15 FIG. 18 is a perspective view of the coffee appliance of FIG. 9 illustrating the loading of the whole coffee bean pre-packaged filter cup of FIG. 1.

FIG. 19 is a perspective view of the coffee appliance of FIG. 9 illustrating the whole coffee bean pre-packaged filter cup of FIG. 1 in a loading tray.

FIG. 20 is a perspective view of the coffee appliance of FIG. 9 in a loaded state.

20 FIG. 21 is a perspective view of the coffee appliance of FIG. 9 in a brew-ready state.

FIG. 22 is a perspective view of the coffee appliance of FIG. 9 during brewing/operation.

FIG. 23 is a perspective view of the coffee appliance of FIG. 9 subsequent to brewing a cup of coffee.

25 FIG. 24 is a perspective view of the coffee appliance of FIG. 9 illustrating the removal of a spent pre-packaged filter cup subsequent to brewing.

FIG. 25A is a schematic view of the whole coffee bean pre-packaged filter cup of FIG. 1 illustrating water flowing through during a brewing mode.

30 FIG. 25B is a bottom plan view of a shower head for distributing heated water to the whole coffee bean pre-packaged filter cup of FIG. 1 in accordance with the present invention.

FIG. 26 is a first, side cross-sectional view of the coffee appliance of FIG. 9 in a first mode.

FIG. 27 is a second, side cross-sectional view of the coffee appliance of FIG. 9 in a first mode.

FIG. 28 is a first, side cross-sectional view of the coffee appliance of FIG. 9 shown in a second mode.

5 FIG. 29 is a second, side cross-sectional view of the coffee appliance of FIG. 9 shown in a second mode.

FIG. 30 is a detail schematic view of a grinding motor and grinding blade assembly of the coffee appliance of FIG. 9.

10 FIG. 31 a cross-sectional, schematic view of the coffee appliance of FIG. 9 in a mode of operation.

FIG. 32 a cross-sectional, schematic view of the coffee appliance of FIG. 9 in another mode of operation.

FIG. 33 a cross-sectional, schematic view of the coffee appliance of FIG. 9 in another mode of operation.

15 FIG. 34 is an enlarged, detail view of a filter cup lifting mechanism and grinding motor of the coffee appliance of FIG. 9.

FIG. 35 is an enlarged, cross-sectional, schematic view of the coffee appliance of FIG. 9 in a mode of operation.

20 FIG. 36 is an enlarged, cross-sectional, schematic view of the coffee appliance of FIG. 9 in another mode of operation.

FIG. 37 is an enlarged, cross-sectional, schematic view of the coffee appliance of FIG. 9 in a mode of operation.

FIG. 38 is a perspective view of a grinding blade assembly for use with the coffee appliance of FIG. 9, in accordance with the present invention.

25 FIG. 39 is a top plan view of the grinding blade assembly of FIG. 38

FIG. 40 is a left side elevational view of the grinding blade assembly of FIG. 38.

FIG. 41 is a front elevational view of the grinding blade assembly of FIG. 38.

FIG. 42 is a right side elevational view of the grinding blade assembly of FIG. 38.

30 FIG. 43 is a side cross-sectional view of grinding blade assembly of FIG. 38, taken along line A-A of FIG. 41.

FIG. 44 is a schematic view of a blade assembly and the whole coffee bean pre-packaged filter cup of FIG. 1 shown in a first position.

FIG. 45 is a schematic view of a blade assembly and the whole coffee bean pre-packaged filter cup of FIG. 1 shown in a second position.

FIG. 46 is a schematic view of a blade assembly and the whole coffee bean pre-packaged filter cup of FIG. 1 shown in a third position.

5 FIG. 47 is a schematic view of a blade assembly and the whole coffee bean pre-packaged filter cup of FIG. 1 shown in a fourth position.

FIG. 48 is an enlarged schematic view of the coffee appliance of FIG. 1 in a grinding mode.

10 FIG. 49 is a cross-sectional view of the coffee appliance of FIG. 1 in a grinding mode, taken along line B-B of FIG. 48.

FIG. 50 is an enlarged schematic view of the coffee appliance of FIG. 1 subsequent to grinding coffee beans.

FIG. 51 is an enlarged schematic view of the grinding blade of the coffee appliance of FIG. 1 grinding a coffee bean according to the present invention.

15 FIG. 52 is a perspective front view of an alternative grinding blade assembly for use with the coffee appliance of FIG. 9, in accordance with another embodiment present invention.

FIG. 53 is a perspective rear view of the alternative grinding blade assembly of FIG. 52.

20 FIG. 54 is a top plan view of the alternative grinding blade assembly of FIG. 52.

FIG. 55 is a left side elevational view of the alternative grinding blade assembly of FIG. 52.

FIG. 56 is a front elevational view of the grinding blade assembly of FIG. 52.

FIG. 57 is a right side elevational view of the grinding blade assembly of FIG. 52.

25 FIG. 58 is a schematic, cross-sectional view of the coffee appliance of FIG. 9 illustrating a flow of water from a reservoir through the pre-packaged filter cup of FIG. 1.

FIG. 59 is a schematic, cross-sectional view of the coffee appliance of FIG. 9 illustrating a cleaning mode.

30 FIG. 60 is a perspective view of a water reservoir of the coffee appliance according to the present invention.

FIG. 61 is a bottom plan view of a portion of the coffee appliance of FIG. 9

FIG. 62 is a perspective view of a tray for receiving the whole coffee bean pre-packaged filter cup of FIG. 1.

FIG. 63 is a side, cross-sectional view of the tray of FIG. 62.

FIG. 64 is a bottom plan view of the tray of FIG. 62.view of a tray component of
5 an appliance according to the present invention.

FIG. 65 is a perspective view of a coffee appliance having a slidable drip tray according to the present invention.

FIG. 66 is a cross-sectional view of the coffee appliance of FIG. 65 showing the slidable drip tray in an extended position.

10 FIG. 67 is a cross-sectional view of the coffee appliance of FIG. 65 showing the slidable drip tray in a retracted position.

FIG. 68 is a schematic view of a coffee appliance according to another embodiment of the present invention.

15 FIG. 69 is a schematic view of a coffee appliance in accordance with another embodiment of the present invention, illustrating a grinding motor in a first position.

FIG. 70 is a schematic view of the coffee appliance of FIG. 69 illustrating the grinding motor in a second position.

FIG. 71 is a schematic view of a coffee appliance in accordance with another embodiment and in a first mode of operation.

20 FIG. 72 is a schematic view of the coffee appliance of FIG. 71, in a second mode of operation.

FIG. 73 is a schematic view of the coffee appliance of FIG. 71, in a third mode of operation.

25 FIG. 74 is a schematic view of the coffee appliance of FIG. 71, in a fourth mode of operation.

FIG. 75 is a schematic view of the coffee appliance of FIG. 71, in a fifth mode of operation.

FIG. 76 is a schematic view of the coffee appliance of FIG. 71, in a sixth mode of operation.

30 FIG. 77 is a schematic view of the coffee appliance of FIG. 71, in a seventh mode of operation.

FIG. 78 is a schematic view of the coffee appliance of FIG. 71, in an eighth mode of operation.

FIG. 79 is a schematic view of the coffee appliance of FIG. 71, in a ninth mode of operation.

FIG. 80 is a perspective view of a brewing cartridge of the coffee appliance of FIG. 71.

5 FIG. 81 is a top plan view of the brewing cartridge of FIG. 80.

DETAILED DESCRIPTION OF THE PREFERRED EMBODIMENTS

Referring to FIGS. 1 - 7, a filter cup 10 for use with an appliance according to the present invention includes a cup 12, a paper/fabric filter 14, a plastic screen 16 and a foil cover 18. The filter 14 prevents coffee grounds and/or other sediment from exiting the cup 12 during brewing but permits passage of liquid. The cover 18 may be formed from aluminum or other material known in the art, and is preferably heat-sealed or otherwise releasably affixed to the top rim of the cup 10. A plurality of whole coffee beans 20 are enclosed in the space between the foil cover 18 and the plastic screen 16. While FIG. 1 shows coffee beans housed in the filter cup 10, other types of food and substances, such as tea and the like, may be used in similar fashion to that described herein, without departing from the broader aspects of the present invention.

As further shown in FIG. 1, the cup 12 has an opening 22 at the top thereof, a circumferential sidewall 24 and a floor 26. As best shown in FIGS. 2-7, the floor 26 has a plurality of grooves or channels 28 that direct a flow of fluid to a circular depression or recess 30 having one or more apertures 32. Importantly, the recess 30 is the lowest portion of the cup 10 such that brewed coffee collects in the recess 30 and exits the cup through the apertures 32, as discussed hereinafter. FIG. 7 illustrates the cup 10 in an assembled state and containing coffee beans 20. As shown therein, the paper filter 14 is positioned on the floor 26 of the cup 12. The plastic screen 16 is positioned on top of the paper filter 14 and protects the paper filter 14 from abrasion caused by a grinding blade and/or coffee grounds. Both the paper filter 14 and the screen 16 are circular and sized to be closely received by the circumferential sidewall 24 of the cup at the bottom thereof. As best shown in FIG. 7, the screen 16 may be resilient and resistant to bending such that the screen 16 provides a flat surface in the cup 12 on top of which coffee bean 20 may rest. Importantly, the screen 16 prevents the coffee beans 20 from falling to the floor 26 of the cup 12 (which may be out of reach of a grinding blade) to facilitate

optimal grinding by the grinding blade, as discussed in detail hereinafter. As discussed above, the foil cover 18 seals the filter 14, screen 16 and coffee beans 20 inside the cup 12.

The cup 10 may be stored and transported in a separate sealed package or wrapper for additional freshness and protection, and the apertures 32 in the floor 26 may be covered with, for example, an adhesive label (not shown). In the preferred embodiment, the filter cup 10 is a pre-packaged, single-use, disposable component. Thus, it is sealed by the foil cover 18 in an air-tight manner to preserve freshness and flavor and to protect the coffee beans 20 from moisture and contamination. As discussed above, the filter cup 10 may be sealed by the foil cover 18 and an adhesive label, or may be packaged in a wrapper with or without the adhesive label. In an alternative embodiment, it is contemplated that the filter cup 10 may instead be a re-usable cup that is re-filled for each use. In an embodiment, the floor 26 of the cup may be formed without apertures 32. In this embodiment, the floor of the cup 26 may be pierced by a needle upon insertion into a coffee appliance to provide an exit for the flow of brewed coffee.

Referring now to FIG. 8, an alternative construction of a filter cup 50 is shown. As shown therein, the cup 50 is substantially similar in shape and construction as the cup 10, however, a metal mesh filter 52 may be utilized in place of the paper/fabric filter 14 and the protective plastic screen 16. In this embodiment, the metal mesh filter 52 is fine enough such that it prevents coffee grounds from exiting the cup 10 and also provides a level of abrasion resistance. While it is disclosed that the filter 34 may be formed from a metal mesh, other materials substantially resistant to abrasion from the grinding blade and/or coffee grounds may also be utilized without departing from the broader aspects of the present invention.

Referring to FIGS. 9-24, an appliance 100 according to an embodiment of the present invention is shown. The appliance 100 is intended to be used in combination with the filter cup 10, disclosed above, in order to brew a coffee or other beverage. As shown therein, the appliance 100 is generally rectangular in shape and comprises a base 102 and a drip tray housing 104 slidably receiving a drip tray 106 having a slotted or grated top surface 108. The surface 108 of the tray 106 is adapted to have a container, such as a coffee mug 109, placed upon it to receive brewed coffee as it is produced by and emitted from the appliance 100. As will be readily appreciated, the slotted surface

108 permits liquid that may be spilled from the cup 109 or that miss the cup 109 during operation to pass through the surface 108 and collect in the drip tray 106, for easy cleanup.

A housing 110 is located above, and supported by, the base 102 and slidably
5 receives a filter cup housing/tray 112 for securing and positing the filter cup 10 during use. A handle 114 is pivotally mounted to the housing 110 for operation, as described below. As further shown in FIGS. 9 and 10, a water reservoir 116 is attached to, supported by, and otherwise forms a part of the housing 17. In an embodiment, the water reservoir 116 may be removably or permanently mounted to the housing 110.
10 The housing 110 also includes a control panel 118 for controlling operational features of the appliance, as discussed hereinafter. As best shown in FIG. 9, the base 102 includes a recess on one side there for slidably receiving a discard tank 120 for receiving water from a cleaning operation of the appliance 100 (described below) and discarded filter cups 10 after use. In an alternative embodiment, the tray 112 may be pivotally received
15 by the housing 110 and movable between a first position in which the housing/tray 112 is received within the housing, and a second position in which the tray 112 is pivoted away from the housing and towards a user to facilitate the installation of a filter cup 10. In an embodiment, the tray 112 is removable from the housing 110 for cleaning.

Operation of the appliance 100 will now be described with specific reference to
20 FIGS. 17-24. First, the water reservoir 116 is filled with water. A user then selects the desired coffee settings from the control panel 118. Settings may include selectable options such as coffee strength and serving size, timer setting, automatic brew, etc. The handle 114 is then moved upwardly in the direction of arrow *A*, as shown in FIG. 17, in order to unlock the tray 112 from its seated and retained position within the housing
25 110. The tray 112 slides out from the appliance 100 in the direction of arrow *B* to the position shown in FIG. 18, under force of a spring 154. In this position, the tray 112 is ready for a filter cup 10 to be placed into the receiving bracket 124 in the tray 112.

After the cup 10 is inserted into the tray 112, the tray 112 is now ready to be pushed back into the appliance 100 in the direction of arrow *C*, as shown in FIG. 19. In
30 particular, the tray 112 is pushed manually back into the appliance 100 so that it is received by the housing 110 in locked position, as shown in FIG. 20. The handle 114 is then lowered in the direction of arrow *D* in order to automatically initiate the grinding and brewing processes.

Referring to FIG. 21, as noted above, the grinding process starts automatically after the handle 114 is lowered. In the process, the coffee beans 20 in the filter cup 10 are ground by a grinding blade 126 that is received within the cup 10 so that the beans 20 are turned into coffee grounds 128. After grinding is completed, heated water is delivered into the cup 10 from a water outlet described hereinafter. As represented by the arrow 130 in FIG. 22, coffee is emitted from the bottom of the tray 112, which has an opening to enable such emission, into the coffee mug 109 positioned beneath the tray 112.

After the brewing process is complete, the handle 114 is raised from the position shown in FIG. 23 in the direction of arrow *E* to the position shown in FIG. 24. Again, movement of the handle 114 to its upper position unlocks the tray 112 so that it slides out of the housing 110 appliance 100, permitting the user to manually remove the used filter cup 10 from the tray 112. The cup 110 may then be discarded into the discard tank 120. The filled mug 109 of coffee may be removed from the drip tray 106 before or after this step.

In an embodiment, while the tray 112 is in the out position, as shown in FIG. 24, a blade cleaning operation automatically begins. In the blade cleaning operation water is emitted from the water outlet 132. Because the cup 10 has been removed, the blade is surrounded by space thereby enabling the flowing water to rinse it clean. In an embodiment, the blade may rotate during application of water to facilitate cleaning. Since the tray 112 is in the out position, the water will not drain out of the bottom of the cup 10 and tray 112, as it does in the brewing mode. Instead, the water is diverted because it falls into the rear end 134 of the tray 112 into a collection pan 136, as is shown in FIG. 59. The water exits from the collection pan 136 of the tray 112 via a discard tube 138 and falls into the discard tank 120.

In an alternative embodiment, a cup containing a cleaning liquid such as water may be utilized to clean the blade 166 either periodically or after each use. In this embodiment, a cleaning cup is inserted into the receptacle 124 and the appliance 100 is actuated by pulling the handle 114 downward. The appliance 100 may then run a normal brewing cycle. Alternatively, a button on the control panel 118 may be depressed to run a cleaning cycle. The cleaning cycle may be specifically configured, e.g., water temperature, run time, blade rotation speed, to optimize blade cleaning and sterilization. In alternative embodiments, the cleaning cup may contain a cleaning

solution or a slurry of cleaning ingredients. The cleaning ingredients may be liquid or dry and may take the form of granules, powder, etc.

In yet another embodiment, a cleaning operation may including running a brewing cycle without actually inserting a filter cup 10. In this embodiment, the handle 114 may be moved downward to begin the cycle such that heated water is passed over the stationary or rotating blade 166 to clean the blade. Alternatively, a button on the control panel 118 may be depressed to initiate the cleaning cycle.

FIGS. 62 and 63 illustrate the tray 112 and the collection pan 136. FIG. 64 illustrates the bottom view of the tray 112 and shows the openings 32 of the cup 10 as viewed through an opening 140 in the bottom of the tray 112 that permits brewed coffee to flow out.

FIG. 25A schematically illustrates how ground coffee 128, which is ground from whole coffee beans 20 in a procedure described below, is infused with heated water to produce coffee. The ground coffee 128 is located in the cup 10 and heated water is introduced from above through a water outlet 132 as indicated by the arrow 142. The heated water flows through the ground coffee 128 in the cup 10 and exits from the apertures 32 in the bottom of the cup 10 as shown by arrow 144.

FIGS. 26 and 27 illustrate certain internal components of the appliance 100. As shown therein, the water reservoir 116 is filled with water. The tray 112 is withdrawn to permit placement of a cup 10 into a receiving bracket 124 in the tray 112, as shown in FIGS. 18 and 19. The tray 112 is then pushed back into the appliance to the position shown in FIG. 20. The handle 113 is then moved downwardly, as shown in FIGS. 21 and 22. Such movement of the handle 114 causes the cup 10 to be raised upwardly for grinding of the coffee beans 20 in the cup 10, as described below. The appliance 100 includes a heater 146 and pump 148 to heat water from the reservoir 116 and route it through a supply conduit to perform a brewing operation as described with reference to FIG. 25A. As shown in FIGS. 26-29, a grinder motor 150 is positioned in the housing 110 of the appliance 100 to carry out grinding of the coffee beans 20 in a manner described below. A hot water tube 152 carries heated water from the heater 146 to the water outlet 132 located above the tray 112.

As best shown in FIGS. 27 and 29, lifting mechanism 156 is activated by the handle 114 in order to cause movement of the cup 10 between a lowered position and a raised position. The mechanism 156 includes a linkage arm 158, a pin 160 operatively

attached to the receiving bracket 124 of the tray 112 and associated slot 162, and a plate 164 in which the slot 162 is located. In operation, upon moving the handle 114 in the downwards direction, pin 160 follows the path of the slot 162 and causes the cup 10 and the receiving bracket 124 to be lifted upwards into the grinding blade. Guideposts 161
5 are received in bore holes 163 of the receiving bracket to ensure proper orientation and alignment of the cup 10 with the grinding blade. Lowering of the cup 10 follows the reverse process.

Referring to FIG. 30, the appliance 100 includes a grinding blade 166 attached to and driven by a rotary output shaft 168 associated with the grinder motor 150. When
10 the handle 112 is moved to the lower position as shown in FIG. 28, the cup 10 is raised so that the blade 166 engages and pierces through the foil cover 18 and enters the cup 10 and comes into contact with the coffee beans 20. The cup loading/raising mechanism 156, which is activated by the handle 114, moves the cup 10 between this raised position for grinding, and a lowered position. The spring 154 is a user assist spring, which
15 biases the tray 112 outwards from the housing 110 when the handle 114 is raised, in order to insert a cup 10.

As shown in FIG. 31, movement of the handle 114 to the raised position unlocks the tray 112 so it slides out under force of the spring 154 in cooperation with a plate 165 (which serves as an anchoring object for the spring to work off of) in order to allow
20 placement of a cup 10 into the receiving bracket 124 of the tray 112. A user then places a cup 10 into the tray 112 as shown in FIG. 32. The tray 112 must be manually pushed back into the closed position as shown in FIG. 33 until it locks in place by the tray lock 170 shown in FIG. 34.

FIGS. 35-37 illustrate the piercing and grinding sequence in accordance with the
25 present invention. As shown in FIG. 35, the filter cup 10 is raised upwardly toward the blade 166, in the direction of arrow *F* when the handle 114 is lowered. FIG. 36 illustrates the position of the cup 10 when it is fully raised. In that position, a seal ring 172, such as an O-ring, engages a top rim of the cup 10 so that when the brewing process occurs the cup 10 may be pressurized. FIG. 37 illustrates the lowered position
30 of the cup 10 after grinding and brewing occur and the handle 114 is raised. Importantly, the seal ring 172 seals the top of the cup 10 so that the cup may be pressurized. In the preferred embodiment, the cup is pressurized in excess of 200

kilopascals (2 bars) during brewing, although other pressures may be employed without departing from the broader aspects of the present invention.

Various views of the grinding blade 166 for grinding the whole coffee beans are shown in FIGS. 38-43. As shown therein, the blade 166 has a V-shaped configuration. Importantly, the blade 166 has insert cutting edges 174 so that the foil cover 18 of the cup 10 can be pierced when the cup 10 is raised upon downwards movement of the handle 114. The top of the blade also includes upward facing extract cutting edges 176 for cutting through the foil cover 18 when the cup 10 is lowered away from the blade subsequent to brewing, upon upwards movement of the handle 114. Each leg of the "V" is also formed with an opposed recess 178 and raised ridge 180 to facilitate grinding of the coffee beans 20, as described hereinafter. The blade 166 also includes a collar 182 for connection to the output shaft 168 of the grinding motor 150. In such an embodiment, the blade 166 may be removable for replacement and/or more thorough cleaning. In an alternative embodiment, the blade 166 is integrally formed or otherwise fixedly secured to the output shaft 168 of the motor 150. As will be readily appreciated, the slim profile of the blade 166 puts cuts a slot a minimal width in the foil cover 18 to prevent coffee grounds 128 from being thrown out of the cup 10 during grinding. In addition, the shape and configuration of the blade 166 facilitates cleaning.

FIG. 44 illustrates the cup 10 being raised toward the blade 166 and FIG. 45 illustrates the blade 166, by way of the insert cutting edges 174, piercing the foil cover 18 of the cup 10. In both FIGS. 44 and 45 the coffee beans 20 in the cup 10 are not yet ground. After grinding, the beans 20 have been transformed into ground coffee 128. Brewing occurs, as described above, and the cup 10 is then lowered as shown in FIGS. 46 and 47 such that the extract cutting edges 176 of the blade 166 again pierce the foil cover 18, if necessary, to facilitate removal of the cup 10 from the blade 166.

Referring now to FIGS. 48-50, the actual grinding process is illustrated. Upon actuation of the grinding motor 150, the grinding blade 166 rotates at a high frequency sufficient to grind the coffee beans 20 in the filter cup 20 to transform the coffee beans 20 from whole beans, as shown in FIG. 48, to grinds, as shown in FIG. 60. In particular, the blade 166 is rotated in a direction (see FIG. 49) that causes the ridge 180 on the blade 166 to strike/impact the coffee beans 20 to cause them to split. Over time, numerous impacts from the blade itself, and most importantly, by the ridges 180, gradually reduce the size of the coffee beans to fine grounds sufficient for brewing. In an embodiment,

the blade 166 may continue to rotate at a predetermined frequency during the brewing process, i.e., during the time during which hot water is passed through the cup 12. The frequency of rotation during brewing may be the same as, or different from, the frequency utilized to grind the coffee beans 20. In other embodiments, the blade 166
5 may be utilized to stir drink ingredients during brewing, such as to facilitate dissolution of drink ingredients into the water passing through the cup 10 (e.g., when utilizing iced tea drink ingredients in place of whole coffee beans). As will be readily appreciated, stirring the drink ingredients/coffee beans within the cup 10 while brewing may produce a better tasting beverage. In particular, stirring during brewing may improve
10 the contact between the coffee grounds 128 and the hot water, which may improve coffee quality and/or concentration.

In an alternative embodiment, the filter cup 10 may be retracted from the grinding blade 166 prior to distributing heated water to the cup 10. As will be readily appreciated, this ensures that the grinding blade 166 only touches the coffee when it is
15 dry (i.e., when it grinds the coffee beans 20 prior to brewing). Accordingly, grounds coffee is not as susceptible to sticking to the blade 166 as it would be if the blade 166 and ground coffee 128 were present together in a wet environment and, as such, keeps the blade substantially free of coffee grounds without having to clean the blade.

FIGS. 52-57 illustrate an alternative configuration for a grinding blade 184 that
20 may be utilized with the appliance 100. As shown therein, the blade has a V-shaped configuration and has a piercing edge 186 for piercing the foil cover 18 of the cup 10. The blade 184 also has two horizontally extending flanges 188, 190 to facilitate grinding of the coffee beans 20 and two upward edges 192, 194 for again cutting through the foil 18 when the cup 10 is lowered away from the blade 184. As with the blade 166 of the
25 preferred embodiment, the blade 184 may be releasably attached to the output shaft 168 of the grinding motor 150, or it may be integrally formed or otherwise permanently affixed thereto.

The path of water used in the process of the present invention is illustrated in FIG. 58. First, the reservoir 116 is filled with water. In an embodiment, the reservoir
30 116 may be releasably received on the housing 110 such that a user can remove the reservoir 116 to fill it with water and then place it on the housing 110. As will be readily appreciated, such a configuration may be easier than bring a water source to the reservoir itself. The reservoir 116 may have a removable lid 194 as shown in FIG. 60 to

facilitate filling with water. A water outlet 196, best shown in FIGS. 17-24, permits water to flow from the reservoir 116 under the force of gravity. The outlet 196 may be equipped with a valve 198 of a type commonly known to those skilled in the art, wherein the valve may be electronically activated and controlled by means of a conventional controller from an open position to a closed position, and vice versa. During brewing, water exits the reservoir 116 through the outlet 196 and travels through a first tube 200 until it reaches the pump 148. The pump 148 pumps the water through the heater 146 in order to heat the water to a desired, predetermined temperature. The water passes from the heater 146 through the hot water supply tube 152 to the water outlet 132.

In an embodiment, at the end of the brewing process, the flow of water will be shut off prior than the heater such that steam will be generated to push or blow out excess liquid remaining in the cup 10. As will be readily appreciated, this steam blast ensures that the last few drops of coffee do not remain in the cup 10 and prevents dripping.

As shown in FIG. 25B, in an embodiment, the water outlet 132 is a shower head in the form of an annular tube or ring 208 having a plurality of apertures 210 formed therein for distributing heated water. Heated water emitted from the apertures 210 of the shower head 132 is used both for brewing coffee and for rinsing the blade 166 in the cleaning operation. During brewing the heated water leaving the water outlet/shower head 132 enters the cup 10 which, at this point in the process, contains ground coffee 128. The water, now brewed coffee, exits the cup 10 through the apertures 32 in the floor 26 of the cup 10. As it exits the cup through the apertures 32, it travels down through an exit conduit in the tray 112 before emitting through the tray exit 202. In an embodiment, the tray may include a flow softening member 204 directly below the apertures 32 of the filter cup 10. The flow softening member retards the direct flow of brewed coffee into the coffee mug 109 so that the brewed coffee doesn't gush out and splash a user or create a mess. After leaving the exit 202, the water, which has now become brewed coffee, falls into the coffee mug 109. The volume of liquid selected, corresponding to the serving size, is pre-selected using the controls 118, and the pump 148 and water outlet 196 are accordingly controlled to permit flow of only the selected amount before shutting off flow.

FIGS. 65-67 illustrate an alternative configuration of the drip tray 106 in accordance with another embodiment of the present invention. As shown therein, the drip tray is moveable between a first position, as shown in FIG. 66, in which the tray 106 is positioned below the brewed coffee exit 202, and a second position, as shown in FIG. 7, in which the drip tray 106 is housed within the base 102 of the appliance 100. With the drip tray 106 in the position shown in FIG. 67, taller cups/mugs 206 may be accommodated.

FIG. 68 illustrates a coffee appliance 300 having an alternative configuration in accordance with one embodiment of the present invention. As shown therein, instead of the cup 10 being installed vertically and the grinding blade 166, brew shower head 132 and motor 150 being in a vertical position above the cup 10, these elements are oriented horizontally. In particular, as shown therein, the filter cup 10 is installed in a horizontal orientation within the housing 110. In addition, the grinding motor 150, shower head 132 and blade 166 are positioned to the side of the cup 10 in a horizontal position. In this embodiment, the appliance 300 includes a conduit 302 in communication with the bottom of the cup 10 such that brewed coffee exits the cup and is routed through the conduit 302 to the outlet 202 for distribution into a user's cup 109.

FIGS. 69 and 70 illustrate a coffee appliance 400 according to yet another embodiment of the present invention. The coffee appliance 400 is similar in configuration to that of the appliance 100 disclosed above, with a few notable differences. As shown therein, instead of the motor 150, blade 166 and shower head 132 being stationary and the cup 10 being lifted into engagement with the blade 166, in this embodiment, the brew shower head 132, motor 150 and blade 166 are configured to move towards and away from a stationary cup 10. FIG. 69 illustrates a first position of the motor 150, blade 166 and brew head 132 above the stationary filter cup 10. The motor 150, blade 166 and brew head 132 are moveable in the vertical direction to a second position, shown in FIG. 70, in which the blade is disposed within the cup 10. The vertical movement of the motor 150, blade 166 and shower head 132 may be effectuated by utilizing mechanical action or electrical actuators. The coffee appliance 400 according to this embodiment may be characterized as having an active brew assembly (motor 150, grinding blade 166 and shower head 132) and a passive filter cup 10, as opposed to an active filter cup 10 and passive brew assembly.

While the preferred embodiment contemplates the grinding and brewing of coffee from whole coffee beans, the present invention is not intended to be limited in this regard. In particular, it is contemplated that the present invention apparatus and method are not limited to cups containing whole bean coffee, per se, and the invention
5 may be used with cups containing ground coffee, partially ground coffee, tea leaves, ground tea, or drink mix ingredients. In addition, the appliance according to the embodiments of the present invention can make/brew beverages from any ingredients contained within the filter cup, and is not limited to brewing coffee from whole coffee beans.

10 FIGS. 71-79 illustrate a coffee appliance 500 in accordance with yet another embodiment of the present invention. The coffee appliance 500 is generally similar to, and contains many of the same components as, the coffee appliance 100, disclosed above, with a few notable differences. As with the coffee appliance 100, the coffee appliance 500 is intended to be used in combination with the filter cup 10, disclosed
15 above, in order to brew a coffee or other beverage. Preferably, the filter cup 10 contains whole coffee beans. As shown in FIG. 71, the coffee appliance 500 is generally rectangular in shape and includes a base 502 and a drip tray housing 504 slidably receiving a drip tray 506. As with the drip tray 106, described above, the drip tray 506 may have a slotted or grated top surface to permit liquid that may be spilled during
20 operation to pass therethrough and collect in the drip tray 506, for easy cleanup.

A housing 508 is located above, and is supported by, the base 502, and slidably receives a brewing cartridge/tray 510. In an embodiment, as best shown in FIGS. 80 and 81, the brewing cartridge 510 has a handle 512 and a generally conical chamber 514 for accommodating the filter cup 10 therein. The chamber 514 is open at the top thereof
25 to permit insertion of the filter cup 10, and has an aperture 516 at a bottom thereof for permitting brewed coffee or other brewed beverage to exit the appliance 500 through the cartridge 510. Importantly, the cartridge also has an inwardly extending flange 518 that is dimensioned to engage the underside of the rim of the filter cup 10 such that the body 12 of the filter cup 10 is positioned within the chamber 514.

30 The brewing cartridge 510 is slidably received in the housing on a pair of spaced apart, parallel rails such that the top surface of the rails engage the conical sidewalls of the brewing cartridge 510. In another embodiment, the brewing cartridge 510 may also include an outwardly extending flange such that the top surface of the rails engages the

underside of the brewing cartridge flange on opposing sides thereof to support the brewing cartridge 510. In yet another embodiment, each rail may include an inward facing, horizontal slot extending the length of the rails and dimensioned to slidably receive the outwardly extending flange of the brewing cartridge 510 therein.

5 With further reference to FIG. 71, the coffee appliance 500 also includes a water reservoir 520 that is attached to, supported by, and/or otherwise forms a part of the housing 508. In an embodiment, the water reservoir 520 may be removable from the housing 508 to facilitate water filling. The appliance 500 further includes a boiler 522 having a heater for heating water from the reservoir 520 passing therethrough, and a
10 pump 524 for pumping water from the reservoir 520, through the boiler 522, through a hot water supply conduit 526, and to a hot water outlet. In an embodiment, the pump 524 is a solenoid pump. The water outlet is preferably in the form of a shower head 528 and is disposed above the filter cup 10 in a brewing position, as described in detail below. The boiler/heater 522 and pump 524 may be of the type commonly utilized in
15 the art. As with the shower head 132 of the coffee appliance 100, the shower head 528 is preferably annular in shape and has a plurality of apertures on an underside thereof for distributing heated water to the filter cup 10 in the brewing position within the housing 508. As will be readily appreciated, the water flow path and components for delivering heated water to the filter cup 10 are substantially similar to the flow path and
20 components of the coffee appliance 100.

As shown in FIGS. 71-79, the appliance 500 further includes a grinder 530, powered by a grinder motor. The grinder 530 is disposed within the housing 508 and positioned above the recess in the housing 508 for the brewing cartridge 510. A
25 cavity/inlet extends from the top surface of the housing 508 to the grinder and defines a hopper 532 for receiving at least one drink ingredient, such as a plurality of whole coffee beans 20. An outlet passageway 534 extends from the grinder 530 to the brewing cartridge recess in the housing 508. As shown therein, a shutter 536 is positioned within the outlet passageway 534 adjacent the grinder 530 and is moveable between a closed state, in which the passageway 534 is obstructed by the shutter 536 to prohibit the
30 passage of ground coffee 538 therethrough, and an open state, in which the outlet passageway 534 is not obstructed by the shutter 536 such that ground coffee 538 may flow through the passageway 534 and into the filter cup 10 positioned in the brewing cartridge 510, as discussed below. A shutter motor 540 controls the shutter 536 between

the first state and the second state. The shutter 536 may be a mechanical shutter, although other types of shutters or valves may be utilized to selectively block the flow of coffee grounds 538 through the outlet passageway 534, without departing from the broader aspects of the present invention.

5 In an embodiment of the present invention, the grinder 530 is a flat burr grinder. In another embodiment of the present invention, the grinder 530 may be a conical burr grinder. Importantly, the appliance 500 also includes a piercing mechanism 542 for piercing the foil cover 18 of the filter cup 10 so that the coffee beans 20 in the filter cup 10 may be transferred to the hopper 532. In the preferred embodiment, the piercing
10 mechanism 542 is an annular or semi-annular cylinder or truncated cone formed from metal or other rigid material that extends upwards from the hopper 532 out of the housing 508. As shown in FIG. 71, the piercing mechanism 542 has a sharp upper edge and is complimentary in shape and size to the interior sidewalls 24 of the filter cup 10 such that when the filter cup 10 is turned upside down and placed onto the appliance
15 500, the piercing mechanism 542 punctures the foil cover 18 adjacent the sidewalls and enters the cup body 12 such that the piercing mechanism 542 is closely received by the sidewalls 24 interior of the cup 10. In the preferred embodiment, the piercing mechanism 542 is a thin-walled, conical shaped tube.

The pump 524, boiler 522, grinder motor and shutter motor 540 are each
20 electrically connected to a controller for controlling operation thereof. A control panel (not shown) on the housing 508 is electrically connected to the controller and provides an interface for a user to control operation of the appliance 500, such as the number of cups to be brewed, automatic brewing and timer features, etc.

Operation of the coffee appliance 500 will now be described with reference to
25 FIGS. 71-79. As shown in FIG. 71 and 72, first, a user selects a pre-packaged filter cup 10 containing a plurality of whole coffee beans 20. The filter cup 10 is then turned upside down and urged towards the hopper 532 in the direction of arrow *A*, such that the upper edges of the piercing mechanism 542 pierce through the foil cover 18 of the cup 10 and the cup 10 is received on the complimentary-shaped piercing mechanism
30 542. As the coffee beans 20 are no longer retained inside the cup by the cover 18, gravity causes the coffee beans to exit the cup 10 and the whole coffee beans 20 are received by the hopper 532 of the grinder 530.

As shown in FIG. 73, the empty filter cup 10 is removed from the hopper 532 and piercing mechanism 542. At this point, the cover 18 will have been either removed from the filter cup 10 by the piercing mechanism 542, in which case a user can then dispose of the cover 18, or partially removed and pressed against the inside of the filter cup 10. In any event, the filter cup 10 is now open at the top. The empty filter cup 10 is then placed into the brewing cartridge 510, and the brewing cartridge 510 is inserted into the appliance 500 below the outlet passageway 532 and shower head 528, in the manner described above, as shown in FIG 74. In an embodiment, the appliance 500 may also include a sensor in electrical communication with the controller. The sensor will detect when the brewing cartridge 510 and or empty filter cup 10 is properly received and aligned within the housing. Upon detection of the brewing cartridge 510 and/or filter cup 10, the controller will actuate the shutter motor 540, prompting the grinder shutter 536 to automatically open, thereby opening the passageway 534 from the grinder 530 to the filter cup 10.

Turning now to FIG. 75, once the shutter 536 is controlled to its open state, the grinder 530 (and grinder motor) will automatically switch to an ON position upon signaling from the controller. The grinder 530 will grind the whole coffee beans 20 in the hopper 532 to transform them into coffee grounds 538. The coffee grounds 538 exit the grinder 530, pass through the exit passageway 534, and collect in the filter cup 10. In particular, the coffee grounds 538 collect on top of the protective screen 16 and filter 14 in the filter cup 10. After the whole coffee beans 20 are ground into coffee grounds 538 by the grinder 530 and deposited in the filter cup 10, the shutter motor 540 causes the shutter 536 to automatically close, thereby blocking the outlet passageway 534, as shown in FIG. 76. In an embodiment, the shutter 536 may automatically close after a predetermined amount of time. Importantly, closure of the shutter 536 ensures that none of the coffee grounds 536 can backflow to the grinder 530 during brewing.

As shown in FIG. 77, after closure of the shutter 536, water is pumped from the water reservoir 520 through the boiler 522, which heats the water to a predetermined temperature. The water then continues from the boiler 522, through the supply conduit 526 and to the water outlet/shower head 528. The hot water is then passed through the filter cup 10 and the coffee grounds 528 therein to produce brewed coffee. The brewed coffee exits the filter cup 10 through the apertures 32 in the floor 26 thereof, exits the

brewing cartridge 510 through the aperture 516 in the bottom thereof, and collects in a coffee cup 544 positioned on the drip tray 506.

In an embodiment, the flow rate of hot water from the reservoir 520 to the filter cup 10 is faster than the brewed coffee output rate from the filter cup 10 to the coffee cup 544, which results in low-pressure brewing. In an embodiment, the shutter 536 and an edge of the filter cup 10 include a seal ring, such as a rubber O-ring, to prevent leakage.

Next, an optional post-brewing step includes purging the system to blow out any remaining water in the lines. In the purging step, near or at the end of the brewing step, the pump 524 will stop prior to the heater(s) of the boiler 522 being switched off. This results in the excess water remaining in the boiler 524 being converted to steam. The steam then travels through the supply conduit 526 and forces out the hot water in the brewing subassembly (conduit 526, shower head 528, etc.) and filter cup 10. As will be readily appreciated, this ensures that substantially all of the coffee in the cup 10 exits without substantial dripping. In addition, this also ensures that the cup 10 is dry and does not drip when it is removed for disposal.

As shown in FIGS. 78 and 79, the coffee cup 544 filled with brewed coffee may then be removed from the appliance 500. The brewing cartridge 510 may then be disengaged from the housing 508. Lastly, the filter cup 10 containing used coffee grounds 538 may be discarded in a trash receptacle 546. Optionally, the shower head 527 and components adjacent the shower head may be cleaned between uses.

Importantly, the filter cup 10 is utilized to both hold an optimal volume of whole coffee beans 20 prior to transfer into the hopper 532 for grinding by the grinder 530, as well as to collect the ground coffee 538 and to function as a filter during brewing, as discussed above. While the preferred embodiment contemplates the use of the coffee appliance 500 with a filter cup 10 containing whole coffee beans 20, the present invention is not intended to be limited in this regard. In particular, the coffee appliance 500 may be utilized with a filter cup 10 or other similar cup containing drink ingredients of any type, and preferably drink ingredients that require grinding, chopping, cutting, etc.

Although this invention has been shown and described with respect to the detailed embodiments thereof, it will be understood by those of skill in the art that various changes may be made and equivalents may be substituted for elements thereof

without departing from the scope of the invention. In addition, modifications may be made to adapt a particular situation or material to the teachings of the invention without departing from the essential scope thereof. Therefore, it is intended that the invention not be limited to the particular embodiments disclosed in the above detailed
5 description, but that the invention will include all embodiments falling within the scope of this disclosure.

WHAT IS CLAIMED IS:

1. A beverage assembly, comprising:
 - a housing, said housing including a liquid reservoir;
 - 5 an inlet portion formed in said housing;
 - a beverage container configured to be removably accommodated within said inlet portion, said beverage container having a fracturable seal and containing a beverage ingredient of a first size;
 - a grinding mechanism positioned within said housing and in fluid
 - 10 communication with said inlet portion;
 - a piercing assembly positioned within said housing, wherein said piercing assembly selectively pierces said fracturable seal thereby causing said beverage ingredient to enter said grinding mechanism;
 - said grinding mechanism selectively transforming said beverage ingredient from
 - 15 said first size to a second size, said second size being smaller than said first size;
 - a brewing area disposed beneath said grinding assembly, said brewing area configured to removably accommodate said beverage container after said beverage container has been pierced by said piercing assembly;
 - wherein a liquid from said liquid reservoir is directed to said beverage container
 - 20 after said beverage ingredient of said second size has passed from said grinding mechanism into said beverage container such that said liquid exits an outlet of said beverage container after passing through said beverage ingredient of said second size.
2. The beverage assembly of claim 1, further comprising:
 - 25 a brewing tray removably accommodated within said brewing area, said brewing tray being configured to removably accommodate said beverage container.
3. The beverage assembly of claim 1, wherein:
 - said grinding mechanism is a burr grinder.
- 30 4. The beverage assembly of claim 1, wherein:
 - said burr grinder is one of a flat burr grinder and a conical burr grinder.

5. The beverage assembly of claim 1, further comprising:
a passageway between said outlet of said grinding mechanism and said brewing area; and
a shutter positioned in said passageway, said shutter being movable between a first position in which said shutter obstructs said passageway, and a second position in which said shutter does not substantially obstruct said passageway.
6. The beverage assembly of claim 5, further comprising:
a motor for controlling said shutter between said first position and said second position.
7. The beverage assembly of claim 1, wherein:
said beverage ingredient is a plurality of whole coffee beans.
8. The beverage assembly of claim 1, further comprising:
a pump in fluid communication with said liquid reservoir;
a boiler in fluid communication with said pump;
a hot water supply line in fluid communication with said boiler; and
a hot water outlet in fluid communication with said hot water supply line and positioned above said brewing area for directing a flow of heated liquid to said brewing area.
9. The beverage assembly of claim 1, wherein:
said brewing tray includes a generally conical shaped body, a flange extending outwardly from said body at a top thereof, and an aperture formed in a bottom of said body for permitting a flow of brewed coffee therethrough.

10. A coffee appliance, comprising:
a housing, said housing including a liquid reservoir;
an inlet portion formed in said housing;
a beverage container configured to be removably accommodated within said
5 inlet portion, said beverage container having a fracturable seal and containing a
plurality of whole coffee beans;
a grinding mechanism positioned within said housing and in fluid
communication with said inlet portion;
a piercing assembly positioned within said housing, wherein said piercing
10 assembly selectively pierces said fracturable seal thereby causing said whole coffee
beans to enter said grinding mechanism;
said grinding mechanism selectively transforming said whole coffee beans into
coffee grounds;
a brewing area disposed beneath said grinding assembly, said brewing area
15 configured to removably accommodate said beverage container after said beverage
container has been pierced by said piercing assembly;
wherein a liquid from said liquid reservoir is directed to said beverage container
after said coffee grounds have passed from said grinding mechanism into said beverage
container such that said liquid exits an outlet of said beverage container after passing
20 through said coffee grounds.
11. The coffee appliance of claim 10, wherein:
said grinding mechanism is a burr coffee grinder.
- 25 12. The coffee appliance of claim 11, further comprising:
a passageway configured to direct said coffee grounds from said burr coffee
grinder to said brewing area; and
a shutter positioned in said passageway, said shutter being movable between a
first position in which said shutter obstructs said passageway, and a second position in
30 which said shutter does not substantially obstruct said passageway.

13. The coffee appliance of claim 12, further comprising:
a shower head positioned above said brewing container and configured to distribute said liquid to said beverage container.
- 5 14. The coffee appliance of claim 12, further comprising:
a motor for controlling said shutter between said first position and said second position.
- 10 15. The coffee appliance of claim 13, further comprising:
a pump in fluid communication with said reservoir;
a boiler in fluid communication with said pump; and
a liquid supply line in fluid communication with said boiler and said shower head.
- 15 16. A method of brewing coffee, said method comprising the steps of:
loading a plurality of whole coffee beans from a beverage container into a hopper of a coffee appliance;
positioning said beverage container in a brewing area of said appliance;
grinding said whole coffee beans within said appliance to produce coffee
20 grounds;
transferring said coffee grounds to said beverage container in said brewing area;
and
infusing hot water into said coffee grounds to produce brewed coffee.
- 25 17. The method of brewing coffee according to claim 16, wherein:
said step of loading a plurality of whole coffee beans into said hopper includes piercing a fracturable cover of said beverage container and transferring said coffee beans from said beverage container to said hopper.
- 30 18. The method of brewing coffee according to claim 16, further comprising the step of:
controlling a shutter to a closed position to block a passageway from a grinding mechanism to said brewing area to prevent backflow during said infusing step.

19. The method of brewing coffee according to claim 16, further comprising:
controlling a shutter to an open position to enable said transfer of said coffee grounds to said brewing area.
- 5 20. The method of brewing coffee according to claim 16, further comprising the step of:
directing a flow of steam to said brewing area to purge said beverage container of liquid.

AMENDED CLAIMS

received by the International Bureau on 11 January 2013 (11.01.2013)

1. **A beverage assembly, comprising:**
 - a housing, said housing including a liquid reservoir;**
 - an inlet portion formed in said housing;**
 - a beverage container configured to be removably accommodated within said inlet portion, said beverage container having a fracturable seal and containing a beverage ingredient of a first size;**
 - a grinding mechanism positioned within said housing and in fluid communication with said inlet portion;**
 - a piercing assembly positioned within said housing, wherein said piercing assembly selectively pierces said fracturable seal thereby causing said beverage ingredient to enter said grinding mechanism;**
 - said grinding mechanism selectively transforming said beverage ingredient from said first size to a second size, said second size being smaller than said first size;**
 - a brewing area disposed beneath said grinding assembly, said brewing area configured to removably accommodate said beverage container after said beverage container has been pierced by said piercing assembly;**
 - a passageway between an outlet of said grinding mechanism and said brewing area; and**
 - a shutter positioned in said passageway, said shutter being movable between a first position in which said shutter obstructs said passageway, and a second position in which said shutter does not substantially obstruct said passageway;**
 - wherein a liquid from said liquid reservoir is directed to said beverage container after said beverage ingredient of said second size has passed from said grinding mechanism into said beverage container through said passageway such that said liquid exits an outlet of said beverage container after passing through said beverage ingredient of said second size.**

2. **The beverage assembly of claim 1, further comprising:**
 - a brewing tray removably accommodated within said brewing area, said brewing tray being configured to removably accommodate said beverage container.**

3. The beverage assembly of claim 1, wherein:
said grinding mechanism is a burr grinder.
4. The beverage assembly of claim 1, wherein:
said burr grinder is one of a flat burr grinder and a conical burr grinder.
5. (Canceled).
6. The beverage assembly of claim 1, further comprising:
a motor for controlling said shutter between said first position and said second position.
7. The beverage assembly of claim 1, wherein:
said beverage ingredient is a plurality of whole coffee beans.
8. The beverage assembly of claim 1, further comprising:
a pump in fluid communication with said liquid reservoir;
a boiler in fluid communication with said pump;
a hot water supply line in fluid communication with said boiler; and
a hot water outlet in fluid communication with said hot water supply line and
positioned above said brewing area for directing a flow of heated liquid to said brewing area.
9. The beverage assembly of claim 1, wherein:
said brewing tray includes a generally conical shaped body, a flange extending outwardly from said body at a top thereof, and an aperture formed in a bottom of said body for permitting a flow of brewed coffee therethrough.

10. A coffee appliance, comprising:
a housing, said housing including a liquid reservoir;
an inlet portion formed in said housing;
a beverage container configured to be removably accommodated within said inlet portion, said beverage container having a fracturable seal and containing a plurality of whole coffee beans;
a grinding mechanism positioned within said housing and in fluid communication with said inlet portion;
a piercing assembly positioned within said housing, wherein said piercing assembly selectively pierces said fracturable seal thereby causing said whole coffee beans to enter said grinding mechanism;
said grinding mechanism selectively transforming said whole coffee beans into coffee grounds;
a brewing area disposed beneath said grinding assembly, said brewing area configured to removably accommodate said beverage container after said beverage container has been pierced by said piercing assembly;
wherein a liquid from said liquid reservoir is directed to said beverage container after said coffee grounds have passed from said grinding mechanism into said beverage container such that said liquid exits an outlet of said beverage container after passing through said coffee grounds.
11. The coffee appliance of claim 10, wherein:
said grinding mechanism is a burr coffee grinder.
12. The coffee appliance of claim 11, further comprising:
a passageway configured to direct said coffee grounds from said burr coffee grinder to said brewing area; and
a shutter positioned in said passageway, said shutter being movable between a first position in which said shutter obstructs said passageway, and a second position in which said shutter does not substantially obstruct said passageway.

13. The coffee appliance of claim 12, further comprising:
a shower head positioned above said brewing container and configured to distribute said liquid to said beverage container.
14. The coffee appliance of claim 12, further comprising:
a motor for controlling said shutter between said first position and said second position.
15. The coffee appliance of claim 13, further comprising:
a pump in fluid communication with said reservoir;
a boiler in fluid communication with said pump; and
a liquid supply line in fluid communication with said boiler and said shower head.
16. A method of brewing coffee, said method comprising the steps of:
loading a plurality of whole coffee beans from a beverage container into a hopper of a coffee appliance including piercing a fracturable cover of said beverage container and transferring said coffee beans from said beverage container to said hopper;
positioning said beverage container in a brewing area of said appliance;
grinding said whole coffee beans within said appliance to produce coffee grounds;
transferring said coffee grounds to said beverage container in said brewing area;
and
infusing hot water into said coffee grounds to produce brewed coffee.
17. (Canceled).
18. The method of brewing coffee according to claim 16, further comprising the step of:
controlling a shutter to a closed position to block a passageway from a grinding mechanism to said brewing area to prevent backflow during said infusing step.

19. The method of brewing coffee according to claim 16, further comprising:
controlling a shutter to an open position to enable said transfer of said coffee grounds to said brewing area.

20. The method of brewing coffee according to claim 16, further comprising the step of:
directing a flow of steam to said brewing area to purge said beverage container of liquid.

STATEMENT UNDER ARTICLE 19 (1)

The International Searching Authority has rejected Claims 1-4, 7-11, 16, 18 and 19 as lacking an inventive step under PCT Article 33(3) as being obvious. In particular, claims 1, 2, 7, 8, 9 and 10 have been rejected as being obvious over Lanfrey and Schnabel. Claim 16 has been rejected as being obvious over Roseberry and Cai.

Claims 1, 6 and 16 have been amended. Independent claims 1 and 10 are directed to a beverage assembly and a coffee appliance, respectively that is configured to accept whole coffee beans from a prepackaged cup, grind the beans into coffee grounds, and direct the coffee grounds back into the prepackaged cup in a brewing area of the assembly/appliance, where hot water is then poured over the grounds to produce a brewed beverage. Similarly, independent claim 16 is directed to a method for brewing coffee including loading coffee beans into a hopper from a beverage container, positioning the beverage container in a brewing area, grinding the beans to produce grounds, transferring the grounds to the beverage container and infusing water into the grounds.

Lanfrey is directed to a device for grinding coffee beans directly inside the container carrying a filter. Schnabel is directed to a disposable, whole bean, pre-packaged coffee filter cup.

It is not seen that either Lanfrey nor Schnabel, or any of the other references cited, disclose a passageway between an outlet of the grinding mechanism and the brewing area or the assembly and a shutter positioned in the passageway, as recited in independent claim 1. As such, claim 1, and claims 2-4 and 6-9, which depend therefrom, are urged allowable.

Moreover, it is not seen that Roseberry nor Cai, or any of the other cited references, disclose a method of brewing coffee that includes the step of piercing a fracturable cover of a beverage container and transferring coffee beans from the beverage container to a hopper, as recited in independent claim 16. As such, claim 16, and claims 18-20 which depend respectively therefrom, are urged allowable.

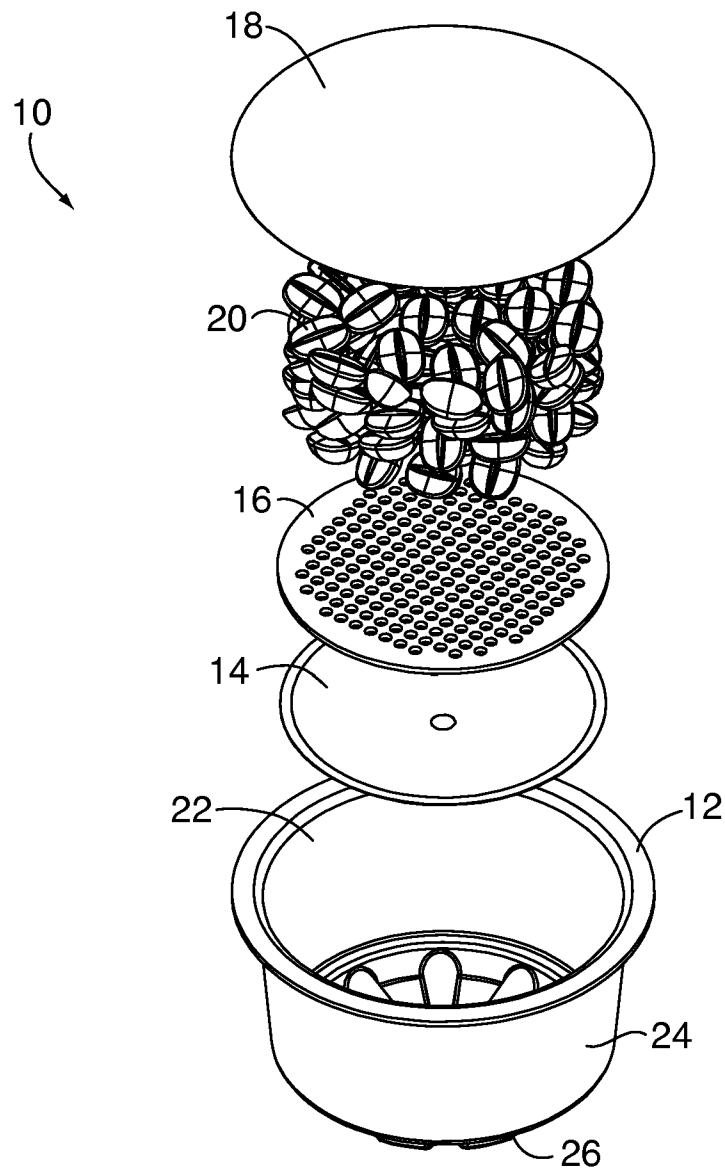

FIG. 1

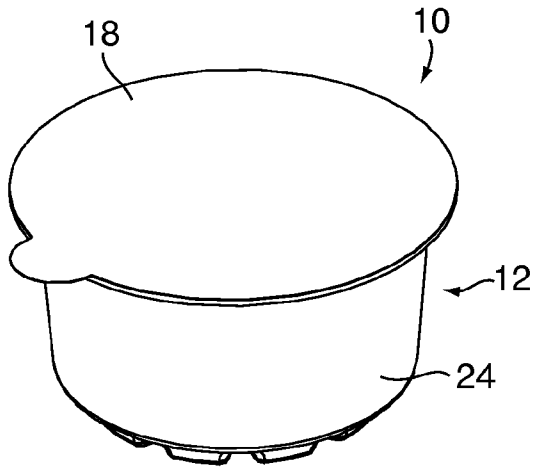

FIG. 2

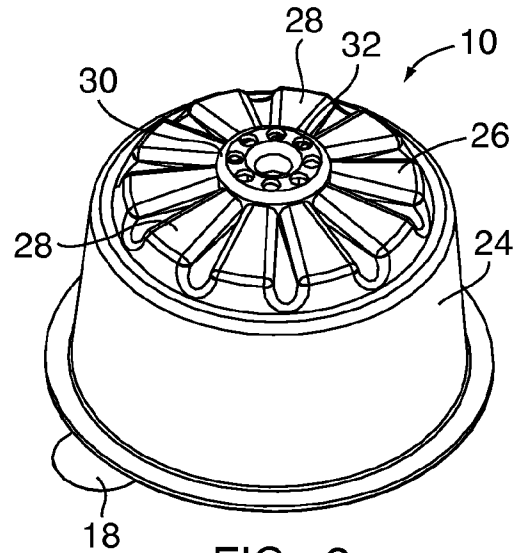

FIG. 3

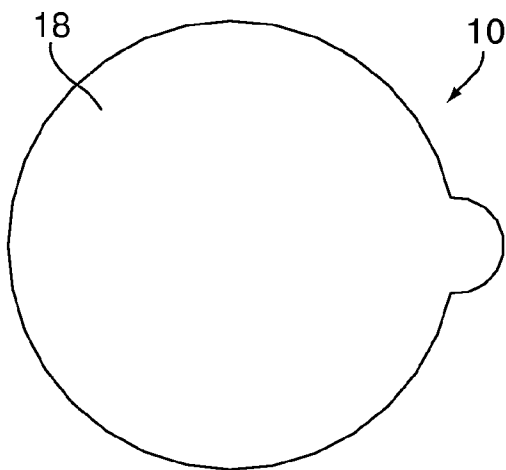

FIG. 4

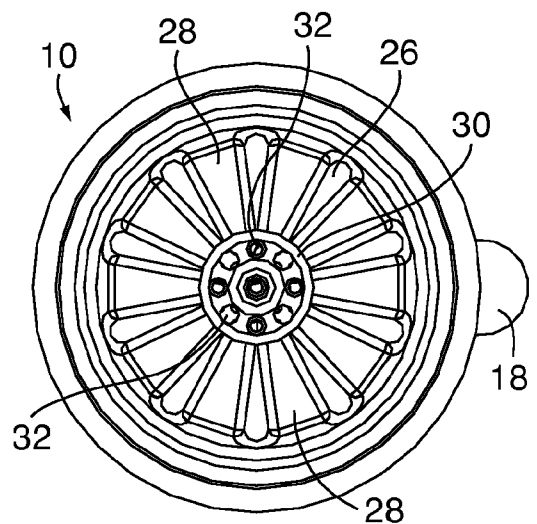

FIG. 5

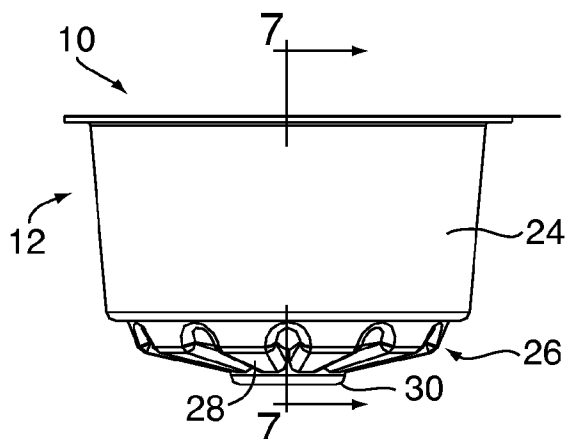

FIG. 6

3/41

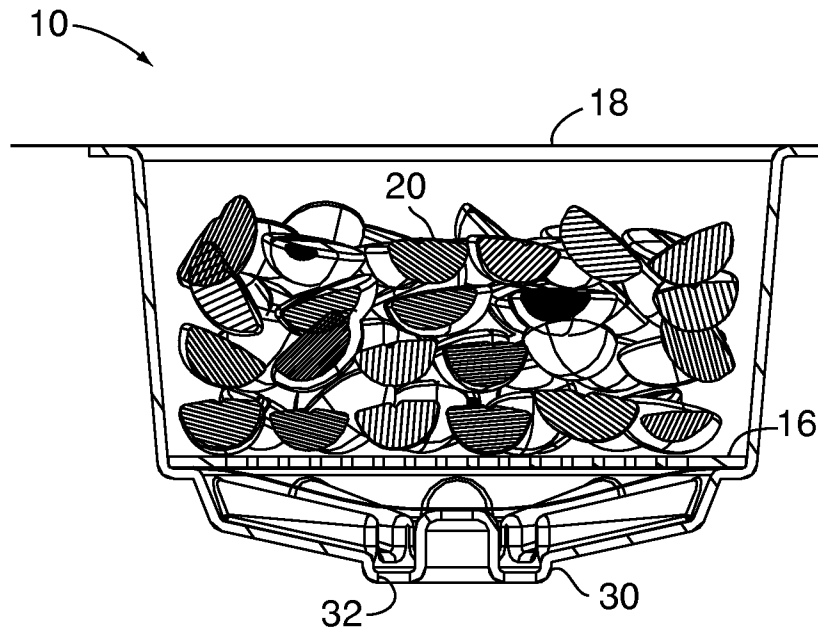

FIG. 7

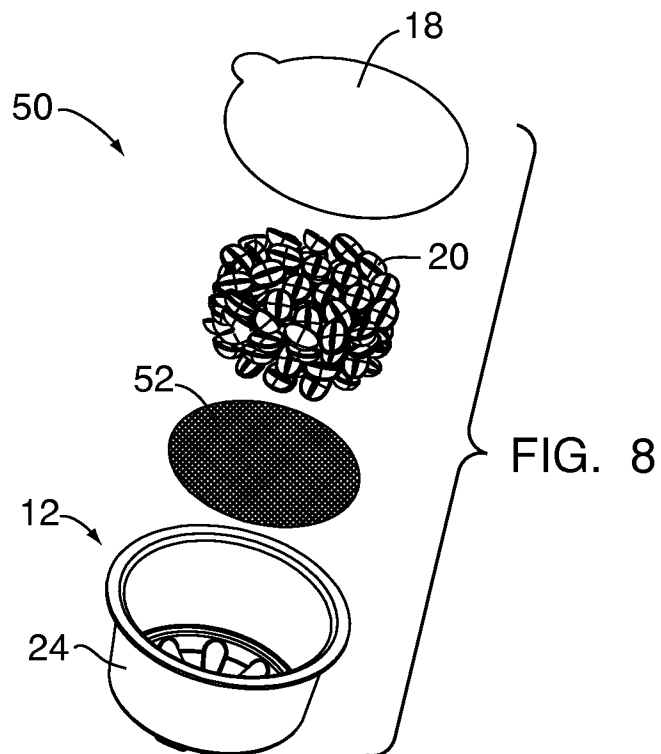

FIG. 8

4/41

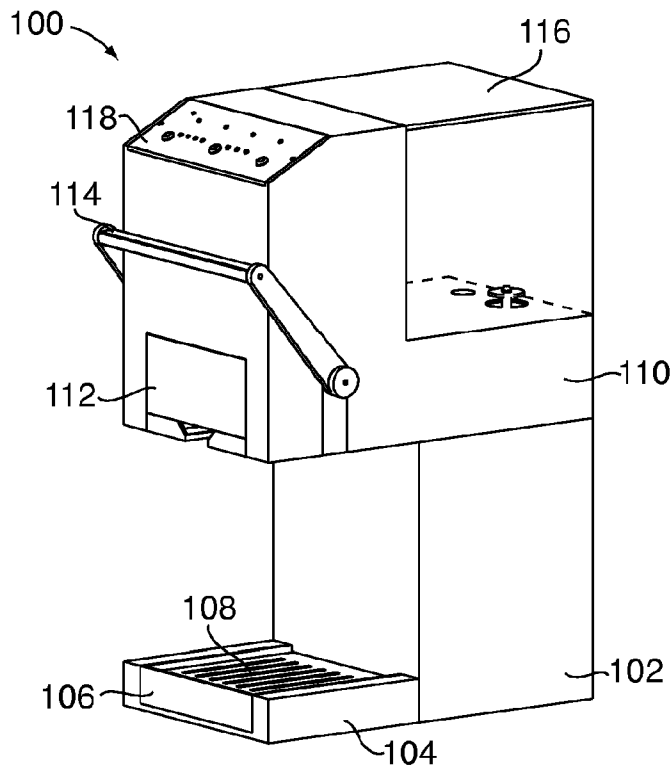

FIG. 9

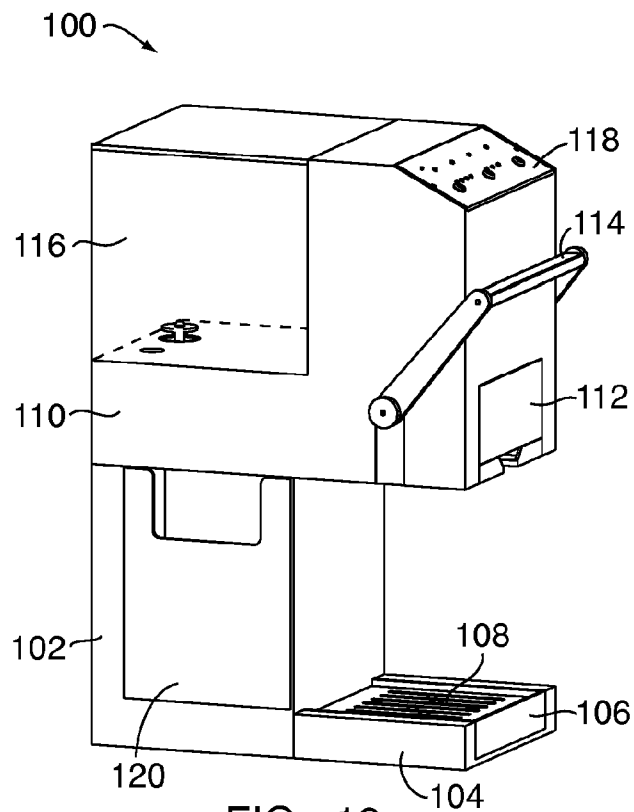
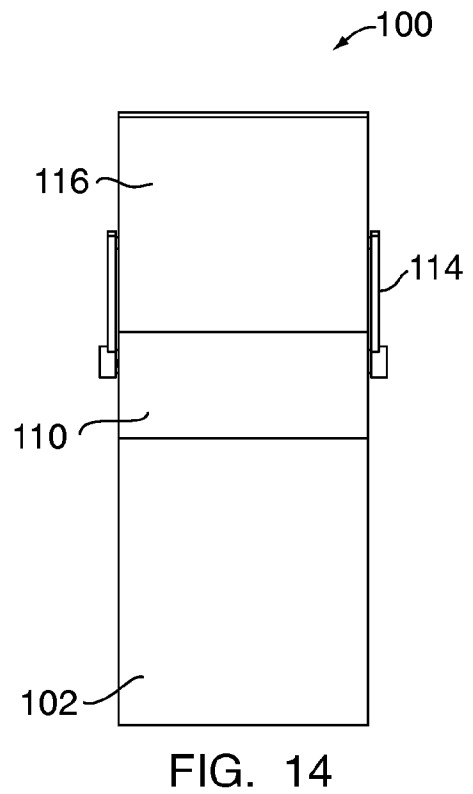
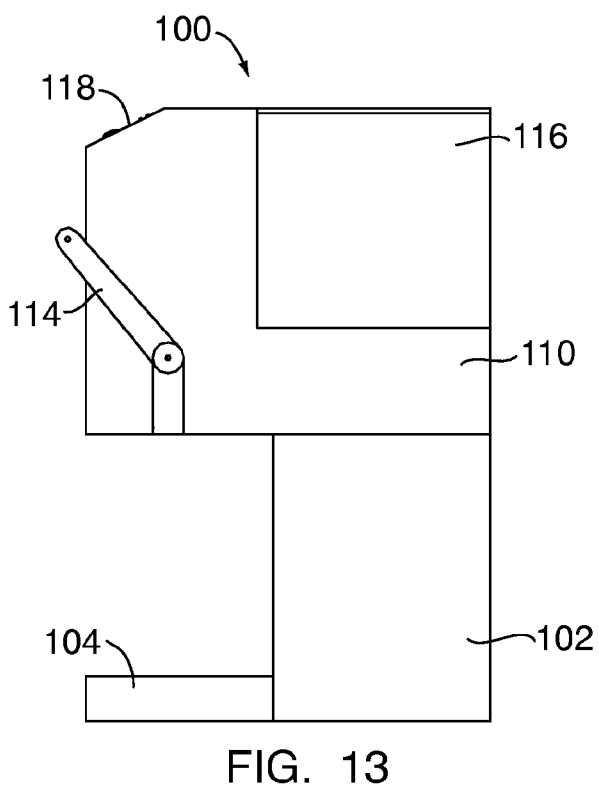
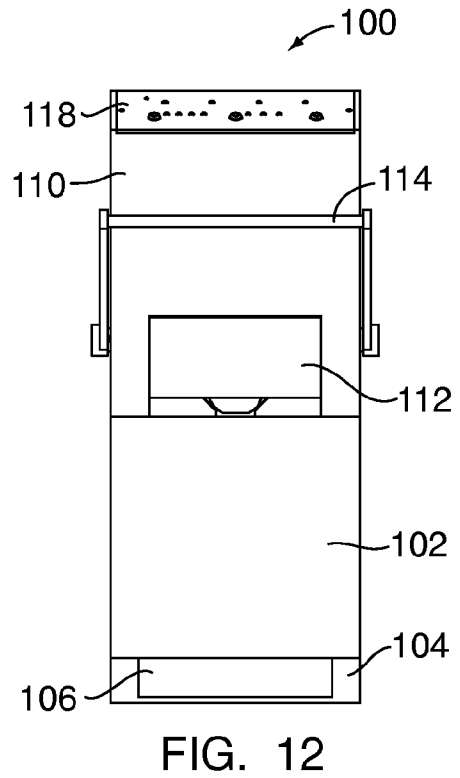
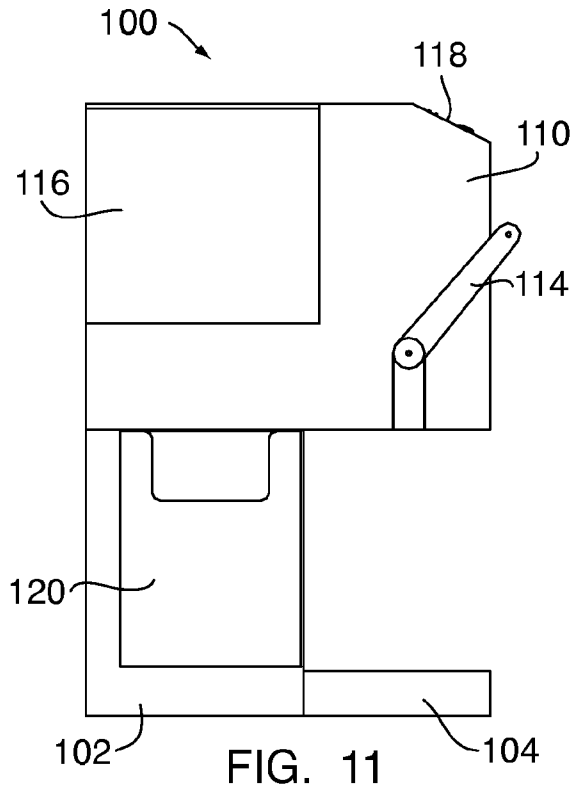

FIG. 10



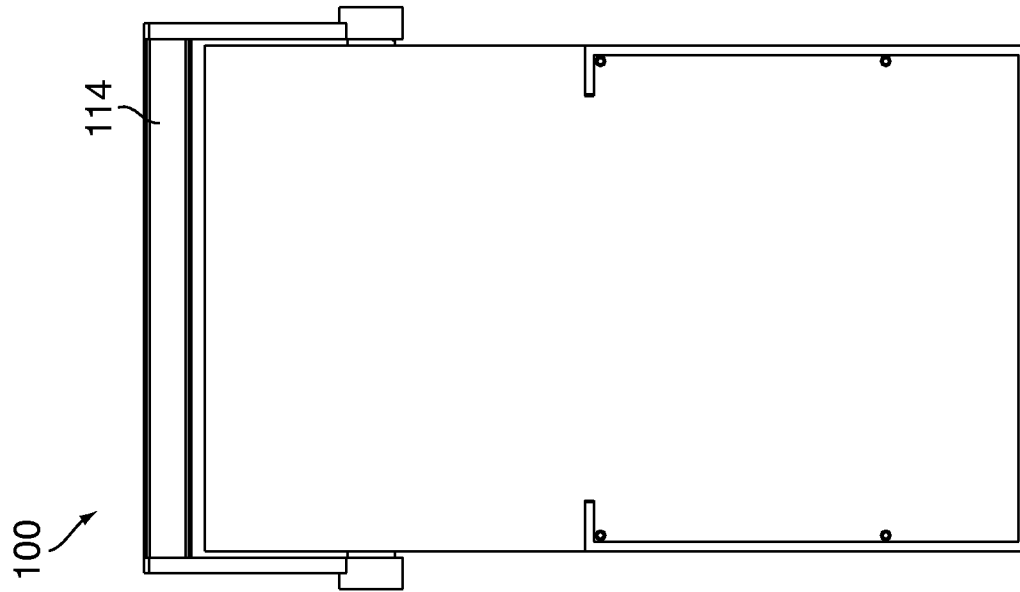

FIG. 16

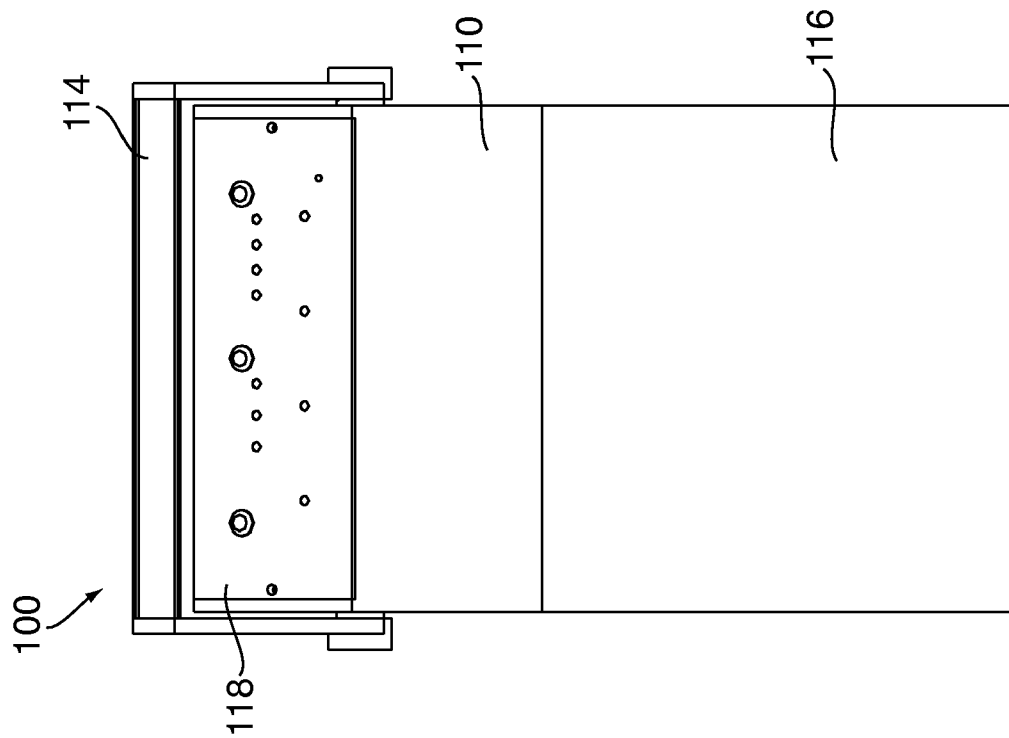

FIG. 15

7/41

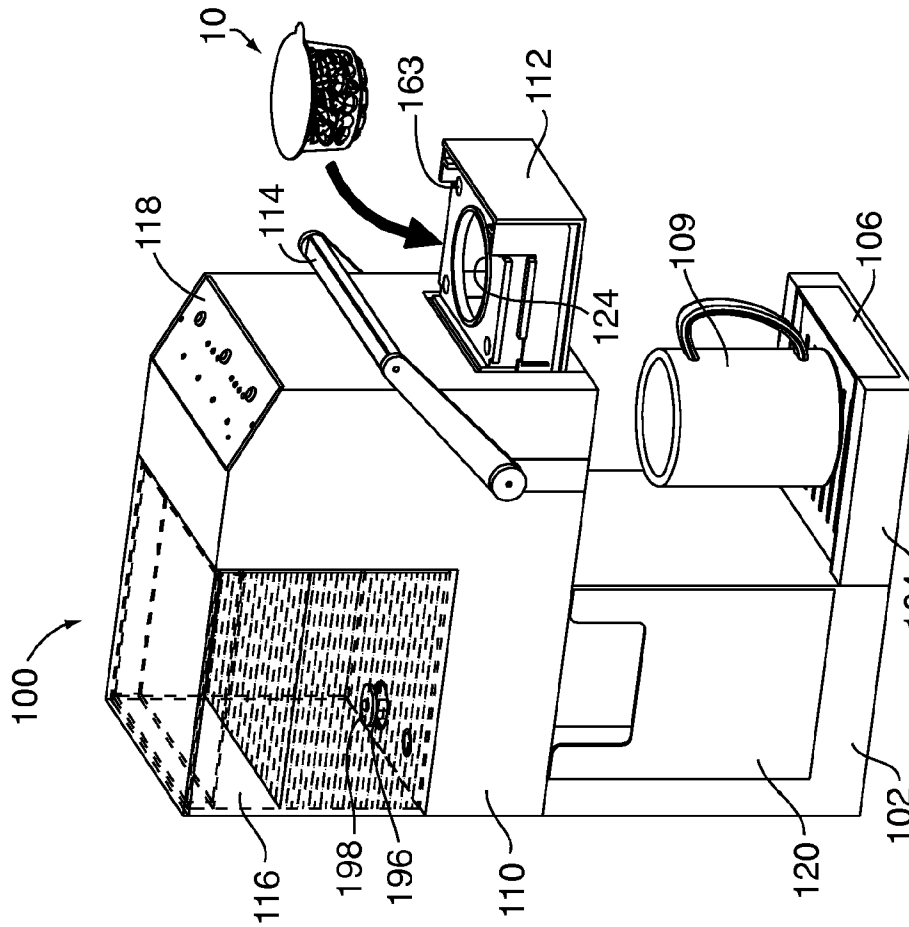

FIG. 18

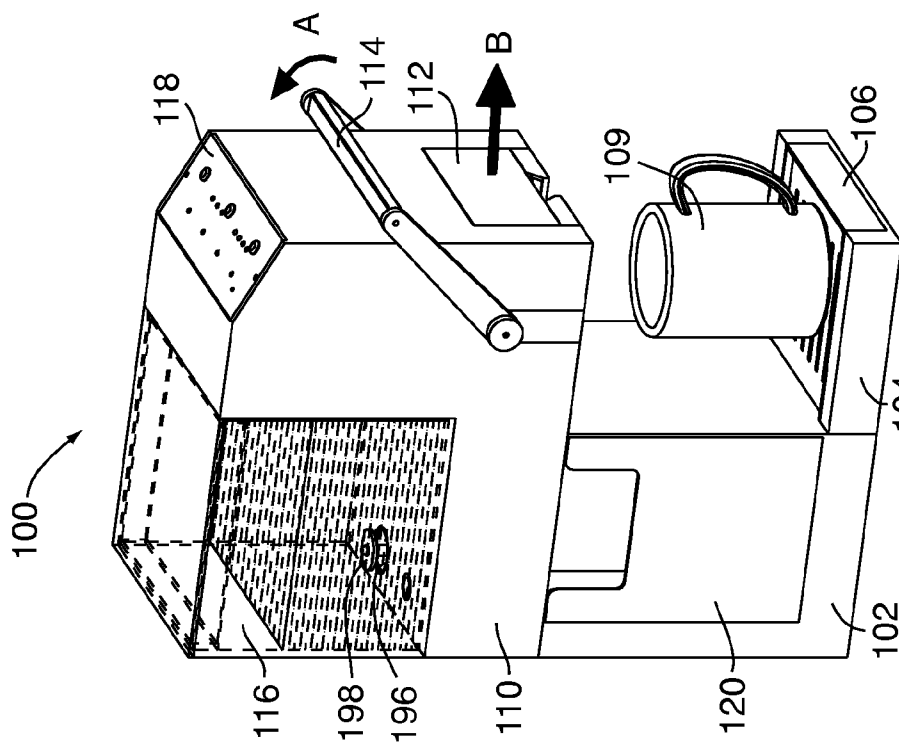
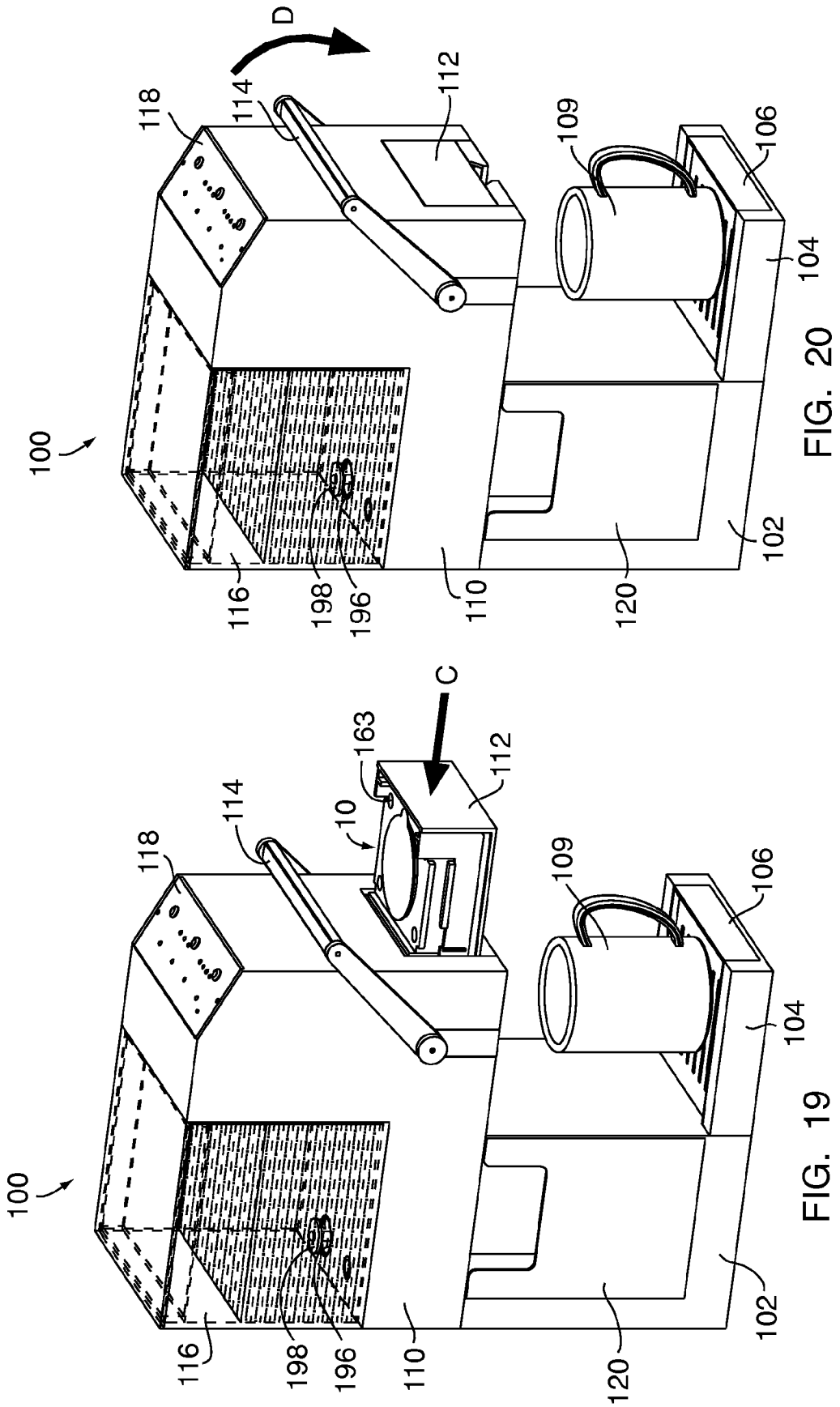

FIG. 17

8/41



9/41

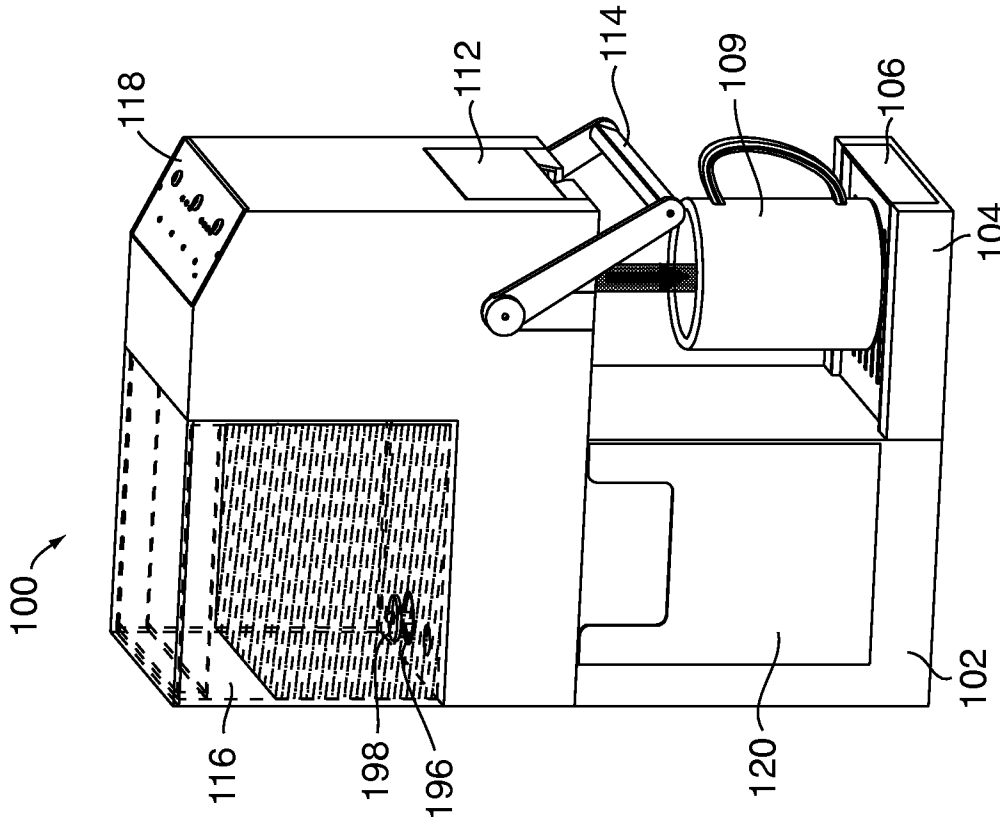

FIG. 22

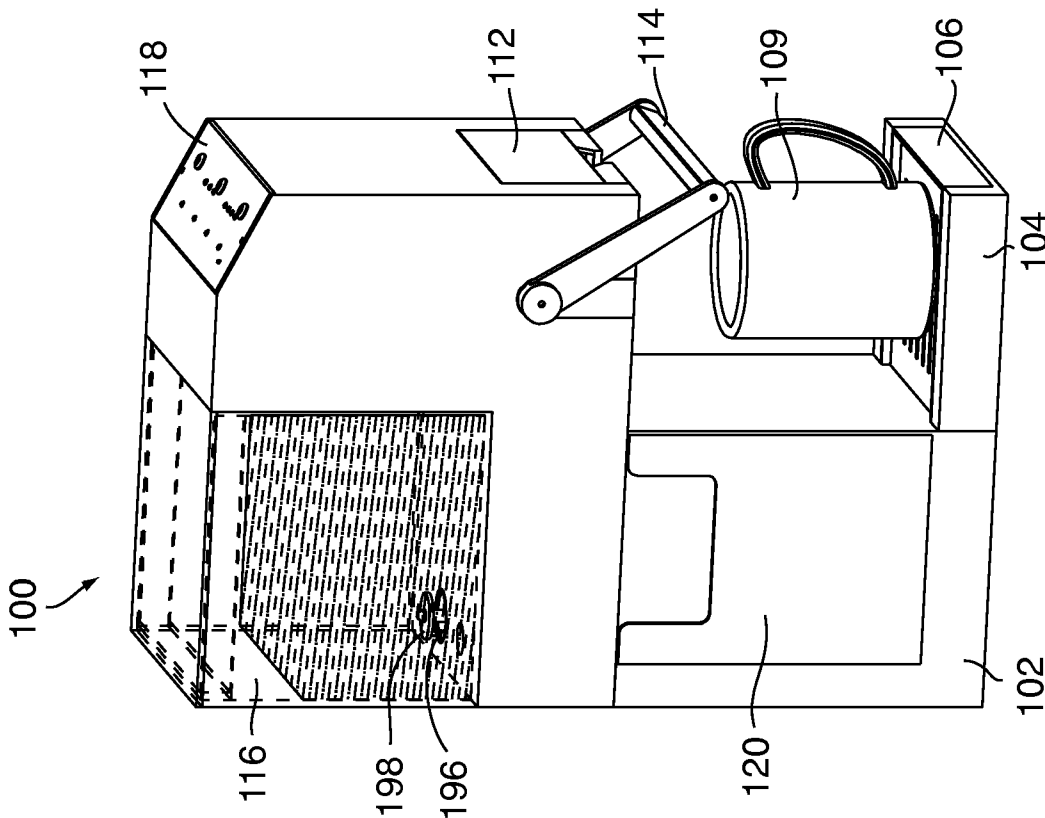
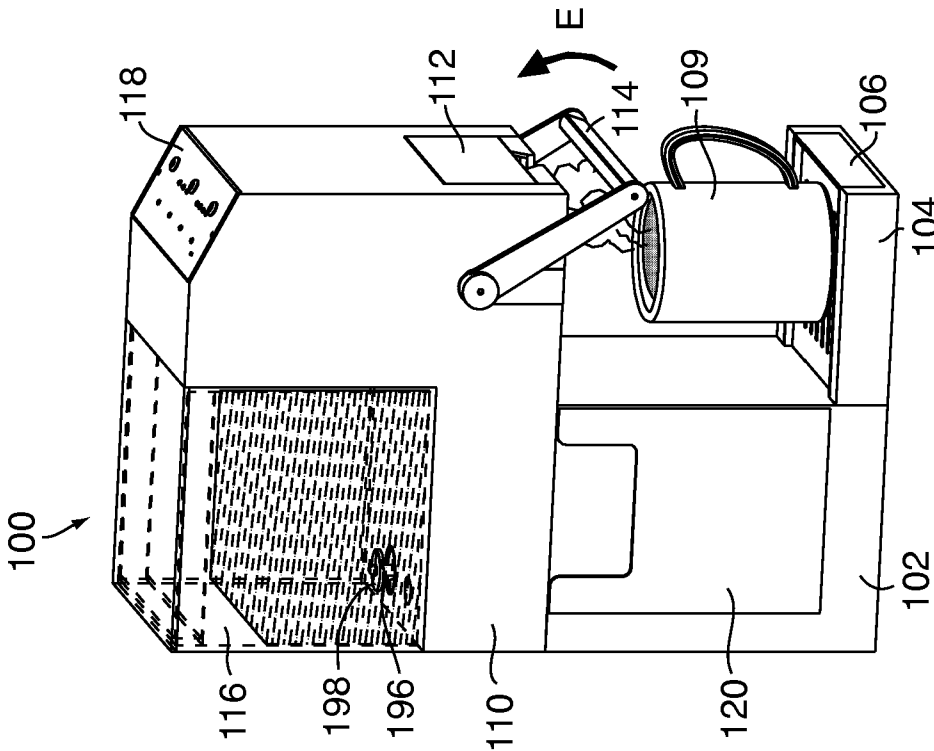
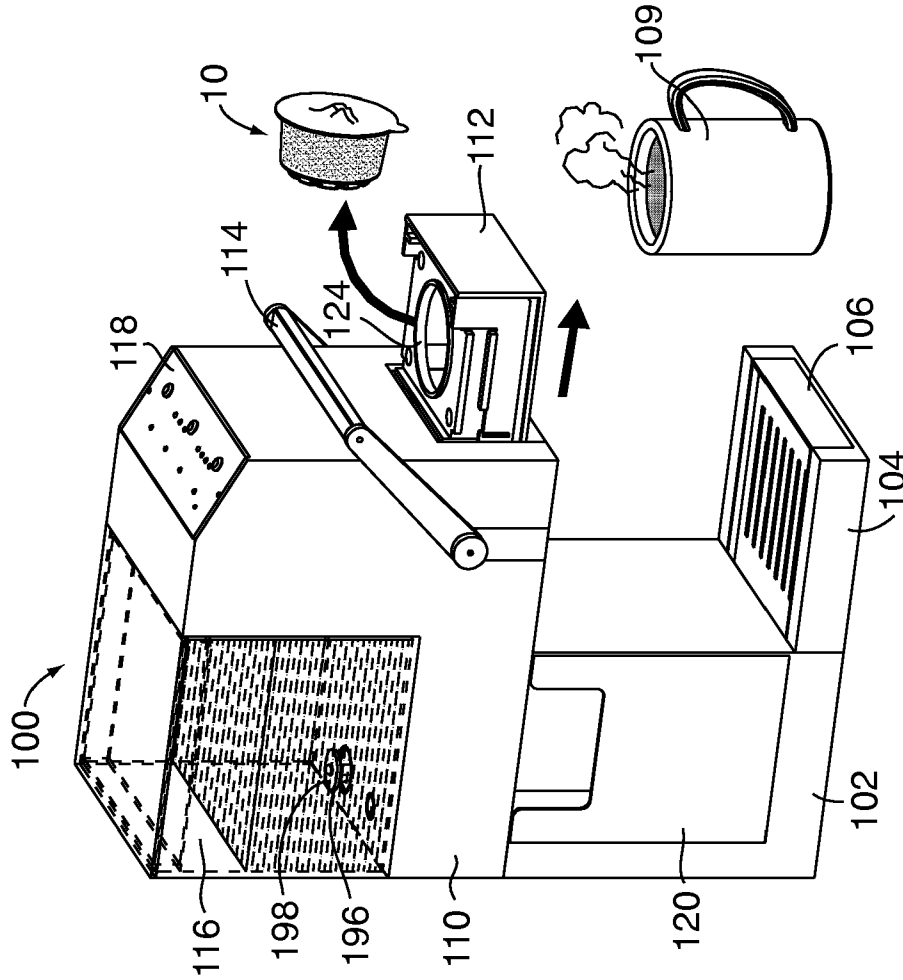

FIG. 21

10/41



11/41

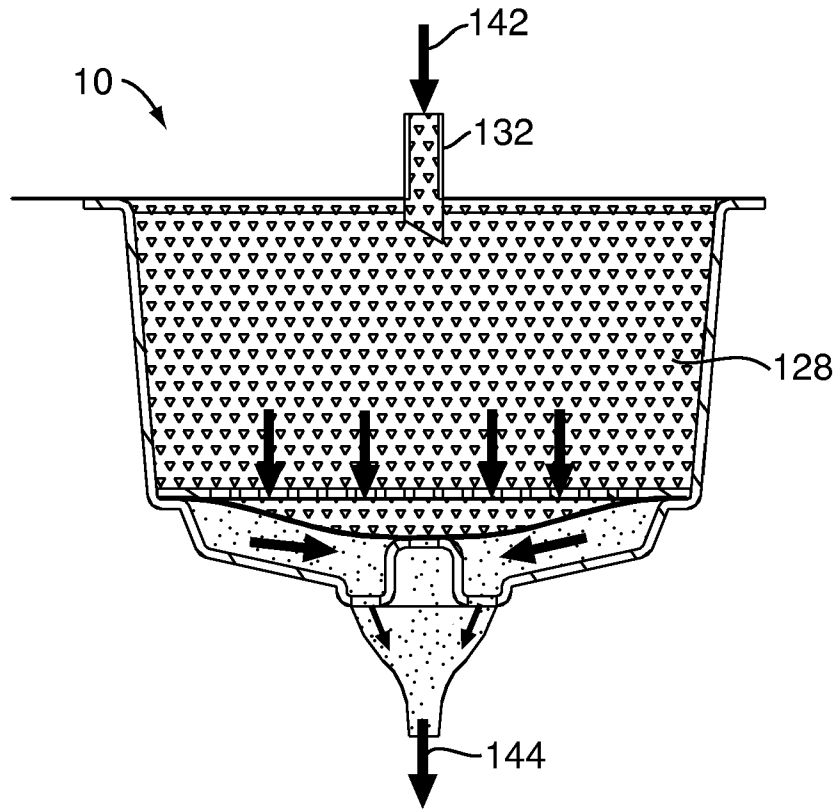

FIG. 25A

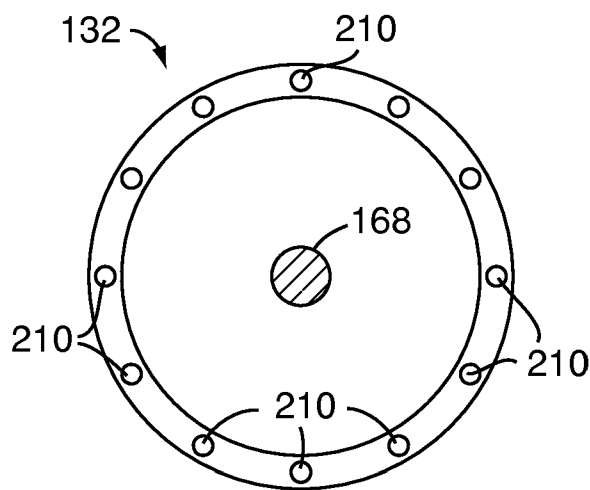

FIG. 25B

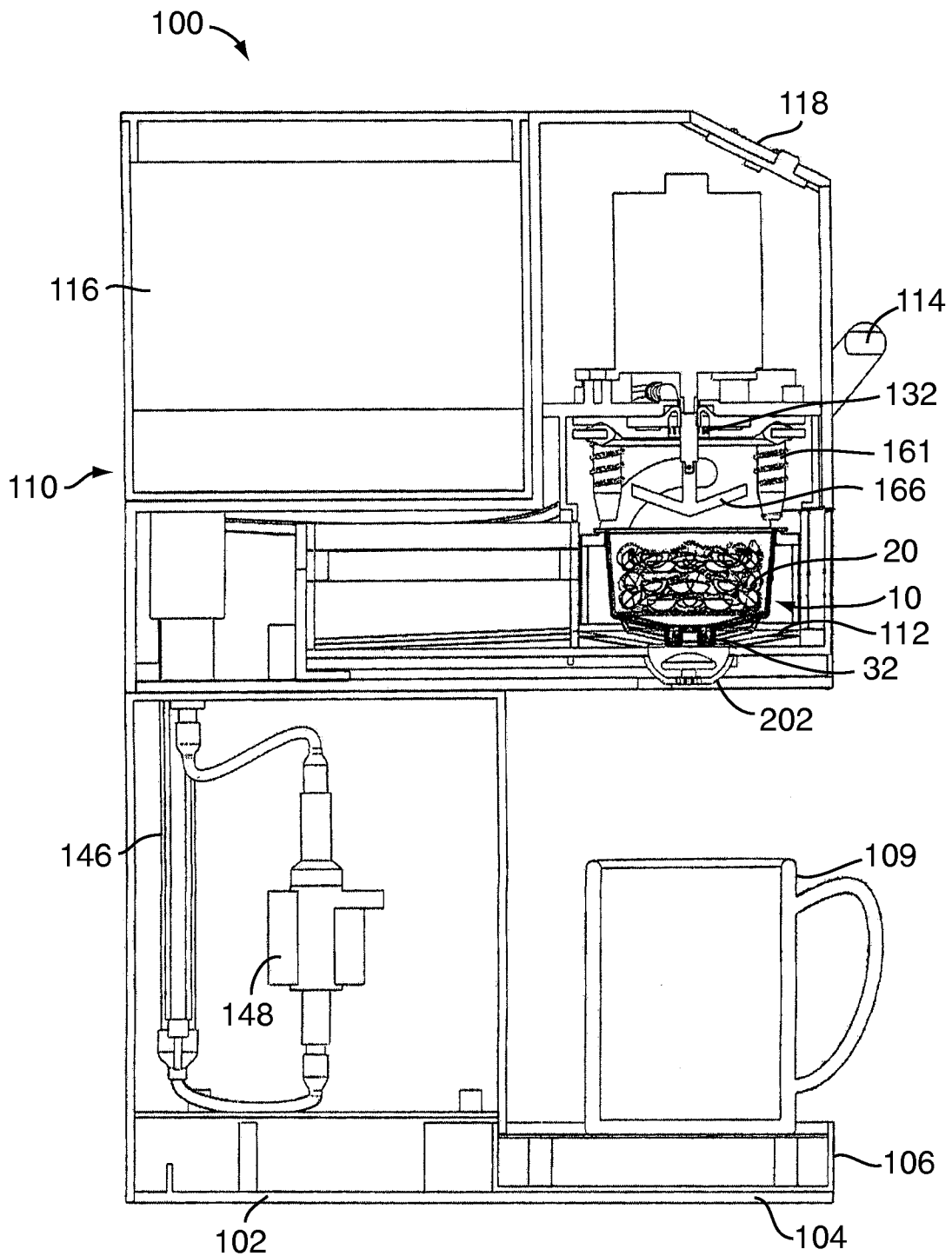

FIG. 26

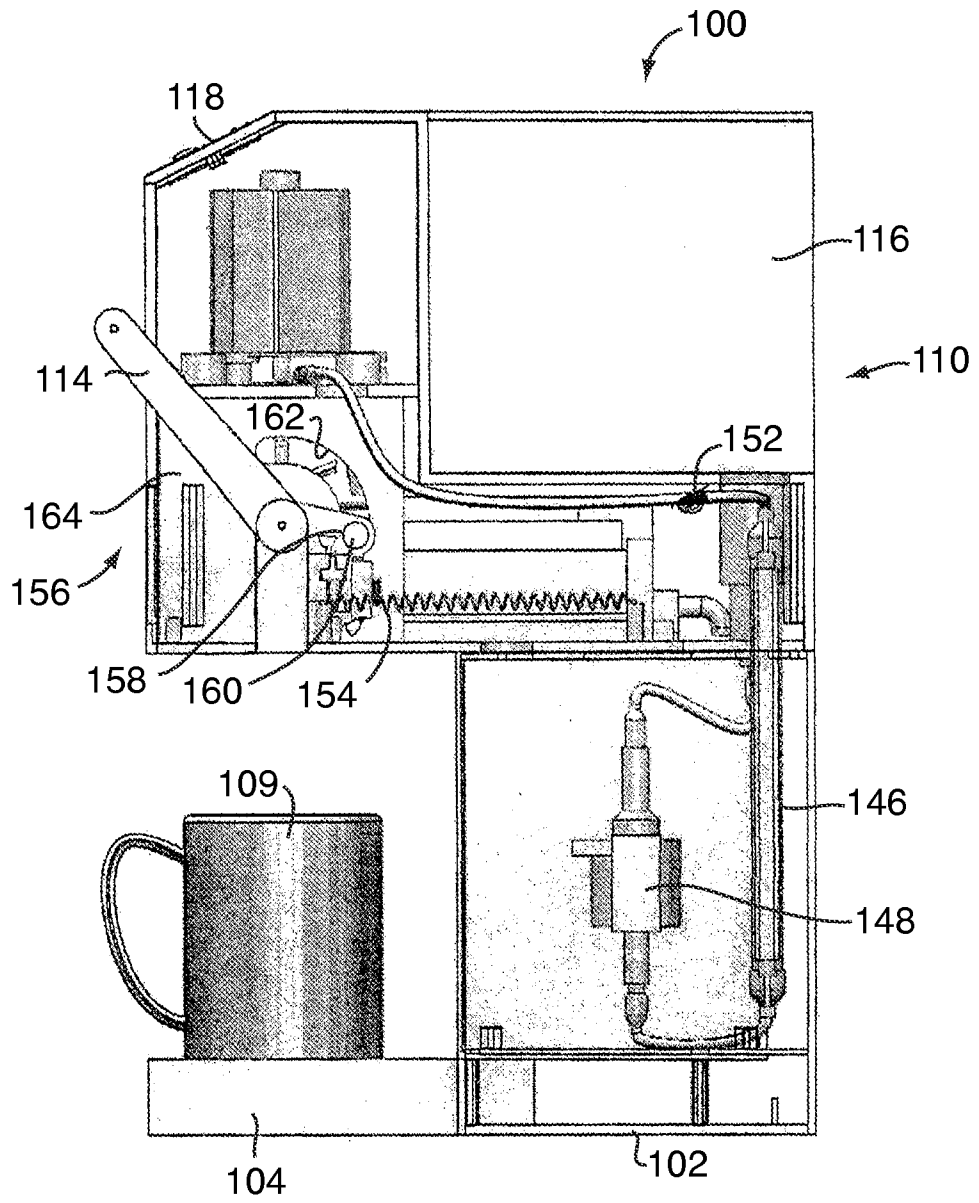

FIG. 27

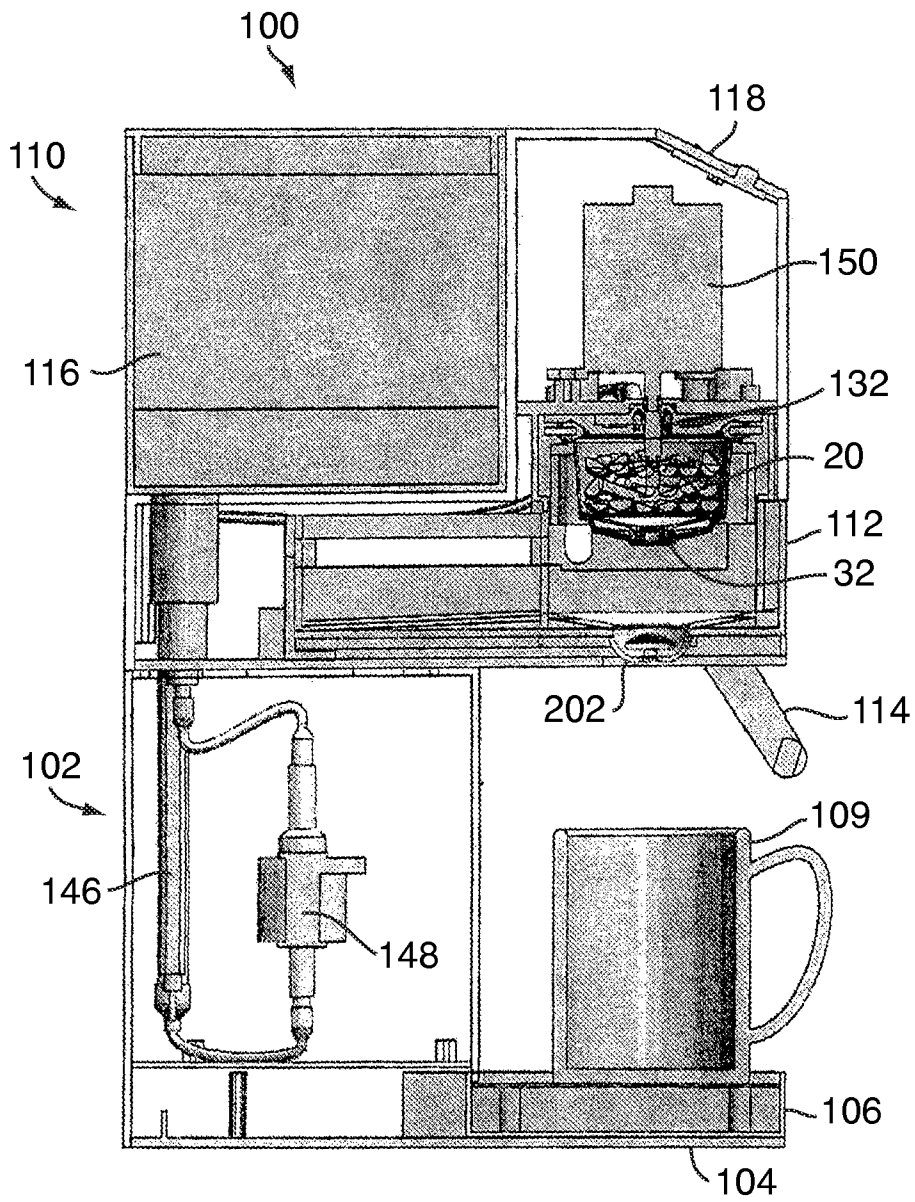
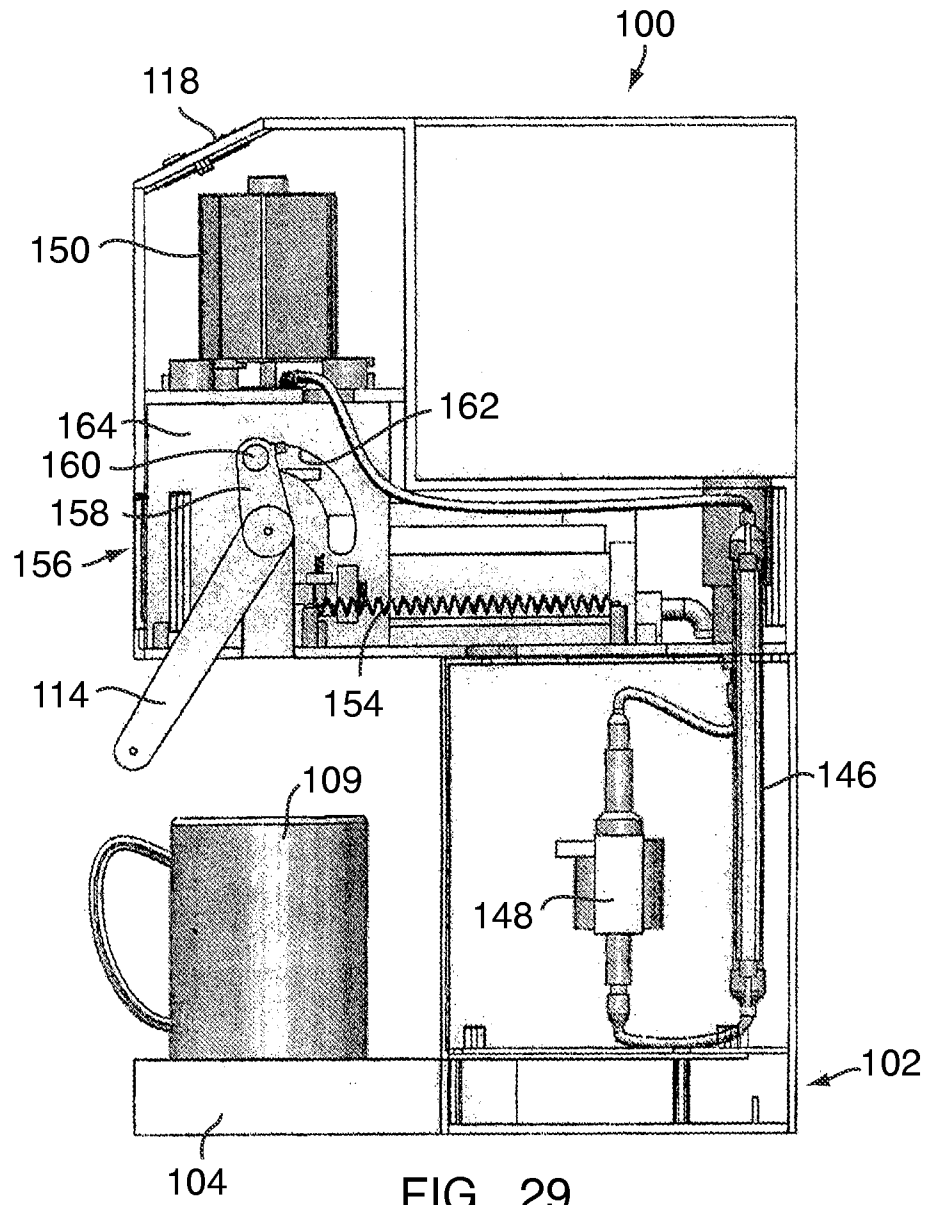

FIG. 28

15/41



16/41

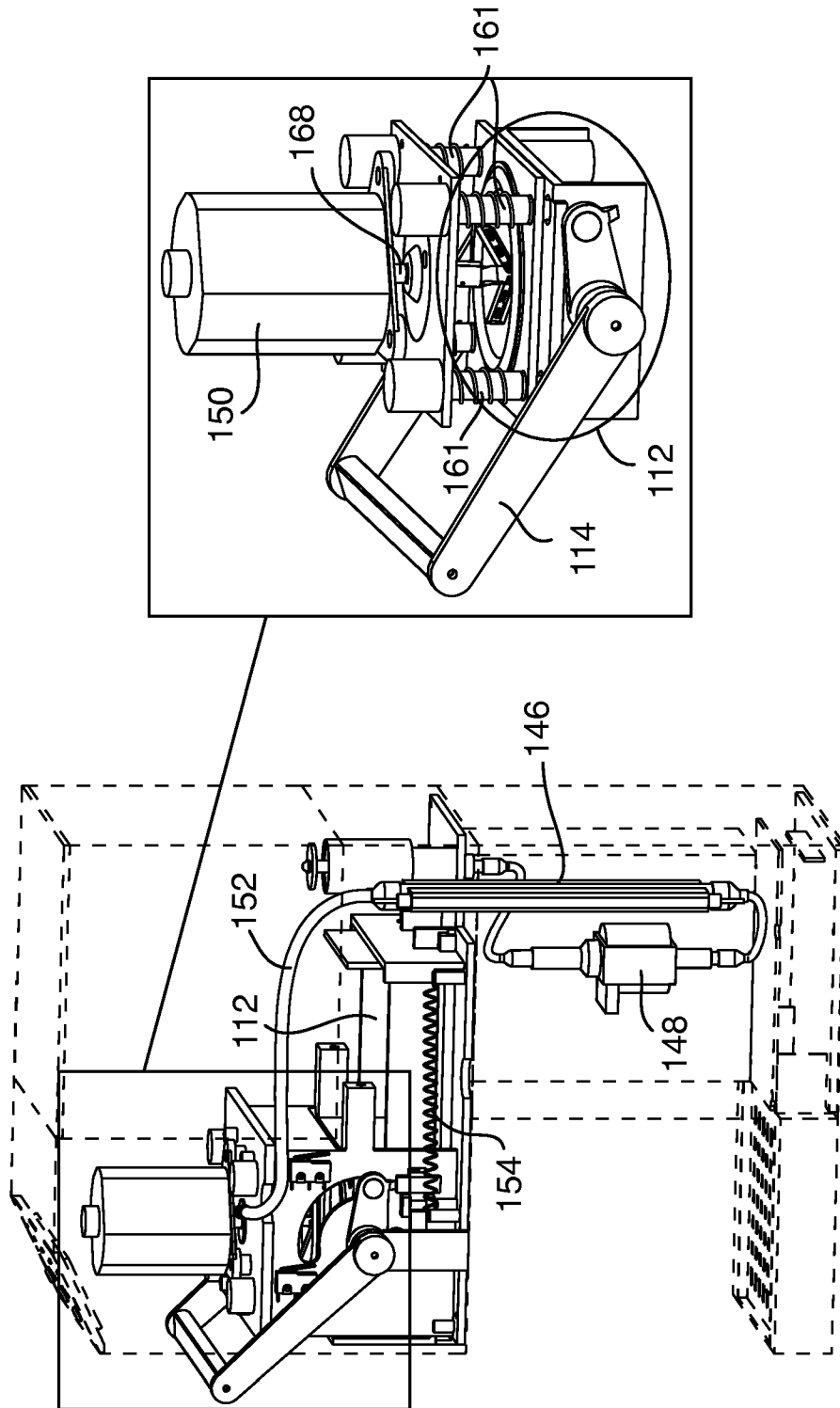

FIG. 30

17/41

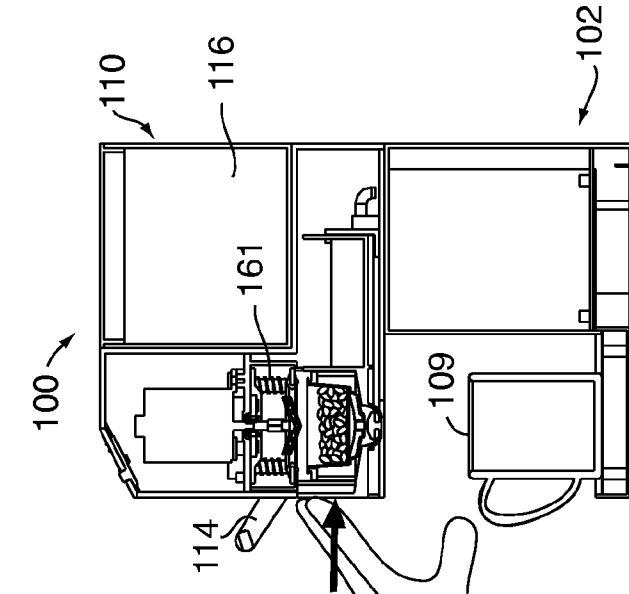

FIG. 31

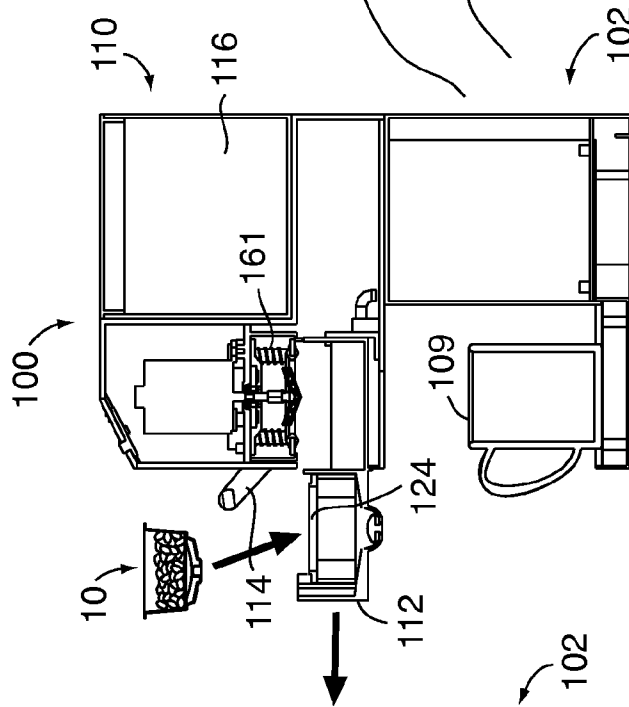

FIG. 32

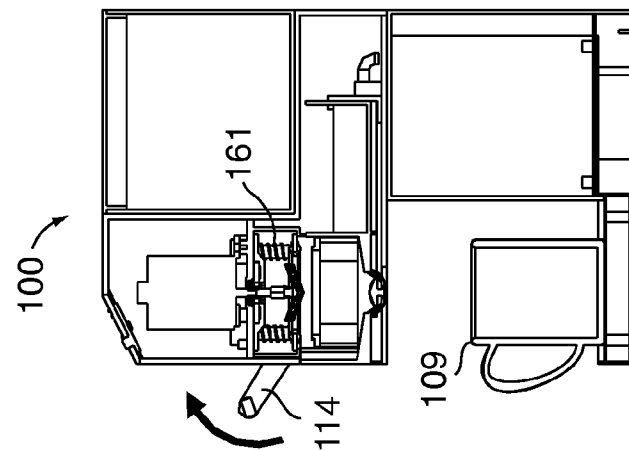

FIG. 33

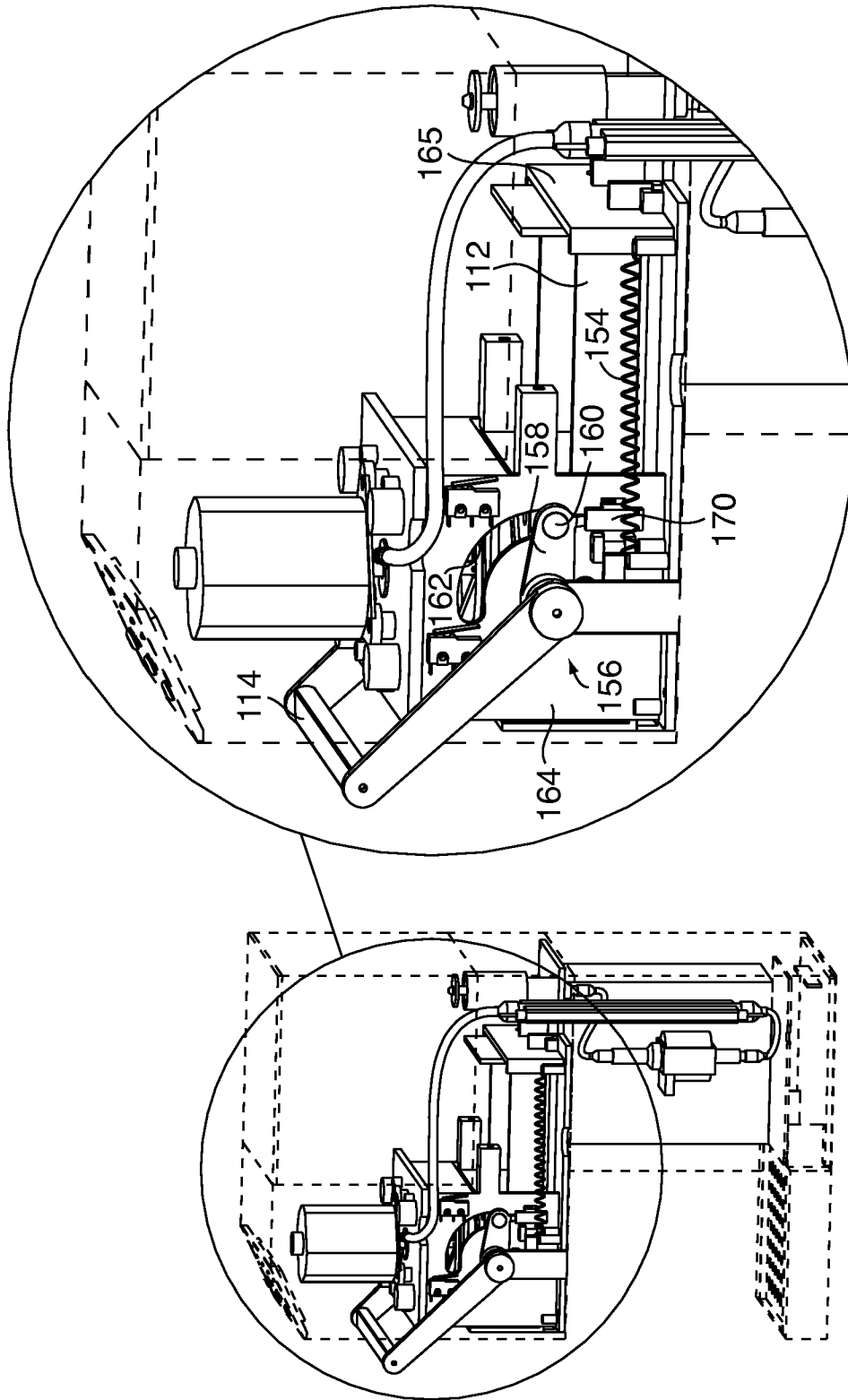

FIG. 34

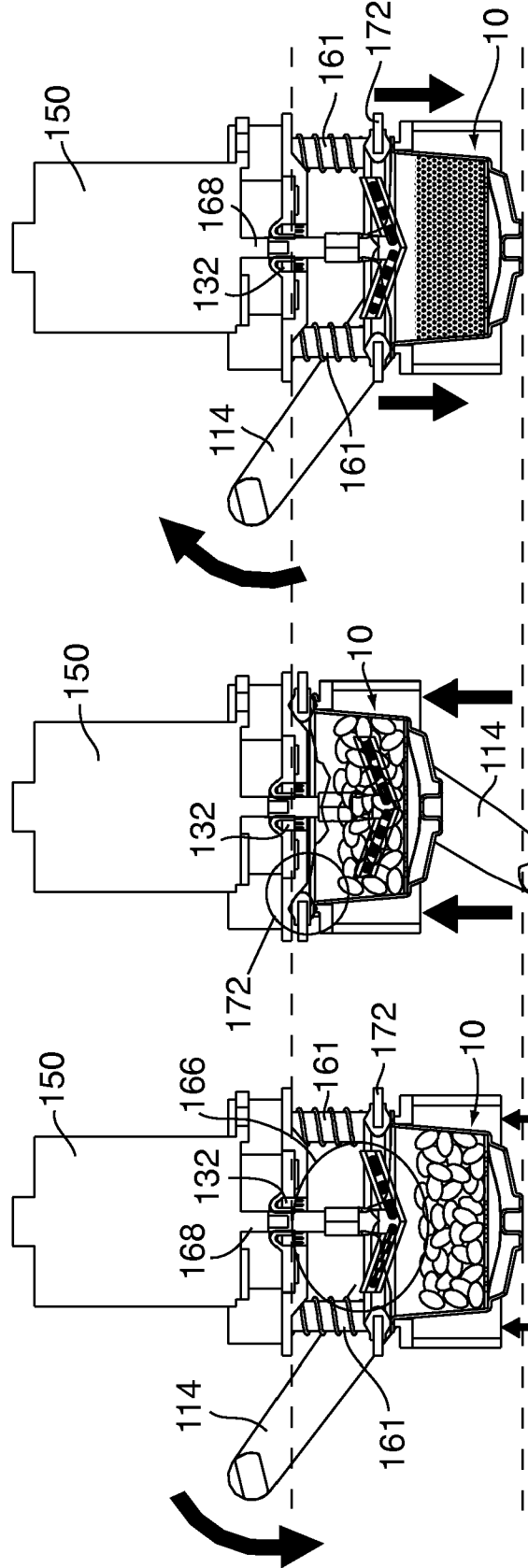
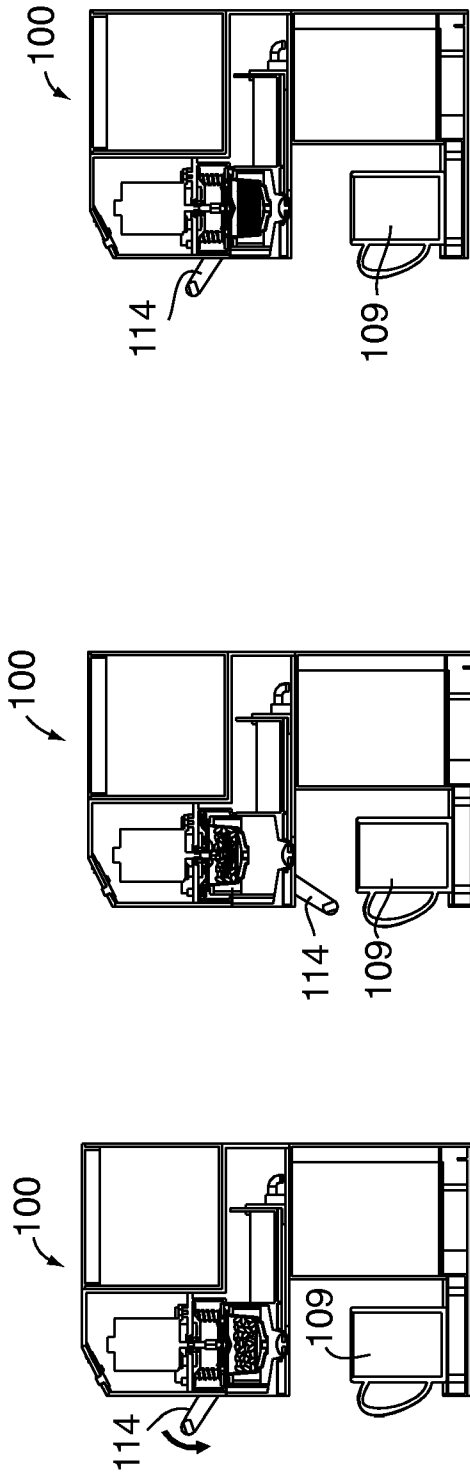

FIG. 37

FIG. 36

FIG. 35

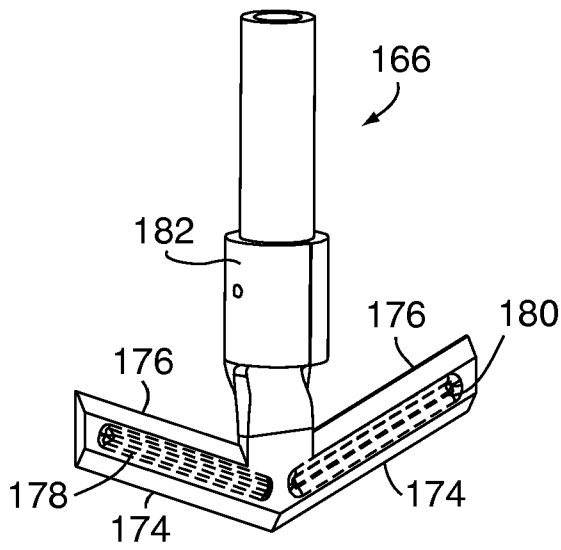

FIG. 38

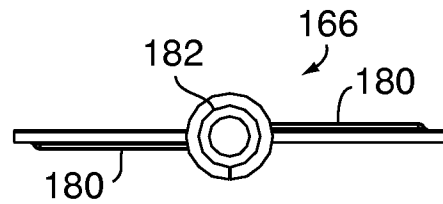

FIG. 39

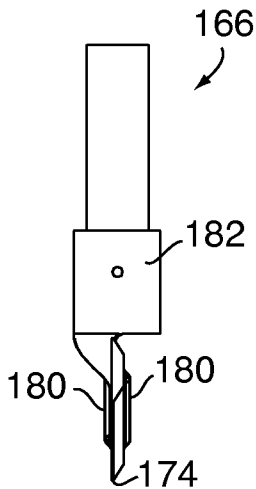

FIG. 40

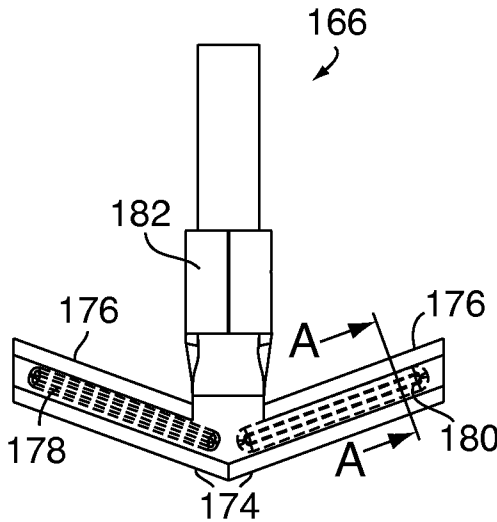

FIG. 41

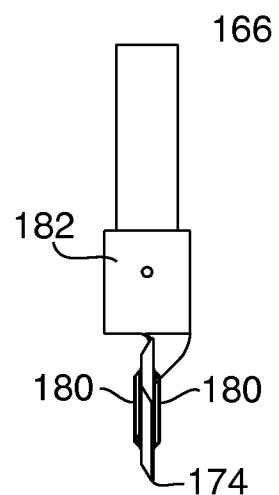

FIG. 42



FIG. 43

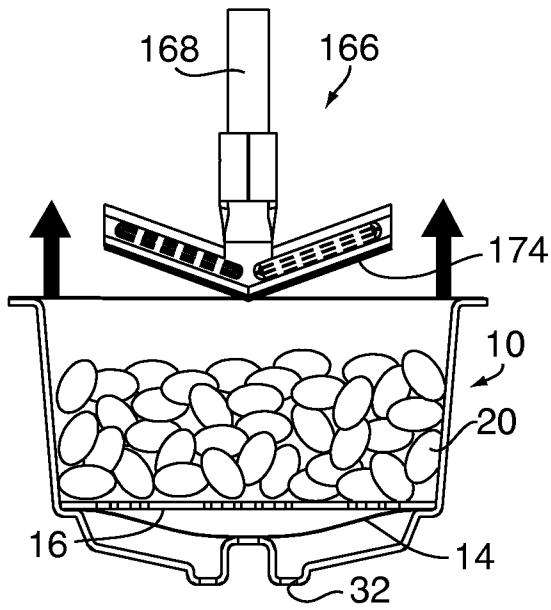

FIG. 44

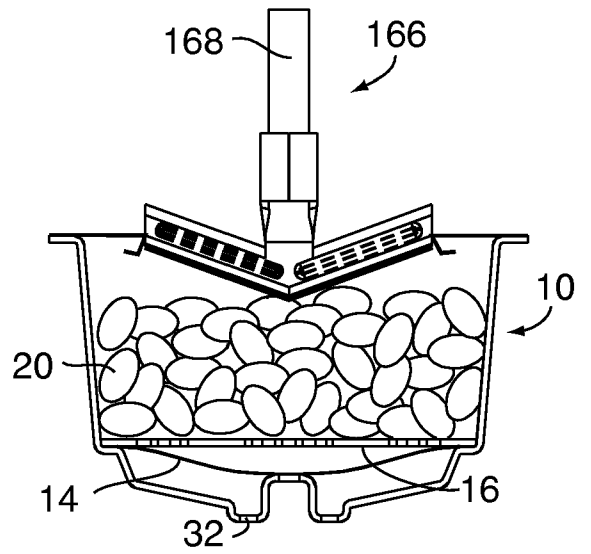

FIG. 45

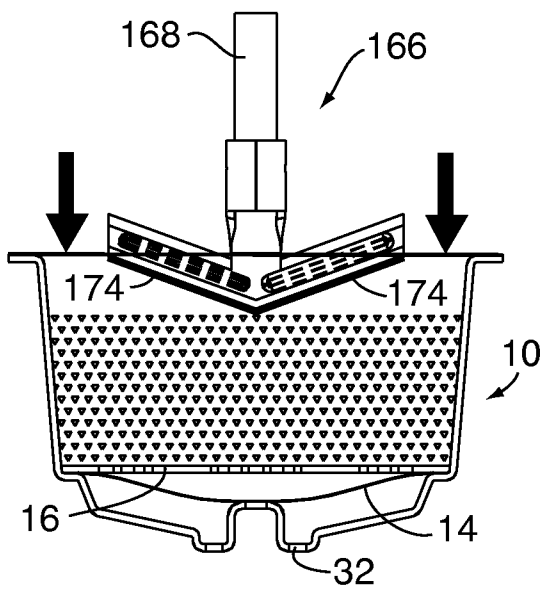

FIG. 46

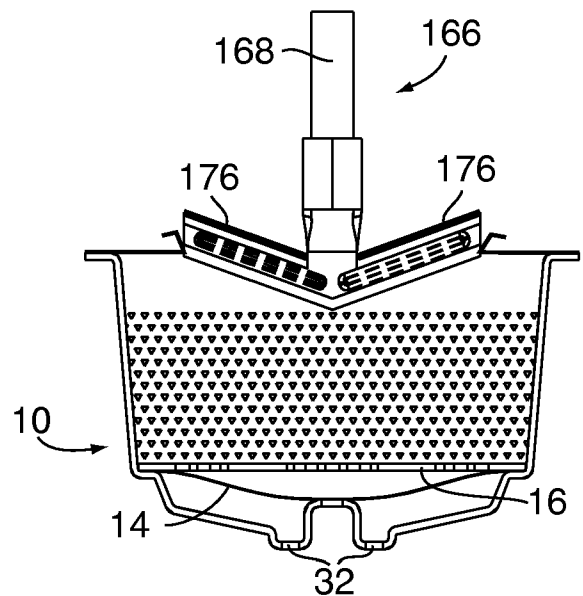

FIG. 47

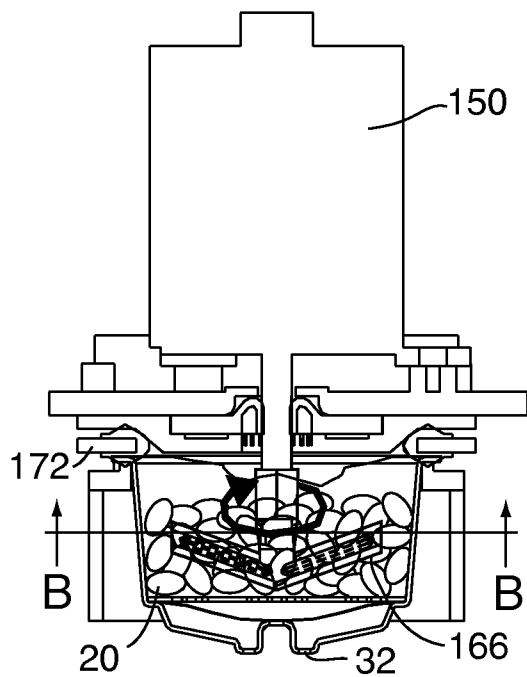

FIG. 48

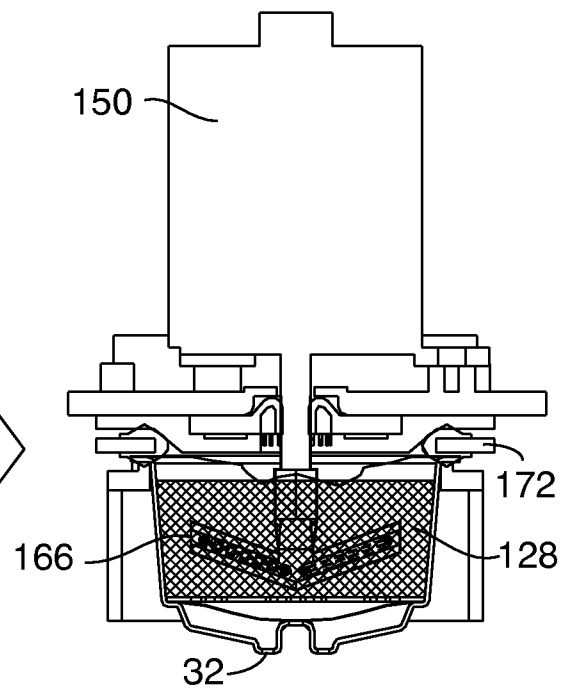
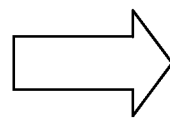

FIG. 50

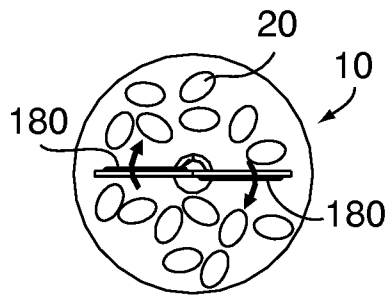

FIG. 49

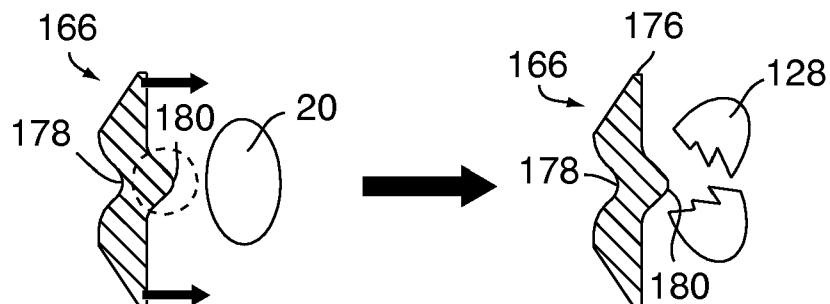

FIG. 51

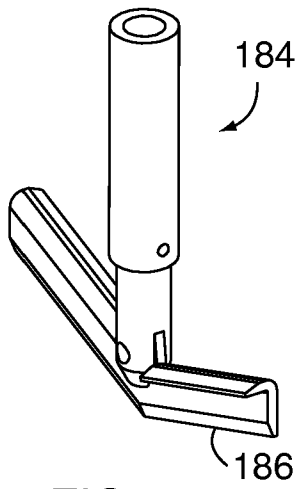

FIG. 52

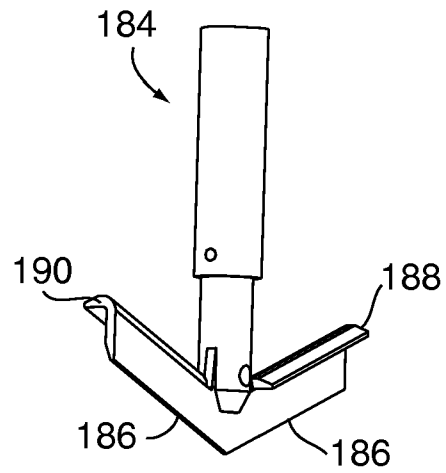

FIG. 53

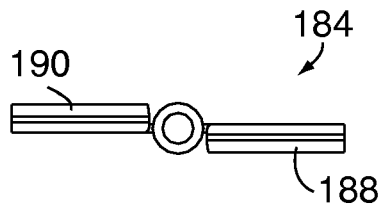

FIG. 54

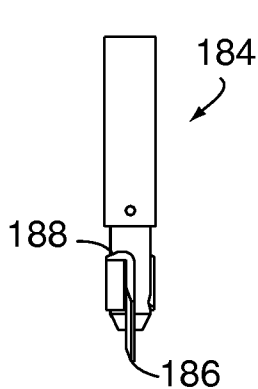

FIG. 55

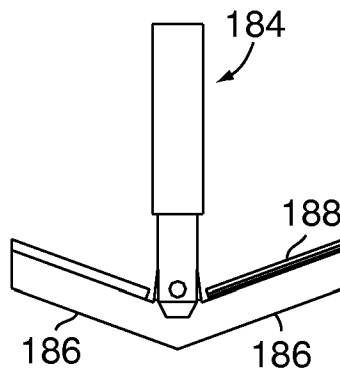

FIG. 56

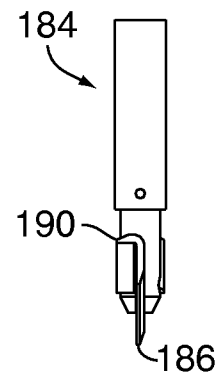

FIG. 57

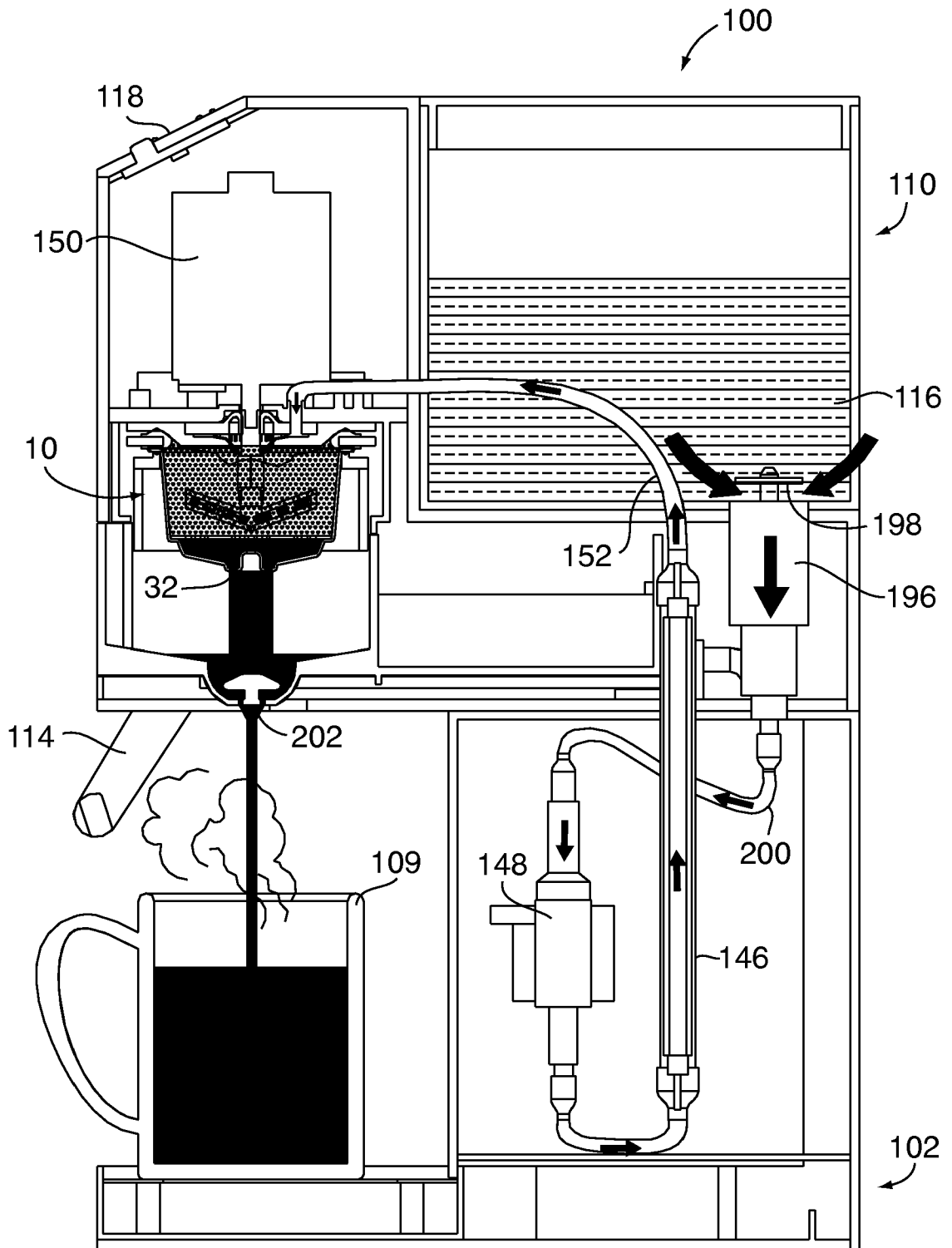

FIG. 58

25/41

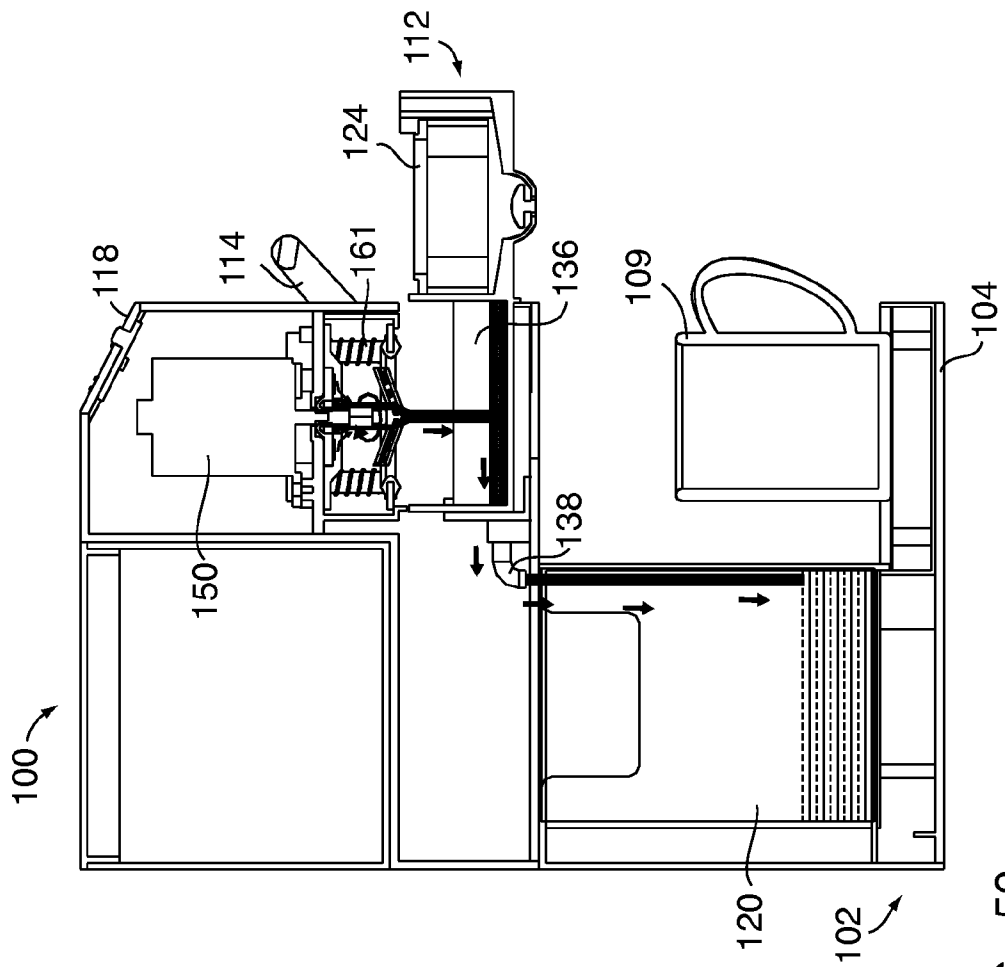
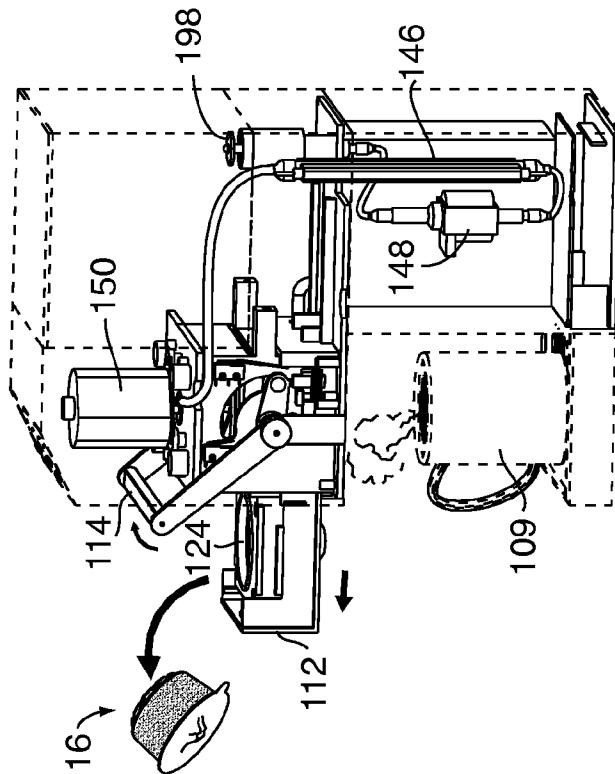

FIG. 59



26/41

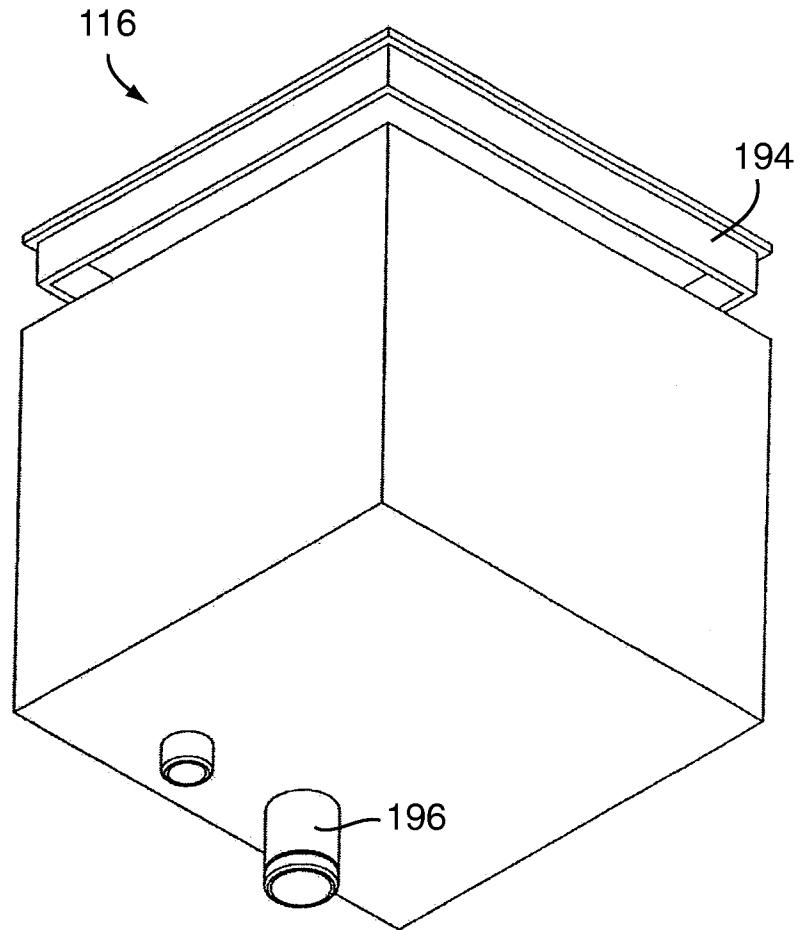

FIG. 60

27/41

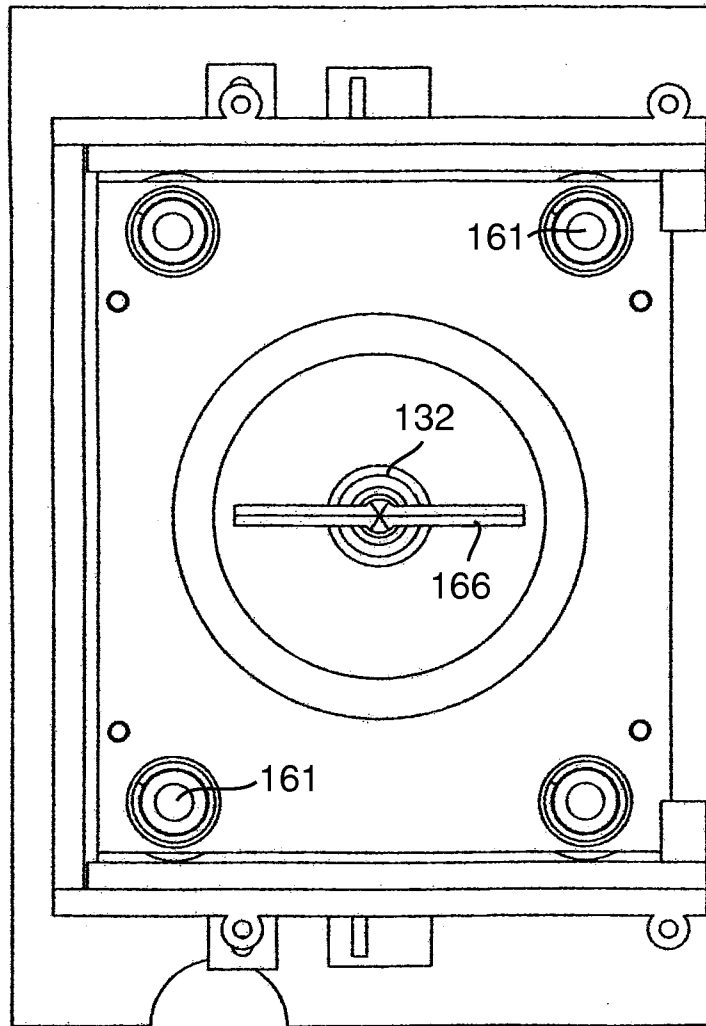

FIG. 61

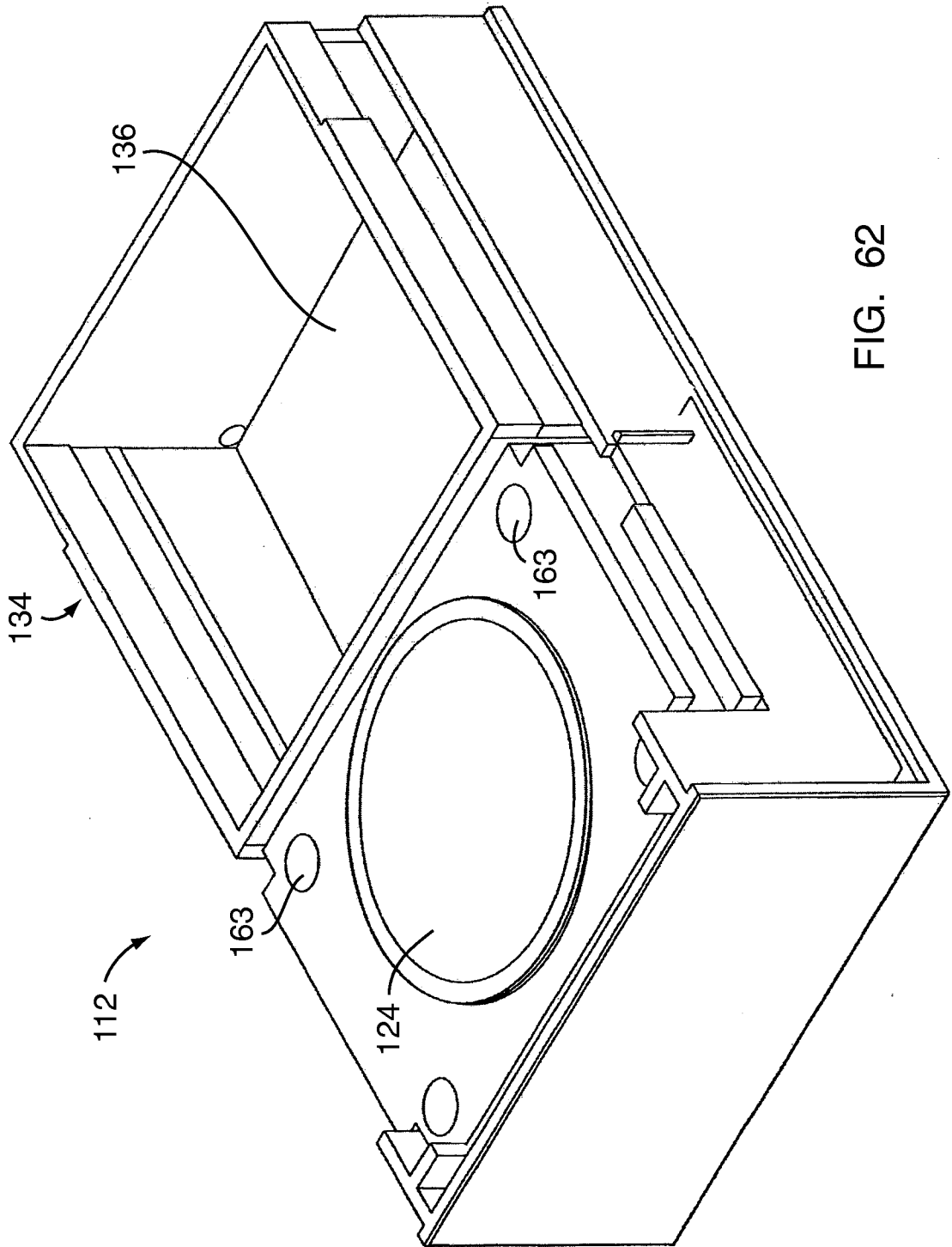

FIG. 62

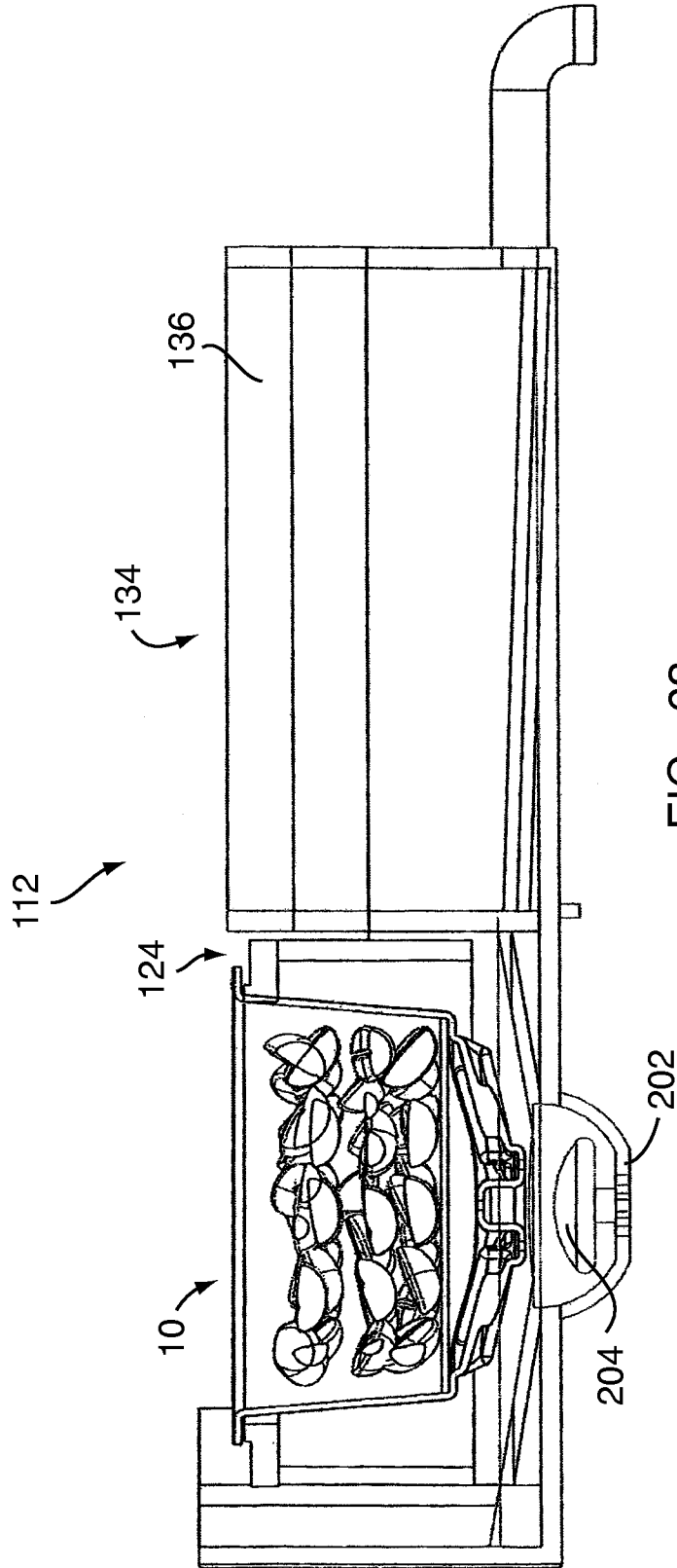

FIG. 63

30/41

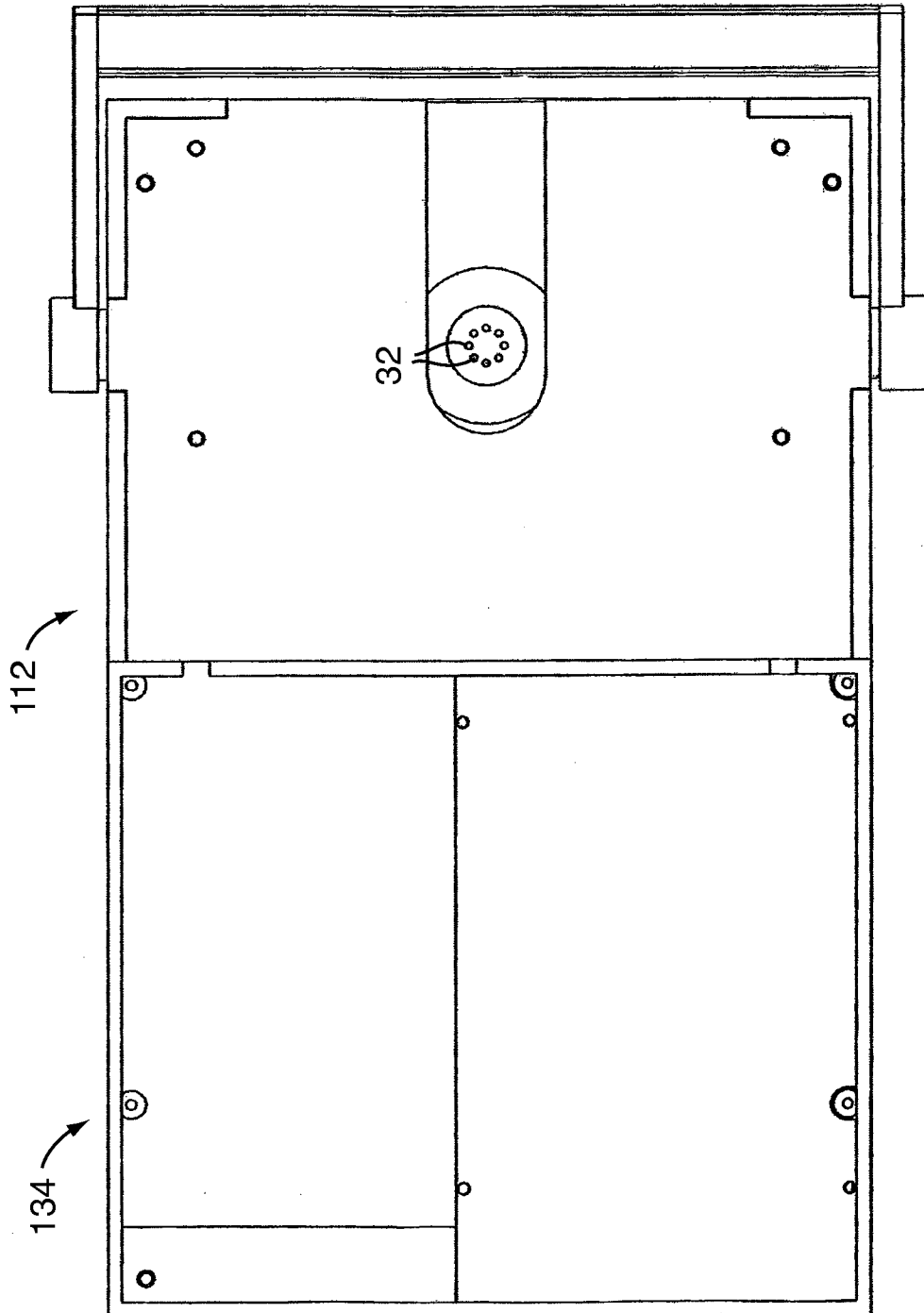

FIG. 64

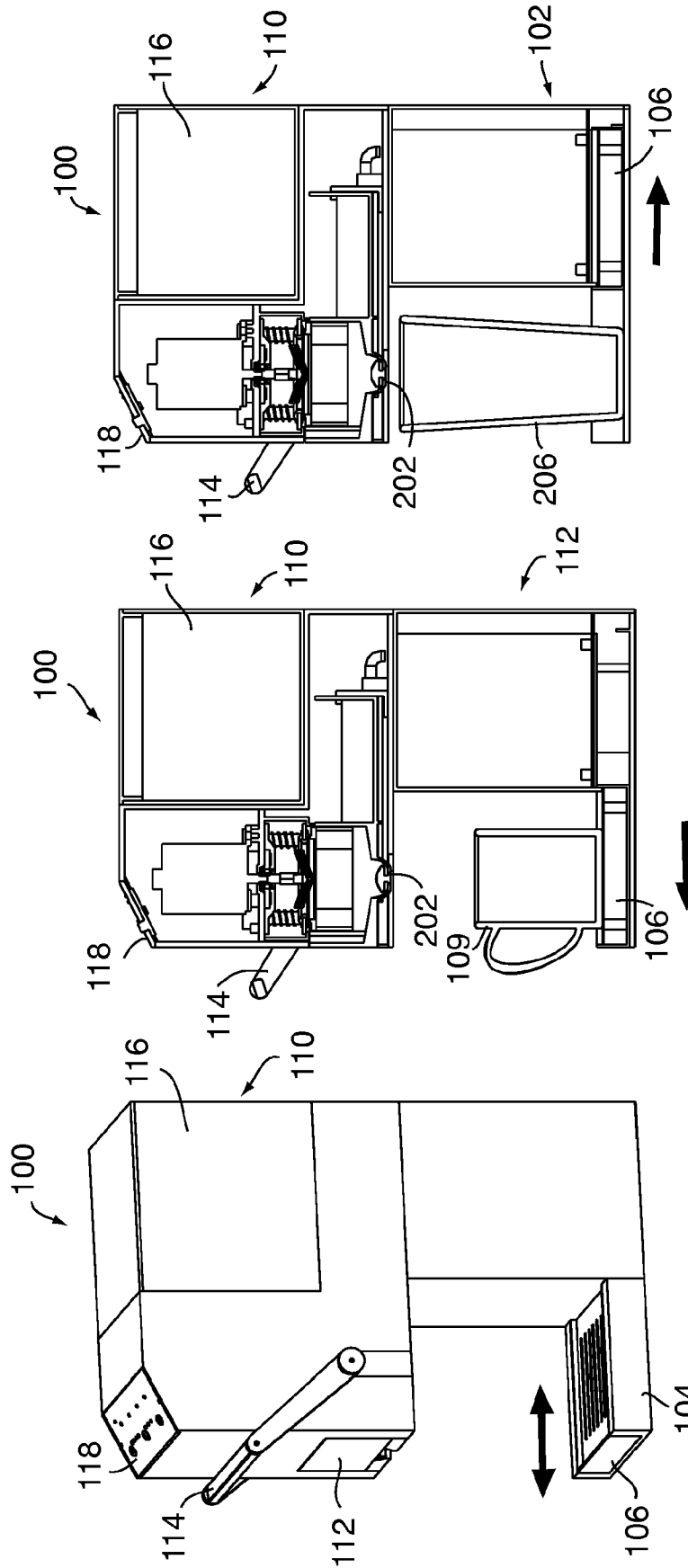

FIG. 67

FIG. 66

FIG. 65

32/41

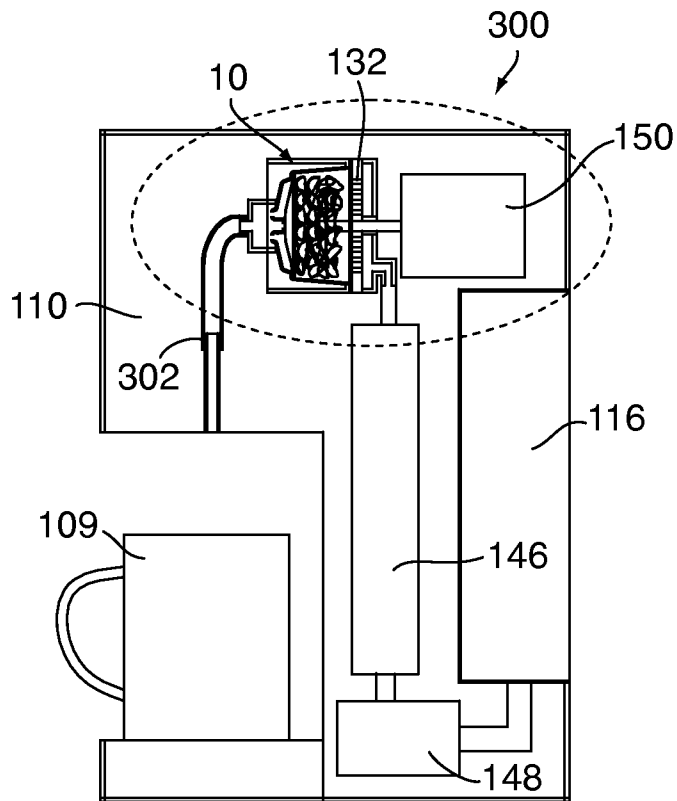

FIG. 68

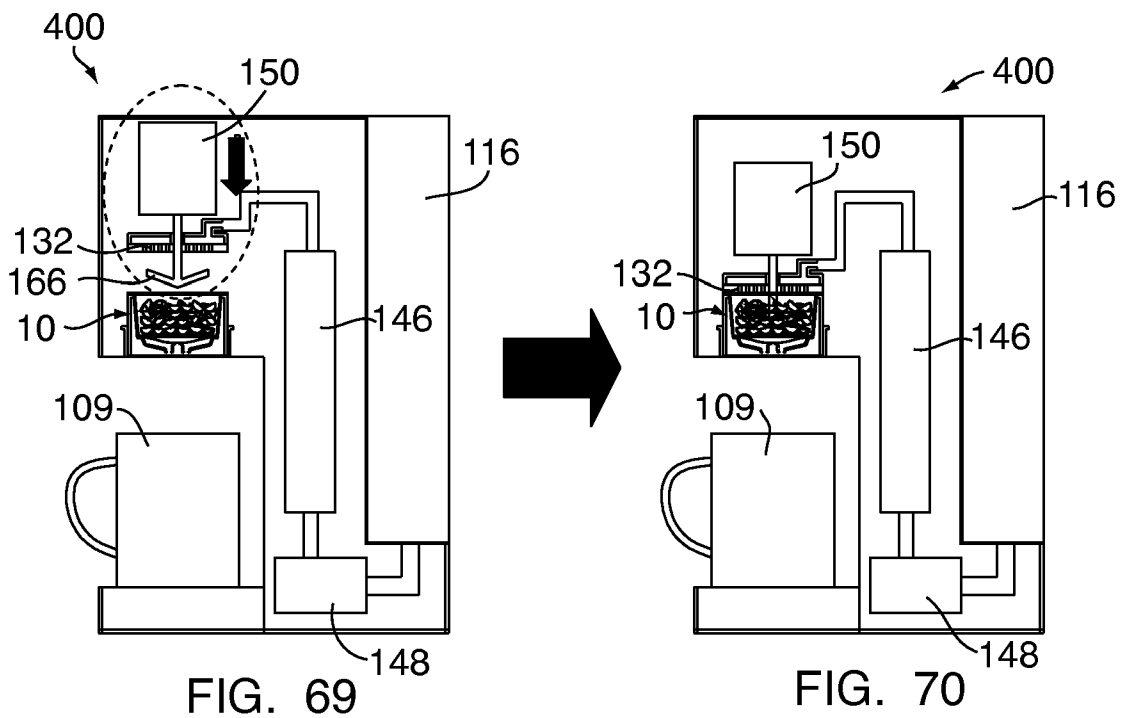

FIG. 69

FIG. 70

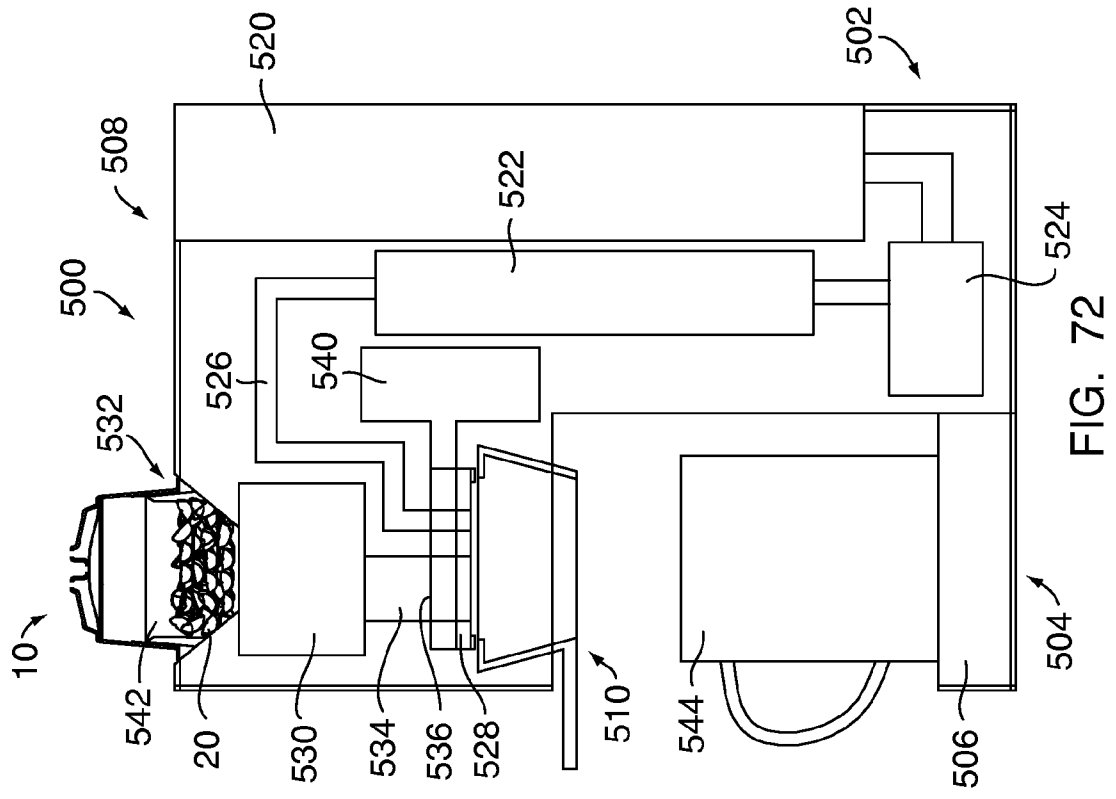

FIG. 72

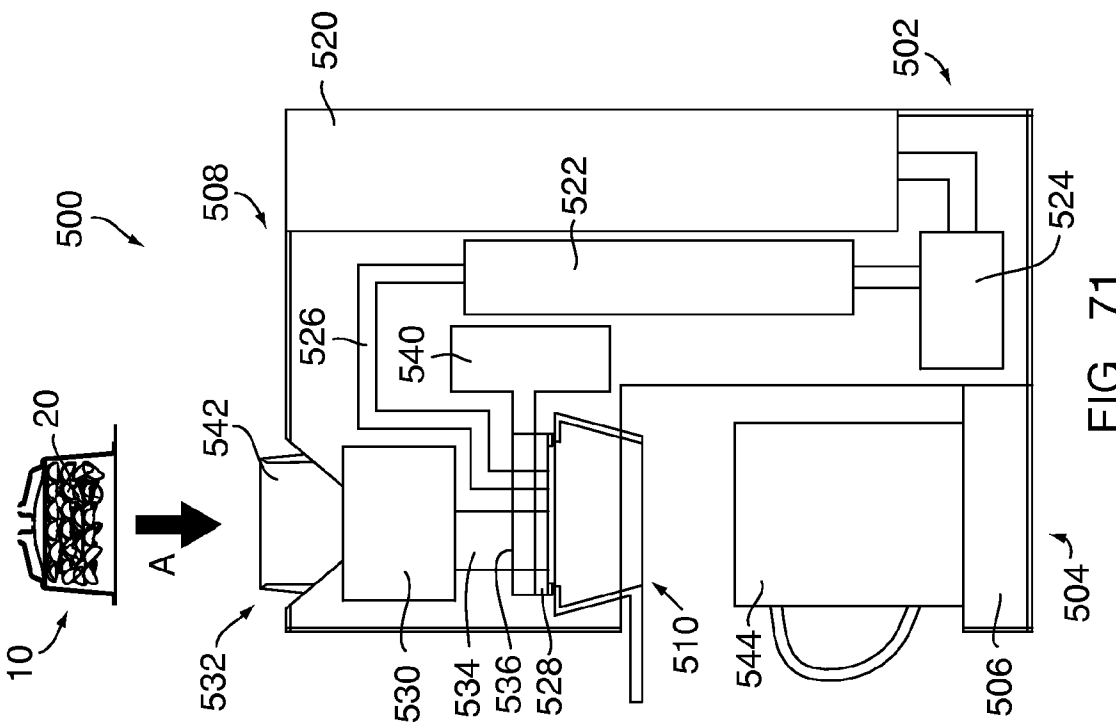
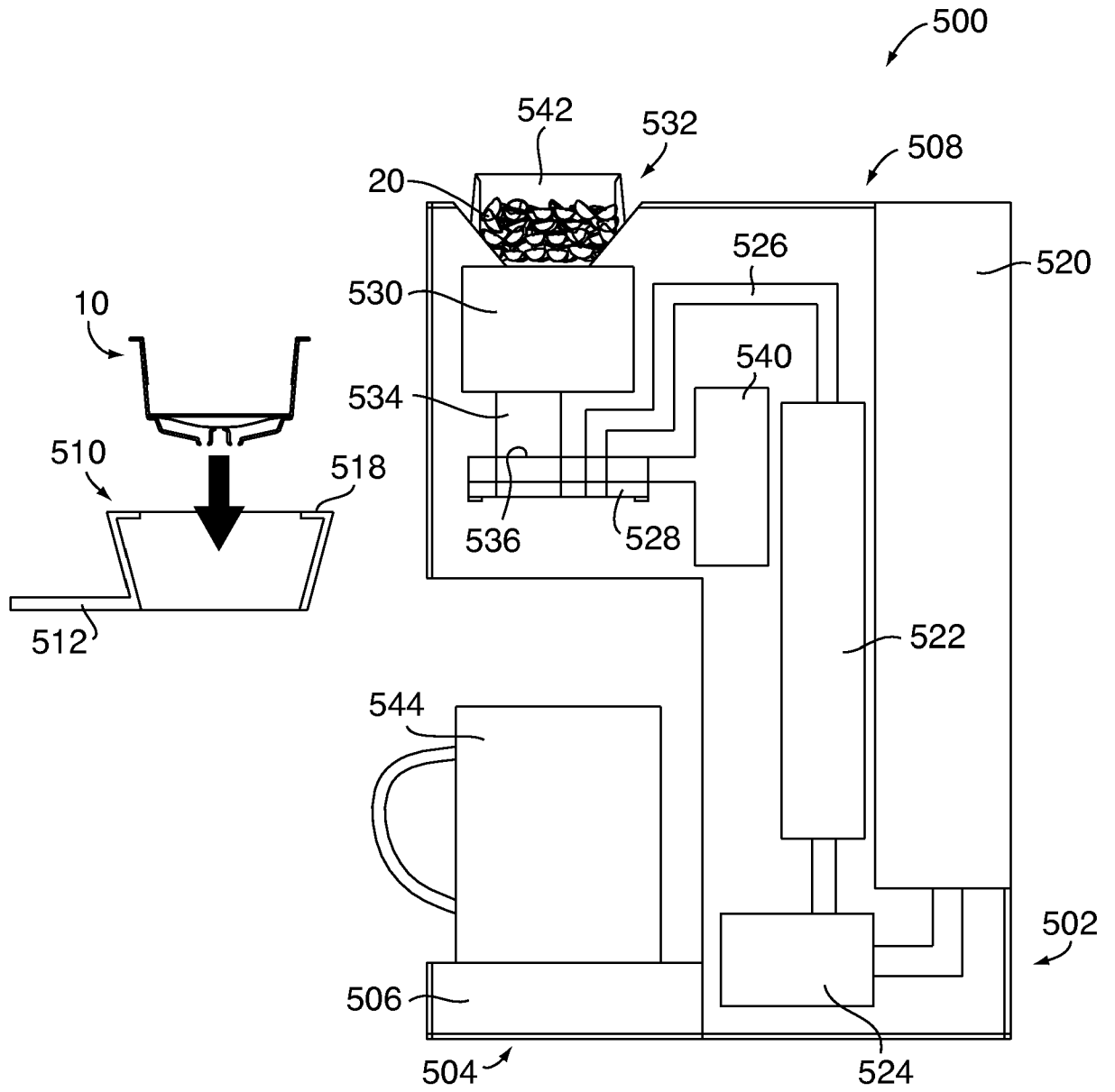

FIG. 71



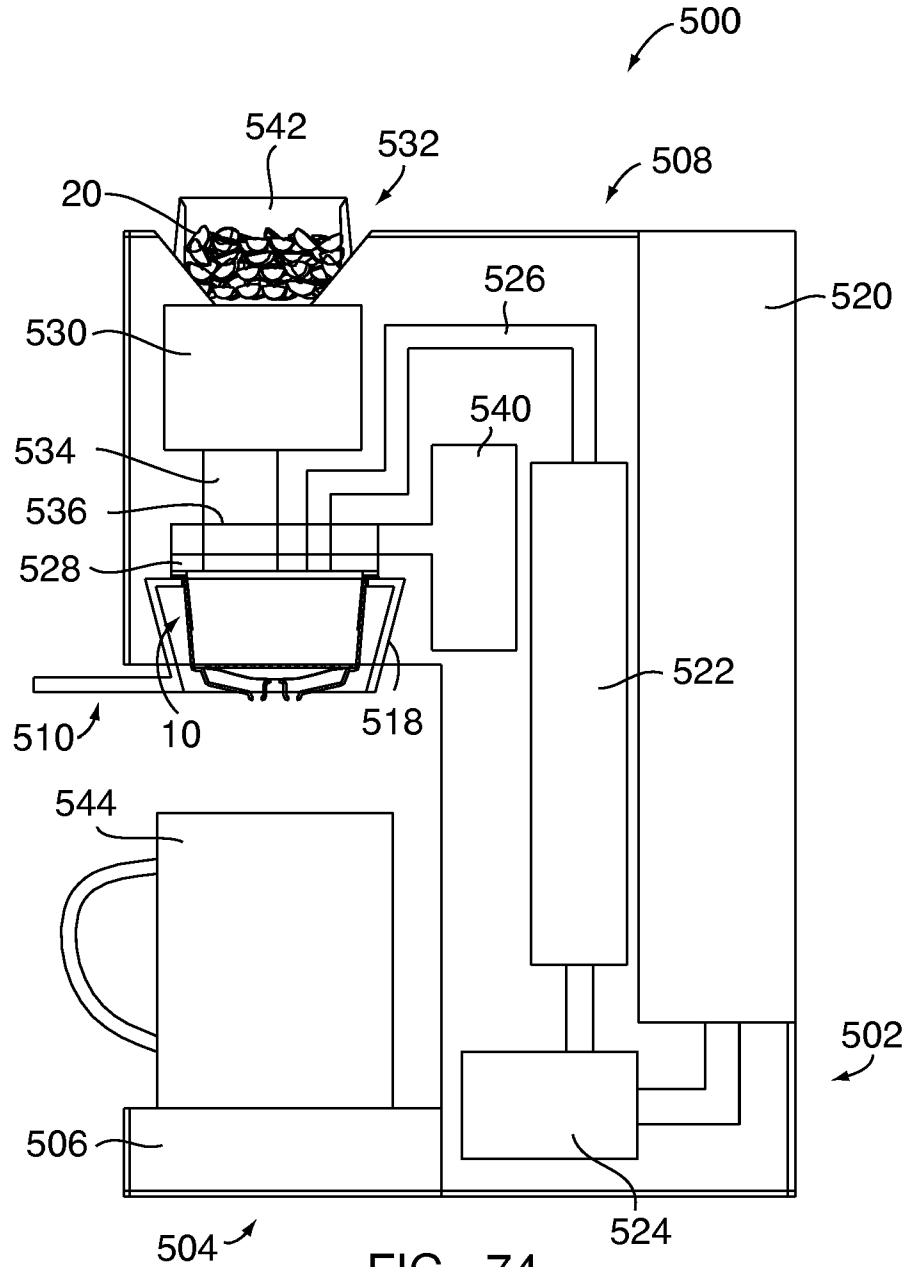

FIG. 74

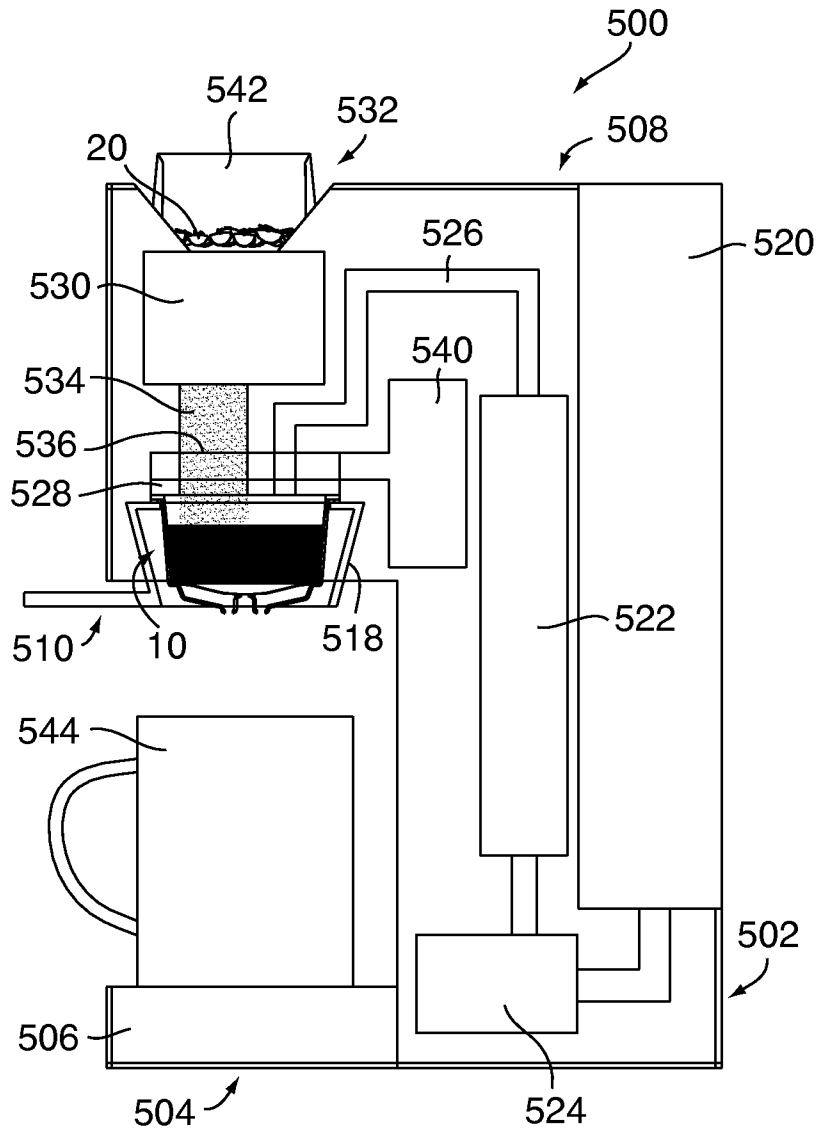
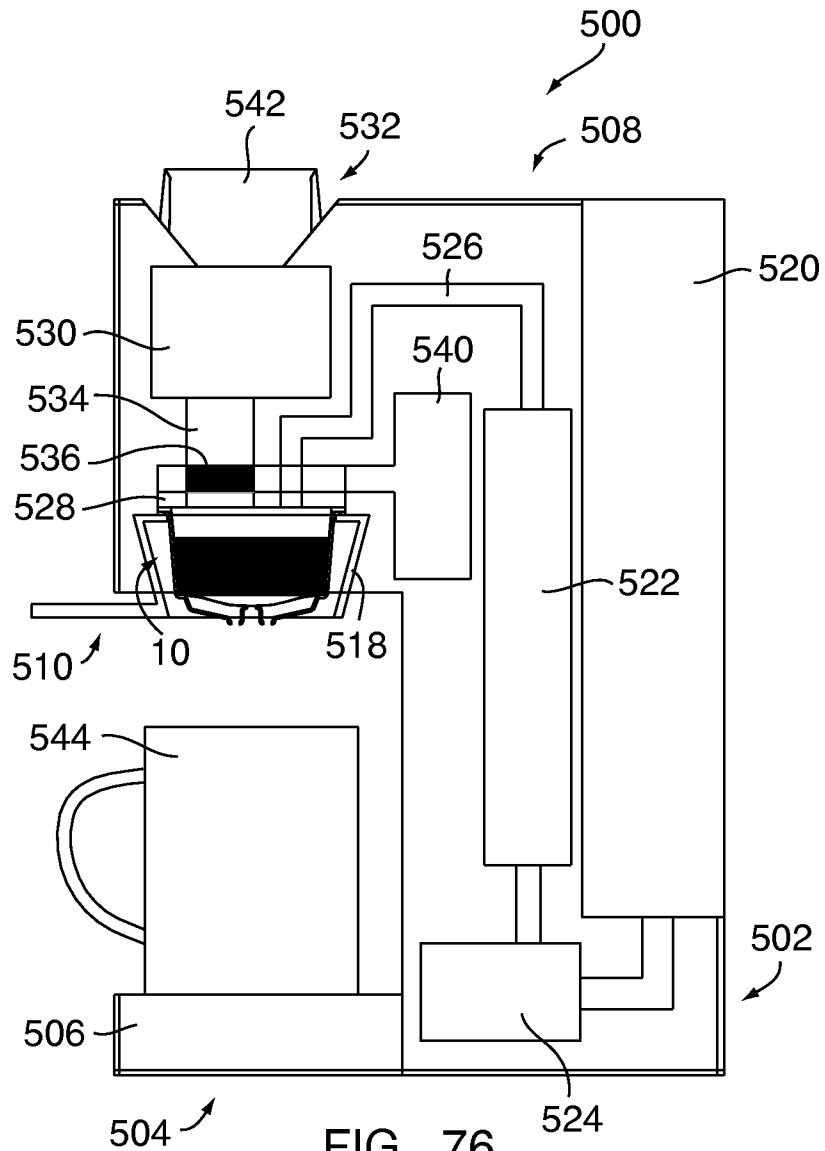

FIG. 75



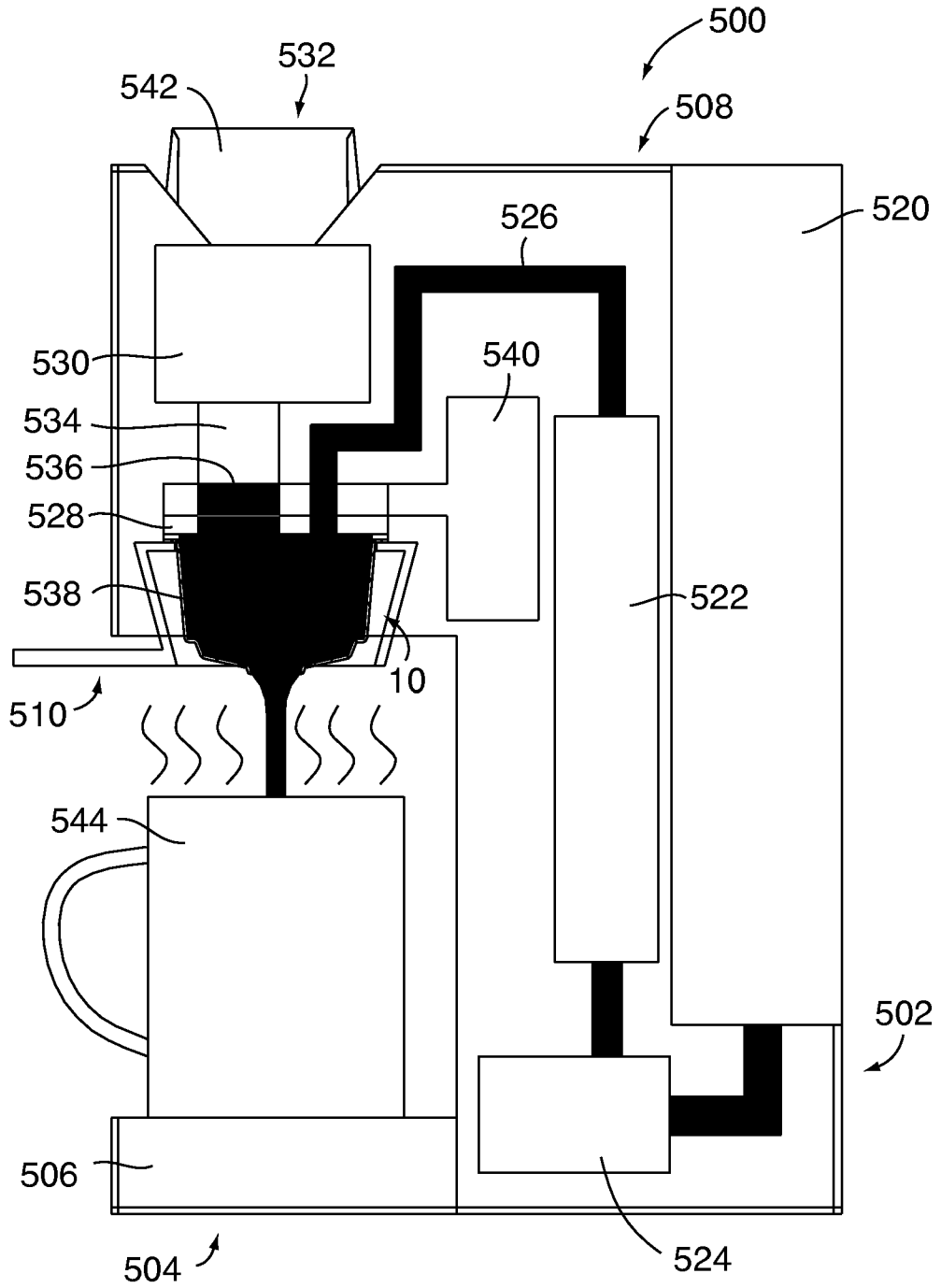

FIG. 77

39/41

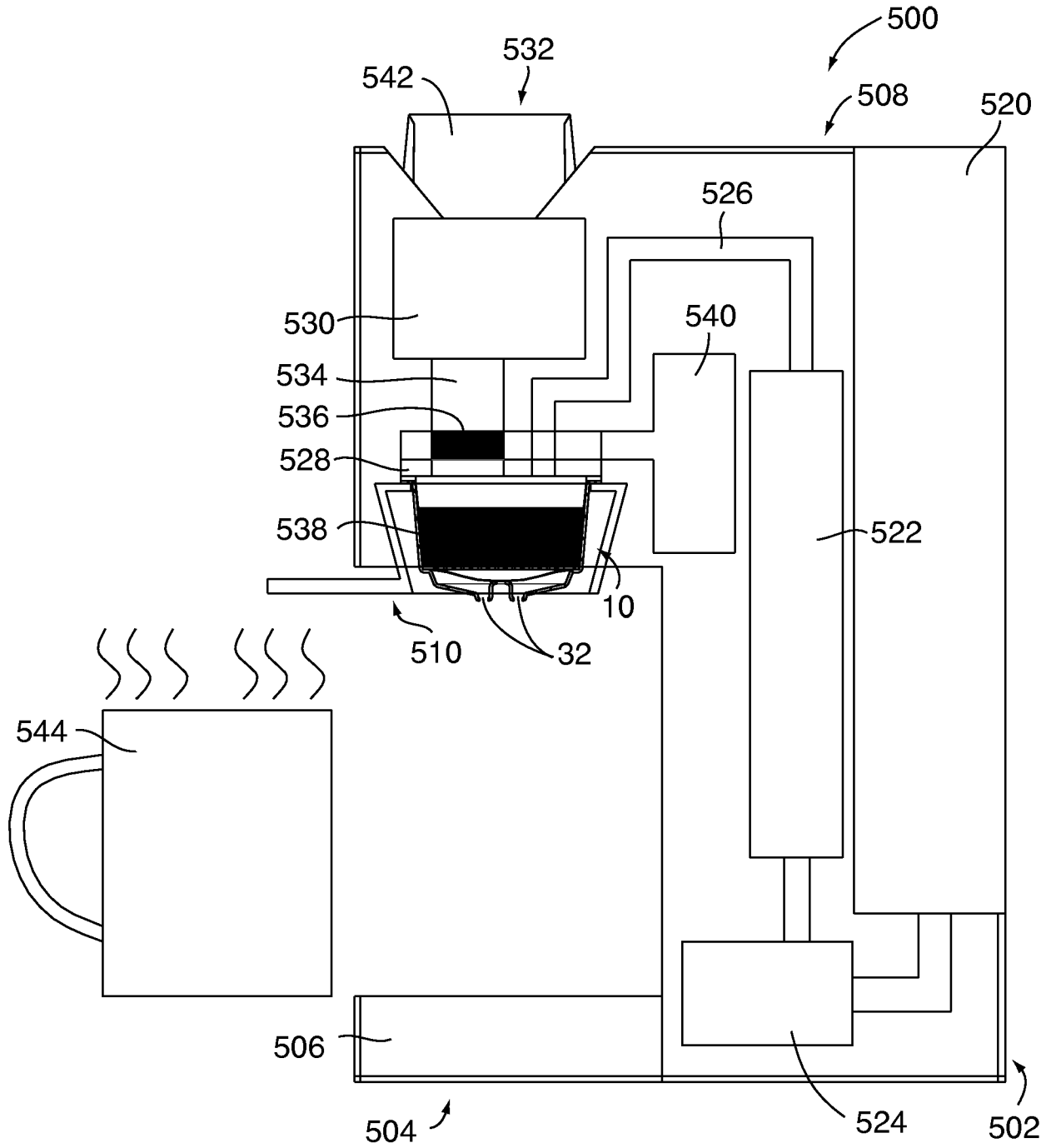

FIG. 78

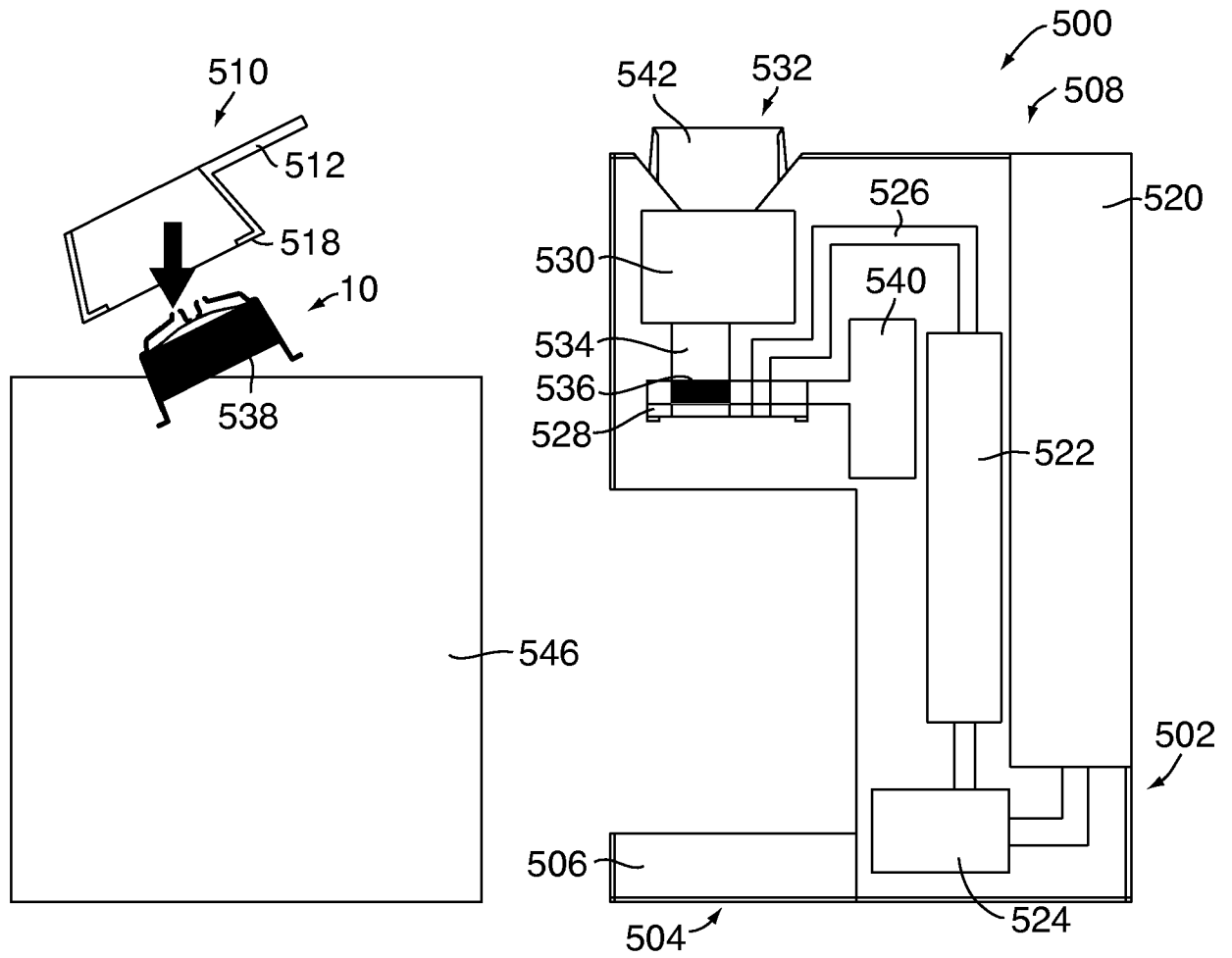

FIG. 79

41/41

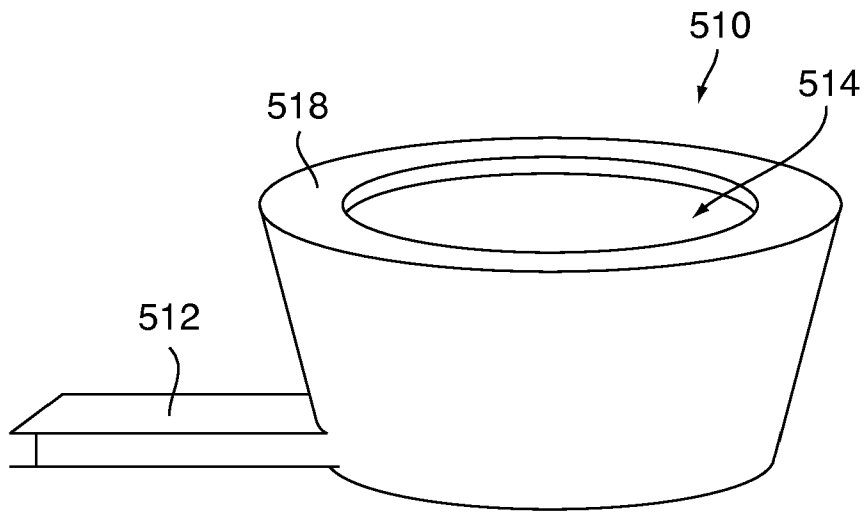

FIG. 80

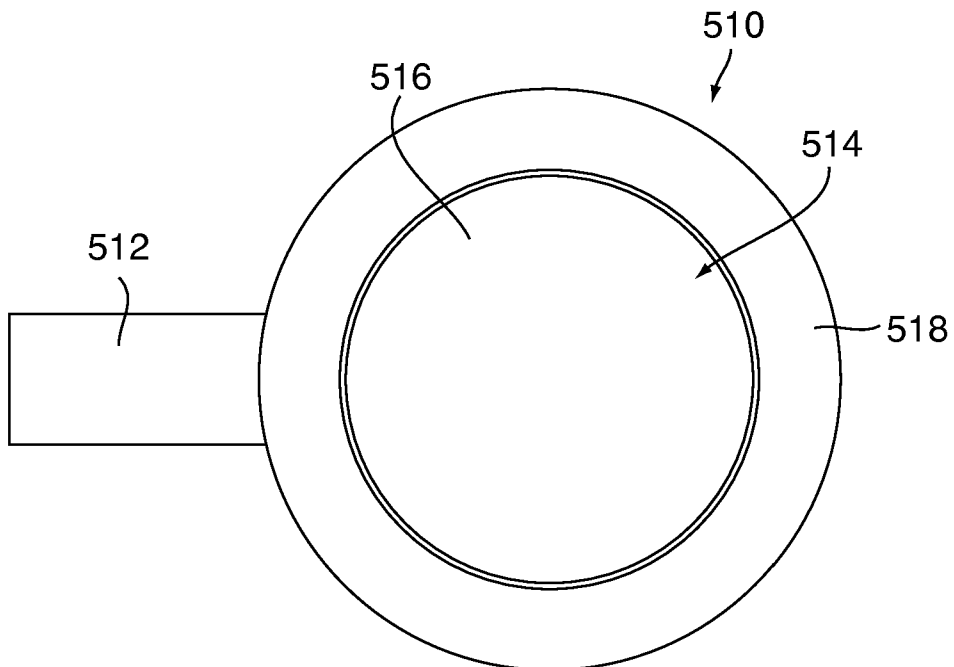

FIG. 81