

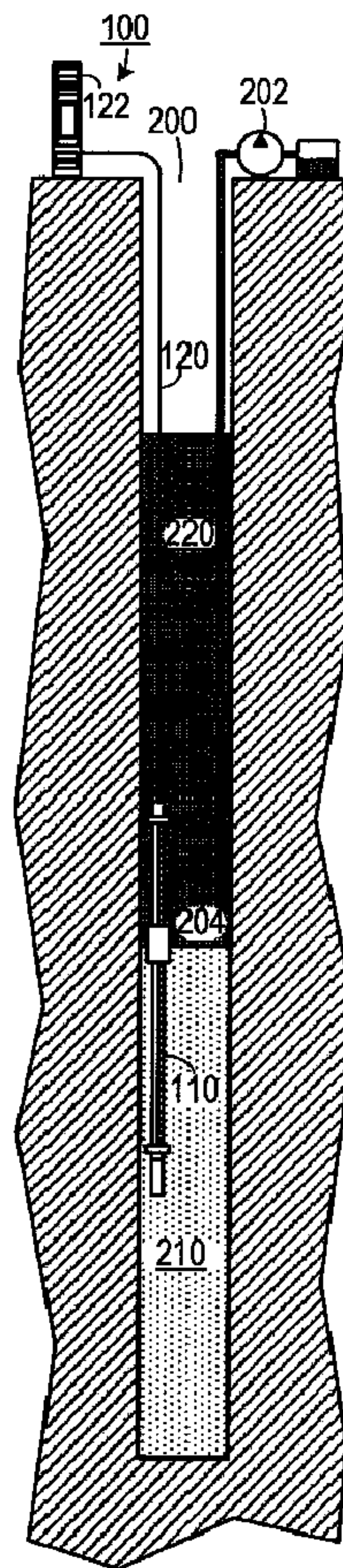

(22) **Date de dépôt/Filing Date:** 2008/03/25  
 (41) **Mise à la disp. pub./Open to Public Insp.:** 2008/09/22  
 (45) **Date de délivrance/Issue Date:** 2015/11/24  
 (30) **Priorité/Priority:** 2007/03/22 (US11/689,925)

(51) **Cl.Int./Int.Cl.** *G01F 23/30* (2006.01),  
*E21B 47/04* (2012.01), *G01F 23/72* (2006.01)  
 (72) **Inventeur/Inventor:**  
MAHADEVAIAH, BASAVARAJ, US  
 (73) **Propriétaire/Owner:**  
MAHADEVAIAH, BASAVARAJ, US  
 (74) **Agent:** BLAKE, CASSELS & GRAYDON LLP

(54) **Titre : ENREGISTREUR DE DONNEES DU NIVEAU DE FLUIDES MULTIPHASIQUES**  
 (54) **Title: MULTIPHASE-LIQUID LEVEL DATA LOGGER**



(57) **Abrégé/Abstract:**

A multiphase-liquid level sensing system for sensing a layer depth and thickness of a liquid of a first phase that floats on a liquid of a different second phase includes an elongated stem that defines an elongated cavity. A float, which exhibits a sensible property, is

**(57) Abrégé(suite)/Abstract(continued):**

disposed coaxially around the elongated stem and has negative buoyancy relative to the liquid of the first phase and positive buoyancy relative to the liquid of the second phase. A level sensor senses the sensible property and indicates a second phase liquid distance from the float to the bottom of the stem. An overburden sensor extends downwardly from the stem senses total liquid thickness of the liquid above the overburden sensor. A computational circuit calculates a layer depth and thickness of the liquid of the first phase, based on input from the level sensor and the overburden sensor.

**ABSTRACT**

1  
2  
3       A multiphase-liquid level sensing system for sensing a layer depth and thickness of a  
4 liquid of a first phase that floats on a liquid of a different second phase includes an elongated  
5 stem that defines an elongated cavity. A float, which exhibits a sensible property, is disposed  
6 coaxially around the elongated stem and has negative buoyancy relative to the liquid of the first  
7 phase and positive buoyancy relative to the liquid of the second phase. A level sensor senses the  
8 sensible property and indicates a second phase liquid distance from the float to the bottom of the  
9 stem. An overburden sensor extends downwardly from the stem senses total liquid thickness of  
10 the liquid above the overburden sensor. A computational circuit calculates a layer depth and  
11 thickness of the liquid of the first phase, based on input from the level sensor and the overburden  
12 sensor.

# MULTIPHASE-LIQUID LEVEL DATA LOGGER

## BACKGROUND OF THE INVENTION

### [0001] Field of the Invention

[0002] The present invention relates to sensor systems and, more specifically, to a sensor system that senses the thickness of layers of liquids of different phases.

### [0003] Description of the Prior Art

[0004] It is important to measure multiphase fluid levels in a variety of settings such as containers, drums, tanks, wells, rivers, oceans, and other surface and subsurface environments. Multiphase fluids are composed of liquids of different specific gravities such as light non-aqueous phase liquid (LNAPL), water, dense non-aqueous phase liquid (DNAPL), and emulsions. LNAPL is characterized by having a specific gravity less than that of water and DNAPL is characterized by having a specific gravity greater than that of water.

[0005] Current systems for measuring multiphase fluid levels include systems that use pressure transducers, optical sensors, float switches, ultrasonic sensors, magneto-restrictive, magneto-elastic, radar (pulse burst, guided-wave, frequency modulated continuous wave, and other radar-based technologies ), radio frequency (RF), and related devices which are capable of measuring the level of a single phase liquid.

[0006] None of these devices are capable of measuring levels of several multiphase liquids simultaneously. Although two or more devices can be applied to measure the levels of multiphase liquids separately, none of the devices are capable of automatically computing and reporting the thicknesses of multiphase liquids or the elevations of multiphase liquids, simultaneously.

1 [0007] The space available to install multiple devices to measure multiphase liquids may be  
2 restricted by the narrow spaces of the container being measured. For example, a tank may not  
3 have a sufficient number of ports to accommodate more than one device, or a single available  
4 port might not be large enough to accommodate multiple devices. In measuring multiphase  
5 liquid levels in a well, the space within the well is generally too restricted to accommodate  
6 several different devices at the same time. Furthermore, it may not be possible to deploy other  
7 down-hole devices such as pumping systems or other recovery apparatus in small diameter wells.  
8

9 [0008] Therefore, there is a need for a system that can sense the levels of different liquid  
10 phases simultaneously.  
11

## 12 SUMMARY OF THE INVENTION

13

14 [0009] The disadvantages of the prior art are overcome by the present invention which, in  
15 one aspect, is a multiphase-liquid level sensing system for sensing a layer depth and thickness of  
16 a liquid of a first phase that floats on a liquid of a different second phase. An elongated stem has  
17 a top end and an opposite bottom end, a top retainer disposed adjacent the top end and a bottom  
18 retainer disposed adjacent the bottom end. The elongated stem defines an elongated cavity  
19 therein. A first float is disposed coaxially around the elongated stem. A portion of the first float  
20 exhibits a sensible property. The first float has a negative buoyancy relative to the liquid of the  
21 first phase and a positive buoyancy relative to the liquid of the second phase. A level sensor is  
22 disposed within the cavity defined by the elongated stem. The level sensor senses the sensible  
23 property of the portion of the first float. The level sensor is configured to indicate a second  
24 phase liquid distance from the first float to the bottom end of the stem based on where the  
25 sensible property is sensed on the level sensor. An overburden sensor extends downwardly from  
26 the bottom end of the stem. The overburden sensor is configured to sense a property indicative  
27 of a total liquid thickness of the liquid of the first phase and the liquid of the second phase above  
28 the overburden sensor. A depth indicator indicates a depth of the overburden sensor relative to a  
29 predetermined point. A computational circuit calculates a layer depth and thickness of the liquid  
30 of the first phase, based on a first signal from the level sensor, a second signal from the  
31 overburden sensor and the depth of the overburden sensor.

1  
2 **[0010]** In another aspect, the invention is a multiphase-liquid level sensing system for  
3 sensing a layer depth and thickness of a liquid of a first phase that floats on a liquid of a different  
4 second phase. An elongated stem has a top end and an opposite bottom end, a top retainer  
5 disposed adjacent the top end and a bottom end disposed adjacent the bottom end. The elongated  
6 stem defines an elongated cavity therein. A first float is disposed coaxially around the elongated  
7 stem. The first float includes an annular floatation member having a top end and an opposite  
8 bottom end and a magnet that is affixed to the annular floatation member. The magnet is  
9 configured to generate a sensible magnetic field. The first float has a negative buoyancy relative  
10 to the liquid of the first phase and a positive buoyancy relative to the liquid of the second phase.  
11 A plurality of spaced-apart reed switches is disposed within the cavity defined by the elongated  
12 stem the level sensor. Each reed switch is capable of switching from a first state to a different  
13 second state when subjected to a magnetic field so as to indicate a position of the second float,  
14 thereby indicating a second phase liquid distance from the first float to the bottom end of the  
15 stem. A pressure transducer extends downwardly from the bottom end of the stem. The pressure  
16 transducer is configured to sense a pressure indicative of a total liquid thickness of the liquid of  
17 the first phase and the liquid of the second phase above the pressure transducer. A depth  
18 indicator indicates a depth of the pressure transducer relative to a predetermined point. A  
19 computational circuit calculates a layer depth and thickness of the liquid of the first phase. The  
20 computational circuit is responsive to a first signal from the level sensor, a second signal from  
21 the pressure transducer and the depth of the pressure transducer.

22  
23 **[0011]** In yet another aspect, the invention is a method of determining a thickness and a  
24 depth of a layer of a liquid of a first phase that is floating on a layer of a liquid of a different  
25 second phase, in which a first depth of a portion of a sensor that is placed in the liquid of the  
26 second phase is detected. A total liquid thickness between the sensor and the top of the layer of  
27 liquid of the first phase is detected. A first distance from the portion of the sensor to an interface  
28 between the liquid of the first phase and the liquid of the second phase is detected. The thickness  
29 of the layer of the liquid of the first phase is calculated by subtracting the first distance from the  
30 total liquid thickness.

31

1 [0012] These and other aspects of the invention will become apparent from the following  
2 description of the preferred embodiments taken in conjunction with the following drawings. As  
3 would be obvious to one skilled in the art, many variations and modifications of the invention  
4 may be effected without departing from the spirit and scope of the novel concepts of the  
5 disclosure.

6

7 **BRIEF DESCRIPTION OF THE FIGURES OF THE DRAWINGS**

8

9 [0013] **FIG. 1A** is a schematic diagram of a multiphase-liquid level sensing system.

10

11 [0014] **FIG. 1B** is a schematic diagram of a multiphase-liquid level sensing system  
12 employed to measure levels in a well.

13

14 [0015] **FIG. 1C** is a schematic diagram of a multiphase-liquid level sensing system used to  
15 measure levels in a well that is adjacent to another well.

16

17 [0016] **FIG. 2** is a schematic diagram of a one float multiphase-liquid level sensing system  
18 for sensing a LNAPL and water layer thicknesses.

19

20 [0017] **FIG. 3** is a schematic diagram of a one float multiphase-liquid level sensing system  
21 for sensing a DNAPL and water layer thicknesses.

22

23 [0018] **FIG. 4** is a schematic diagram of a two float multiphase-liquid level sensing system.

24

25 [0019] **FIG. 5** is a schematic diagram of a three float multiphase-liquid level sensing system.

26

27 [0020] **FIGS. 6A and 6B** are schematic diagrams of a split stem.

28

**DETAILED DESCRIPTION OF THE INVENTION**1  
2  
3  
4  
5  
6  
7  
8  
9  
10  
11  
12  
13  
14  
15  
16  
17  
18  
19  
20  
21  
22  
23  
24  
25  
26  
27  
28  
29  
30  
31

**[0021]** A preferred embodiment of the invention is now described in detail. Referring to the drawings, like numbers indicate like parts throughout the views. As used in the description herein and throughout the claims, the following terms take the meanings explicitly associated herein, unless the context clearly dictates otherwise: the meaning of “a,” “an,” and “the” includes plural reference, the meaning of “in” includes “in” and “on.” Also, as used herein, “phase” refers to the relationship of one liquid to another liquid based on their respective specific gravities.

**[0022]** As shown in FIG. 1, one embodiment includes a multiphase-liquid level sensing system **100** for sensing a layer depth and thickness of a liquid of a first phase that floats on a liquid of a different second phase. The sensing system **100** includes a sensor unit **110** that is remotely coupled to an electronics enclosure **122** (such as a digital computer or an analog computing system) via a communications channel **120** (which, in one embodiment, includes a shielded composite electrical cable). The sensor unit **110** includes an elongated composite stem **112** that has a top end **117** and an opposite bottom end **115**. A top retainer **118** is disposed adjacent the top end **117** and a bottom retainer **116** disposed adjacent the bottom end **115**. The elongated stem **112** defines an elongated cavity **113** into which is placed a level sensor **111**, such as a sequence of spaced apart reed switches. Magnetostrictive, other magnetic field dependant technologies and other non-magnetic technologies can be used as an alternative to reed-switches.

**[0023]** A first float **130** is disposed coaxially around the elongated stem **112**. The float includes an annular flotation member **132** that has a top end and an opposite bottom end. Affixed to either the top end or the bottom end is an element **134** that exhibits a property that is sensible by the level sensor **111**. For example the element **134** could be a magnet that generates a magnetic field. When the level sensor **111** includes a series of reed switches, the magnetic field would cause the reed switch closest to the magnet to close while all of the other reed switches would remain open (or vice versa). Since the position of each of the reed switches is know, changing the state of the reed switch that is in the state that indicates juxtaposition with the magnet would indicate the level of the float **130** relative to the elongated stem **112**. The



1 floatation member **132** and the element **134** together cause the float **130** to have a buoyancy that  
2 would cause it to float at an interface of two different liquids. For example, if the float **130** had a  
3 negative buoyancy relative to a liquid of a first phase and a positive buoyancy relative to a liquid  
4 of a second phase, then the float **130** would float at the interface between the two liquids, and the  
5 position of the float **130** would indicate the level of the interface.

6  
7 **[0024]** When the float **130** is used in conjunction with reed-switch based technology, a series  
8 of multi-tiered sequential reed switches may be positioned within the hermitically sealed  
9 transmitter housed in the non-magnetic composite stem **112**. The switches are connected via a  
10 shielded composite cable **120** to the electronics enclosure **122**. A regulated direct current (DC) is  
11 applied to a voltage divider which extends the full length of the transmitter. As the float **130**  
12 with a magnetic sleeve **134** moves up and down, the corresponding switches are magnetically  
13 actuated to open or close in sequence thus tapping off the next higher or lower voltage. It is  
14 therefore possible to locate continually the position of the float **130** by measuring the voltage  
15 which is transmitted to the electronics enclosure **122**.

16  
17 **[0025]** The composite stem houses both a sealed transmitter composed of a series of reed  
18 switches used for measuring the position of the float as well as a set of wires in a shielded  
19 composite cable that convey the pressure readings from the transducer. A shield will separate  
20 any noise between the transducer and the reed switches.

21  
22 **[0026]** An overburden sensor **114** extends downwardly from the bottom end **115** of the stem  
23 **112**. The overburden sensor **114** could be, for example, a pressure transducer and is capable of  
24 sense a property that indicates a total liquid thickness of liquid above the overburden sensor **114**.  
25 For example, if the overburden sensor **114** is a pressure transducer, then the pressure it senses  
26 would be directly proportional to the amount of liquid above the pressure transducer. One  
27 example of a suitable pressure transducer is a submersible pressure transducer, Model No. PXD.  
28 261, available from Insitu Inc. 221 East Lincoln Avenue, Ft. Collins, CO 80524.

29

1 [0027] The electronics enclosure **122**, which includes a computational circuit (such as a  
2 digital computer or an analog computer), calculates the layer thickness of the liquid above the  
3 float **130** based on a signal from the level sensor **111** and the overburden sensor **114**.

4  
5 [0028] A depth indicator can indicate a depth of the overburden sensor relative to a  
6 predetermined point. The depth indicator could simply be a device that measures the length of  
7 the cable **120** that has been played out in lowering the sensor unit **110**. With a knowledge of the  
8 depth of the sensor unit **110**, the sensing system **100** can determine both the layer depth and layer  
9 thickness of the liquid above the float **130**.

10  
11 [0029] The sensing system **100** can be used to detect layer depths of different liquid phases  
12 in such things as tanks, sumps, wells, reservoirs, lakes, rivers and many other things that store  
13 liquids of more than one liquid phase together. For example, as shown in FIG. 1B, the sensing  
14 system **100** may be used to detect the layer depth and thickness of a LNAPL layer **220** (such as  
15 an oil layer) that is floating on a water layer **210** in a well **200**. The sensing system **100** can be  
16 used in concert with a pump **202** to insure that the pump intake **204** does not extend into the  
17 water layer **210**. The sensing system **100** allows real-time monitoring of LNAPL layer **220** depth  
18 as the LNAPL is being pumped out. Since the water layer **210** level may rise as the LNAPL is  
19 being pumped out due to the removal of the overburdening weight of the LNAPL, the sensing  
20 system **100** can prevent over pumping of the well **200**. This can be especially important because  
21 if the water layer **210** extends into the pores from which LNAPL flows into the well **200**, the  
22 water can block the pores, thereby reducing the capacity of the well.

23  
24 [0030] As shown in FIG. 1C, certain pumping systems **234** do not accommodate placement  
25 of the sensing system **100** in the same well **232** that is being pumped. However, the sensing  
26 system **100** can still monitor the layer thickness and depth in the well **232** by being placed in an  
27 adjacent well **230**.

28  
29 [0031] Calculation of the layer thicknesses is demonstrated as follows, with referenced to  
30 FIG. 2. At predetermined intervals, the transducer **114** measures the differential pressure (“PA”)  
31 (apparent pressure) exerted by the fluids **210** and **220** present above the transducer **114**. This

1 data is used to compute the apparent height (“HA”) of the fluids **210** and **220**. Since the  
 2 transducer is unable to distinguish between the multi-phase liquids present above the transducer,  
 3 the true height of the multiphase fluid “H” must be determined by further computations.

4  
 5 **[0032]** The data from the level sensor **111** and the transducer **114** is further processed to  
 6 calculate elevations and thicknesses of multiphase liquids. The distance between the float switch  
 7 and the transducer establishes the true height “ $h_w$ ” of water above the transducer **114**. The  
 8 LNAPL layer height (“ $h_L$ ”) above the water layer is calculated as follows: First, the pressure  
 9 exerted by the water (PW) above the transducer is deducted from  $h_w$  as follows. Given that  
 10 pressure of 1 psi = 2.307 feet of water,  $PW = h_w / 2.307$ . The additional pressure exerted by the  
 11 LNAPL (PL) is  $PL = PA - PW$ . Then, the thickness of LNAPL layer **220** floating on the water  
 12 surface is  $h_L = PL * 2.307 * SGL$ , where SGL = specific gravity of the LNAPL. (This can be  
 13 determined by sampling the LNAPL and determining its specific gravity using well know  
 14 methods.) Then, the true height of the multiphase liquid above the transducer,  $H = h_L + h_w$ . The  
 15 height “H” can be referenced to the transducer elevation, an arbitrary elevation, or an elevation  
 16 referenced to mean sea level (MSL), or any other reference elevations to compute the true datum  
 17 of the liquid level measured by the transducer.

18  
 19 **[0033]** In certain embodiments, the sensing system **100** may be used to measure the thickness  
 20 of a water layer above a DNAPL layer. In such an embodiment, as shown in FIG. 3, a float **330**  
 21 that is negatively buoyant in water and positively buoyant in DNAPL is used.

22  
 23 **[0034]** The distance between the float switch and the transducer establishes the true height  
 24 “ $h_D$ ” of DNAPL above the transducer. The height “ $h_w$ ” of the water above the water-DNAPL  
 25 interface is calculated as follows: First, pressure at 1 psi = 2.307 feet of water and, therefore,  
 26  $PW = h_W / 2.307$ . The pressure exerted by the DNAPL layer is first computed according to the  
 27 following formula:  $PD = SGD \times (h_D / 2.307)$ , where SGD=Specific gravity of the DNAPL. The  
 28 additional pressure exerted by the water above the water-DNAPL interface is computed as  
 29 follows:  $PW = PA - PD$ . The thickness of water above the water-DNAPL interface is computed  
 30 as follows:  $h_w = PW * 2.307$ . The true height of the multiphase liquid above the transducer,  
 31  $H = h_L + h_w$ . As mentioned above, the height “H” can be referenced to the transducer elevation, an

1 arbitrary elevation, or an elevation referenced to mean sea level (MSL), or any other reference  
2 elevations to compute the true datum of the liquid level measured by the transducer.

3  
4 **[0035]** As shown in FIG. 4, a second float **430** may be employed to enable the system to  
5 measure relatively thin layers with a high level of precision. This system employs a first float  
6 **430** and a second float **440**. The first float **430** can be cup-shaped and define an open portion  
7 **432** that is complementary in shape to the second float **440**. The first float **430** defines at least  
8 one passage **434** passing downwardly therethrough so as to allow liquid to drain out of the open  
9 portion **432**. Thus, as the LNAPL layer thins, the second float **440** can fit into the open portion  
10 **432** so as to give a precise indication of the thickness of the LNAPL layer. The passage **434** (or  
11 passages) may be embodied with perforations or as a screen. Also, the passage **434** can be either  
12 on the bottom as shown, or extending radially from the side of the float **430**. The passage **434**  
13 allows the second float **440** to seat into the first float **430** without entrapping liquid within the  
14 open portion **432**.

15  
16 **[0036]** A three float embodiment, as shown in FIG. 5, allows precise measurement of the  
17 thickness of two layers in a multi-layer environment (for example one in which a water layer is  
18 above a DNAPL layer and a LNAPL layer is above the water layer). This embodiment adds a  
19 third float **330** having a buoyancy that is negative in water and positive in DNAPL. Addition of  
20 a transducer (not shown) at the bottom of the stem **112** would allow the layer thickness  
21 monitoring of an additional layer above the LNAPL layer.

22  
23 **[0037]** The range of measurement for all of the versions discussed above can be extended by  
24 adding additional lengths of stem. As shown in FIGS. 6A and 6B, the stem **112** can be  
25 lengthened as much as desired with a split stem adapter **900**, which includes a first section **912**  
26 and a complimentary second section **914**. Standard temperature, barometric correction, and  
27 clock functions can be added to the stem adapter **900** as needed. Apart from traditional line  
28 power, the system **100** can be powered by various sources of electricity. Also, a small battery  
29 power supply (not shown) can be integrated into the stem **112** to store data for retrieval at a later  
30 time. Direct-read cable can be utilized to transmit real time data to a remote receiver or

1 wirelessly transmitted to a remote receiver. The stem **112** can be composed of either solid or  
2 flex pipe.

3  
4 **[0038]** Since numerous configurations with different sensing devices are possible, many  
5 different mechanical constructions and arrangements of the apparatus are possible. The system  
6 may be provided with a protective sleeve to prevent entanglement with other devices that may be  
7 deployed adjacent to the device. The system provides continuous real time observations of the  
8 liquid levels and the thicknesses at predetermined intervals.

9  
10 **[0039]** The above described embodiments, while including the preferred embodiment and the  
11 best mode of the invention known to the inventor at the time of filing, are given as illustrative  
12 examples only. It will be readily appreciated that many deviations may be made from the  
13 specific embodiments disclosed in this specification without departing from the spirit and scope  
14 of the invention. Accordingly, the scope of the invention is to be determined by the claims  
15 below rather than being limited to the specifically described embodiments above.

**CLAIMS**

What is claimed is:

1. A multiphase-liquid level sensing system for sensing a layer depth and thickness of a liquid of a first phase that floats on a liquid of a different second phase, comprising:
  - a. an elongated stem having a top end and an opposite bottom end, a top retainer disposed adjacent the top end and a bottom retainer disposed adjacent the bottom end, the elongated stem defining an elongated cavity therein;
  - b. a first float disposed coaxially around the elongated stem, a portion of the first float exhibiting a sensible property, the first float having a negative buoyancy relative to the liquid of the first phase and a positive buoyancy relative to the liquid of the second phase;
  - c. a level sensor disposed within the cavity defined by the elongated stem that senses the sensible property of the portion of the first float, the level sensor configured to indicate a second phase liquid distance from the first float to the bottom end of the stem based on where the sensible property is sensed on the level sensor;
  - d. an overburden sensor extending downwardly from the bottom end of the stem, the overburden sensor configured to sense a property indicative of a total liquid thickness of the liquid of the first phase and the liquid of the second phase above the overburden sensor; and
  - e. a computational circuit, responsive to a first signal from the level sensor, a second signal from the overburden sensor, that is configured to calculate a layer thickness of the liquid of the first phase wherein the layer thickness of the liquid of the first phase equals a pressure exerted on the overburden sensor by the liquid of the first phase on the overburden sensor times a pressure increase per unit depth of the liquid of the second phase times a specific gravity of the liquid of the first phase.
  
2. The multiphase-liquid level sensing system of claim 1, wherein the computational circuit is configured to calculate the pressure exerted on the overburden sensor by the liquid of the first phase as being equal to a pressure sensed by the overburden sensor minus a

pressure exerted by the liquid of the second phase above the overburden sensor, wherein the pressure exerted by the liquid of the second phase above the overburden sensor is calculated as being equal to a distance between the overburden sensor and the first float divided by the pressure increase per unit depth of the liquid of the second phase.

3. The multiphase-liquid level sensing system of claim 1, wherein the overburden sensor comprises a pressure transducer.
4. The multiphase-liquid level sensing system of claim 1, wherein the level sensor comprises a plurality of spaced-apart reed switches, each reed switch being capable of switching from a first state to a different second state when subjected to the sensible property of the first float.
5. The multiphase-liquid level sensing system of claim 1, wherein the sensible property of the first float comprises a magnetic field.
6. The multiphase-liquid level sensing system of claim 5, wherein the first float comprises:
  - a. an annular floatation member having a top end and an opposite bottom end; and
  - b. a magnet that is affixed to the annular floatation member.
7. The multiphase-liquid level sensing system of claim 6, wherein the magnet is affixed to the bottom end of the first floatation member.
8. The multiphase-liquid level sensing system of claim 6, wherein the magnet is affixed to the top end of the first floatation member.
9. The multiphase-liquid level sensing system of claim 1, further comprising a second float disposed coaxially around the elongated stem below the first float, a portion of the second float exhibiting the sensible property, the second float having a positive buoyancy relative to the liquid of the first phase and a negative buoyancy relative to a liquid of a third phase.

10. The multiphase-liquid level sensing system of claim 9, wherein the first float comprises:
  - a. a cup-shaped floatation member having a top end and an opposite bottom end, the cup-shaped floatation member defining an open portion that is complementary in shape to the second float; and
  - b. a magnet that is affixed to the cup-shaped floatation member.
11. The multiphase-liquid level sensing system of claim 10, wherein the first float defines at least one passage passing downwardly therethrough so as to allow liquid to drain out of the open portion.
12. The multiphase-liquid level sensing system of claim 1, wherein the liquid of the first phase comprises a liquid having a specific gravity that is less than 1 and wherein the liquid of the second phase comprises a liquid having a specific gravity that is not less than 1.
13. The multiphase-liquid level sensing system of claim 12, wherein the liquid of the first phase comprises a light non-aqueous phase liquid and wherein the liquid of the second phase comprises water.
14. The multiphase-liquid level sensing system of claim 1, wherein the liquid of the first phase comprises a liquid having a specific gravity that is not greater than 1 and the liquid of the second phase comprises a liquid having a specific gravity that is greater than 1.
15. The multiphase-liquid level sensing system of claim 14, wherein the liquid of the first phase comprises water and wherein the liquid of the second phase comprises a dense non-aqueous phase liquid.
16. The multiphase-liquid level sensing system of claim 1, further comprising a second float disposed coaxially around the elongated stem below the first float, a portion of the second float exhibiting the sensible property, the second float having a negative buoyancy



relative to the liquid of the first phase and a positive buoyancy relative to a liquid of a third phase.

17. The multiphase-liquid level sensing system of claim 16, wherein the liquid of the third phase comprises a dense non-aqueous phase liquid.
18. A multiphase-liquid level sensing system for sensing a layer depth and thickness of a liquid of a first phase that floats on a liquid of a different second phase, comprising:
  - a. an elongated stem having a top end and an opposite bottom end, a top retainer disposed adjacent the top end and a bottom retainer disposed adjacent the bottom end, the elongated stem defining an elongated cavity therein;
  - b. a first float disposed coaxially around the elongated stem, the first float including an annular floatation member having a top end and an opposite bottom end and a magnet that is affixed to the annular floatation member, the magnet configured to generate a sensible magnetic field, the first float having a negative buoyancy relative to the liquid of the first phase and a positive buoyancy relative to the liquid of the second phase;
  - c. a plurality of spaced-apart reed switches disposed within the cavity defined by the elongated stem the level sensor, each reed switch being capable of switching from a first state to a different second state when subjected to a magnetic field so as to indicate a position of the second float, thereby indicating a second phase liquid distance from the first float to the bottom end of the stem;
  - d. a pressure transducer extending downwardly from the bottom end of the stem, the pressure transducer configured to sense a pressure indicative of a total liquid thickness of the liquid of the first phase and the liquid of the second phase above the pressure transducer;
  - e. a depth indicator that indicates a depth of the pressure transducer relative to a predetermined point; and
  - f. a computational circuit, responsive to a first signal from the level sensor, a second signal from the pressure transducer and the depth of the pressure transducer, that calculates a layer depth and thickness of the liquid of the first phase, wherein the

layer thickness of the liquid of the first phase equals a pressure exerted on the pressure transducer by the liquid of the first phase on the pressure transducer times a pressure increase per unit depth of the liquid of the second phase times a specific gravity of the liquid of the first phase and wherein the computational circuit is configured to calculate the pressure exerted on the pressure transducer by the liquid of the first phase as being equal to a pressure sensed by the pressure transducer minus a pressure exerted by the liquid of the second phase above the pressure transducer, wherein the pressure exerted by the liquid of the second phase above the pressure transducer is calculated as being equal to a distance between the pressure transducer and the first float divided by the pressure increase per unit depth of the liquid of the second phase.

19. The multiphase-liquid level sensing system of claim 18, wherein the magnet is affixed to the bottom of the first floatation member.
20. The multiphase-liquid level sensing system of claim 18, wherein the magnet is affixed to the top end of the first floatation member.
21. The multiphase-liquid level sensing system of claim 18, further comprising a second float disposed coaxially around the elongated stem above the first float, a portion of the second float exhibiting the sensible property, the second float having a positive buoyancy relative to the liquid of the first phase and a negative buoyancy relative to a liquid of a third phase.
22. The multiphase-liquid level sensing system of claim 18, further comprising a second float disposed coaxially around the elongated stem below the first float, a portion of the second float exhibiting the sensible property, the second float having a negative buoyancy relative to both the liquid of the first phase and to the liquid of the second phase, the second float also having a positive buoyancy relative to a liquid of a third phase.

23. The multiphase-liquid level sensing system of claim 18, wherein the liquid of the first phase comprises a light non-aqueous phase liquid and wherein the liquid of the second phase comprises water.
24. The multiphase-liquid level sensing system of claim 18, wherein the liquid of the first phase comprises a selected one of either water or a light non-aqueous phase liquid and wherein the liquid of the second phase comprises a dense non-aqueous phase liquid.
25. The multiphase-liquid level sensing system of claim 18, wherein the liquid of a first phase comprises water and wherein the liquid of the second phase comprises a dense non-aqueous phase liquid.

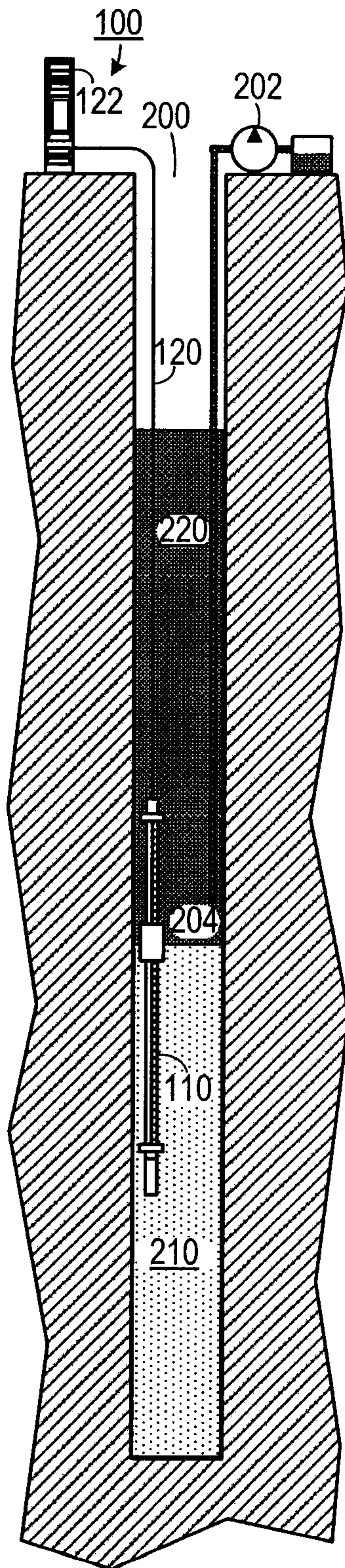
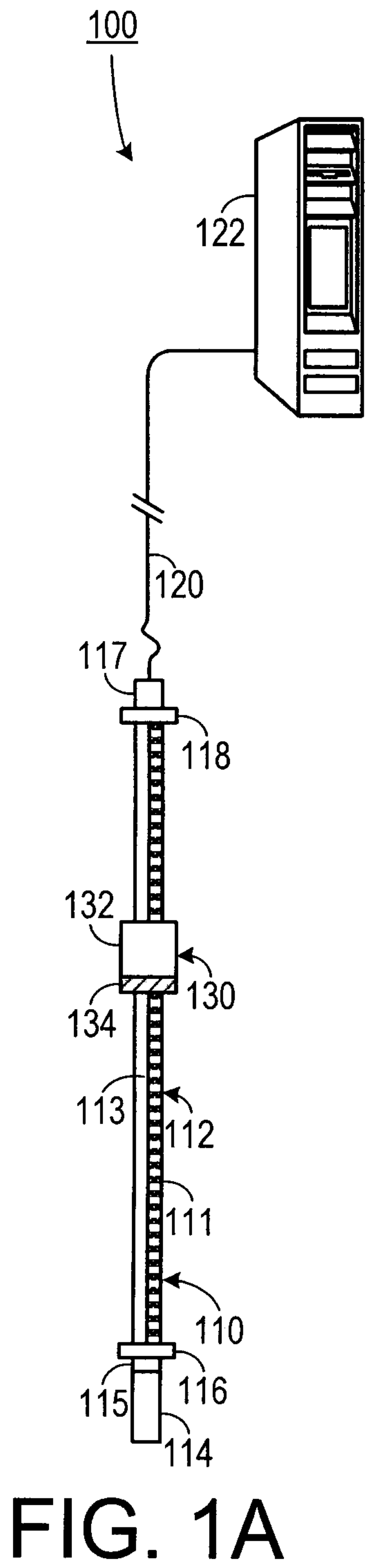

FIG. 1B

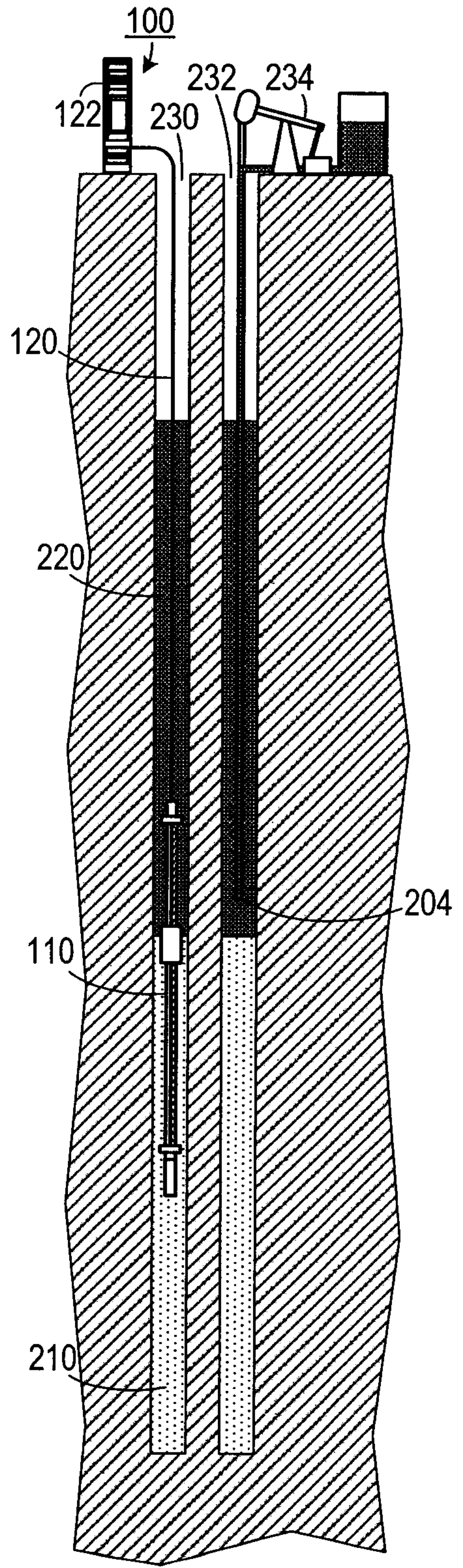

FIG. 1C

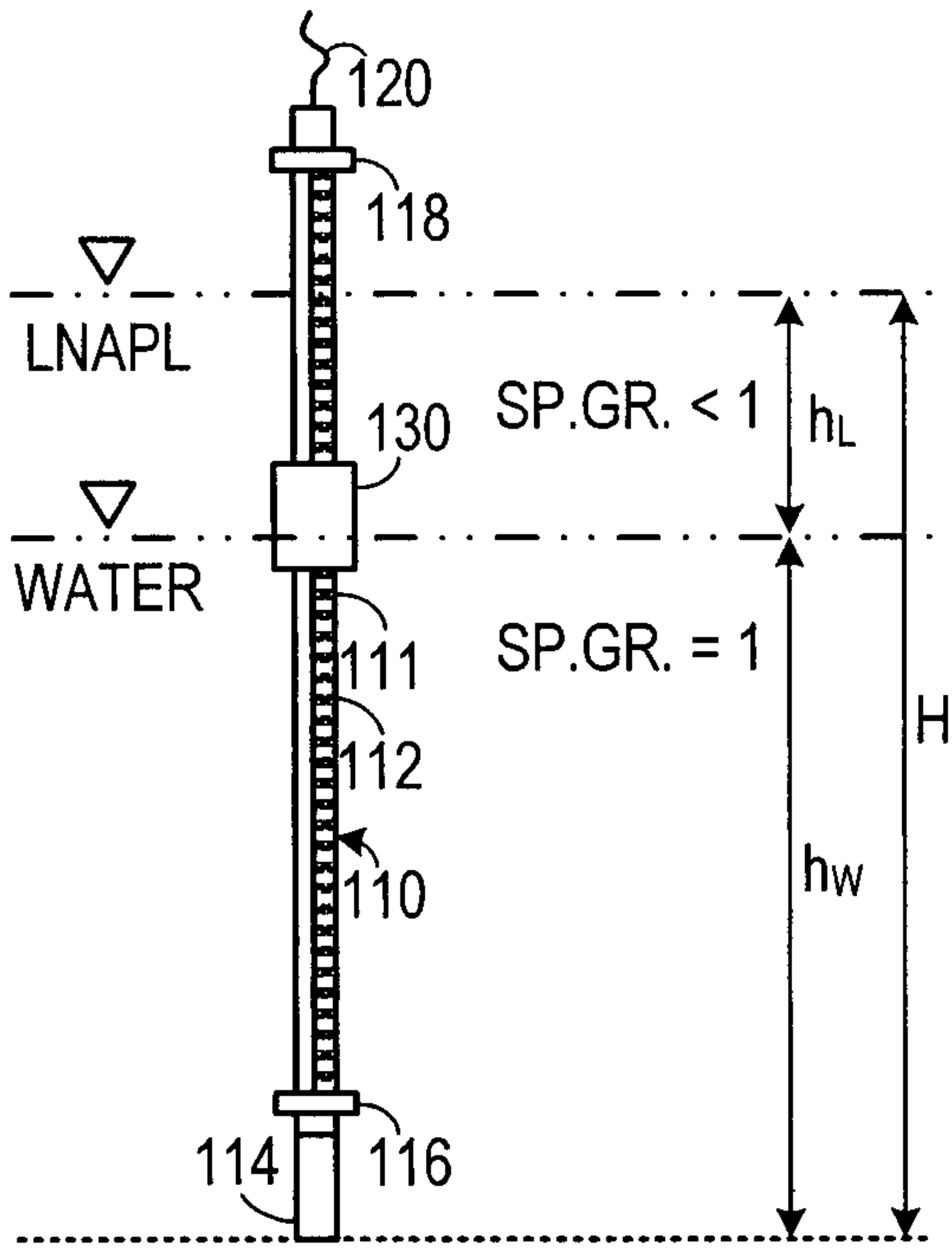

FIG. 2

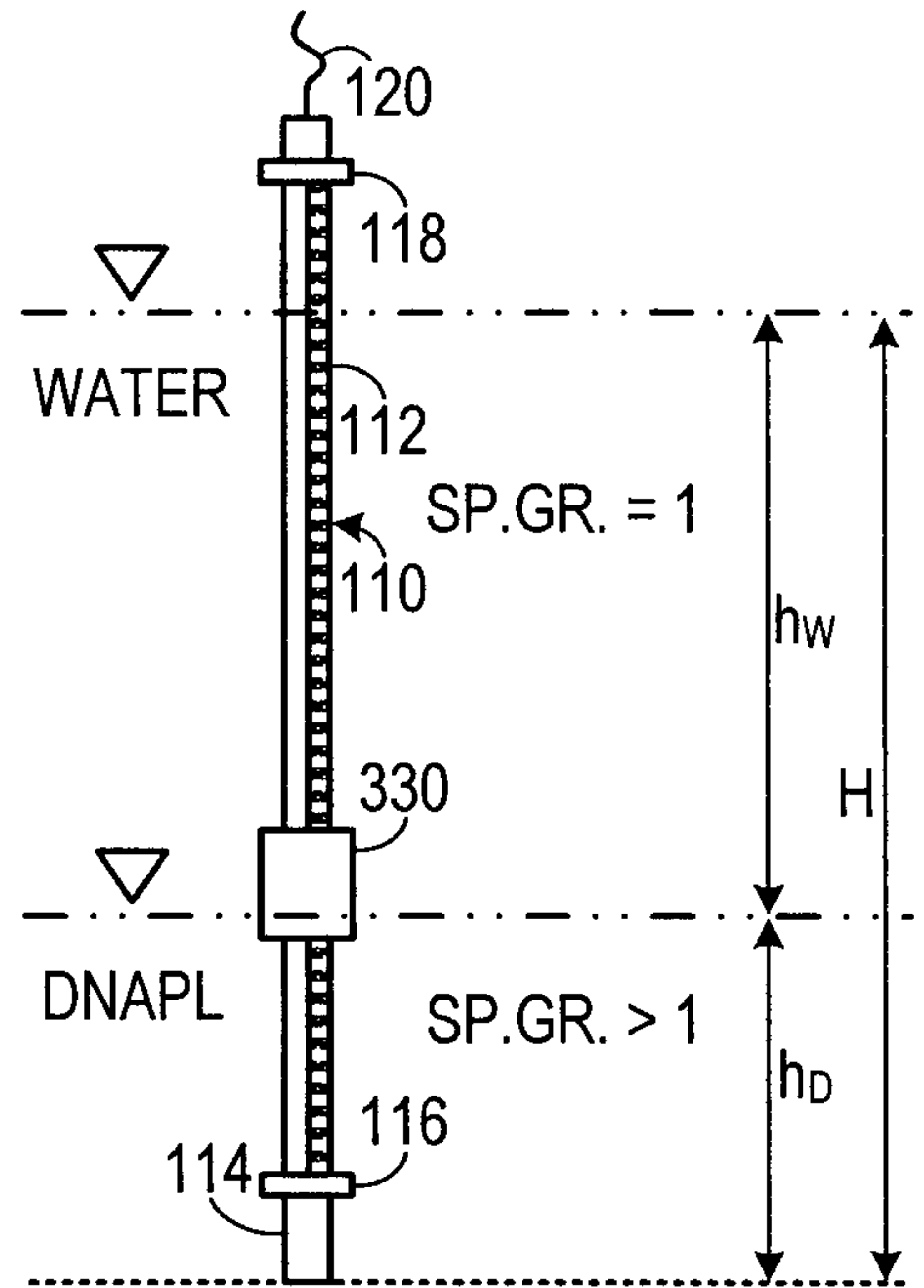

FIG. 3

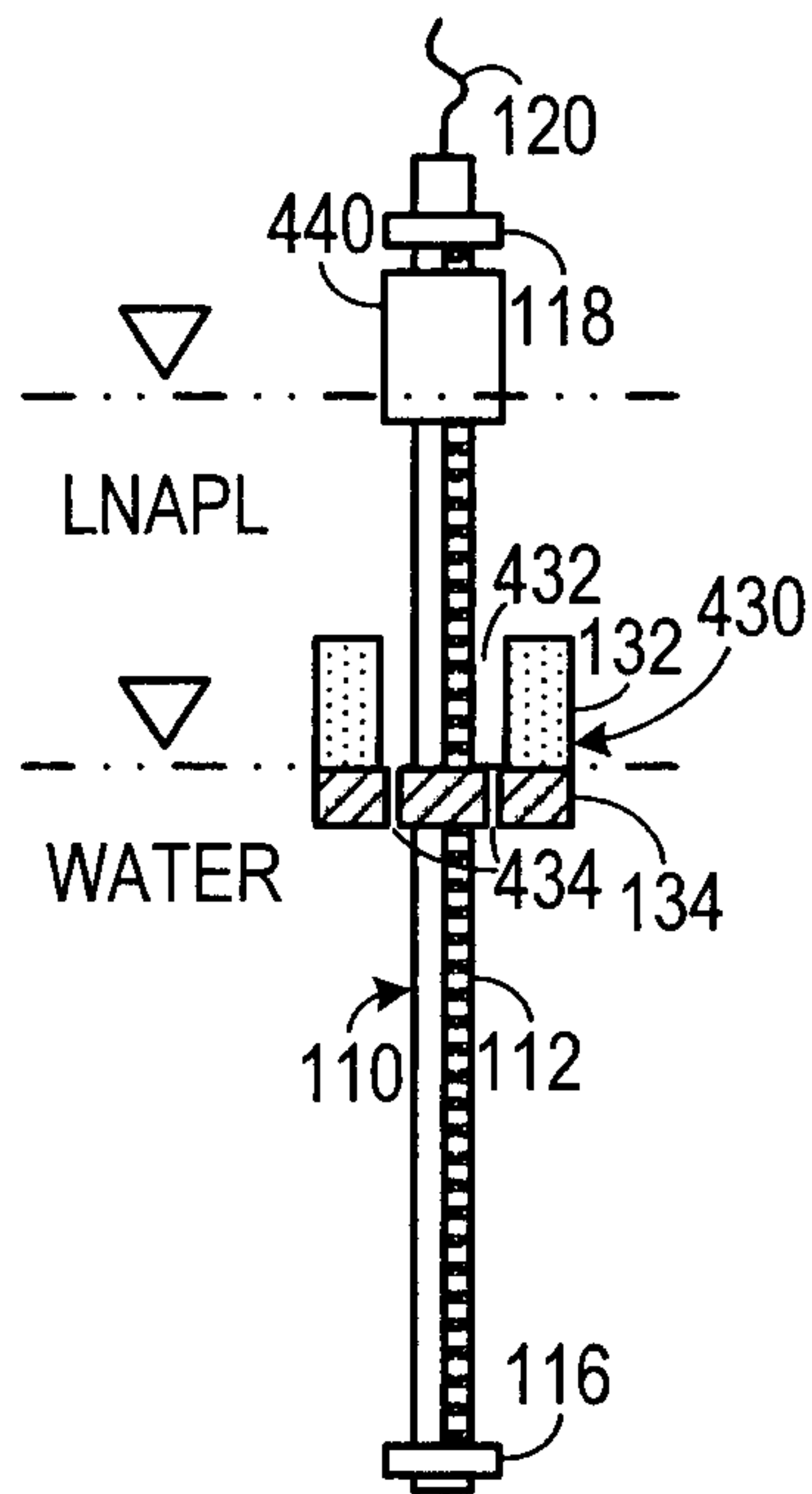

FIG. 4

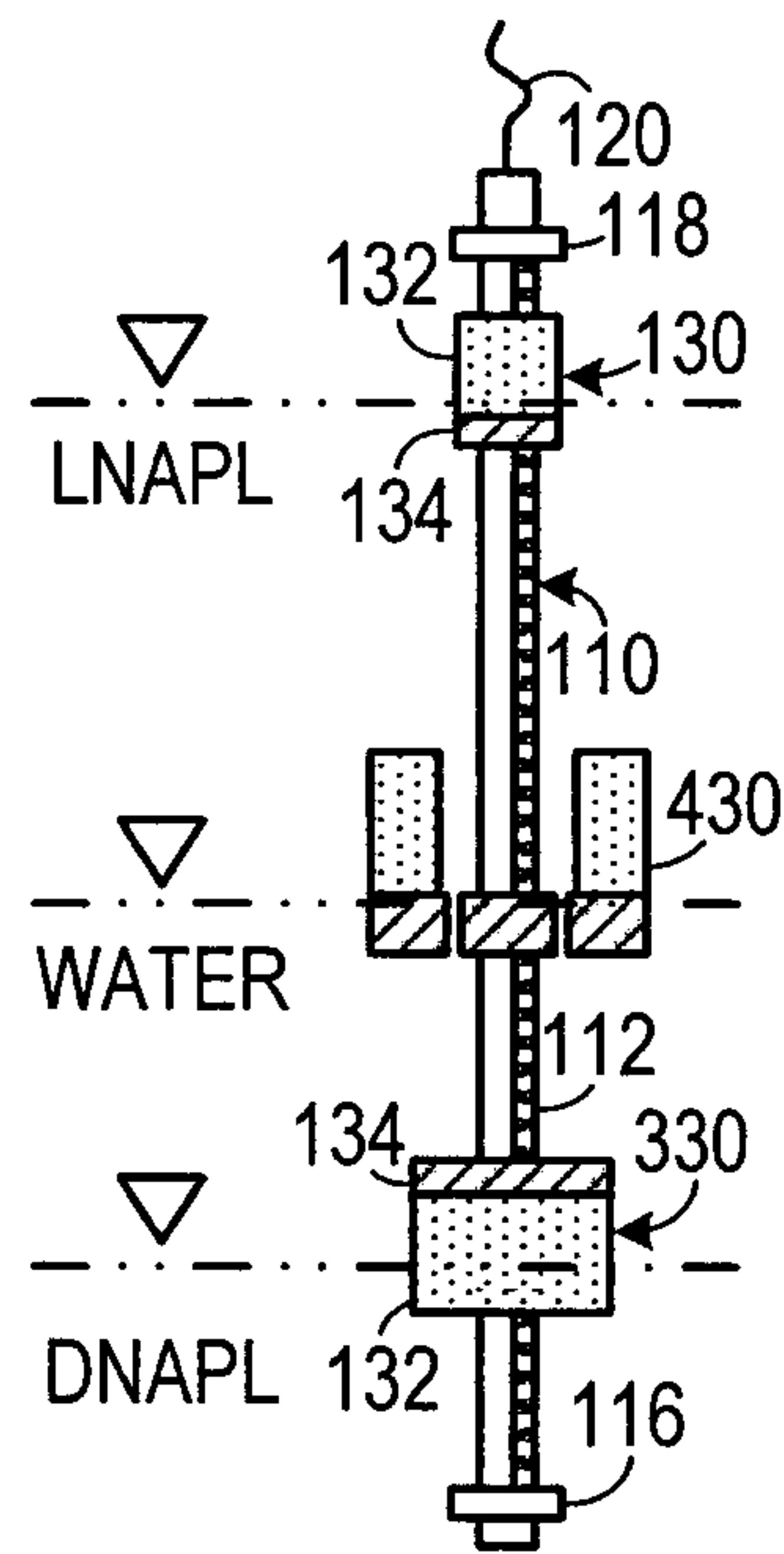
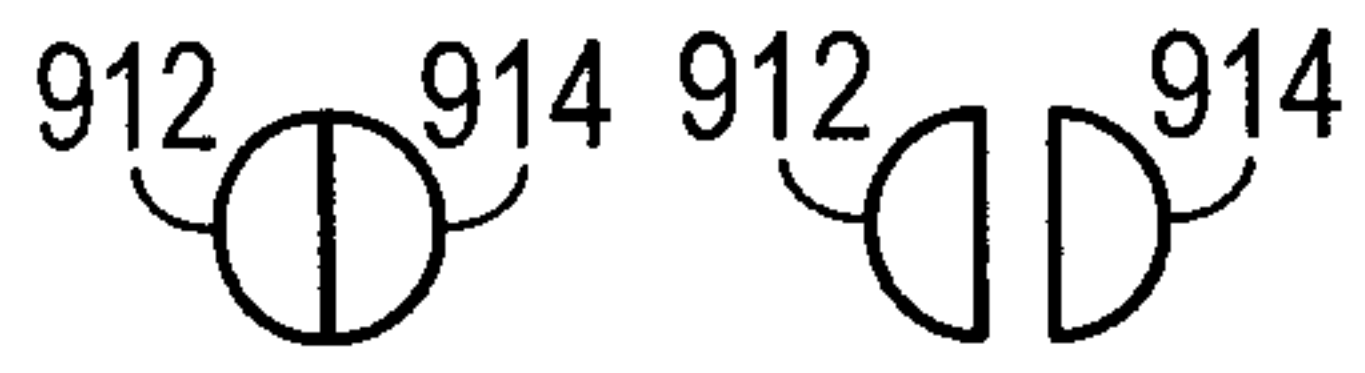
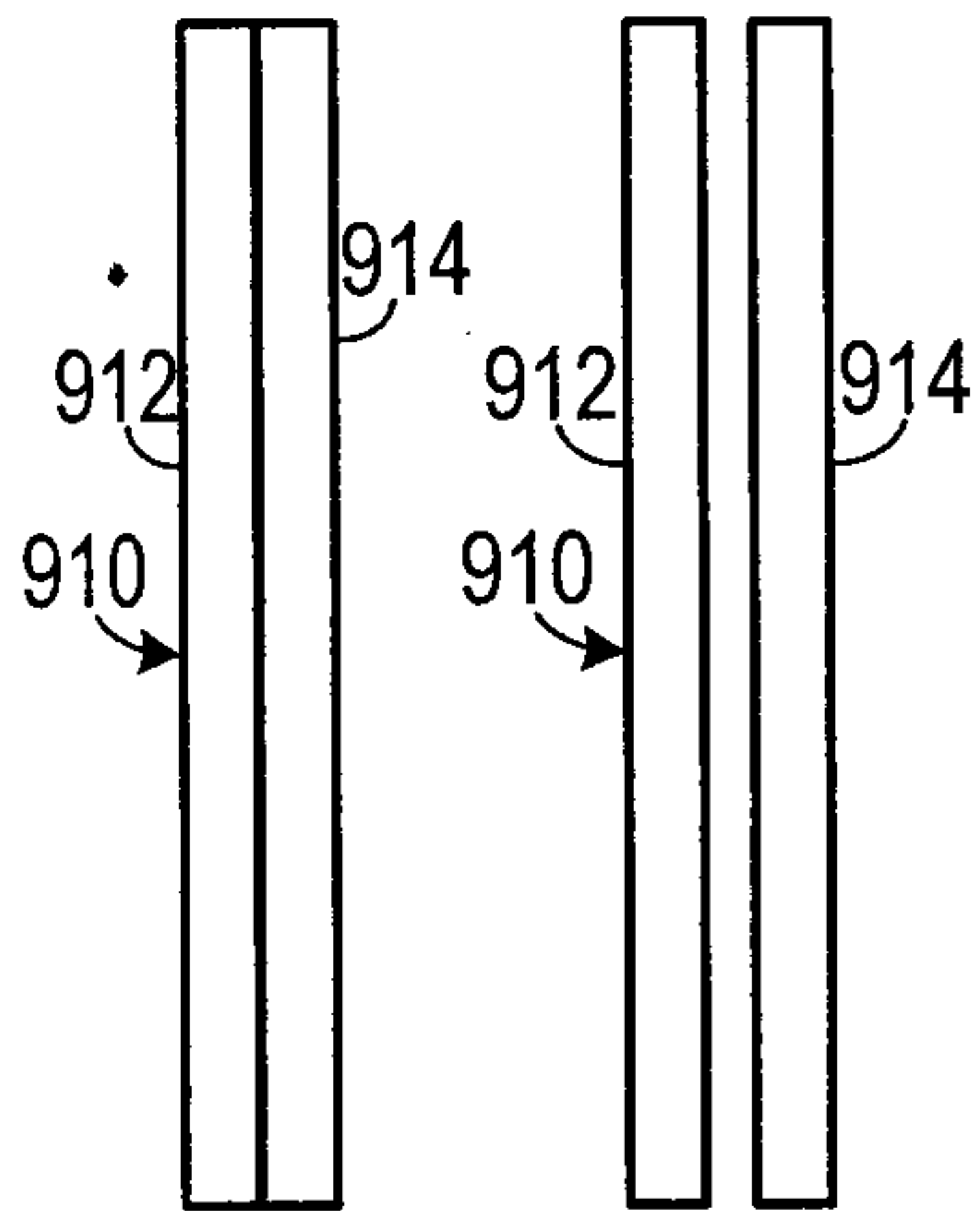

FIG. 5



**FIG. 6B**



**FIG. 6A**

