



(72) VEYLUPEK, ROBERT J., US

(71) VEYLUPEK, ROBERT J., US

(51) Int.Cl.⁷ A43C 11/00

(54) **SYSTEME DE LACAGE DE CHAUSSURE**

(54) **SHOE LACING SYSTEM**

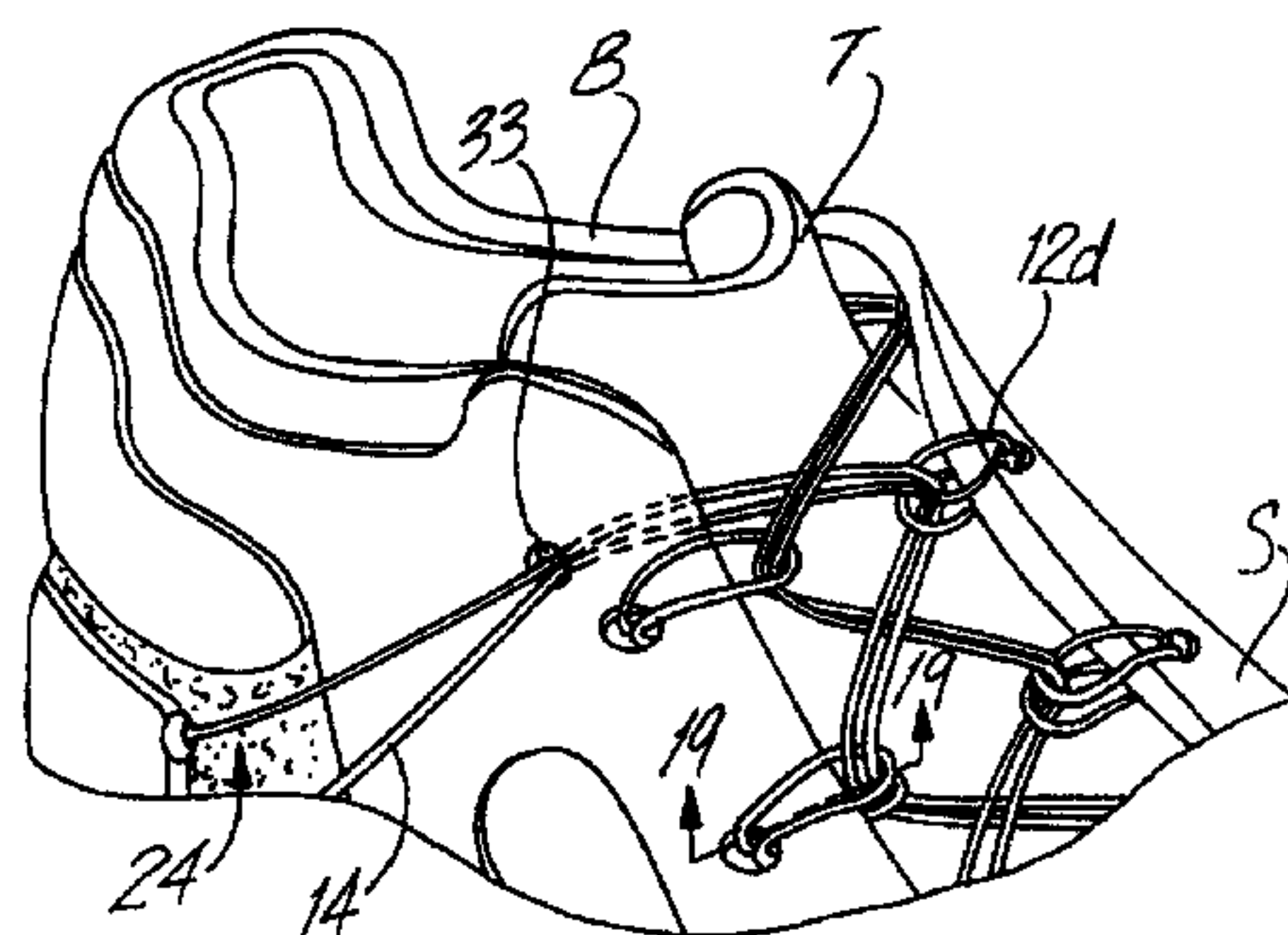

(57) Un système de laçage de chaussure comporte un lacet (14), des éléments d'ancrage (12a) et un mécanisme pour fixer de manière réversible les extrémités du lacet à la chaussure (24). Les éléments d'ancrage (12a) comprennent des guides (22) possédant une première partie destinée à être fixée à un oeillet existant de la chaussure (20), et une deuxième partie dans laquelle et par laquelle le lacet peut se déplacer (22a). Le lacet (14) comporte une double brin de matière possédant une surface extérieure à faible frottement. Une partie médiane du lacet est passée dans les éléments d'ancrage (12a) et entre les deux, des côtés opposés d'une languette (L) de la chaussure. Les extrémités du lacet (14) s'étendent depuis les éléments d'ancrage (12a), à proximité du sommet de la languette (L), le long des côtés opposés de la chaussure jusqu'à l'arrière (A) de la chaussure. Chaque lacet (14) est relié à une patte (52a, 52b) possédant une section en matière à boucles et crochets (24), conçue pour venir en prise avec une section coïncidente située à l'arrière de la chaussure (50).

(57) A shoe lacing system comprises a lace (14), anchor elements (12a), and a mechanism for releasably attaching the ends of the lace to the shoe (24). The anchor elements (12a) comprise guides (22) having a first portion for attachment to an existing eyelet of the shoe (20), and a second portion through which and with respect to which the lace may move (22a). The lace (14) comprises a double-strand of material having a low friction outer surface. A middle portion of the lace is routed through and between the anchor elements (12a) located on opposite sides of a tongue (T) of the shoe. The ends of the lace (14) extend from the anchor elements (12a) near a top of the tongue (T) along opposite sides of the shoe to the rear (R) of the shoe. Each lace (14) is connected to a tab (52a, 52b) having a section of hook or loop material (24) designed for engagement with a mating section of material on the rear of the shoe (50).

PCT

WORLD INTELLECTUAL PROPERTY ORGANIZATION
International Bureau

INTERNATIONAL APPLICATION PUBLISHED UNDER THE PATENT COOPERATION TREATY (PCT)

<p>(51) International Patent Classification ⁶ : A43C 11/00</p>	<p>A1</p>	<p>(11) International Publication Number: WO 99/59440 (43) International Publication Date: 25 November 1999 (25.11.99)</p>
<p>(21) International Application Number: PCT/US98/10466 (22) International Filing Date: 21 May 1998 (21.05.98) (71)(72) Applicant and Inventor: VEYLUPEK, Robert, J. [US/US]; 5250 South Huron Way #13-312, Littleton, CO 80120 (US). (74) Agent: ANDERSON, Philip, J.; Quirk & Tratos, Suite 500 North, 3773 Howard Hughes Parkway, Las Vegas, NV 89109 (US).</p>		<p>(81) Designated States: AU, CA, CN, JP, European patent (AT, BE, CH, CY, DE, DK, ES, FI, FR, GB, GR, IE, IT, LU, MC, NL, PT, SE). Published <i>With international search report.</i></p>
<p>(54) Title: SHOE LACING SYSTEM</p>		
<p>(57) Abstract</p>		
<p>A shoe lacing system comprises a lace (14), anchor elements (12a), and a mechanism for releasably attaching the ends of the lace to the shoe (24). The anchor elements (12a) comprise guides (22) having a first portion for attachment to an existing eyelet of the shoe (20), and a second portion through which and with respect to which the lace may move (22a). The lace (14) comprises a double-strand of material having a low friction outer surface. A middle portion of the lace is routed through and between the anchor elements (12a) located on opposite sides of a tongue (T) of the shoe. The ends of the lace (14) extend from the anchor elements (12a) near a top of the tongue (T) along opposite sides of the shoe to the rear (R) of the shoe. Each lace (14) is connected to a tab (52a, 52b) having a section of hook or loop material (24) designed for engagement with a mating section of material on the rear of the shoe (50).</p>		

SHOE LACING SYSTEMField of the Invention

The present invention generally relates to shoes and,
5 more particularly, to a shoe lacing system for securing
the upper body of a shoe over a wearer's foot.

Background of the Invention

Traditionally, a wearer secures a shoe over his foot
by means of a lace which is threaded in a criss-cross
10 fashion between lace eyelets in the body of the shoe. The
eyelets are arranged in parallel rows on opposite sides of
the body of the shoe separated by a central slit overlying
a tongue of the shoe. The wearer pulls on free ends of
the lace, which in turn pulls the rows of lace eyelets
15 toward one another, thereby securing the upper body of the
shoe tightly over the wearer's foot.

Often, friction between the lace and the eyelets
prevents the wearer from pulling the lace throughout its
length, so that the lace is not evenly tightened along its
20 length. In order to achieve a more secure fit, the wearer
must often adjust individual sections of the lace
extending between pairs of opposing eyelets.

Once the wearer properly tightens the lace, the
wearer ties the opposite ends of the lace together in a
25 knot to prevent loosening of the lace, which would
otherwise allow the rows of lace eyelets to move away from
one another. This process takes time, and in sports such
as triathlons and duathlons where competitors change shoes
during the race, the time it takes to secure a pair of

shoes as described above represents a significant disadvantage.

Shoe lacing arrangements have been proposed in the prior art that are modifications of the above-described traditional arrangement for securing the upper body of a shoe over a wearer's foot. In these arrangements, the lace is typically routed in the traditional criss-cross manner between eyelets, but then after tightening of the lace, the free ends thereof are secured to the upper body of the shoe without the need for tying a knot. Examples of such arrangements are disclosed in U.S. Pat. No. 5,158,428 to Gessner et al. and U.S. Pat. No. 5,349,764 to Posner.

The Gessner et al. patent discloses a shoe lacing arrangement in which a clamp is provided on the upper body of the shoe through which the end of a lace may be routed. The lace may be pulled lengthwise through the clamp in one direction, but when pulled lengthwise in the opposite direction, angled grooves on the sides of the channel direct the lace towards the center of the clamp where it is further locked and retained. Thus, the free ends of a lace may be routed through a pair of these clamps secured to opposite sides of a shoe rather than tying the ends of the lace together.

The Posner patent discloses a shoe lacing arrangement in which a preformed channel is formed on both sides of the ankle portion of a shoe. On both sides of the channel, there is a diagonal groove which extends around the back of the shoe to a horizontal groove on the

opposite side. A first portion of a fastening material, such as hook or loop material, is disposed in the horizontal groove. After tightening of the lace, its free ends are threaded through opposite guides, run along
5 respective diagonal grooves around the back of the shoe and into the horizontal grooves where mating ends of the lace having complementary second portions of the fastening material are fastened to the first portion of the fastening material to secure the shoe to the wearer's foot
10 without the need for tying a knot.

While both the Gessner et al. and Posner shoe lacing arrangements eliminate the need for tying the free ends of the lace together, they fail to address the time-consuming task of properly tightening the lace.

15 Summary of the Invention

The present invention is a shoe lacing system designed to satisfy the aforementioned needs by avoiding the drawbacks of the prior art without introducing other drawbacks. The lacing system of the present invention
20 preferably comprises: (a) a plurality of anchor elements configured for mounting to the eyelets of a shoe; (b) a lace in the form of at least one elongate inelastic flexible element having a low friction outer surface, the lace having a middle section and two ends; and (c) means
25 for releasably fastening or engaging the ends of the lace to a rear end of the shoe.

The lace comprises a flexible, elongate element of strong material having at least an exterior surface which

has a low friction coefficient. Preferably, the lace comprises a section of line or similar material.

The anchor elements may have a variety of configurations. In a first form, the elements each have
5 a first section for engagement with an existing eyelet and a second section for passage of the lace therethrough. In a second form, the anchor elements comprise hollow tubular guides which completely eliminate the need for eyelets. In either case, the anchor elements are mounted on
10 opposite sides of the tongue on the shoe, and are designed for low-friction engagement with the lace, whereby the lace may move freely with respect to each anchor element.

The lace includes a middle section which the wearer routes between the anchor elements. In particular, the
15 wearer preferably laces the shoe in a normal lacing arrangement by routing the lace between the anchors near the front end of the shoe to the elements located near the top of the tongue.

After routing through the anchor elements, the wearer
20 extends the opposite ends of the lace along opposite sides of the shoe to a rear end thereof. Preferably, the laces extend from opposite sides of the inside of the shoe adjacent the tongue through passages in the body of the shoe to the outer surface of the shoe, and then around
25 opposite sides of the shoe to the rear thereof. In another embodiment, the ends of the laces are routed through tubular guides from the tongue area to the rear of the shoe, so as not to be exposed on the outer surface of the shoe.

In a first form, the means for releasably engaging the ends of the lace to the shoe comprises a section of hook or loop material located on the outside surface of the rear of the shoe for engagement with a section of material located on a tab connected to each end of the
5 lace.

In another form, the means for releasably engaging comprises a strap connected to the ends of the laces for engagement with a strip on the shoe. The strap includes
10 a section of hook or loop material for mating engagement with a mating section on the strip. In another form, the means comprises a strap connected to the ends of the laces for engagement with a clamp on the shoe. The strap passes between a clamping arm and base. In a first position, the
15 strap moves freely between the arm and base, and in a second position is secured therebetween.

Use of the lacing system of the present invention is as follows. The wearer or shoe manufacturer mounts the anchor elements on the shoe and routes the lace between
20 them and about the shoe as described above. The wearer releases the tabs connected to the ends of the lace from the section of material on the end of the shoe. The wearer loosens the lace and inserts his foot into the shoe. The wearer then tightens the lace to secure the
25 shoe to his foot.

In order to tighten the lace, the user pulls rearwardly on the tabs connected to the ends of the lace. Because the lace and anchor elements have low-friction exterior surfaces, the lace moves freely with respect to

each and every anchor element. In other words, the lace is evenly tightened along its entire length.

Once the lace is sufficiently tight, the wearer secures each tab to the strip located on the rear of the shoe, whereby preventing loosening of the lace.

Further objects, features, and advantages of the present invention over the prior art will become apparent from the detailed description of the drawings which follows, when considered with the attached figures.

10 Description of the Drawings

FIGURE 1 is a perspective view of a shoe employing a first embodiment of a shoe lacing system of the present invention;

15 FIGURE 2 is an enlarged partial perspective view of the shoe lacing system of Figure 1;

FIGURE 3 is a side elevational view of a first configuration of an anchor element of the lacing system of the present invention;

20 FIGURE 4 is a top plan view of the first configuration of the anchor element of Figure 3;

FIGURE 5 is a perspective view of the first configuration of the anchor element of Figure 3;

25 FIGURE 6 is a perspective view of a second configuration of the anchor element of the lacing system of the present invention;

FIGURE 7 is a top plan view of the second configuration of the anchor element of Figure 6 shown in partial cross-section taken at line 7--7;

FIGURE 8 is a perspective view of a third configuration of the anchor element of the lacing system of the present invention;

5 FIGURE 9 is a cross-sectional view of the fourth configuration of the anchor element of Figure 8 shown in cross-section taken at line 9-9;

FIGURE 10 is a perspective view of a first embodiment of a releasable fastening arrangement of the lacing system of the present invention;

10 FIGURE 11a is a top plan view of a first version of a tab of the first embodiment of the releasable fastening arrangement of Figure 10 having patches of hook or loop fastening material thereon;

15 FIGURE 11b is a side view of the first version of the tab illustrated in Figure 10;

FIGURE 12a is a top plan view of a second version of the tab of the first embodiment of the releasable fastening arrangement of Figure 10;

20 FIGURE 12b is a side view of the second version of the tab illustrated in Figure 12;

FIGURE 13 is a top plan view of a shoe with a second embodiment of the shoe lacing system of the present invention having low friction tubular guide means;

25 FIGURE 14 is a side elevational view in partial cross-section showing a second embodiment of the releasable fastening arrangement of the lacing system of the present invention;

FIGURE 15 is a perspective view of a second embodiment releasable fastening arrangement of the present invention;

5 FIGURE 16 is a perspective view of a third embodiment of the releasable fastening arrangement of a lacing system of the present invention;

FIGURE 17 is a boot illustrated with the second embodiment of the shoe lacing system of the present invention having the low friction tubular guide means
10 illustrated in Figure 13;

FIGURE 18 is a partial perspective view of a shoe with a fourth embodiment anchor element;

FIGURE 19 is a cross-sectional side view of an anchor element illustrated in Figure 18 taken along line 19-19 of
15 Figure 18;

FIGURE 20 is a top view of the anchor element illustrated in Figure 19; and

FIGURE 21 is a perspective view of the anchor element illustrated in Figure 19.

20 Detailed Description of the Preferred Embodiment

Referring to the drawings, and particularly to Figures 1 and 2, there is illustrated a first embodiment of a shoe lacing system of the present invention, generally designated 10. The first embodiment of the
25 lacing system 10 shown in Figures 1 and 2 is for use with a shoe S having a plurality of lace eyelets E formed in the upper body B of the shoe S and arranged in a pair of rows thereof along respective opposite sides of the tongue T of the shoe S.

Generally, the shoe lacing system 10 includes a plurality of anchor elements 12a, an elongated lace 14 and releasable fastening means 24. The anchor elements 12a are configured for mounting to the lace eyelets E, thus forming a pair of rows of elements disposed along the rows of the lace eyelets E.

The elongated lace 14 preferably comprises a double strand of durable, strong, flexible and fairly frictionless cord, as described in more detail below. The lace 14 has a middle portion 16 and two end portions 18a,b. The middle portion 16 of the lace extends through the first or front row of anchor elements 12a located near a front end 32a of the tongue T and then in a criss-cross relationship about and between the anchor elements 12a upwardly along the body B of the shoe S a rear end 32b of the tongue T, and then on to the end portions 18a,b located at the rear R of the shoe.

The releasable fastening means 24, described in more detail below, preferably comprises means for releasably fastening the ends 18a,b of the lace 14 to a rear end R of the upper body B of the shoe S (see also Figure 10).

As illustrated, to facilitate the routing of the lace 14 from the rear portion 32b of the tongue T around the shoe S to the rear R thereof, a passage 33 is preferably located through the body B of the shoe S. A wearer may thereby route the lace 14 from the row of anchor elements 12a located nearest the rear end 32b of the tongue T, between the tongue and body B of the shoe S, and out through the passage 33.

As mentioned above, in the first embodiment of the lacing system 10 shown in Figures 1 and 2, lace/shoe anchor means are defined in the form of anchor elements 12a mounted to the respective lace eyelets E. The anchor elements 12a in one row extend from the lace eyelets E toward the anchor elements 12a in the other opposite row and partly over the tongue T of the shoe S. The anchor elements 12a-d may have a variety of different configurations, some of which are best illustrated in Figures 5, 6, 8, and 21.

In all of the different anchor configurations illustrated in Figures 5, 6, 8 and 21, each anchor element 12a-d is similar in that it comprises an attaching portion 20a-d and a guiding portion 22a-d. The attaching portion 20a-d of each anchor element 12a-d is connectable to one of the lace eyelets E. The guiding portion 22a-d of each anchor element 12a-d is fixedly attached to the attaching portion 20a-d such that when the anchor element 12a-d is installed, it preferably extends beyond a corresponding one of the respective opposite sides of the tongue T toward the opposite side of the tongue.

The inside surfaces of the guiding portion 22a-d of each anchor element 12a-d are is designed for smooth passage of the lace 14 therethrough. As such, the inside surfaces of the guiding portion 22a-d are curved, smooth, and low friction. The anchor elements 12a-d, with respect to all embodiments described hereinafter, are made of a smooth, slippery, or low friction material, such as

plastic or metal, for ease of movement of the lace 14 therethrough.

A first configuration of the anchor element 12a-d is illustrated in Figures 1-5. In this configuration, the anchor element 12a is a substantially rigid member 26 preferably made of a high-strength, light-weight plastic or polycarbonate material. The attaching portion 20a of the anchor element 12a preferably comprises a "U"-shaped first hook 28 formed on one of a pair of opposite ends of the member 26. The guiding portion 22 of the anchor element 12a is a second "U"-shaped hook 30 formed on the opposite end of the member 26.

The first hook 28 defines an area for acceptance of a portion of the shoe S, whereby a wearer may engage the first hook 28 with an eyelet E in the shoe. The second hook 30 defines a slot through which the wearer may thread the lace 14.

In a second configuration illustrated in Figures 6 and 7, the anchor element 12b comprises an member having a hook element 34 as the attaching portion 20b and an enclosed loop or eyelet 36 as the guiding portion 22b. The hook 34 and eyelet 36 define, respectively, a slot for insertion of the element 12 to an eyelet E of the shoe S and an aperture through which the lace 14 passes. The enclosed eyelet 36 has an interior surface which is smooth and low-friction, allowing the lace 14 to pass easily therethrough.

In a third configuration seen in Figures 8 and 9, the anchor element 12c is a flexible strip 40 having a ring 42

at a first end and a plug 44 at a second end. The attaching portion 20c of the anchor element 12c is defined by the interengagement of the projection 42 with the ring 44, while the guide portion 22c is defined by the portion of the anchor element 12c between its ends. The plug 44 is sized for insertion through an eyelet E and for engagement with the ring 42 of the anchor element 12c.

A fourth configuration of anchor elements is illustrated Figures 18-21. In this form of the invention, the anchor element 12d comprises a loop of relatively stiff, preferably coated, wire having a closed "U"-shaped configuration. The attaching portion 20d of the anchor element 12d comprises a first pair of U-shaped wire segments 46 formed at a first end of the anchor element 12d. The guiding portion 22d of the anchor element 12d comprises a second pair of "U"-shaped wire segments 48 formed at a second opposite end of the anchor element 12d.

Figures 10 through 12 illustrate a first embodiment of the releasable fastening means 24 for use in the shoe lacing system 10. As illustrated in Figures 10 and 11, the means 24 preferably comprises a segment 50 of hook or loop fastening material which is secured to the rear end R of the shoe S and a mating pair of releasable fastening tabs 52a,b having hook or loop fastening material on an inside surface thereof for engagement with the segment 50 of material on the shoe.

In a first version, illustrated in Figures 11a-b, each tab 52a,b is designed for use with a lace 54 comprising two cord members. In this form of the

invention, the tabs 52a,b are thin, sturdy members having a first outer side for engagement by the fingers of a user and a second, inner side, having hook or loop material located thereon. The lace 14 is coupled at the top and bottom of one of the edges of the tab 52a,b as illustrated in Figure 11a.

In a second version, illustrated in Figures 12a-b, each tab 52a,b comprises a thin, sturdy member looped around a leg of a triangular connecting frame 54. Each tab 52a,b has hook or loop material located on both outwardly facing surfaces. The lace 14 is attached to the triangular connecting frame 54.

Referring to Figures 2, 6, and 7, the elongated lace 14 which engages the anchor elements 12a-d is formed of at least one and preferably a pair of elongated strings, cords or wires for use in tightening the upper body B of the shoe S about the wearer's foot. The lace 14 is preferably made of a substantially inelastic, flexible material and at least the middle portion 16 thereof has a relatively low friction exterior surface.

As an example, the lace 14 may comprise a selected length of suitable strength fishing line, such as single-threaded Nylon line. The use of at least two elongated elements as the lace 14 provides for redundancy so that in case one of the two strings should break the other string will remain intact until the end of an event or activity in which the wearer is participating. The lace 14 may comprise a length of wire or other similar material.

As stated above, the middle portion 16 of the lace 14 preferably extends in criss-cross relationship about and

between the anchor elements 12a-d, rather than being threaded directly through the lace eyelets E as in the case of a traditional lace. Also, as mentioned above, the pair of opposite end portions 18a,b of the lace 14 extend
5 from anchor elements 12a-d near the rear or top end 32b of the tongue T. While the lace 14 is preferably routed between the elements 12a-d in criss-cross fashion, it may be routed therebetween in other lacing arrangements known in the art.

10 The smooth surface of the lace 14 substantially reduces the friction between the lace 14 and the anchor elements 12a-d when the wearer pulls on the opposite end portions 18a,b of the lace 14 to tighten the upper body B of the shoe S over the wearer's foot. The sections of the
15 lace 14 extending between opposing anchor elements 12a-d are placed uniformly under the same tension causing them to concurrently shorten merely by pulling rearwardly only on the opposite end portions 18a,b of the lace 14.

There is minimal friction between the anchor elements
20 12a-d and the exterior surface of the lace 14 as compared to the friction between the traditional lace and lace eyelets. Thus, pulling on the opposite end portions 18a,b of the lace 14 shortens the middle portion 16 of the lace 14 without the need of the wearer to adjust individual
25 sections of the lace 14 to achieve a secure fit. Also, the slippery or low friction surface of the lace 14 permits the lace 14 to constantly self-adjust and conform to the shape of the foot during movement of the wearer's foot.

Use of the first form of the present invention is as follows. First, the wearer (or shoe manufacturer) user places anchor elements 12a-d in each of the eyelets E of his shoe S. The wearer then threads a lace 14 through the anchor elements 12a-d.

The wearer disconnects the tabs 52a,b from the connecting segment 50 on the shoe S, thereby allowing for loosening of the lace 14. Once disconnected, the wearer loosens the lace 14 and places the shoe on this foot.

The wearer then tightens the lace 14 to secure the shoe around his foot. The wearer simply pulls on the end portions 18a,b of the lace 14 by pulling the tabs 52a,b rearwardly, as illustrated by arrow 56 in Figure 10. This movement causes a shortening of the length of lace 14 which traverses the anchor elements 12a-d, thus pulling the opposite rows of anchor elements 12 toward one another and tightening the upper body B of the shoe S.

The wearer then fastens the tabs 52a,b to the connecting segment 50 on the rear R of the shoe S by pressing the interengaging hook and loop connector material on these elements into engagement with one another, as illustrated by the arrow 58 in Figure 10. Once engaged, the interengaging hook and loop material prevents the opposite end portions 18a,b of the lace 14 from decreasing in length, which would result in the rows of anchor elements 12 to move away from one another and a loosening of the upper body B of the shoe S.

Preferably, the connecting segment 50 is of substantially greater length than each of the tabs 52a,b so that the wearer may engage it at various positions

along the first patch 50 depending upon the degree of tightness of the lacing system 10 desired by the wearer of the shoe S.

5 Figures 13, 14 and 17 illustrate a second form of the present invention, where the anchor elements are in the form of lace guide means 80.

10 The guide means 80 preferably comprise short arcuate-shaped tubular guide segments 82 that are mounted between inner and outer layers L on the upper body B of the shoe S in parallel rows on opposite sides of the tongue T of the shoe S. Each guide segment 82 comprises a tubular body having a first open end 86a, a second open end 86b, and a passage therebetween. The segments 82 are mounted on the shoe S so that their open ends 86a,b are accessible to the wearer, as illustrated in Figure B.

15 The segments 82 preferably replace the anchor elements, and as illustrated, eliminate the need for eyelets E. It is possible, however, to mount the segments 82 in alignment with the eyelets E which are present in an already manufactured shoe.

20 Preferably, the lace 14 is threaded through and extends in criss-cross relationship between the tubular guide segments 62.

25 The guide means 80 preferably also includes a pair of curved tubular guides 84a,b mounted on opposite sides of the upper body B of the shoe S. Like the tubular guide segments 82, the curved tubular guides 84a,b are preferably tubular members having a first open end 88a, second end 88b, and a passage therebetween. Preferably, 30 the first end 88a of each tubular guide 84a,b is located

outside of the upper body B of the shoe S adjacent to and rearwardly from respective rear ends of the rows of tubular guide segments 82, and extends therefrom in between inner and outer layers of the body B of the shoe S, and then passes through a slit in the outer surface of the shoe to its second end 88b located on the outer surface of the shoe S at the rear end R thereof.

The tubular guide segments 82 and curved tubular guides 84 can be attached in any suitable known manner to the exterior surface or inner walls of the opposite sides of the upper body B of the shoe S. The opposite end portions 18a,b of the elongated lace 14 are threaded through respective tubular guide 84 so that their terminal ends emerge from the rear ends of the tubular guides 84 at the rear end R of the shoe S.

Figure 17 illustrates use of this second form of the present invention on a boot 98. Here, a first system of guides and a lace are used to adjust the lower portion of the boot, and a second system of guides and a lace are used to adjust the top portion of the boot.

Figures 13 through 15 illustrate a second embodiment of the releasable fastening means 24, which embodiment is preferably used with the embodiment of the invention illustrated in Figures 13-15 and 16, but which may be used with the other forms of the invention herein described. In this embodiment, the means 24 preferably comprises an anchor strip 66 and a strap 68 connected to the lace 14.

The anchor strip 66 preferably comprises a section of material secured along opposite vertical edge portions 67a,b thereof to the rear end R of the upper body B of the

shoe S and having a central portion 70 with hook or loop fastening material secured thereto.

The strap 68 is a flexible member having a first end 72a and a second end 72b. The first end 72a of the strap 68 is preferably located below the anchor strip 66, which is positioned above the second ends 88b of the curved tubular guides 84a,b. The strap 68 extends under the anchor strip 66 to the second end 72b. The ends 18a,b of the lace 14 are connected to the first end 72a of the flexible strap 68.

A section of hook or loop material 74 is located on the outer surface of the central portion 70 of the strip 66, while a mating section of hook or loop material 76 is positioned on the inner surface of the strap 68 at the second end 72b thereof.

The strap 68 slidably extends upwardly between the anchor strip 66 and rear end R of the shoe S so as to be movable upwardly and downwardly relative to the anchor strip 66. Preferably, the second end 72b of the strap 68 includes a loop 78 for engagement by a finger of a wearer, whereby the wearer may effectuate movement of the strap 68 with respect to the strip 66.

To quickly and easily secure the upper body B of the shoe S over the wearer's foot, the wearer inserts a finger through the loop 78 and pulls upward on the flexible strap 68. First, this movement causes the strap 68 to be disengaged from the strip 66. Further upward movement causes the lace 14 to be pulled upwardly, shortening the length of the middle portion 16 of the lace 14 and thereby pulling the opposite rows of tubular guide segments 82

toward one another and tightening the upper body B of the shoe S. Then, the wearer presses the hook or loop material 76 on the strap 68 against the mating material 74 on the strip 66 to prevent movement of the flexible strap 68, and thus loosening of the lace 14.

Figure 16 illustrates a variation of the above-referenced means for releasably fastening 24, in which the strap 68 is secured by means of a clamp 90. Preferably, the clamp 90 comprises a lever arm 92 and a base 94 mounted on the rear end R of the upper body B of the shoe S above the second ends 88b of the curved tubular guides 84a,b.

As in the arrangement described above, a flexible strap 68 is connected at its lower end to the ends 18a,b of the lace 14 and preferably includes a loop 78 at the first end thereof. The strap 68 passes between the outwardly facing surface of the base 94 of the clamp 90 and the lever arm 92 which is actuatable between a clamped condition and an unclamped condition.

In the position illustrated in Figure 16, the lever arm 92 extends upwardly, and leaves a passage for the strap 68 between it and the base 92. When a wearer pivots the arm 92 downwardly, a bulge 96 on the arm rotates in the direction of the strap 68, pressing it firmly against base 92, preventing movement of the strap 68.

Using this form of the invention, a wearer actuates the clamp 90 to its unclamped condition and inserts a finger through the loop 78 and pulls upward on the strap 68. This shortens the length of the middle portion 16 of the lace 14 thereby pulling the opposite rows of tubular

guide segments 82 toward one another and tightening the upper body B of the shoe S. Then, the wearer actuates the clamp 90 to its clamped condition to hold the strap 68 in a fixed position. This prevents the strap 68 from moving downward and thereby allowing the length of the middle portion 16 of the lace 14 from increasing so that the rows of tubular guide segments 82 can move away from one another and loosen the upper body B of the shoe S.

While several specific embodiments of the releasable fastening means 24 are described and illustrated, many others may be used in the present invention. For example, snaps, hooks or other clamping means may be used for adjusting the position of the ends 18a,b of the lace 14.

The above-referenced shoe lacing system has many advantages over the prior art. As detailed above, one of the problems associated with using present lacing systems is the time needed to adjust the lace along the eyelets and then tie its free ends. While it is always undesirable to expend time to tie one's shoes, the time necessary is critical in some instances. For example, in many athletic events, a competitor must change shoes one or more times during the event. The time necessary to lace and unlace the shoes to take them on and off increases the total time of the competitor in finishing the event.

Using the system of the present invention, a wearer can quickly lace and unlace his shoes. In particular, the wearer only need use the releasable fastening means of the invention to secure and unsecure the lace.

Moreover, because the lace moves smoothly through the guides/or anchor elements, the wearer does not need to adjust individual sections of the lace between eyelets. Instead, movement of the releasably fastening means effectuates movement of the lace along its entire length.

Another advantage of the present invention is that it facilitates better shoe fit. In present lacing systems, the distance of the lace travels between eyelets may vary long the shoe because of variations in the width of the users foot. Because the lace often binds at each eyelet, the user has a difficult time adjusting the lace distance between individual eyelets. Thus, the lace may cause the shoe to be too tight in some areas, or too loose in others.

In the system of the present invention, the lace moves freely through the guides/anchor elements. Thus, the lace has uniform tension along its length, causing the shoe to be tightened around the wearers foot evenly along its length.

Another advantage of the present invention relates to the fact that the lace is not tied across the top of the wearer's foot. Using traditional laces, the wearer must pull the ends of the laces very taunt, stretch them towards each other across the top of his foot, and then tie them in a knot to prevent the loosening of the lace. This often results in pinching or excessive pressure across the top of the users foot at the ankle.

In the lacing system of the present invention, each end of the lace traverses from the last row of anchor elements to the back of each shoe on opposite sides of the

shoe. In other words, the ends of the lace do not cross one another on the top of the wearer's foot, eliminating the pinching and pressure associated with use of common lacing systems.

5 It will be understood that the above described arrangements of apparatus and the method therefrom are merely illustrative of applications of the principles of this invention and many other embodiments and modifications may be made without departing from the
10 spirit and scope of the invention as defined in the claims.

I CLAIM:

1. A lacing system for use with a shoe having a body and a tongue comprising:

5 a plurality of anchor elements, said anchor elements each having a first portion for mounting to the shoe along respective opposite sides of the tongue of the shoe and a second portion for engagement of a lace;

a lace having a middle section for engagement with the anchor elements and two ends; and

10 releasable fastening means located on said shoe for releasably fastening said ends of said lace to the shoe.

2. The lacing system of Claim 1 wherein said releasable fastening means is located at a rear portion of said shoe.

5 3. The lacing system of Claim 2 wherein said anchor element is a loop of wire bent into a U-shaped configuration.

10 4. The lacing system of Claim 3 wherein said attaching portion of said anchor element is a first pair of U-shaped wire segments formed at a first end of said anchor element and said guiding portion of said anchor element is a second pair of U-shaped wire segments formed at a second opposite end of said anchor element.

5. The lacing system of Claim 2 wherein said anchor element is a member having a first end and a second end in the shape of a hook.

5 6. The lacing system of Claim 1 wherein said anchor element has a ring at a first end for engagement with a plug at a second end.

7. The lacing system of Claim 1 wherein said anchor element has an enclosed eyelet formed on one end and a hook on another end.

10 8. The lacing system of Claim 1 wherein said releasable fastening means comprises a first segment of hook or loop material secured to the shoe and a pair of tabs, each tab connected to one of said ends of said lace, each tab having a segment of hook or loop material
15 positioned thereon for mating engagement with said first segment of material on said shoe.

9. The lacing system of Claim 1 further comprising guide means located on said shoe for guiding said lace from anchor elements located near a top end of said
20 tongue to a rear area of said shoe.

10. The lacing system of Claim 9 wherein said guide means comprises a pair of tubular hollow guides extending from near said tongue of said shoe to a rear end thereof.

11. The lacing system of Claim 9 wherein said guide
25 means comprise a pair of curved tubular guides mounted on opposite sides of the upper body of the shoe and extending from adjacent the top end of said tongue to the rear end of the shoe, said curved tubular guides being hollow to thread said opposite end portions of said elongated lace therethrough.

12. The lacing system of Claim 1 wherein said releasable fastening means comprises an anchor strip secured to the rear end portion of the shoe and a flexible strap connected at a lower end thereof to said ends of
5 said lace, said strap being movable upwardly and downwardly relative to said anchor strip.

13. The lacing system of Claim 1 wherein said releasable fastening means comprises a releasable clamp mounted on the rear end portion of the shoe and a flexible strap connected at a lower end to said ends of said lace, said strap being movable upwardly and downwardly relative to said releasable clamp when said clamp is in an unclamped condition, and said strap being held in a stationary clamped position relative to said releasable clamp when said clamp is in a clamped position.

14. The lacing system of Claim 1 wherein said lace comprises at least one elongate element of substantially inelastic flexible material having at least an exterior surface which is of relatively low friction.

15. The lacing system of Claim 1 wherein said lace comprises a pair of elongate elements of substantially inelastic flexible material and wherein at least the middle section thereof has an exterior surface which is of relatively low friction.

16. A lacing system for use on a shoe comprising:
a lace comprising an elongate, flexible element having a middle portion and two ends, at least said middle portion having an exterior surface with a relatively low friction;

means for securing said lace to an upper body of the shoe along respective opposite sides of a tongue of the shoe; and

means for releasably fastening the end of said lace to a rear end portion of the shoe.

17. The lacing system of Claim 16 wherein said lace is formed of a pair of strands.

15 18. The lacing system of Claim 16 wherein said
releasable fastening means comprises a section of hook or
loop material located on said shoe and a tab connected to
each end of said lace, each tab having a section of hook
or loop material thereon for engagement with the section
of material on said shoe.

20 19. The lacing system of Claim 16, wherein said
means for securing comprises hollow tubular segments.

20. The lacing system of Claim 18 further including
guide means for routing the lace from said means for
securing to said rear end of said shoe.

21. The lacing system of Claim 20 wherein said guide
means comprises a pair of tubular guides.

22. The lacing system of Claim 20, wherein said
guide means comprises a passage through said body of said
shoe.

5 23. In combination, a shoe having an upper body and
a plurality of lace eyelets arranged in a pair of rows
along on said upper body on opposite sides of a tongue of
said shoe, a lacing system comprising:

an anchor element mounted to substantially all of
said lace eyelets;

10 a lace having a middle section for engagement with
said anchor elements and two ends;

15 guide means positioned on the shoe adjacent to and
rearwardly a rear row of lace eyelets for guiding said
lace from said rear row of lace eyelets to a rear portion
of said shoe; and

releasable fastening means located at the rear of the shoe for releasably fastening said ends of said lace to said shoe.

24. The lacing system of Claim 23 wherein said lace comprises a pair of elongate, flexible elements having at least a middle section with an exterior surface having a relatively low friction.

25. The lacing system of Claim 23 wherein said guide means comprises a pair of eyelets defined on the upper body of the shoe adjacent to and rearwardly of said rear ends of said rows of anchor elements.

26. The lacing system of Claim 23 wherein said guide means includes a pair of hollow tubular guides mounted on opposite sides of the upper body of the shoe and extending from adjacent to the rear ends of the rows of said securing means to the rear end of the upper body of the shoe.

5

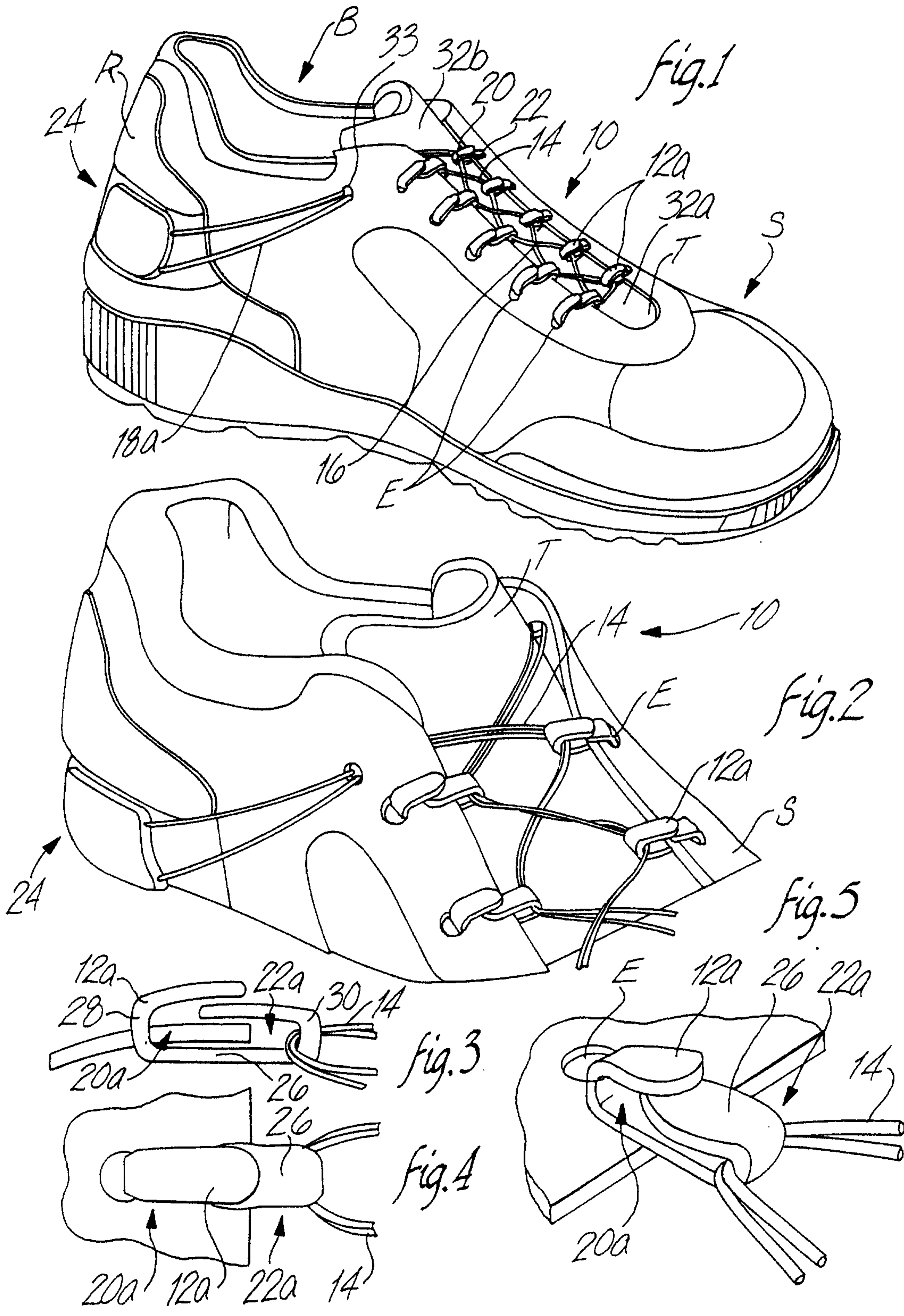

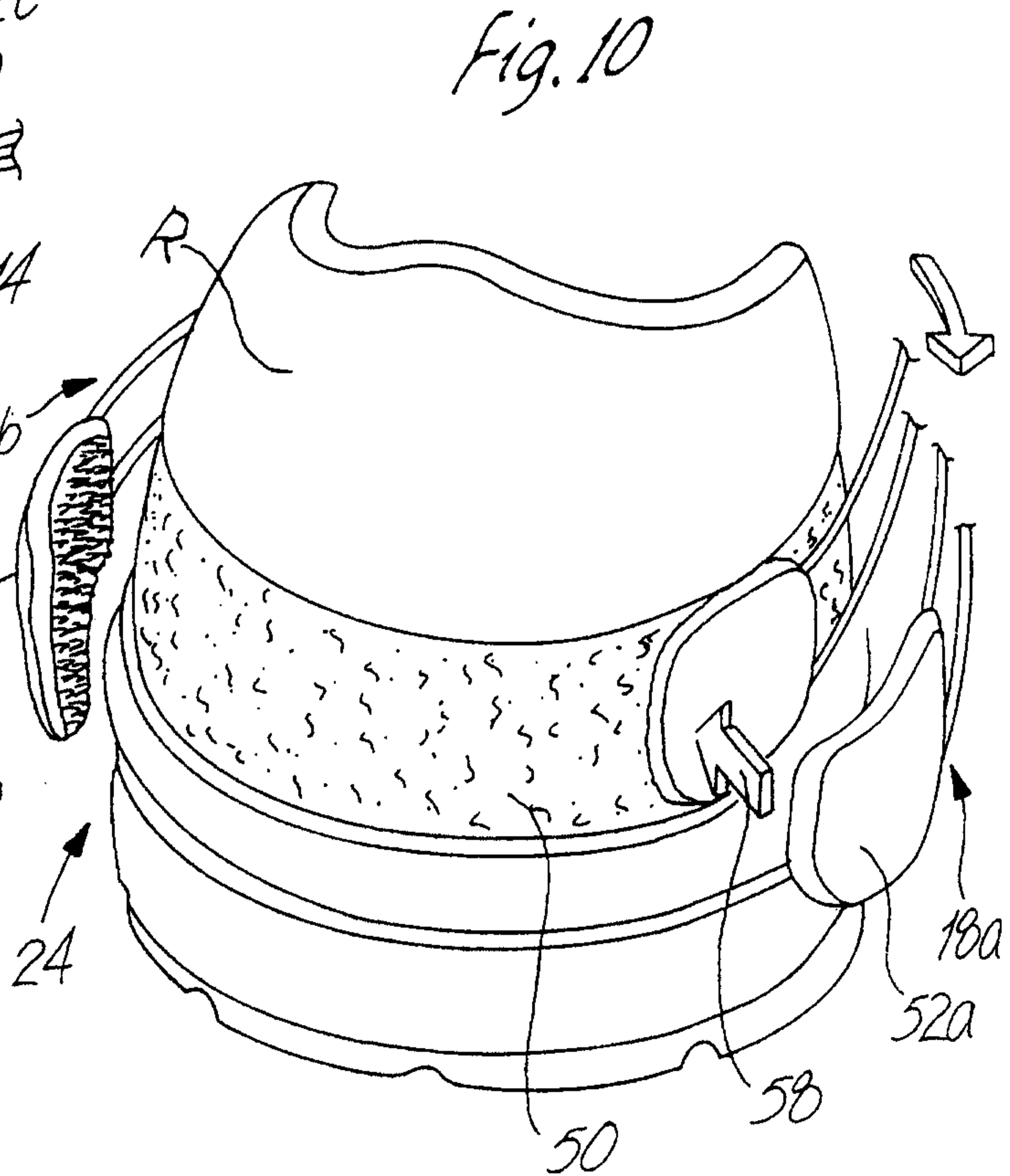
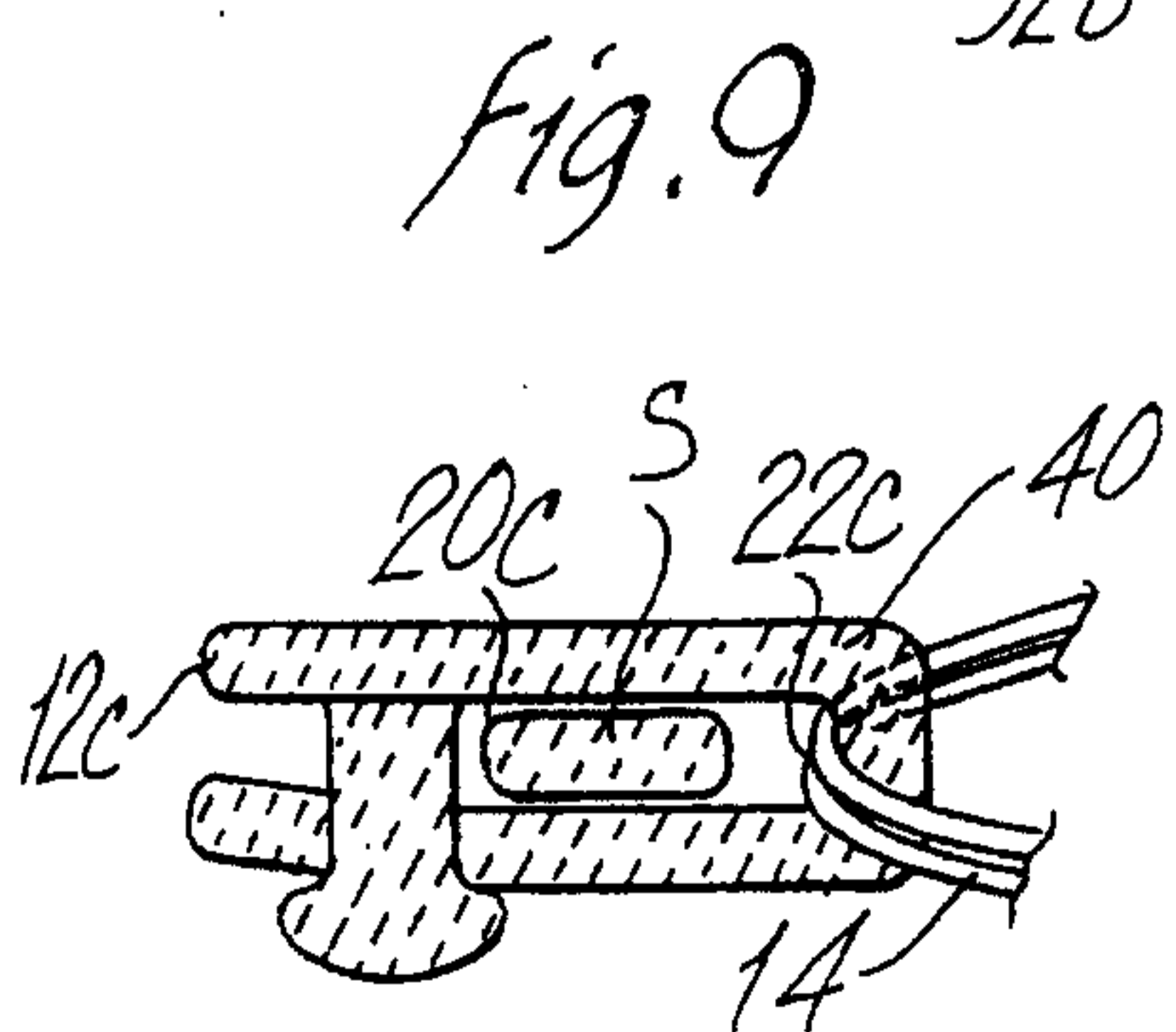
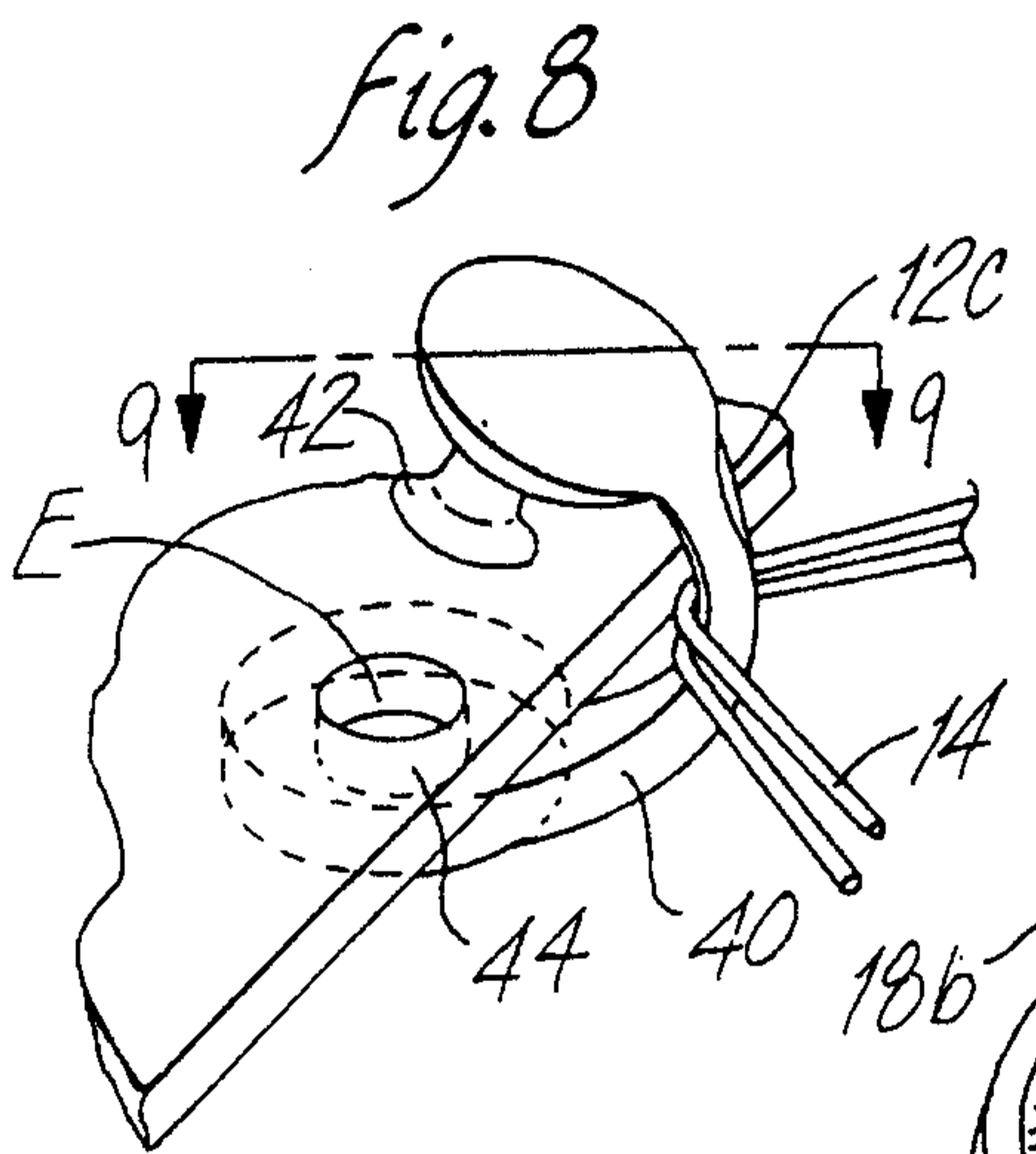
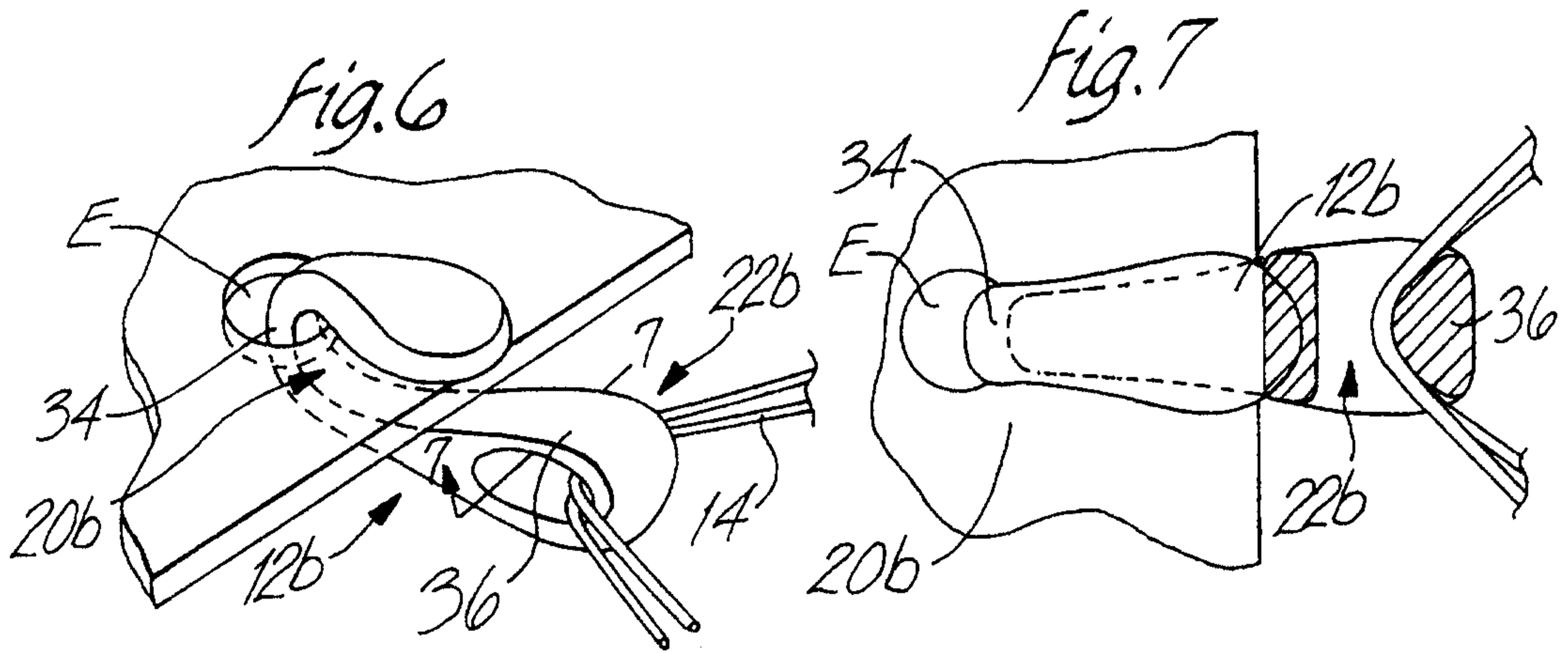

Fig. 11a

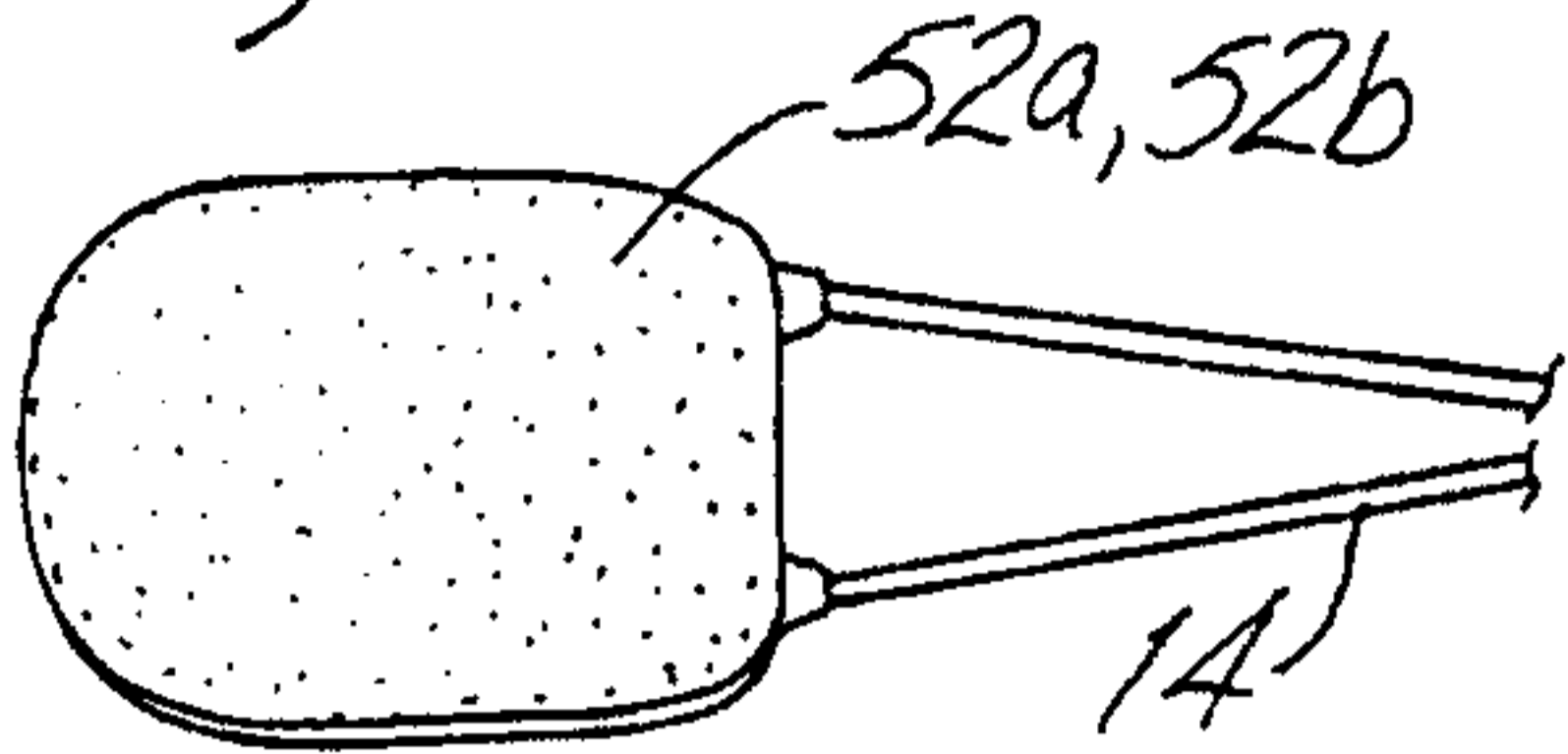

Fig. 12a

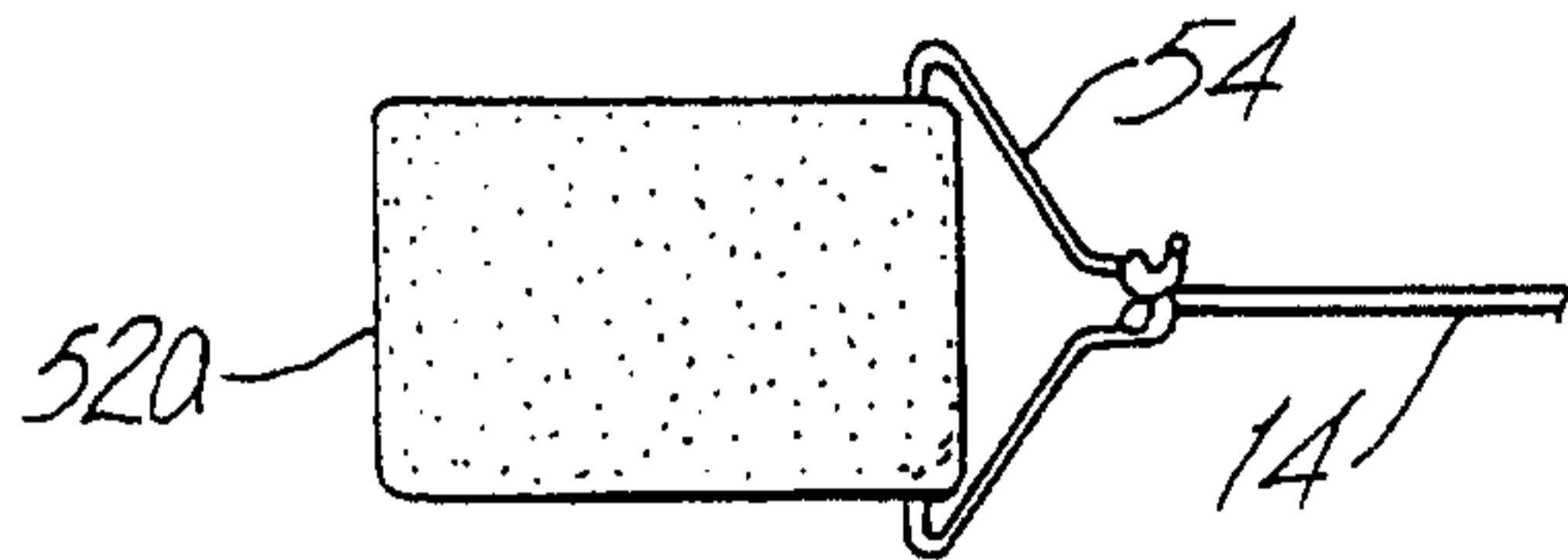

Fig. 11b

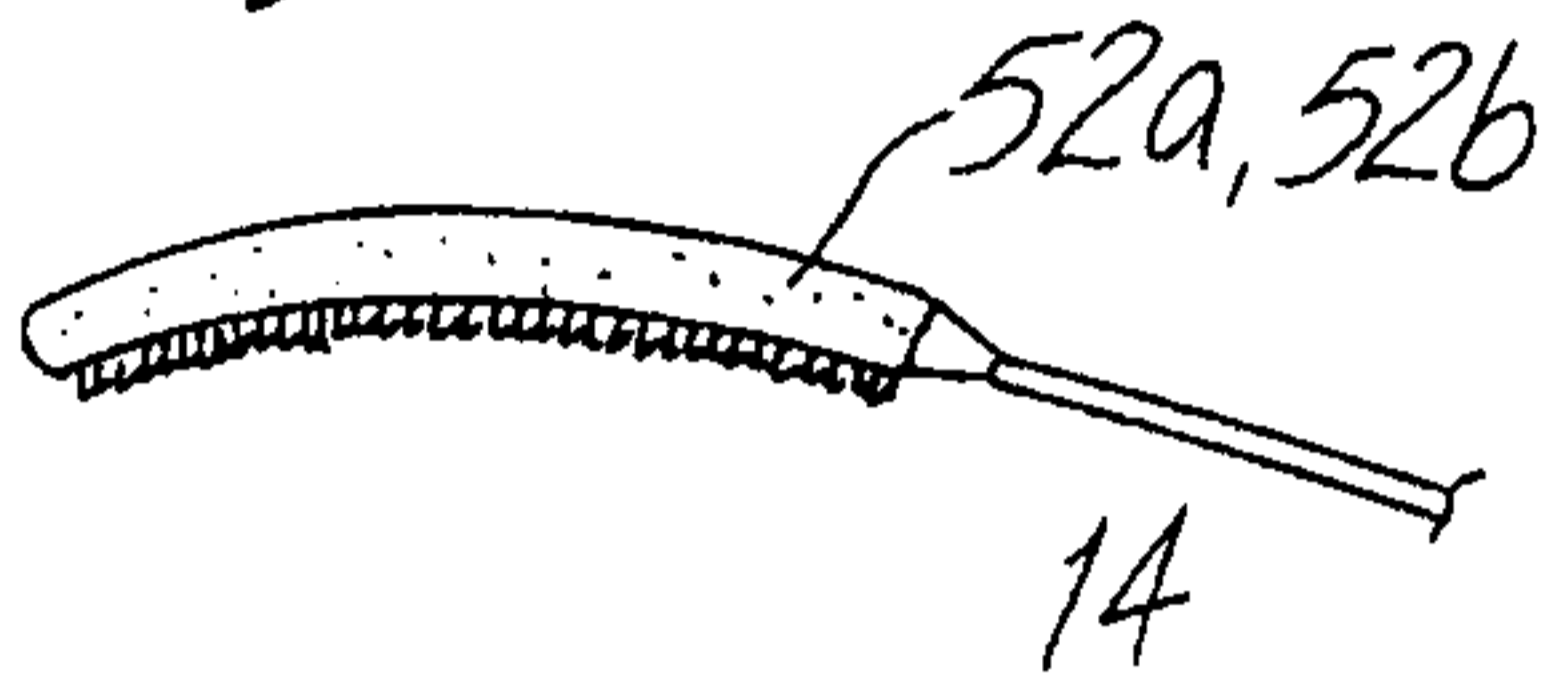

Fig. 12b

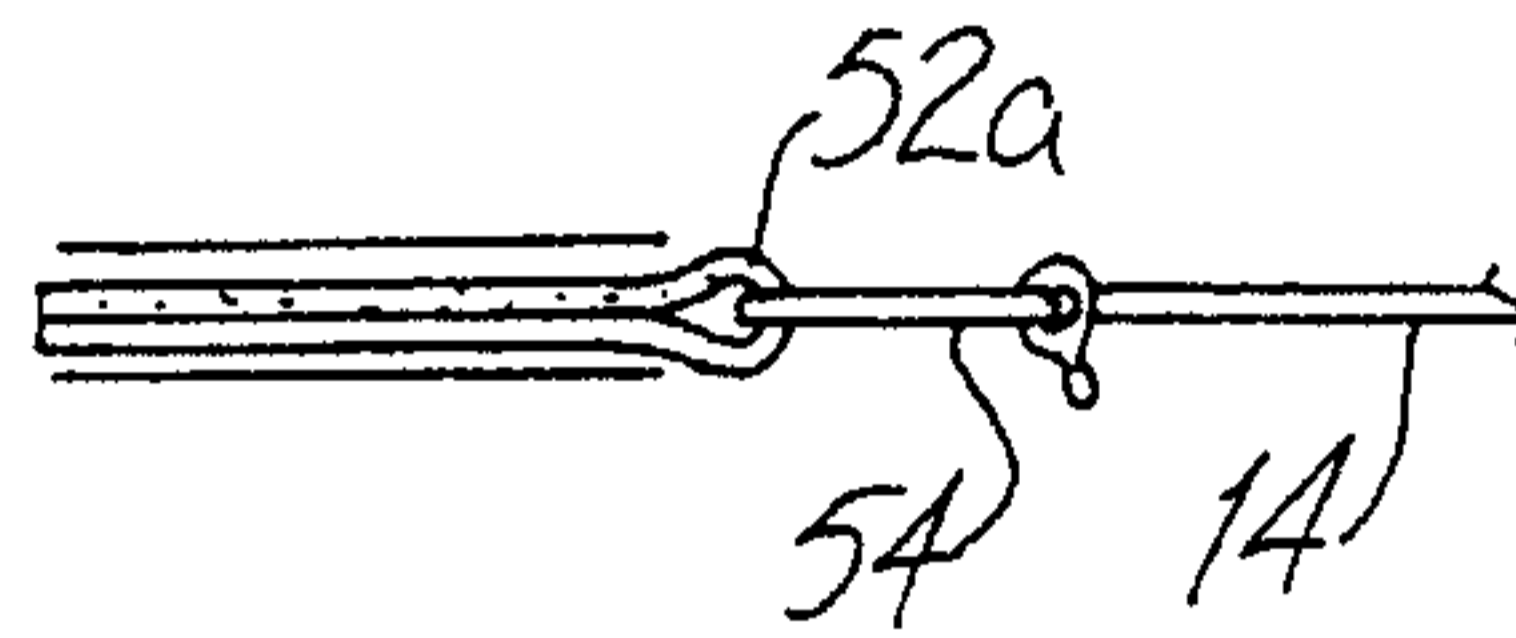
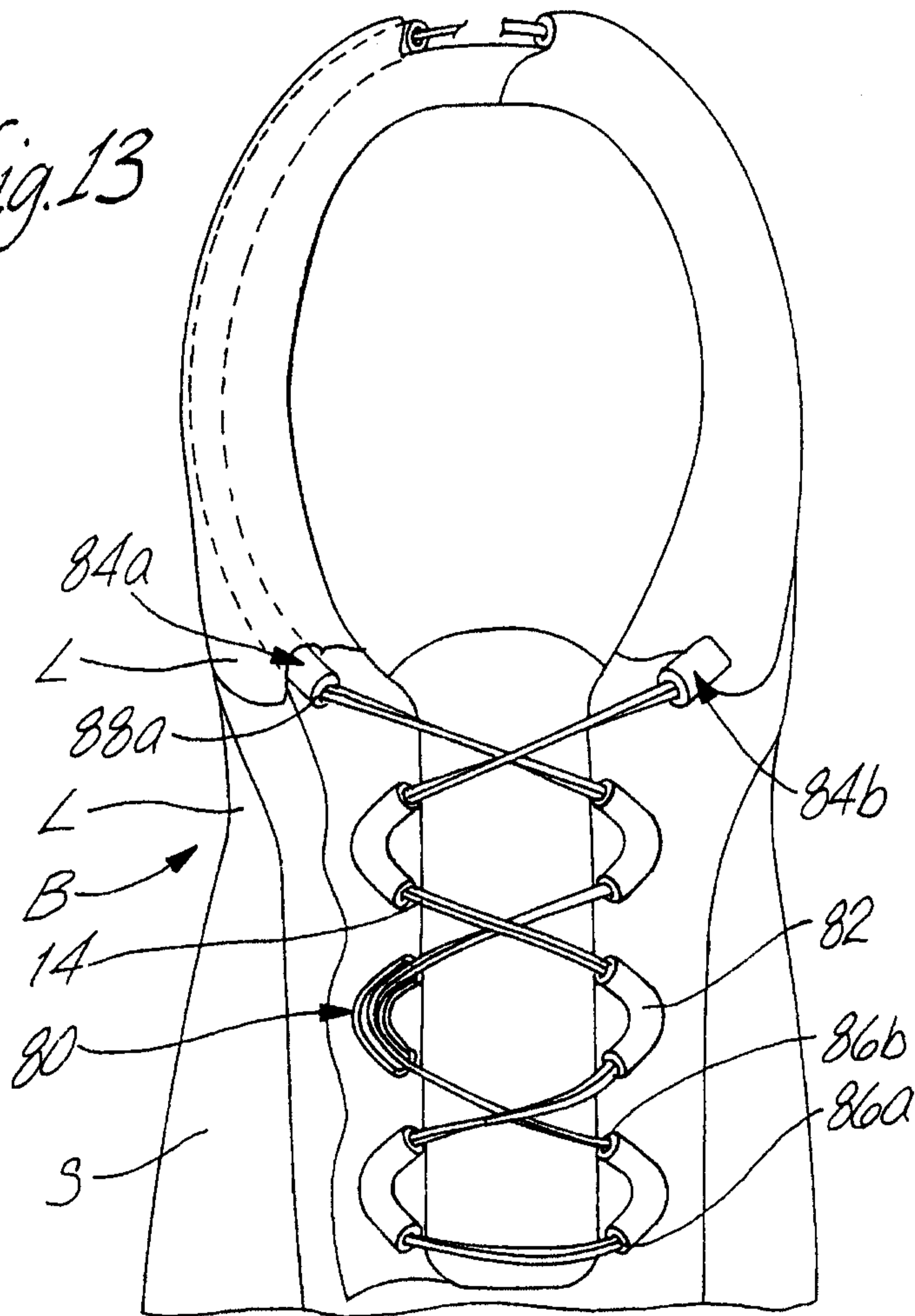
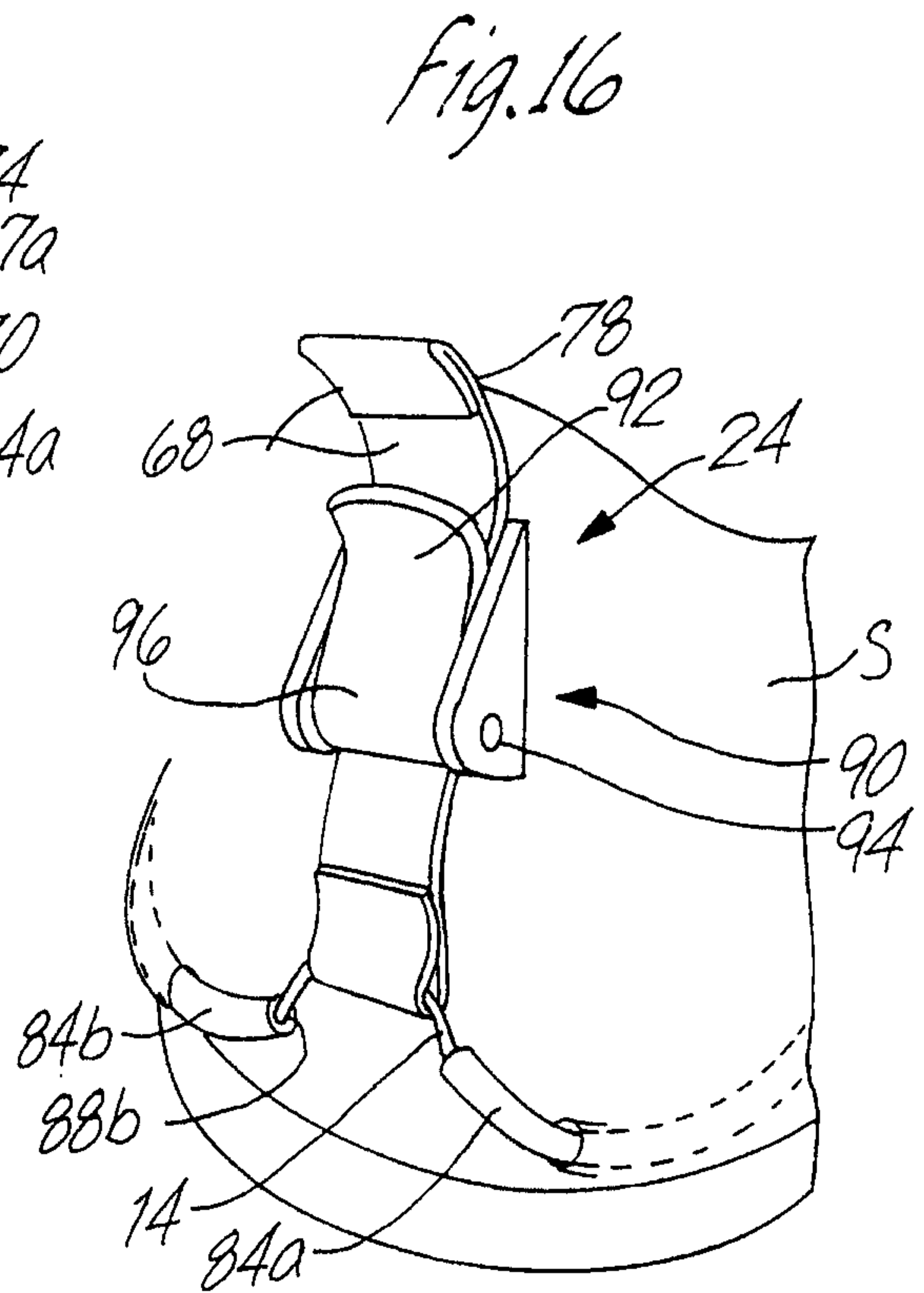
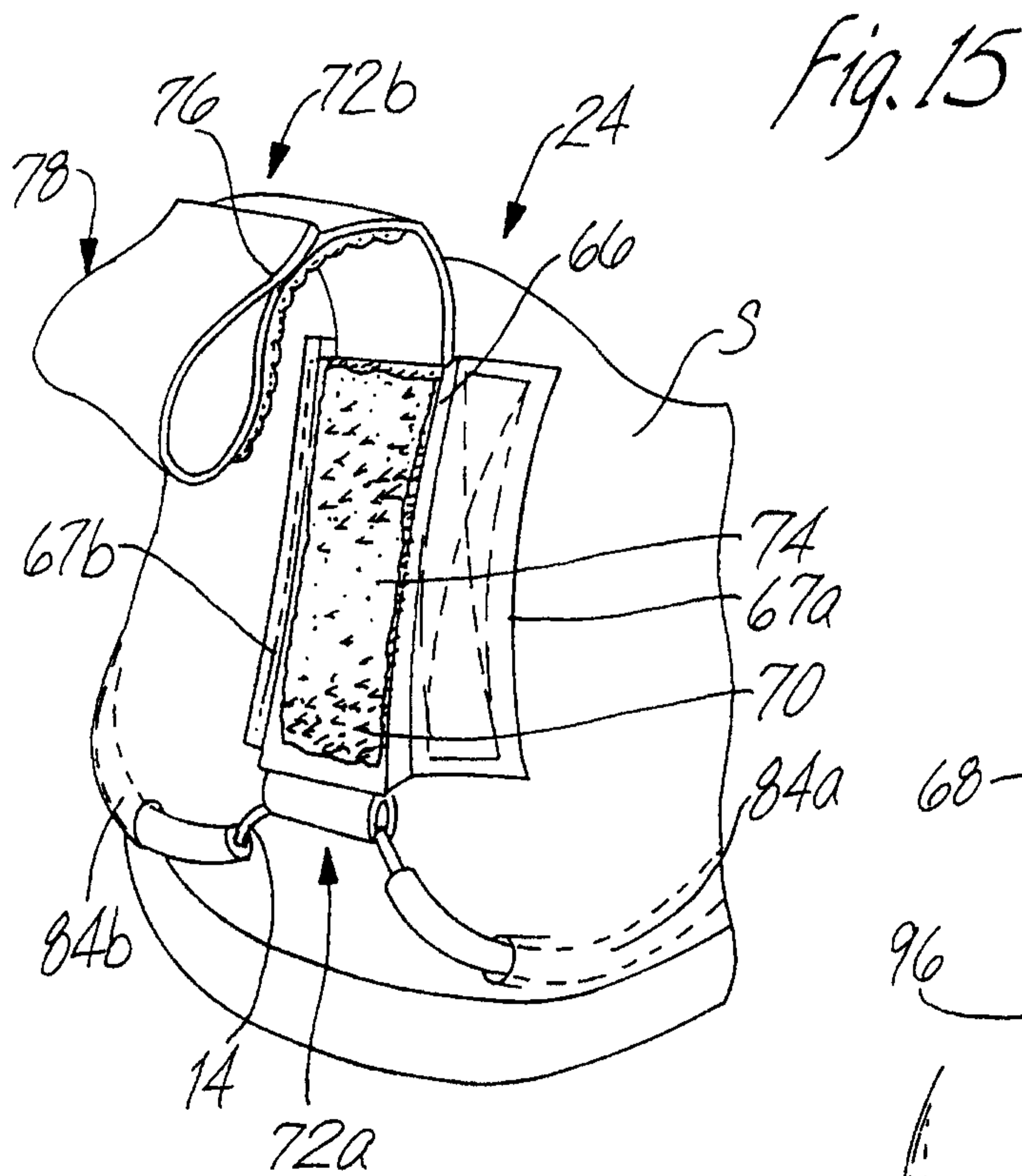
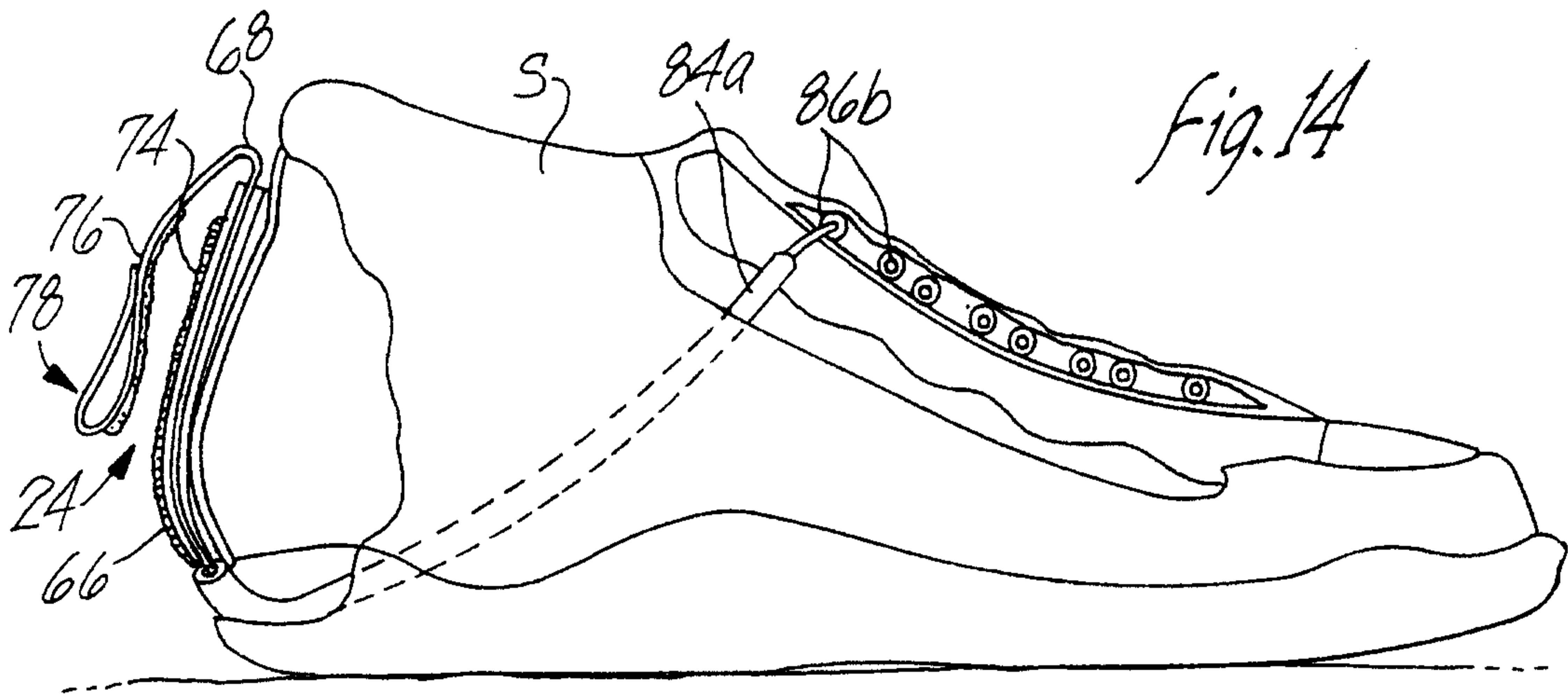

Fig. 13





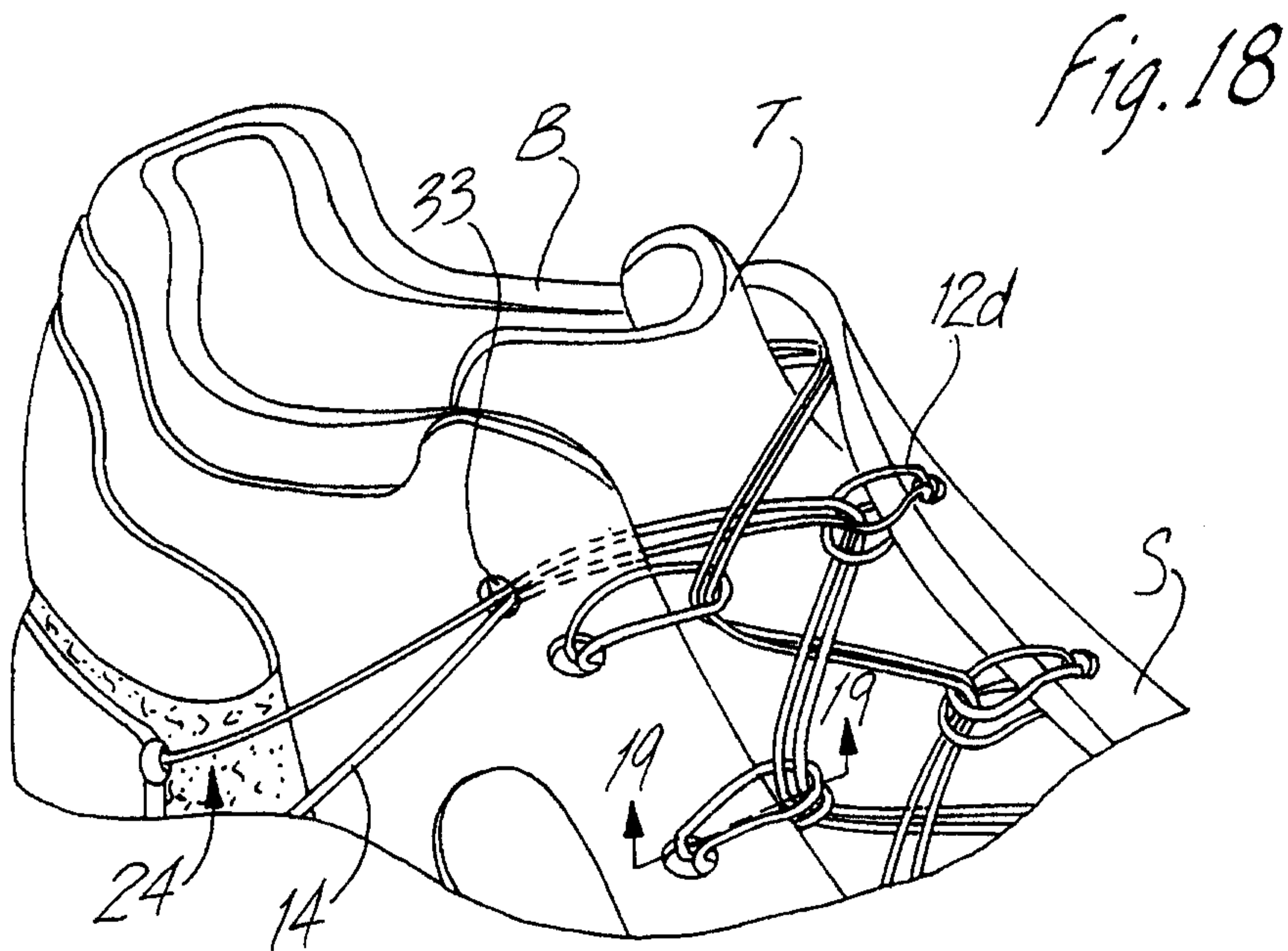
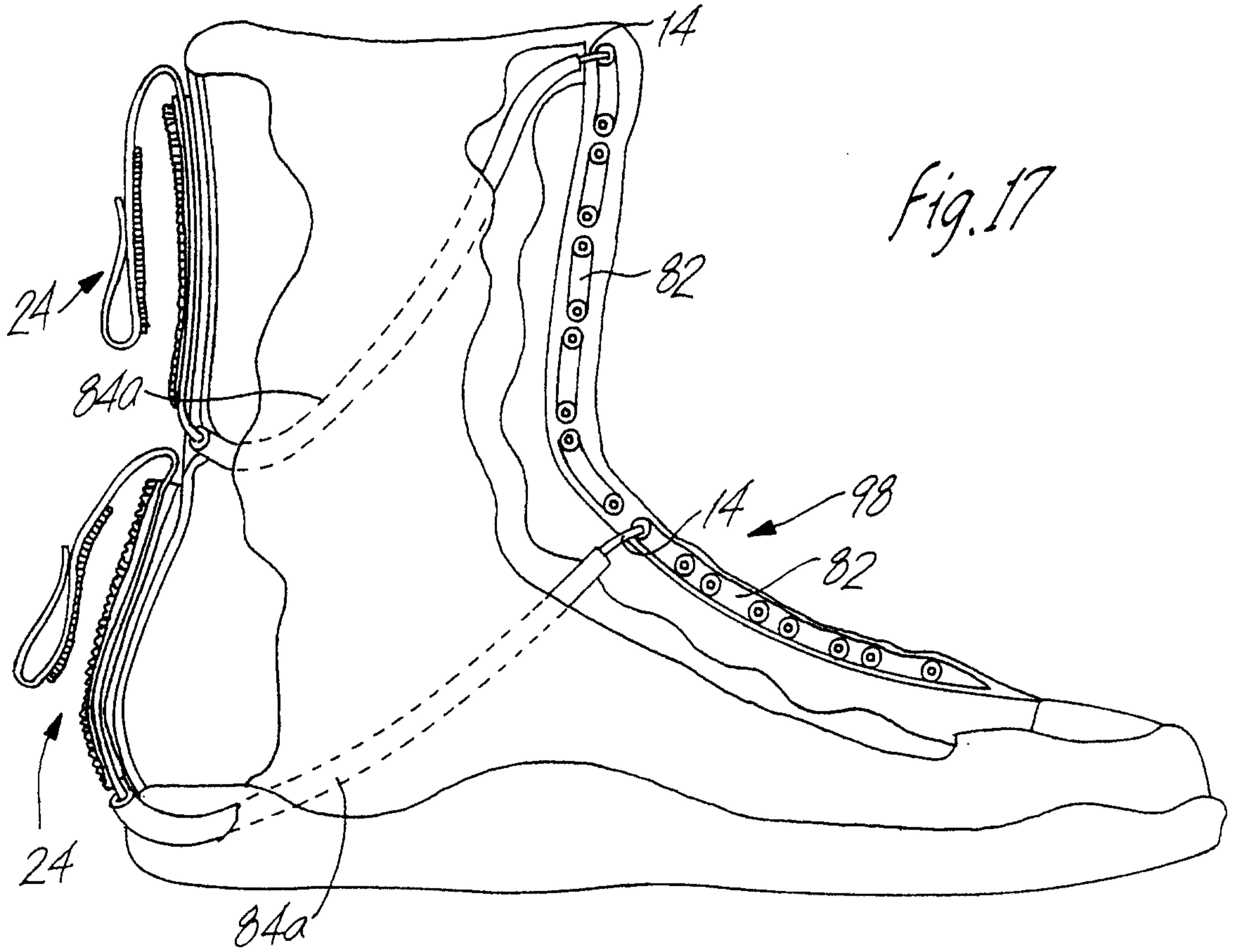

Fig. 19

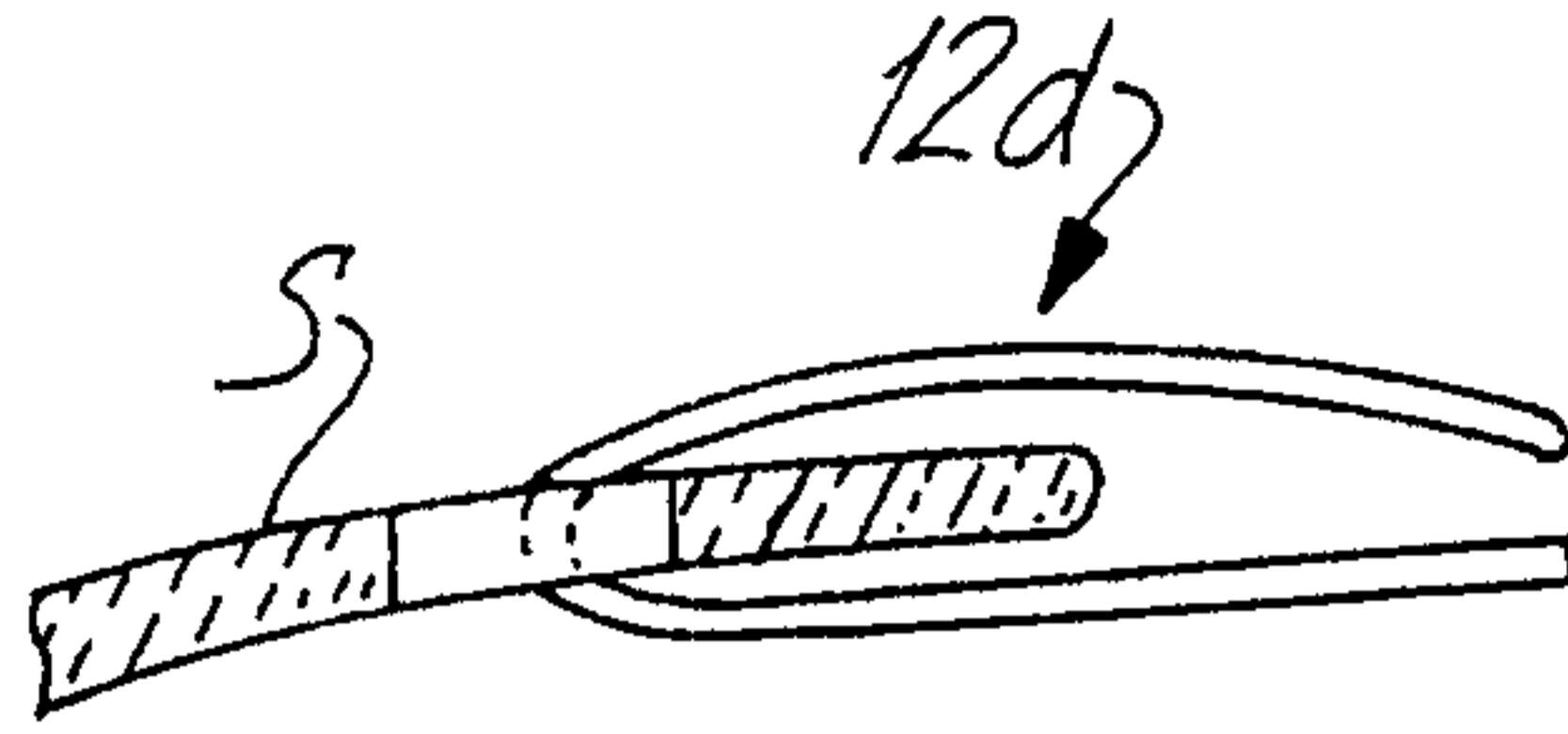

Fig. 20

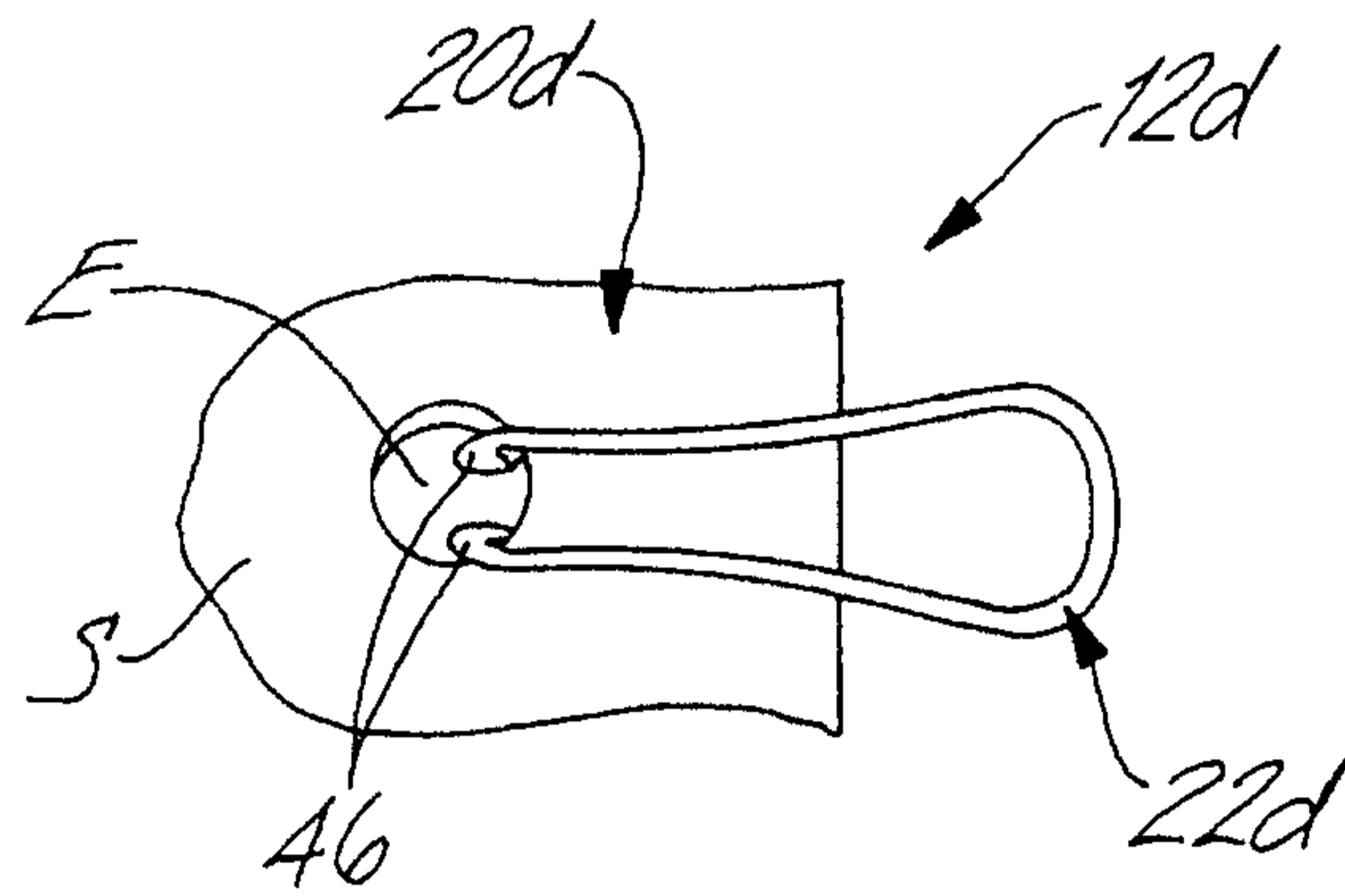

Fig. 21

