



US 20180037195A1

(19) **United States**

(12) **Patent Application Publication**  
**DeGennaro**

(10) **Pub. No.: US 2018/0037195 A1**

(43) **Pub. Date: Feb. 8, 2018**

(54) **WIPER BLADE ASSEMBLY PROTECTOR AND METHOD OF PROTECTING A WIPER BLADE ASSEMBLY**

**Publication Classification**

- (51) **Int. Cl.**  
*B60S 1/04* (2006.01)
- (52) **U.S. Cl.**  
CPC ..... *B60S 1/0491* (2013.01); *B60S 2001/3843* (2013.01)

(71) Applicant: **Sergio K. DeGennaro**, Westbury, NY (US)

(72) Inventor: **Sergio K. DeGennaro**, Westbury, NY (US)

(57) **ABSTRACT**

(21) Appl. No.: **15/789,671**

(22) Filed: **Oct. 20, 2017**

**Related U.S. Application Data**

(63) Continuation of application No. 15/399,870, filed on Jan. 6, 2017.

(60) Provisional application No. 62/275,844, filed on Jan. 7, 2016.

A protector for a windshield wiper assembly includes an elongated body defining a cavity receiving at least the blade of the wiper assembly. The cover is used to protect the assembly from snow, ice, mud, etc. Preferably, the assembly is pivoted away from the windshield before the blade is inserted into the body. Caps with decorative covers are provided at the ends of the body. The body may be made of a translucent material and may be covered with logos, insignia and other advertising materials.

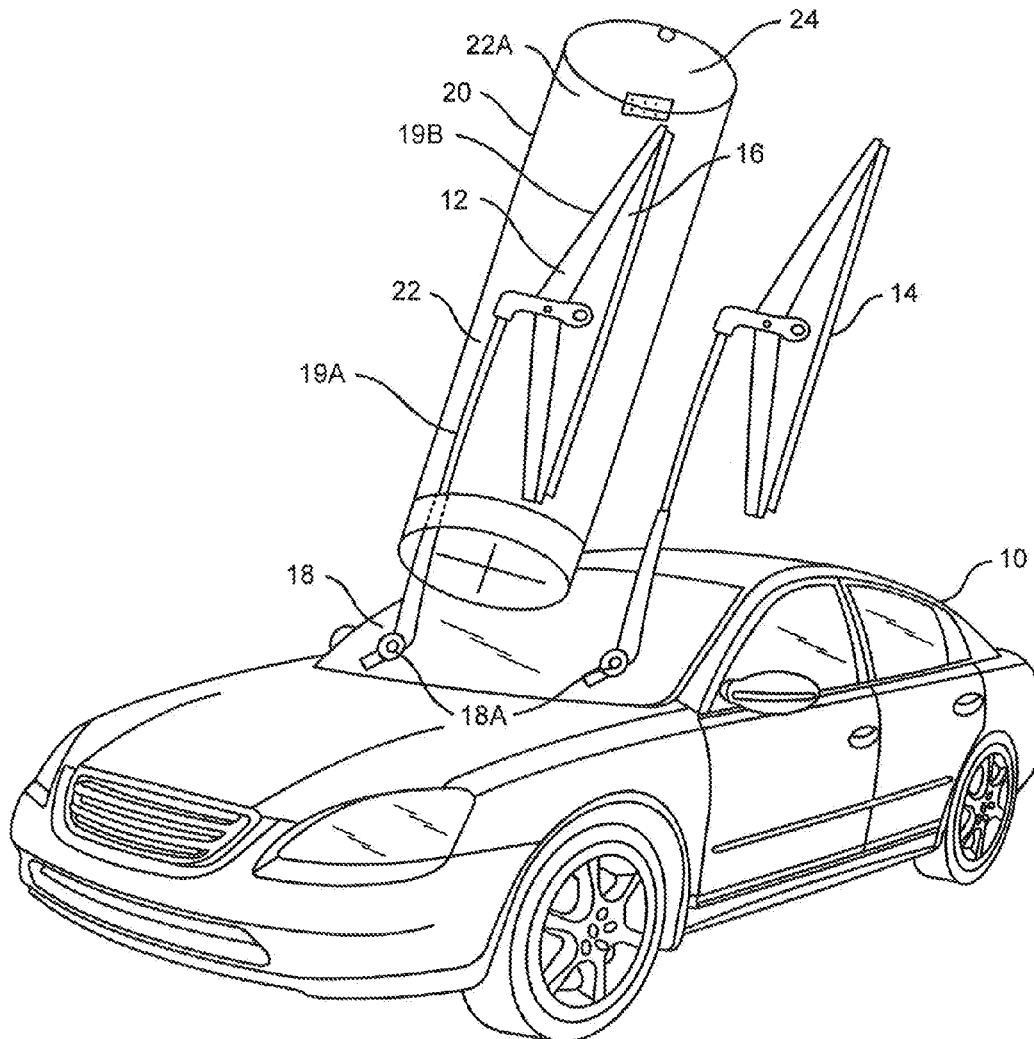

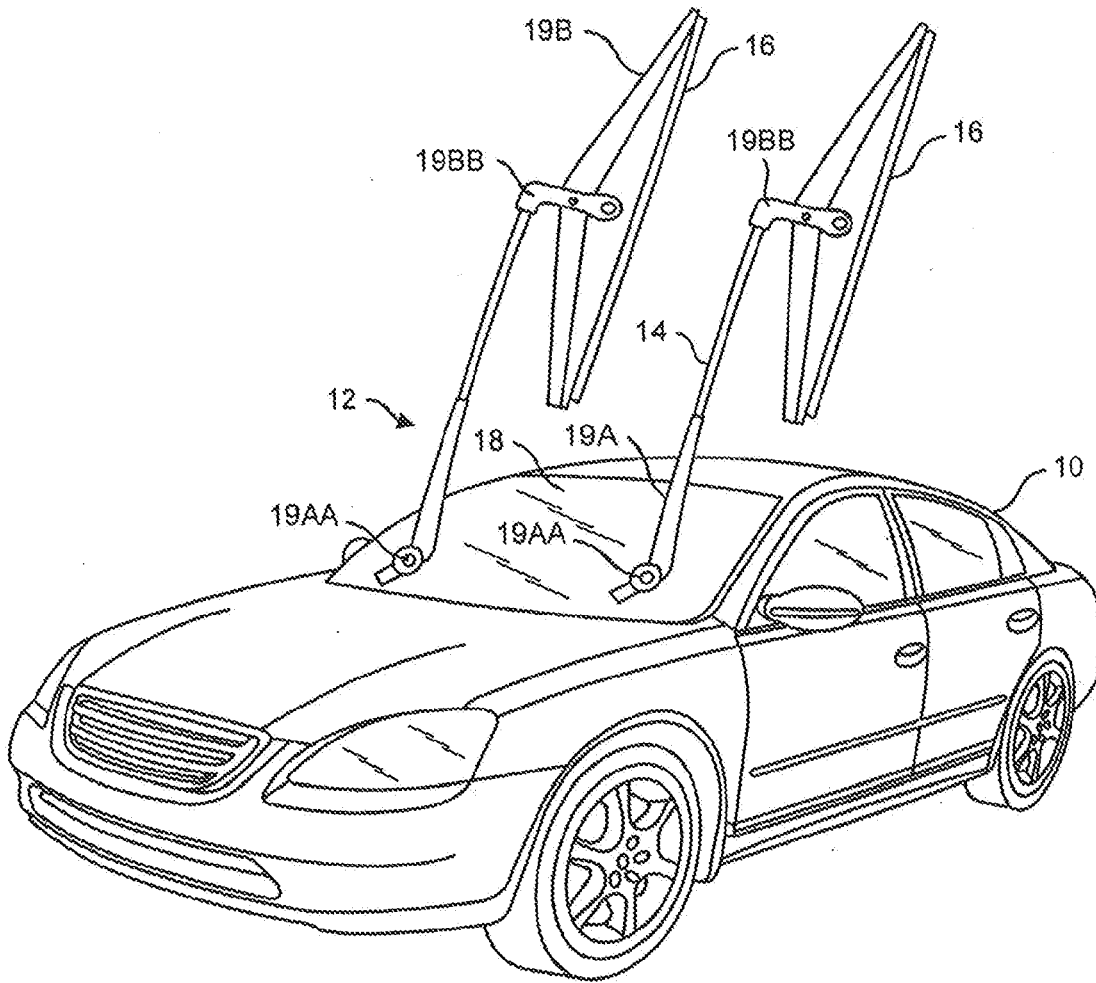

FIG. 1  
PRIOR ART

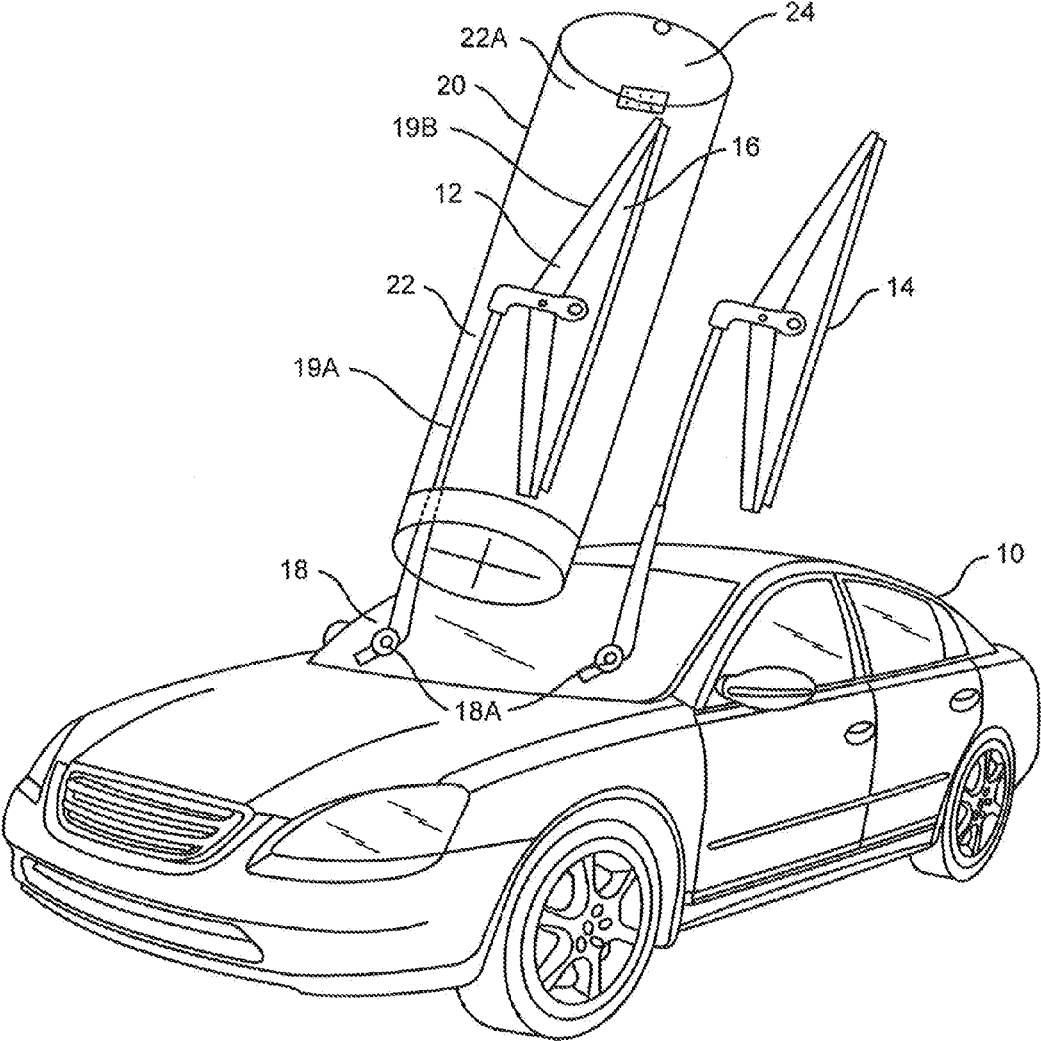

FIG. 2

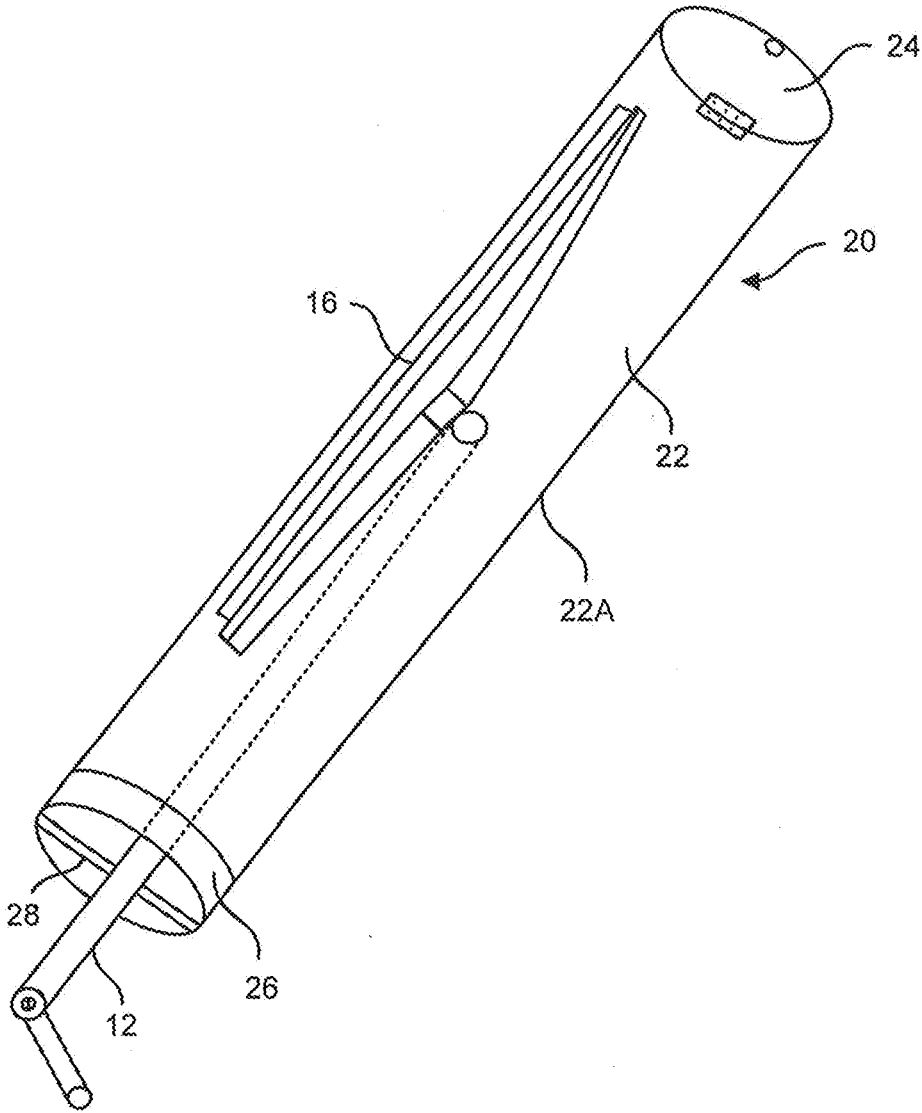

FIG. 3

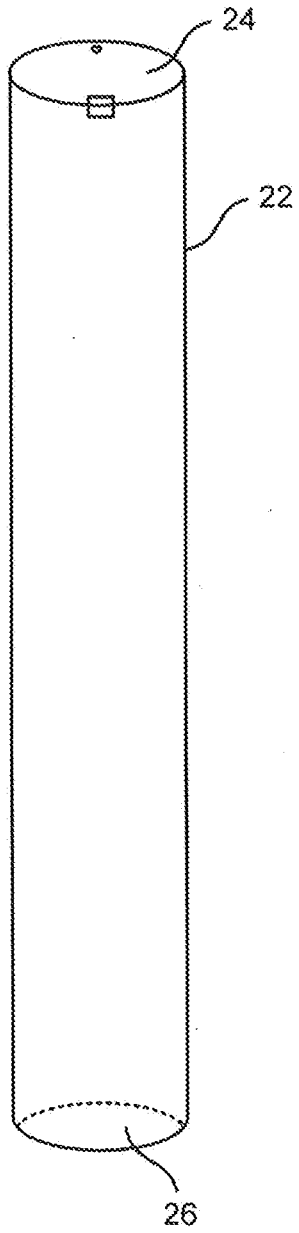

FIG. 4

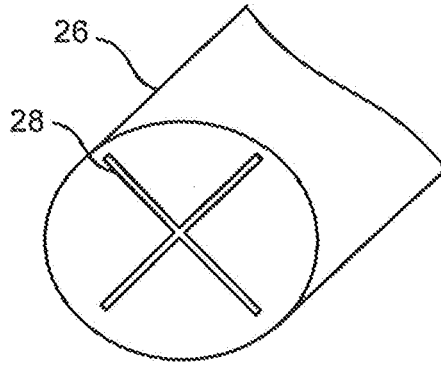

FIG. 4A



FIG. 4B

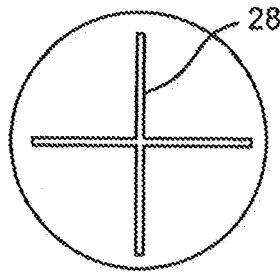

FIG. 4C

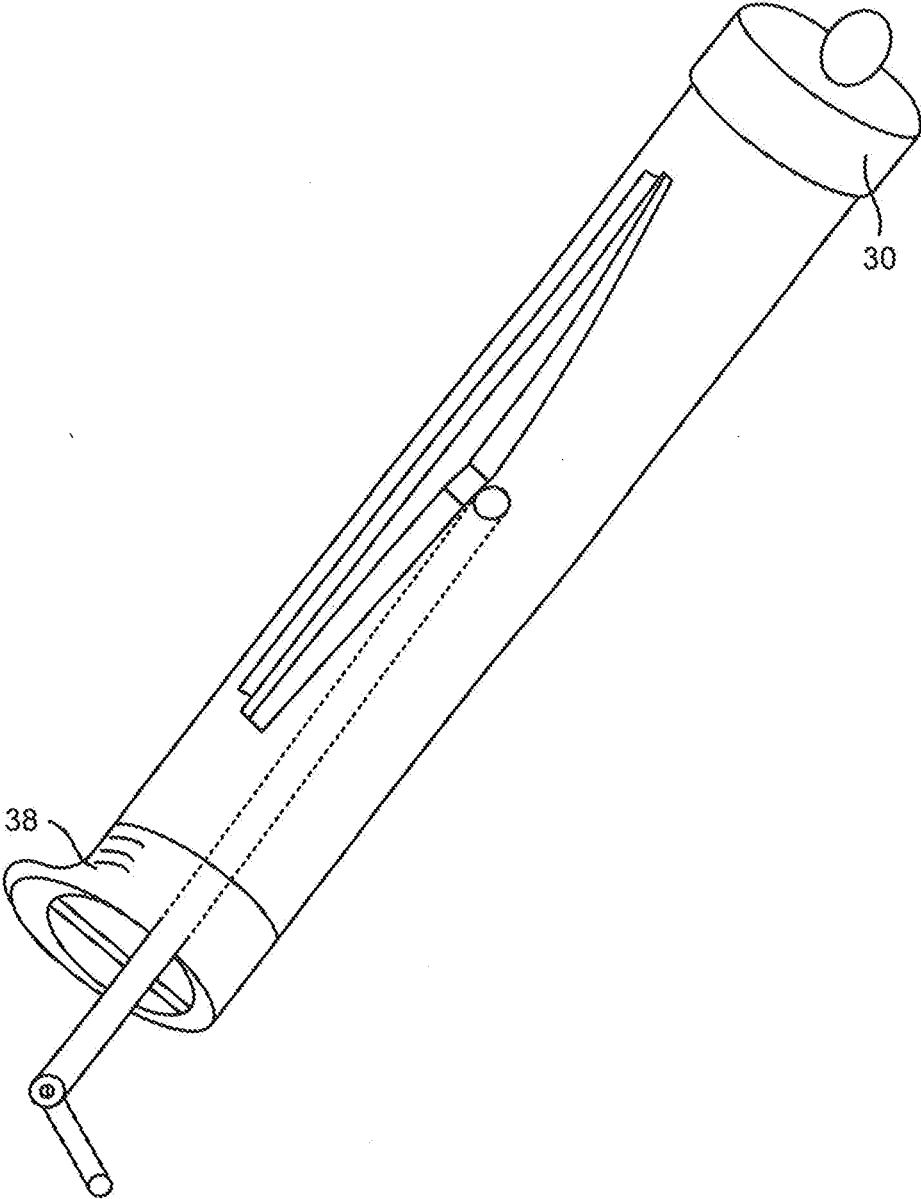

FIG. 5

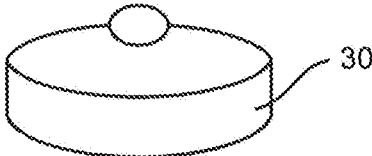

FIG. 6A

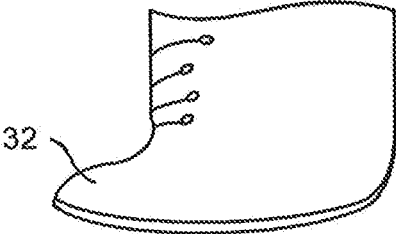

FIG. 6B

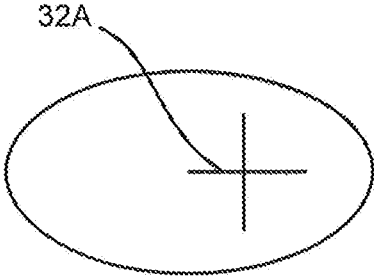

FIG. 6C

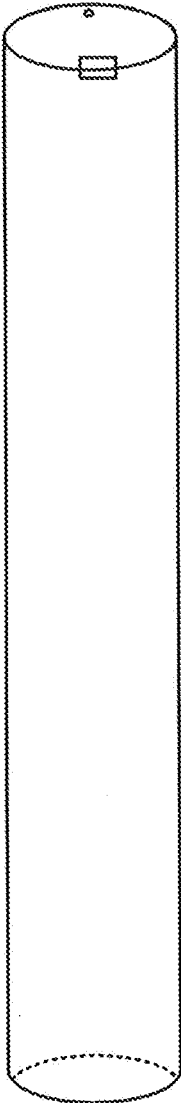

FIG. 6

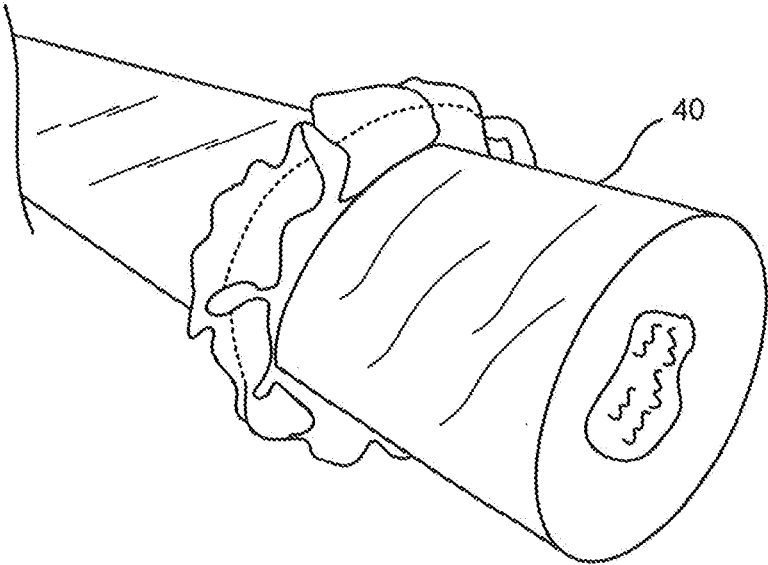

FIG. 7A

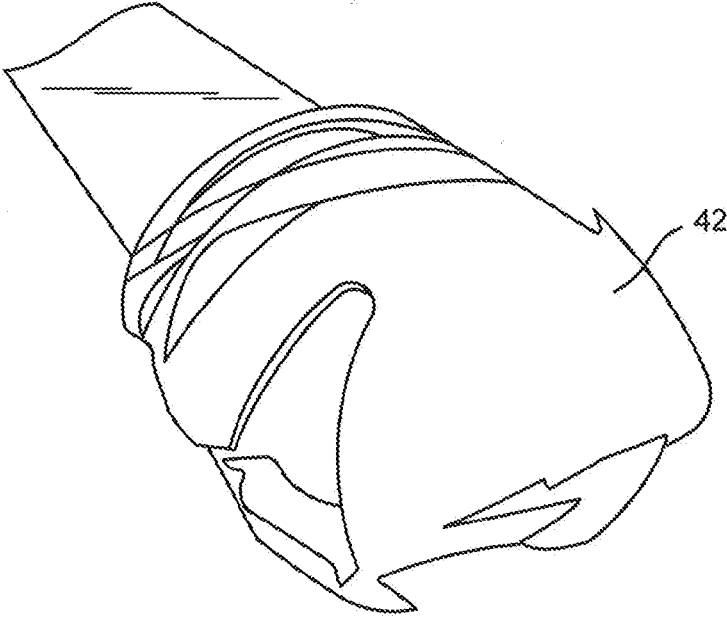

FIG. 7B



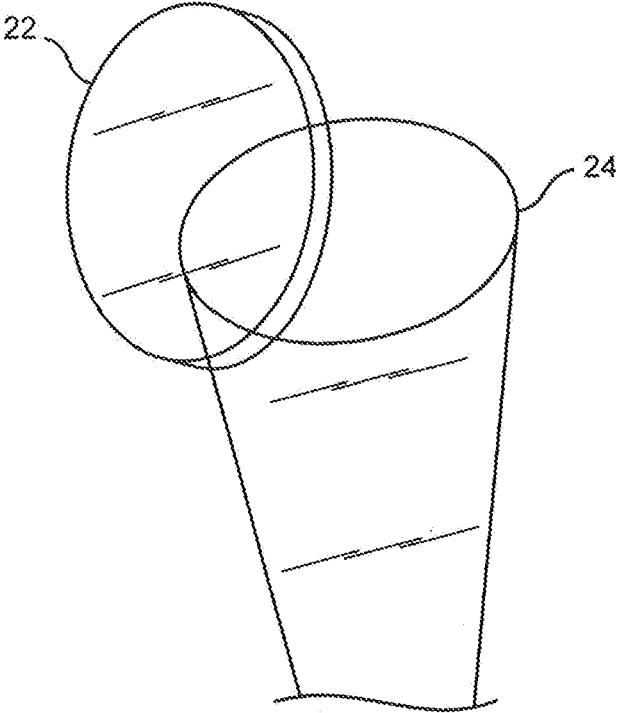

FIG. 8A

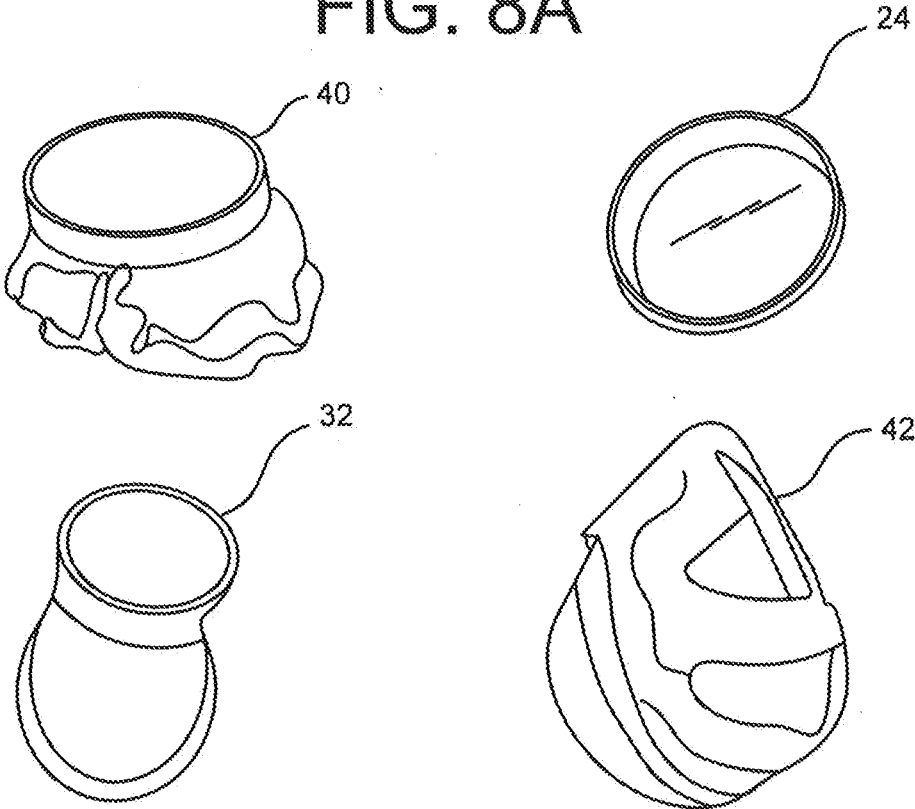

FIG. 8B

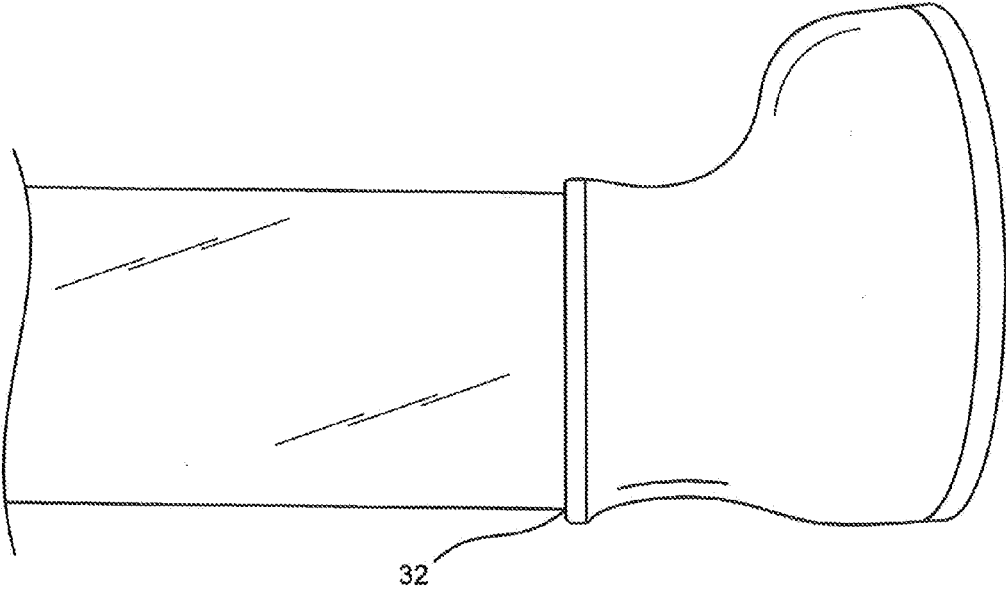

FIG. 9A

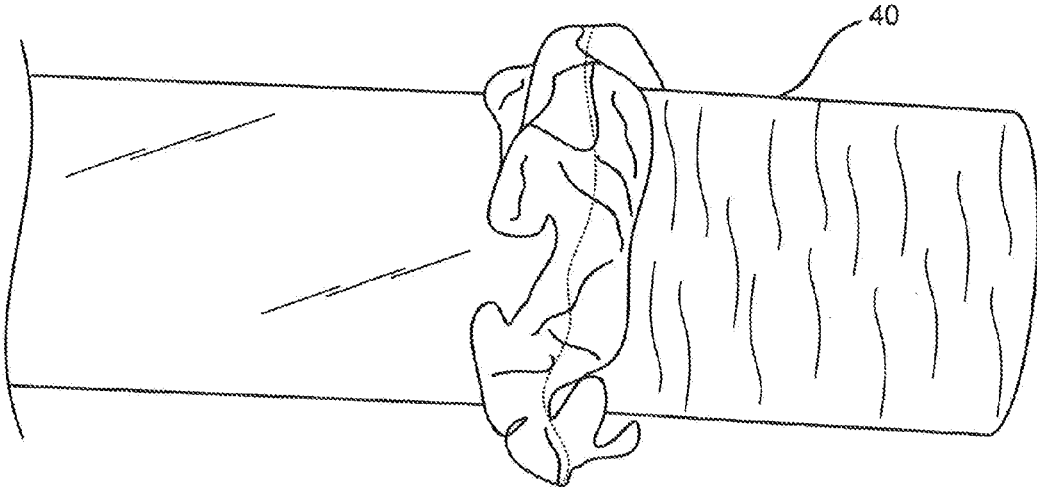

FIG. 9B

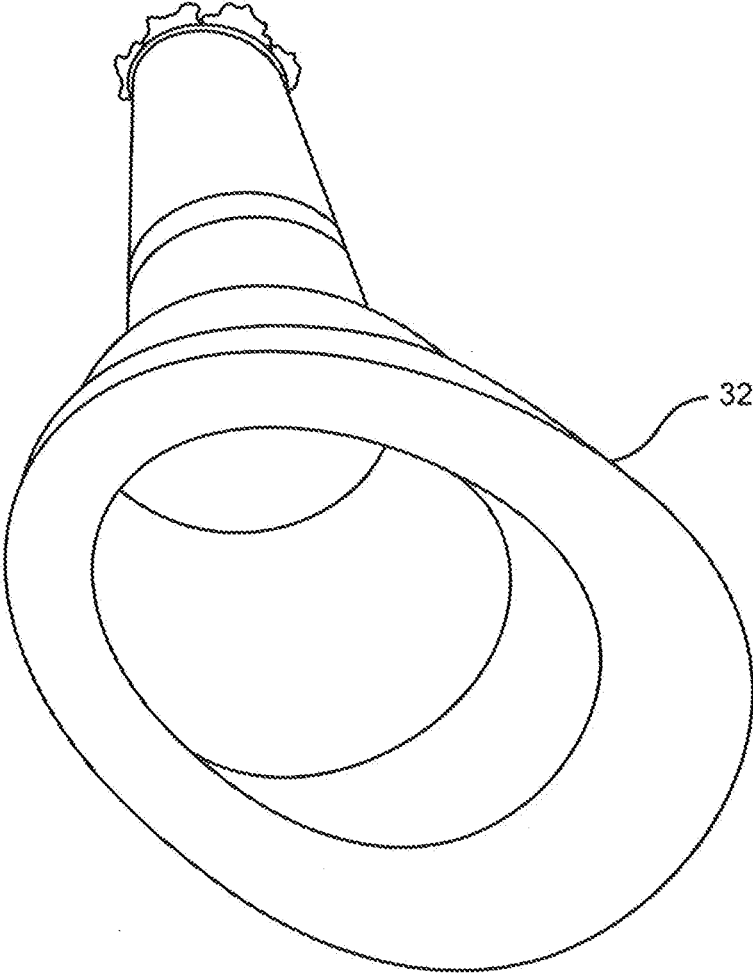

FIG. 10

**WIPER BLADE ASSEMBLY PROTECTOR  
AND METHOD OF PROTECTING A WIPER  
BLADE ASSEMBLY**

RELATED APPLICATIONS

**[0001]** This application claims priority to provisional application Ser. No. 62/275,844 filed Jan. 7, 2016 incorporated herein by reference in its entirety.

BACKGROUND OF THE INVENTION

A. Field of Invention

**[0002]** This invention pertains to a device for protecting the wiper blade assemblies of a motor vehicle during inclement weather, such as ice and snow when motor vehicle ignition is off and the motor vehicle is in a non-operational, parked position.

B. Description of the Prior Art

**[0003]** All motor vehicles on the road today are equipped with windshield wiper devices for cleaning the motor vehicle windshields to remove any materials deposited thereon, such as water, dust, mud, ice, snow, etc. Such devices typically include two components: an arm having one end attached directly or indirectly to a reciprocating shaft disposed just under the windshield and a wiper blade pivotally attached to the opposite end of the arm. Two such arms are disposed below or (in rare occasions, above) the main or front windshield. In addition, some cars, especially high end cars, and suburban utility vehicles (SUVs), may also have at least one wiper on the rear window of the vehicle. These devices are safety devices mandated by the federal government or other authorities.

**[0004]** Importantly, the wiper blades are made of a soft rubber-like material that form a doctoring edge configured to wipe the windshield in a continuous sweeping motion even when the windshield has concave shape. As such, these blades are usually made from a somewhat soft and fragile material because otherwise the blade would not be able to wipe the windshield in a smooth motion without scratching, scoring or otherwise permanently damaging the windshield. A holder is used to mount the blade on the arm. The combination of the arm and blade shall be referred to herein as a wiper blade assembly.

**[0005]** A major problem with existing windshield wipers is that under inclement weather, such as a snow storm, snow falls on the windshield and freezes into a sheet of ice, or a mixture of ice and snow, that covers both the windshield wiper arm and the windshield wiper blade. The ice and frozen snow mix often get packed in a cavity below the full windshield, the same cavity that also holds the wiper arms and blades. Once the wiper arm and wiper blade become embedded lodged in this mix, it is extremely difficult and time consuming to properly dislodge it. Often an operator will prematurely try to engage or activate the wipers while the ice and frozen mix is still present. The torque from the wiper arm causes the wiper arm to become dislodged and break free from the wiper blade at the plastic assembly. This action renders the wiper blade assembly useless until replaced its wiper blade is replaced. Additionally, permanent windshield damage may occur as the bladeless metal arm streaks across the windshield and to the motor driving the arms. Thus, before the vehicle is driven, the ice and snow

must be cleared off both the windshield and the wiper blade assembly. Otherwise, when the windshield wiper is operated, the hard ice on the wiper causes unacceptable and unsafe streaks on the windshield. Moreover, operating the wipers under these conditions can cause damage to the blades to the point where they become unusable and in extreme cases operating any vehicle under these conditions may cause an accident until the blades can be replaced. In other words, the blades can also be easily damaged when one attempts to clean them and remove the frozen ice and snow from them.

**[0006]** Some people try to solve at least some of these problems by leaving the vehicle with the arms snapped into a position, fully away from the windshield at the manufacturer installed wiper arm pivot point. However, this action does not prevent the arm from being damaged.

**[0007]** The present invention provides a cheap, reliable and esthetically pleasing solution to these problems.

SUMMARY OF THE INVENTION

**[0008]** According to this invention, a protector is provided for protecting a windshield wiper assembly having a wiper blade, and an arm turning the wiper blade and the holder, the holder having a blade length. The protector includes tubular body having a body length at least equal to the blade length and defining an internal cavity with at least one opening on one end of said tubular body. A cap is covering the opening, the cap having a flexible cutout configured to selectively receive the wiper blade in said cavity to protect the wiper blade.

**[0009]** Preferably, the body of the protector includes a second cap opposite first cap. Covers are disposed over either one or both of the caps. The covers may include whimsical features or objects, such as caps, socks, protectors, etc. Alternatively, the covers with decorative features are used instead of caps. The cover on the first opening is removable to provide access to said cutout.

**[0010]** In one embodiment, the body has an outer surface with printed material, such logos, or advertisements. The body may be made of a transparent or translucent material.

**[0011]** In one embodiment, a method is presented for protecting the wiper blade assembly. The method includes covering the blade of the assembly with protector when inclement weather is expected, and removing the cover before driving the motor vehicle. Preferably, before the protector is installed, the windshield wiper assembly is pivoted away from the windshield so that the wiper blade is not in contact therefrom. The blade is then inserted into the body opening until it is substantially disposed within the body cavity. The windshield wiper assembly can be left in this pivoted position, or it can be pivoted back against the windshield.

BRIEF DESCRIPTION OF THE DRAWINGS

**[0012]** FIG. 1 shows a car with unprotected windshield wiper blade assembly pivoted in a conventional manner;

**[0013]** FIG. 2 shows the car of FIG. 1 with one of the wipers protected by a sleeve constructed in accordance with this invention;

**[0014]** FIG. 3 shows an isometric view of the blade disposed on the sleeve;

**[0015]** FIG. 4 shows a side view of the sleeve;

[0016] FIGS. 4A-4C show, respectively, an isometric view, a top and a side view of a first bottom cover for the sleeve;

[0017] FIG. 5 shows an isometric view of a sleeve having a top cover in the shape of a hat and a bottom cover in the shape of a protector;

[0018] FIG. 6 shows a side view of the sleeve of FIG. 5;

[0019] FIGS. 6A-6C show, respectively, an isometric view of the top cover, the bottom cover, and a bottom view of the bottom cover.

[0020] FIGS. 7A and 7B show isometric views of a sock used as a top cover and a soft bottom cover;

[0021] FIG. 8A shows a disc shaped top cover;

[0022] FIG. 8B shows isometric views of a sock-shaped cover, a disc-shaped cover, a protector shape bottom cover and a soft bottom cover.

[0023] FIGS. 9A and 9B show side close-up views of the protector-shaped bottom cover and sock shaped top cover.

[0024] FIG. 10 shows a bottom view of an alternate embodiment of the protector cover.

#### DETAILED DESCRIPTION

[0025] FIG. 1 shows an orthogonal view of a typical car 10. It has two windshield wiper assemblies 12, 14 with respective wiper blades 16 (for the sake of clarity, the windshield wiper assemblies 12, 14 are shown enlarged disproportionately to the rest of the car 10). The windshield wiper assemblies 12, 14 are reciprocated so that they move in respective arcs along windshield 18, thereby sweeping off snow, rain, mud, etc. Each assembly includes an arm 19A, having one end 19AA attached to the shaft (not shown) of a motor (not shown) typically disposed below the windshield 18. An arcuate holder 19B is attached to the other end 19BB of arm 18. The holder 19B is used to support a wiper blade 16. The shaft moves the arms 19A and respective holders 19B and blade in an arc as discussed above.

[0026] In addition, assemblies 12, 14 can also be pivoted manually away from the windshield 18 at end 19AA to the positions shown in FIG. 1. As discussed above, when car 10 is not in use, some people pivot the windshield wipers away from the windshield 18 during a snow and/or ice storm. The assemblies 12, 14 are designed and installed by the manufacturer of typical automobiles. Their configuration has been selected to allow an owner to pivot the assemblies and lock securely in place and make room so that the owner can fully clean the windshield 18 and the trench below the windshield used to house the assemblies when not in use. In this manner the owner can then clean the windshield 18 easily without the fear of damaging the wiper blade assemblies 12, 14. Once the windshield 18 is cleaned, the assemblies can be rotated and will snap back to their original, operating position.

[0027] FIG. 2 shows the same car 10 with one of the windshield wiper assembly 12 being provided with a protective protector or protector 20. Once the protector 20 is mounted on the wiper assembly 12 the wiper can be left in the upright pivoted position shown or can be snapped back (the arms are spring loaded) so that the protector 20 rests against the windshield 18. Protector 20 protects the upper portion of the arm 19A, the holder 19B and the blade 16 from the elements. When the protector 20 is removed, the wiper assembly, including and blade 16 are clear of snow and ice and ready to operate.

[0028] As shown in FIGS. 2 and 3, preferably, the protector 20 is formed of a body or sleeve 22 that has a generally tubular shape with a circular or oval cross-section as shown. However, ease in manufacturing or usage may dictate many types of the sleeve 20 shapes. The sleeve 22 can be transparent or translucent or its outer surface 22A can be imprinted with the name of a company for advertising purposes, or with other messages. The sleeve defines a cavity. Preferably, one end of sleeve 22 is closed off by a top cap 24.

[0029] Preferably cap 24 is attached permanently to the sleeve 22 and is water tight to protect the wiper assembly 12. At the opposite end, the sleeve 22 is provided with a second cap or bottom 26. This bottom cap 26 can permanently attached to the sleeve 22 or can be removable (see FIGS. 4, 4A, 4-4C).

[0030] Bottom cap 26 is formed with a cut 28 to provide access to the interior space of the sleeve 22. The cut 28 in one embodiment is cross-shaped. The bottom cap 26 is made of a somewhat flexible material, such as a plastic material to allow portions of the cap 26, especially on flat surface 30 to bend inwardly as the wiper assembly 12 is pushed into the sleeve 22. The functional purpose of bottom cap 26 is to impede snow and ice from entering sleeve 22.

[0031] In one embodiment, various whimsical accessories may be attached to the sleeve to make the protector 20 more attractive and fun to use. The various FIGS. 5-10 show details of some of these accessories. In FIG. 5, 6, 6A-6C the cap 24 or is covered by, or replaced with a knitted hat-like decorative object 30. In addition to the hat-like decorative object 30, a shoe-shaped bottom cover 32 is used on top of, or to replace bottom cap 26. Shoe-like bottom cover 32 is formed with an X-shaped cutout out 32A (See FIGS. 6B, 6C).

[0032] FIG. 7A shows a frilly sock 40 used as a top cover over cap 24 and FIG. 7B shows a frilly bottom cover 42 on end 26.

[0033] FIGS. 8A, 8B shows cap 24 on sleeve 22 with other objects 24, 32, 40, 42 that can be used as top covers. FIGS. 9 and 10 show more pictures of the frilly objects.

[0034] In summary, a protector 20 is provided that includes a sleeve 22, a top cap 24 and a bottom cap 26. The caps can be covered with or replaced by one or more frilly or decorative objects. The sleeve 20 is pulled over the wiper assemblies 12, 14, and more particularly, at least the blade is inserted into the cavity formed by sleeve 20 to protect the assemblies and their respective blades 16 during a snow or ice storm. Preferably the sleeve or body 22 has a body length that is at least equal to the length of the blade to provide protection to the blade.

[0035] A protector 20 is easily and rapidly installed on each wiper assembly 12, 14. After the storm, they can be removed, shaken off and the wiper assemblies 12, 14 can be simply returned to their operational positions, the protectors 20 are stored for use for the next storm.

[0036] In one embodiment, each protector 20 (FIG. 2) is packaged singly or in pairs and sold with, or without a new replacement wiper blade 16 (or a blade 16 and a holder) and decorative accessories.

[0037] In one embodiment, each new/replacement windshield wiper 12, 14 is packaged and sold inside the protector 20. The customer can remove the windshield wiper from the protector 20 by lifting the wiper arm assembly at the pivot arm point 18 (FIG. 2) to secure the wiper arm and wiper

blades away from the windshield and install it on motor vehicles as needed. In one configuration, the outer surface 22A of sleeve 20 can be used to provide the name of the manufacturer of the wiper 12, 14, instructions for installing the wipers, instructions for installing the protector 20, etc., the names of other parties associated with automotive products, or names of entities normally unrelated to automotive products or services.

[0038] Numerous modifications may be made to the invention without departing from its scope as defined in the appended claims.

1-7. (canceled)

8. A method of protecting a windshield wiper assembly including a wiper blade, and an arm selectively reciprocating said wiper blade across the windshield of a motor vehicle, comprising the steps of:

inserting said blade into a protector including a body having a body length at least equal to the length of the wiper blade, said body defining a cavity extending longitudinally through said body and being closed at one end with by a wall with a flexible cut configured to receive said blade into said cavity;

and

removing said protector from said blade to allow said blade to clean the windshield.

9. The method of claim 8 further comprising pivoting said windshield wiper assembly from the windshield so that the wiper blade does not touch the windshield prior to the insertion of the blade into said protector.

10. The method of claim 9 further comprising pivoting said windshield wiper assembly with said protector back to the windshield after the insertion of the blade into the body.

\* \* \* \* \*