



- (51) **International Patent Classification:**  
*B01J 23/745* (2006.01)    *B01J 19/20* (2006.01)  
*C07C 21/06* (2006.01)    *B01J 19/08* (2006.01)
- (21) **International Application Number:**  
PCT/US2012/040070
- (22) **International Filing Date:**  
31 May 2012 (31.05.2012)
- (25) **Filing Language:** English
- (26) **Publication Language:** English
- (30) **Priority Data:**  
61/492,907                    3 June 2011 (03.06.2011)                    US  
13/471,601                    15 May 2012 (15.05.2012)                    US
- (71) **Applicant (for all designated States except US):** HONEYWELL INTERNATIONAL INC. [US/US]; Patent Services M/S AB/2B, 101 Columbia Road, P.O. Box 2245, Morristown, New Jersey 07962-2245 (US).
- (72) **Inventors; and**
- (75) **Inventors/Applicants (for US only):** CLOSE, Joshua [US/US]; Honeywell International Inc., Patent Services M/S AB/2B, 101 Columbia Road, P.O. Box 2245, Morristown, New Jersey 07962-2245 (US). WANG, Haiyou [CN/US]; Honeywell International Inc., Patent Services M/S AB/2B, 101 Columbia Road, P.O. Box 2245, Morristown, New Jersey 07962-2245 (US). TUNG, Hsueh, Sung

[US/US]; Honeywell International Inc., Patent Services M/S AB/2B, 101 Columbia Road, P.O. Box 2245, Morristown, New Jersey 07962-2245 (US). **COTTRELL, Stephen, A.** [US/US]; Honeywell International Inc., Patent Services M/S AB/2B, 101 Columbia Road, P.O. Box 2245, Morristown, New Jersey 07962-2245 (US).

- (74) **Agent:** BEATUS, Carrie; Honeywell International Inc., Patent Services M/S AB/2B, 101 Columbia Road, P.O. Box 2245, Morristown, New Jersey 07962-2245 (US).
- (81) **Designated States (unless otherwise indicated, for every kind of national protection available):** AE, AG, AL, AM, AO, AT, AU, AZ, BA, BB, BG, BH, BR, BW, BY, BZ, CA, CH, CL, CN, CO, CR, CU, CZ, DE, DK, DM, DO, DZ, EC, EE, EG, ES, FI, GB, GD, GE, GH, GM, GT, HN, HR, HU, ID, IL, IN, IS, JP, KE, KG, KM, KN, KP, KR, KZ, LA, LC, LK, LR, LS, LT, LU, LY, MA, MD, ME, MG, MK, MN, MW, MX, MY, MZ, NA, NG, NI, NO, NZ, OM, PE, PG, PH, PL, PT, QA, RO, RS, RU, RW, SC, SD, SE, SG, SK, SL, SM, ST, SV, SY, TH, TJ, TM, TN, TR, TT, TZ, UA, UG, US, UZ, VC, VN, ZA, ZM, ZW.
- (84) **Designated States (unless otherwise indicated, for every kind of regional protection available):** ARIPO (BW, GH, GM, KE, LR, LS, MW, MZ, NA, RW, SD, SL, SZ, TZ, UG, ZM, ZW), Eurasian (AM, AZ, BY, KG, KZ, RU, TJ, TM), European (AL, AT, BE, BG, CH, CY, CZ, DE, DK, EE, ES, FI, FR, GB, GR, HR, HU, IE, IS, IT, LT, LU, LV,

[Continued on next page]

(54) **Title:** METHOD FOR CAPTURING AND RECYCLING IRON CATALYST USED IN THE PRODUCTION OF HALOALKANE COMPOUNDS

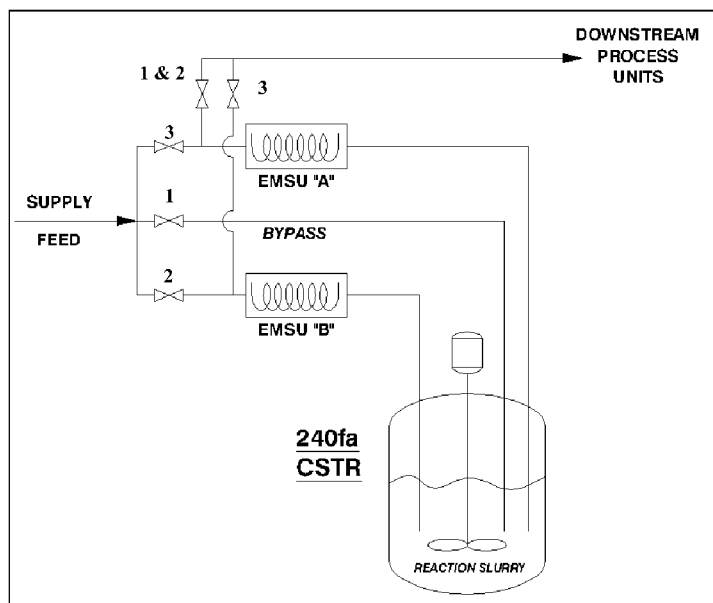

FIGURE

(57) **Abstract:** Disclosed is a method for capturing and recycling iron catalyst used in the production of haloalkane compounds and more particularly, to an improved process for the manufacture of the compound 1,1,1,3,3-pentachloropropane (HCC-240fa), in which an electromagnetic separation unit (EMSU) is used to facilitate the reaction. When energized, the EMSU functions to remove the iron particles from the reactor effluent; when de-energized, the iron particles captured by the EMSU can be flushed back into the reactor for re-use in the continued production of HCC-240fa. The present invention is also useful in the manufacturing processes for other haloalkane compounds such as HCC-250 and HCC-360.



MC, MK, MT, NL, NO, PL, PT, RO, RS, SE, SI, SK, **Published:**  
SM, TR), OAPI (BF, BJ, CF, CG, CI, CM, GA, GN, GQ, — *without international search report and to be republished*  
GW, ML, MR, NE, SN, TD, TG). *upon receipt of that report (Rule 48.2(g))*

- 1 -

## METHOD FOR CAPTURING AND RECYCLING IRON CATALYST USED IN THE PRODUCTION OF HALOALKANE COMPOUNDS

### CROSS-REFERENCE TO RELATED APPLICATION

This application claims domestic priority to commonly owned, copending U.S. Provisional Patent Application Serial No. 61/492,907, filed June 3, 2011, the disclosure of which is hereby incorporated herein by reference.

### FIELD OF THE INVENTION

The present invention relates to a process for the manufacture of haloalkane compounds, and more particularly, to an improved process for the manufacture of the compound 1,1,1,3,3-pentachloropropane (HCC-240fa). The present invention is also useful in the manufacturing processes for other haloalkane compounds such as HCC-250 and HCC-360.

### BACKGROUND OF THE INVENTION

The compound 1,1,1,3,3-pentachloropropane (HCC-240fa) is a raw material for producing 1,1,1,3,3-pentafluoropropane (HFC-245fa), which is a non-ozone depleting

- 2 -

chemical and can be used as blowing agent, energy transfer medium, and so on. Addition reactions for preparing useful haloalkanes, such as HCC-240fa, are known in the art. For example, U.S. Patent No. 6,313,360 teaches a process for producing HCC-240fa by reacting carbon tetrachloride (CCl<sub>4</sub>) and vinyl chloride (VCM) in the presence of a catalyst mixture comprising organophosphate, e.g., tributyl phosphate (TBP), metallic iron and ferric chloride under conditions sufficient to produce a product mixture containing HCC-240fa. The 240fa product is then recovered by separating it from reactants, catalyst and by-products. See also, U.S. Patent Nos. 5,902,914, 6,187,978, 6,198,010, 6,235,951, 6,500,993, 6,720,466, 7,102,041, 7,112,709 and 7,265,082 and U.S. Patent Publication Nos. 2004/0225166 and 2008/0091053. The disclosures of all of these references are hereby incorporated herein by reference.

Iron powder is used as the primary catalyst during the synthesis of HCC-240fa via the coupling reaction between CCl<sub>4</sub> and VCM. The liquid medium, consisting of CCl<sub>4</sub>, TBP, and 240fa, forms a slurry with the iron powder. As such, the reactor effluent will contain a substantial quantity of suspended solids which could potentially upset the mechanical and chemical operations of downstream units. Furthermore, as catalyst is removed from the effluent, the reactivity will suffer, increasing the required make-up of lost iron powder. Hence, there is a need for means by which iron catalyst can be captured and recycled back to reactor. The present invention provides a solution to this problem.

#### SUMMARY OF THE INVENTION

The present invention employs an electromagnetic separation unit (EMSU), configured to allow for the continuous removal of iron particles from reactor effluent and for the recycle of captured iron particles during the catalytic formation of haloalkane compounds from CCl<sub>4</sub> and VCM.

In one embodiment, the present invention can be generally described as a method for capturing and recycling iron catalyst used in the production of 1,1,1,3,3-pentachloro-

- 3 -

propane, in which an electromagnetic separation unit (EMSU) is used to facilitate the reaction. When energized, the EMSU functions to remove the iron particles from the reactor effluent; when de-energized, the iron particles captured by the EMSU can be flushed back into the reactor for re-use.

Thus, one embodiment of the present invention is a method for capturing and recycling iron catalyst during in the production of 1,1,1,3,3-pentachloropropane, comprising the steps of:

- (a) feeding  $\text{CCl}_4$  and VCM into a reactor with a catalyst comprising iron powder and TBP to form HCC-240fa;
- (b) removing the iron particles from the HCC-240fa reactor effluent by employing an energized electromagnetic separation unit (EMSU); and
- (c) denenergizing the EMSU and recycling the iron particles and returning the iron particles to the reactor for re-use in step (a).

The present invention is also useful in the iron catalyzed manufacturing processes for other haloalkane compounds such as HCC-250 and HCC-360:

- (1) HCC-250 may be made from  $\text{CCl}_4$  and ethylene as per the following reaction:

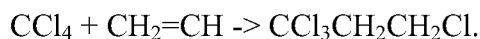

- (2) HCC-360 may be made from  $\text{CCl}_4$  and 2-chloropropene as per the following reaction:

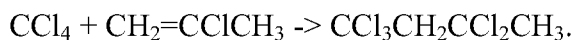

- 4 -

## BRIEF DESCRIPTION OF THE DRAWING

The Figure shows the process setup for the continual removal and recycle of catalytic solids in the production of HCC-240fa and other haloalkane compounds, in a continuous stirred tank reactor (CSTR).

## DETAILED DESCRIPTION OF THE INVENTION

Iron is widely used in many catalyst applications wherein its powder form is suspended in a liquid mixture which would be composed of chemical reactants. Often these slurries are processed continuously and may require careful management of the solids present. Sometimes downstream equipment (i.e., pumps, valves, piping) is unable to handle streams large amounts solid material. Furthermore, undesirable chemistries (separations, side reactions) may exist in the presence of iron. While iron powder is preferred, any iron object can be used, such as iron balls, iron wire, iron shavings, and the like.

Filters are often used and strategically placed to prevent downstream carry-over of solids. However, these filters generally need to be removed from service when they are saturated with iron. As a result, valuable catalyst may be lost and/or process downtime may exist as a result of clean and maintenance of these filters.

The present invention is designed to minimize iron carry-over and process downtime, during the iron catalyzed formation of haloalkane compounds from  $\text{CCl}_4$ , as well as to maximize catalyst retention in a process that employs suspensions of iron solids through the use of one or more electromagnetic separation units (EMSUs). Such devices are commercially available. One commercial manufacturer is Eriez of Erie, PA.

More particularly, the present invention is designed to capture and recycle iron catalyst used in the production of 1,1,1,3,3-pentachloropropane, in which  $\text{CCl}_4$  and VCM

- 5 -

are continuously fed into the reactor at desired ratio and iron powder and the co-catalyst TBP can be added into reactor periodically or continuously. Additional co-catalysts useful herein include the following organophosphate compounds; triphenylphosphate, tributylphosphate, triethylphosphate, trimethylphosphate, tripropylphosphate or any similar organophosphate compound, and mixtures of two or more of these.

The reaction of  $\text{CCl}_4$  and VCM is preferably carried out at a residence time of from about 0.01 hours to about 24 hours, preferably from about 1 hour to about 12 hours. The reaction conditions are judiciously selected for high VCM efficiency, high HCC-240fa yield, and low by-products production. While batch processing can be used for the reactions of the present invention, it is preferred that continuous manufacturing processing is used herein.

In a continuous operation, reactor contents are continually drawn through a tube immersed into the liquid slurry. As the slurry is removed from the reactor, the stream would be prepared by removing iron using an EMSU prior to downstream processing. Although this stream can be processed with a single EMSU, in a preferred embodiment, two (or more) tandem EMSUs are installed and operated in parallel, as shown in Figure 1.

At start-up, valves 1 are opened allowing feed material to prime the 240fa reactor through the bypass and effluent to be directed through EMSU "A". Upon continuous operation, EMSU "A" will be energized. This energized EMSU accepts reactor effluent and operates to capture suspended iron particles. The liquid portion can then continue downstream free of iron. Once EMSU "A" becomes saturated with iron, valves 1 are closed and 3 are opened such that EMSU "B" can accept reactor effluent and begin removing iron.

While the EMSU "B" is operating, the saturated EMSU "A" is de-energized. Reactor supply can then be re-directed through the saturated EMSU "A" such that the

- 6 -

iron catalyst is flushed back into the reactor. As such, a continuous process can be maintained by trading the tasks of each EMSU, either by opening valves 3 when EMSU "A" is saturated or valves 2 when EMSU "B" saturated, to prevent loss of iron to the downstream, maximize catalyst use, and mitigate process downtime.

After going through an EMSU where iron particles are trapped, the reactor effluent stream is flash-distilled to remove a "top" stream including unreacted  $\text{CCl}_4$  and VCM (if any) feed materials and the HCC-240 reaction product, while the catalyst/co-catalyst mixture remains. The distillation may be performed in one or more distillation columns, which are well known in the art.

Preferably, the flash-distillation is conducted in two steps: first, flash-distillation is conducted at a temperature less than the reaction temperature under a pressure, preferably under vacuum, to remove any unreacted  $\text{CCl}_4$  and/or VCM, followed by another vacuum flash-distillation at a lower pressure to remove the HCC-240fa reaction product. The "bottoms" stream is recycled back to the reactor. The distilled, unreacted  $\text{CCl}_4$  and VCM may be recycled back to the reactor. Periodic purges may be applied to avoid accumulation of heavy by-products such as HCC-470 isomers in catalyst recycle stream.

In a later step of the process, the present invention provides for the purification of the crude product by distillation. Fractional vacuum distillation is carried out at about 5 to about 200 mm Hg and a temperature of about  $50^\circ\text{C}$  to about  $150^\circ\text{C}$  to recover the product. It has been discovered that when this purification step is carried out in the presence of an organophosphate compound such as tributylphosphate or other metal chelating compound, the distillation yield of purified product is significantly improved.

While not wishing to be bound by any particular theory, it is believed that the tributylphosphate acts to prevent the decomposition of the HCC-240fa product. Thus, in a preferred embodiment, the purification step includes the addition of an amount of a metal



- 7 -

chelating compound sufficient to improve the HCC-240fa product yield. Preferably, 5 weight percent of tributylphosphate is used.

As used herein, the singular forms "a", "an" and "the" include plural unless the context clearly dictates otherwise. Moreover, when an amount, concentration, or other value or parameter is given as either a range, preferred range, or a list of upper preferable values and lower preferable values, this is to be understood as specifically disclosing all ranges formed from any pair of any upper range limit or preferred value and any lower range limit or preferred value, regardless of whether ranges are separately disclosed. Where a range of numerical values is recited herein, unless otherwise stated, the range is intended to include the endpoints thereof, and all integers and fractions within the range. It is not intended that the scope of the invention be limited to the specific values recited when defining a range.

It should be understood that the foregoing description is only illustrative of the present invention. Various alternatives and modifications can be devised by those skilled in the art without departing from the invention. Accordingly, the present invention is intended to embrace all such alternatives, modifications and variances that fall within the scope of the appended claims.

REMAINDER OF PAGE INTENTIONALLY BLANK

- 8 -

WHAT IS CLAIMED IS:

1. A method for capturing and recycling iron catalyst used during the production of haloalkane compounds from carbon tetrachloride and an alkene by use of an iron catalyst and one or more trialkylphosphate compounds as a co-catalyst, by employing an electromagnetic separation unit (EMSU).
2. The process of Claim 1, wherein the alkene is selected from the group consisting of vinyl chloride, ethylene and 2-chloropropene.
3. The process of Claim 1, wherein the haloalkane compounds are selected from the group consisting of HCC-240fa, HCC-250 and HCC-360.
4. The process of Claim 1, wherein the iron catalyst has a form selected from the group consisting of iron powder, iron balls, iron wire, iron shavings, and mixtures thereof.
5. The process of Claim 1, wherein the co-catalyst is selected from the group consisting of tributylphosphate, trimethylphosphate, triethylphosphate, tripropylphosphate, and mixtures of two or more of these.
6. The process of Claim 1, which is conducted as a continuous operation.
7. The process of Claim 1, which is conducted as a batch operation.
8. The method of Claim 1, wherein two or more energized electromagnetic separation units are employed.
9. The method of Claim 8, wherein the two or more EMSUs are installed in tandem and operated in parallel fashion.

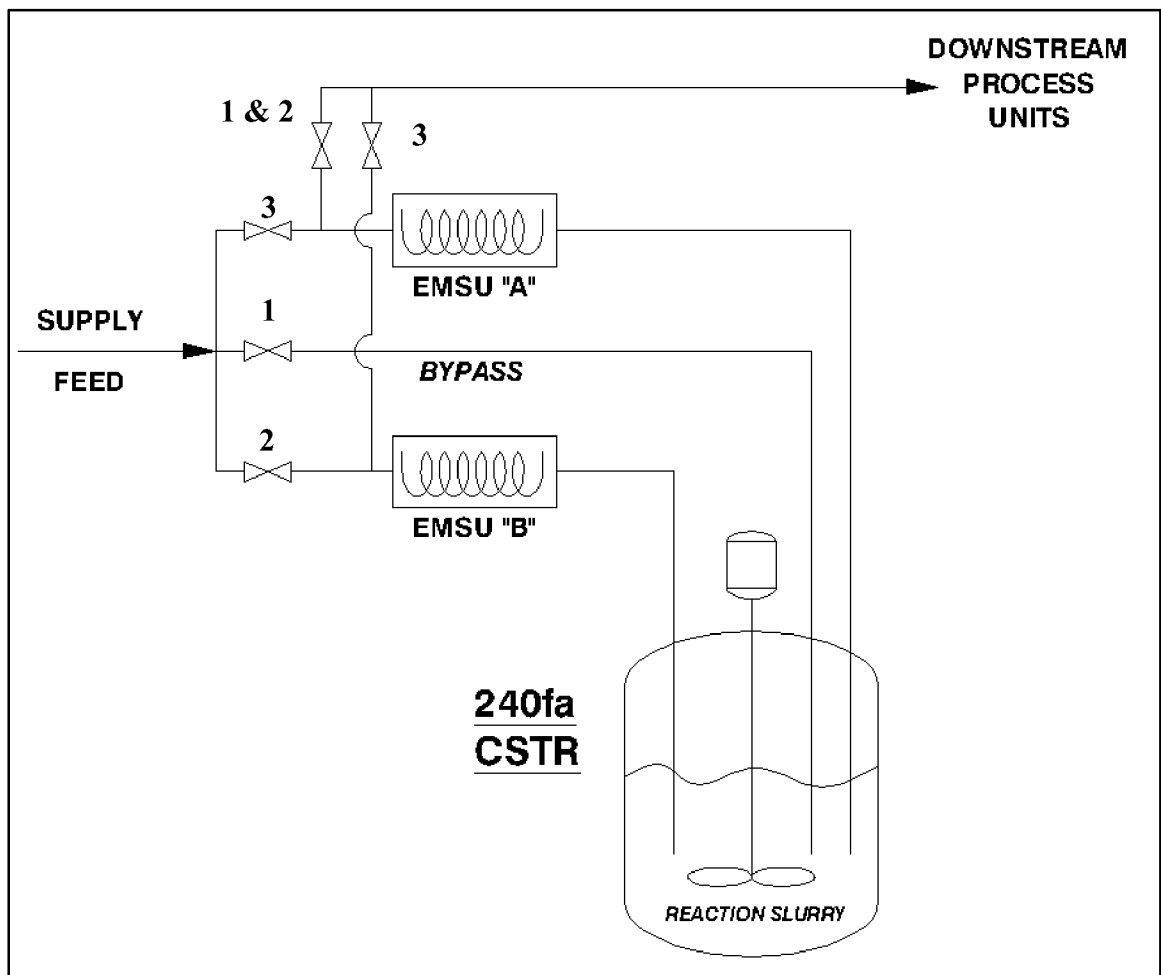

FIGURE