

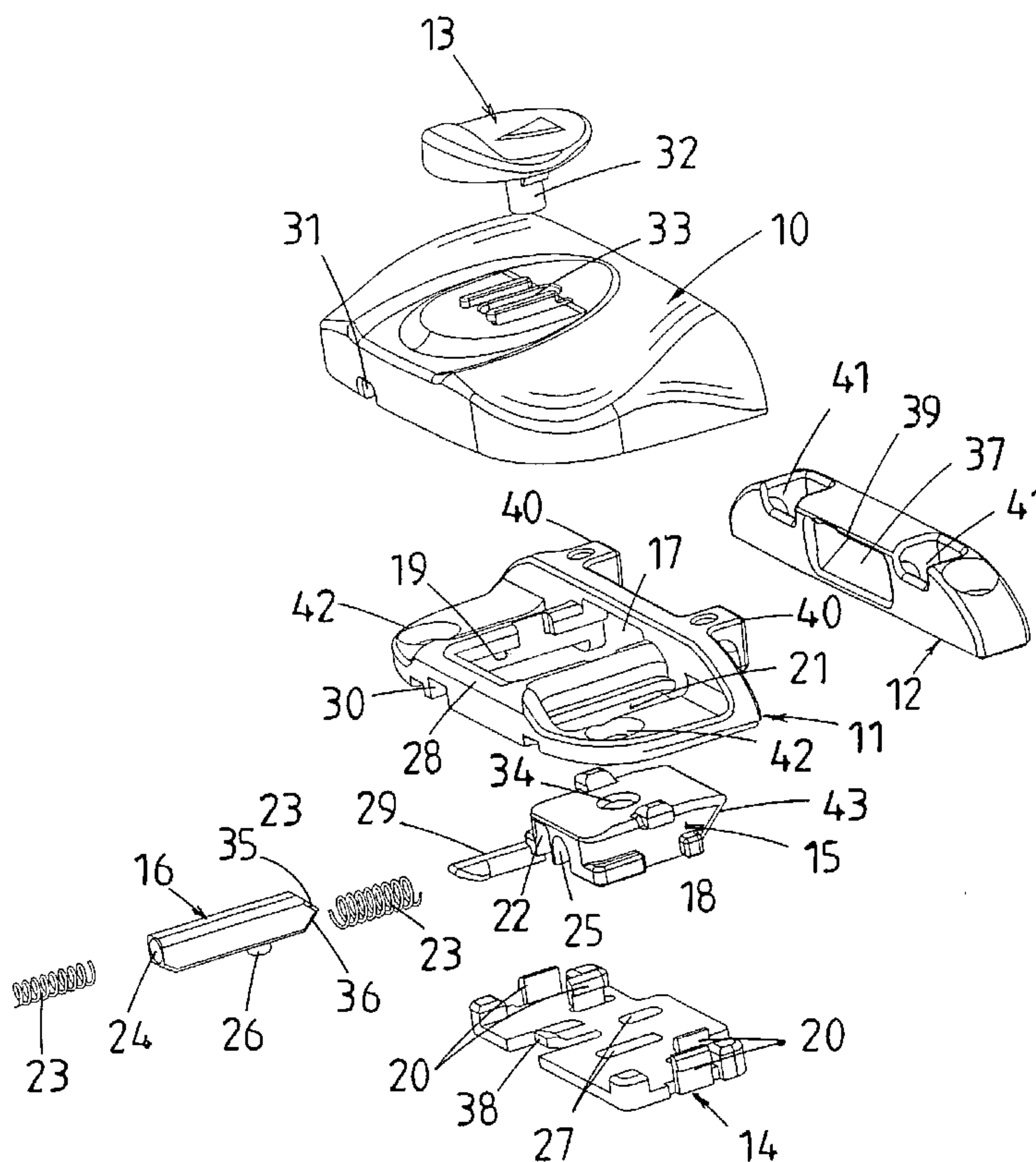

(86) Date de dépôt PCT/PCT Filing Date: 2003/10/24  
 (87) Date publication PCT/PCT Publication Date: 2004/05/06  
 (85) Entrée phase nationale/National Entry: 2005/04/05  
 (86) N° demande PCT/PCT Application No.: NZ 2003/000241  
 (87) N° publication PCT/PCT Publication No.: 2004/038141  
 (30) Priorités/Priorities: 2002/10/24 (522198) NZ;  
 2003/01/23 (523775) NZ

(51) Cl.Int.<sup>7</sup>/Int.Cl.<sup>7</sup> E05C 1/14  
 (71) Demandeur/Applicant:  
 ASSA ABLOY FINANCIAL SERVICES AB, SE  
 (72) Inventeur/Inventor:  
 RICHARDSON, LEIGH, NZ  
 (74) Agent: MARKS & CLERK

(54) Titre : DISPOSITIF A VERROUILLAGE AUTOMATIQUE  
 (54) Title: A SELF-LATCHING DEVICE



(57) Abrégé/Abstract:

A self-latching sash latch device for use with a sliding closure. The latch device has a primary bolt (15) which in use engages with a strike (12). The primary bolt (15) is coupled to an operating element (13) whereby the primary bolt is moveable from a latching position to a retracted position. A retainer (38) retains the primary bolt (15) in the retracted position. A secondary bolt (16) is moveable with or independent of the primary bolt (15) and is engageable with the retainer (38) to release the retainer and enable the primary bolt (15) to move from a retracted position to the latching position.

(12) INTERNATIONAL APPLICATION PUBLISHED UNDER THE PATENT COOPERATION TREATY (PCT)

(19) World Intellectual Property  
Organization  
International Bureau



(43) International Publication Date  
6 May 2004 (06.05.2004)

PCT

(10) International Publication Number  
**WO 2004/038141 A1**

(51) International Patent Classification<sup>7</sup>: **E05C 1/14**

Leigh [NZ/NZ]; 148 Hataitai Road, Hataitai, Wellington (NZ).

(21) International Application Number:

PCT/NZ2003/000241

(74) Agent: **HOPKINS, Donald, Leslie**; C/- Don Hopkins & Associates, Unit 2, Northcote Office Park, 145 Queen Street, Palmerston North 5301 (NZ).

(22) International Filing Date: 24 October 2003 (24.10.2003)

(25) Filing Language: English

(81) Designated States (*national*): AE, AG, AL, AM, AT, AU, AZ, BA, BB, BG, BR, BY, BZ, CA, CH, CN, CO, CR, CU, CZ, DE, DK, DM, DZ, EC, EE, EG, ES, FI, GB, GD, GE, GH, HR, HU, ID, IL, IN, IS, JP, KE, KG, KP, KR, KZ, LC, LK, LR, LS, LT, LU, LV, MA, MD, MG, MK, MN, MW, MX, MZ, NI, NO, NZ, OM, PG, PH, PL, PT, RO, RU, SC, SD, SE, SG, SK, SL, SY, TJ, TM, TN, TR, TT, TZ, UA, UG, US, UZ, VC, VN, YU, ZA, ZM, ZW.

(26) Publication Language: English

(30) Priority Data:

522198 24 October 2002 (24.10.2002) NZ  
523775 23 January 2003 (23.01.2003) NZ

(71) Applicant (*for all designated States except US*): **ASSA ABLOY FINANCIAL SERVICES AB** [SE/SE]; Klarabergsviadukten 90, S-107 23 Stockholm (SE).

(84) Designated States (*regional*): ARIPO patent (GH, GM, KE, LS, MW, MZ, SD, SL, SZ, TZ, UG, ZM, ZW), Eurasian patent (AM, AZ, BY, KG, KZ, MD, RU, TJ, TM), European patent (AT, BE, BG, CH, CY, CZ, DE, DK, EE, ES, FI, FR, GB, GR, HU, IE, IT, LU, MC, NL, PT, RO,

(72) Inventor; and

(75) Inventor/Applicant (*for US only*): **RICHARDSON,**

[Continued on next page]

(54) Title: A SELF-LATCHING DEVICE

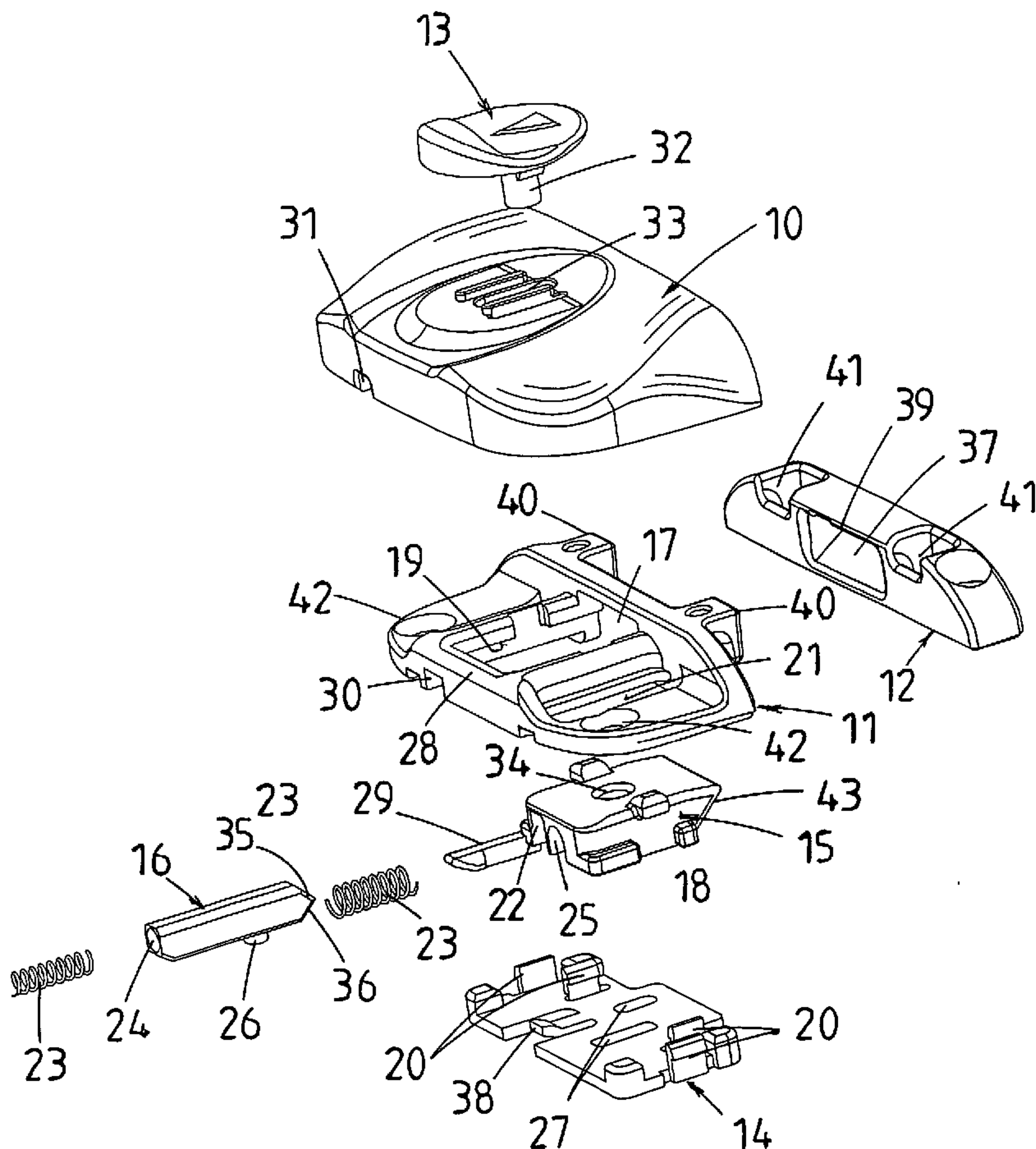

(57) Abstract: A self-latching sash latch device for use with a sliding closure. The latch device has a primary bolt (15) which in use engages with a strike (12). The primary bolt (15) is coupled to an operating element (13) whereby the primary bolt is moveable from a latching position to a retracted position. A retainer (38) retains the primary bolt (15) in the retracted position. A secondary bolt (16) is moveable with or independent of the primary bolt (15) and is engageable with the retainer (38) to release the retainer and enable the primary bolt (15) to move from a retracted position to the latching position.

WO 2004/038141 A1

**WO 2004/038141 A1**



SE, SI, SK, TR), OAPI patent (BF, BJ, CF, CG, CI, CM, GA, GN, GQ, GW, ML, MR, NE, SN, TD, TG).

*For two-letter codes and other abbreviations, refer to the "Guidance Notes on Codes and Abbreviations" appearing at the beginning of each regular issue of the PCT Gazette.*

**Published:**

— *with international search report*



**TITLE OF THE INVENTION****A SELF-LATCHING DEVICE**

5

**BACKGROUND TO THE INVENTION**

This invention relates to a latch device and more particularly one which is self-latching. The latch device is primarily intended for the latching of a sliding window sash  
10 in the closed position in a window frame.

Currently there are a number of self-latching window sash latches available on the market. In most cases the latch operates after the window has been physically closed. Thus  
15 when the latch has reached the same level as the strike it latches the window in the closed position. To open the window an operating member e.g. a pull lever is operated and is held in the "open" position until such time as the latch has been lifted or slid past the strike. The operating  
20 member is then released.

One problem with this type of latch device arises when disengaging the latch from the strike. As described above the action of opening the window involves holding the  
25 operating member and at the same time physically lifting or moving the window. Not only is this action awkward to perform but also it can be very difficult to perform on large windows, windows without finger grips, windows with more than one latch and windows which have limited/restricted access.

30

A second problem is related to security and safety. With known latches there is no indication once the window sash has

been moved to its fully closed position as to whether the latch has in fact successfully engaged with the strike. Thus a window thought to be latched may, in fact, be unlatched which can give rise to potential safety and security risks.

5

#### SUMMARY OF THE INVENTION

An object of the present invention is thus to provide a sash latch device that self-latches when the window sash is moved to the closed position.

10

A further object of the present invention is to provide a sash latch device which self-latches and provides an indication if the latch has not completely self-latched.

15

It is yet a further object of the present invention to provide a sash latch device, which permits the latch to be activated such that after activation the user can use both hands to pull or slide the window sash into an open position.

20

Broadly according to one aspect of the invention there is provided a sash latch device of a self-latching type including a primary bolt for, in use, engagement with a strike, the primary bolt being coupled to an operating element whereby the primary bolt is moveable from a latching position to a retracted position, retaining means to retain the primary bolt in the retracted position and an activation means operable to release the retaining means to enable the primary bolt to move from the retracted position to the latching position.

25  
30

Broadly according to a second aspect of the invention there is provided a self-latching sash latch device including a latch body having a primary bolt, a strike, the primary bolt being mounted for movement in said body between a latching position where, in use, the primary bolt engages in a latching configuration with the strike and a retracted position, and an operating element operatively coupled to the primary bolt to enable the primary bolt to be moved from the latching position to the retracted position, a retaining means to retain the primary bolt in the retracted position and a release member moveable with or independent of the primary bolt to effect release of the retaining means to release the primary bolt and enable it to move from the retracted position to the latching position.

15

Preferably the latch includes an indicator element which projects from the latch to indicate that the primary bolt is not in its latching position.

20

#### **BRIEF DESCRIPTION OF THE DRAWINGS**

In the following more detailed description of the present invention in its preferred forms, reference will be made to the accompanying drawings in which:-

25

Figure 1 is a perspective view of the latch device according to a first embodiment of the invention,

30

Figure 2 is a front elevation view of the latch device shown in Figure 1,



Figure 3 is an exploded perspective view of the latch device in Figures 1 and 2,

5 Figure 4 is a top perspective view of the first embodiment of the latch device with the cover removed and the latch device in the closed position with a strike,

10 Figure 5 is an underside view of the arrangement shown in Figure 4,

15 Figure 6 is a cross sectional view of the latch device according to the first embodiment when mounted with a section of a window sash,

Figure 7 is an exploded view of a second embodiment of the latch device,

20 Figure 8 is a sectional view of the second embodiment,

Figure 9 is an underside view of the second embodiment but with the base removed,

25 Figure 10 is an underside view of a third embodiment of the latch device according to the invention, the latch being in the "locked" position,

30 Figure 11 is a view similar to Figure 10 but showing the latch in the "unlocked" position, and

Figure 12 is a view similar to views 10 and 11 but showing a fourth embodiment with the latch in the "locked" position.

5     **DESCRIPTION OF PREFERRED EMBODIMENTS OF THE INVENTION**

The sash latch device according to the present invention includes a cover 10 of suitable plastic or die cast zinc construction. The cover 10 is able to be mounted onto a  
10 chassis 11 in e.g. a slide dip fashion. The chassis 11 is preferable of die cast zinc construction.

A latch element, as hereinafter described, is engageable with a strike 12. A button 13 or operating member is provided  
15 with cover 10 for operation of the latch element. The latch device further includes a base 14, which in the preferred form is plastic.

According to the present invention the latch element comprises a primary bolt 15 and a secondary bolt 16. These  
20 components can be made from a suitable plastic or metal.

The primary bolt 15 is located in an opening 17 in the chassis 11 such that projecting edges 18 of the primary bolt 15 slidably engage with shoulders 19 at each side of opening  
25 17. The primary bolt 15 is held in place in the chassis 11 by a base 14. The base 14 preferably clip mounted onto the chassis 11 by two pairs of spring clips 20 which, as shown in e.g. Figure 4, clip over opposed edges of an aperture 21 in the chassis 11.

30 The primary bolt 15 has a passageway 22 in which the secondary bolt 16 is slidably engaged. A pair of springs 23



and 23a are provided for biasing the primary bolt 15 and the secondary bolt 16 to a "projecting" or latching position. One end of a spring 23 is located in a bore 24 in the secondary bolt 16. The other spring 23 is located in a  
5 recess 25 in the primary bolt 15.

Each of primary bolt 15 and secondary bolt 16 have a projecting lug 26 and 26a respectively, which slidably engage in respective slots 27 and 27a in the floor of base  
10 14. Thus with the secondary bolt 16 located in passageway 22 of the primary bolt 15 and the primary bolt 15 held in position in opening 17 in the chassis 11, by the clip fastening of base 14 to the chassis 11 the free ends of the springs 23 and 23a engage against a surface formed by wall  
15 28 of the chassis 11. The primary and secondary bolts 15/16 are thus always biased to a projecting position (see for example Figure 5) as will hereinafter become apparent.

Attached to or forming part of the primary bolt 15 is an  
20 indicator 29. This is an elongate member which is slidably engaged through an opening 30 in wall 28. Opening 30 is aligned with an opening 31 in cover 10 when the cover 10 is clipped onto the chassis 11.

25 The button 13 has a downwardly projecting spigot 32 which engages through an elongate slot 33 in the top of the cover 10. Spigot 32 engages in an opening 34 in the primary bolt 15.

30 In use, the chassis 11 (after primary/secondary bolts 15/16 and base 14 have been clipped into place) is fastened to a section of a window sash S. This is achieved by mechanical

fasteners such as screws, bolts etc. engaging through openings 42 in the chassis 11. Once the chassis 11 has been fastened into place the cover 10 is clipped over the chassis 11 which results in the button 13 engaging with the primary  
5 bolt 15.

In a conventional manner, the strike 12 is mounted to another section which forms the opposing part of a sash or window frame as the case may be. In Figure 6 the strike 12 is shown  
10 fastened to a part of a fixed window frame W though equally in a double sliding sash arrangement the strike 12 would be fitted to the second sash.

To further describe the invention the latch and its  
15 associated strike 12 are considered to be mounted to the sash S and frame W with the primary bolt 11 projecting into the strike 12 (see for example Figure 6). Because of the presence of the wall 39 or overhang of the strike 12 sash S is not able to move relative to frame W. However, if a sliding  
20 action is applied to the push button 13 so that it moves in the direction of arrow A (see Figure 6) the primary bolt 15 will be moved so that the beak portion 43 of primary bolt 15 clears the wall 39. This means that the beak 43 of the primary bolt 15 moves out of the cavity 37 in the strike 12.

25

This movement, however, also results in the secondary bolt 16 engaging a trigger clip 38 to thereby release the primary bolt 15. As shown in Figure 3 trigger clip 38 is formed as an integral part of base 14 and extends on an upward incline  
30 to a distal or terminal end. Consequently, the primary bolt 15 moves back to its projecting position in preparation for self-latching with the strike when the window is closed.



When the primary bolt 15 is moved in the direction of arrow A it comes into engagement with the trigger spring clip 38 in the base 14. As a result the primary bolt is held in the retracted position. This therefore enables the user to use  
5 both hands to cause the sash S to be moved relative to the frame W.

The secondary bolt 16 has a double inclined leading edge formed by oppositely inclined surfaces 35 and 36. When  
10 primary bolt 15 is retracted the secondary bolt still protrudes into cavity 37. However, as the sash S is opened surface 35 of the secondary bolt 16 contacts the edge of wall 39. This causes the secondary bolt 16 to be pushed back into the primary bolt 15 for a distance sufficient to enable the  
15 secondary bolt 16 to clear the strike 12.

When the window is moved back to the closed position the leading surface 36 of secondary bolt 16 comes into engagement with wall 39. This causes the secondary bolt 16 to be moved  
20 (in the direction of arrow A) relative to primary bolt 15. In the event that the primary bolt 15 has been held in the retracted position (by someone holding the primary bolt 15 when opening the window) the movement of secondary bolt 16 results in secondary bolt engaging with the trigger clip 38.  
25 This activates the clip to cause release of the primary bolt 15.

The beak 43 can thus contact the edge of wall 39 such that when the sash is moved to the fully closed position the beak  
30 may enter the cavity 37. The latching device therefore self-latches when the latch reaches the same level as the strike.



Consequently during both opening and closing of the window the secondary bolt 16 can cause release of the primary bolt. This ensures that the primary bolt 15 will always self latch.

5 As shown in the drawings the chassis 11 also has a pair of protrusions 40 which are parallel and spaced apart. These correspond in position with two cavities 41 one of which is located either side of the main cavity 37 of strike 12. As the window S is closed these protrusion 40 (whose geometry is  
10 such as to accommodate window tolerance variance) come into contact with the corresponding cavities 41 in the strike 12. They thereby align the latch to the strike in the horizontal, vertical and lateral planes.

15 Referring now to Figures 7, 8 and 9 a second embodiment of the latch device is illustrated. This embodiment of the invention incorporates an anti-tamper feature which prevents the primary bolt 15 from being forcibly retracted through manipulation from outside of the dwelling (i.e. the bolt  
20 being pushed back from striking engagement by use of a blade etc.). According to this embodiment of the invention the button 13 must be used in order for the latch to be moved to an unlocked position.

25 The anti-tamper feature includes an anti-tamper clip 43 which is situated in the base 14. As the base 14 is in the preferred form of plastic construction the anti-tamper clip 43 can be integrally formed with the base 14. The anti-tamper clip 43 has the function of preventing the primary  
30 bolt 15 from retracting. This is achieved by the distal end 43' of the clip 43 engaging against edge 44 of the primary bolt 15.

In this form of the invention the button 13 which is clipped into cover 10 and is slidably moveable has a profiled or sloping end 45 on the spigot 32. The spigot 32 engages in an opening in the primary bolt 15 as previously described but in this embodiment the opening 34' is elongate. Consequently a lost motion in bolt 15 is achieved. Thus if the primary bolt 15 is tampered with the bolt will slide back and engage with the anti-tamper clip 43 but the button 13 will not move because of the lost motion.

The anti-tamper clip 43 is moved out of the way of the primary bolt 15 by the profiled end 45 of the button 13 sliding over the clip 43 hence pushing the clip clear of the primary bolt. The button 13 then continues to retract the primary bolt 15 in the normal manner.

In the form of the invention as illustrated the primary bolt 15, if forced back by external manipulation, moves approximately 1.5mm before it is stopped by the anti-tamper clip 43. As indicated above the button 13 does not move during this movement of the primary bolt 15. As a result there is no "redundant" travel of the button 13 during normal operation. Therefore, the anti-tamper feature is not readily discernable to the user as it is a feature which only comes into effect if attempts are made to forcibly open the latch from the outside.

It is believed that the present invention addresses the problems previously identified and associated with known self-latching window sash latches. It achieves these objectives as follows:-

- The action to disengage the latch from the strike is a "once-off" finger motion which results in the sliding movement of the button 13. Once this motion is completed the primary bolt 15 is held in the retracted position which, therefore, allows the user to remove his or her hands from the latch without the primary bolt 15 re-engaging in the strike 12. The user therefore has both hands free to open the window sash.

10

- The latch provides clear visual indication of whether the strike has been successfully engaged. Thus if the indicator 29 is protruding from opening 31 in cover 10 this is an indication that the primary bolt 15 has not moved back to its fully projecting position i.e. has not fully latched. The indication is visible from a distance and allows a user to quickly assess if the window is secure.

15

- The latch according to the present invention provides the above identified features without introducing additional steps to its operation. It retains all the benefits of a self-latching latch while providing features not normally available with self-latching latch devices.

20

25

The combination of self-latching, indication and hands free operation is achieved by having the secondary bolt, the trigger spring clip 38 and primary bolt 15 all dependant on each other for timing, position and overall function. This, however, is achieved in a straight forward and operationally effectively manner.

30



As disclosed herein the present invention can incorporate an indicator, which indicates whether the latch is in the locked or unlocked position. Currently there are a number of window hardware products available on the market and some of these  
5 have a method of indicating if the window is latched or not. These however suffer from deficiencies which include one or more of the following, namely, the need for additional parts (which leads to additional cost both in parts and assembly), not clear contrast between open and closed,  
10 difficulty in ascertaining if a latch is partially open or closed and the indicator being visible from outside the window (which can result in a security risk).

In a further version of the present invention as shown in  
15 Figures 10-12, the invention provides an indicator which does not require additional components, is clear and obviously open or shut and cannot be seen from outside the window. The indicator therefore deals with the deficiencies associated with currently known indicators.

20

As shown in Figure 10, the base 14 has moulded into it, two legs 51 which are located spaced apart and side by side. The shape and thickness of these legs 51 is designed so that the legs act like hinged springs. The distal ends of the legs 51  
25 have integrally moulded therewith flaps 52. As can be seen in Figure 10, these flaps 52 obstruct the opening 31 in the cover 10.

As previously disclosed, the primary bolt 15 has a protrusion  
30 53 extending from the back of it. In one form of the invention the protrusion 53 is moulded as part of the primary bolt 15.

When the primary bolt 15 is disengaged from the strike 12, the protrusion 53 pushes its way through the flaps 52 so that the distal end 54 of the protrusion 53 shows (with  
5 contrasting colour) through the window 31. The design of the legs 51 and the protrusion 53 ensure that the flaps 52 open very quickly, because the flaps are either side of the protrusion 53 and the hinge in a plane perpendicular to the direction of movement of the protrusion. As a consequence,  
10 there is nearly instant colour contrast between the distal end 54 of the protrusion 53 and the surrounding material of the cover 10.

The indicator does not require additional components as the  
15 features are incorporated as part of existing components of the self-latching lock. Because the protrusion is designed to minimise time from open to closed and vice versa, it is easy to identify whether the lock is latched or not. Because the indicator is positioned at the front side (facing  
20 internally of the latch) it makes it very difficult to see from outside the window, thus, the indicator is not readily visible, which if it were, could result in a security risk.

Figure 12 shows a different version of the arrangement shown  
25 in Figures 10 and 11. According to this version, the legs 51 are no longer attached at one end and free at the other. Legs 51 are, as can be seen from Figure 12, attached to the base 14 about two-thirds of the way down the length of the leg.

30

A further difference is that the protrusion 53 still retains a knob 54 at its extreme or distal end. However, it

additionally has a wider extended knob 55 at the base of the protrusion.

5 According to this arrangement, the legs have a pivotal hinging point rather than a just one hinge. This allows the knob 54 at the distal end of the protrusion 53, to open the flaps 52 and the legs 51 in the "bolt retraction stroke". However, on the "bolt engagement stroke" the knob 55 contacts the legs 51 in the area 56 below the pivot point 57, thereby  
10 closing the legs 51 and hence flaps 52.

The advantage of using this arrangement is that the indicator is not reliant on the memory or spring of the plastic to close the flaps (the hinge may deteriorate over time and  
15 return the flaps to the closed position, leaving them partially opening and thereby reducing the effectiveness of the indicator). The protrusion 54 opens and closes the flaps 52 mechanically every time, thereby ensuring the flaps are positively opened or closed.

20



**CLAIMS:**

1. A sash latch device of a self-latching type including a primary bolt for, in use, engagement with a strike, the primary bolt being coupled to an operating element whereby the primary bolt is moveable from a latching position to a retracted position, retaining means to retain the primary bolt in the retracted position and an activation means operable to release the retaining means to enable the primary bolt to move from the retracted position to the latching position.
2. A latch device as claimed in claim 1 wherein the activation means is a secondary bolt moveably carried by the primary bolt.
3. A latch device as claimed in claim 2 wherein the primary bolt is biased by biasing means to move to the latching position.
4. A latch device as claimed in claim 3 wherein the secondary bolt includes an engagement surface which, in use, is engageable with an abutment surface whereby the secondary bolt moves relative to the primary bolt to cause the retaining means to move to a release position.
5. A latch device as claimed in claim 4 wherein the secondary bolt includes a second engagement surface which, in use, is engageable with an abutment surface to cause the secondary bolt to move and cause the retaining means to move to the release position.

6. A latch device as claimed in claim 4 or 5 in combination with a strike wherein the abutment surface is formed by at least one surface of a wall of the strike.

5 7. A latch device as claimed in any one of claims 2 to 6 wherein the secondary bolt is slidingly located in the primary bolt.

10 8. A latch device as claimed in any one of claims 1 to 7 wherein the primary bolt is slidingly mounted in a chassis which is removably coupled to a base.

9. A latch device as claimed in claim 8 further including a cover removably mounted to the chassis.

15

10. A self-latching sash latch device including a latch body having a primary bolt, a strike, the primary bolt being mounted for movement in said body between a latching position where, in use, the primary bolt engages in a latching configuration with the strike and a retracted position, and an operating element operatively coupled to the primary bolt to enable the primary bolt to be moved from the latching position to the retracted position, a retaining means to retain the primary bolt in the retracted position and a release member moveable with or independent of the primary bolt to effect release of the retaining means to release the primary bolt and enable it to move from the retracted position to the latching position.

20

25

30

11. A latch device as claimed in claim 10 wherein the primary bolt is mounted for sliding movement between the

latching and retracted positions and the release member is a secondary bolt mounted with the primary bolt such that movement of the secondary bolt relative to the primary bolt can occur.

5

12. A latching device as claimed in claim 11 wherein the secondary bolt has a leading end which has a first engagement surface which is exposed for contact with a part of the strike when the primary bolt is moved to the retracted position by the operating element, whereby contact between the first engagement surface and said part of the strike during relative movement between the body and strike causes the secondary bolt to move to the position where it effects release of the retaining means.

10

15

13. A latch device as claimed in claim 12 wherein the first engagement surface is a surface, which is inclined relative to the direction in which the secondary bolt is moveable.

20

14. A latch device as claimed in claim 12 or 13 wherein said strike has a wall which overlaps an engagement portion of the primary bolt when the primary bolt is in the latching position and the latch device is in a latching configuration.

25

15. A latch device as claimed in claim 12, 13 or 14 wherein the secondary bolt has a second engagement surface which is engageable with said part of the strike upon relative movement between the body and strike occurring in an opposite direction.

30



16. A latch device as claimed in any one of claims 10 to 15 wherein the primary bolt and the release means are independently biased by separate biasing means.
- 5
17. A latch device as claimed in any one of claims 10 to 16 wherein the retaining means is a spring clip engageable with an abutment of the primary bolt.
- 10 18. A latch device as claimed in claim 17 wherein the release member is moveable to a position where it moves the spring clip out of engagement with the abutment to thereby release the retaining means.
- 15 19. A latch device as claimed in any one of claims 1 to 18 further including limiting means engageable with the primary bolt when in the latching position.
- 20 20. A latch device as claimed in claim 19 further including limit release means operable by the operating element to release the limiting means to free the primary bolt for movement from the latching position to the retracted position.
- 25 21. A latch device as claimed in any one of claims 1 to 20 further including indicator means moveable in response to movement of the primary bolt to provide an indication visually apparent from externally of the body of the latch device being in a latching or non-latching
- 30 configuration.

22. A latch device as claimed in claim 21 wherein the indicator means comprises an elongate member with a distal end slidably engaged in an opening in an external surface of the body.

5

23. A latch device as claimed in claim 22 wherein there is further provided one or more cover elements to cover the opening but moveable to enable said distal end to become visible.

10

24. A latch device as claimed in claim 23 wherein the cover elements comprise a pair of flaps carried by legs, the legs being moveable apart by movement of the elongate member to cause the flaps to move away from covering the opening.

15

25. A latch device as claimed in claim 22, 23 or 24 wherein the distal end includes a knob.

20

26. A self-latching sash latch device substantially as herein described with reference to Figure 1 to 6 or Figures 1 to 9 of the accompanying drawings.

25

27. A self-latching sash latch device as claimed in claim 26 with further reference to Figures 10 and 11 or Figure 12 of the accompanying drawings and the associated description of Figures 10 and 11 or Figure 12.

1/7

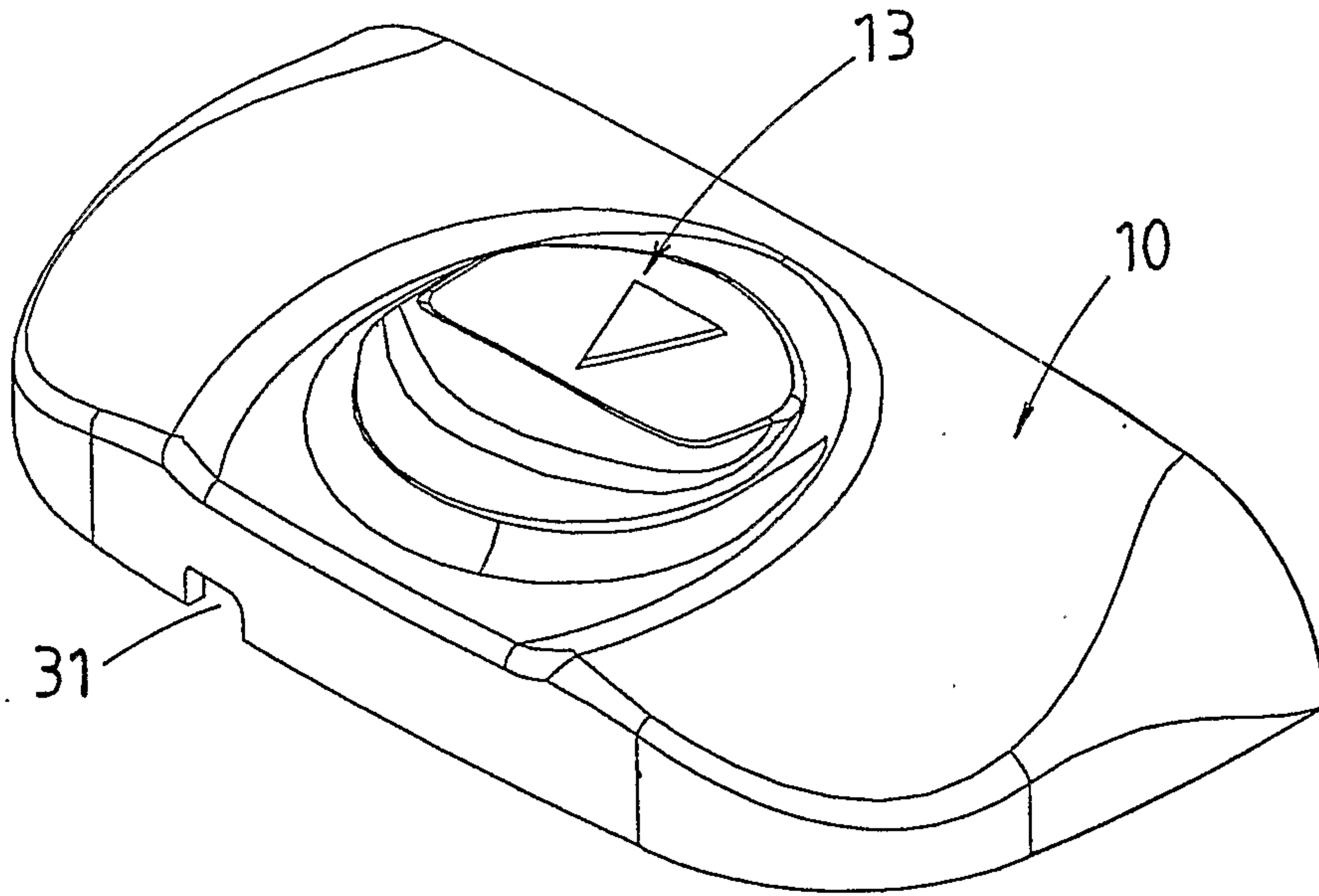

FIG. 1.

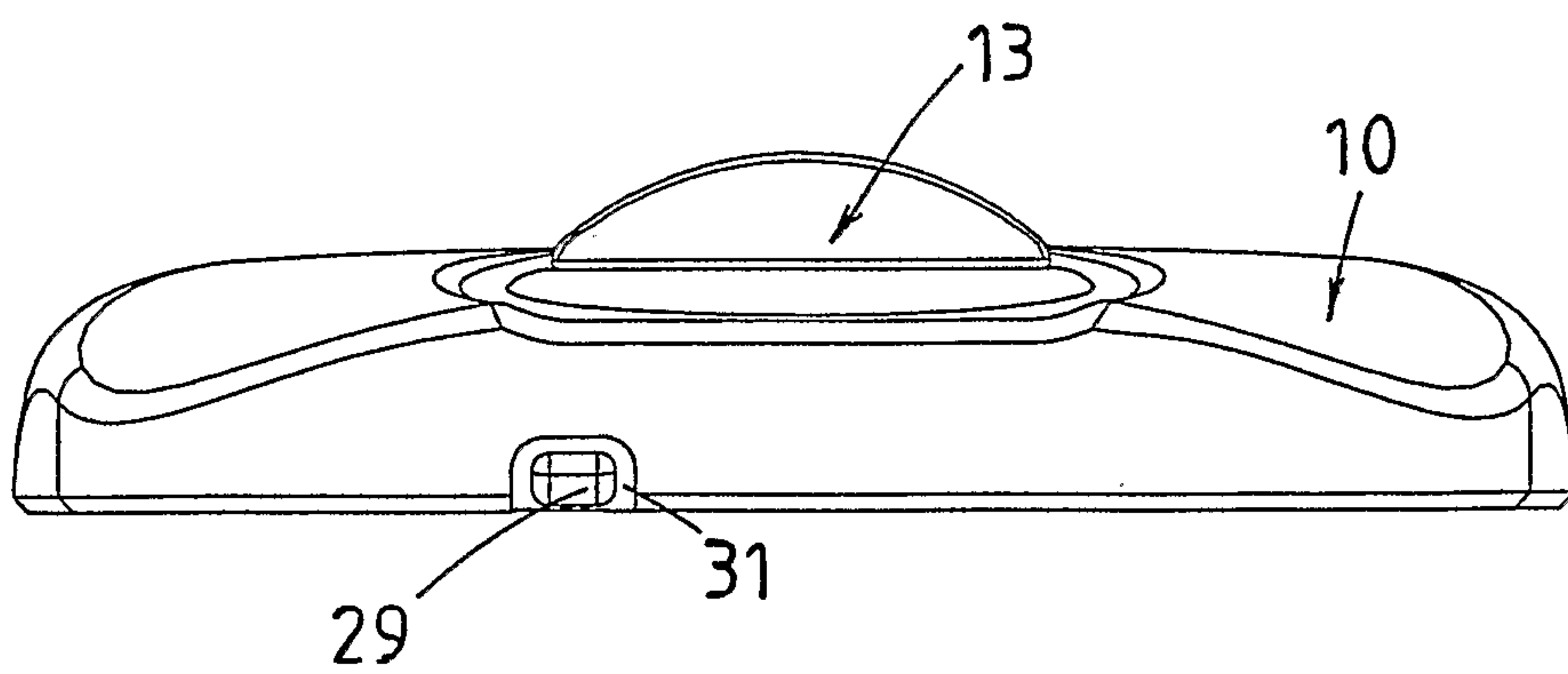

FIG. 2.



2/7

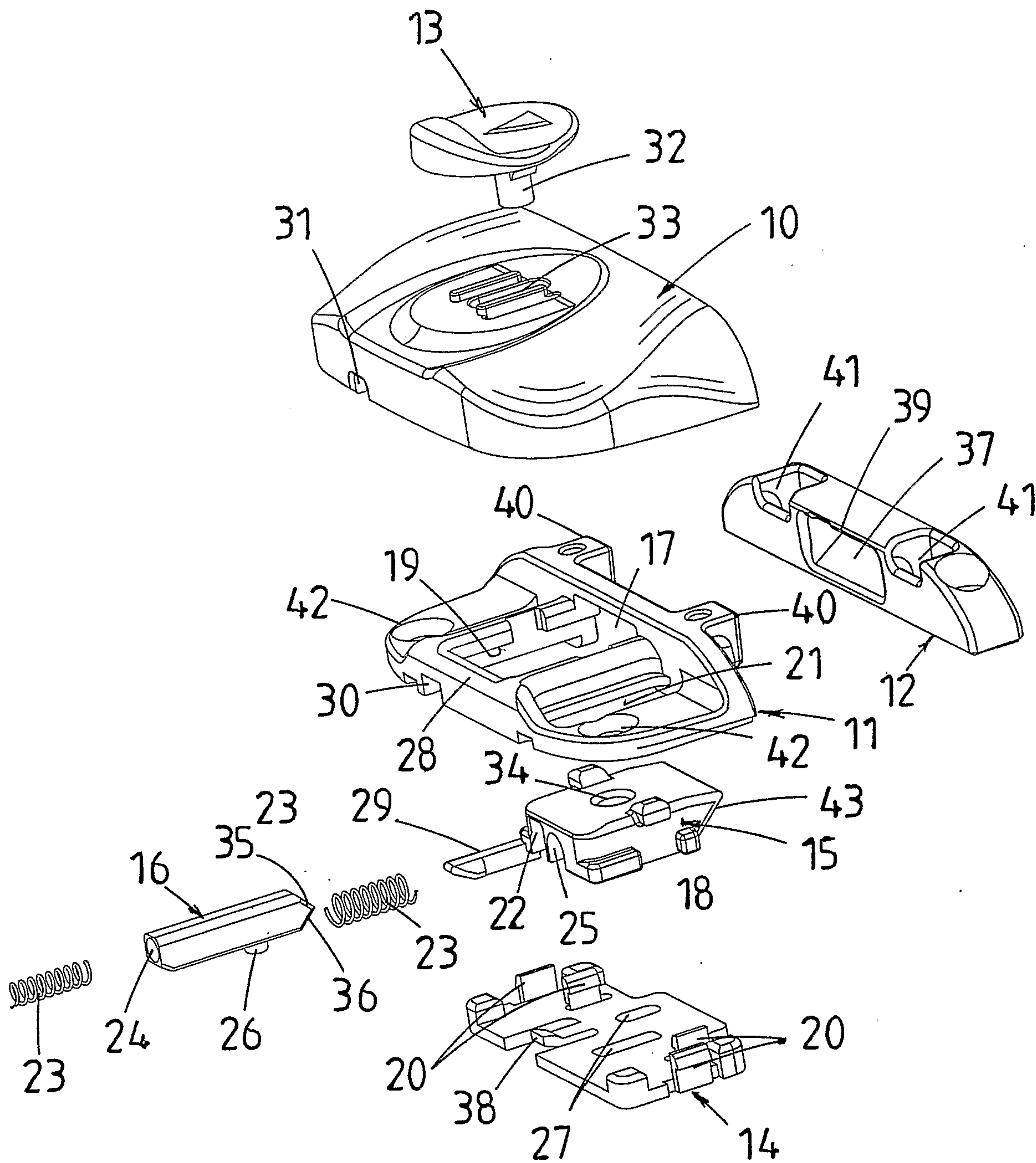

FIG. 3.

3/7

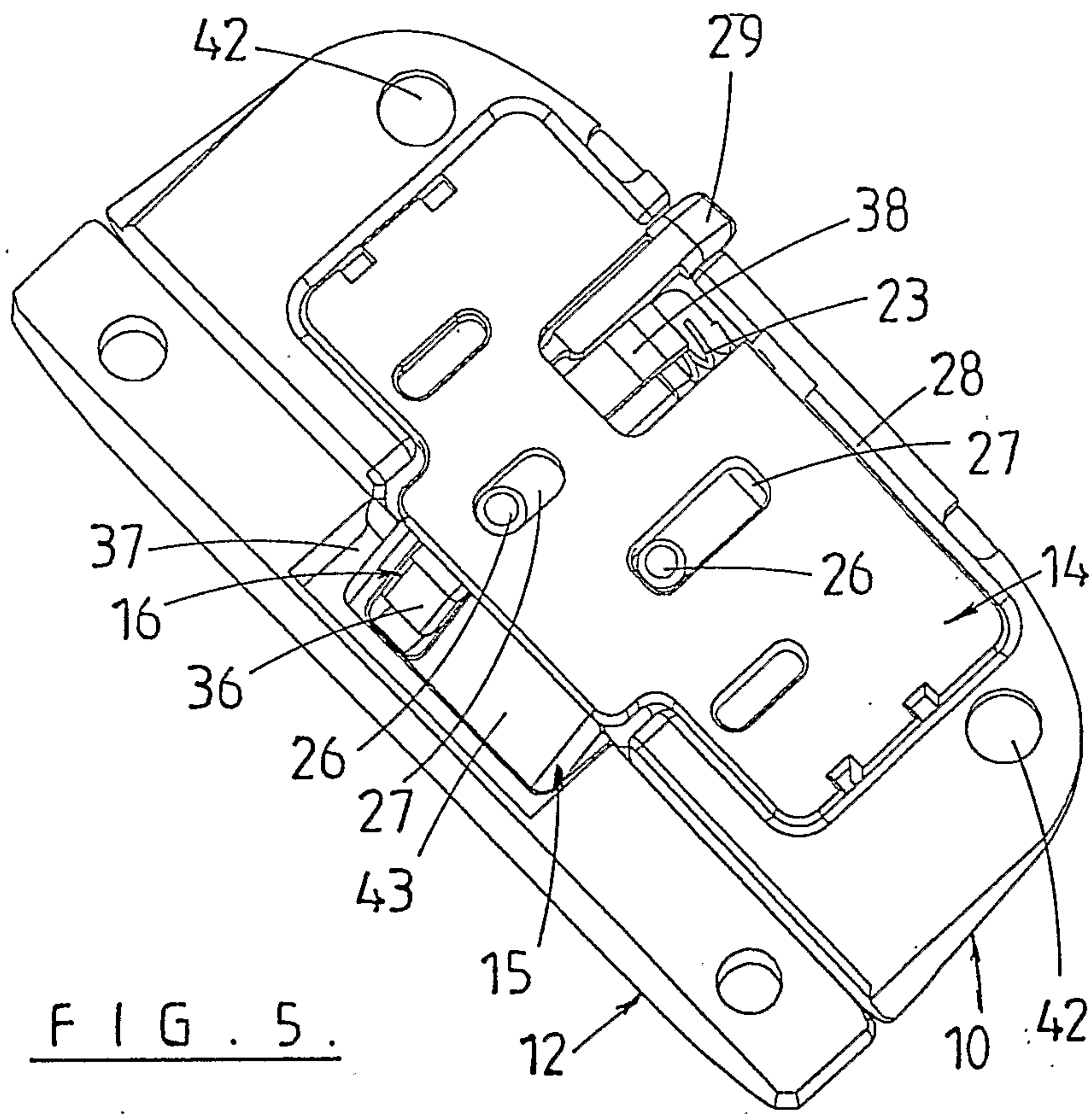

FIG. 5.

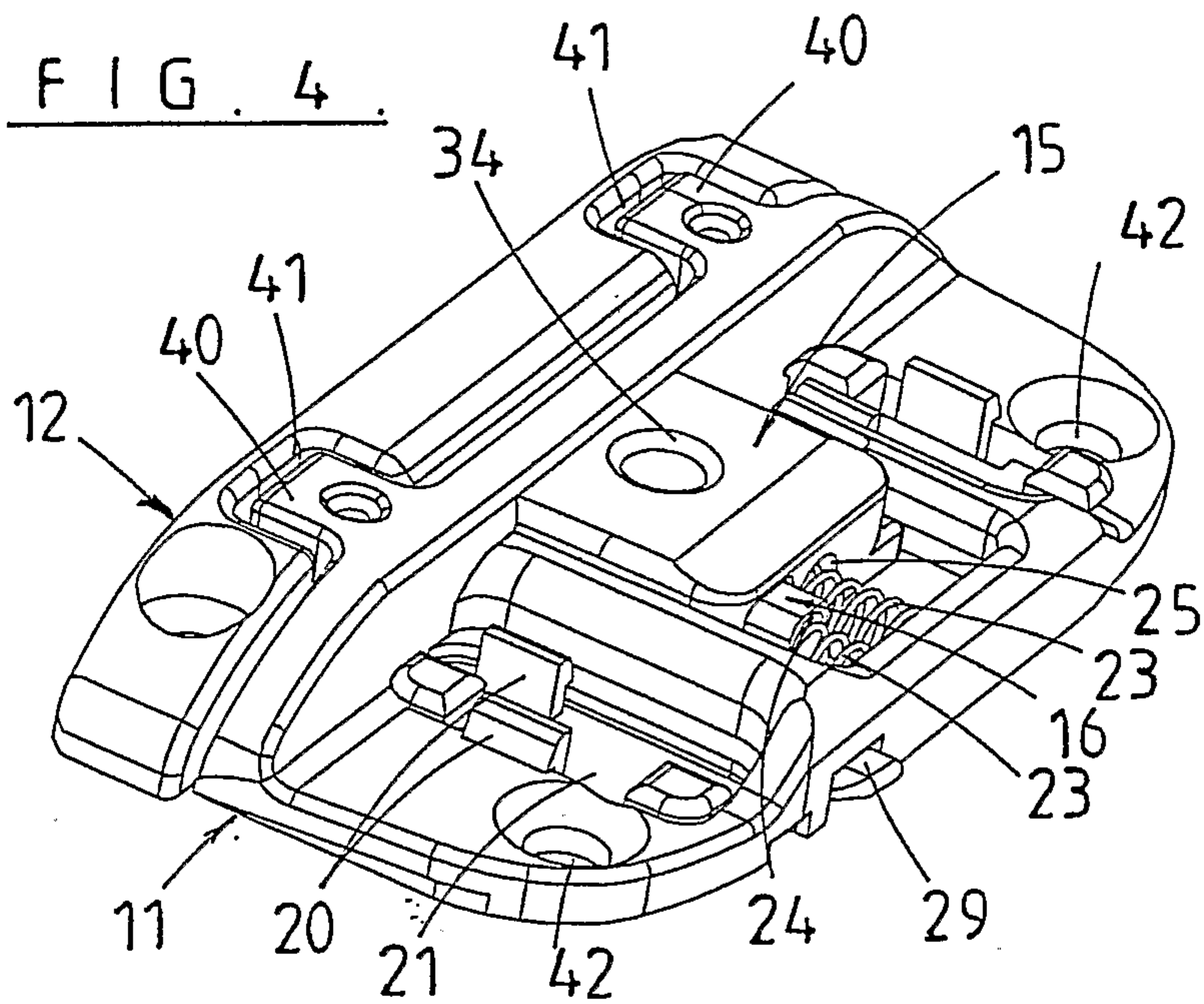

FIG. 4.

4/7

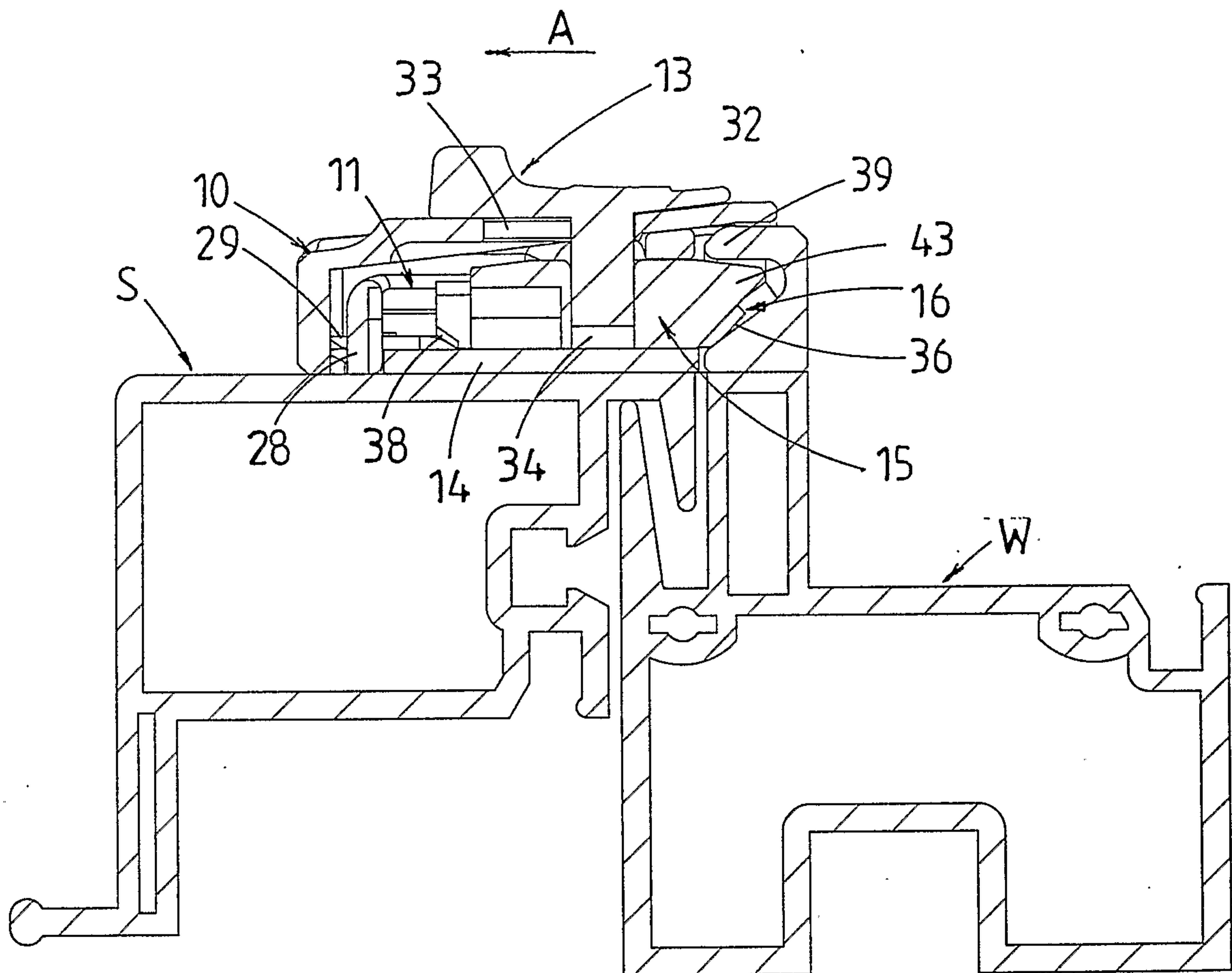

FIG. 6



5/7

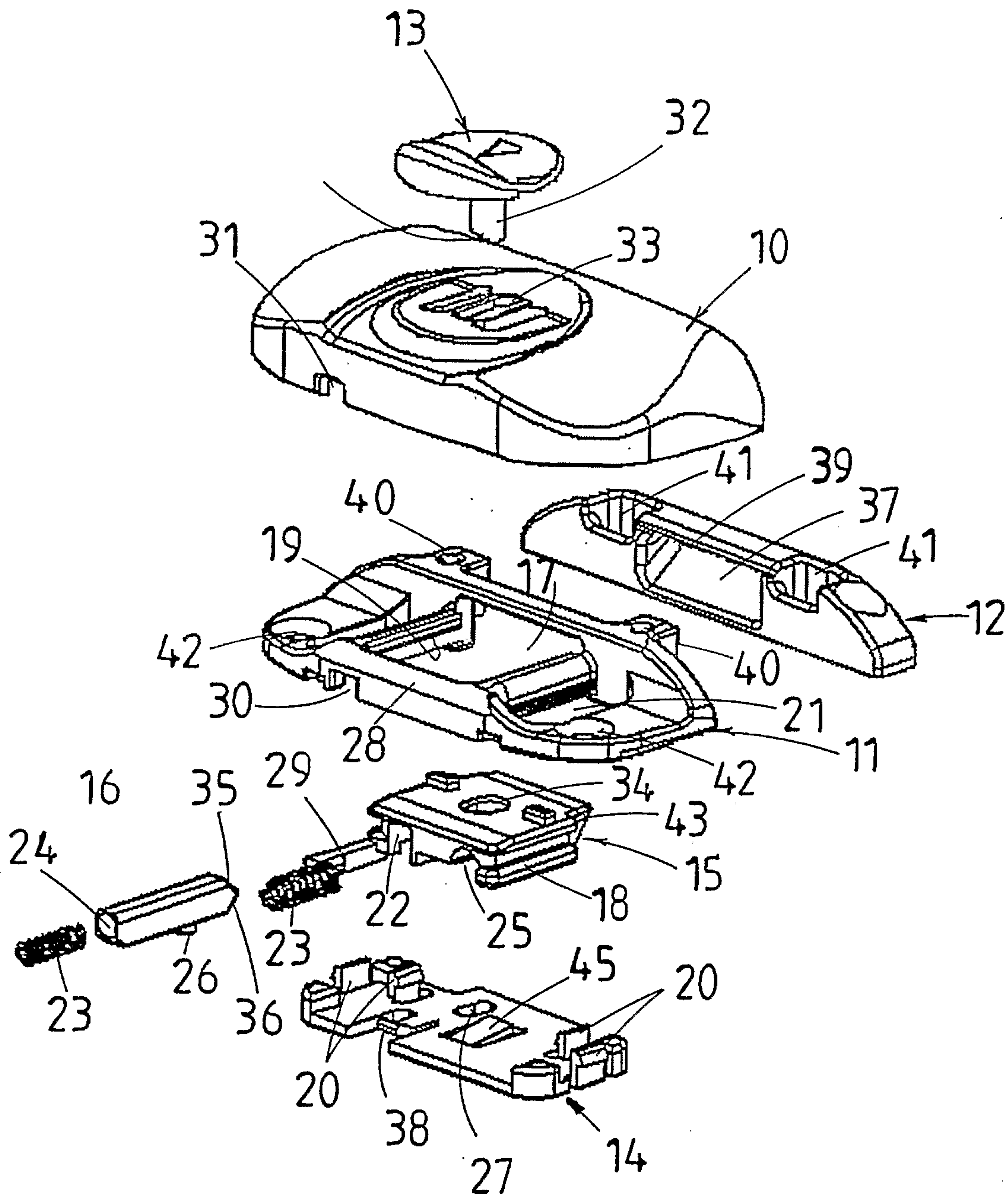

FIG. 7.

6/7

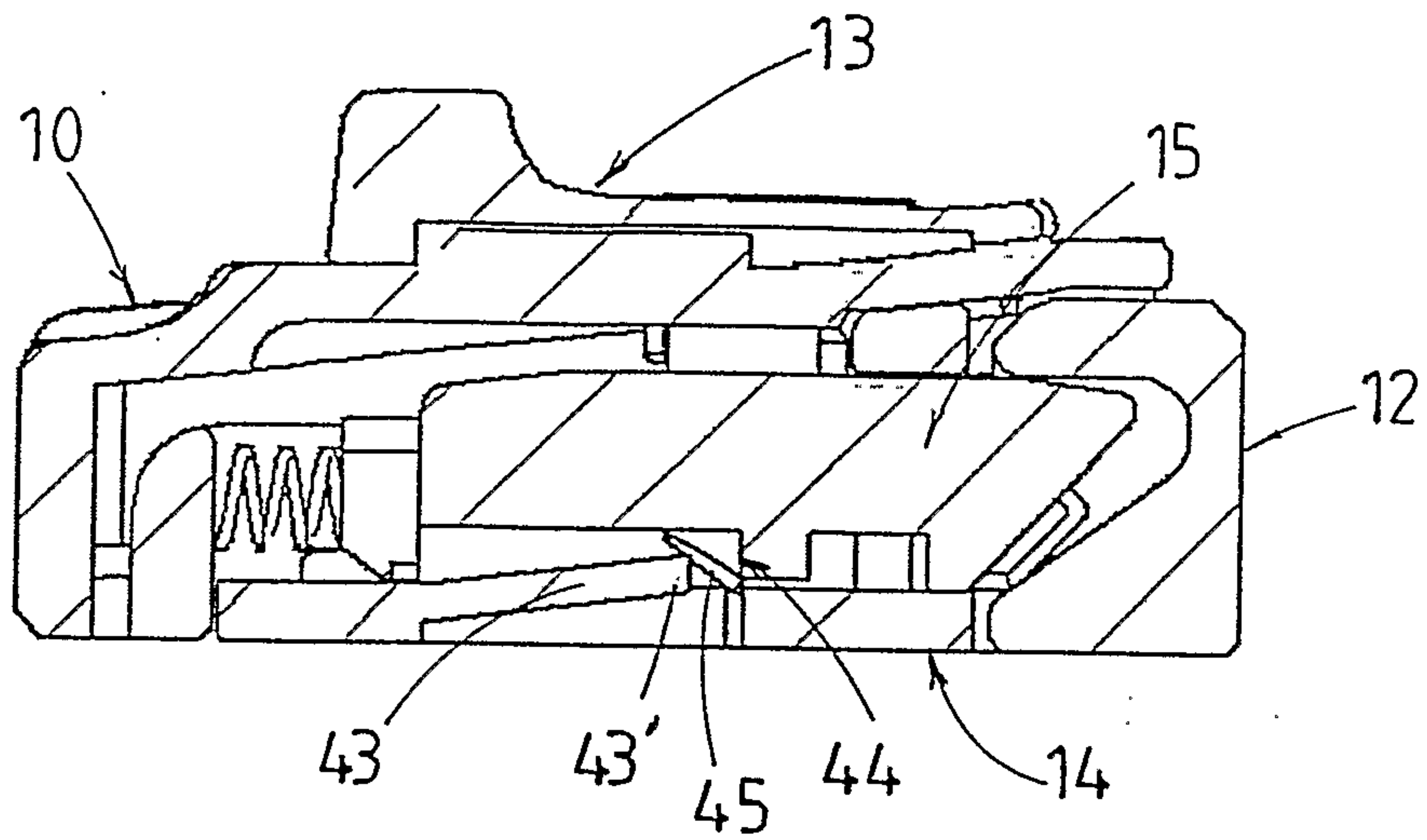

FIG. 8.

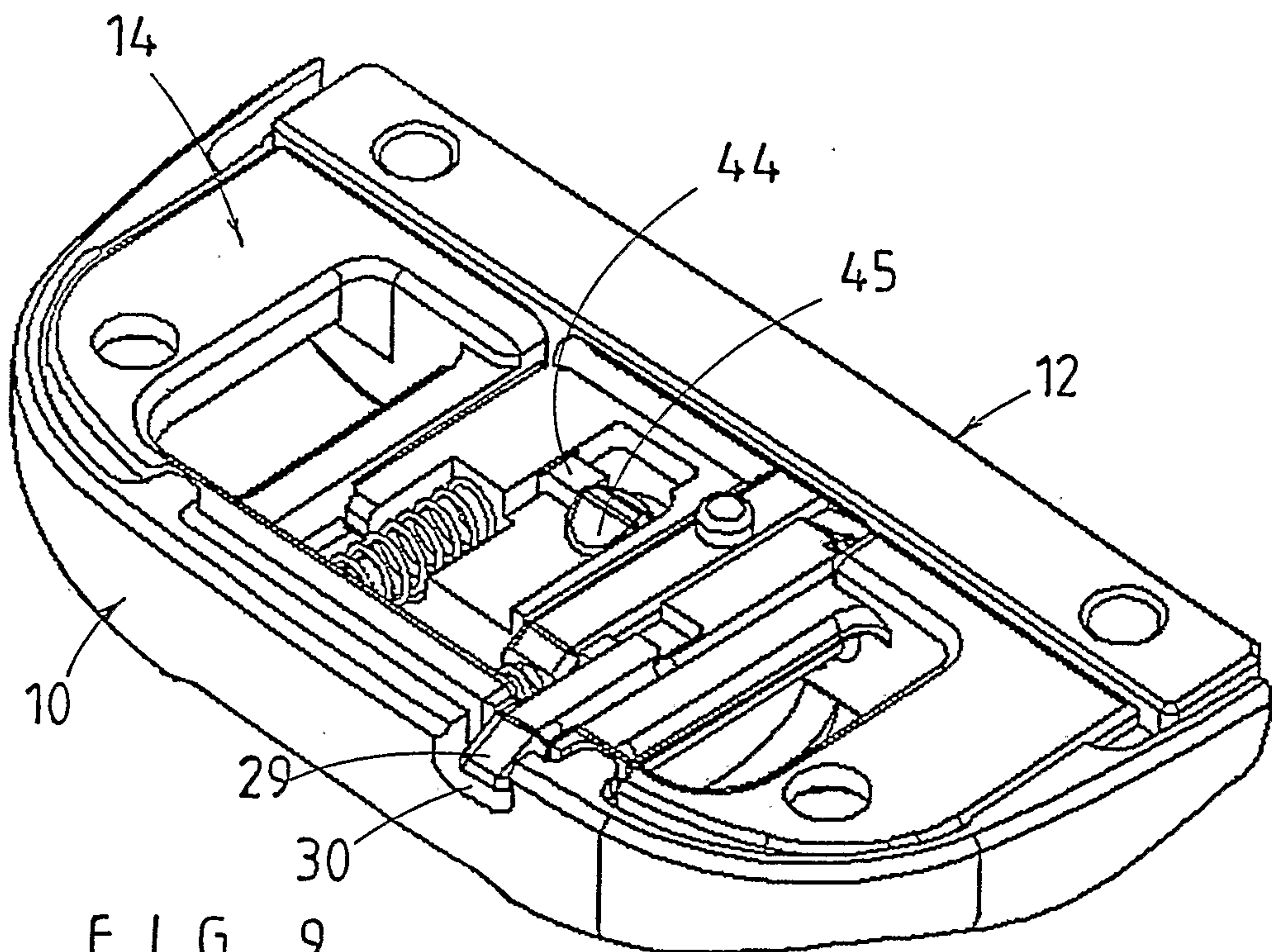

FIG. 9.

