

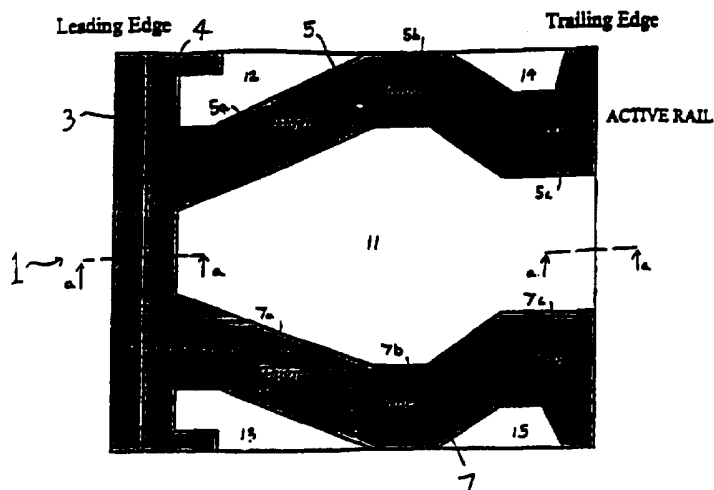

## INTERNATIONAL APPLICATION PUBLISHED UNDER THE PATENT COOPERATION TREATY (PCT)

|   |  |   |
|---|--|---|
| (51) International Patent Classification <sup>6</sup> :<br><b>G11B 5/60</b>   | <b>A1</b>  | (11) International Publication Number: <b>WO 96/19801</b><br>(43) International Publication Date: 27 June 1996 (27.06.96) |
| <p>(21) International Application Number: PCT/US95/16272</p> <p>(22) International Filing Date: 18 December 1995 (18.12.95)</p> <p>(30) Priority Data:<br/>08/358,432 20 December 1994 (20.12.94) US</p> <p>(71) Applicant: CONNER PERIPHERALS, INC. [US/US]; 3081 Zanker Road, San Jose, CA 95134-2128 (US).</p> <p>(72) Inventors: CHA, Ellis, Taeho; 1520 Vista Club Cir. #202, Santa Clara, CA 95054 (US). LEE, Jia-Kuen, Jerry; 1398 Sajak Avenue, San Jose, CA 95131 (US).</p> <p>(74) Agents: CHAMPLIN, Judson, K. et al.; Westman, Champlin &amp; Kelly, International Centre, Suite 1600, 900 Second Avenue South, Minneapolis, MN 55402 (US).</p> | <p>(81) Designated States: CA, CN, JP, KR, MX, SG, European patent (AT, BE, CH, DE, DK, ES, FR, GB, GR, IE, IT, LU, MC, NL, PT, SE).</p> <p><b>Published</b><br/><i>With international search report.<br/>Before the expiration of the time limit for amending the claims and to be republished in the event of the receipt of amendments.</i></p> |   |

(54) Title: MAGNETIC HEAD SUB-AMBIENT AIR PRESSURE SLIDER FOR A DISK DRIVE DEVICE OR THE LIKE



## (57) Abstract

A sub-ambient pressure, air bearing slider is disclosed for positioning a magnetic read/write head proximately to a rotating disk. The slider includes first and second rails extending along the side of the slider facing the rotating disk from a leading edge of the slider to a trailing edge of the slider. Each rail has a thigh region extending at an angle from the leading edge to a lateral side of the slider, a foot region extending at an angle from a lateral side of the slider toward the trailing edge of the slider, and a knee region at a lateral side of the slider coupled between the foot and thigh regions. Recesses are provided to shape the first and second rails. A central recess provides a volume for sub-ambient pressure. One or more tails can be placed within the central region to prevent the shifting of pressure completely to one side of the slider. The design of the first and second rails leads to a more uniform flying height for the slider and magnetic head over all tracks of the disk.

**FOR THE PURPOSES OF INFORMATION ONLY**

Codes used to identify States party to the PCT on the front pages of pamphlets publishing international applications under the PCT.

|           |                          |           |                                       |           |                          |
|-----------|--------------------------|-----------|---------------------------------------|-----------|--------------------------|
| <b>AT</b> | Austria                  | <b>GB</b> | United Kingdom                        | <b>MR</b> | Mauritania               |
| <b>AU</b> | Australia                | <b>GE</b> | Georgia                               | <b>MW</b> | Malawi                   |
| <b>BB</b> | Barbados                 | <b>GN</b> | Guinea                                | <b>NE</b> | Niger                    |
| <b>BE</b> | Belgium                  | <b>GR</b> | Greece                                | <b>NL</b> | Netherlands              |
| <b>BF</b> | Burkina Faso             | <b>HU</b> | Hungary                               | <b>NO</b> | Norway                   |
| <b>BG</b> | Bulgaria                 | <b>IE</b> | Ireland                               | <b>NZ</b> | New Zealand              |
| <b>BJ</b> | Benin                    | <b>IT</b> | Italy                                 | <b>PL</b> | Poland                   |
| <b>BR</b> | Brazil                   | <b>JP</b> | Japan                                 | <b>PT</b> | Portugal                 |
| <b>BY</b> | Belarus                  | <b>KE</b> | Kenya                                 | <b>RO</b> | Romania                  |
| <b>CA</b> | Canada                   | <b>KG</b> | Kyrgystan                             | <b>RU</b> | Russian Federation       |
| <b>CF</b> | Central African Republic | <b>KP</b> | Democratic People's Republic of Korea | <b>SD</b> | Sudan                    |
| <b>CG</b> | Congo                    | <b>KR</b> | Republic of Korea                     | <b>SE</b> | Sweden                   |
| <b>CH</b> | Switzerland              | <b>KZ</b> | Kazakhstan                            | <b>SI</b> | Slovenia                 |
| <b>CI</b> | Côte d'Ivoire            | <b>LI</b> | Liechtenstein                         | <b>SK</b> | Slovakia                 |
| <b>CM</b> | Cameroon                 | <b>LK</b> | Sri Lanka                             | <b>SN</b> | Senegal                  |
| <b>CN</b> | China                    | <b>LU</b> | Luxembourg                            | <b>TD</b> | Chad                     |
| <b>CS</b> | Czechoslovakia           | <b>LV</b> | Larvia                                | <b>TG</b> | Togo                     |
| <b>CZ</b> | Czech Republic           | <b>MC</b> | Monaco                                | <b>TJ</b> | Tajikistan               |
| <b>DE</b> | Germany                  | <b>MD</b> | Republic of Moldova                   | <b>TT</b> | Trinidad and Tobago      |
| <b>DK</b> | Denmark                  | <b>MG</b> | Madagascar                            | <b>UA</b> | Ukraine                  |
| <b>ES</b> | Spain                    | <b>ML</b> | Mali                                  | <b>US</b> | United States of America |
| <b>FI</b> | Finland                  | <b>MN</b> | Mongolia                              | <b>UZ</b> | Uzbekistan               |
| <b>FR</b> | France                   |           |                                       | <b>VN</b> | Viet Nam                 |
| <b>GA</b> | Gabon                    |           |                                       |           |                          |

**MAGNETIC HEAD SUB-AMBIENT AIR PRESSURE SLIDER  
FOR A DISK DRIVE DEVICE OR THE LIKE**

Field of the Invention

The present invention pertains to components of a magnetic storage device or disk drive device, and more particularly pertains to a magnetic air bearing slider providing consistent flying height over the various tracks of a disk.

Background of the Invention

Disk drives are commonly used in workstations, personal computers, laptops and other computer systems to store large amounts of data that are readily available to a user. In general, a disk drive comprises a magnetic disk that is rotated by a spindle motor. The surface of the disk is divided into a series of data tracks that extend circumferentially around the disk. Each data track can store data in the form of magnetic transitions on the disk surface.

An interactive element, such as a magnetic transducer, is used to sense the magnetic transitions to read data, or to generate an electric current that causes a magnetic transition on the disk surface, to write data. The magnetic transducer is mounted within a head and includes a read/write gap that contains the active elements of the transducer at a position suitable for interaction with the magnetic surface of the disk.

The head is mounted by a rotary actuator and is selectively positioned by the actuator over a preselected data track of the disk to enable the transducer to either

read data from or write data to the preselected data track of the disk, as the disk rotates below the transducer.

5 In modern disk drives, a relatively rigid or hard disk is used as the magnetic medium. The head includes a slider forming an air bearing surface that causes the transducer to fly above the data tracks of the disk surface due to fluid currents caused by rotation of the disk. Thus, the  
10 transducer does not physically contact the disk surface during normal operation of the disk drive. The amount of distance that the transducer flies above the disk surface is referred to as the "fly height." One advantageous type of head structure that operates at a fly height over  
15 the disk surface is a Transverse Pressure Contour (TPC) head. Current disk drive designs using a TPC head seek to limit the fly height to approximately 2  $\mu$  inches above the disk surface. Any contact between the head and the disk surface may result in damage to the disk or head.  
20 Accordingly, it is important to maintain an adequate fly height whenever the actuator positions the transducer over data tracks while the disk is rotating.

It is generally an objective to achieve an overall fly  
25 height that brings the read/write gap of the transducer as close to the disk surface as possible and to maintain the fly height at an even level regardless of the radial position of the actuator. The closer the active read/write gap of the transducer is brought to the  
30 surface of the disk, the stronger the electric signal generated by the transducer due to a magnetic transition on the disk surface which represents data. It is generally advantageous to develop as strong a data signal as possible, to insure reliable electrical performance of  
35 the disk drive.

A problem generally encountered with sliders is that the fly height varies over the various tracks of the disk, as

a function of the radial position of the actuator. Thus, at certain data tracks, the fly height is greater than at other data tracks. Accordingly, the data signal is not as strong as possible at all data tracks. Several  
5 designs have been proposed to improve the stability of fly height of the slider.

For example, the TPC slider mentioned above has two rails in a "catamaran" configuration. Transverse  
10 pressurization contours are provided along each side edge of the bearing surfaces. For each bearing surface, a skew angle (i.e., the angle between the axis of the slider (determined by the radial position of the  
15 actuator) and the tangential velocity of the magnetic disk) for the slider causes a pressurization at the contour of the bearing surface impinging upon the air flow from the disk and expansion adjacent to the contour of the bearing surface away from this air flow.

20 In certain other known slider designs, recesses are provided in the face of the slider facing the rotating disk to provide for sub-ambient pressure (i.e., less than 1 atm of pressure) between portions of the slider and the disk causing the slider to be pulled toward the rotating  
25 disk during operation. The sub-ambient pressure effects counteract, to some extent, the operation of the slider tending to lift the head from the disk surface. The net result is a tighter, stiff control over the fly height, that ideally resists changes in fly height.

30 In another slider design, chevrons or grooves are provided in the air bearing surfaces which allow flow of air between a sub-ambient, central recess and the areas external to the slider. In doing so, an improvement in  
35 roll of the slider is achieved. In another catamaran slider design, each air bearing surface is made narrower towards the central part of the slider to maintain as

near a constant air bearing surface area for each skew angle over the surface of the disk.

5 There is a need for a slider design that provides improved control over fly height variations over the data tracks of the magnetic disk, regardless of the radial position of the actuator. There is also a need for a slider design that decreases the roll angle of a slider.

10 Summary of the Invention

These and other needs are satisfied by the sub-ambient pressure slider of the present invention. The slider includes first and second rails extending along the bottom side of the slider from a leading edge of the slider to a trailing edge of the slider. The bottom side of the slider being the side that faces a rotating disk. One skilled in the art will appreciate that the bottom side of the slider of the present invention will face up if mounted on an arm underneath a rotating disk and will face down if mounted on an arm over a rotating disk.

Each of the first and second rails includes a thigh region extending at an angle from the leading edge to a lateral side of the slider, a foot region extending at an angle from the lateral side of the slider toward the trailing edge of the slider, and a knee region at the lateral side of the slider coupling the foot region to the thigh region. First and second thigh recesses are located towards the lateral side of each of the respective thigh regions of the first and second rails. First and second foot recesses are located on the bottom side of the slider towards the lateral side of each respective foot region of the first and second rails. A central recess is located on the bottom side of the slider between the thigh, knee, and foot regions of the first and second rails.

The first and second rails can have an approximately equal, uniform height, while the first and second thigh recesses, first and second foot recesses, and the central recess can have an approximately equal, uniform depth.

5

In an alternative embodiment of the present invention, at least one tail is provided extending from the leading edge of the slider toward the trailing edge of the slider and divides the central recess into at least two sections. In doing so, pressure shifts to one lateral side of the slider is avoided.

10

As in conventional sliders, a taper can be provided at a leading edge of the slider for channeling air flow to the bottom side of the slider. Also, a front section can be provided which extends from one lateral side of the slider to the opposing, lateral side of the slider. The front section and one or more tails can have a uniform height equal to that of the first and second rails.

15

20

In another embodiment of the present invention a central recess for the slider is fabricated having an approximately uniform depth. The uniform depth of the central recess is chosen such that a flying height of the slider over the tracks of the rotating disk is most insensitive to fluctuations in the chosen uniform depth. This uniform depth can be chosen so that the flying height as a function of recess depth is approximately at a minimum for all tracks of the rotating disk.

25

30

The slider design of the present invention provides for a more uniform flying height across the tracks of the disk. The addition of the one or more tails allows for a better control of the roll of the slider.

35

#### Brief Description of the Drawings

Fig. 1 is a top view of an embodiment of the slider of the present invention.

Figs. 1a and 1b are top views of an additional embodiment of the slider of Fig. 1 having a tail to control flying height and roll angle.

5 Fig. 1c shows a top view of a conventional catamaran slider having one and two tails, respectively, to control flying height and roll angle according to an embodiment of the present invention.

10 Fig. 2 is a side view along line a-a of Fig. 1.

Fig. 3 is a overhead view of an assembly for positioning a slider over the innermost track of a disk.

15 Fig. 4 is a overhead view of an assembly for positioning a slider over the middle track of a disk.

Fig. 5 is a overhead view of an assembly for positioning a slider over the outermost track of a disk.

20

Fig. 6 is a graph of flying height versus recess depth of a slider.

#### Detailed Description

25 Referring to Figs. 1 and 2, an exemplary embodiment of the sub-ambient pressure slider of the present invention is shown. The slider 1 includes a taper 3 at the leading edge of the slider 1 which channels air flow underneath the slider 1. In this embodiment, the width of the  
30 slider 1 and the taper 3 is 60 mils (i.e., 0.06 inches) while the length and depth of the taper 3 is 8 mils. The taper 3 can lead into a front section 4. Along the length of the slider two rails 5, 7 are provided that vary significantly from the catamaran design known in the  
35 art. Each rail 5, 7 includes three major sections: a thigh section 5a, 7a; a knee section 5b, 7b; and a foot section 5c, 7c. In this embodiment, the front section 4 and all sections 5a-c, 7a-c of the rails 5, 7 of the



slider 1 are at the same height (e.g., in this embodiment, the height of the slider is 17 mils).

Several recess sections 11-15 are provided in the slider.

5 In this embodiment, all recesses 11-15 have the same depth (e.g., the depth of the recess regions is approximately 150  $\mu$  inches as measured from the top of the first and second rails 5, 7). The central recess 11  
10 has a somewhat diamond shape due to the thigh sections and foot sections of the rails. Thigh recesses 12, 13 are located outside of the thigh regions 5a, 7a. Foot recesses 14, 15 are located outside of the foot regions 5c, 7c.

15 As is conventional in the art, a magnetic head (not shown specifically in Figs. 1-2 is coupled at the rear of the slider 1, proximate to the foot region 5c (denoted "ACTIVE RAIL" in Fig. 1).

20 Operation of the slider of the present invention is shown with respect to Figs 3-5. As the disk 17 rotates, air is channeled by the taper 3 of the slider 1 to flow underneath the slider. It should be noted that the taper 3 also assists in a fast take-off of the slider 1 when  
25 the disk 17 is initially rotated. Air is pressurized underneath the rails 5, 7 of the slider which causes the slider 1 (and thus the magnetic head) to lift off of the surface of the disk 17. In the recess regions 11-15, air "expands" to the sub-ambient pressure which generates a  
30 suction force causing the slider (and thus the magnetic head) to be pulled toward the moving disk.

In Figs. 3-5, the slider 1 is shown mounted to an arm 19 and an actuator 21, which positions the slider 1 and  
35 magnetic head over a desired track. In Fig. 3, the slider 1 is positioned proximately to the innermost track of the disk 17. Referring again to Fig. 1, the thigh regions 5a, 7a of the first and second rails 5, 7 extend

from the front, middle part of the slider 1 outward to two opposing sides of the slider where the knee sections 5b, 7b meet the sides of the slider. The angle that the thigh regions 5a, 7a make with the forward region 4 is  
5 designed to be approximately the same as the slider skew angle when the slider is present at the innermost track. The innermost track is also known as the contact start-stop (CSS) zone. At the innermost track (hereinafter referred to as the inner diameter or "ID"), the disk  
10 surface velocity is at its lowest. The orientation of the thigh regions 5a, 7a assists in preventing pressure underneath the first and second rails 5, 7 from leaking to the sides of the slider 1 (thus causing the slider to fly at a lower than desired height).

15

Referring to Fig. 4, the slider 1 is positioned approximately at the middle track (i.e., the track at a mean distance between the inner and outer tracks). At the middle track the skew angle is approximately zero.  
20 Because of the design of the thigh regions 5a, 7a of the slider 1, pressure leakage to the sides of these regions is greater. The loss of pressure due to leakage at the thigh regions 5a, 7a is compensated by the increase in surface velocity of the disk 17. The flying height of  
25 the slider 1 would be at its greatest at the middle track except for the action of the foot recesses 14, 15, which act to reduce the area of pressurization for the slider 1 and, thus, reducing the lift force generated at the foot sections 5c, 7c of the first and second rails 5, 7.

30

Referring to Fig. 5, the slider 1 and magnetic head are placed over the outermost track (hereinafter referred to the outer diameter or "OD"). The large skew angle at the OD causes a greater amount of pressure to leak to the  
35 sides of the rails 5, 7. Because of the design of the thigh regions 5a, 7a of the slider 1, very little pressure is generated at these regions because of the relatively small pad length. Most of the pressure under

the slider is generated under the knee regions 5b, 7b of the slider 1. Although, the pad area below the knee is small, the large disk surface velocity at the OD gives generates enough pressure to under the rails 5, 7 of the slider 1 to maintain a constant flying height.

As mentioned above, the recess regions 11-15 generate sub-ambient pressure that pulls the slider towards the disk surface. The majority of the sub-ambient pressure is formed at the central recess 11. The thigh recesses 12, 13 provide extra roll stiffness for the slider 1. The foot recesses 14, 15 reduce the effective pressurization area at the foot of the slider 1 so that it will not fly too high above the disk surface at a near zero skew angle. Also, the foot recesses 14, 15 reshape the foot regions 5c, 7c, of the rails 5, 7 so that these regions are parallel to the incoming air when the slider 1 is at an outer track. To this point, the flying height of the outer rail (i.e., rail 5) has been controlled by the design of the slider. To control slider roll (i.e., the difference in flying height of the innermost rail 7 and the outermost rail 5), the shape of the inner rail (i.e., rail 7) can be adjusted in a like manner to control the flying height of the inner rail.

A further embodiment of the present invention is shown in Figs. 1a and 1b. The central recess 11 of the slider 1 is the largest receptacle for sub-ambient pressure in the slider. The central recess 11 has a large effect on how constant the flying height of the slider 1 is over the surface of the disk 17 as well as the amount of roll for the slider 1. As an additional measure for controlling flying height and roll for the slider 1, one or more tails 2 are "added" to the central recess 11. In the manufacture of the slider, the tail region(s) are formed by etching or removing the material around them as the central recess 11 is formed.

When the slider 1 has a large skew angle, the angle at which air flows under the slider 1 is also large. This results in pressure leakage to the sides of the rails 5, 7 causing the decrease in the pressure under the rails, and shift in the center of pressure. The decrease in the pressure results in lower flying height, and the shift in the center of pressure results in an increased roll angle. Also, the central recess 11 acts to couple the flying height of one rail to the deviation in dimensions of the other rail. Because of their relatively narrow configuration, the tail(s) 2 do not form an appreciably significant air bearing surface. Rather, the tail(s) 2 divide the central recess 11 into two or more volumes, thus preventing distribution of sub-ambient pressure within the central recess 11 from entirely shifting to one side of the slider 1. By optimizing the length and orientation of the tail(s) 2, the effect of suction force on the roll angle of the slider 1 can be controlled. The dashed lines in Figs. 1a and 1b show possible orientations and lengths for the tails(s) 2. Also, the use of tail(s) 2 prevents the coupling of the flying height of one rail to the change in the dimension of the other.

Referring to Fig. 1c, a conventional catamaran slider is shown having tails 4 as described above.

The depth of the central recess 11 can have a substantial effect on flying height over all tracks of a disk. In high altitude environments, the change in pressure and the mean-free path of air can also have an effect on flying height. By choosing an appropriate depth for the central recess 11, the range of flying height values (i.e., the difference between the maximum and minimum flying height of the head over all tracks of a disk) can be substantially smaller than with typical catamaran-type sliders. Referring to Fig. 6, a graph is shown having flying height along the Y-axis and recess depth along the

X-axis for the ID, middle diameter ("MD"), and OD (i.e., flying height is shown as a function of recess depth). With a typical recess depth of 200 microinches, the flying height for the slider will fall along steep slopes of the ID, MD, and OD curves. This will cause greater flying height sensitivity depending on the recess depth chosen and the altitude at which the slider is used. If a recess depth is chosen when the slopes of the ID, MD, and OD curves are at a minimum (i.e., the uniform depth is chosen such that the flying height as a function of recess depth is approximately at a minimum for all tracks of the rotating disk -- in the 110-150 microinches range), the sensitivity of the slider to recess depth variations due to tolerances and operating altitude is minimized. Another advantage of choosing the recess using the aforementioned technique is that the air-bearing stiffness is maximized which helps in reducing the flying height sensitivity further.

Claims:

1. A sub-ambient pressure, air bearing slider for positioning a magnetic read/write head proximately to a rotating disk, said slider comprising:

first and second rails extending along the bottom side of said slider from a leading edge of said slider to a trailing edge of said slider, said bottom side of said slider for facing a rotating disk, each of said first and second rails including:

a thigh region extending at an angle from said leading edge to a lateral side of said slider;

a foot region extending at an angle from said lateral side of said slider toward the trailing edge of said slider; and

a knee region at said lateral side of said slider coupling said foot region to said thigh region;

first and second thigh recesses located towards the lateral side of said respective thigh regions of said first and second rails;

first and second foot recesses located on the bottom side of said slider towards the lateral side of said respective foot regions of said first and second rails; and

a central recess located on the bottom side of said slider between said thigh, knee, and foot regions of said first and second rails.

2. The slider of claim 1 wherein said first and second rails have an approximately equal, uniform height.

3. The slider of claim 1 wherein said first and second thigh recesses, first and second foot recesses, and said central recess have an approximately equal, uniform depth.

4. The slider of claim 2 wherein said first and second thigh recesses, first and second foot recesses,

and said central recess have an approximately equal, uniform depth.

5. The slider of claim 1 further comprising:  
at least one tail extending from the leading edge of said slider toward the trailing edge of said slider and dividing said central recess into at least two sections.

6. The slider of claim 5 wherein each tail and said first and second rails have an approximately equal, uniform height.

7. The slider of claim 5 wherein each tail extends at an angle from the leading edge of said slider.

8. The slider of claim 5 wherein each tail has a width substantially narrower than a width of each of said first and second rails.

9. The slider of claim 1 wherein the angle at which the thigh regions extend from the leading edge of said slider is approximately equal to a slider skew angle when the slider is present at an innermost track of the rotating disk.

10. A sub-ambient pressure, air bearing slider for positioning a magnetic read/write head proximately to a rotating disk, said slider comprising:

a taper formed at a leading edge of said slider, said taper channeling air flow to a bottom side of said slider, said bottom side of said slider for facing a rotating disk;

a front section extending from a first lateral side of said slider to a second, opposing side of said slider;

first and second rails extending along the bottom side of said slider from the front section of said

slider to a trailing edge of said slider, each of said first and second rails including:

a thigh region extending at an angle from said leading edge to one of said lateral sides of said slider;

a foot region extending at an angle from one of said lateral sides of said slider toward the trailing edge of said slider; and

a knee region at one of said lateral sides of said slider coupling said foot region to said thigh region;

first and second thigh recesses located towards the lateral side of said respective thigh regions of said first and second rails;

first and second foot recesses located on the bottom side of said slider towards one of the lateral sides of said respective foot regions of said first and second rails; and

a central recess located on the bottom side of said slider between said thigh, knee, and foot regions of said first and second rails.

11. The slider of claim 10 wherein said front section and said first and second rails have an approximately equal, uniform height.

12. The slider of claim 10 wherein said first and second thigh recesses, first and second foot recesses, and said central recess have an approximately equal, uniform depth.

13. The slider of claim 11 wherein said first and second thigh recesses, first and second foot recesses, and said central recess have an approximately equal, uniform depth.

14. The slider of claim 10 further comprising:



at least one tail extending from the leading edge of said slider toward the trailing edge of said slider and dividing said central recess into at least two sections.

15. The slider of claim 10 wherein each tail and said first and second rails have an approximately equal, uniform height.

16. The slider of claim 10 wherein each tail extends at an angle from the leading edge of said slider.

17. The slider of claim 10 wherein each tail has a width substantially narrower than a width of each of said first and second rails.

18. The slider of claim 10 wherein the angle at which the thigh regions extend from the leading edge of said slider is approximately equal to a slider skew angle when the slider is present at an innermost track of the rotating disk.

19. A sub-ambient pressure, air bearing slider for positioning a magnetic read/write head proximately to a rotating disk, said slider comprising:

a taper formed at a leading edge of said slider, said taper channeling air flow to a bottom side of said slider, said bottom side of said slider for facing a rotating disk;

a front section extending from a first lateral side of said slider to a second, opposing side of said slider;

first and second rails extending along the bottom side of said slider from the front section of said slider to a trailing edge of said slider;

a central recess located on the bottom side of said slider between said first and second rails;

at least one tail extending from the front section of said slider toward the trailing edge of said slider and dividing said central recess into at least two sections.

20. The slider of claim 19 wherein said front section, each of said tails and said first and second rails have an approximately equal, uniform height.

21. The slider of claim 19 wherein said central recess has an approximately equal, uniform depth.

22. The slider of claim 19 wherein each tail extends at an angle from the leading edge of said slider.

23. The slider of claim 19 wherein each tail has a width substantially narrower than a width of each of said first and second rails.

24. A method of manufacturing a sub-ambient pressure, air bearing slider for positioning a magnetic read/write head proximately to a rotating disk, said method comprising:

forming first and second rails along a bottom side of said slider from a leading edge of said slider to a trailing edge of said slider;

forming a central recess on the bottom side of said slider, said central recess located between said first and second rails, wherein said central recess has an approximately uniform depth, said uniform depth being chosen such that a flying height of said slider over said rotating disk is most insensitive to fluctuations in said uniform depth.

25. The method of claim 24, wherein said uniform depth is chosen such that the flying height as a function of recess depth is approximately at a minimum for all tracks of the rotating disk.

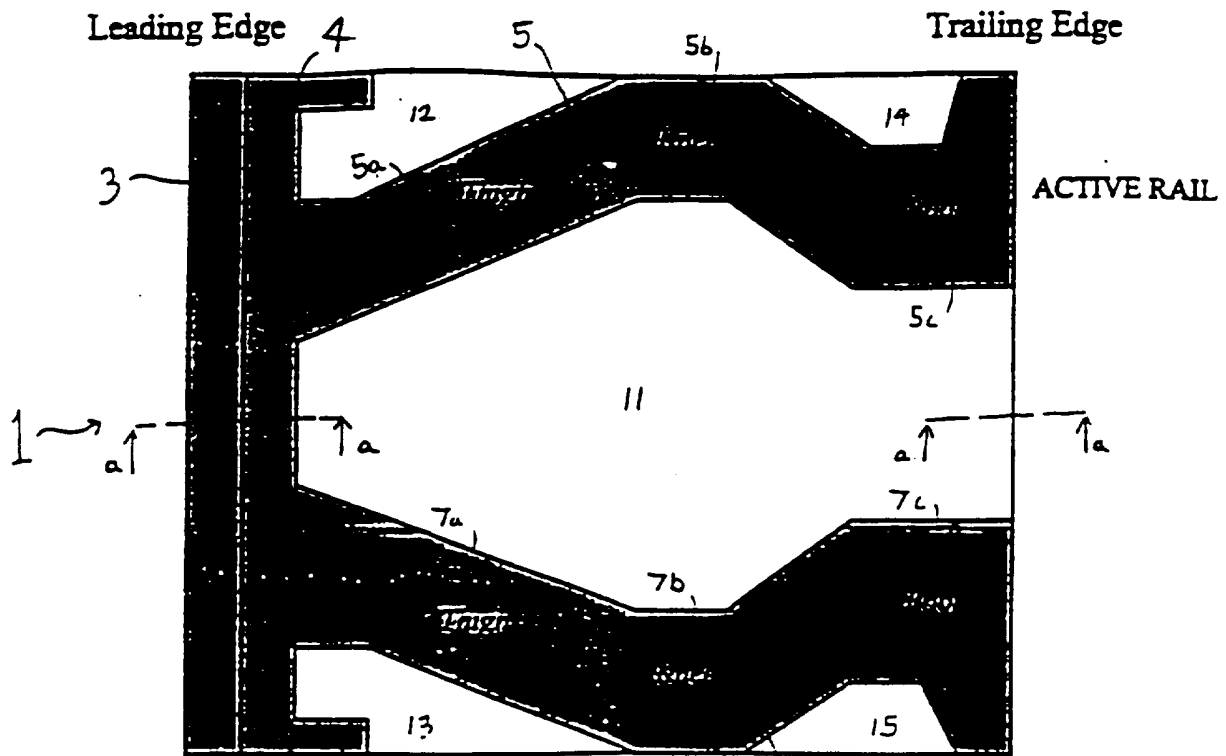

Figure 1

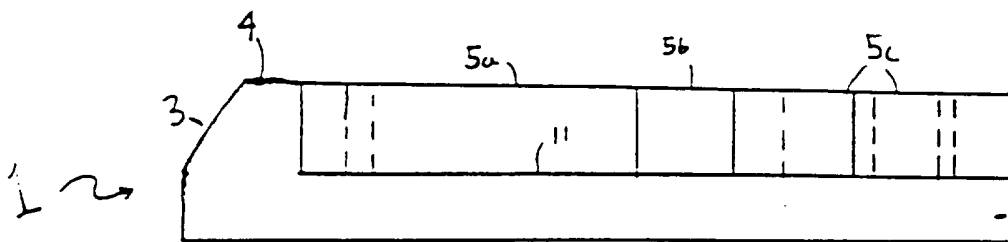

Figure 2

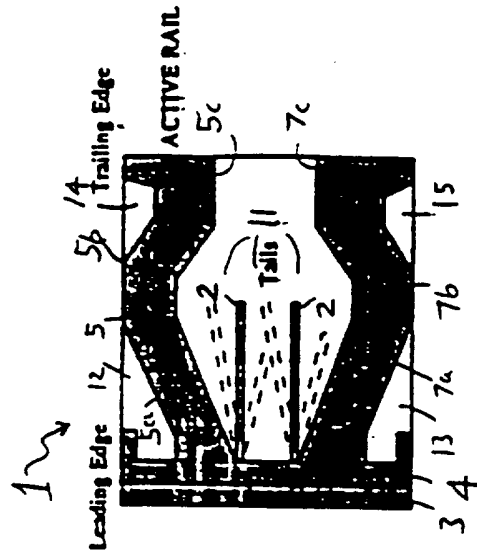

Figure 1b

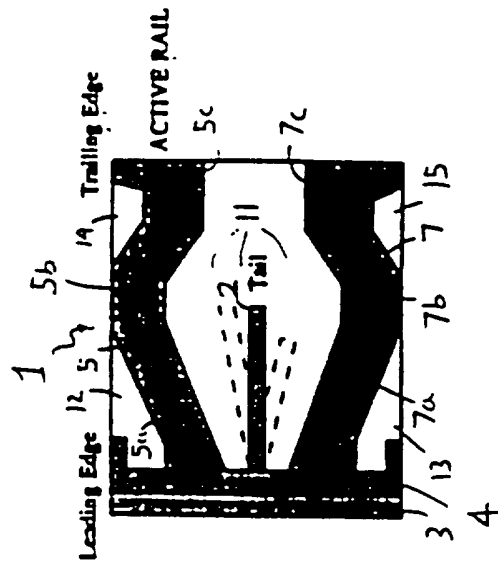

Figure 1a

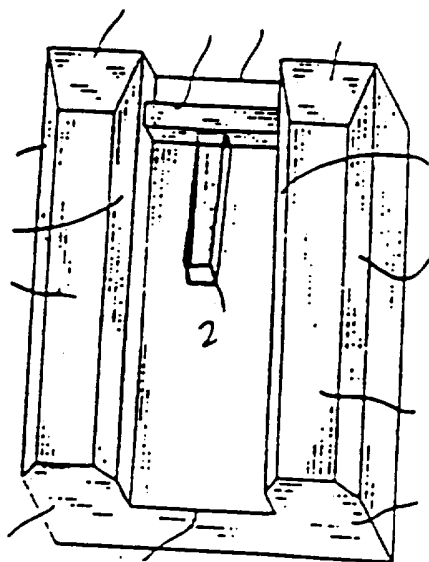
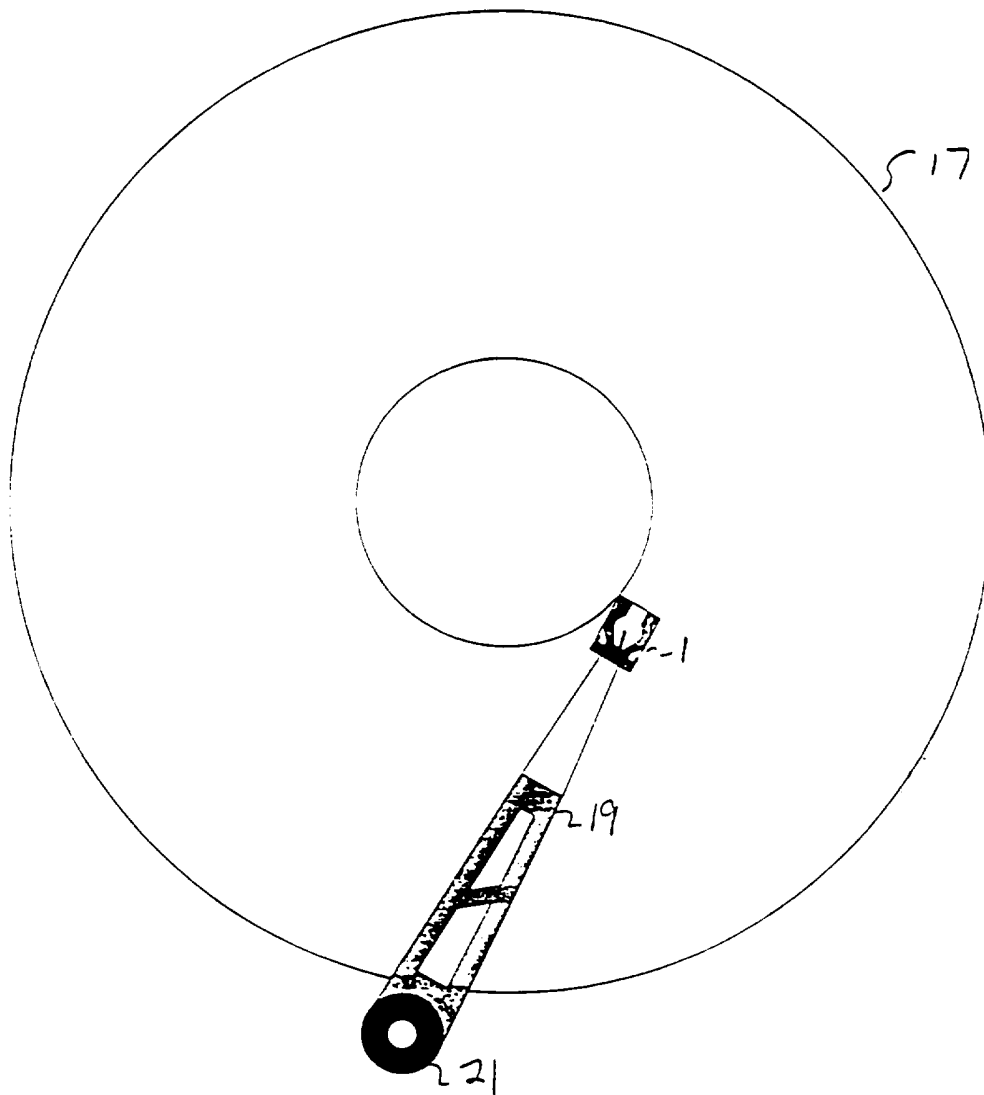
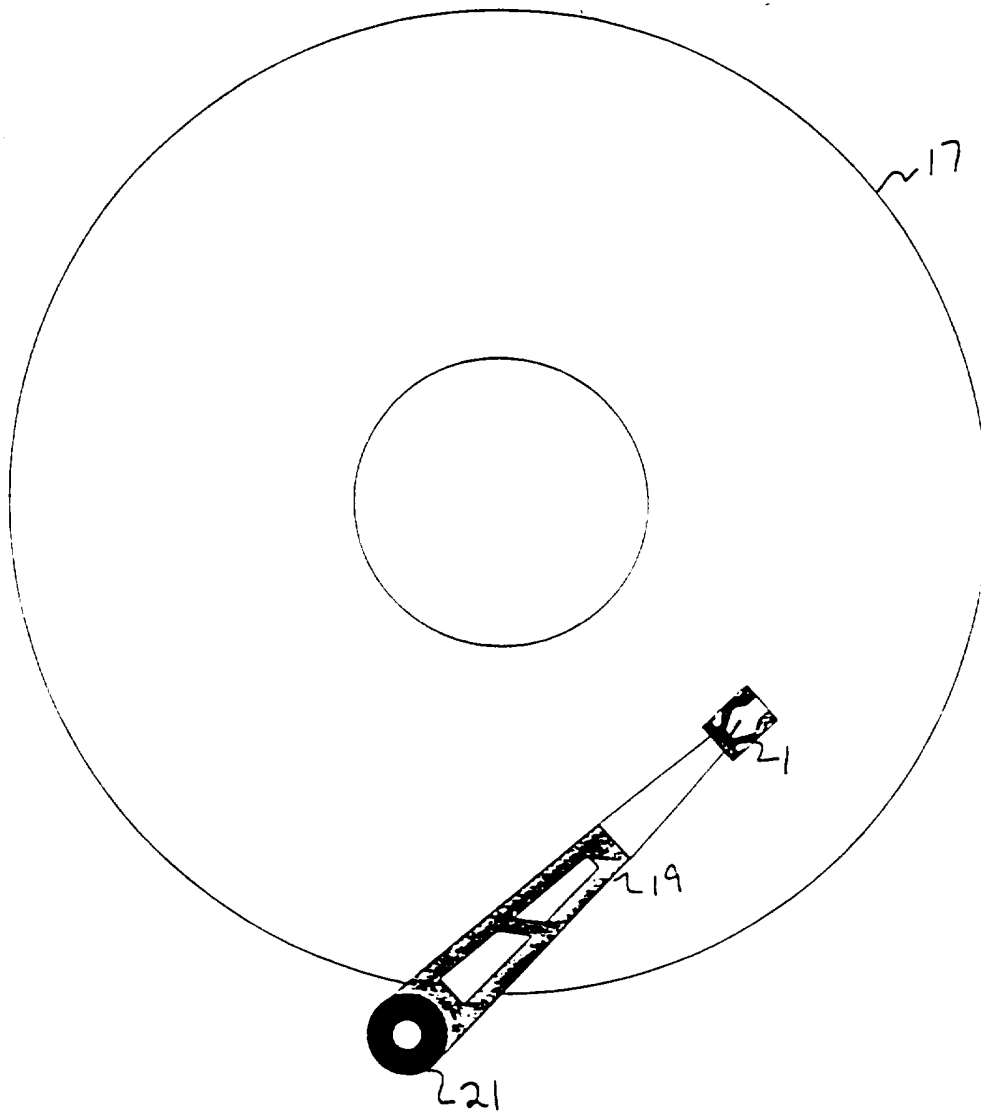

Figure 1c



**Slider at Inner Radius**

Fig. 3



**Slider at Middle Radius**

Fig. 4/

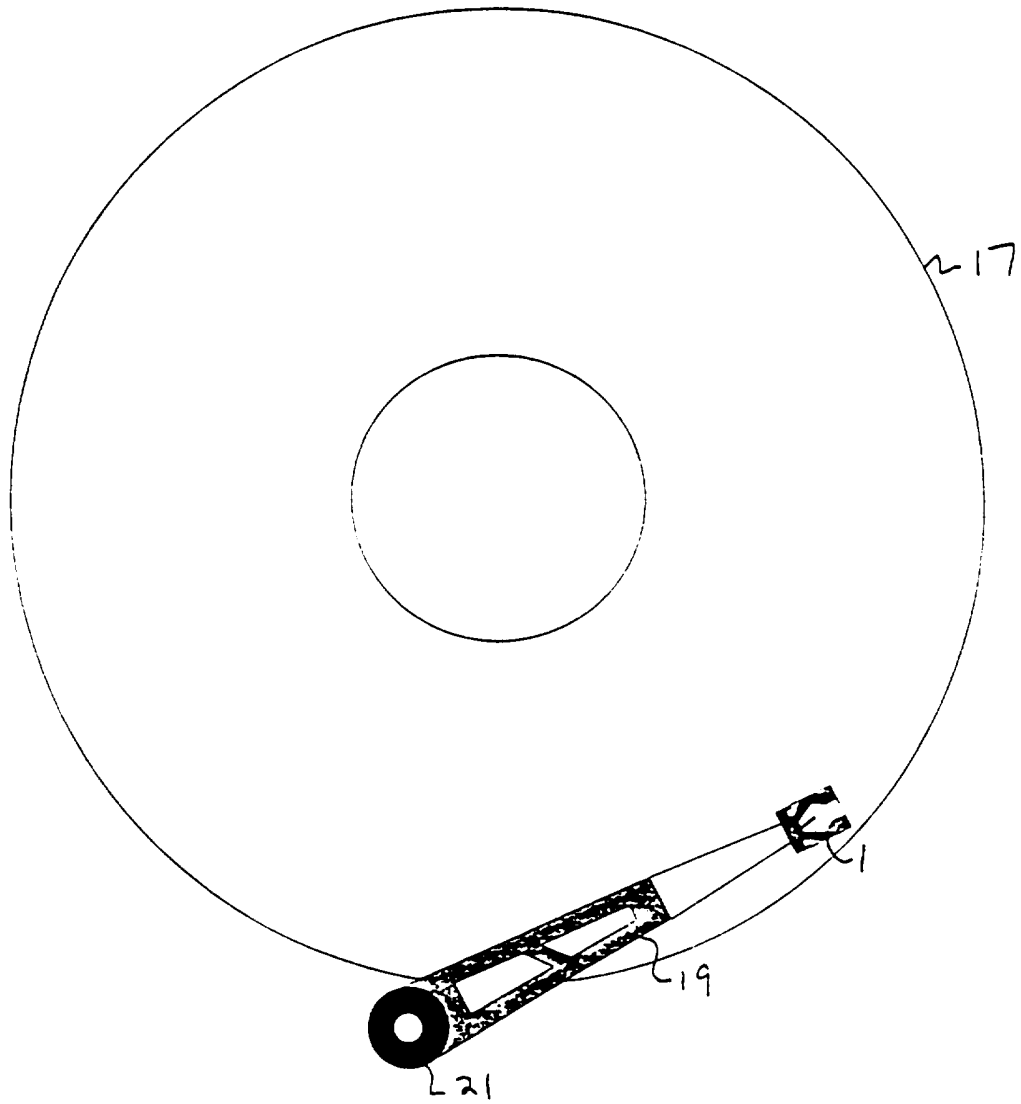

**Slider at Outer Radius**

Fig 5



### R/W Gap Flying Height vs. Recess Depth Sub-Ambient Pressure Slider

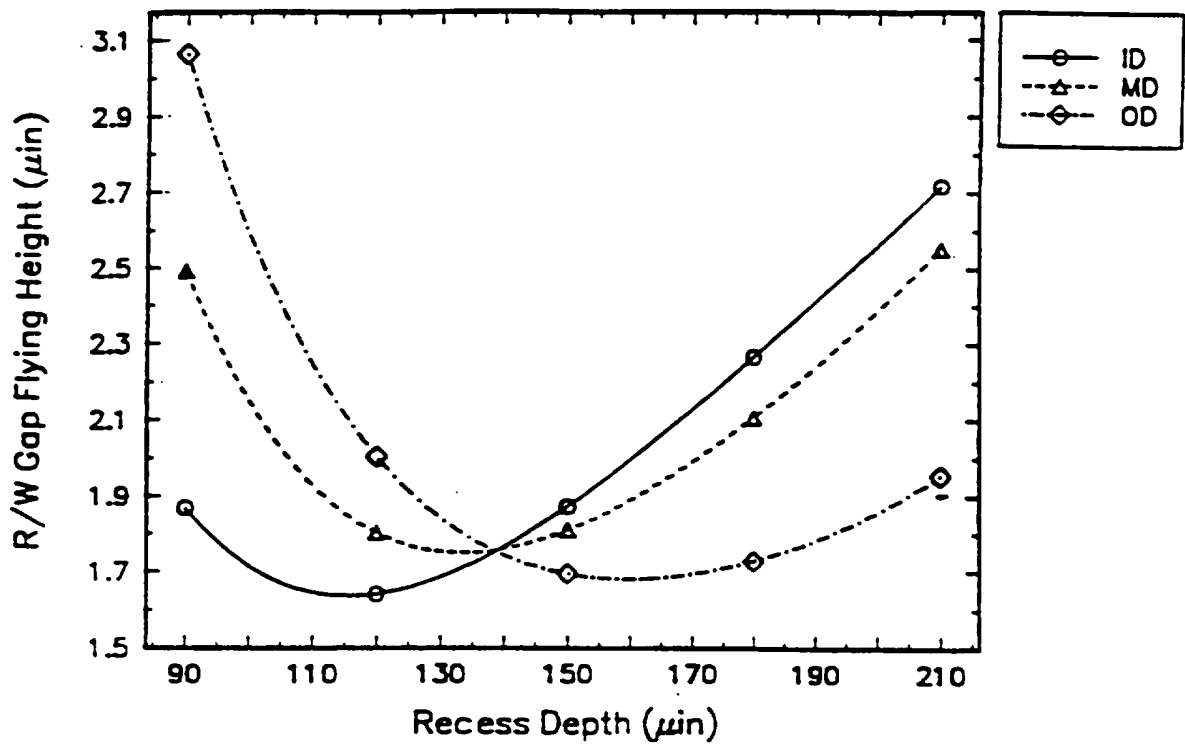

Figure 6

# INTERNATIONAL SEARCH REPORT

Internal Application No  
PCT/US 95/16272

A. CLASSIFICATION OF SUBJECT MATTER  
IPC 6 G11B5/60

According to International Patent Classification (IPC) or to both national classification and IPC

B. FIELDS SEARCHED

Minimum documentation searched (classification system followed by classification symbols)  
IPC 6 G11B

Documentation searched other than minimum documentation to the extent that such documents are included in the fields searched

Electronic data base consulted during the international search (name of data base and, where practical, search terms used)

C. DOCUMENTS CONSIDERED TO BE RELEVANT

| Category * | Citation of document, with indication, where appropriate, of the relevant passages                                  | Relevant to claim No. |
|------------|---|-----------------------|
| X          | EP,A,0 387 444 (DIGITAL EQUIPMENT CORP) 19<br>September 1990  | 24,25                 |
| A          | see the whole document  | 1-23                  |
| A          | ---   |                       |
| A          | EP,A,0 458 444 (SEAGATE TECHNOLOGY) 27<br>November 1991<br>see column 10, line 9 - column 11, line<br>51; figure 11 | 1-25                  |
| A          | ---   |                       |
| A          | EP,A,0 600 348 (READ RITE CORP) 8 June<br>1994<br>see abstract  | 1-25                  |
|            | ---   |                       |
|            | -/--  |                       |

Further documents are listed in the continuation of box C.

Patent family members are listed in annex.

\* Special categories of cited documents :

- \*A\* document defining the general state of the art which is not considered to be of particular relevance
- \*E\* earlier document but published on or after the international filing date
- \*L\* document which may throw doubts on priority claim(s) or which is cited to establish the publication date of another citation or other special reason (as specified)
- \*O\* document referring to an oral disclosure, use, exhibition or other means
- \*P\* document published prior to the international filing date but later than the priority date claimed

- \*T\* later document published after the international filing date or priority date and not in conflict with the application but cited to understand the principle or theory underlying the invention
- \*X\* document of particular relevance; the claimed invention cannot be considered novel or cannot be considered to involve an inventive step when the document is taken alone
- \*Y\* document of particular relevance; the claimed invention cannot be considered to involve an inventive step when the document is combined with one or more other such documents, such combination being obvious to a person skilled in the art.
- \*&\* document member of the same patent family

Date of the actual completion of the international search

25 April 1996

Date of mailing of the international search report

08.05.96

Name and mailing address of the ISA  
European Patent Office, P.B. 5818 Patentlaan 2  
NL - 2280 HV Rijswijk  
Tel. (+ 31-70) 340-2040, Tx. 31 651 epo nl,  
Fax (+ 31-70) 340-3016

Authorized officer  
  
Moyle, J

# INTERNATIONAL SEARCH REPORT

International Application No

PCT/US 95/16272

## C.(Continuation) DOCUMENTS CONSIDERED TO BE RELEVANT

| Category * | Citation of document, with indication, where appropriate, of the relevant passages  | Relevant to claim No. |
|------------|---|-----------------------|
| A          | IEEE TRANSACTIONS ON MAGNETICS,<br>vol. 30, no. 2, 1 March 1994,<br>pages 424-432, XP000473197<br>HARDIE C ET AL: "ANALYSIS AND PERFORMANCE<br>CHARACTERISTICS OF THE SEAGATE ADVANCED<br>AIR BEARING SLIDER"<br>see page 1, right-hand column, paragraph<br>3; figure 1<br>----- | 1-25                  |

1

# INTERNATIONAL SEARCH REPORT

Information on patent family members

International Application No

PCT/US 95/16272

| Patent document cited in search report | Publication date | Patent family member(s) | Publication date |
|--|------------------|-------------------------|------------------|
| EP-A-0387444                           | 19-09-90         | AT-T- 123896            | 15-06-95         |
|  |                  | CA-A- 1323421           | 19-10-93         |
|  |                  | DE-D- 68923078          | 20-07-95         |
|  |                  | DE-T- 68923078          | 30-11-95         |
|  |                  | HK-A- 130995            | 24-08-95         |
|  |                  | JP-A- 2282982           | 20-11-90         |
|  |                  | US-A- 5097370           | 17-03-92         |
|  |                  | US-A- 5309303           | 03-05-94         |
| -----                                  |                  |                         |                  |
| EP-A-0458444                           | 27-11-91         | US-A- 5062017           | 29-10-91         |
|  |                  | JP-A- 4356765           | 10-12-92         |
|  |                  | US-A- 5343343           | 30-08-94         |
| -----                                  |                  |                         |                  |
| EP-A-0600348                           | 08-06-94         | CN-A- 1089382           | 13-07-94         |
|  |                  | JP-A- 6203515           | 22-07-94         |
|  |                  | US-A- 5396387           | 07-03-95         |
| -----                                  |                  |                         |                  |