



US 20180042667A1

(19) **United States**

(12) **Patent Application Publication**  
**Pappone et al.**

(10) **Pub. No.: US 2018/0042667 A1**

(43) **Pub. Date: Feb. 15, 2018**

(54) **THERMAL MAPPING CATHETER**

**Publication Classification**

(71) Applicant: **St. Jude Medical, Cardiology Division, Inc.**, St. Paul, MN (US)  
  
(72) Inventors: **Carlo Pappone**, Cernusco Lombardone (IT); **Alan de la Rama**, Cerritos, CA (US); **Gabriele Giuseppe Vicedomini**, Brisighella (IT); **Cary Hata**, Irvine, CA (US); **Tho Hoang Nguyen**, Huntington Beach, CA (US); **Peter Chen**, Irvine, CA (US)

(51) **Int. Cl.**  
*A61B 18/14* (2006.01)  
*A61B 5/042* (2006.01)  
*A61F 7/12* (2006.01)  
(52) **U.S. Cl.**  
CPC ..... *A61B 18/1492* (2013.01); *A61F 7/123* (2013.01); *A61B 5/0422* (2013.01); *A61B 2018/00797* (2013.01)

(21) Appl. No.: **15/546,991**  
(22) PCT Filed: **Jan. 28, 2016**  
(86) PCT No.: **PCT/US2016/015449**  
§ 371 (c)(1),  
(2) Date: **Jul. 27, 2017**

(57) **ABSTRACT**

A catheter is disclosed comprising a catheter shaft including a proximal end and a distal end. A flexible framework can be connected to the distal end of the catheter shaft, wherein the flexible framework includes a plurality of heating electrodes and a temperature sensor. The plurality of heating electrodes can be configured to be heated to a first temperature, the first temperature being lower than which radio frequency ablation is performed. The plurality of heating electrodes can be configured to be heated to a second temperature, the second temperature being a temperature at which radio frequency ablation is performed.

**Related U.S. Application Data**

(60) Provisional application No. 62/108,945, filed on Jan. 28, 2015.

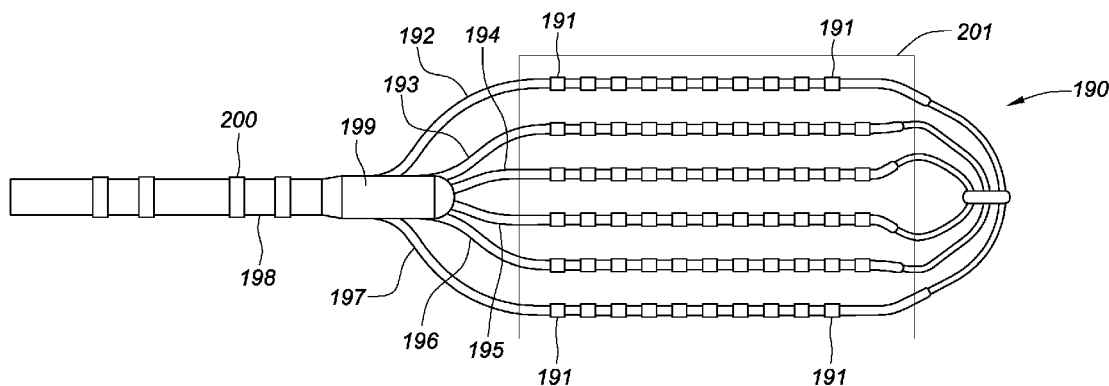

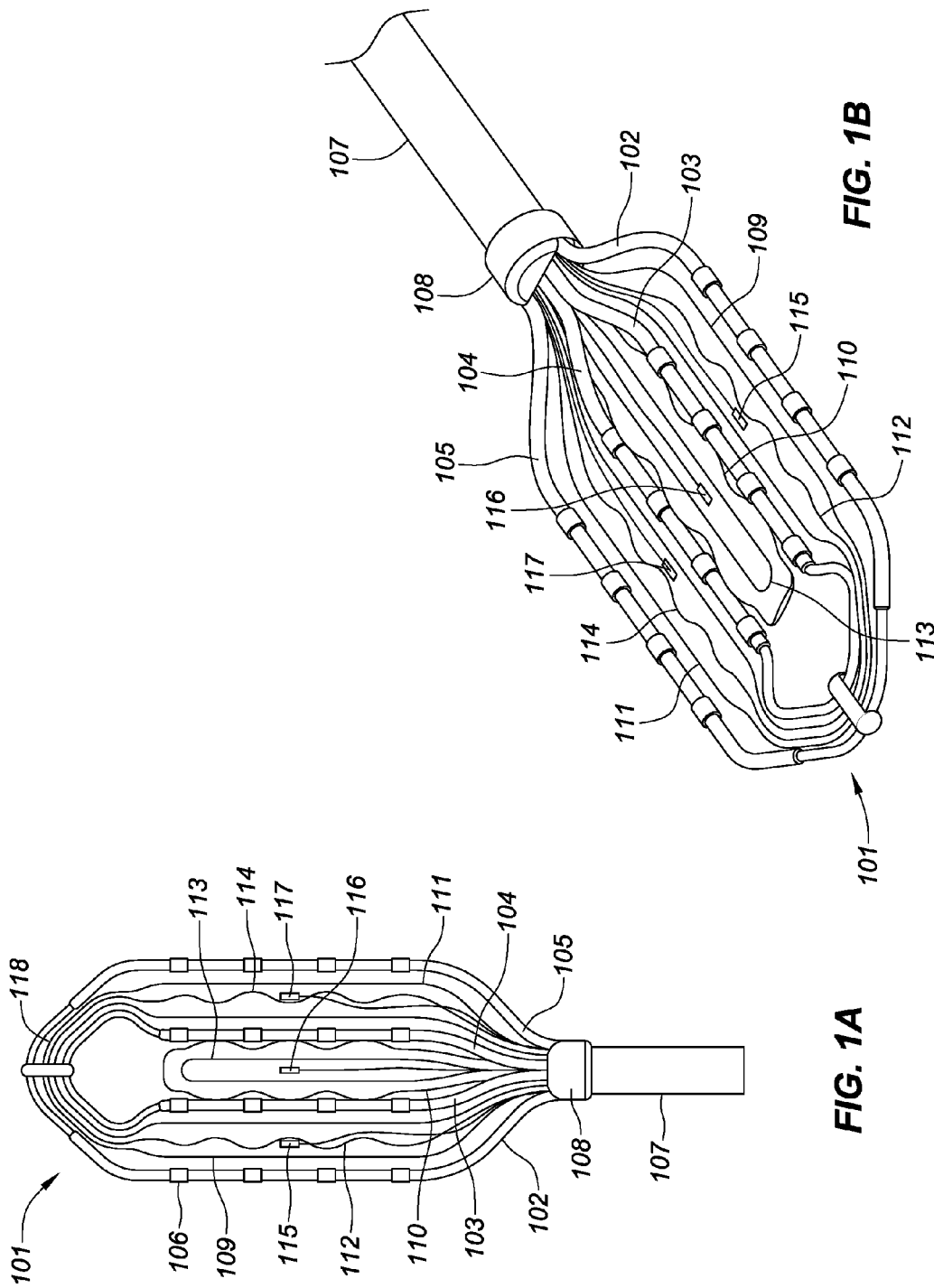

FIG. 1B

FIG. 1A

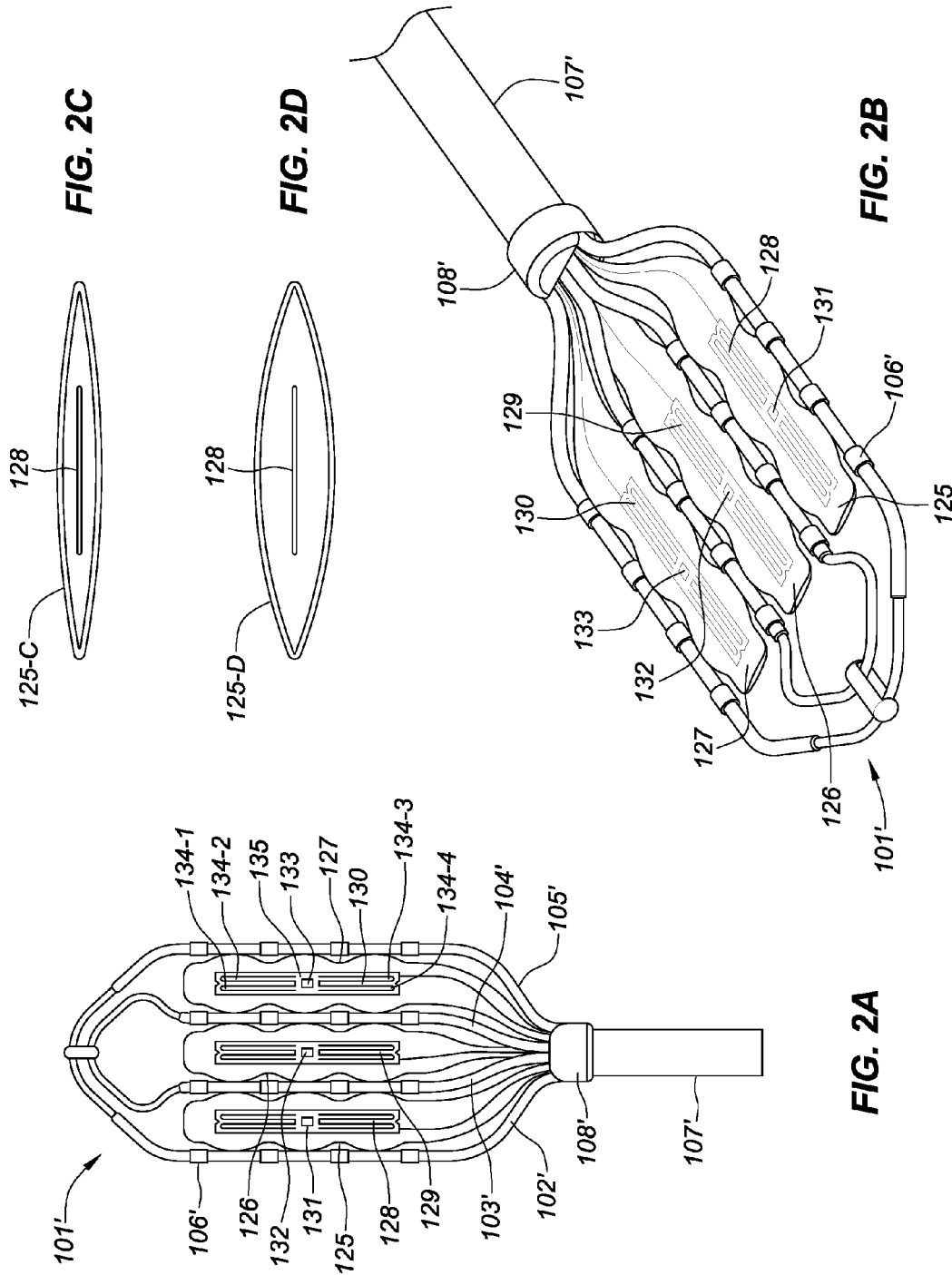

FIG. 2C

FIG. 2D

FIG. 2B

FIG. 2A

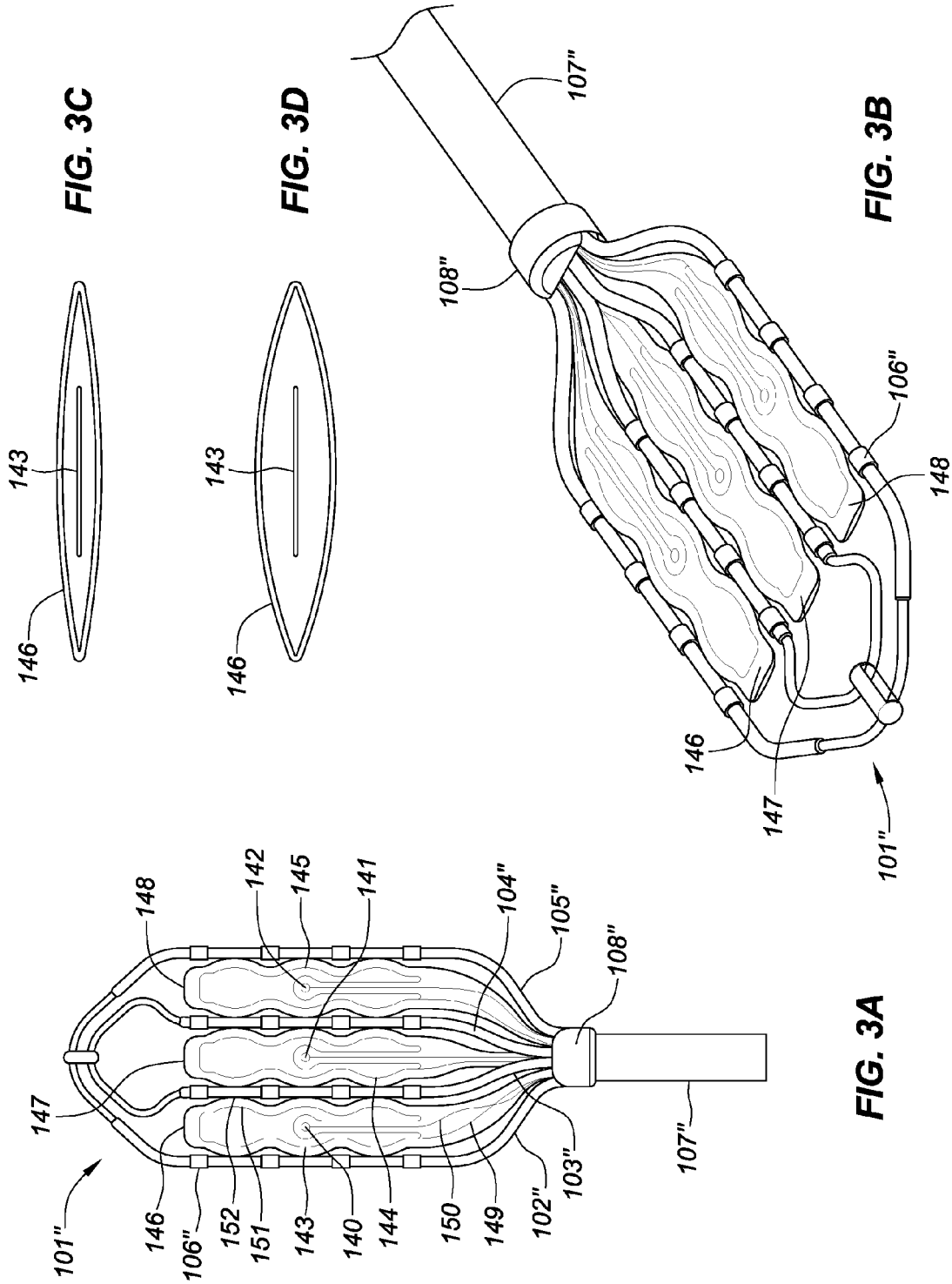

FIG. 3C

FIG. 3D

FIG. 3B

FIG. 3A

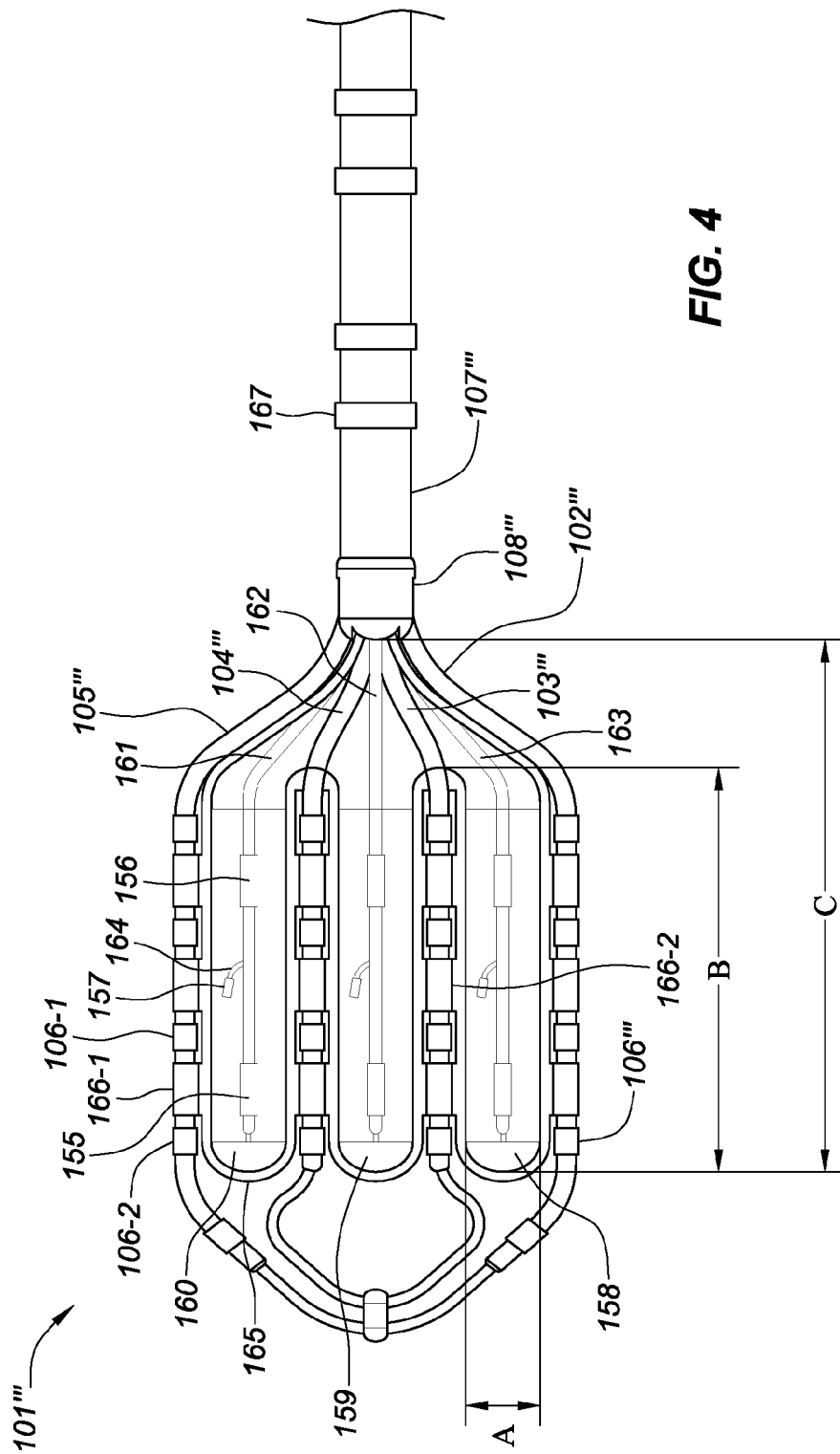
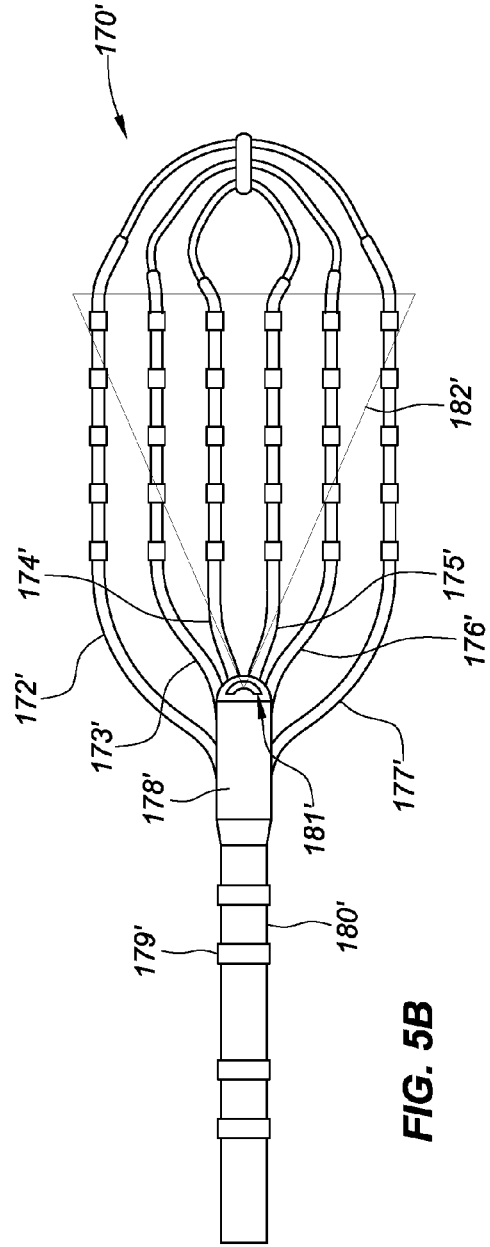
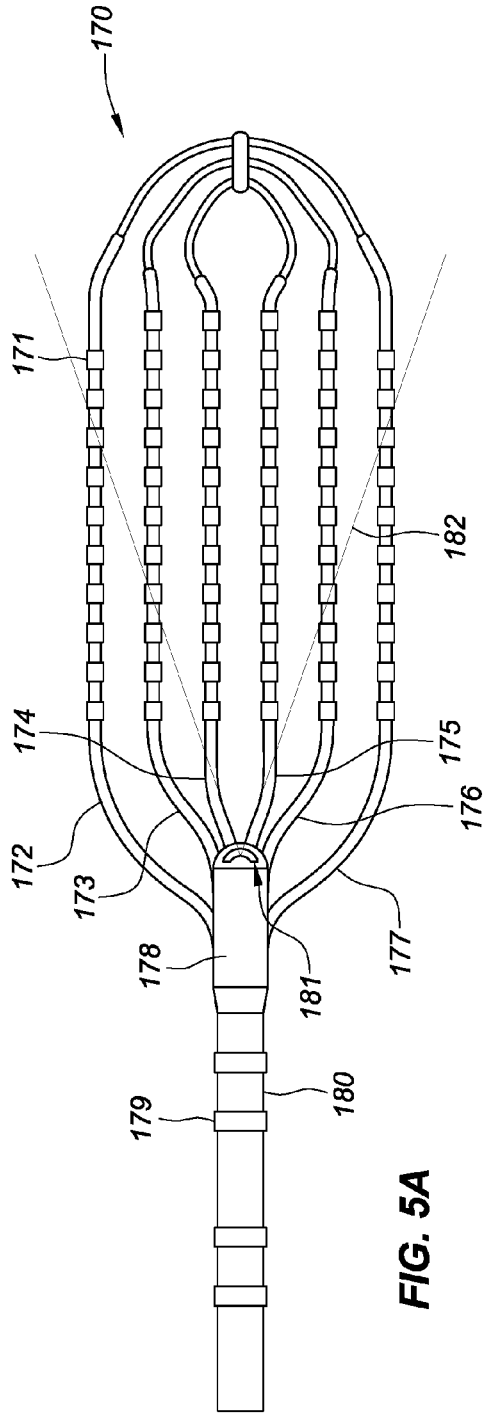

FIG. 4



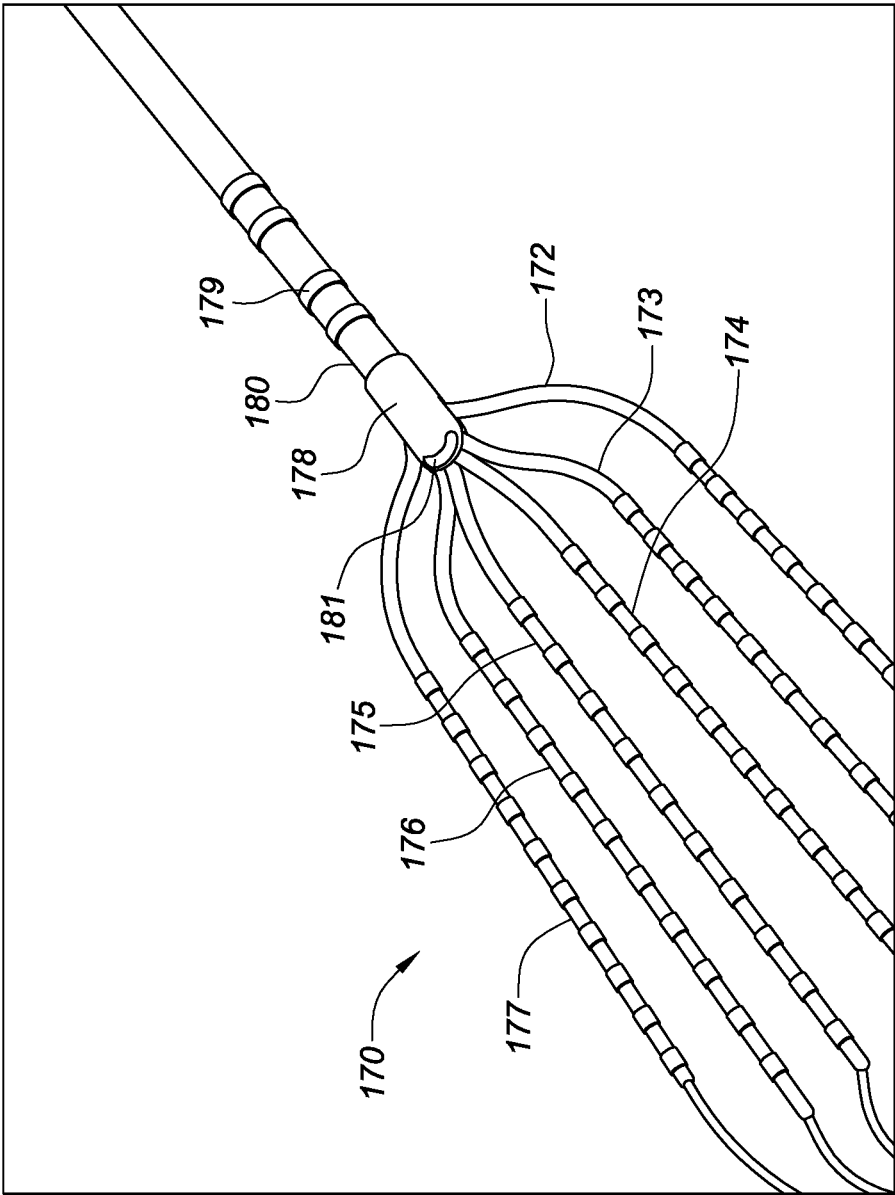

FIG. 5C

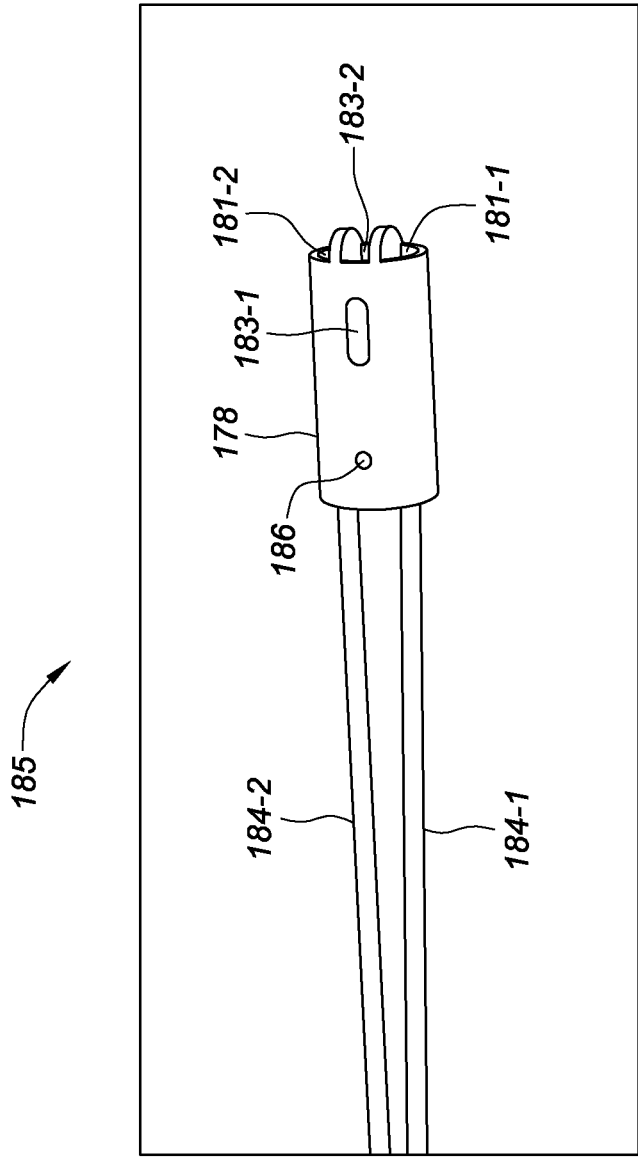
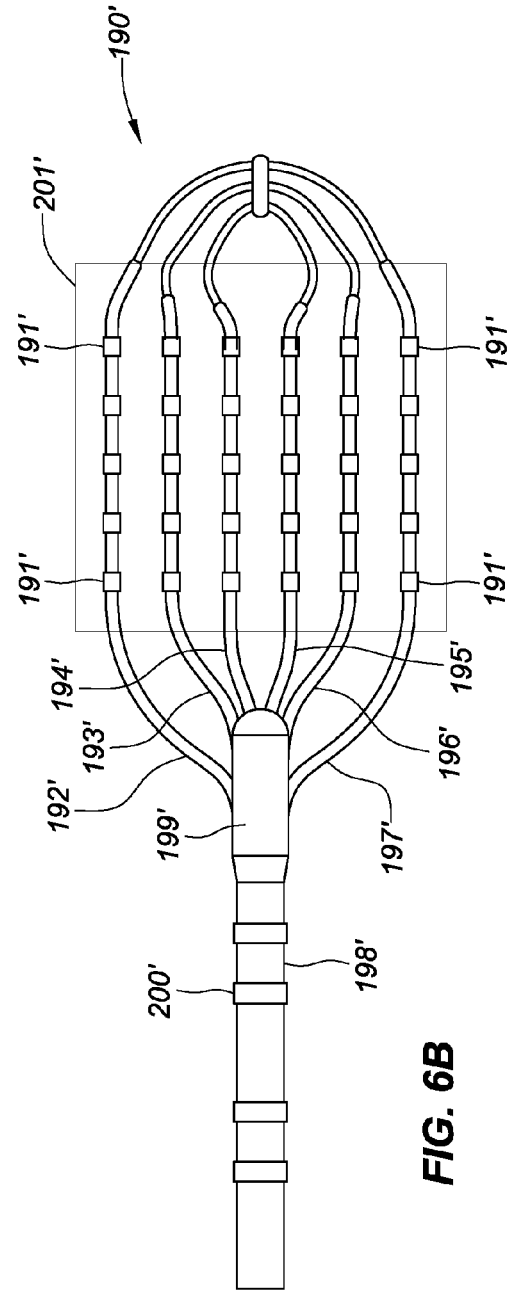
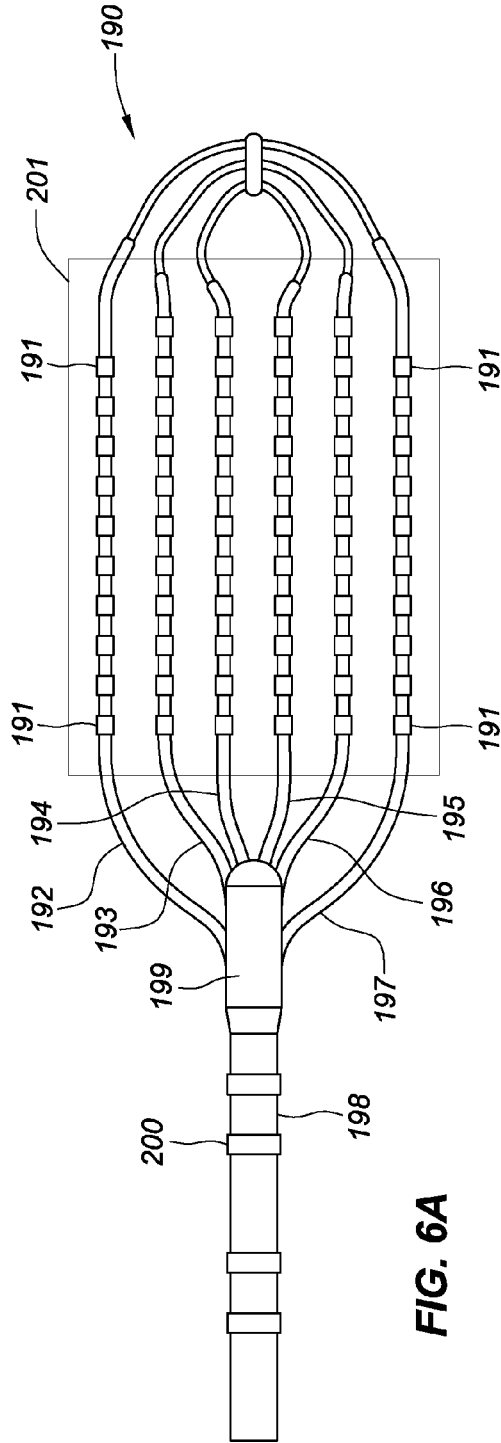
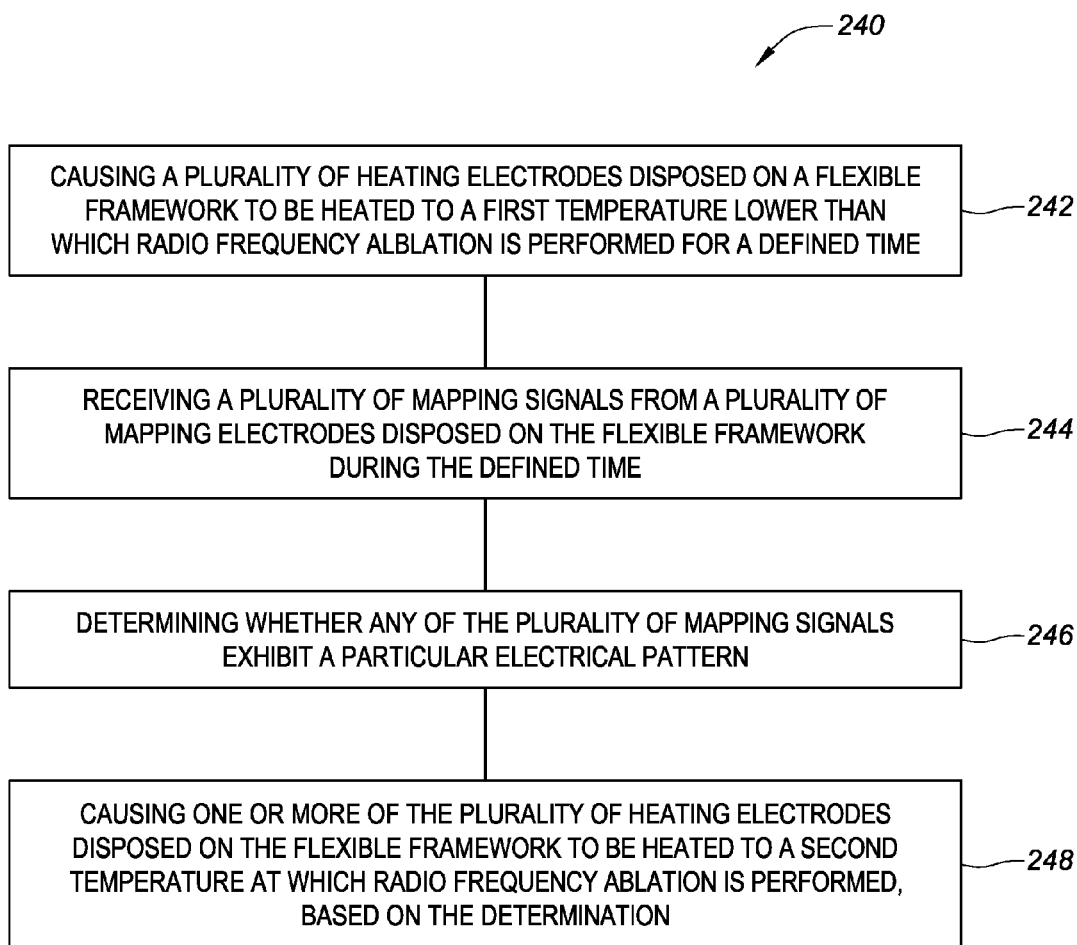

FIG. 5D

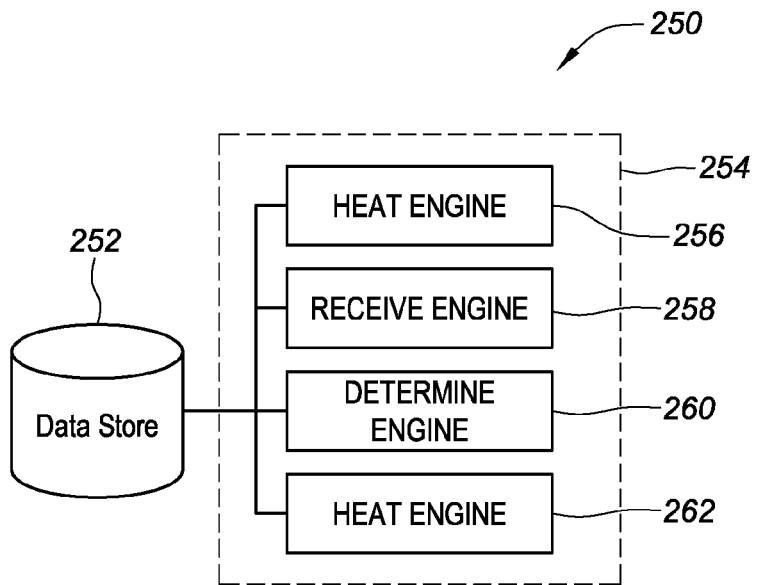



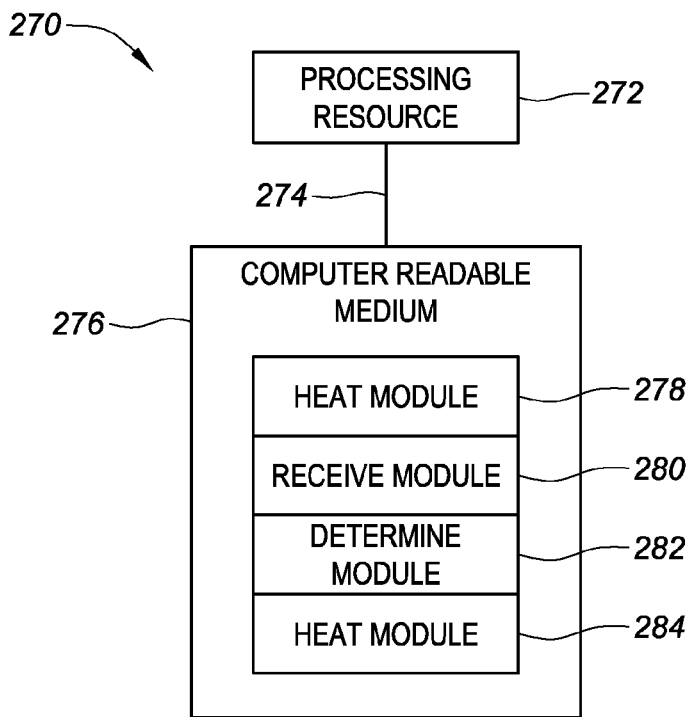



**FIG. 8**



**FIG. 9A**



**FIG. 9B**

## THERMAL MAPPING CATHETER

### CROSS-REFERENCE TO RELATED APPLICATION

[0001] This application claims priority to U.S. provisional patent application No. 62/108,945 entitled "THERMAL MAPPING CATHETER," filed 28 Jan. 2015, which is hereby incorporated by reference as though fully set forth herein.

### A. FIELD OF THE DISCLOSURE

[0002] This disclosure relates to a thermal mapping catheter.

### B. BACKGROUND ART

[0003] Catheters have been used for cardiac medical procedures for many years. Catheters can be used, for example, to diagnose and treat cardiac arrhythmias, while positioned at a specific location within a body that is otherwise inaccessible without a more invasive procedure.

[0004] Conventional mapping catheters may include, for example, a plurality of adjacent ring electrodes encircling the longitudinal axis of the catheter and constructed from platinum or some other metal. These ring electrodes are relatively rigid. Similarly, conventional ablation catheters may comprise a relatively rigid tip electrode for delivering therapy (e.g., delivering RF ablation energy) and may also include a plurality of adjacent ring electrodes. It can be difficult to maintain good electrical contact with cardiac tissue when using these conventional catheters and their relatively rigid (or nonconforming), metallic electrodes, especially when sharp gradients and undulations are present.

[0005] Whether mapping or forming lesions in a heart, the beating of the heart, especially if erratic or irregular, complicates matters, making it difficult to keep adequate contact between electrodes and tissue for a sufficient length of time. These problems are exacerbated on contoured or trabeculated surfaces. If the contact between the electrodes and the tissue cannot be sufficiently maintained, quality lesions or accurate mapping are unlikely to result.

[0006] The foregoing discussion is intended only to illustrate the present field and should not be taken as a disavowal of claim scope.

### BRIEF SUMMARY

[0007] Various embodiments of the present disclosure can include a catheter. The catheter can comprise a catheter shaft including a proximal end and a distal end. A flexible framework can be connected to the distal end of the catheter shaft, wherein the flexible framework includes a plurality of heating electrodes and a temperature sensor. The plurality of heating electrodes can be configured to be heated to a first temperature, the first temperature being lower than which radio frequency ablation is performed. The plurality of heating electrodes can be configured to be heated to a second temperature, the second temperature being a temperature at which radio frequency ablation is performed.

[0008] Various embodiments of the present disclosure can include a catheter. The catheter can comprise a catheter shaft including a proximal end and a distal end. A flexible framework can be connected to the distal end of the catheter shaft. The flexible framework can include a plurality of electrodes disposed thereon. A fluid sac can be connected to

the flexible framework. The fluid sac can include a heater and can be configured to be filled with a fluid.

[0009] Various embodiments of the present disclosure can include a method for thermal mapping and ablation. The method can comprise causing a plurality of heating electrodes disposed on a flexible framework to be heated to a first temperature lower than which radio frequency ablation is performed for a defined time. The method can comprise receiving a plurality of mapping signals from a plurality of mapping electrodes disposed on the flexible framework during a portion of the defined time. The method can comprise determining whether any of the plurality of mapping signals exhibit a particular electrical pattern. The method can comprise causing one or more of the plurality of heating electrodes disposed on the flexible framework to be heated to a second temperature at which radio frequency ablation is performed, based on the determination.

[0010] Various embodiments of the present disclosure can include a catheter. The catheter can comprise a catheter shaft including a proximal end and a distal end. A flexible framework can be connected to the distal end of the catheter shaft, wherein the flexible framework includes a plurality of electrodes disposed thereon. An irrigation channel can extend through the catheter shaft and an irrigation port can be disposed at the distal end of the catheter shaft and can be in fluid communication with the irrigation channel. The catheter can be configured to expel heated fluid from the irrigation port and monitor mapping signals produced by a tissue via the plurality of electrodes disposed on the flexible framework.

### BRIEF DESCRIPTION OF THE DRAWINGS

[0011] FIG. 1A is a top view of a thermal mapping catheter, according to various embodiments of the present disclosure.

[0012] FIG. 1B is an isometric front, side and top view of the thermal mapping catheter depicted in FIG. 1A, according to various embodiments of the present disclosure.

[0013] FIG. 2A is a top view of a second embodiment of a thermal mapping catheter, according to various embodiments of the present disclosure.

[0014] FIG. 2B is an isometric front, side and top view of the second embodiment of the thermal mapping catheter depicted in FIG. 2A, according to various embodiments of the present disclosure.

[0015] FIG. 2C is a cross-sectional front view of a fluid sac of the second embodiment of the thermal mapping catheter, as shown in FIG. 2A, according to various embodiments of the present disclosure.

[0016] FIG. 2D is a cross-sectional front view of a fluid sac of the second embodiment of the thermal mapping catheter, as shown in FIG. 2A, in an expanded state, according to various embodiments of the present disclosure.

[0017] FIG. 3A is a top view of a third embodiment of a thermal mapping catheter, according to various embodiments of the present disclosure.

[0018] FIG. 3B is an isometric front, side and top view of the third embodiment of the thermal mapping catheter depicted in FIG. 3A, according to various embodiments of the present disclosure.

[0019] FIG. 3C is a cross-sectional front view of a fluid sac of the third embodiment of the thermal mapping catheter, as shown in FIG. 3A, according to various embodiments of the present disclosure.

[0020] FIG. 3D is a cross-sectional front view of a fluid sac of the third embodiment of the thermal mapping catheter, as shown in FIG. 3A, in an expanded state, according to various embodiments of the present disclosure.

[0021] FIG. 4 is a top view of a fourth embodiment of a thermal mapping catheter, according to various embodiments of the present disclosure.

[0022] FIG. 5A is a top view of a fifth embodiment of a thermal mapping catheter with a first number of electrodes, according to various embodiments of the present disclosure.

[0023] FIG. 5B is a top view of a fifth embodiment of the thermal mapping catheter with a second number of electrodes, according to various embodiments of the present disclosure.

[0024] FIG. 5C is an isometric front, side and top view of the fifth embodiment of the thermal mapping catheter shown in FIG. 5B, according to various embodiments of the present disclosure.

[0025] FIG. 5D is a side view of an irrigation assembly shown in FIGS. 5A to 5C, according to various embodiments of the present disclosure.

[0026] FIG. 6A is a top view of a sixth embodiment of a thermal mapping catheter with a first number of electrodes, according to various embodiments of the present disclosure.

[0027] FIG. 6B is a top view of a sixth embodiment of the thermal mapping catheter with a second number of electrodes, according to various embodiments of the present disclosure.

[0028] FIG. 7 is a top view of a thermal mapping catheter that includes mapping electrodes, heating electrodes, and thermocouples, according to various embodiments of the present disclosure.

[0029] FIG. 8 depicts a flow diagram associated with a method, according to various embodiments of the present disclosure.

[0030] FIG. 9A depicts a diagram of a system for thermal mapping and ablation, according to embodiments of the present disclosure.

[0031] FIG. 9B depicts a diagram of an example of a computing device for thermal mapping and ablation, according to various embodiments of the present disclosure.

#### DETAILED DESCRIPTION

[0032] The contents of International Application No. PCT/US2014/011940 entitled Flexible High-Density Mapping Catheter Tips and Flexible Ablation Catheter Tips with Onboard High-Density Mapping Electrodes is hereby incorporated by reference.

[0033] In an example, some syndromes can cause ventricular fibrillation, which can lead to health risks and/or death. For instance, syndromes such as Brugada syndrome (BrS) can have a heterogeneous genetic basis with more than 15 different genes involving different channels being described as responsible for a Brugada electrocardiogram (ECG) pattern expression. SCN5A mutations are the most commonly found mutations in 15-30% of patients with BrS, an autosomal-dominant inherited arrhythmic disorder characterized by ST elevation with a successive negative T wave in the right precordial leads with an absence of gross structural abnormalities. Patients with BrS are at risk for sudden cardiac death due to ventricular fibrillation. The SCN5A mutations in BrS are also associated with incomplete penetrance and variable expressivity, and many patients with the mutation never develop symptoms of the

disease. Hence, there is great controversy and difficulty over which patients are likely to develop a life threatening arrhythmia and who may need preventive therapy.

[0034] Diagnosis of BrS requires a high level of suspicion due to a resting ECG that is frequently borderline intermittently normal or frankly normal. Genetic testing is not sensitive and may yield results that are difficult to interpret. Pharmacologic challenge testing with intravenous administration of sodium channel blockers such as flecainide, ajmaline, pilsidainide, and procainamide have been used to unmask the ECG pattern in patients with BrS by provoking ST-segment elevation. However studies have shown that these drugs are far less than 100% sensitive and specific for BrS.

[0035] Fever can play a role for ventricular arrhythmias in patients with sodium channel disorders. Although the exact mechanism remains elusive, one explanation is that mutations associated with BrS changes the temperature sensitivity of fast inactivation of the sodium channel.

[0036] According to embodiments of the present disclosure, in an example, a portion of the heart can be warmed to mimic a rise in body temperature to unmask the Brugada pattern. Some embodiments of the present disclosure can include a thermal mapping catheter that can be configured to warm a portion of the heart and collect electrical signals produced by the heart. Some embodiments of the present disclosure can include a thermal mapping catheter that can be configured to acquire mapping points associated with locations where ablation is to be performed, based on the collection of the electrical signals. Some embodiments of the present disclosure can include a thermal mapping catheter that is configured to ablate tissue (e.g., cardiac tissue).

[0037] Some embodiments of the present disclosure can be used to increase a temperature of cardiac tissue (e.g., epicardial tissue). In some embodiments, the temperature of the cardiac tissue can be increased after a sodium blocker infusion (e.g., flecainide, ajmaline, pilsidainide, procainamide infusion) has been performed. A detailed electroanatomical voltage map (e.g., epicardial voltage map) can be created using embodiments of the present disclosure to collect electrical signals from the tissue, which can then be assembled into the electroanatomical voltage map.

[0038] FIG. 1A is a top view of a thermal mapping catheter 101 and FIG. 1B is an isometric front, side and top view of the thermal mapping catheter 101, according to various embodiments of the present disclosure. In some embodiments, the thermal mapping catheter 101 can include a flexible array of microelectrodes. This planar array (or 'paddle' configuration) of microelectrodes comprises four side-by-side, longitudinally-extending arms 102, 103, 104, 105, which can form a flexible framework on which ring electrodes 106 are carried. The four ring-electrode-carrier arms comprise a first outboard arm 102, a second outboard arm 105, a first inboard arm 103, and a second inboard arm 104. These arms can be laterally separated from each other. Each of the four arms can carry a plurality of ring electrodes 106. For example, each of the four arms can carry ring electrodes 106 spaced along a length of each of the four arms. Although the paddle catheter depicted in FIGS. 1A and 1B include four arms, the paddle could comprise more or fewer arms.

[0039] In some embodiments, the thermal mapping catheter 101 can include a catheter shaft 107. The catheter shaft 107 can include a proximal end and a distal end. The distal

end can include a connector **108**, which can couple the distal end of the catheter shaft **107** to a proximal end of the planar array (e.g., flexible framework). The catheter shaft **107** can be made of a flexible material, such that it can be threaded through a tortuous vasculature of a patient.

**[0040]** In some embodiments, fluid sacs can be disposed between the first outboard arm **102** and the first inboard arm **103**, between the first inboard arm **103** and the second inboard arm **104**, and between the second inboard arm **104** and the second outboard arm **105**. In an example, the fluid sacs can extend from the proximal end of the planar array to a distal end of the planar array. For instance, a first fluid sac **109** can be disposed between the first outboard arm **102** and the first inboard arm **103**, a second fluid sac **110** can be disposed between the first inboard arm **103** and the second inboard arm **102**, and a third fluid sac **111** can be disposed between the second inboard arm **104** and the second outboard arm **105**. In some embodiments, one or more fluid sacs can be disposed between at least a pair of the longitudinally-extending arms **102**, **103**, **104**, **105**.

**[0041]** In some embodiments, the fluid sacs can be formed of a flexible material such as a rubber (e.g., latex) and/or a plastic. Further, the arms (or the understructure of the arms) comprising the paddle structure (or multi-arm, electrode-carrying, flexible framework) at the distal end of the catheter are preferably constructed from a flexible or spring-like material such as Nitinol. The construction (including, for example, the length and/or diameter of the arms and/or length and/or thickness of the fluid sacs) and material of the arms and/or fluid sacs can be adjusted or tailored to be created, for example, desired resiliency, flexibility, foldability, conformability, and stiffness characteristics, including one or more characteristics that may vary from the proximal end of a single arm to the distal end of that arm, or between or among the plurality of arms comprising a single paddle structure. In an example, the thermal mapping catheter **101** can be folded to allow insertion through a vasculature of a patient, in some embodiments. The foldability of the materials from which the materials that the catheter is formed from provide the additional advantage of facilitating insertion of the paddle structure into a delivery catheter or introducer, whether during delivery of the catheter into the body or removal of the catheter from the body at the end of a procedure.

**[0042]** In some embodiments, the fluid sacs can include heaters **112**, **113**, **114**. The heaters **112**, **113**, **114** can be formed from a conductive flexible wire. In an example, electricity can be supplied to the flexible wire, which can resistively heat the wire. The heat from the heaters **112**, **113**, **114** can be transferred, to the fluid included in the fluid sacs **109**, **110**, **111**. In an example, the fluid can be a saline solution. In some embodiments, each of the fluid sacs **109**, **110**, **111** can include temperature sensors **115**, **116**, **117** (e.g., thermocouples). The temperature sensors **115**, **116**, **117** can be attached to an inside of each of the fluid sacs **109**, **110**, **111** and can be in fluid communication with the fluid included in each of the fluid sacs **109**, **110**, **111**. The temperature of the fluid can thus be sensed by the temperature sensors **115**, **116**, **117** and a signal produced by the temperature sensors can be used to control heating of the fluid by the heaters. In some embodiments, the fluid can be heated to a temperature in a range of 50 degrees Celsius to 60 degrees Celsius. However, the fluid can be heated to a temperature less than 50 degrees Celsius and/or greater than

a temperature of 60 degrees Celsius in some embodiments. In some embodiments, the fluid can be heated to a temperature of 40 degrees Celsius to 60 degrees Celsius. In some embodiments, the fluid can be heated to a temperature of 40 degrees Celsius to 48 degrees Celsius. In some embodiments, the fluid can be heated to a temperature in a range of 35 degrees Celsius to 65 degrees Celsius. In some embodiments, the fluid can be heated to a temperature in a range from 38 degrees Celsius to 42 degrees Celsius. Upon contact between the fluid sacs **109**, **110**, **111** and the tissue, the tissue can be warmed, which can help unmask the Brugada pattern. In some embodiments, the tissue can be warmed via the fluid sacs **109**, **110**, **111** to a temperature in a range from 38 degrees Celsius to 42 degrees Celsius, which can cause the tissue to exhibit an ECG pattern recognizable as the Brugada pattern. However, in some embodiments, the tissue can be warmed to a temperature greater than 42 degrees Celsius. For example, in some embodiments, the tissue can be heated to a temperature in a range from 38 degrees Celsius to 45 degrees Celsius, 38 degrees Celsius to 50 degrees Celsius, 42 degrees Celsius to 48 degrees Celsius, and/or 42 degrees Celsius to 50 degrees Celsius. In some embodiments, when heating the tissue to an upper range within the above and below noted ranges to cause the tissue to exhibit the ECG pattern recognizable as the Brugada pattern, the tissue can be momentarily heated to that temperature to avoid damage to the tissue.

**[0043]** Electrical signals can be collected from the tissue via the electrodes **106**. The tissue can then also be ablated with the electrodes **106**, in some embodiments, by heating the electrodes to a temperature associated with the performance of ablation, as discussed herein. In some embodiments, the heaters **112**, **113**, **114**, the temperature sensors **115**, **116**, **117**, and/or electrodes **106** can be controlled via a system and/or computing device discussed in relation to FIGS. 9A and 9B.

**[0044]** In some embodiments, the fluid sacs **109**, **110**, **111** can be in fluid communication with one or more supply tubes that extend through the catheter shaft. In an example, a proximal end of each of the fluid sacs **109**, **110**, **111** can be in fluid communication with the one or more supply tubes. The thermal mapping catheter **101** can include a fluid pump, for example, at a proximal end of the thermal mapping catheter **101** (e.g., in a catheter handle, proximal to the catheter handle) that is configured to pump fluid through the one or more supply tubes into the fluid sacs **109**, **110**, **111**. The fluid can be static or dynamic. For example, the fluid that the fluid sacs **109**, **110**, **111** are filled with can remain stationary, and/or can be circulated through each of the fluid sacs **109**, **110**, **111**.

**[0045]** In an example, the fluid sacs **109**, **111** can be in fluid communication with one another. For example, the fluid sacs **109**, **111** can be in fluid communication via a fluid conduit **118**. Fluid can be fed into one of the fluid sacs **109**, **111**, and returned through the other fluid sac. For example, fluid can be fed into fluid sac **109** and returned through fluid sac **111**. Alternatively, fluid can be fed into fluid sac **111** and returned through fluid sac **109**.

**[0046]** In some embodiments, the fluid sacs **109**, **110**, **111** can be connected to the arms **102**, **103**, **104**, **105**. For example, the first fluid sac **109** can be connected to the first outboard arm **102** and the first inboard arm **103**, the second fluid sac **110** can be connected to the first inboard arm **103** and the second inboard arm **104**, and the third fluid sac can

be connected to the second inboard arm **104** and the second outboard arm **105**. In an example, each of the fluid sacs **109**, **110**, **111** can be connected to one another via connection tabs, as further illustrated in FIG. 4.

[0047] In some embodiments, a width of the fluid sacs **109**, **110**, **111** can be configured to fit between each of the arms. For example, a width of the fluid sac **109** can be configured to fit between the first outboard arm **102** and the first inboard arm **103**; a width of the second fluid sac **110** can be configured to fit between the first inboard arm **103** and the second inboard arm **104**; and a width of the third fluid sac **111** can be configured to fit between the second inboard arm **104** and the second outboard arm **111**. In some embodiments, as further discussed in relation to FIGS. 3C and 3D, a height of the fluid sacs **109**, **110**, **111** in a filled state can be configured to be less than a height of each of the respective arms **102**, **103**, **104**, **105**.

[0048] FIG. 2A is a top view of a second embodiment of a thermal mapping catheter **101'**. The thermal mapping catheter **101'** can include longitudinally extending arms **102'**, **103'**, **104'**, **105'**, which can form the flexible framework on which ring electrodes **106'** are carried. The thermal mapping catheter **101'** can also include the catheter shaft **107'** and the connector **108'**. The thermal mapping catheter **101'** can include fluid sacs **125**, **126**, **127**, as discussed in relation to FIG. 1A. In some embodiments, the fluid sacs **125**, **126**, **127** can be individual fluid sacs (i.e., not connected to one another). For example, the fluid sacs **125**, **127** can be separate from one another and not in fluid communication with one another via the fluid conduit **118**, as discussed in relation to FIG. 1A.

[0049] In some embodiments, the thermal mapping catheter **101'** can include flexible circuits **128**, **129**, **130**, which can serve as heating elements to heat the fluid. In some embodiments, the flexible circuits can include temperature sensors **131**, **132**, **133**, as discussed in relation to FIG. 1A. The flexible circuits can be folded in some embodiments. In an example, as the thermal mapping catheter **101'** is collapsed and the longitudinally-extending arms **102'**, **103'**, **104'**, **105'** move closer to one another, the flexible circuits can be folded longitudinally, such that a lateral width of the folded circuits is reduced. For instance, the flexible circuits **128**, **129**, **130** can be folded in half lengthwise, along a longitudinal axis of each respective flexible circuit **128**, **129**, **130**, such that a width of each one of the flexible circuits **128**, **129**, **130** is decreased when the thermal mapping catheter **101'** is in an undeployed state.

[0050] In some embodiments, as depicted in FIG. 2A with respect to flexible circuit **130**, the flexible circuit **130** can include one or more longitudinally and distally extending heater elements (e.g., distal heater elements **134-1**, **134-2**) and one or more longitudinally and proximally extending heater elements (e.g., proximal heater elements **134-3**, **134-4**) that extend from a heater element bus **135**. In some embodiments, the distal heater elements **134-1**, **134-2** and the proximal heater elements **134-3**, **134-4** can be electrically coupled via the heater bus **135**. The heater elements **134-1**, **134-2**, **134-3**, **134-4** can be formed on a substrate, in some embodiments, such as a printed circuit board (PCB) and can be electrically coupled to a power source via one or more leads electrically coupled to the flexible circuit that extend through the catheter shaft **107'**. Although flexible

heater circuit **130** is discussed, the flexible circuits **128**, **129** can include features similar to those discussed in relation to flexible heater circuit **130**.

[0051] As previously discussed, in some embodiments, the fluid can be heated to a temperature in a range of 50 degrees Celsius to 60 degrees Celsius. However, the fluid can be heated to a temperature less than 50 degrees Celsius and/or greater than a temperature of 60 degrees Celsius. In some embodiments, the fluid can be heated to a temperature of 40 degrees Celsius to 60 degrees Celsius. In some embodiments, the fluid can be heated to a temperature of 40 degrees Celsius to 48 degrees Celsius. In some embodiments, the fluid can be heated to a temperature in a range of 35 degrees Celsius to 65 degrees Celsius. In some embodiments, the fluid can be heated to a temperature in a range from 38 degrees Celsius to 42 degrees Celsius.

[0052] FIG. 2B is an isometric front, side and top view of the second embodiment of the thermal mapping catheter **101'** depicted in FIG. 2A. In an example, FIGS. 2C and 2D depict the cross-section of fluid sac **125-C**, **125-D** and the flexible circuit **128**. Fluid sacs **126**, **127** can include features similar to those discussed in relation to fluid sac **125**. The cross-section (e.g., width and/or height) of fluid sacs **126**, **127** can be the same, smaller, or larger than the cross-section of fluid sac **125**. FIG. 2C depicts the cross-section of the fluid sac **125-C** when the fluid sac **125-C** is partially filled with the fluid. For example, the fluid sac **125-C** is depicted as partially expanded in FIG. 2C. FIG. 2D depicts the cross-section of the fluid sac **125-D** when the fluid sac **125-D** is filled to an extent that is greater than that depicted in FIG. 2C. As the fluid sac **125** is filled, the fluid sac **125** can expand, such that a cross-section of the fluid sac **125** forms an oblong shape. In an example, the fluid sac **125** can be filled such that a height of the fluid sac **125** is less than that of the electrodes **106'**. Alternatively, the fluid sac **125** can be filled such that a height of the fluid sac **125** is equal to the height of the electrodes **106'** and/or is greater than the height of the electrodes **106'**.

[0053] FIG. 3A is a top view of a third embodiment of the thermal mapping catheter **101"**. The thermal mapping catheter **101"** can include longitudinally extending arms **102"**, **103"**, **104"**, **105"**, which can form the flexible framework on which ring electrodes **106"** are carried. The thermal mapping catheter **101"** can also include the catheter shaft **107"** and the connector **108"**. The thermal mapping catheter **101"** can include fluid sacs **146**, **147**, **148**, as discussed in relation to FIG. 1A. In some embodiments, the thermal mapping catheter **101"** can include a thin film heating element **143**, **144**, **145**. In an example, the thin film heating element can include a thin film layer, which in some embodiments can be a layer formed from silicon. In some embodiments, a conductive layer can be disposed on the thin film, which can form the heating element. For example, the conductive layer can be deposited on the thin film via a deposition process, such as thermal deposition and/or chemical deposition. In some embodiments, the conductive layer can be metal and can be formed in a particular pattern on the thin film. In some embodiments, a temperature sensor **140**, **141**, **142** can be placed on the film and configured to sense a temperature of the fluid.

[0054] In some embodiments, as depicted in FIG. 3A with reference to thin film heating element **143**, an electrical lead **149** can connect the thin film heating element **143** to an electrical source or one or more computers comprising a



processor and memory storing non-transitory computer-readable instructions executable by the processor and a thermocouple electrical lead 150 can connect the thermocouple 140 to an electrical source and/or the one or more computers, for example such as those discussed in relation to FIGS. 9A and/or 9B.

[0055] In some embodiments, as depicted in FIGS. 3A, 3C, and 3D, the thin film heating elements 143, 144, 145 can be planar. The thin film heating elements 143, 144, 145 can be configured to conform to a shape of each one of the fluid sacs 146, 147, 148. With particular reference to thin film heating element 143 and fluid sac 146, the thin film heating element can include flared portions (e.g., flared portion 151), in some embodiments, which conform to points where the fluid sac 146 is attached to the arms (e.g., first inboard arm 103"). Accordingly, by conforming a shape of the thin film heating elements 143, 144, 145 to a shape of a respective one of the fluid sacs 146, 147, 148, fluid contained in each of the fluid sacs 146, 147, 148 can be more uniformly heated. In some embodiments, the thin film heating elements 143, 144, 145 can be connected with a respective one of the fluid sacs 146, 147, 148. For example, the thin film heating elements 143, 144, 145 can be adhered to a wall of a respective one of the fluid sacs 146, 147, 148, with an adhesive. Thus, as the thermal mapping catheter transitions from an undeployed state to a deployed state, the fluid sacs 146, 147, 148 can expand, along with the thin film heating elements 143, 144, 145.

[0056] As previously discussed, in some embodiments, the fluid can be heated to a temperature in a range of 50 degrees Celsius to 60 degrees Celsius. However, the fluid can be heated to a temperature less than 50 degrees Celsius and/or greater than a temperature of 60 degrees Celsius. In some embodiments, the fluid can be heated to a temperature of 40 degrees Celsius to 60 degrees Celsius. In some embodiments, the fluid can be heated to a temperature of 40 degrees Celsius to 48 degrees Celsius. In some embodiments, the fluid can be heated to a temperature in a range of 35 degrees Celsius to 65 degrees Celsius. In some embodiments, the fluid can be heated to a temperature in a range from 38 degrees Celsius to 42 degrees Celsius.

[0057] In some embodiments, the tissue can be warmed via the fluid sacs 146, 147, 148 to a temperature in a range from 38 degrees Celsius to 42 degrees Celsius, which can cause the tissue to exhibit an ECG pattern recognizable as the Brugada pattern. However, in some embodiments, the tissue can be warmed to a temperature greater than 42 degrees Celsius. For example, in some embodiments, the tissue can be heated to a temperature in a range from 38 degrees Celsius to 45 degrees Celsius, 38 degrees Celsius to 50 degrees Celsius, 42 degrees Celsius to 48 degrees Celsius, and/or 42 degrees Celsius to 50 degrees Celsius.

[0058] FIG. 3B is an isometric front, side and top view of the third embodiment of the thermal mapping catheter 101" depicted in FIG. 3A. In some embodiments, the fluid sacs 146, 147, 148 can be attached to the longitudinally extending arms 102", 103", 104", 105". In an example, as the flexible framework is expanded, the fluid sacs 146, 147, 148 can also be expanded and filled with the fluid.

[0059] In an example, FIGS. 3C and 3D depict the cross-section of fluid sac 146 and the flexible circuit 143. The cross-section of fluid sacs 147, 148 can be the same, smaller, or larger than the cross-section of fluid sac 146. FIG. 2C depicts the cross-section of the fluid sac 146 when the fluid

sac 146 is partially filled with the fluid. For example, the fluid sac 146 is depicted as partially expanded in FIG. 3C. FIG. 3D depicts the cross-section of the fluid sac 146 when the fluid sac 146 is filled to an extent that is greater than that depicted in FIG. 3C. As the fluid sac 146 is filled, the fluid sac 146 can expand, such that a cross-section of the fluid sac 146 forms an oblong shape. In an example, the fluid sac 146 can be filled such that a height of the fluid sac 146 is less than that of the electrodes 106".

[0060] FIG. 4 is a top view of a fourth embodiment of a thermal mapping catheter. The thermal mapping catheter 101" can include longitudinally extending arms 102", 103", 104", 105", which can form the flexible framework on which ring electrodes 106" are carried. The thermal mapping catheter 101" can also include the catheter shaft 107" and the connector 108". In some embodiments, the catheter shaft 107" can include one or more ring electrodes 167. The thermal mapping catheter 101" can include fluid sacs 158, 159, 160, as discussed in relation to FIG. 1A.

[0061] In some embodiments, each fluid sac 158, 159, 160 can include a heating and temperature sensing assembly. In an example, each heating and temperature sensing assembly can include a proximal electrode 156 and a distal electrode 155, which use a bipolar radio frequency (RF) technique to heat the fluid included in each fluid sac 158, 159, 160. In an example, a temperature sensor 157 can be mounted between the proximal electrode 156 and the distal electrode 155. The fluid in the fluid sacs 158, 159, 160 can be heated to a temperature in a range such as that previously discussed herein. In some embodiments, the tissue can be heated to a temperature in a range such as that previously discussed herein via the fluid sacs 158, 159, 160.

[0062] In some embodiments, the proximal electrode 156, the distal electrode 155, and the temperature sensor 157 can be mounted on a support structure 161. Other support structures (e.g., support structures 162, 163) can support additional temperature sensors and thermocouples disposed in the fluid sacs 159, 158. In an example, with particular reference to the support structure 161, the structure can be formed from a non-conductive material, such that each electrode 155, 156 is insulated from one another. In some examples, the support structure 161 can be a wire made of nitinol. In some embodiments, the support structure 161 can be a tube through which wires run to provide electrical connections to the proximal electrode 156, distal electrode 155, and the temperature sensor 157. Alternatively, the wires can run along the outside of the support structure 161. In some embodiments, an irrigation pathway can run through the support structure 161 and can be configured to provide fluid to the fluid sacs 158, 159, 160.

[0063] In some embodiments, the temperature sensor 157 can be disposed off-axis with respect to the support structure 161. In an example, an off-axis thermocouple lead and/or tube 164 that houses a lead can extend from the support structure 161 and can electromechanically couple the temperature sensor 157.

[0064] In some embodiments, a width of the inside of each fluid sac, defined by line A can be approximately 2.25 millimeters (mm), although the width can be smaller or larger than 2.25 mm. In some embodiments, a length of each fluid sac, defined by line B, can be approximately 15.5 mm, although the length can be smaller or larger than 15.5 mm. In some embodiments, a length of each fluid sac between the distal end of each fluid sac to the distal end of the connector

108", defined by line C can be approximately 20.5 mm, although the length can be smaller or larger than 20.5 mm.

[0065] In some embodiments, as depicted in FIG. 4, the thermal mapping catheter 101" can include a fluid sac support structure 165. In an example, the fluid sac support structure 165 can be a unitary piece of material, a first end of which extends distally from a distal end of the connector 108" and extends along an inner surface of the first outboard arm 102". A distal end of the fluid sac support structure 165 can extend towards the first inboard arm 103" and proximally along an outer surface of the first inboard arm 103" before crossing over a proximal portion of the first inboard arm 103" and extending distally along an inner surface of the first inboard arm 103". The support structure 165 can repeat this pattern along the inner and/or outer surfaces of the second inboard arm 104" and second outboard arm 105". In some embodiments, the support structure can be located within the fluid sacs 158, 159, 160 and can aid in expansion of the fluid sacs 158, 159, 160 upon deployment of the thermal mapping catheter 101". In some embodiments, the fluid sacs 158, 159, 160 can include one or more fluid sac mounting portions (e.g., fluid sac mounting portions 166-1, 166-2). The fluid sac mounting portions 166-1, 166-2 can connect the fluid sacs 158, 159, 160 to one or more of the first outboard arm 102", first inboard arm 103", second inboard arm 104", and second outboard arm 105". In an example, each fluid sac 158, 159, 160 can include one or more fluid sac mounting portions 166-1, 166-2 that can be configured to connect the fluid sacs 158, 159, 160 to the arms. In some embodiments, each fluid sac mounting portion 166-1, 166-2 can be a band of material that encircles a portion of a respective arm. For example, fluid sac mounting portion 166-1 can encircle the second outboard arm 105" along a portion of the arm located between electrodes 106-1, 106-2. In some embodiments, the fluid sac mounting portion can be formed from a same material that forms the fluid sacs and the fluid sacs and mounting portion can be unitary in construction.

[0066] In some embodiments, fluid sac mounting portion 166-2 can connect adjacent fluid sacs (e.g., fluid sacs 158, 159) to an arm (e.g., first inboard arm 103"). In an example, the fluid sac mounting portion 166-2 can be connected to both of the fluid sacs 158, 159 and can encircle the first inboard arm located between the fluid sacs 158, 159. The fluid sac mounting portion 166-2 can encircle a portion of the first inboard arm 103" located between electrodes disposed on the first inboard arm 103", as previously discussed. In some embodiments, the fluid sacs 158, 159, 160 can be connected to one another at a proximal portion of the fluid sacs, as depicted in FIG. 4. Because the fluid sacs 158, 159, 160 are proximally connected, the fluid sacs 158, 159, 160 can be in fluid communication with each other. In some embodiments, a distal end of the connector 108" can include a fluid lumen that is in fluid communication with the fluid sacs 158, 159, 160 and can be configured to transfer fluid into or out of the fluid sacs 158, 159, 160.

[0067] FIG. 5A is a top view of a fifth embodiment of a thermal mapping catheter 170 with a first number of electrodes. The thermal mapping catheter 170 can include longitudinally extending arms 172, 173, 174, 175, 176, 177, which can form the flexible framework on which ring electrodes 171 are carried. In some embodiments, the flexible framework can include 64 electrodes 171. Although 64 electrodes are depicted, greater than or fewer than 64

electrodes can be disposed on the flexible framework. The thermal mapping catheter 170 can also include the catheter shaft 180 and the connector 178. In some embodiments, the catheter shaft 180 can include one or more ring electrodes 179.

[0068] In some embodiments, the catheter shaft 180 can include an irrigation channel, which is in fluid communication with an irrigation port 181. In an example, fluid 182 (e.g., saline solution), can travel through the irrigation channel and can be expelled through the irrigation port 181. In an example, the fluid 182 can be heated before the fluid 182 is expelled through the irrigation port 181 or can be heated as the fluid 182 passes through the port 181. The fluid 182 can be heated to a temperature in a range such as that previously discussed in relation to FIGS. 1-4. For example, the fluid 182 can be heated to a temperature in a range from 50 degrees Celsius to 60 degrees Celsius. However, the fluid can be heated to a temperature less than 50 degrees Celsius and/or greater than a temperature of 60 degrees Celsius. In some embodiments, the fluid can be heated to a temperature in a range from 40 degrees Celsius to 60 degrees Celsius. In some embodiments, the fluid can be heated to a temperature in a range from 40 degrees Celsius to 48 degrees Celsius. In some embodiments, the fluid can be heated to a temperature in a range from 35 degrees Celsius to 65 degrees Celsius. In some embodiments, the fluid can be heated to a temperature in a range from 38 degrees Celsius to 42 degrees Celsius.

[0069] In contrast, instead of the fluid being introduced into a fluid sac, the fluid can be expelled from the irrigation port 181 and can directly contact tissue. The fluid 182 can be expelled from the irrigation port 181 such that the fluid 182 substantially covers the electrodes 171. For example, the fluid 182 can be expelled such that it reaches the distal most electrodes 171. In some embodiments, the irrigation port 181 can have a greater width than a height, forming a planar irrigation port configured to expel a flow (e.g., fan shaped flow) of fluid 182 over the electrodes 171 disposed on the flexible framework, as depicted.

[0070] FIG. 5B is a top view of a fifth embodiment of the thermal mapping catheter 170' with a second number of electrodes. The thermal mapping catheter 170' can include longitudinally extending arms 172', 173', 174', 175', 176', 177', which can form the flexible framework on which ring electrodes 171' are carried. In some embodiments, the flexible framework can include 32 electrodes 171'. Although 32 electrodes are depicted, greater than or fewer than 32 electrodes can be disposed on the flexible framework. The thermal mapping catheter 170' can also include the catheter shaft 180' and the connector 178'. In some embodiments, the catheter shaft 180' can include ring electrodes 179'.

[0071] The thermal mapping catheter can include an irrigation port 181', as discussed in relation to FIG. 5A, which can be configured to expel fluid 182' over the electrodes 171' disposed on the flexible framework, as depicted. The fluid 181' can warm tissue that is located adjacent to the electrodes 171', which can help unmask the Brugada pattern, as discussed herein. For example, the tissue can be warmed via the fluid 181' to a temperature in a range from 38 degrees Celsius to 42 degrees Celsius, which can cause the tissue to exhibit an ECG pattern recognizable as the Brugada pattern. However, in some embodiments, the tissue can be warmed to a temperature greater than 42 degrees Celsius. For example, in some embodiments, the tissue can be heated to a temperature in a range from 38 degrees Celsius to 45

degrees Celsius, 38 degrees Celsius to 50 degrees Celsius, 42 degrees Celsius to 48 degrees Celsius, and/or 42 degrees Celsius to 50 degrees Celsius.

**[0072]** FIG. 5C is an isometric front, side and top view of the fifth embodiment of the thermal mapping catheter 170 shown in FIG. 5A, according to various embodiments of the present disclosure. FIG. 5C further depicts the irrigation port 181, discussed in relation to FIGS. 5A and 5B, which is configured to direct fluid over the flexible framework. FIG. 5D is a side view of an irrigation assembly 185 shown in FIGS. 5A to 5C, according to various embodiments of the present disclosure. The irrigation assembly 185 can include a first irrigation lumen 184-1 and second irrigation lumen 184-2, which feed fluid 182 to a first irrigation port 181-1 and a second irrigation port 181-2. The irrigation ports can expel the fluid 182 over each side of the flexible support structure (e.g., flexible framework, planar array), shown in FIG. 5A. In some embodiments, the irrigation lumens 184-1, 184-2 can be made from a flexible, rigid, and/or semi-rigid material. For example, in some embodiments the irrigation lumens 184-1, 184-2 can be formed from plastic or metal. In some embodiments, and as depicted, the irrigation ports 181-1, 181-2 can be planar in shape (i.e., can have a greater width than a height), thus creating a generally planar fluid flow over the flexible framework. In some embodiments, a plane defined by each of the irrigation ports 181-1, 181-2 (e.g., distal opening of the irrigation ports 181-1, 181-2) can be parallel with a plane defined by the flexible support structure (e.g., planar array). This can enable the fluid 182 to be broadcast evenly over the planar array and the electrodes disposed thereon.

**[0073]** The irrigation assembly 185 can include the connector 178, which can include sockets 183-1, 183-2 in which the longitudinally extending arms can be inserted and secured. A third socket can be disposed on a diametrically opposed side to a first socket 183-1, and is hidden from view. In some embodiments, the connector 178 can include a connection socket 186, through which a pin can be inserted to secure the connector to the distal end of the catheter shaft 180.

**[0074]** In some embodiments, the fluid 182' can be expelled from the irrigation port 181' such that the fluid 182' substantially covers the electrodes 171. The heated fluid can cause the cardiac tissue to display the signs that are indicative of BrS. In some embodiments, the electrodes 171 can be used for mapping and/or ablation. For example, the electrodes can be used to monitor mapping signals produced by the tissue. In some embodiments, the mapping signals can exhibit an electrical pattern that can be associated with Brugada syndrome. In some embodiments, the electrodes can monitor mapping signals produced by the tissue while the fluid 182' is being expelled from the irrigation port 181', during a portion of the time while the fluid 182' is being expelled from the irrigation port 181', and/or before or after the fluid 182' has been expelled from the irrigation port 181'.

**[0075]** FIG. 6A is a top view of a sixth embodiment of a thermal mapping catheter 190 with a first number of electrodes. The thermal mapping catheter 190 can include longitudinally extending arms 192, 193, 194, 195, 196, 197, which can form the flexible framework on which ring electrodes 191 are carried. In some embodiments, the flexible framework can include 64 electrodes 191, although fewer than or greater than 64 electrodes can be disposed on the flexible framework. The thermal mapping catheter 190

can also include the catheter shaft 198 and the connector 199. In some embodiments, the catheter shaft 198 can include one or more ring electrodes 200.

**[0076]** In some embodiments, the electrodes 191 can deliver RF energy 201 at a decreased level as that associated with performing ablation to heat the cardiac tissue. In some embodiments, one or more temperature sensors can be disposed on the flexible framework and can enable the electrodes 191 to heat the cardiac tissue to a temperature range as discussed herein for the diagnosis of BrS. In an example, the temperature sensors can be disposed in one or more of the electrodes 191. In some embodiments, the electrodes 191 can be in communication (e.g., electrically coupled) with an energy source (e.g., radiofrequency (RF) generator), which can be configured to deliver energy (e.g., RF energy) to tissue (e.g., cardiac tissue) via one or more of the electrodes 191, which can cause the tissue to be heated. Some embodiments of the present disclosure can be configured to deliver unipolar RF energy to tissue via the electrodes 191. For example, unipolar RF energy can be delivered to one or more of the electrodes 191 and the RF energy can travel through the tissue to a patch, usually located on a back of the patient, in order to heat the tissue and/or electrodes 191.

**[0077]** FIG. 6B is a top view of a sixth embodiment of the thermal mapping catheter 190' with a second number of electrodes. The thermal mapping catheter 190' can include longitudinally extending arms 192', 193', 194', 195', 196', 197', which can form the flexible framework on which ring electrodes 191' are carried. In some embodiments, the flexible framework can include 32 electrodes 191'. The thermal mapping catheter 190' can also include the catheter shaft 198' and the connector 199'. In some embodiments, the catheter shaft 198' can include ring electrodes 200'. As discussed in relation to FIG. 6A, the electrodes 191 can deliver RF energy at a decreased level as that associated with performing ablation to heat the cardiac tissue and can be controlled based on feedback received from one or more temperature sensors disposed on the flexible framework.

**[0078]** In some embodiments, the electrodes (e.g., electrodes 201, 201') associated with the embodiments depicted in FIGS. 6A and 6B can be heated to a particular temperature and/or for a particular time. The electrodes can be disposed against a tissue (e.g., cardiac tissue) to cause the tissue to be heated in order to unmask the Brugada pattern. In some embodiments, the electrodes can be heated to a temperature in a range from 50 degrees Celsius to 60 degrees Celsius. However, the electrodes can be heated to a temperature less than 50 degrees Celsius and/or greater than 60 degrees Celsius. For example, the electrodes can be heated to a temperature in a range of 35 degrees Celsius to 65 degrees Celsius. In some embodiments, the electrodes can be heated to a temperature in a range from 38 degrees Celsius to 42 degrees Celsius.

**[0079]** In some embodiments, the electrodes can be heated to warm an adjacent tissue and then turned off to perform a mapping function. In some embodiments, the tissue can be warmed via the electrodes to a temperature in a range from 38 degrees Celsius to 42 degrees Celsius, which can cause the tissue to exhibit an ECG pattern recognizable as the Brugada pattern. However, in some embodiments, the tissue can be warmed to a temperature greater than 42 degrees Celsius. For example, in some embodiments, the tissue can be heated to a temperature in a range from 38 degrees

Celsius to 45 degrees Celsius, 38 degrees Celsius to 50 degrees Celsius, 42 degrees Celsius to 48 degrees Celsius, and/or 42 degrees Celsius to 50 degrees Celsius.

[0080] FIG. 7 depicts a combination thermal mapping and ablation catheter 206, according to various embodiments of the present disclosure. In some embodiments, the thermal mapping and ablation catheter 206 can include longitudinally extending arms 210, 212, 214, 216, 218, 220, which can form a flexible framework (e.g., planar array) on which a number of electrodes can be disposed. In some embodiments, the thermal mapping and ablation catheter can include greater than or less than six longitudinally extending arms. In an example, the number of electrodes can include a number of heating electrodes, that include negative heating electrodes 230-1, 230-2, 230-*n* (hereinafter generally referred to as negative heating electrodes 230), designated by a negative symbol in FIG. 7, and a number of positive heating electrodes 232-1, 232-2, 232-*n* (hereinafter generally referred to as positive heating electrodes 232), designated by a positive symbol in FIG. 7. In some embodiments, the negative heating electrodes 230 and positive heating electrodes 232 can be disposed on alternating longitudinally extending arms. For example, as depicted, negative heating electrodes 230 can be disposed on a first outboard arm 210; positive heating electrodes 232 can be disposed on a first medial arm 212; negative heating electrodes 230 can be disposed on a first inboard arm 214; positive heating electrodes 232 can be disposed on a second inboard arm 216; negative heating electrodes 230 can be disposed on a second medial arm 218; and positive heating electrodes 232 can be disposed on a second outboard arm 220.

[0081] In some embodiments, the negative heating electrodes 230 and the positive heating electrodes 232 can be in communication with an energy source (e.g., radiofrequency (RF) generator), which can be configured to deliver energy (e.g., RF energy) to tissue (e.g., cardiac tissue) via one or more of the electrodes 230, 232, which can cause the tissue to be heated. Some embodiments of the present disclosure can be configured to deliver multipolar (e.g., bipolar) RF energy to tissue via the electrodes 230, 232. For example, bipolar RF energy can be delivered to one or more of the positive heating electrodes 232 and the RF energy can travel through the tissue to one or more of the negative heating electrodes 230 in order to heat the tissue and/or electrodes 230, 232.

[0082] In some embodiments, mapping electrodes 228, designated as 'M' in FIG. 7, can be disposed on one or more of the longitudinally extending arms 210, 212, 214, 216, 218, 220. In an example, and as depicted, the mapping electrodes 228 can be disposed on each of the longitudinally extending arms 210, 212, 214, 216, 218, 220. In some embodiments, the heating electrodes and the mapping electrodes 228 can be disposed on each of the longitudinally extending arms 210, 212, 214, 216, 218, 220 in a longitudinally alternating pattern. For example, each of the heating electrodes can be separated from an adjacent heating electrode disposed on one of the arms via a mapping electrode, as depicted in FIG. 7. For example, with reference to the first outboard arm 210, the negative heating electrodes 230 can be separated by the mapping electrodes 228. With reference to the first medial arm 212, the positive heating electrodes 232-1 can be separated by the mapping electrodes 228. In some embodiments, the positive heating electrodes 232 and the negative heating electrodes 230 can be disposed on each

of the longitudinally extending arms 210, 212, 214, 216, 218, 220 in a transversely alternating pattern. For example, each of the heating electrodes can be separated from an adjacent heating electrode disposed on an adjacent arm via a mapping electrode 228, as depicted in FIG. 7. In some embodiments, half of the electrodes can be mapping electrodes 228 and half of the electrodes can be heating electrodes.

[0083] In some embodiments, one or more thermocouples can be disposed along one or more of the longitudinally extending arms 210, 212, 214, 216, 218, 220. As depicted, thermocouples 226-1, 226-2, 226-3, 226-4 can be located in proximal and distal quadrants of the flexible framework of the thermal mapping and ablation catheter 206. For example, the thermocouples 226-1, 226-2, 226-3, 226-4 can be disposed on a proximal and distal portion of each of the first outboard arm 210 and the second outboard arm 220. However, thermocouples can be disposed along other portions of the first outboard arm 210 and the second outboard arm 220, as well as along other portions of the longitudinally extending arms forming the flexible framework. In some embodiments, the thermocouples can be disposed on or adjacent to heating electrodes. For example, thermocouples 226-1, 226-2 can be disposed on negative heating electrodes and thermocouples 226-3, 226-4 can be disposed on positive heating electrodes.

[0084] In some embodiments, the heating electrodes (e.g., negative electrodes 230 and positive electrodes 232) can be warmed to a temperature that is configured to unmask the Brugada pattern (e.g., a pattern recognizable in an ECG). In an example, the electrodes can be heated to a temperature in a range previously disclosed herein. The temperature can be defined by a user, in some embodiments, and/or may be pre-programmed into computer executable instructions. In some embodiments, the heating electrodes can be heated to a temperature in a range of 50 degrees Celsius to 60 degrees Celsius. However, the heating electrodes can be heated to a temperature less than 50 degrees Celsius and/or greater than 60 degrees Celsius. For example, the heating electrodes can be heated to a temperature in a range of 35 degrees Celsius to 65 degrees Celsius. In some embodiments, the heating electrodes can be heated to a temperature in a range from 38 degrees Celsius to 42 degrees Celsius. In some embodiments, the tissue can be warmed via the electrodes to a temperature in a range from 38 degrees Celsius to 42 degrees Celsius, which can cause the tissue to exhibit an ECG pattern recognizable as the Brugada pattern. However, in some embodiments, the tissue can be warmed to a temperature greater than 42 degrees Celsius. For example, in some embodiments, the tissue can be heated to a temperature in a range from 38 degrees Celsius to 45 degrees Celsius, 38 degrees Celsius to 50 degrees Celsius, 42 degrees Celsius to 48 degrees Celsius, and/or 42 degrees Celsius to 50 degrees Celsius.

[0085] In some embodiments, the thermocouples 228 can provide feedback regarding a temperature to which the electrodes have been heated and/or to which tissue being heated by the electrodes has been heated. The feedback can be analyzed to control an amount of RF energy provided to the electrodes in order to vary their temperature based on the feedback. At a same time that the heating electrodes are heated, before the heating electrodes are heated, and/or after the heating electrodes are heated, the mapping electrodes 228 can collect ECG data from the tissue. In some embodi-

ments, the mapping electrodes **228** can collect ECG data from the tissue that has been warmed (e.g., tissue located in a pericardial region of the heart). The ECG data can be analyzed to determine whether the ECG data exhibits the Brugada pattern.

**[0086]** In some embodiments, the heating electrodes can be heated to a particular temperature for a particular period of time. In an example, the heating electrodes can be heated to an upper limit temperature for a particular period of time and then to a lower limit temperature for a particular period of time. Accordingly, the heating electrodes can heat tissue to a temperature between the upper limit temperature and the lower limit temperature. In some embodiments, the upper limit temperature can be a temperature associated with the performance of ablation. However, the heating electrodes can be heated to the upper limit temperature for a period of time that does not result in the tissue being heated to the temperature associated with the performance of ablation. In some embodiments, as the upper limit temperature is increased, the time period for which the heating electrode is heated to the upper limit temperature can be decreased and/or a time period for which the heating electrode is heated to the lower limit temperature can be increased. As such, even though the heating electrodes may be heated to a temperature associated with the performance of ablation, the tissue being heated by the heating electrodes may be heated to a lower temperature at which the tissue may exhibit a pattern that is associated with BrS (e.g., a temperature between the upper limit temperature and the lower limit temperature).

**[0087]** In some embodiments, one or more of the heating electrodes can receive an increased RF energy, which can cause the heating electrodes to be heated to a temperature sufficient to perform a therapeutic treatment (e.g., ablation). In some embodiments, the temperature sufficient to perform therapeutic treatment can be in a range from 42 degrees Celsius to 70 degrees Celsius, however the temperature can be greater than 70 degrees Celsius or less than 42 degrees Celsius. In some embodiments, the heating electrodes can be heated to a temperature in a range from 50 degrees Celsius to 70 degrees Celsius, 60 degrees Celsius to 70 degrees Celsius, and/or 65 degrees Celsius to 70 degrees Celsius to perform therapeutic treatment (e.g., a temperature between the upper limit temperature and the lower limit temperature). In some embodiments, the one or more of the heating electrodes can be selected to receive an increased RF energy in response to a Brugada pattern being recognized in the ECG data. Thus, the thermal mapping and ablation catheter **206** can be configured to controllably heat tissue (e.g., cardiac tissue) with the heating electrodes to cause the tissue to exhibit an ECG pattern recognizable as the Brugada pattern. The thermal mapping and ablation catheter **206** can be configured to detect the ECG pattern with the mapping electrodes **228**, in order to identify the Brugada pattern. Additionally, in some embodiments, the thermal mapping and ablation catheter **206** can heat a selected number of the heating electrodes to a temperature consistent with the performance of tissue ablation.

**[0088]** FIG. **8** depicts a flow diagram associated with a method **240** for thermal mapping and ablation, according to various embodiments of the present disclosure. The method **240** can be performed in relation to embodiments discussed herein, such as those discussed in FIGS. **6A** to **7**. In some embodiments, the method **240** can include causing a plural-

ity of heating electrodes disposed on a flexible framework to be heated to a first temperature lower than which radio frequency ablation is performed for a defined time, at block **242**. The defined time can be selectable by a user, in some embodiments. In an example, the electrodes can contact tissue (e.g., epicardial tissue) and the tissue can be heated to a temperature in a range, such as that previously discussed, to cause the tissue to be heated in order to unmask the Brugada pattern.

**[0089]** In some embodiments, at block **244**, the method **240** can include receiving a plurality of mapping signals from a plurality of mapping electrodes disposed on the flexible framework during the defined time. In some embodiments, the mapping signals from the plurality of mapping electrodes disposed on the flexible framework can be received during a portion of the defined time. The mapping signals can be electrical signals (e.g., ECG signals), which can be analyzed to determine whether any of the plurality of mapping signals exhibit a particular electrical pattern, at block **246**. In an example, a filter can be applied to the mapping signals to determine whether one or more of the mapping signals exhibit a pattern that is associated with BrS.

**[0090]** In some embodiments, the method **240** can include causing one or more of the plurality of heating electrodes disposed on the flexible framework to be heated to a second temperature at which radio frequency ablation is performed, based on the determination, at block **248**. In an example, the method **240** can include causing one or more of the plurality of heating electrodes to be heated to the temperature at which radio frequency ablation is performed in response to a determination that one or more of the mapping signals exhibit the particular electrical pattern. In some embodiments, upon recognition that one or more of the mapping signals exhibit the particular electrical pattern, an indication can be displayed to a user (e.g., via a user interface) and/or the heating electrodes can be heated to the temperature at which radio frequency ablation is performed automatically.

**[0091]** In some embodiments, the method **240** can include causing one or more of the plurality of heating electrodes disposed adjacent to one or more of the mapping electrodes from which a mapping signal exhibiting the particular pattern is received to be heated to the second temperature. Thus, tissue that exhibits the particular pattern (e.g., pattern associated with BrS) can be precisely targeted. For example, while the thermal mapping and ablation catheter **206**, depicted in FIG. **7** includes 32 mapping electrodes **228**, only some of the mapping electrodes **228** may contact tissue that exhibits an electrical pattern associated with BrS. Accordingly, heating electrodes surrounding those mapping electrodes **228** that have collected electrical signals exhibiting patterns associated with BrS can be heated to a temperature at which radio frequency ablation is performed. Thus, the tissue producing the electrical signals exhibiting patterns associated with BrS can be ablated via the electrodes surrounding the mapping electrodes **228**. As previously discussed and depicted in relation to FIG. **7**, one or more of the plurality of heating electrodes can be disposed at least one of longitudinally adjacent and transversely adjacent to one or more of the mapping electrodes, with respect to a longitudinal axis of the catheter and/or flexible framework on which the electrodes are disposed. In some embodiments, the method **240** can include causing one or more of the plurality of heating electrodes disposed on a particular

section of the flexible framework to be heated to a second temperature at which radio frequency ablation is performed. In an example, heating electrodes disposed on a proximal half, distal half, left side, right side, center, and/or combination thereof can be heated to the second temperature.

[0092] In some embodiments, after radio frequency ablation is performed, the method can be repeated, for example, to check whether the tissue still exhibits the pattern associated with BrS. For instance, the heating electrodes can be heated to the first temperature and the tissue can be mapped via the mapping electrodes to determine whether any of the plurality of mapping signals received from the mapping electrodes exhibit the pattern associated with BrS. Radio frequency ablation can be performed, as discussed herein, in response to one or more of the plurality of mapping signals exhibiting the pattern associated with BrS.

[0093] FIG. 9A depicts a diagram of a system 250 for thermal mapping and ablation, according to embodiments of the present disclosure. The system 250 can include a data store 252, a thermal mapping and/or ablation system 254, and/or a number of engines. The thermal mapping and/or ablation system 254 can be in communication with the data store 252. The thermal mapping and/or ablation system 254 can include a number of engines (e.g., heat engine 256, receive engine 258, determine engine 260, heat engine 262, etc.). The thermal mapping and/or ablation system 254 can include additional or fewer engines than illustrated to perform the various functions described herein. The number of engines can include a combination of hardware and programming to perform a number of functions described herein (e.g., receiving, determining, etc.). Each of the engines can include hardware or a combination of hardware and programming designated or designed to execute a module (e.g., a particular module). The programming can include instructions (e.g., software, firmware, etc.) stored in a memory resource (e.g., computer-readable medium) as well as a hard-wired program (e.g., logic).

[0094] The system 254 can include a computing device analogous to that discussed herein and with respect to FIG. 9B. In some embodiments, the computing device can include a digital display such as a graphical user interface (GUI), which is suitable for the display of electronic data. A user interface can include hardware components and/or computer-readable instruction components. For instance, hardware components can include input components (e.g., a mouse, a touchscreen, a keyboard, dials and buttons, etc.) and/or output components (e.g., a display, vibration generating devices, speakers, etc.). An example user interface can include a GUI, which can digitally represent data associated with thermal mapping and/or ablation.

[0095] The heat engine 256 can include hardware and/or a combination of hardware and programming to cause a plurality of heating electrodes disposed on a flexible framework to be heated to a first temperature lower than which radio frequency ablation is performed for a defined time. In some embodiments, a particular amount of RF energy can be generated and applied to one or more of the plurality of heating electrodes in order to cause the one or more heating electrodes to be heated. In some embodiments, a temperature sensor (e.g., thermocouple) can sense a particular temperature of one or more of the electrodes and/or tissue being heated by the one or more of the electrodes. In some embodiments, the temperature of the one or more of the temperature sensors can be provided as feedback to the

system 254 to adjust a particular amount of RF energy provided to the one or more heating electrodes.

[0096] The receive engine 258 can include hardware and/or a combination of hardware and programming to receive a plurality of mapping signals from a plurality of mapping electrodes disposed on the flexible framework during a portion of the defined time. In some embodiments, electrical signals produced by the cardiac tissue (e.g., epicardial tissue) can be mapped while the tissue is being heated to the first temperature (e.g., temperature lower than which radio frequency ablation is performed). In some embodiments, the plurality of mapping signals can be received during an entirety of the defined time or for a time that is less than the entirety of the defined time.

[0097] The determine engine 260 can include hardware and/or a combination of hardware and programming to determine whether any of the plurality of mapping signals exhibit a particular electrical pattern. In some embodiments, as discussed herein, a filter can be applied to the mapping signals to determine whether one or more of the plurality of mapping signals exhibit a particular electrical pattern associated with BrS.

[0098] The heat engine 262 can include hardware and/or a combination of hardware and programming to causing one or more of the plurality of heating electrodes disposed on the flexible framework to be heated to a second temperature at which radio frequency ablation is performed, based on the determination. In some embodiments, the plurality of heating electrodes can be heated to the second temperature for a second defined time period. In some embodiments, mapping signals can be received from the mapping electrodes while the heating electrodes are being heated to the second temperature and/or after the heating electrodes have been heated to the second temperature, to ensure that tissue responsible for producing the electrical pattern associated with BrS has been ablated.

[0099] FIG. 9B depicts a diagram of an example of a computing device 270 for thermal mapping and ablation according to the present disclosure. The computing device 270 can utilize software, hardware, firmware, and/or logic to perform a number of functions described herein.

[0100] The computing device 270 can be a combination of hardware and instructions to share information. The hardware, for example can include a processing resource 272 and/or a memory resource 276 (e.g., computer-readable medium (CRM), database, etc.). A processing resource 272, as used herein, can include a number of processors capable of executing instructions stored by the memory resource 276. Processing resource 272 can be integrated in a single device or distributed across multiple devices. The instructions (e.g., computer-readable instructions (CRI)) can include instructions stored on the memory resource 276 and executable by the processing resource 272 to implement a desired function (e.g., determine whether any of the plurality of mapping signals exhibit a particular electrical pattern, etc.).

[0101] The memory resource 276 can be in communication with the processing resource 272. The memory resource 276, as used herein, can include a number of memory components capable of storing instructions that can be executed by the processing resource 272. Such memory resource 276 can be a non-transitory CRM. Memory resource 276 can be integrated in a single device or distributed across multiple devices. Further, memory resource 276

can be fully or partially integrated in the same device as processing resource 272 or it can be separate but accessible to that device and processing resource 272. Thus, it is noted that the computing device 270 can be implemented on a support device and/or a collection of support devices, on a mobile device and/or a collection of mobile devices, and/or a combination of the support devices and the mobile devices.

**[0102]** The memory 276 can be in communication with the processing resource 272 via a communication link 274 (e.g., path). The communication link 274 can be local or remote to a computing device associated with the processing resource 272. Examples of a local communication link 274 can include an electronic bus internal to a computing device where the memory resource 276 is one of a volatile, non-volatile, fixed, and/or removable storage medium in communication with the processing resource 272 via the electronic bus.

**[0103]** Link 274 (e.g., local, wide area, regional, or global network) represents a cable, wireless, fiber optic, or remote connection via a telecommunication link, an infrared link, a radio frequency link, and/or other connectors or systems that provide electronic communication. That is, the link 274 can, for example, include a link to an intranet, the Internet, or a combination of both, among other communication interfaces. The link 274 can also include intermediate proxies, for example, an intermediate proxy server (not shown), routers, switches, load balancers, and the like.

**[0104]** The memory resource 276 can include a number of modules such as a heat module 278, a receive module 280, a determine module 282, and a heat module 284. The number of modules 278, 280, 282, 284 can include CRI that when executed by the processing resource 272 can perform a number of functions. The number of modules 278, 280, 282, 284 can be sub-modules of other modules. For example, the receive module 278 and the characterize module 280 can be sub-modules and/or contained within the same computing device. In another example, the number of modules 278, 280, 282, 284 can comprise individual modules at separate and distinct locations (e.g., CRM, etc.).

**[0105]** Each of the number of modules 278, 280, 282, 284 can include instructions that when executed by the processing resource 272 can function as a corresponding engine as described herein. For example, the determine module 282 can include CRI that when executed by the processing resource 272 can function as the determine engine 260. For instance, the determine module 282 can include CRI that when executed by the processing resource 232 can cause a computing device to determine whether any of the plurality of mapping signals exhibit a particular electrical pattern.

**[0106]** Embodiments are described herein of various apparatuses, systems, and/or methods. Numerous specific details are set forth to provide a thorough understanding of the overall structure, function, manufacture, and use of the embodiments as described in the specification and illustrated in the accompanying drawings. It will be understood by those skilled in the art, however, that the embodiments may be practiced without such specific details. In other instances, well-known operations, components, and elements have not been described in detail so as not to obscure the embodiments described in the specification. Those of ordinary skill in the art will understand that the embodiments described and illustrated herein are non-limiting examples, and thus it may be appreciated that the specific structural and functional details disclosed herein may be representative and do not

necessarily limit the scope of the embodiments, the scope of which is defined solely by the appended claims.

**[0107]** Reference throughout the specification to “various embodiments,” “some embodiments,” “one embodiment,” or “an embodiment”, or the like, means that a particular feature, structure, or characteristic described in connection with the embodiment(s) is included in at least one embodiment. Thus, appearances of the phrases “in various embodiments,” “in some embodiments,” “in one embodiment,” or “in an embodiment,” or the like, in places throughout the specification, are not necessarily all referring to the same embodiment. Furthermore, the particular features, structures, or characteristics may be combined in any suitable manner in one or more embodiments. Thus, the particular features, structures, or characteristics illustrated or described in connection with one embodiment may be combined, in whole or in part, with the features, structures, or characteristics of one or more other embodiments without limitation given that such combination is not illogical or non-functional.

**[0108]** It will be appreciated that the terms “proximal” and “distal” may be used throughout the specification with reference to a clinician manipulating one end of an instrument used to treat a patient. The term “proximal” refers to the portion of the instrument closest to the clinician and the term “distal” refers to the portion located furthest from the clinician. It will be further appreciated that for conciseness and clarity, spatial terms such as “vertical,” “horizontal,” “up,” and “down” may be used herein with respect to the illustrated embodiments. However, surgical instruments may be used in many orientations and positions, and these terms are not intended to be limiting and absolute.

**[0109]** Although at least one embodiment for thermal mapping catheter has been described above with a certain degree of particularity, those skilled in the art could make numerous alterations to the disclosed embodiments without departing from the spirit or scope of this disclosure. All directional references (e.g., upper, lower, upward, downward, left, right, leftward, rightward, top, bottom, above, below, vertical, horizontal, clockwise, and counterclockwise) are only used for identification purposes to aid the reader's understanding of the present disclosure, and do not create limitations, particularly as to the position, orientation, or use of the devices. Joinder references (e.g., affixed, attached, coupled, connected, and the like) are to be construed broadly and may include intermediate members between a connection of elements and relative movement between elements. As such, joinder references do not necessarily infer that two elements are directly connected and in fixed relationship to each other. It is intended that all matter contained in the above description or shown in the accompanying drawings shall be interpreted as illustrative only and not limiting. Changes in detail or structure may be made without departing from the spirit of the disclosure as defined in the appended claims.

**[0110]** Any patent, publication, or other disclosure material, in whole or in part, that is said to be incorporated by reference herein is incorporated herein only to the extent that the incorporated materials does not conflict with existing definitions, statements, or other disclosure material set forth in this disclosure. As such, and to the extent necessary, the disclosure as explicitly set forth herein supersedes any conflicting material incorporated herein by reference. Any material, or portion thereof, that is said to be incorporated by

reference herein, but which conflicts with existing definitions, statements, or other disclosure material set forth herein will only be incorporated to the extent that no conflict arises between that incorporated material and the existing disclosure material.

What is claimed:

1. A catheter, comprising:
  - a catheter shaft comprising a proximal end and a distal end; and
  - a flexible framework connected to the distal end of the catheter shaft, wherein the flexible framework includes a plurality of heating electrodes and a temperature sensor, wherein:
    - the plurality of heating electrodes are configured to be heated to a first temperature, the first temperature being lower than which radio frequency ablation is performed; and
    - the plurality of heating electrodes are configured to be heated to a second temperature, the second temperature being a temperature at which radio frequency ablation is performed.
2. The catheter of claim 1, wherein the flexible framework includes a plurality of mapping electrodes configured to collect electrical signals from tissue being heated by the plurality of heating electrodes.
3. The catheter of claim 2, wherein the plurality of mapping electrodes are configured to collect the electrical signals from the tissue while the plurality of heating electrodes are being heated to the first temperature.
4. The catheter of claim 3, wherein the flexible framework includes a plurality of longitudinally-extending arms on which the plurality of electrodes are disposed.
5. The catheter of claim 4, wherein the mapping electrodes and the heating electrodes are disposed on each of the plurality of longitudinally-extending arms in a longitudinally alternating pattern.
6. The catheter of claim 1, wherein the first temperature is in a range of 35 to 65 degrees Celsius and the second temperature is in a range of 42 to 70 degrees Celsius.
7. The catheter of claim 1, wherein the flexible framework comprises a planar array.
8. The catheter of claim 1, further comprising an energy source in communication with the heating electrodes.
9. The catheter of claim 8, wherein the energy source is a radiofrequency (RF) generator configured to deliver unipolar RF energy to tissue via the electrodes.
10. The catheter of claim 8, wherein:
  - the energy source is an RF generator configured to deliver bipolar RF energy to tissue via the electrodes; and
  - the electrodes include positive heating electrodes and negative heating electrodes.
11. A catheter, comprising:
  - a catheter shaft comprising a proximal end and a distal end;
  - a flexible framework connected to the distal end of the catheter shaft, wherein the flexible framework includes a plurality of electrodes disposed thereon; and
  - a fluid sac connected to the flexible framework, wherein the fluid sac includes a heater and is configured to be filled with a fluid.
12. The catheter of claim 11, wherein the fluid sac is one of a plurality of fluid sacs connected to the flexible framework.

13. The catheter of claim 12, wherein the catheter is configured to circulate fluid between two or more of the plurality of fluid sacs.

14. The catheter of claim 12, wherein each of the plurality of fluid sacs includes a temperature sensor.

15. The catheter of claim 11, wherein:

the flexible framework includes a plurality of longitudinally-extending arms on which the plurality of electrodes are disposed, the plurality of longitudinally-extending arms extending from the distal end of the catheter shaft;

the fluid sac is one of a plurality of fluid sacs; and

the plurality of fluid sacs are disposed between at least a pair of the longitudinally-extending arms.

16. The catheter of claim 15, further comprising a heater disposed in each of the plurality of fluid sacs, wherein the heaters are configured to heat the fluid in each of the plurality of fluid sacs to a temperature in a range of 35 degrees Celsius to 65 degrees Celsius.

17. The catheter of claim 16, wherein the heaters are formed from at least one of a conductive wire, a flexible circuit, and a thin film.

18. The catheter of claim 11, wherein the flexible framework comprises a planar array.

19. A method for thermal mapping and ablation, comprising:

causing a plurality of heating electrodes disposed on a flexible framework to be heated to a first temperature lower than which radio frequency ablation is performed for a defined time;

receiving a plurality of mapping signals from a plurality of mapping electrodes disposed on the flexible framework during the defined time;

determining whether any of the plurality of mapping signals exhibit a particular electrical pattern; and

causing one or more of the plurality of heating electrodes disposed on the flexible framework to be heated to a second temperature at which radio frequency ablation is performed, based on the determination.

20. The method of claim 19, further comprising causing one or more of the plurality of heating electrodes to be heated to the second temperature in response to a determination that one or more of the mapping signals exhibit the particular electrical pattern.

21. The method of claim 19, further comprising causing one or more of the plurality of heating electrodes disposed adjacent to one or more of the mapping electrodes from which a mapping signal exhibiting the particular pattern is received to be heated to the second temperature.

22. The method of claim 21, wherein the one or more of the plurality of heating electrodes are disposed at least one of longitudinally adjacent and transversely adjacent to one or more of the mapping electrodes.

23. The method of claim 21, further comprising causing one or more of the plurality of heating electrodes disposed on a particular section of the flexible framework to be heated to the second temperature.

24. The method of claim 19, wherein determining whether any of the plurality of mapping signals exhibit a particular electrical pattern includes applying a filter to one or more of the plurality of mapping signals.

25. The method of claim 19, wherein the method further includes heating cardiac tissue to a temperature lower than



which radio frequency ablation is performed with the plurality of heating electrodes disposed on the flexible framework.

**26.** The method of claim **19**, wherein the particular electrical pattern is associated with Brugada syndrome.

**27.** A catheter, comprising:

a catheter shaft comprising a proximal end and a distal end;

a flexible framework connected to the distal end of the catheter shaft, wherein the flexible framework includes a plurality of electrodes disposed thereon; and

an irrigation channel extending through the catheter shaft and an irrigation port disposed at the distal end of the catheter shaft and in fluid communication with the irrigation channel, wherein the catheter is configured to:

expel heated fluid from the irrigation port; and

monitor mapping signals produced by a tissue via the plurality of electrodes disposed on the flexible framework.

**28.** The catheter of claim **27**, wherein the flexible framework comprises a planar array.

**29.** The catheter of claim **28**, wherein a shape of the irrigation port is planar.

**30.** The catheter of claim **29**, wherein a plane defined by a distal opening of the irrigation port is parallel with a plane defined by the planar array.

**31.** The catheter of claim **27**, wherein the heated fluid is heated to a temperature in a range from 38 degrees to 42 degrees Celsius.

\* \* \* \* \*