

(19)
(12)

(KR)
(B1)

(51) 。 Int. Cl. ⁶
A47C 27/00

(45)
(11)
(24)

2001 11 30
10 - 0308612
2001 08 30

(21) 10 - 1998 - 0029346
(22) 1998 07 15

(65) 1999 - 0014037
(43) 1999 02 25

(73) 49

(72) 1484

(74)
:

(54)

가

, ,
.

1

1

2 1 -

3a 3b

3a ,

3b 3 - ,

4

5 4 -

6 가

7 8

7

8

< >

10 : 20 :

21 : 22 :

30 : 40 :

41 : 41a :

41b : 42 :

43 : 44 :

50 : 60 :

70 :

가 가

5.6 ~ 1,000 μm
(生育光線)

8 ~ 20 μm

가

가

97 - 5718

가

가

가

가

가

1 , 2 1 - 3a 3b

5 4 - 4

(20) 가 (40) , (20) , (10) , (20) (30) , (20) (20) (30) (40) (50)

(20) (20') (21) (絹雲母) (21)

(單斜晶系)

'sericite'

(熱水作用)

가 (堇青石) (紅柱石) 2 (陶石) K , 가 H₂O가 (70 %) (30) (滑摩材)

%)

가 가 가 가

성분	SiO ₂	Al ₂ O ₃	Fe ₂ O ₃	CaO	MgO	Na ₂ O	K ₂ O
중량	67.1%	17.2%	1.59%	0.32%	0.12%	4.30%	4.71%

5~20 μm (W/m² · μm · 40) 3.74 × 10⁻²)

7 8 FT - IR (spectrometer) (black bo
 dy) 8 a , b
 (21) (20') (21)
 (21) (22) (20)
 (20') (21) (20)
 (21) 가 , , , , ,
 (40) (20) (21) 가 (21)
 (10)
 (21) 40
 (40)

(40) (41) 가 , (41) (42)
 (41) 가 가 (box)
 (41b)가 (41b) (41a)가 (42) (41a)

(41) (41b) (42) (21)
 (21) (3b)

(42) 가 (42) (43) (43)

(40)

(40) (20) (40)
 (60) 가

(40) (41) (44) (42)
 (40) (21) (20) (21)

(10) (50)

(70)

(1)

(30) (20') (30) (20') (20') (20') (21)

(20')

(20') (20')

(20')

6:4 가 (21) , (21) 2~3 (3
 ~4mm)

, .
 (BFT) ; 70 (%) [(50 (%) + 20 (%)]
 ; 5 (%)
 ; 10 (%)
 ; 5 (%)
 ; 5 (%)
 ; 5 (%)

(20')

3~4mm

2~3

(,), , , ,

, , , , ,

(21) (20') ,
 (21) (20)

(20) (21) (22)
 (21) (21) (20)

(21) (20) 2~3 가
 (20) (21) (21) 가 ,

(20) (21) 가 .

6 (20)가 , (20)

(20) ,
 (20)가 가 .

가

(57)

1.

가

2.

1

3.

1 2
가

4.

1

5.

1 4

6.

1

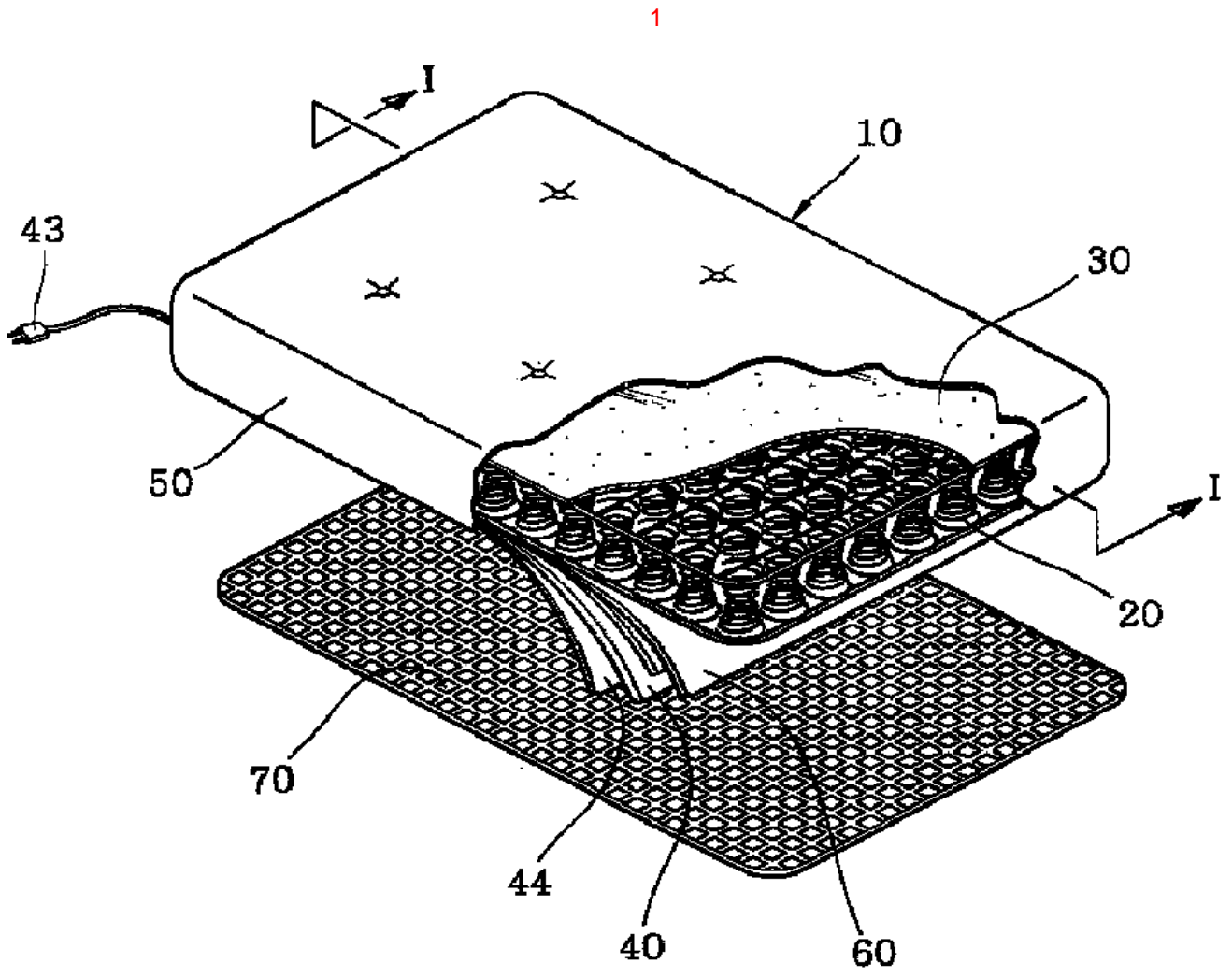

2

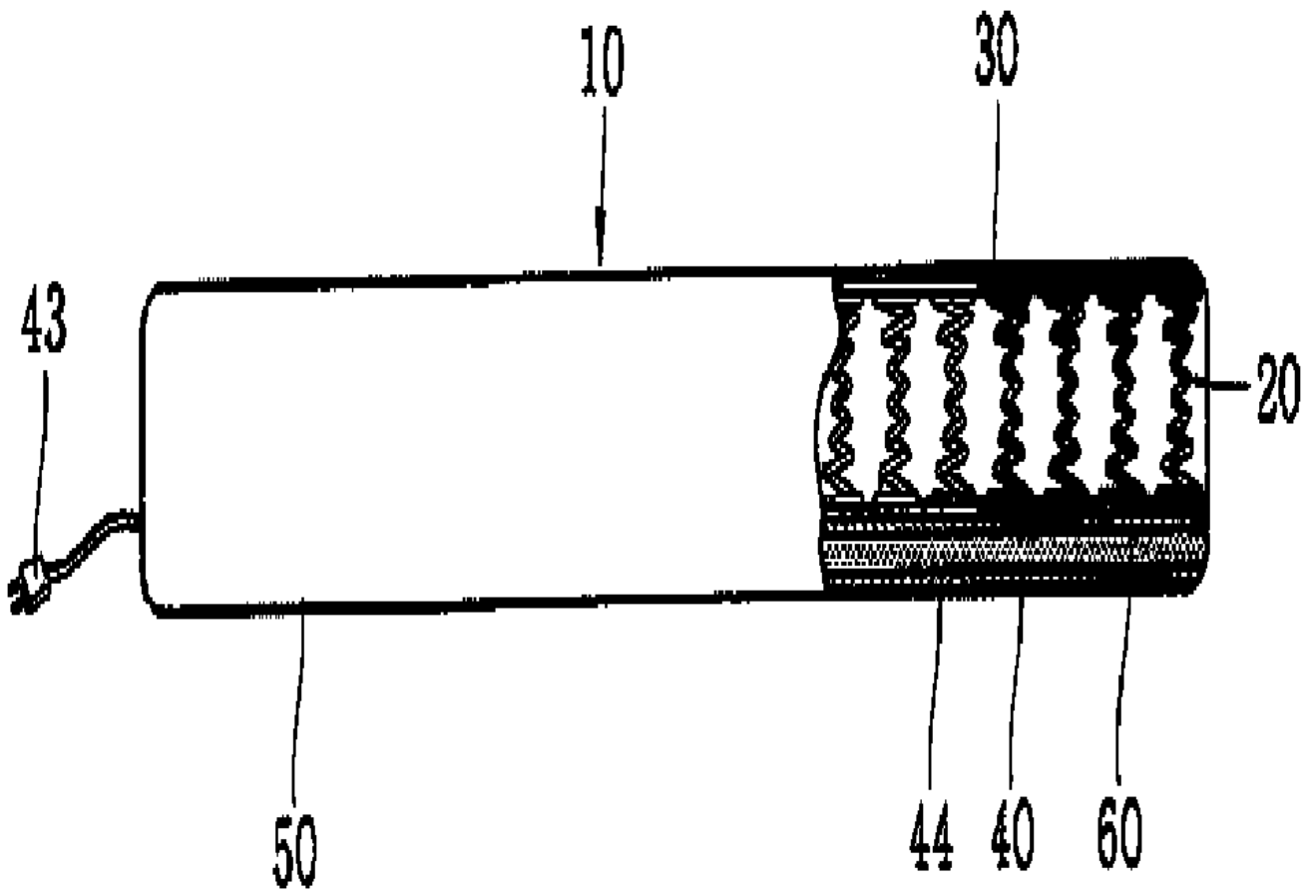

3a

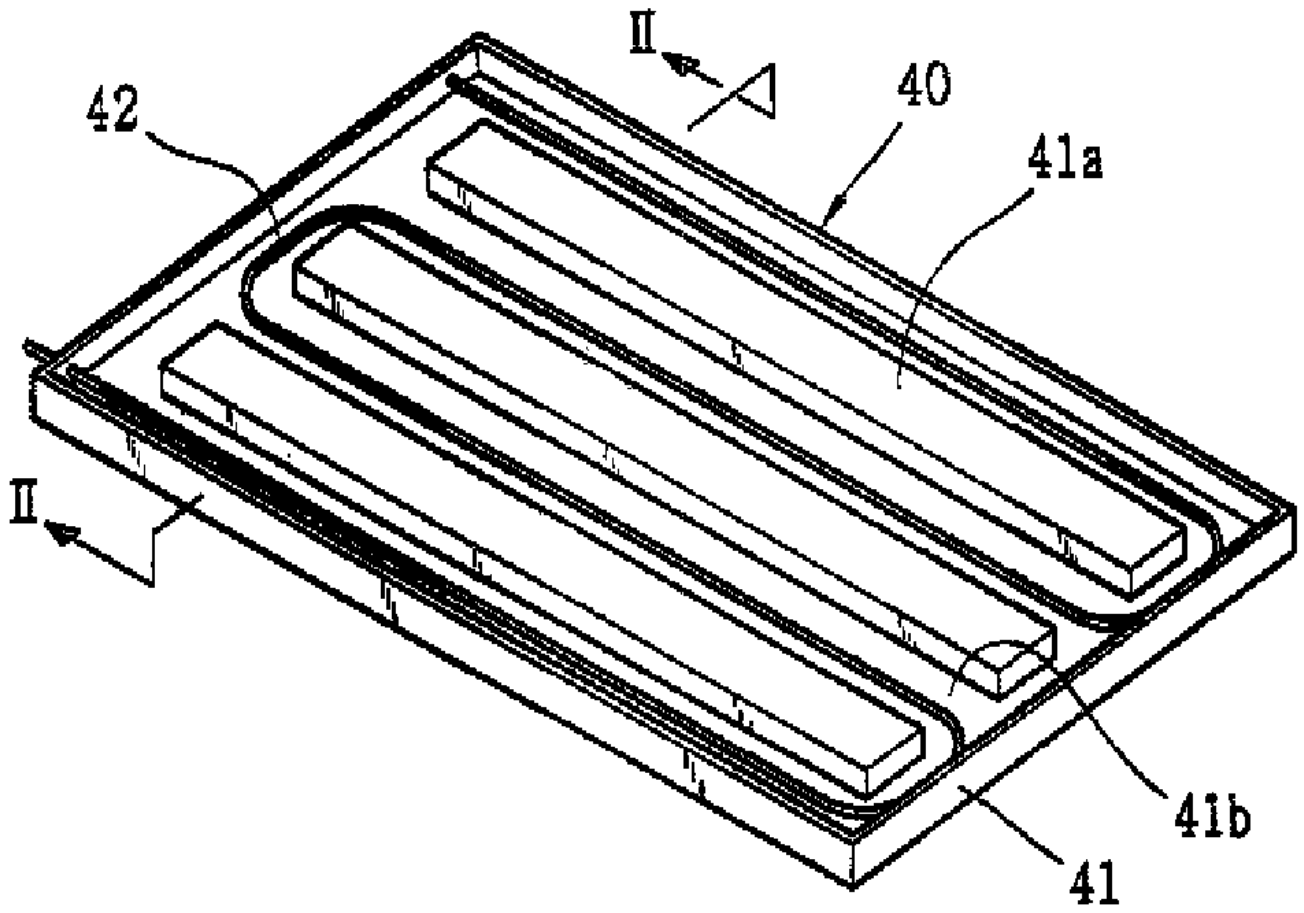

3b

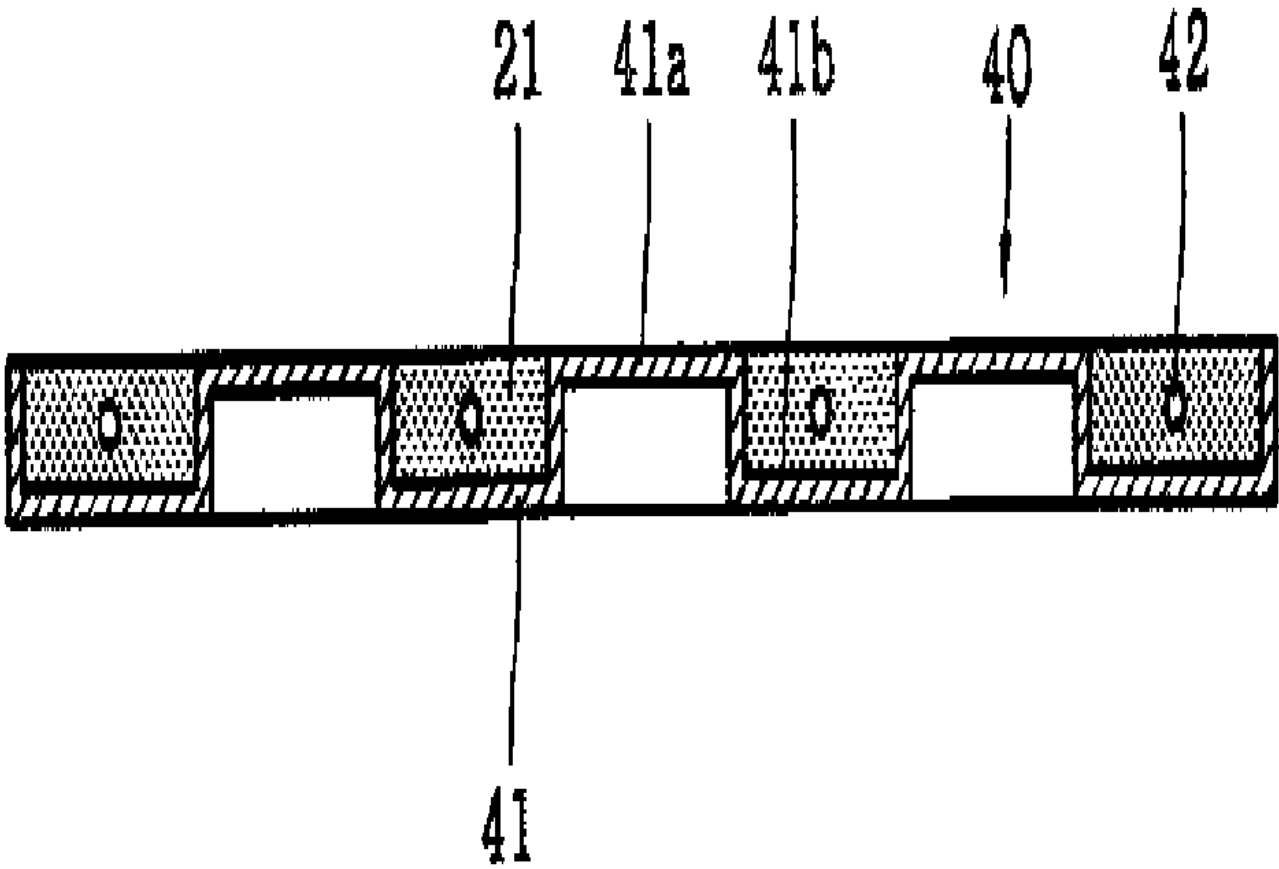

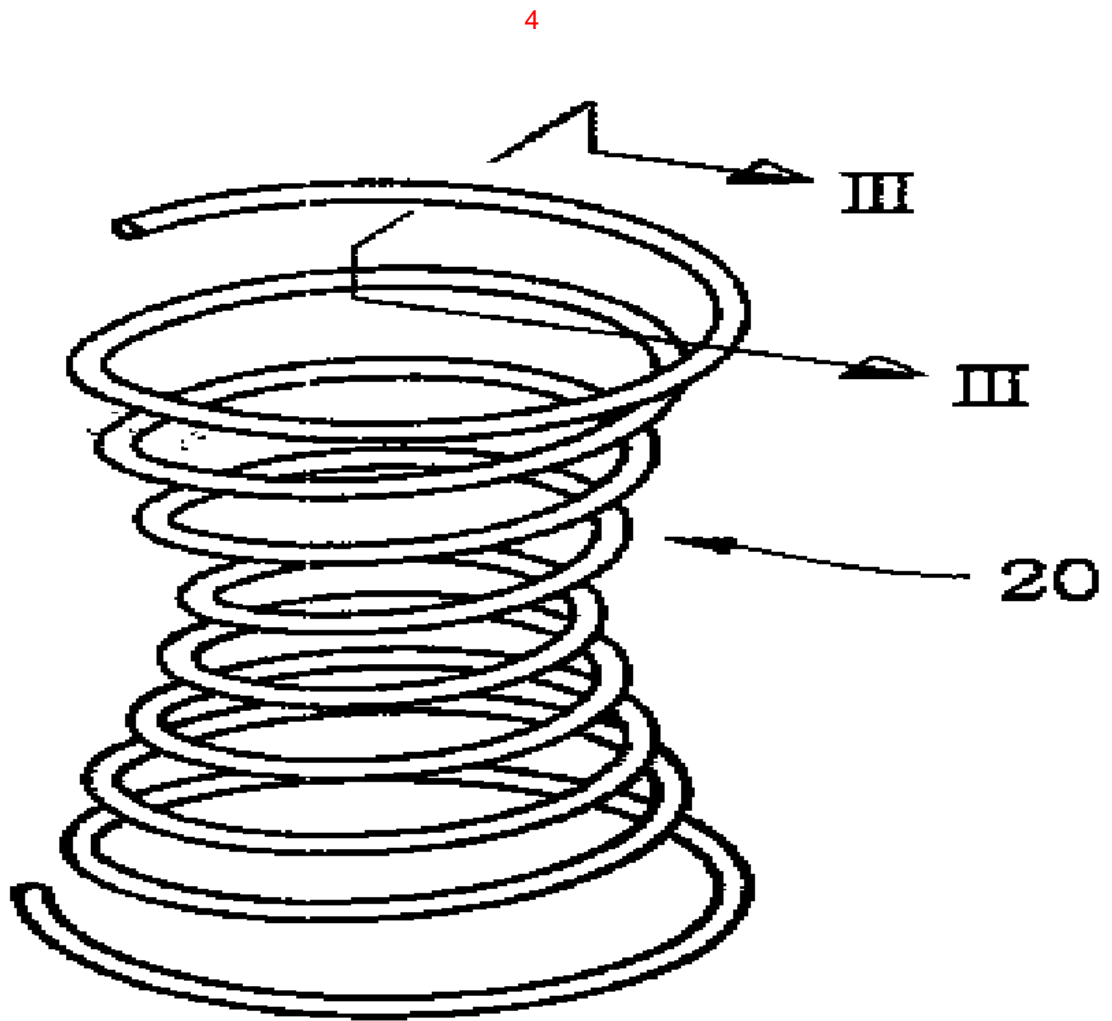

5

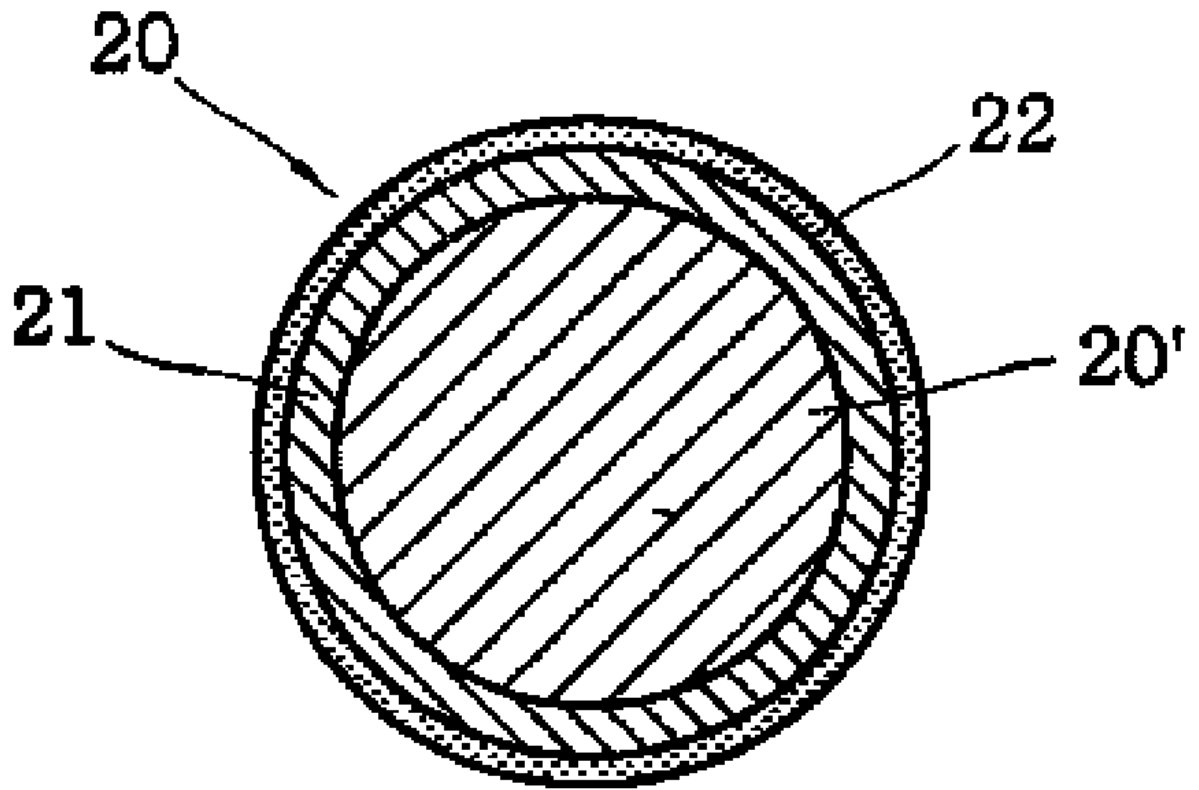

6

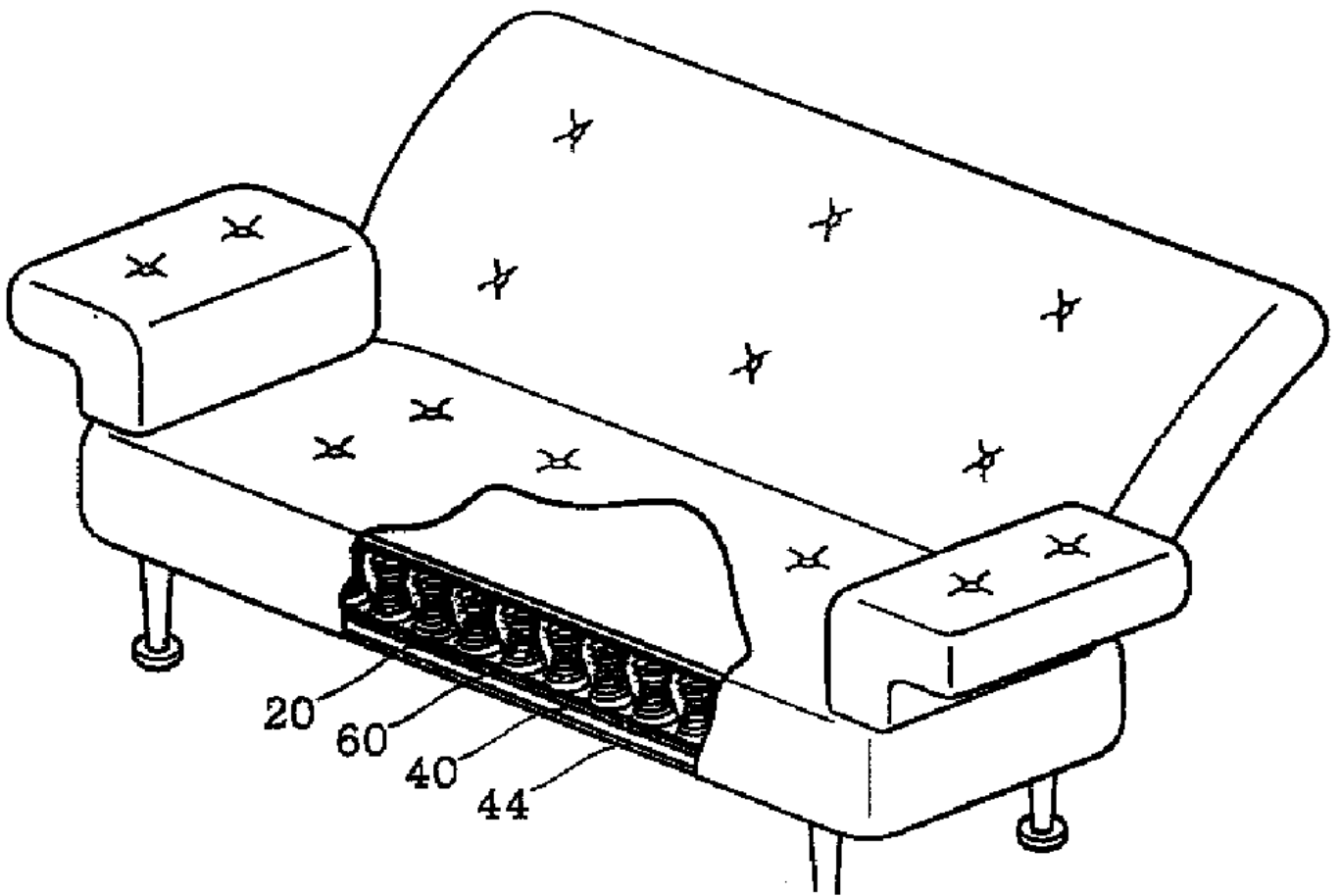

7

