



(19) **United States**

(12) **Patent Application Publication**

**Koeck et al.**

(10) **Pub. No.: US 2021/0405081 A1**

(43) **Pub. Date: Dec. 30, 2021**

(54) **ANGLE BASED SPEED SENSOR DEVICE**

**Publication Classification**

(71) Applicant: **Infineon Technologies AG**, Neubiberg (DE)

(51) **Int. Cl.**

- G01P 3/487* (2006.01)
- G01C 21/10* (2006.01)
- G01C 25/00* (2006.01)
- G01L 3/10* (2006.01)
- G01D 5/244* (2006.01)
- G01D 5/246* (2006.01)
- G01D 5/245* (2006.01)
- G01D 5/14* (2006.01)

(72) Inventors: **Helmut Koeck**, Villach (AT); **Leo Aichriedler**, Puch (AT); **Dirk Hammerschmidt**, Finkenstein (AT); **Andrea Monterastelli**, Villach (AT); **Friedrich Rasbornig**, Klagenfurt (AT); **Peter Slama**, Klagenfurt (AT); **Dietmar Spitzer**, Voelkermarkt (AT); **Tobias Werth**, Villach (AT); **Harald Witschnig**, Landskron (AT)

(52) **U.S. Cl.**

- CPC ..... *G01P 3/487* (2013.01); *G01C 21/10* (2013.01); *G01C 25/005* (2013.01); *G01D 5/145* (2013.01); *G01D 5/244* (2013.01); *G01D 5/246* (2013.01); *G01D 5/2454* (2013.01); *G01L 3/101* (2013.01)

(21) Appl. No.: **17/468,863**

(22) Filed: **Sep. 8, 2021**

**Related U.S. Application Data**

(63) Continuation of application No. 15/655,443, filed on Jul. 20, 2017, now Pat. No. 11,125,768, which is a continuation-in-part of application No. 14/306,442, filed on Jun. 17, 2014, now Pat. No. 10,222,234.

(57)

**ABSTRACT**

A sensor device is provided with a magnetic field sensitive element being positioned in a magnetic field of a magnet. The magnetic field sensitive element is configured to sense an orientation angle of the magnetic field in the range between 0° and 360° and generate a sensing signal. The electronic circuitry is configured to receive and process the sensing signal from the magnetic field sensitive element to generate an angle signal indicating the orientation angle of the magnetic field and an angular speed of the shaft.

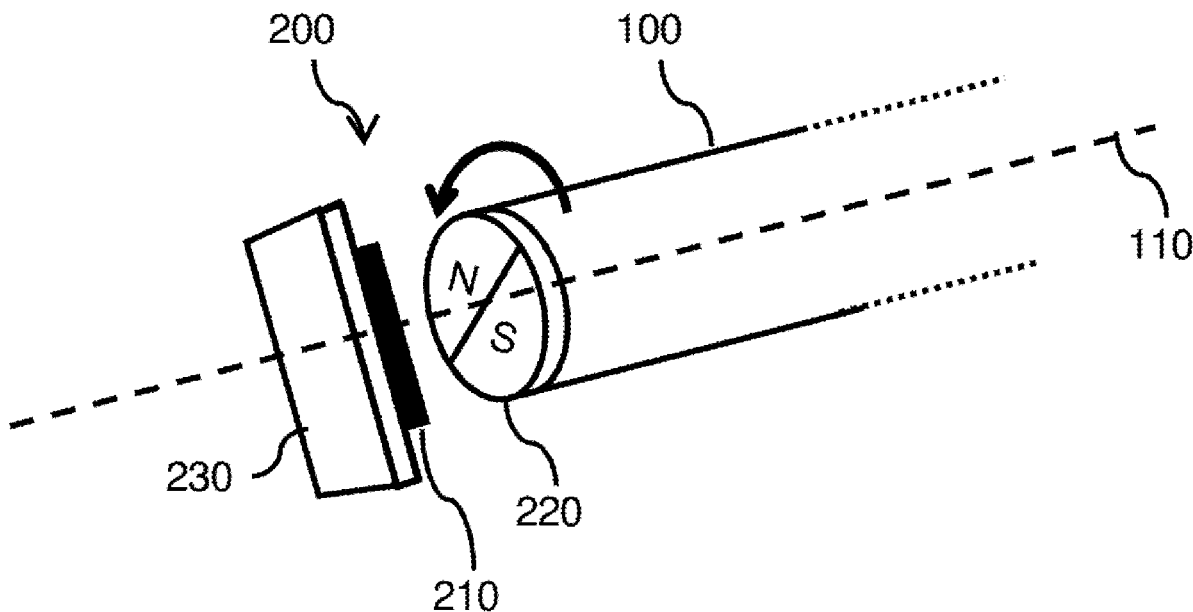

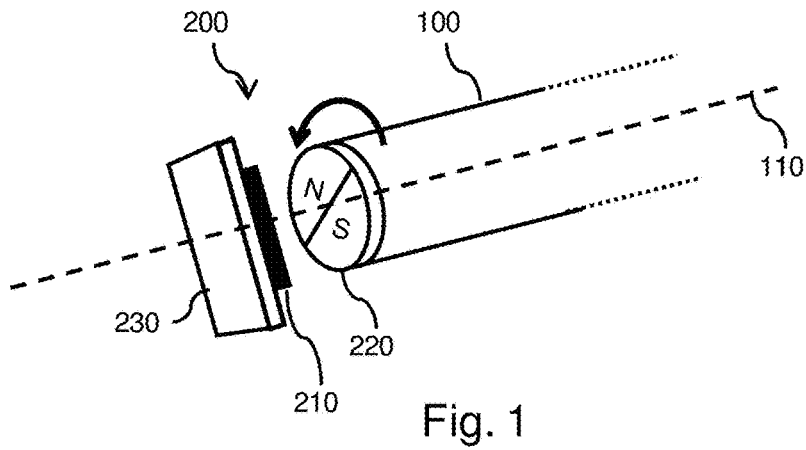

Fig. 1

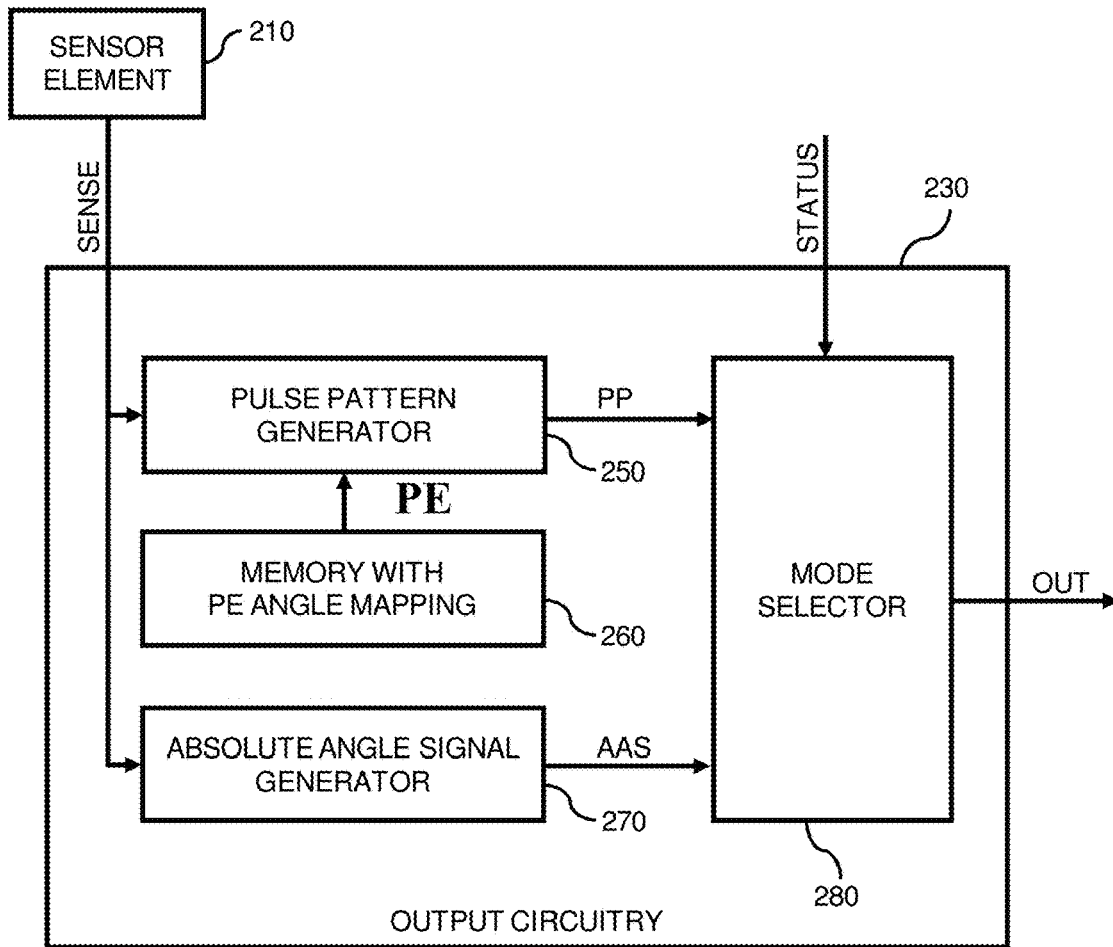

Fig. 2

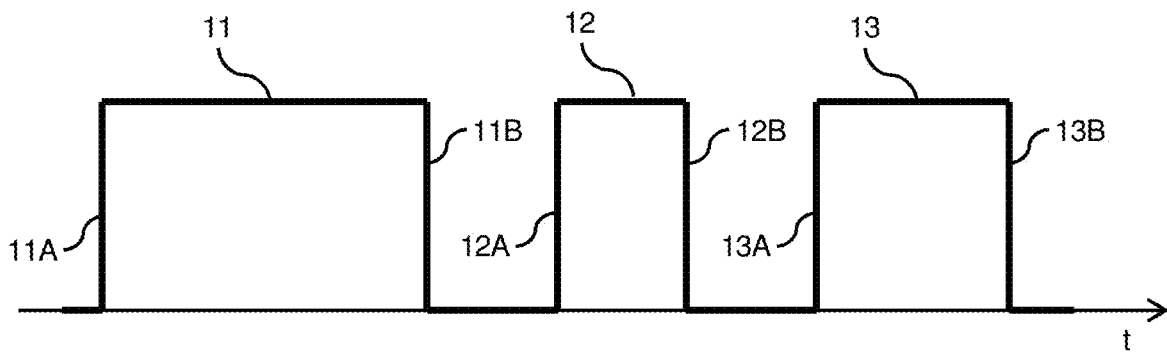

Fig. 3A

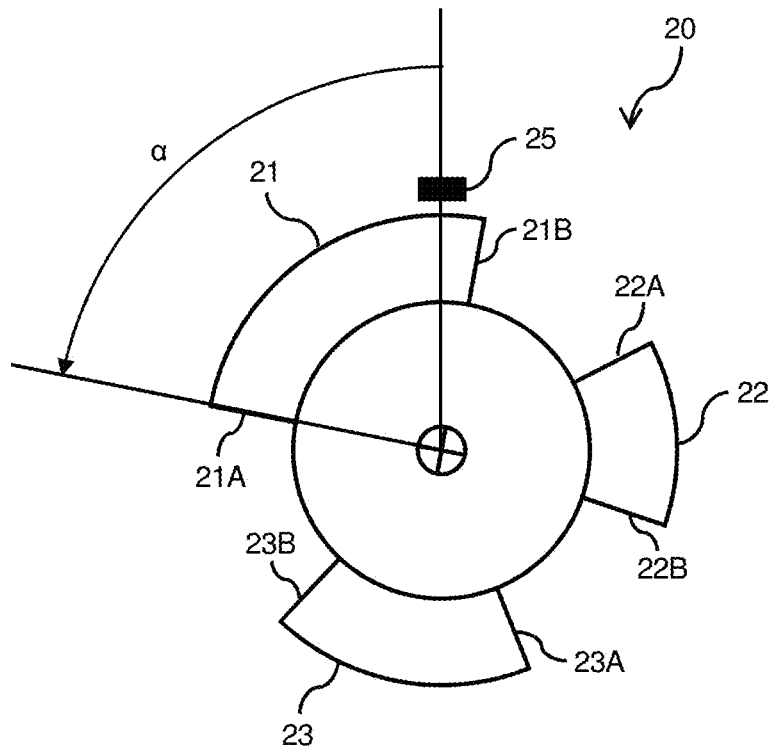

Fig. 3B

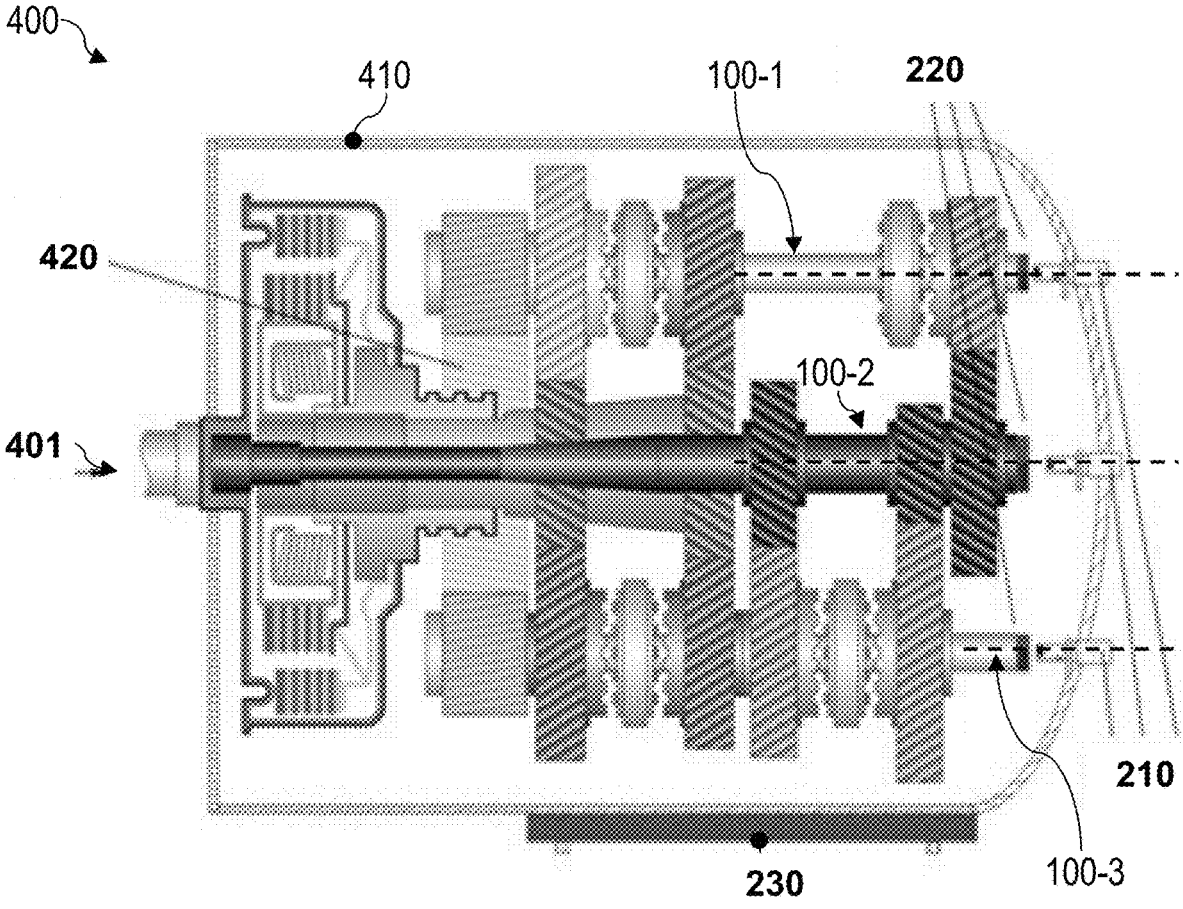

Fig. 4

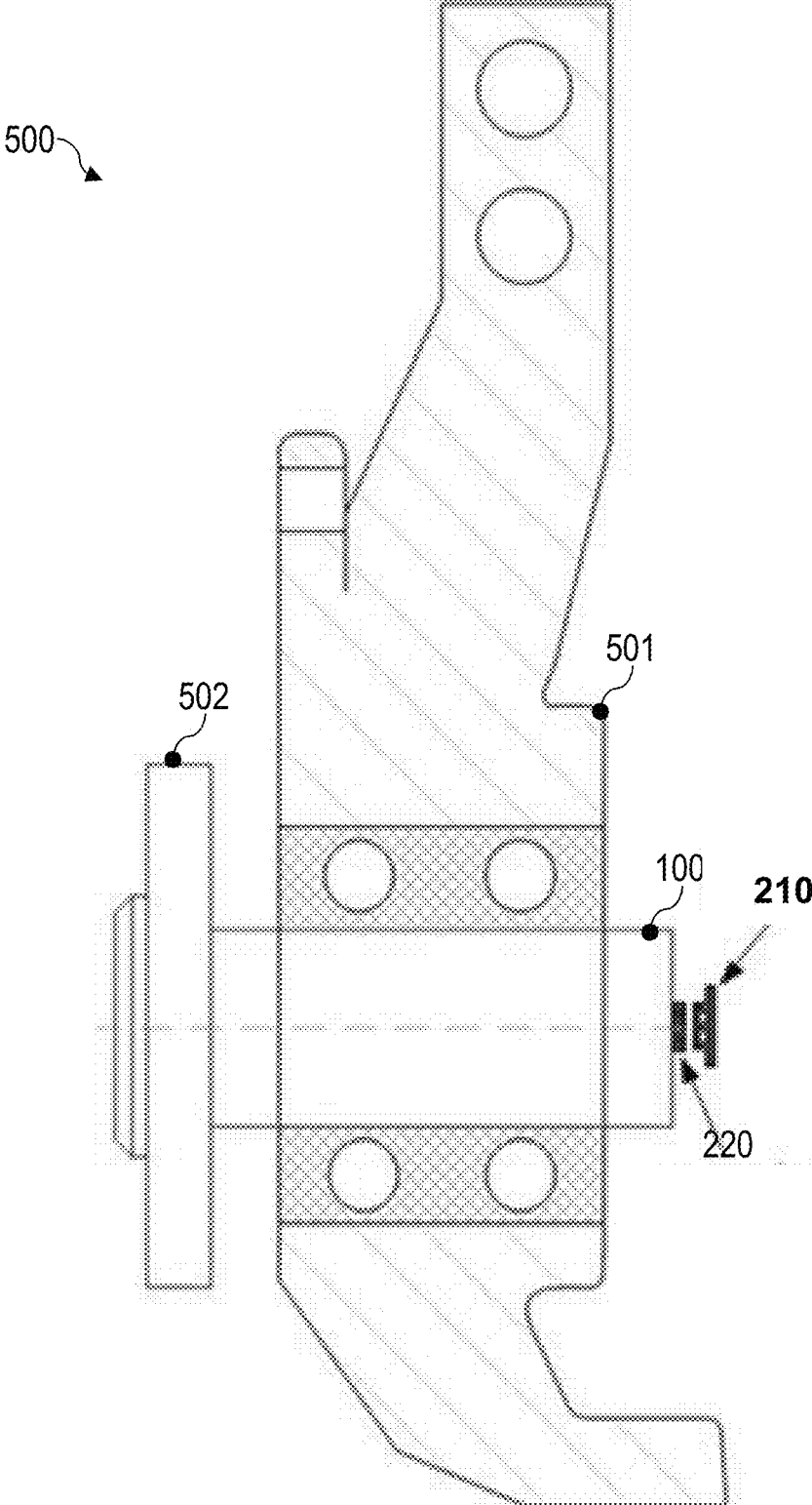

Fig. 5

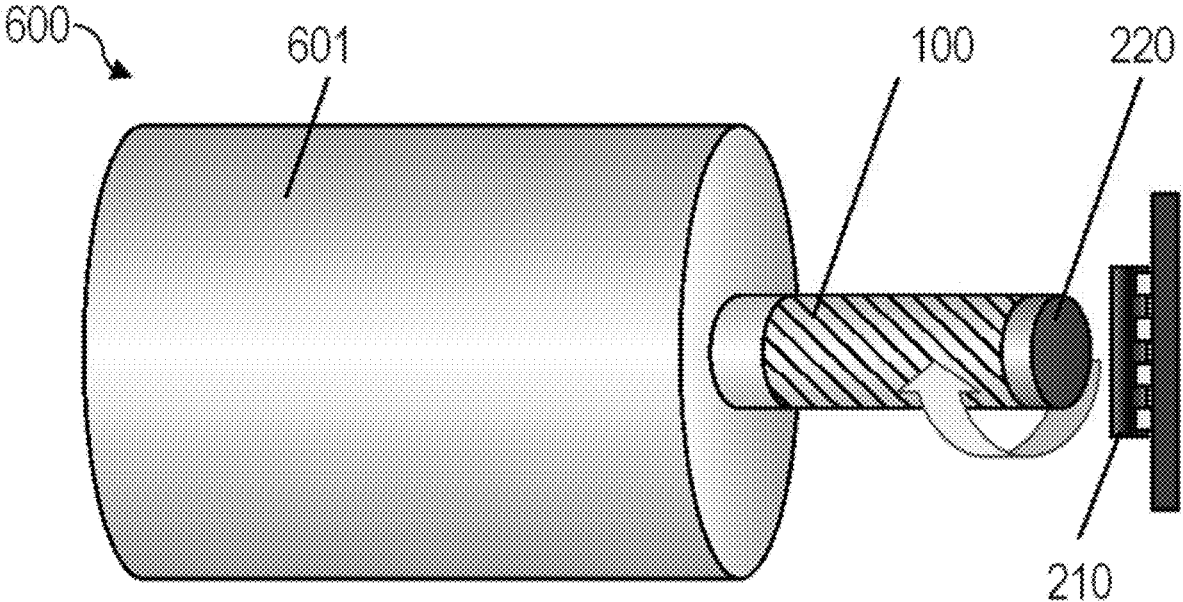

Fig. 6

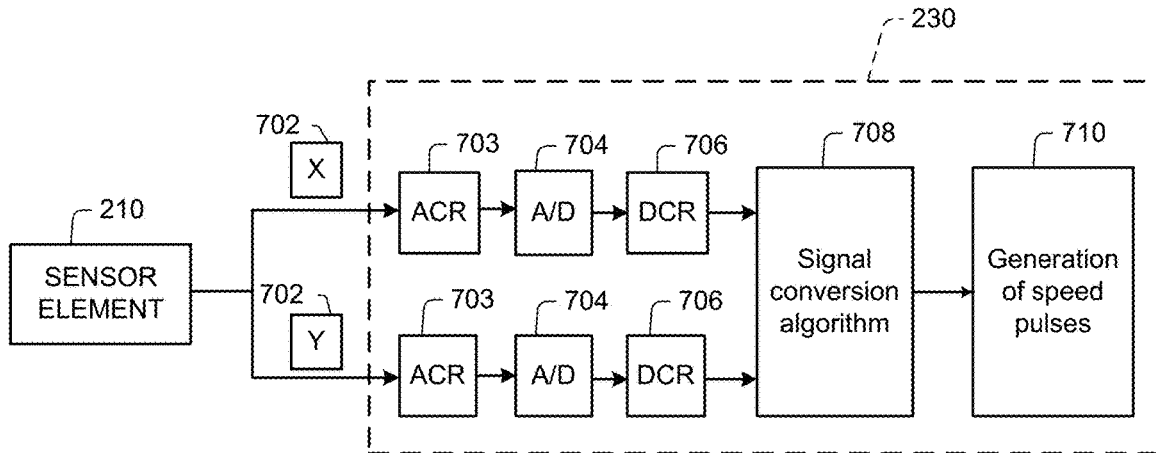

Fig. 7A

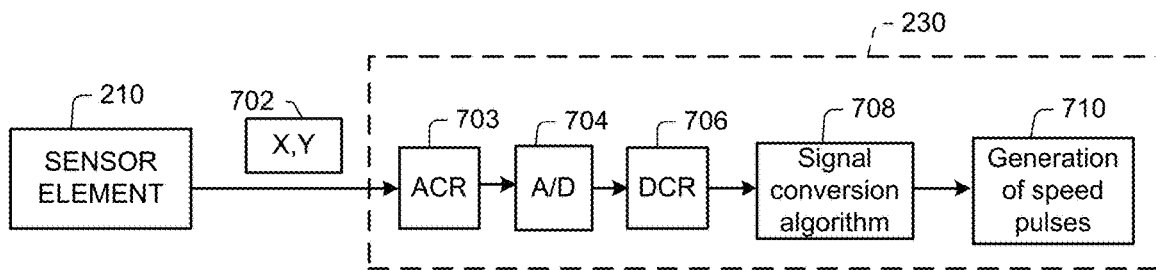

Fig. 7B

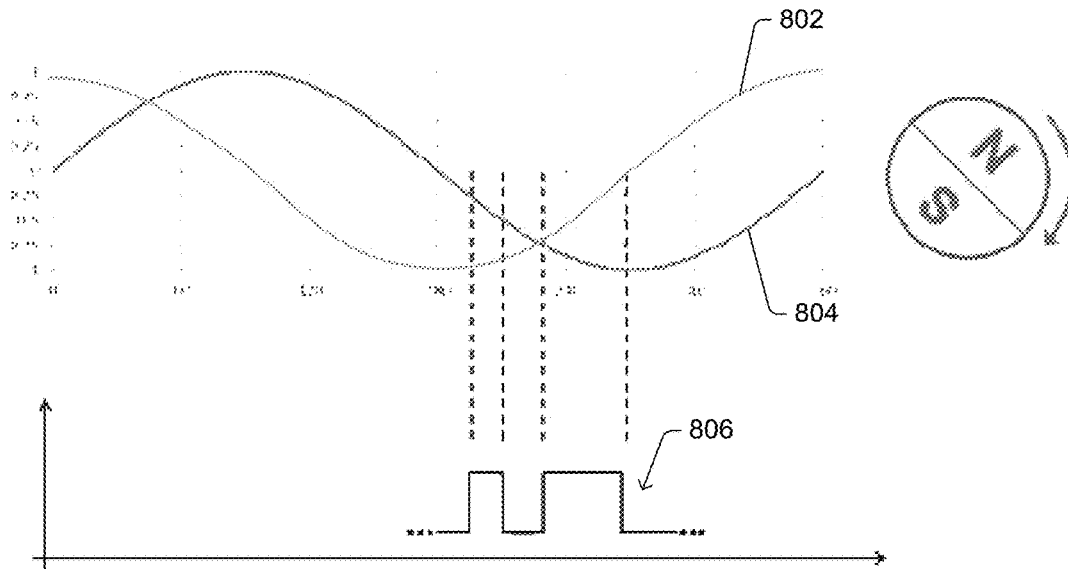
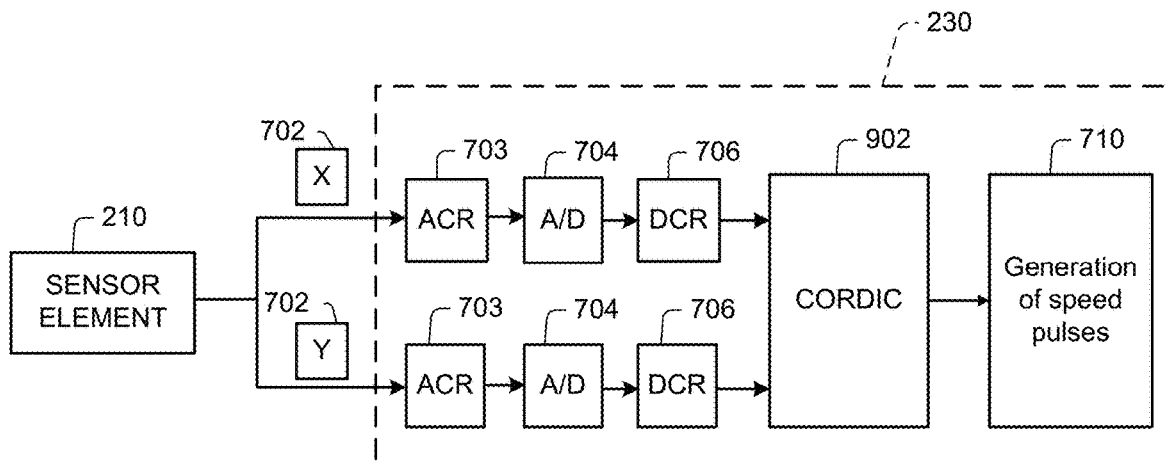
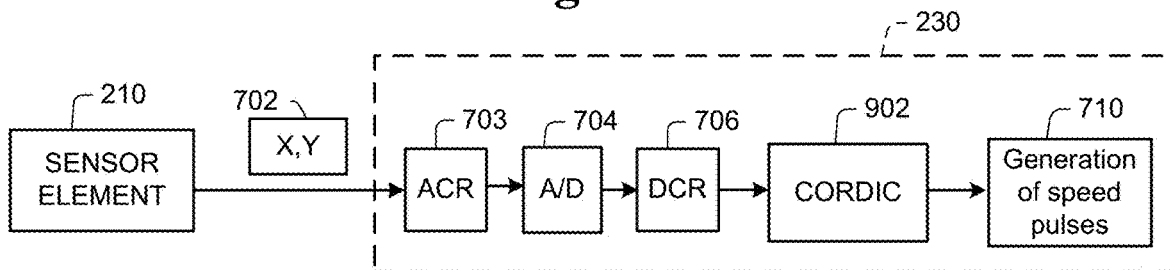

Fig. 8



**Fig. 9A**



**Fig. 9B**

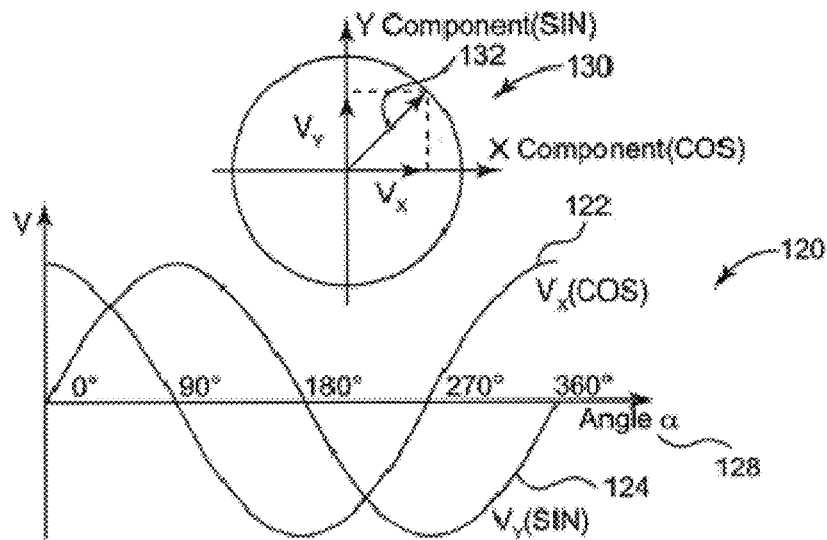

**Fig. 10**



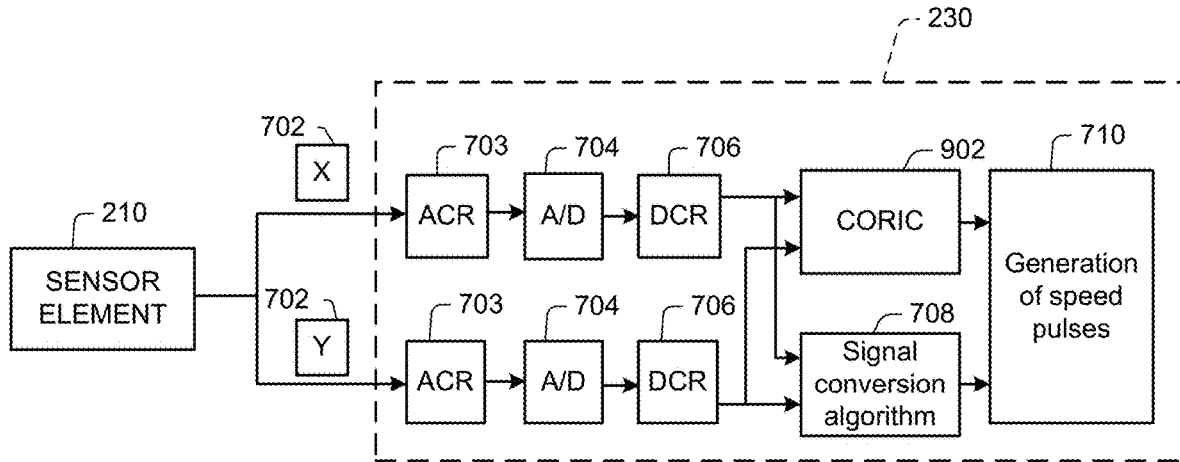

Fig. 11A

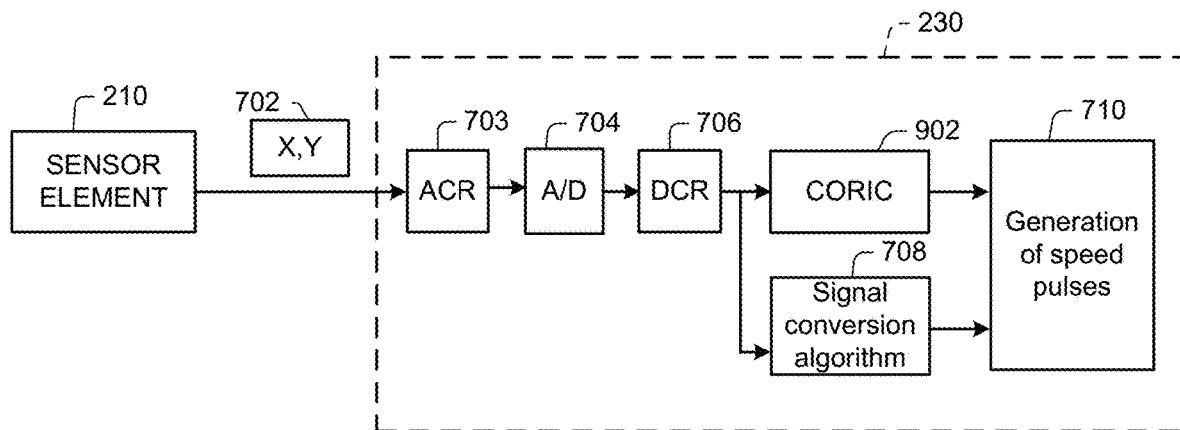

Fig. 11B

## ANGLE BASED SPEED SENSOR DEVICE

## SUMMARY

## CROSS REFERENCE TO RELATED APPLICATIONS

[0001] This Application is a Continuation of U.S. application Ser. No. 15/655,443, filed on Jul. 20, 2017, which is a Continuation-in-Part of U.S. application Ser. No. 14/306,442, filed on Jun. 17, 2014 (now U.S. Pat. No. 10,222,234, issued on Mar. 5, 2019). The contents of the above-referenced Patent Applications are hereby incorporated by reference in their entirety.

## FIELD

[0002] The present application relates to a sensor device and to a sensing system and to a method of processing a sensing signal.

## BACKGROUND

[0003] In various technological fields the rotation of a shaft is sensed. Various control functionality may rely on the sensed rotation of the shaft. For example, a rotational speed or angular velocity of a shaft of a transmission may be used to control the operation of the transmission. For example, an angular velocity of a shaft of a wheel axle may be used to monitor friction of the corresponding wheel; this may be useful for antiblocking systems or electronic stability systems in vehicles.

[0004] A known way of sensing rotation of the shaft is to place a ferromagnetic toothed wheel on the shaft and use a sensor to detect passing of teeth of the toothed wheel. Typically, the sensor is placed at a distance from the rotational axis of the shaft; often, the sensor is placed radially offset from the ferromagnetic toothed wheel. The output of such sensor typically corresponds to a pattern of pulses in which the frequency of pulses varies according to the speed of rotation. By giving the different teeth of the toothed wheel a size which is distinctive with respect to other teeth of the toothed wheel, it becomes also possible to distinguish between different angular positions in the course of a single rotation of the shaft. It is for example conceivable to make just one of the teeth different from the other, so that an angular position of the toothed wheel may be identified. Without any limitation, more than one of the teeth may be made identifiable whereby more than one of the angular positions are made identifiable.

[0005] However, evaluation of the rotation angle using such toothed wheel requires that the shaft is actually rotating. Sometimes, at least one full rotation is needed to determine the absolute orientation. Further, complex algorithms may be needed for accurately estimating the rotation angle from the sensed pattern of pulses. Also, the achievable accuracy may significantly depend on a manufacturing accuracy of the toothed wheel as well as a precision in mounting the sensor relative to the toothed wheel. Still further, the toothed wheels—sometimes also referred to as magnetic encoder wheels—may require significant space and may be comparably expensive.

[0006] Accordingly there is a need for techniques which allow for sensing rotation of a shaft in an efficient and accurate manner.

[0007] According to some embodiments, a sensor device is provided. The sensor device may comprise a magnetic field sensitive element to be positioned in a magnetic field of a magnet positioned on an end face of a shaft, the magnetic field sensitive element being configured to sense an orientation angle of the magnetic field in the range between  $0^\circ$  and  $360^\circ$  and generate a sensing signal comprising a first sensing signal component and a second sensing signal component which have a  $90^\circ$  phase shift. The sensor device may further comprise electronic circuitry. The electronic circuitry is configured to receive and process the sensing signal from the magnetic field sensitive element to generate an angle signal indicating the orientation angle of the magnetic field.

[0008] According to some further embodiments, a system is provided. The system may comprise a rotatable shaft and a magnet positioned on an end face of the shaft. The system may further comprise a magnetic field sensitive element positioned in a magnetic field of the magnet, the magnetic field sensitive element being configured to sense an orientation angle of the magnetic field in the range between  $0^\circ$  and  $360^\circ$  and generate a sensing signal. The system may further comprise electronic circuitry configured to receive and process the sensing signal from the magnetic field sensitive element to generate an angle signal indicating the orientation angle of the magnetic field. The electronic circuitry is configured to process the sensing signal by selecting different process methods depending on an angular speed of the shaft.

[0009] According to some further embodiments, an angular sensing method is provided. The angular sensing method comprises generating a sensing signal by a magnetic field sensitive element, the sensing signal comprising a first sensing signal component and a second sensing signal component which have a  $90^\circ$  phase shift from each other. The angular sensing method further comprises processing the sensing signal by electronic circuitry to generate an angle signal indicating an orientation angle of the magnetic field. The sensing signal is processed to generate the angle signal by selecting different process methods depending on an angular speed of the shaft.

## BRIEF DESCRIPTION OF THE DRAWINGS

[0010] FIG. 1 schematically illustrates a sensor device according to an embodiment of the disclosure.

[0011] FIG. 2 shows a block diagram for schematically illustrating functionalities of the sensor device according to some embodiments.

[0012] FIG. 3A shows an example pulse pattern in a signal generated by a sensor device according to an embodiment.

[0013] FIG. 3B schematically illustrates a ferromagnetic toothed wheel in combination with a sensor, the ferromagnetic toothed wheel having a profile substantially corresponding to the pulse pattern of FIG. 3A.

[0014] FIG. 4 schematically illustrates a system according to an embodiment comprising a sensor device and a shaft of a transmission of a vehicle.

[0015] FIG. 5 schematically illustrates a system according to an embodiment where a sensor device and a shaft of a wheel axle of a vehicle are provided.

**[0016]** FIG. 6 schematically illustrates a system according to an embodiment where a sensor device and a shaft of a brushless DC motor are provided.

**[0017]** FIG. 7A and FIG. 7B show block diagrams for schematically illustrating functionalities of the sensor device according to some alternative embodiments.

**[0018]** FIG. 8 shows an example signal generated by a sensor device according to some embodiments.

**[0019]** FIG. 9A and FIG. 9B show block diagrams for schematically illustrating functionalities of the sensor device according to some alternative embodiments.

**[0020]** FIG. 10 shows an example signal generated by a sensor device according to some alternative embodiments.

**[0021]** FIG. 11A and FIG. 11B show block diagrams for schematically illustrating functionalities of the sensor device according to some alternative embodiments.

**[0022]** While the invention is amenable to various modifications and alternative forms, specifics thereof have been shown by way of example in the drawings and will be described in detail. It should be understood, however, that the intention is not to limit the invention to the particular embodiments described. On the contrary, the intention is to cover all modifications, equivalents, and alternatives falling within the spirit and scope of the invention as defined by the appended claims.

#### DETAILED DESCRIPTION

**[0023]** In the following, various embodiments will be described in detail with reference to the accompanying drawings. It should be noted that these embodiments serve only as examples and are not to be construed as limiting. For example, while embodiments with a plurality of features, other embodiments may comprise less features and/or alternative features. Furthermore, features from different embodiments may be combined with each other unless specifically noted otherwise.

**[0024]** Embodiments as illustrated in the following relate to techniques of sensing the rotation of a shaft, in particular of a shaft of a transmission of a vehicle, of a shaft of a brushless DC motor, and of a shaft of a wheel axle of a vehicle. The illustrated embodiments cover corresponding sensor devices, systems, and methods.

**[0025]** In the illustrated embodiments, a magnetic field sensitive element is utilized which is positioned in a magnetic field of a magnet. The magnet is positioned on an end face of the shaft. The magnetic field sensitive element is configured to sense an orientation angle of the magnetic field in the range between 0° and 360°. From this angle, it may be possible to unambiguously determine the orientation of the magnetic field.

**[0026]** The magnetic field sensitive element may without any limitation be based on a magnetoresistive effect, such as the Giant Magnetoresistance (GMR) effect, Anisotropic Magnetoresistance (AMR) effect, Tunnel Magnetoresistance (TMR) effect, or Hall effect. An example embodiment of the magnetic field sensitive element could be based on two GMR devices with two different maximum sensitivity directions in a plane which is parallel to the end face of the shaft and perpendicular to a longitudinal direction and rotation axis of the shaft. Such a magnetic field sensitive element may allow for accurate detection of the orientation angle of the magnetic field of a magnet having a magnetization which is orientated perpendicular to the rotation axis of the shaft. In particular, such magnetic field sensitive element may be

used in a compass like manner to sense the orientation of the magnetic field of the magnet rotating together with the shaft.

**[0027]** Further, the illustrated embodiments may utilize a stored mapping of pulse edges to orientation angles. In some embodiments, the mapping can be configurable, For example, by programming the memory. Depending on this mapping and the orientation angle of the magnetic field as sensed by the magnetic field sensitive element, a first signal is generated which includes a pattern of pulses with rising and falling pulse edges. Within the first signal the rising and/or falling edges may be mapped to predefined orientation angles as sensed by the magnetic field sensitive element. The first signal may be used to emulate a pulse pattern as generated by a sensor assembly which is based on an asymmetric toothed wheel, as explained before. Such a form of the first thereby achieving compatibility to existing sensor devices relying on such asymmetric toothed wheels.

**[0028]** In addition, the sensed angular orientation may be used to generate a second signal which represents a rotation angle of the shaft in the range between 0° and 360°. In the latter case, the rotation angle may be represented by a digital value, an analog value, or a pulse width modulated signal. The pulse width modulated signal may, in other words, correspond to a pulse width modulated value. Different modes of operation may be provided for outputting either the first signal or the second signal. For example, a sensor device may be provided with a first mode of operation in which the sensor device outputs the first signal and a second mode of operation in which the sensor device outputs the second signal instead of the first signal. Likewise, the sensor may output both of the first signal and the second signal in yet another mode of operation.

**[0029]** In some embodiments, the orientation of the magnetic field as sensed by the magnetic field sensitive element may also be used as a basis for generating further signals. For example, depending on the sensed orientation angle, a further signal may be generated representing an angular speed of the shaft. The angular speed may without any limitation be represented by a digital value, an analog value, or a pulse width modulated signal. The further signal may have a predefined periodicity per revolution of the shaft. In other words, a repetition of basic building blocks—such as pulses or half-waves or full waves—of the signal may amount to a certain predefined number. As a non-limiting example, there may be a number of ten duty cycles per revolution. The predefined periodicity may allow emulating the output of a conventional sensor device operating based on a toothed wheel. The predefined periodicity may correspond to a number of teeth of the emulated toothed wheel.

**[0030]** The above embodiments will now be further explained with reference to the drawings.

**[0031]** FIG. 1 schematically illustrates a sensor device 200 according to an embodiment. The sensor device 200 is configured to sense rotation of a shaft 100, i.e., orientation and/or angular speed. Accordingly, the sensor device 200 in the following will also be referred to as a rotation sensor.

**[0032]** The shaft may be one of a shaft of transmission of a vehicle or a shaft of a brushless DC motor or a shaft of a wheel axle of a vehicle.

**[0033]** In the illustrated embodiment, the sensor device 200 includes a magnetic field sensitive element 210, in the following also referred to as sensor element, and a magnet 220. Further electronic circuitry 230 is provided in the illustrated embodiment. As illustrated, the magnet 220 may

be a disc-shaped dipole magnet mounted on an end face of the shaft **100**. The magnetization of the magnet **220** (from south pole “S” to north pole “N”) is oriented perpendicularly to the longitudinal rotation axis **110** of the shaft **100**. The magnetization may correspond to the internally acting magnetic field. A border between North and South pole of the magnet **220** may be oriented perpendicular to the magnetization. Accordingly, when the shaft rotates as indicated by the arrow, the orientation of the magnetic field of the magnet **220** changes in an anti-clockwise manner around the longitudinal rotation axis **110** of the shaft **100** (viewed in FIG. 1 from the distal end of the axis towards the magnet).

**[0034]** As mentioned above, the sensor element **210** may, For example, be based on two GMR devices each having a different maximum sensitivity direction in a plane which is perpendicular to the longitudinal rotation axis **110** of the shaft **100**, thereby allowing for sensing the absolute angle of the orientation of the magnetic field in a range from  $0^\circ$  to  $360^\circ$ .

**[0035]** The geometrical shape and the magnetic configuration of the magnet **220** are not particularly limited. As mentioned above, in the scenario of FIG. 1, a disc-shaped element forming a magnetic dipole is shown. One half of the disc forms the magnetic north pole N and the other half of the disc forms the magnetic south pole S. The magnetic axis, i.e., the geometrical connection between north pole S and south pole S, is oriented perpendicular to the axis of the shaft. It is also possible that magnetic multi-pole elements are used which comprise a plurality of north poles and corresponding south poles. This may increase a sensitivity and accuracy in the sensing of the orientation angle of the magnetic field. In such a scenario, the rotation sensor is typically preconfigured with information on a spatial shape of the magnetic field generated by the magnet **220**. In one embodiment, it may be desirable to use a flat element which radially extends with respect to the axis of the shaft **100**. This may allow sensing of the orientation even in situations where not much space is available. However, it is also possible that an element with a considerable thickness compared to its radial dimension is employed. As shown in the scenario of FIG. 1, a radial dimension of the magnet may be in the order of the radial dimension of the shaft **100**. However, in general it is also possible that the radial dimension of magnet **200** is considerably larger or smaller than the radial dimension of the shaft **100**. For example, in a scenario, a magnetic pill may be used as the magnet **200**. The magnetic pill may be a substantially elongate element where the magnetic poles are situated on opposing ends thereof. Elongate may refer to a substantially 1 d extended element. For example, the magnetic pill may be diametrically magnetized.

**[0036]** As can be seen from FIG. 1, the sensor element **210** is positioned at an axial extension of the shaft **100** (as indicated by the dashed line in FIG. 1) and is offset by a gap with respect to the magnet **220**. In particular, the sensor element **210** may be stationary while the shaft **100** rotates, as illustrated in FIG. 1.

**[0037]** Further, the sensor device **200** may include the electronic circuitry **230** which is configured to generate various kinds of output signals from the orientation angle of the magnetic field as sensed by the sensor element **210**. In some embodiments, the electronic circuitry **230** is arranged remotely from the sensor element **210** and is configured to have signal communications with the sensor element **210**. In

some other embodiments, the electronic circuitry **230** is integrated in a chip attached to the sensor element **210**. The sensor element **210** and the electronic circuitry **230** may also be arranged on the same semiconductor chip or in the same chip package. Some embodiments of functionalities of the electronic circuitry **230** are further illustrated by the block diagram of FIG. 2 according to some embodiments.

**[0038]** As illustrated in FIG. 2, the electronic circuitry **230** may include a pulse pattern generator **250** and a memory **260**. The pulse pattern generator **250** is configured to generate a signal PP which includes a pattern of pulses. This is accomplished depending on the sensed orientation angle of the magnetic field, in FIG. 2 represented by signal SENSE, and a pulse edge (PE) angle mapping as stored in the memory **260**. The memory **260** may for example be implemented by a suitable type of semiconductor memory, such as a Read Only Memory (ROM), a Programmable ROM (PROM), an Erasable PROM (EPROM), or a flash memory. An embodiment of the memory **260** using PROM, EPROM, or flash memory may be used to allow configuration or even reconfiguration of the PE angle mapping stored in the memory **260**.

**[0039]** In the illustrated embodiment, the PE angle mapping stored in the memory **260** defines, for each pulse of the pulse pattern, an orientation angle associated with a rising edge of the pulse and an orientation angle associated with a falling edge of the pulse. Accordingly, the pulse pattern generator **250** may operate by comparing the sensed orientation to the orientation angles in the mapping and, if the sensed orientation angle passes an orientation angle corresponding to a rising edge, switching the value of the signal PP to a high value or, if the sensed orientation angle passes an orientation angle corresponding to a falling edge, switching the value of the signal PP to a low value. In this way, various kinds of pulse patterns may be generated, including highly asymmetric pulse patterns in which, over the course of a complete rotation of the shaft **100**, each pulse differs from the other pulses with respect to its duty cycle.

**[0040]** As further illustrated, the electronic circuitry **230** may also include an absolute angle signal generator **270** which is configured to generate a signal AAS which represents the absolute orientation angle of the shaft **100** in the range from  $0^\circ$  to  $360^\circ$ . The signal AAS may, for example, represent the absolute orientation angle of the shaft **100** as an analog value. Further, the signal AAS may encode the absolute orientation angle of the shaft **100** as a digital value or a pulse width modulated signal. The absolute angle signal generator **270** may derive the absolute orientation angle of the shaft **100** from the orientation angle of the magnetic field as sensed by the sensor element by, For example, adding an offset which takes into account the mounting orientation of the magnet **220** on the shaft **100** and/or any further reference offset. The absolute angle signal generator **270** may also perform signal conversion, For example, from an analog representation of the signal SENSE to a digital or pulse width modulated representation of the signal AAS, as non-limiting examples. Alternatively or additionally, the pulse pattern generator **250** may perform the signal conversion.

**[0041]** In some embodiments, the absolute angle signal generator **270** may also be configured to generate one or more further signals from the orientation angle sensed by the sensor element **210**. For example, the absolute angle signal generator **270** may generate a signal representing the angular speed of the shaft **100**, For example, by calculating the time

derivative of the absolute orientation angle of the shaft **100**. Optionally, a direction of the rotation may be encoded. In order to emulate the output signal obtained with the conventional sensor element interacting with a toothed wheel, it is, For example, possible that the absolute angle signal generator **270** outputs the signal representing the angular speed of the shaft **100** such that it has a predefined number of periods per revolution of the shaft, as a non-limiting example 12 or 20 periods. Such a signal may be suited to emulate the signal obtained with a conventional absolute angle signal generator interacting with a toothed wheel having a corresponding number of teeth.

**[0042]** As further illustrated, the electronic circuitry **230** of FIG. **2** may include a mode selector **280**. The mode selector **280** may be used for selecting different operating modes of the electronic circuitry **230**. In particular, the mode selector **280** may be used for selecting a first operating mode, in which the electronic circuitry **230** outputs the signal PP as its output signal OUT. The mode selector **280** may further be used for selecting a second operating mode, in which the output circuitry may output the signal AAS as its output signal OUT. Optionally, the mode selector **280** may be used for selecting a third operating mode, in which the electronic circuitry **230** outputs the further signal which is indicative of the rotational speed.

**[0043]** Various decision criteria used by the mode selector **280** in order to select a particular operating mode are conceivable. For example, in a start-up phase of the rotation of the shaft, the mode selector **280** may select the second operating mode, thereby providing useful information on the rotation angle of the shaft **100** even when the shaft is substantially static, which means that the signal PP may not yet have a sufficient number of pulses for a relation of the rotation angle. After a certain number of rotations of the shaft **100**, For example, after one complete rotation, or when an angular speed of the shaft **100** exceeds a threshold value, the mode selector **280** may select the first operation mode, in which the output signal OUT may be generated to emulate an output signal as typically provided by conventional toothed wheel-based rotation sensors.

**[0044]** It is also possible that the electronic circuitry **230** outputs a plurality of signals. For example, the signal AAS may be output and the further signal may be output in one and the same operation mode. Then it may be possible to derive, both, the orientation as well as the rotational speed.

**[0045]** An example pulse pattern as included in the signal PP is illustrated in FIG. **3A**. This pulse pattern is assumed to emulate an output signal of a rotation sensor **25** arranged in the magnetic field of a toothed wheel **20** as schematically illustrated in FIG. **3B**. In the illustrated example, the pulse pattern consists of three pulses **11**, **12**, **13**, having a different duty cycle each. Each pulse **11**, **12**, **13** corresponds to a particular tooth **21**, **22**, **23** of a toothed wheel **20** used with rotation sensor **25**. In the given example, the pulse **11** corresponds to tooth **21** of the toothed wheel **20**, the pulse **12** corresponds to tooth **22** of the toothed wheel **20**, and the pulse **13** corresponds to tooth **23** of the toothed wheel **20**.

**[0046]** On the toothed wheel **20** shown in FIG. **3B** the teeth **21**, **22**, **23** each have two edges **21A**, **21B**, **22A**, **22B**, and **23A**, **23B** extending in a substantially radial direction with regards to the axis. Each pair of edges **21A**, **21B**, **22A**, **22B**, and **23A**, **23B** defines an angular position and circumferential extension of the respective tooth **21**, **22**, **23**. If during rotation of the toothed wheel **20** the rotation angle  $\alpha$

increases, the teeth **21**, **22**, **23** subsequently pass a sensor **25**. For example, the sensor **25** can be a Hall sensor, a GMR sensor, a TMR sensor, or AMR sensor and at least the teeth **21**, **22**, **23** of the toothed wheel **20** may be formed of a ferromagnetic material. The pulse pattern of a typical output signal of such a system setup is emulated by the signal PP, as illustrated in FIG. **3A**. In the illustrated example, the pulse pattern of FIG. **3A** has a rising pulse edge **11A** of the pulse **11** at a time when the edge **21A** of the tooth **21** would pass the sensor **25**, and has a falling pulse edge **11B** at a time when the edge **21B** of the pulse **21** would pass the sensor **25**. Similarly, the pulse pattern of FIG. **3A** has a rising pulse edge **12A** of the pulse **12** at a time when the edge **22A** of the tooth **22** would pass the sensor **25**, and has a falling pulse edge **12B** at a time when the edge **22B** of the pulse **22** would pass the sensor **25**. Similarly, the pulse pattern of FIG. **3A** has a rising pulse edge **13A** of the pulse **13** at a time when the edge **23A** of the tooth **23** would pass the sensor **25**, and has a falling pulse edge **13B** at a time when the edge **23B** of the pulse **23** would pass the sensor **25**.

**[0047]** The electronic circuitry **230** of the illustrated embodiment may achieve emulation by suitably configuring the PE angle mapping stored in the memory **260**. For example, when assuming that the edge **21A** of the tooth **21** is located at an angular position of  $0^\circ$ , the PE angle mapping may assign a rising pulse edge **11A** to the orientation angle of  $0^\circ$ . Similarly, if the edge **21B** of the tooth **21** is located at an angular position of  $90^\circ$ , the PE angle mapping may assign falling pulse edge **11B** to the orientation angle of  $90^\circ$ . For the other teeth **22**, **23** corresponding assignments may be done depending on the angular position and circumferential extension of the teeth **22**, **23**. In such an assignment of rising and falling pulse edges, also an offset between the orientation angle of the magnetic field and the rotation angle of the shaft **100** may be taken into account. The offset may relate to a difference of the orientation angle and the rotation angle. The offset may be taken into account by a predefined reference angle used for calibration of the PE angle mapping.

**[0048]** It is to be understood that the pulse pattern of FIG. **3A** would be repeated with each revolution of the shaft **100**. Further, the pulse widths and pauses in the pulse pattern would vary according to the rotation speed of the shaft **100**. For example, the ratio of pulses to pauses per revolution may remain constant.

**[0049]** FIG. **7A** and FIG. **7B** illustrates block diagrams showing some alternative embodiments of functionalities of the electronic circuitry **230** including a threshold based method to compensate for non-linear pulse-width ratio and ambiguous signal information around the minimum and maximum points. As illustrated in the figures, the sensor element **210** senses the rotation of a target (for example, the shaft **100** in FIG. **1**) and generates a first sensing signal component X and a second sensing signal component Y as shown by blocks **702**. The first sensing signal component X and the second sensing signal component Y are then prepared for rotation angle extraction, including analog correction and optimization functions before converting to digital signals, and digital correction and optimization functions after converting to digital signals. The correction and optimization functions may include but are not limited to filtering, self-calibration, and temperature compensation which can be processed either in analog domain or in digital domain. For example, the first sensing signal component X

and the second sensing signal component Y can be respectively fed into analog correction blocks 703 for filtering and self-calibration, then be fed into A/D conversion blocks 704, and then fed into digital correction blocks 706 for temperature compensation. It is understood that the sequence and selection of those correction and optimization functions are not limited to the examples given above. Instead, any applicable sequence and selection of correction and optimization functions are amenable for this application. It is also understood that whether to process the first sensing signal component X and the second sensing signal component Y in parallel (e.g. processing X and Y through separate blocks as shown in FIG. 7A), in sequence (e.g. processing X and Y one after another through a shared function block as shown in FIG. 7B), or in combination (e.g. some of the function blocks are shared while others are separate) can vary depending on applications. Similarly, the correction and optimization processing of the first sensing signal component X and the second sensing signal component Y associated with FIGS. 9A-B and FIGS. 11A-B below is shown in the corresponding figures as non-limiting examples, but other alternative embodiments similar to what are discussed above are amenable.

[0050] As an example shown in FIG. 8, the result can be (normalized) sine curve  $V_x(\cos \alpha)$  802 and cosine curve  $V_y(\sin \alpha)$  804 of a voltage amplitude. The generated sensing signal corresponds an orientation angle of the magnetic field in the range between  $0^\circ$  and  $360^\circ$ . The angle  $\alpha$  is a rotation angle of the magnetic field, i.e., a rotation angle of the target to be sensed. As shown in FIG. 8, an angle position is extracted from one of the signal components (e.g., the second sensing signal component  $V_y(\sin \alpha)$ ) 804 by a signal conversion algorithm block 708. For instance, for every quarter of the sinusoidal signal a pulse or a series of pulses 806 is generated. The sinusoidal base function causes a non-linear pulse-width ratio of the generated pulse. Compensated threshold values are either stored in a look-up table or a threshold based algorithm to generate correct amplitude values in order to achieve a linearized pulse width and extract correct phase values. The look-up table may be stored in a memory integrated in the electronic circuitry 230, such as a Read Only Memory (ROM), a Programmable ROM (PROM), an Erasable PROM (EPROM), or a flash memory. An embodiment of the memory using PROM, EPROM, or flash memory may be used to allow configuration or even reconfiguration of the look-up table stored in the memory. As the inventor have appreciated, the speed information is not particularly close to the signal minimum and maximum points. To solve this problem, the other signal component (e.g., the first sensing signal component  $V_x(\cos \alpha)$ ) 802 which is  $90^\circ$  phase shifted relative to the above signal component, is added to the signal interpretation. This provides correct speed information for full revolution. With sine and cosine data available a simple threshold based algorithm can be applied to provide unambiguous angle information.

[0051] The angle information can be used to generate speed pulse signals (as shown by a generation of speed pulses block 710 in FIG. 7A,B), absolute angle information, direction information, and/or acceleration information (not shown in FIG. 7A,B). For example, in some embodiments, an absolute orientation angle indicating the absolute angle of the target to be sensed can be derived from the orientation angle of the magnetic field as sensed by the sensor element

by adding a predetermined reference offset. The absolute orientation angle can be generated as an analog value, or can be encoded as a digital value or a pulse width modulated signal.

[0052] The threshold based method provides flexibility to extract different levels of accuracy. For instance, the accuracy of the speed sensing can be dynamically controlled by selecting large quantization steps during high speed operation and smaller quantization steps at lower speeds. The linearized look-up table values provide equidistant speed pulse signals.

[0053] FIG. 9A and FIG. 9B illustrate block diagrams showing some alternative embodiments of functionalities of the electronic circuitry 230 including a CORDIC based method to calculate correct angle position with the use of arctan functionality.

[0054] As illustrated in FIG. 9A and FIG. 9B, the sensor element 210 senses the rotation of a target (for example, the shaft 100 in FIG. 1) and generates a first sensing signal component X and a second sensing signal component Y as shown by blocks 702. The first sensing signal component X and the second sensing signal component Y are fed into A/D conversion blocks 704 and subsequently temperature compensation, filtering and/or self-calibration blocks 706. The first sensing signal component X and the second sensing signal component Y are then fed into a CORDIC block 902 to extract an angle information signal. The angle information signal can then be fed into some further processing blocks such as a generation of speed pulses block 710 to generate speed pulse signals, as well as absolute angle information, direction information, and/or acceleration information. The first sensing signal component X and the second sensing signal component Y can be sine and cosine curves  $V_x(\cos \alpha)$  and  $V_y(\sin \alpha)$  which have a  $90^\circ$  phase shift of a voltage amplitude over a rotation angle  $\alpha$  as an example shown in FIG. 10.

[0055] As shown in FIG. 10, a graph 120 illustrates "ideal" output signals  $V_x(\cos)$  122 and  $V_y(\sin)$  124 provided by the sensor element 210 as the target to be sensed (e.g. the shaft 100 shown in FIG. 1) rotates from 0 to 360 degrees, as indicated by an angle  $\alpha$  at 128. As illustrated by the graph at 130, the output signals  $V_x(\cos)$  122 and  $V_y(\sin)$  124 respectively represent X and Y components of a vector 132 indicative of an angular position of the target to be sensed. A Volder's algorithm, also known as CORDIC (coordinate rotation digital computer) algorithm is used by the CORDIC block 902 to calculate and generate the angle information signal indicating the angular position of the target to be sensed.

[0056] The CORDIC based method can be effectively implemented on ASIC level and provides a more robust and higher accuracy angle and/or speed sensing. A kind of dynamic accuracy control can also be provided by using the CORDIC based method: for high speed operation only rough angle information is provided while at lower speeds more data is transmitted to achieve the angle information with higher resolution.

[0057] FIG. 11A and FIG. 11B illustrate block diagrams showing some alternative embodiments of functionalities of the electronic circuitry 230 including an advanced dynamic control method to calculate a correct angular position with a combination of a threshold based functionality and a CORDIC functionality. For example, a simple look-up table detection is used at a higher speed range to simplify process

and improve speed, while a CORDIC operation is used at a lower speed range to achieve the high angle accuracy.

**[0058]** The electronic circuitry **230** may include a dynamic controller. The dynamic controller may be used for selecting different process methods, depending on an angle change rate, a speed of the target to be sensed, or a safety function among other criteria. The dynamic controller can operate in a first mode and process the sensing signal using the CORDIC based method disclosed above in FIG. 9A, FIG. 9B and FIG. 10 when a pre-set criterion is met, and is switched to a second mode and process the sensing signal using the threshold based method disclosed above in FIG. 7 and FIG. 8 when the pre-set criterion is not met. For example, the dynamic controller can process the sensing signal using the CORDIC based method when the sensed speed is smaller than a pre-determined threshold value such that a higher resolution result is achieved, and is switched to process the sensing signal using the threshold based method when the sensed speed is greater than the pre-determined threshold value such that a lower latency time is achieved. As another example, the dynamic controller can process the sensing signal using the threshold based method when the safety function demands measured rotation angles at a greater sensing rate. The dynamic controller can also process the sensing signal using the CORDIC based method when the safety function demands measured rotation angles at a higher resolution.

**[0059]** In alternative embodiments, the threshold based method and the CORDIC based method can be concurrently applied to measure rotation angles. A first rotation angle and a second rotation angle, which can be measured substantially at the same time using the threshold based method and the CORDIC based method, can be compared for a plausibility safety check: for example, if a difference between the first rotation angle and the second rotation angle are within a pre-determined range, the measurement can be considered as reliable. Otherwise, if the difference between the first rotation angle and the second rotation angle falls outside of the predetermined range, an error may be flagged. In some alternative embodiments, one of the threshold based method or the CORDIC based method can be used for the plausibility safety check. In these alternative embodiments, the measured rotation angle can be compared with an additional rotation angle which is measured at substantially the same time but which is measured from another measurement source. The measured rotation angle can then be compared to the additional rotation angle to yield a comparison result, which can be evaluated to determine the reliability of the measured rotation angle. In some embodiments, the rotation angles measured at substantially the same time using the threshold based method, the CORDIC based method, and/or other measurement sources are processed to generate an adjusted rotation angle for further processing. The adjusted rotation angle is generated without the reliability check or after the reliability check of the measured rotation angles. The adjusted rotation angle may be calculated by averaging the measured rotation angles. The adjusted rotation angle may also be calculated by selectively omitting some of the measured rotation angles (e.g. omitting measured rotation angles that fall out a pre-determined range) and averaging the remaining of the measured rotation angle. The averaging calculation can be performed either evenly or by assigning different weights to the measured rotation angles. The electronic circuitry **230** may also include a mode selector for

selecting different operating modes, such as outputting speed pulse signals, absolute angle information, direction information, and/or acceleration information.

**[0060]** The advanced dynamic control method combines the features of the threshold based method and the CORDIC based method disclosed above, and in addition adds the flexibility to switch between both of these methods. Similar as described above, a sensor element **210** senses the rotation of a target (for example, the shaft **100** in FIG. 1) and generates a first sensing signal component X and a second sensing signal component Y as shown by blocks **702**. The first sensing signal component X and the second sensing signal component Y are fed into A/D conversion blocks **704** and subsequently temperature compensation, filtering and/or self-calibration blocks **706**. During low speed operation, the first sensing signal component X and the second sensing signal component Y are then fed into a CORDIC block **902** to extract an angle information signal, such that the higher achievable resolution of the CORDIC implementation can be used. While for higher speeds, the first sensing signal component X and the second sensing signal component Y are fed into a signal conversion algorithm block **708** to extract an angle information signal, such that the low latency response of a simple and fast threshold based algorithm is an advantage. The decision which signal path will be used is handled by a speed dependent protocol block **1102** shown at the very end in FIG. 11. In addition, this chip concept may provide additional redundancy for functional safety requirements. For instance, while the high accuracy CORDIC angle information is used the lower accuracy threshold based signal path can be used for plausibility checks.

**[0061]** In FIG. 4, a transmission **400** in the form of a gear box is shown. An input shaft **401** is driven by an engine of a vehicle (not shown in FIG. 4). A transmission output wheel **420** is shown. There are three shafts **100-1**, **100-2**, **100-3** of the transmission **400**. Each one of the three shafts **100-1**, **100-2**, **100-3** is equipped with a magnet **220** on an end face thereof. A housing **410** rotatably houses the shaft **100-1**, **100-2**, **100-3**. At least parts of the shaft rotate within the housing. In other words, the housing **410** does not rotate together with the shafts **100-1**, **100-2**, **100-3**, it rather encloses an end portion of the shafts **100-1**, **100-2**, **100-3**. A respective bearing may be provided. The magnetic sensor elements **210** associated with the respective three magnets **220** are attached to the housing **410**. While FIG. 4 shows the magnet **220** on an end face of each one of the shafts **100-1**, **100-2**, **100-3**, the magnet may without limitation be provided on only some of the shafts. In particular, the sensor elements **210** are positioned at an axial extension of the respective shaft **100-1**, **100-2**, **100-3** (illustrated in FIG. 4 by the dashed lines) offset by a gap with respect to the magnet **220**. It is possible that the sensor elements **210** are displaced against the axial extension of the respective shaft **100-1**, **100-2**, **100-3**. By techniques as mentioned above, it is possible to determine the orientation and/or the rotational speed of the shafts **100-1**, **100-2**, **100-3**.

**[0062]** In FIG. 5, a system **500** comprising a shaft **100** of a wheel axle is shown. An end face of the shaft **100** is provided with the magnet **220**. The end face of the shaft **100** is opposite to a wheel bearing **502** of the wheel axle. The shaft **100** is rotatably connected to an axle carrier **501** between the end face and the wheel bearing **502**. Further illustrated in FIG. 5 is the sensor element **210** which is positioned at an axial extension of the shaft **100** and offset

by a gap with respect to the magnet **200**. The sensor element **210** does not rotate together with the shaft **100**. By the techniques as mentioned above, it is possible to determine the orientation and/or the rotational speed of the shaft **100**.

**[0063]** Turning to FIG. 6, a brushless DC motor unit or assembly **600** is shown. A motor **601** of the assembly may be attached to the shaft **100**. At the end face of the shaft, the magnet **220** is positioned. At an axial extension of the shaft **100** and offset by a gap, the sensor element **210** is positioned. By techniques as mentioned above, it is possible to determine the orientation and/or the rotational speed of the shaft **100**.

**[0064]** A controller (not shown in FIG. 6) of the brushless DC motor assembly **600** may continuously switch a phase of electrical windings to keep the motor **601** turning. The switching may occur in response to the orientation of the shaft **100**. By determining the orientation angle of the magnetic field in the range of between  $0^\circ$  and  $360^\circ$  employing the sensor element **210**, it becomes possible to determine the orientation angle of the shaft **100**. This allows for accurate control of the brushless DC motor **601**.

**[0065]** As can be seen from the above, the techniques may reduce complexity, required space, and costs when sensing the orientation of shafts **100**, **100-1**, **100-2**, **100-3**. Significantly less space than in conventional transmissions may be required in the scenario of FIG. 4 with the magnets **220** placed on one or more end faces of the shafts **100-1-100-3** of the transmission **400**. In particular, when employing toothed wheels, it may be necessary to occupy additional space on the shafts **100-1-100-3** to mount the latter. Typically, the toothed wheels (as shown in FIG. 3B) are limited to a minimum diameter of approximately 7 cm. Often, when employing conventional magnetic field sensors in the proximity of such toothed wheels, large sensor towers are required in order to bring the magnetic field sensors closer to the toothed wheel. Extra costs are generated and a system complexity typically increases. Further, there is a constant demand for downsizing transmissions **400**. When employing a system as mentioned above, both, complexity and required space may be reduced.

**[0066]** Further, in the scenario of FIG. 5, with the magnet **220** being attached to an end face of the shaft **100** of the wheel axle, significantly reduced space and costs are achieved when compared to conventional solutions. In particular, in conventional systems, a toothed wheel is often arranged close to the wheel bearing **502**. Typically, this affects overall system dimensions such as increased construction space. Consequently, complexity and the costs are further increased. The respective sensor in conventional systems is further located close to the braking system including the brake disc, brake caliper, and brake shoes; this often results in a high temperature environment. The accuracy of the sensing of the orientation may degrade and an increased wear out of the electronics may result.

**[0067]** In some embodiments, the disclosure is related to a sensor device. The sensor device includes a magnetic field sensitive element to be positioned in a magnetic field of a magnet positioned on an end face of a shaft, the magnetic field sensitive element sensing an orientation angle of the magnetic field in a range between  $0^\circ$  and  $360^\circ$  and generating a sensing signal comprising a first sensing signal component and a second sensing signal component which have a  $90^\circ$  phase shift. The sensor device further includes electronic circuitry receiving and processing the sensing

signal from the magnetic field sensitive element to generate an angle signal indicating the orientation angle of the magnetic field and an angular speed of the shaft.

**[0068]** In some further embodiments, the disclosure is related to a system. The system includes a rotatable shaft, a magnet positioned on an end face of the shaft, and a magnetic field sensitive element positioned in a magnetic field of the magnet, the magnetic field sensitive element sensing an orientation angle of the magnetic field in a range between  $0^\circ$  and  $360^\circ$  and generating a sensing signal. The system further includes electronic circuitry receiving and processing the sensing signal from the magnetic field sensitive element to generate an angle signal indicating the orientation angle of the magnetic field by selecting a process method depending on an angle change rate, an angular speed of the shaft, or a safety function.

**[0069]** In some further embodiments, the disclosure is related to an angular sensing device. The angular sensing device includes a magnet positioned on an end face of a shaft, a magnetic field sensitive element positioned in a magnetic field of the magnet, the magnetic field sensitive element generating a sensing signal, and electronic circuitry determining an angular speed of the shaft, selecting a process method based on the angular speed of the shaft, and processing the sensing signal according to the selected process method to generate an angle signal indicating an orientation angle of the magnetic field.

**[0070]** It is to be understood that the above-described concepts and embodiments are susceptible to various modifications. For example, various pulse patterns corresponding to various kinds of toothed wheel profiles could be emulated. Such emulation may also be extended to not only emulate the angular position and extension of teeth, but could also emulate further characteristics of the tooth profile, such as a radial dimension of the tooth or slope of the tooth edges. Further, the rotation sensor could use other kinds of sensing devices or other types of magnets, such as more complex multi-pole magnets.

What is claimed is:

1. A sensor device, comprising:

a magnetic field sensitive element to be positioned in a magnetic field of a magnet positioned on an end face of a shaft, the magnetic field sensitive element sensing an orientation angle of the magnetic field in a range between  $0^\circ$  and  $360^\circ$  and generating a sensing signal comprising a first sensing signal component and a second sensing signal component which have a  $90^\circ$  phase shift; and

electronic circuitry receiving and processing the sensing signal from the magnetic field sensitive element to generate an angle signal indicating the orientation angle of the magnetic field and an angular speed of the shaft.

2. The sensor device of claim 1, wherein the electronic circuitry comprises:

a pair of A/D conversion blocks, wherein a first of the pair of the A/D conversion blocks is to digitalize the first sensing signal component, and a second of the pair of A/D conversion blocks is to digitalize the second sensing signal component;

filtering and self-calibration blocks to filter and calibrate the first and second sensing signal components prior to or after the digitalization;

a memory storing a look-up table or a threshold based algorithm including compensated threshold values to



- generate correct amplitude values correlating to the digitalized first and second sensing signal components to achieve a linearized pulse width and extract the angle signal having correct phase values; and
- a speed pulse generator to receive and process the angle signal to generate pulses indicating the angular speed of the shaft.
3. The sensor device of claim 2, wherein the angular speed of the shaft is generated by selecting a first quantization step during a first operation and a second quantization step smaller than the first quantization step during a second operation with a speed lower than that of the first operation.
4. The sensor device of claim 1, wherein the electronic circuitry comprises:
- a pair of A/D conversion blocks to digitalize the first sensing signal component and the second sensing signal component;
  - filtering and self-calibration blocks to filter and calibrate the digitalized first and second sensing signal components;
  - a processor to receive the digitalized first and second sensing signal components and perform a CORDIC based method to calculate the angle signal indicating the orientation angle of the magnetic field; and
  - a speed pulse generator to receive and process the angle signal to generate pulses indicating the angular speed of the shaft.
5. The sensor device of claim 4, wherein the angular speed of the shaft is generated by using a first CORDIC resolution during a first operation and a second CORDIC resolution greater than the first CORDIC resolution during a second operation with a speed lower than that of the first operation.
6. The sensor device of claim 1, wherein the the electronic circuitry comprises a dynamic controller operating under different process methods based on the angular speed of the shaft.
7. The sensor device of claim 6,
- wherein the dynamic controller is to operate in a first process method when the angular speed of the shaft is greater than a pre-determined threshold value, when in the first process method the dynamic controller is to calculate the angle signal based on a threshold based algorithm.
8. The sensor device of claim 7,
- wherein the dynamic controller is to operate in a second process method and process the sensing signal using a CORDIC based method to calculate the angle signal when the angular speed decreases to a value smaller than or equal to the predetermined threshold value.
9. The sensor device of claim 8,
- wherein the threshold based algorithm and the CORDIC based method are concurrently used to get a pair of rotation angles which are compared to yield a comparison result, wherein the comparison result is evaluated to determine reliability of the rotation angles.
10. The sensor device of claim 1, wherein the electronic circuitry comprises:
- a mode selector for selecting different operating modes, including outputting one or more of speed pulse signals, absolute angle information, direction information, and acceleration information based on the angle signal.
11. The sensor device of claim 1, wherein the electronic circuitry is integrated in a chip attached to the magnetic field sensitive element.
12. A system, comprising:
- a rotatable shaft;
  - a magnet positioned on an end face of the shaft;
  - a magnetic field sensitive element positioned in a magnetic field of the magnet, the magnetic field sensitive element sensing an orientation angle of the magnetic field in a range between 0° and 360° and generating a sensing signal; and
  - electronic circuitry receiving and processing the sensing signal from the magnetic field sensitive element to generate an angle signal indicating the orientation angle of the magnetic field by selecting a process method depending on an angle change rate, an angular speed of the shaft, or a safety function.
13. The system of claim 12,
- wherein the electronic circuitry is to process the sensing signal using a threshold based algorithm including compensated threshold values to generate correct amplitude values correlating to the sensing signal to calculate the angle signal when the angular speed of the shaft has a first relationship with a pre-determined threshold value.
14. The system of claim 13,
- wherein the electronic circuitry is to process the sensing signal using a CORDIC based method to calculate the angle signal when the angular speed has a second relationship with the pre-determined threshold value different from the first relationship.
15. The system of claim 14,
- wherein the electronic circuitry is to determine a first rotation angle and a second rotation angle respectively using the threshold based algorithm and the CORDIC based method, and flag an error based on a comparison of the first rotation angle and the second rotation angle.
16. The system of claim 12, further comprising:
- a memory to store a mapping of pulse edges to orientation angles; and
  - electronic circuitry to generate a signal comprising a pattern of pulses with rising and falling pulse edges, depending on the sensing signal and the stored mapping of pulse edges to orientation angles.
17. The system of claim 12, wherein the electronic circuitry is integrated in a chip attached to the magnetic field sensitive element.
18. An angular sensing device, comprising:
- a magnet positioned on an end face of a shaft;
  - a magnetic field sensitive element positioned in a magnetic field of the magnet, the magnetic field sensitive element generating a sensing signal; and
  - electronic circuitry determining an angular speed of the shaft, selecting a process method based on the angular speed of the shaft, and processing the sensing signal according to the selected process method to generate an angle signal indicating an orientation angle of the magnetic field.
19. The angular sensing device of claim 18, the electronic circuitry further checking reliability of the angle signal, the step of checking comparing a first angle signal determined using a threshold based algorithm and a second angle signal determined using a CORDIC based method.
20. The angular sensing device of claim 18,
- wherein the sensing signal is processed using a threshold based algorithm including compensated threshold values to generate correct amplitude values correlating to

first and second sensing signal components of the sensing signal to extract the angle signal when the angular speed of the shaft is greater than a pre-determined threshold value;  
wherein the sensing signal is processed using a CORDIC based method to calculate the angle signal when the angular speed is smaller than the pre-determined threshold value.

\* \* \* \* \*