



(19) **United States**

(12) **Patent Application Publication**  
Derderian et al.

(10) **Pub. No.: US 2006/0046332 A1**

(43) **Pub. Date: Mar. 2, 2006**

(54) **MICROELECTRONIC IMAGING UNITS AND METHODS OF MANUFACTURING MICROELECTRONIC IMAGING UNITS**

(52) **U.S. Cl. .... 438/28**

(76) **Inventors: James M. Derderian, Boise, ID (US); Bret K. Street, Meridian, ID (US); Eric T. Mueller, Boise, ID (US)**

(57) **ABSTRACT**

Correspondence Address:  
**PERKINS COIE LLP**  
**PATENT-SEA**  
**P.O. BOX 1247**  
**SEATTLE, WA 98111-1247 (US)**

Methods for manufacturing microelectronic imaging units and microelectronic imaging units that are formed using such methods are disclosed herein. In one embodiment, a method includes providing a plurality of imaging dies on a microfeature workpiece. The individual imaging dies include an image sensor, an integrated circuit operably coupled to the image sensor, and a plurality of external contacts operably coupled to the integrated circuit. The method further includes attaching a plurality of covers to corresponding imaging dies, cutting the microfeature workpiece to singulate the imaging dies, and coupling the singulated dies to a support member. The covers can be attached to the imaging dies before or after the workpiece is cut.

(21) **Appl. No.: 10/927,550**

(22) **Filed: Aug. 26, 2004**

**Publication Classification**

(51) **Int. Cl. H01L 21/00 (2006.01)**

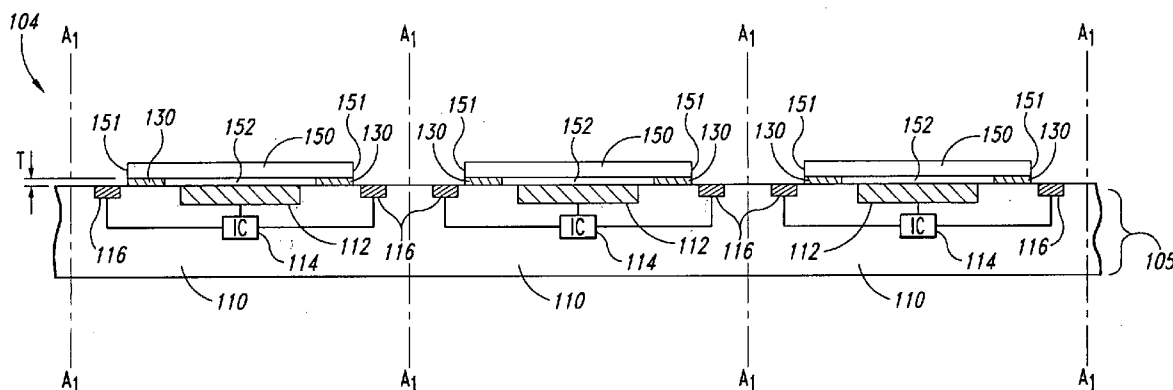

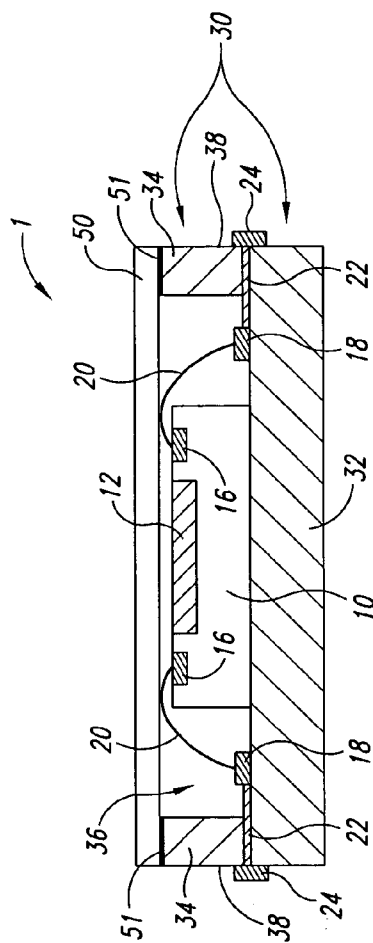

**Fig. 1**  
(Prior Art)

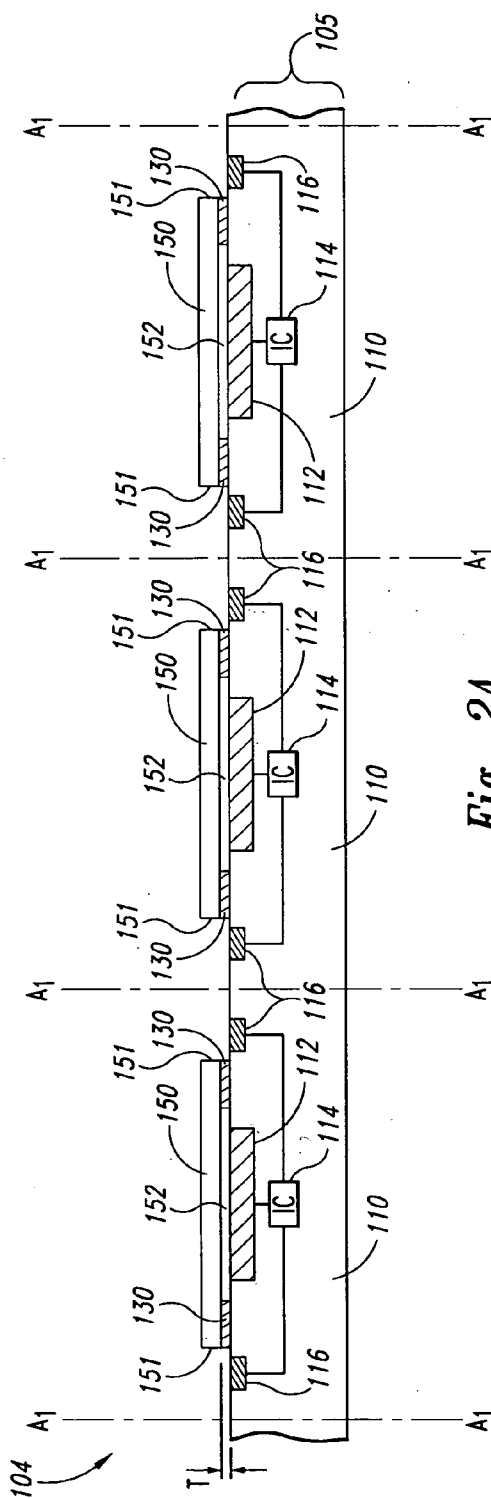

**Fig. 2A**

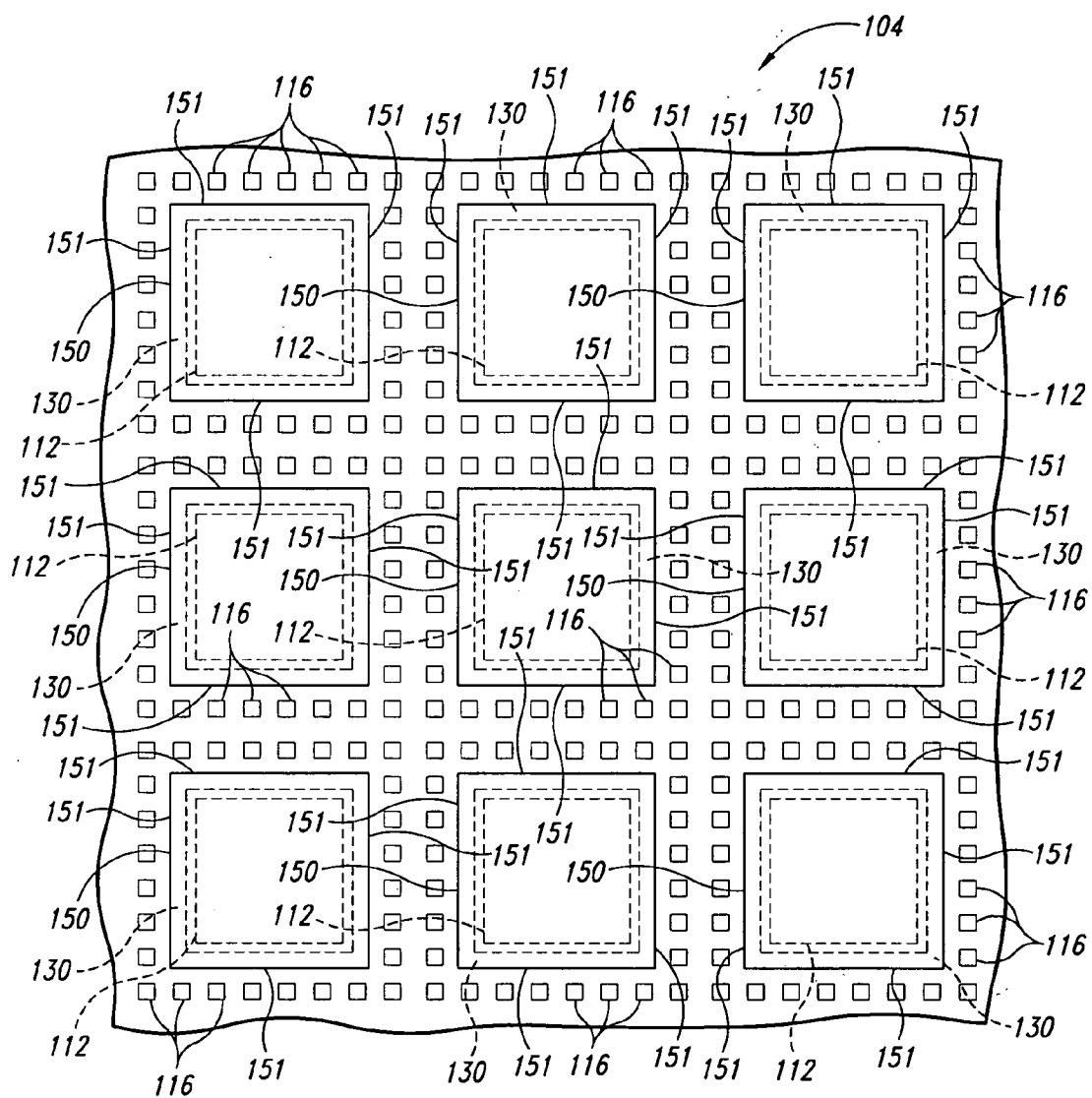

Fig. 2B

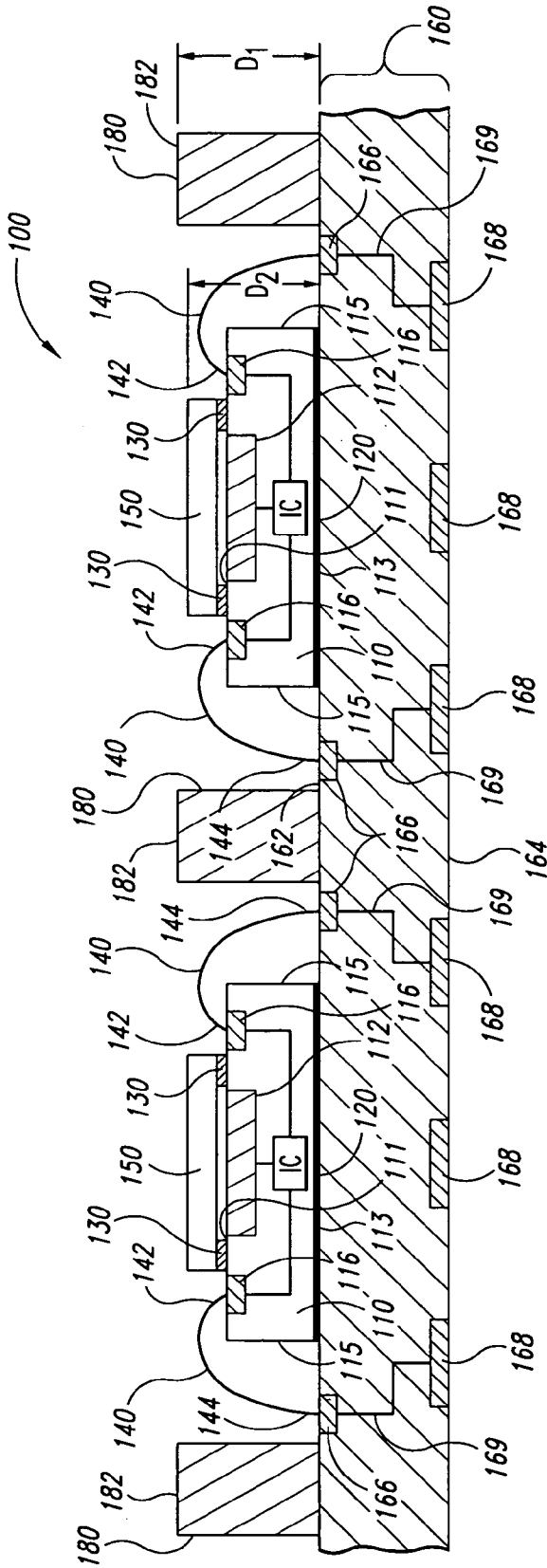

Fig. 3A

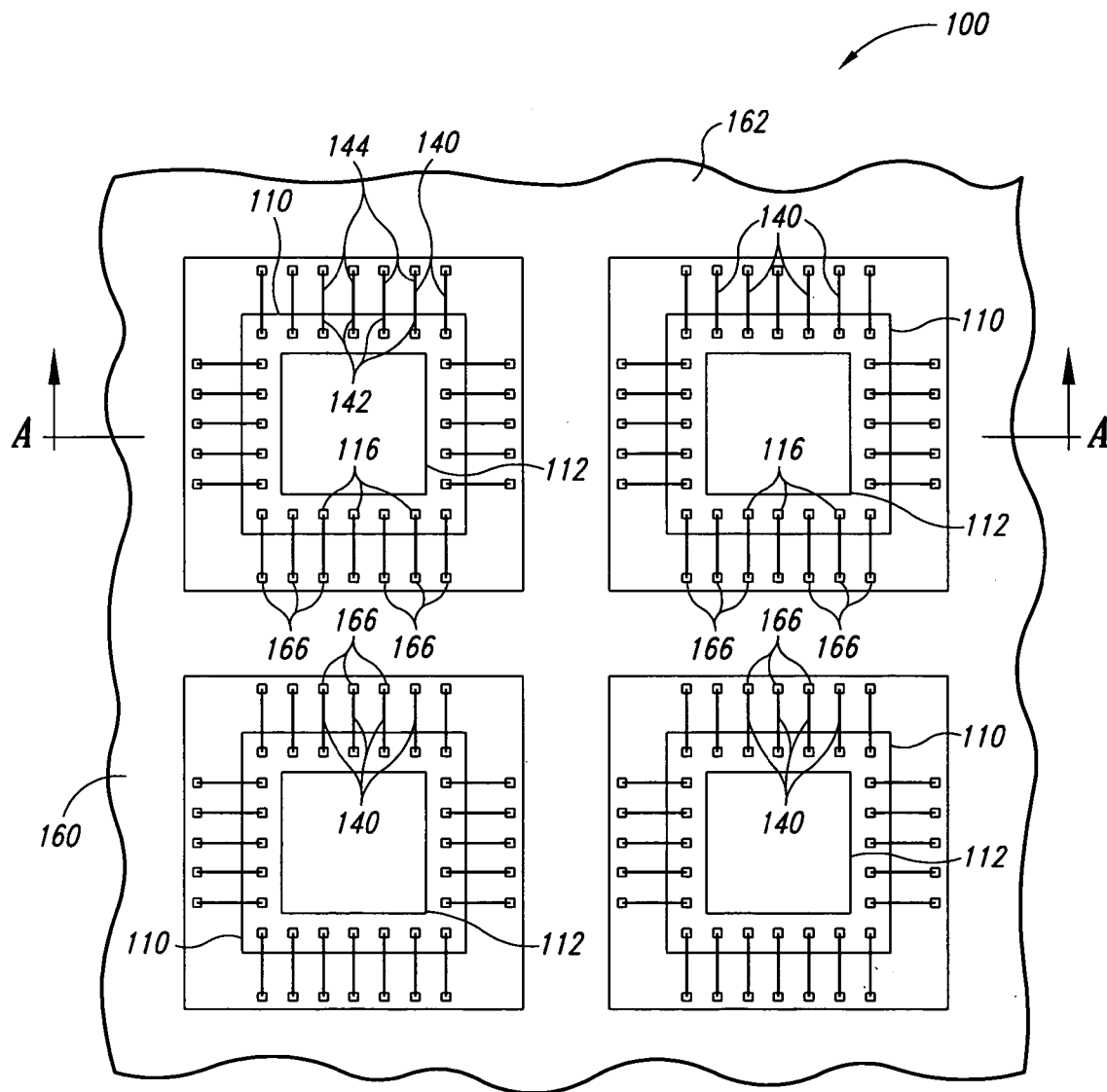

Fig. 3B

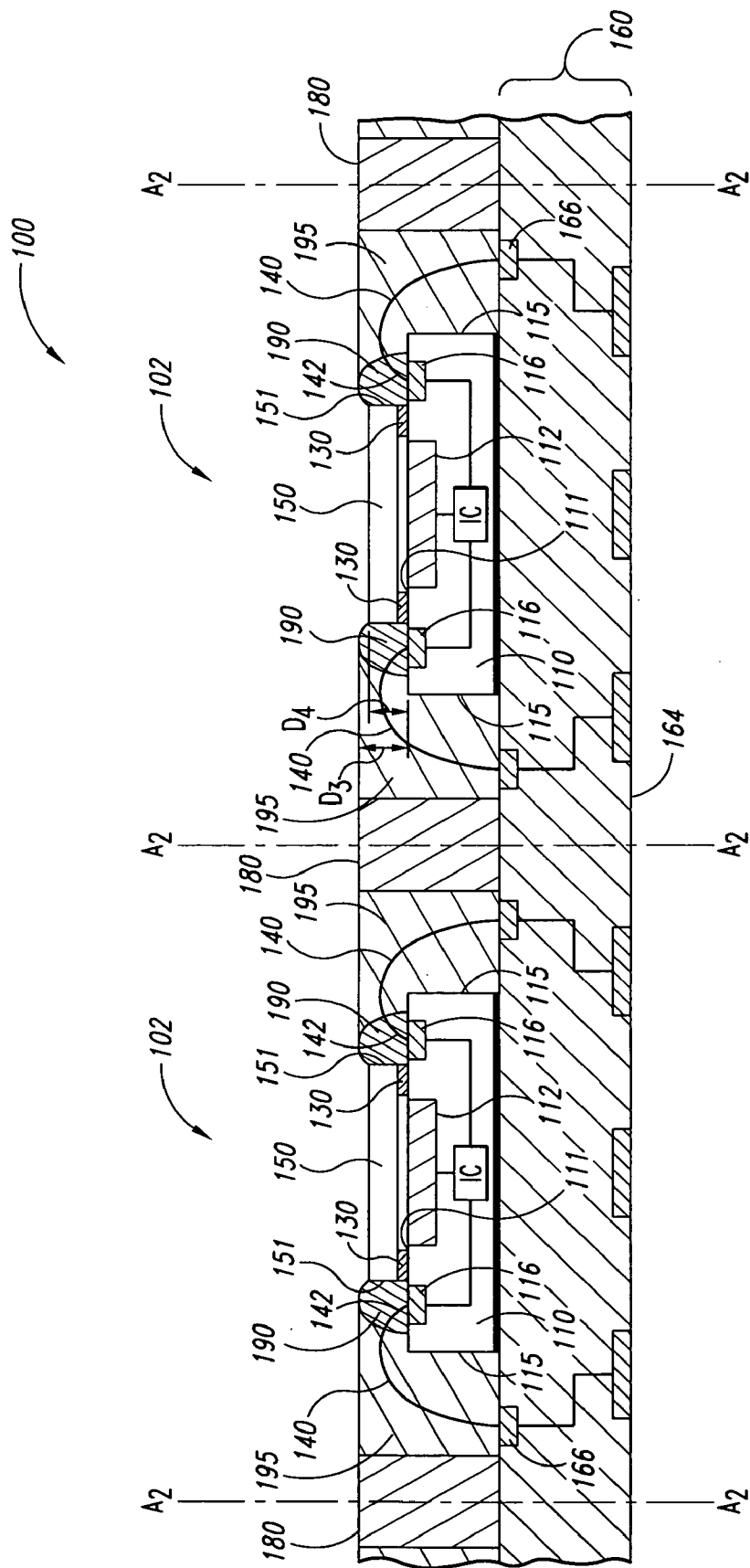

Fig. 4



**MICROELECTRONIC IMAGING UNITS AND METHODS OF MANUFACTURING MICROELECTRONIC IMAGING UNITS**

**TECHNICAL FIELD**

[0001] The present invention is related to microelectronic imaging units having solid-state image sensors and methods for manufacturing such imaging units.

**BACKGROUND**

[0002] Microelectronic imagers are used in digital cameras, wireless devices with picture capabilities, and many other applications. Cell phones and Personal Digital Assistants (PDAs), for example, are incorporating microelectronic imagers for capturing and sending pictures. The growth rate of microelectronic imagers has been steadily increasing as they become smaller and produce better images with higher pixel counts.

[0003] Microelectronic imagers include image sensors that use Charged Coupled Device (CCD) systems, Complementary Metal-Oxide Semiconductor (CMOS) systems, or other solid-state systems. CCD image sensors have been widely used in digital cameras and other applications. CMOS image sensors are also quickly becoming very popular because they are expected to have low production costs, high yields, and small sizes. CMOS image sensors can provide these advantages because they are manufactured using technology and equipment developed for fabricating semiconductor devices. CMOS image sensors, as well as CCD image sensors, are accordingly "packaged" to protect their delicate components and to provide external electrical contacts.

[0004] FIG. 1 is a schematic side cross-sectional view of a conventional microelectronic imaging unit 1 including an imaging die 10, a chip carrier 30 carrying the die 10, and a cover 50 attached to the carrier 30 and positioned over the die 10. The imaging die 10 includes an image sensor 12 and a plurality of bond-pads 16 operably coupled to the image sensor 12. The chip carrier 30 has a base 32, sidewalls 34 projecting from the base 32, and a recess 36 defined by the base 32 and sidewalls 34. The die 10 is accordingly sized to be received within the recess 36 and attached to the base 32. The chip carrier 30 further includes an array of terminals 18 on the base 32, an array of contacts 24 on an external surface 38, and a plurality of traces 22 electrically connecting the terminals 18 to corresponding external contacts 24. The terminals 18 are positioned between the die 10 and the sidewalls 34 so that wire-bonds 20 can electrically couple the terminals 18 to corresponding bond-pads 16 on the die 10.

[0005] One problem with the microelectronic imaging unit 1 illustrated in FIG. 1 is that the die 10 must be sized and configured to fit within the recess 36 of the chip carrier 30. Dies having different shapes and/or sizes accordingly require chip carriers configured to house those specific types of dies. As such, manufacturing imaging units with dies having different sizes requires fabricating various configurations of chip carriers and significantly retooling the manufacturing process.

[0006] Another problem with conventional microelectronic imaging units is that they have relatively large foot-

prints and occupy a significant amount of vertical space (i.e., high profiles). For example, the footprint of the imaging unit 1 in FIG. 1 is the surface area of the base 32 of the chip carrier 30, which is significantly larger than the surface area of the die 10. Accordingly, the footprint and vertical profile of conventional microelectronic imaging units can be a limiting factor in the design and marketability of picture cell phones or PDAs because these devices are continually being made smaller in order to be more portable. Therefore, there is a need to provide microelectronic imaging units with smaller footprints and lower vertical profiles.

**BRIEF DESCRIPTION OF THE DRAWINGS**

[0007] FIG. 1 is a schematic side cross-sectional view of a conventional microelectronic imaging unit in accordance with the prior art.

[0008] FIGS. 2A-4 illustrate stages in one embodiment of a method for manufacturing a plurality of microelectronic imaging units in accordance with the invention.

[0009] FIG. 2A is a schematic side cross-sectional view of a microfeature workpiece having a substrate and a plurality of microelectronic imaging dies formed in and/or on the substrate.

[0010] FIG. 2B is a top plan view of the workpiece illustrated in FIG. 2A.

[0011] FIG. 3A is a schematic side cross-sectional view of an assembly including singulated microelectronic imaging dies arranged in an array on a support member.

[0012] FIG. 3B is a top plan view of the assembly illustrated in FIG. 3A.

[0013] FIG. 4 is a schematic side cross-sectional view of the assembly after (a) forming a plurality of dams on corresponding imaging dies and (b) depositing a fill material onto the support member between a barrier and the imaging dies.

[0014] FIG. 5 is a schematic side cross-sectional view of an assembly including a plurality of microelectronic imaging units in accordance with another embodiment of the invention.

[0015] FIG. 6 is a schematic side cross-sectional view of an imaging unit in accordance with another embodiment of the invention.

**DETAILED DESCRIPTION**

**A. Overview**

[0016] The following disclosure describes several embodiments of methods for manufacturing microelectronic imaging units and microelectronic imaging units that are formed using such methods. One aspect of the invention is directed toward methods for manufacturing a plurality of imaging units. An embodiment of one such method includes providing a plurality of imaging dies on a microfeature workpiece. The individual imaging dies include an image sensor, an integrated circuit operably coupled to the image sensor, and a plurality of external contacts operably coupled to the integrated circuit. The method further includes attaching a plurality of covers to corresponding imaging dies, cutting the microfeature workpiece to singulate the imaging dies, and coupling the singulated dies to a support member.



The microfeature workpiece can be cut before or after the covers are attached to the imaging dies. The covers can be attached to the imaging dies with an adhesive that is disposed outboard the image sensor and defines a cell between the cover and the die. Alternatively, the adhesive can be disposed between the cover and the image sensor.

[0017] In another embodiment, a method includes coupling a plurality of singulated imaging dies to a support member, placing a plurality of covers on corresponding imaging dies with the covers disposed inboard of the external contacts of the imaging dies, electrically connecting the external contacts to corresponding terminals on the support member, and forming a plurality of dams on corresponding dies. The individual dams are arranged to define a perimeter around the corresponding covers. The method may further include forming a barrier on the support member between adjacent dies and depositing a fill material onto the support member between the barrier and the imaging dies. The fill material can at least partially encapsulate the imaging dies.

[0018] Another aspect of the invention is directed toward a plurality of microelectronic imaging units. In one embodiment, an assembly of imaging units includes a support member and a plurality of imaging dies carried by the support member. The support member includes a plurality of terminal arrays, and the individual imaging dies include a first side, a second side attached to the support member, an image sensor, an integrated circuit operably coupled to the image sensor, and a plurality of external contacts operably coupled to the integrated circuit. The assembly further includes a plurality of covers attached to the first side of corresponding dies, a plurality of wire-bonds electrically connecting the external contacts to corresponding terminals, and a barrier on the support member between adjacent imaging dies. The assembly may further include a plurality of dams on corresponding dies and a fill material on the support member between the barrier and the imaging dies. The individual dams form a perimeter around the corresponding cover and inhibit the fill material from flowing onto the cover.

[0019] Another aspect of the invention is directed toward a microelectronic imaging unit. In one embodiment, an imaging unit includes a support member having a base, a plurality of sidewalls projecting from the base, a recess defined by the sidewalls and the base, and a plurality of terminals in the base and/or sidewalls. The imaging unit further includes an imaging die received in the recess and attached to the base of the support member. The imaging die has an image sensor, an integrated circuit operably coupled to the image sensor, and a plurality of external contacts operably coupled to the integrated circuit. The imaging unit further includes a cover attached to the imaging die, a plurality of wire-bonds electrically connecting the external contacts to corresponding terminals, and a fill material in the recess between the imaging die and the sidewalls.

[0020] Specific details of several embodiments of the invention are described below with reference to CMOS imaging units to provide a thorough understanding of these embodiments, but other embodiments can use CCD imaging units or other types of solid-state imaging devices. Several details describing structures or processes that are well known and often associated with other types of microelectronic devices are not set forth in the following description

for purposes of brevity. Moreover, although the following disclosure sets forth several embodiments of different aspects of the invention, several other embodiments of the invention can have different configurations or different components than those described in this section. As such, it should be understood that the invention may have other embodiments with additional elements or without several of the elements described below with reference to **FIGS. 2A-6**.

#### B. Embodiments of Methods for Manufacturing Microelectronic Imaging Units

[0021] **FIGS. 2A-4** illustrate stages of a method for manufacturing a plurality of microelectronic imaging units in accordance with one embodiment of the invention. **FIG. 2A**, for example, is a schematic side cross-sectional view of a microfeature workpiece **104** having a substrate **105** and a plurality of microelectronic imaging dies **110** (only three are shown) formed in and/or on the substrate **105**. The individual imaging dies **110** include an image sensor **112**, an integrated circuit **114** (shown schematically) operably coupled to the image sensor **112**, and a plurality of external contacts **116** (e.g., bond-pads) operably coupled to the integrated circuit **114**. The image sensors **112** can be CMOS devices or CCD image sensors for capturing pictures or other images in the visible spectrum. The image sensors **112** may also detect radiation in other spectrums (e.g., IR or UV ranges).

[0022] **FIG. 2B** is a top plan view of the microfeature workpiece **104** illustrated in **FIG. 2A**. Referring to both **FIGS. 2A and 2B**, after forming the imaging dies **110**, a plurality of covers **150** are attached to corresponding dies **110** and positioned over the image sensors **112**. The covers **150** can be glass, quartz, or another suitable material that is transmissive to the desired spectrum of radiation. The covers **150**, for example, can further include one or more anti-reflective films and/or filters. The covers **150** include a plurality of ends **151**, and although in the illustrated embodiment, the ends **151** are inboard the external contacts **116**, in other embodiments, the ends **151** may not be inboard the external contacts **116**. The ends **151** of the covers **150** are inboard the external contacts **116** in the sense that they are within the perimeters defined by the sets of external contacts **116**.

[0023] The covers **150** are attached to the imaging dies **110** with an adhesive **130**. The adhesive **130** has a thickness **T** (**FIG. 2A**) and spaces the covers **150** apart from the imaging dies **110** by a precise, predetermined distance. In the illustrated embodiment, the discrete portions of the adhesive **130** are disposed between a perimeter portion of the individual covers **150** and the dies **110**. As such, the discrete portions of the adhesive **130** are positioned outboard the corresponding image sensor **112** and inboard the external contacts **116** (e.g., between the image sensor **112** and the external contacts **116**). In other embodiments, such as those described below with reference to **FIG. 5**, the adhesive **130** may also be disposed between the covers **150** and the image sensors **112**.

[0024] In the illustrated embodiment, the individual portions of adhesive **130** form a perimeter around the corresponding image sensor **112** and define a cell **152** (**FIG. 2A**) between the cover **150** and the image sensor **112**. The cells **152** can be filled with gas, such as air, underfill material, or another suitable material. In other embodiments, the adhe-

sive **130** may not form perimeters around the image sensors **112**. For example, several discrete volumes of the adhesive **130** can be placed around each image sensor **112** to couple the corresponding cover **150** to the die **110**. The discrete volumes of the adhesive **130** can be disposed proximate to the corners of the covers **150** or positioned in other arrangements.

[0025] The adhesive **130** can be an epoxy, acrylic, or other suitable material that is applied to the covers **150** and/or the imaging dies **110** by stencil printing, screen printing, dispensing, photolithography, or other suitable techniques. In embodiments in which the adhesive **130** is a UV- or thermally-curable material, the workpiece **104** can be heated to at least partially cure (i.e., B-stage) the adhesive **130** after attaching the covers **150** to the substrate **105** (FIG. 2A). After curing, the workpiece **104** can be cut along lines  $A_1$ - $A_1$  (FIG. 2A) to singulate the individual dies **110**.

[0026] FIG. 3A is a schematic side cross-sectional view of an assembly **100** including the singulated microelectronic imaging dies **110** (only two are shown) arranged in an array on a support member **160**. The individual singulated dies **110** include a first side **111**, a second side **113** opposite the first side **111**, and a plurality of ends **115** extending from the first side **111** to the second side **113**. The second side **113** of the imaging dies **110** is attached to the support member **160** with an adhesive **120**, such as an adhesive film, epoxy, or other suitable material. In several embodiments, the covers **150** can be attached to the imaging dies **110** after the dies **110** are coupled to the support member **160**.

[0027] The support member **160** can be a lead frame or a substrate, such as a printed circuit board, for carrying the imaging dies **110**. In the illustrated embodiment, the support member **160** includes a first side **162** having a plurality of terminals **166** and a second side **164** having a plurality of pads **168**. The terminals **166** can be arranged in arrays for attachment to corresponding external contacts **116** of the dies **110**, and the pads **168** can be arranged in arrays for attachment to a plurality of conductive couplers (e.g., solder balls). The support member **160** further includes a plurality of conductive traces **169** electrically coupling the terminals **166** to corresponding pads **168**.

[0028] FIG. 3B is a top plan view of the assembly **100** illustrated in FIG. 3A. Referring to both FIGS. 3A and 3B, the assembly **100** further includes a plurality of wire-bonds **140** electrically coupling the external contacts **116** of the imaging dies **110** to corresponding terminals **166** on the support member **160**. The individual wire-bonds **140** include a proximal portion **142** attached to one of the contacts **116** and a distal portion **144** attached to the corresponding terminal **166**. In other embodiments, the external contacts **116** can be electrically connected to terminals on a support member by conductive through-wafer interconnects. Through-wafer interconnects are described in U.S. patent application Ser. No. 10/713,878 filed on Nov. 13, 2003, which is hereby incorporated by reference.

[0029] The illustrated assembly **100** further includes a barrier **180** formed on the support member **160** between adjacent imaging dies **110**. The barrier **180** forms the outer sidewalls of the individual imaging units, as described in greater detail below. Although in the illustrated embodiment, the barrier **180** is disposed outboard the wire-bonds **140** and the terminals **166**, in other embodiments, the barrier **180**

may cover or partially encapsulate the wire-bonds **140** and/or the terminals **166**. The barrier **180** can be formed by transfer molding, stereolithography, stencil printing, screen printing, or other suitable processes. The barrier **180** projects a first distance  $D_1$  from the support member **160**, and the die **110** and cover **150** project a second distance  $D_2$  from the support member **160**. In the illustrated embodiment, the first distance  $D_1$  is greater than the second distance  $D_2$ , and the barrier **180** has a generally flat top surface **182** to which a camera module or other optical device can be mounted. In other embodiments, the first distance  $D_1$  can be equal to or less than the second distance  $D_2$  and/or the top surface **182** may not be generally flat. Alternatively, in several embodiments such as those described below with reference to FIG. 5, the assembly **100** may not include the barrier **180**.

[0030] FIG. 4 is a schematic side cross-sectional view of the assembly **100** after (a) forming a plurality of dams **190** on corresponding imaging dies **110** and (b) depositing a fill material **195** onto the support member **160** between the barrier **180** and the imaging dies **110**. The illustrated dams **190** are formed on the first side **111** of the imaging dies **110** outboard the covers **150** and inhibit the fill material **195** from flowing onto the covers **150** and obstructing the passage of radiation through the covers **150**. As such, the dams **190** project a first distance  $D_3$  from the dies **110**, and the adhesive **130** and covers **150** project a second distance  $D_4$  from the dies **110**. The first distance  $D_3$  can be greater than or equal to the second distance  $D_4$ . Moreover, the dams **190** may also encapsulate the ends **151** of the covers **150** and/or the proximal portion **142** of the individual wire-bonds **140**. The dams **190** can be an epoxy, polyimide, acrylic, or other suitable material for (a) enhancing the integrity of the joint between the individual covers **150** and the imaging dies **110**, and (b) protecting the image sensors **112** from moisture, chemicals, and other contaminants. In other embodiments, the dams **190** may not encapsulate the ends **151** of the covers **150** and/or the proximal portion **142** of the wire-bonds **140**. Alternatively, the assembly **100** may not include the dams **190**, but rather the fill material **195** can contact the ends **151** of the covers **150** and the proximal portion **142** of the wire-bonds **140**.

[0031] After forming the dams **190**, the fill material **195** is dispensed onto the support member **160** and fills the recess between the imaging dies **110** and the barrier **180**. The fill material **195** can be an epoxy mold compound or other suitable material to at least partially encapsulate the imaging dies **110**, the wire-bonds **140**, and the dams **190**. As such, the fill material **195** (a) increases the robustness of the assembly **100**, (b) supports the wire-bonds **140**, and (c) protects the image sensors **112** from moisture, chemicals, and other contaminants. After depositing the fill material **195**, the assembly **100** can be heated to at least partially cure (i.e., B-stage) the fill material **195**, the dam **190**, and/or the adhesive **130**. After curing, the assembly **100** can be cut along lines  $A_2$ - $A_2$  to singulate individual imaging units **102**.

[0032] One feature of the imaging units **102** illustrated in FIG. 4 is that the covers **150** are attached to the imaging dies **110** and positioned inboard the external contacts **116**. An advantage of this feature is that the vertical profile or height of the imaging units **102** is reduced. For example, the vertical profile of the imaging units **102** is the distance between the top of the dam **190** and the second side **164** of the support member **160**. By contrast, in prior art devices,

such as the imaging unit **1** illustrated in **FIG. 1**, the cover **50** is attached to sidewalls **34** and sufficiently spaced apart from the image sensor **12** so that the wire-bonds **20** can extend from the bond-pads **16** to the terminals **18**. Another advantage of this feature is that the material cost of the covers **150** is reduced because the covers **150** are smaller than conventional covers, such as the cover **50** illustrated in **FIG. 1**.

[0033] Another feature of the imaging units **102** illustrated in **FIG. 4** is that the barrier **180** has a predetermined height **D**, and a generally flat top surface **182**. An advantage of this feature is that camera modules and other devices can be mounted on the surface **182** and positioned at a precise distance over the image sensors **112**. In prior art devices, camera modules are typically mounted on a stack of several components, each of which introduces greater variance in the height of the stack. For example, in **FIG. 1**, a camera module can be coupled to the cover **50**, which is attached to an adhesive **51**, which is coupled to the sidewall **34**.

[0034] One feature of the method for manufacturing imaging units **102** illustrated in **FIGS. 2A-4** is that the support member **160** can carry imaging dies **110** with different sizes and/or configurations. An advantage of this feature is that the method can be easily adapted to handle various configurations of imaging dies without significant changes to the fabrication process. Prior art methods, such as the method required to form the imaging unit **1** described above with reference to **FIG. 1**, may require significant retooling because the chip carriers **30** can only carry imaging dies **10** with a certain shape and size.

[0035] Another advantage of the method for manufacturing imaging units **102** illustrated in **FIGS. 2A-4** is that the method is expected to significantly enhance the efficiency of the manufacturing process because a plurality of imaging units **102** can be fabricated simultaneously using highly accurate and efficient processes developed for packaging and manufacturing semiconductor devices. This method of manufacturing imaging units **102** is also expected to enhance the quality and performance of the imaging units **102** because the semiconductor fabrication processes can reliably produce and assemble the various components with a high degree of precision. As such, several embodiments of the method are expected to significantly reduce the cost for assembling microelectronic imaging units **102**, increase the performance of the imaging units **102**, and produce higher quality imaging units **102**.

#### C. Additional Embodiments of Methods for Manufacturing Microelectronic Imaging Units

[0036] **FIG. 5** is a schematic side cross-sectional view of an assembly **200** including a plurality of microelectronic imaging units **202** in accordance with another embodiment of the invention. The microelectronic imaging units **202** are generally similar to the microelectronic imaging units **102** described above with reference to **FIG. 4**. The imaging units **202** shown in **FIG. 5**, however, do not include a barrier between adjacent dies **110**. Rather, the fill material **195** fills the space between the adjacent imaging dies **110** and forms the sidewall of the imaging units **202** after the units **202** are singulated.

[0037] One feature of the imaging units **202** illustrated in **FIG. 5** is that the wire-bonds **140** are encapsulated by the fill material **195** that forms the sidewalls of the individual units

**202**. An advantage of this feature is that the footprint of the individual imaging units **202** is smaller than the footprint of conventional imaging units. The reduced footprint of the imaging units **202** is particularly advantageous for picture cell phones, PDAs, or other applications where space is limited. In prior art devices, such as the imaging unit **1** illustrated in **FIG. 1**, the sidewalls **34** are outboard the terminals **18** and the wire-bonds **20**, which increases the footprint of the imaging unit **1**.

[0038] The illustrated assembly **200** further includes discrete portions of an adhesive **230** attaching the covers **150** to corresponding imaging dies **110**. The individual portions of the adhesive **230** are disposed between the covers **150** and the first side **111** of the imaging dies **110** such that the adhesive **230** extends across the image sensors **112**. The adhesive **230** can be an optical grade material with a high transparency to eliminate or reduce light scattering and/or the loss of images. In applications in which the image sensors **112** have pixels with a smaller size, the adhesive **230** can have a higher refractive index to assist in focusing the light for the pixels.

[0039] One feature of the imaging units **202** illustrated in **FIG. 5** is that the adhesive **230** can be a material that is dimensionally stable over a wide range of temperatures. An advantage of this feature is that the distance between the covers **150** and the corresponding image sensors **112** remains generally consistent, even if the imaging units **202** operate in an environment that experiences significant changes in ambient temperature. If the temperature change were to cause the medium between the cover **150** and the image sensor **112** to expand or contract, the associated change in the distance between the cover **150** and the image sensor **112** could skew the images and reduce the life of the imaging unit **202** due to fatigue.

[0040] **FIG. 6** is a schematic side cross-sectional view of an imaging unit **302** in accordance with another embodiment of the invention. The microelectronic imaging unit **302** is generally similar to the imaging unit **102** described above with reference to **FIG. 4**. The imaging unit **302** shown in **FIG. 6**, however, includes a support member **360** having a base **361**, a plurality of sidewalls **363** projecting from the base **361**, and a recess **365** defined by the base **361** and the sidewalls **363**. The base **361** and sidewalls **363** can be a preformed, unitary member sized to receive the imaging die **110**. As such, the imaging die **110** is received in the recess **365** and attached to the base **361**. Another aspect of the illustrated imaging unit **302** is that the unit **302** does not include an adhesive between the cover **150** and the die **110** but rather the dam **190** secures the cover **150** to the imaging die **110**. In other embodiments, however, the cover **150** can be attached to the imaging die **110** with an adhesive.

[0041] From the foregoing, it will be appreciated that specific embodiments of the invention have been described herein for purposes of illustration, but that various modifications may be made without deviating from the spirit and scope of the invention. For example, the microelectronic imaging units can have any combination of the features described above. Accordingly, the invention is not limited except as by the appended claims.

1. A method of manufacturing a plurality of imaging units, the method comprising:

providing a plurality of imaging dies on a microfeature workpiece, the individual imaging dies including an image sensor, an integrated circuit operably coupled to the image sensor, and a plurality of external contacts operably coupled to the integrated circuit;

attaching a plurality of covers to corresponding imaging dies with the covers positioned over the image sensors;

cutting the microfeature workpiece to singulate the imaging dies; and

coupling the singulated dies to a single support member having terminals for electrical connection to the external contacts and pads electrically coupled to the terminals.

**2.** The method of claim 1, further comprising:

electrically connecting the external contacts of the imaging dies to corresponding terminals on the support member;

building a barrier between adjacent dies;

forming a plurality of dams on corresponding dies after attaching the covers, the individual dams defining a perimeter around the associated cover; and

depositing a fill material onto the support member between the barrier and the imaging dies to at least partially encapsulate the imaging dies.

**3.** The method of claim 1 wherein cutting the microfeature workpiece occurs after attaching the covers to the imaging dies.

**4.** The method of claim 1 wherein attaching the covers to the imaging dies comprises:

depositing discrete portions of an adhesive onto the covers and/or the imaging dies; and

placing the covers on the corresponding imaging dies such that the individual portions of the adhesive are disposed outboard the image sensor and define a cell between the cover and the die.

**5.** The method of claim 1 wherein attaching the covers to the imaging dies comprises:

depositing discrete portions of an adhesive onto the covers and/or the imaging dies; and

placing the covers on the corresponding imaging dies such that the individual portions of the adhesive are disposed between the associated image sensor and cover.

**6.** The method of claim 1 wherein attaching the covers to the imaging dies comprises coupling the covers to the imaging dies with a UV-curable adhesive.

**7.** The method of claim 1, further comprising forming a plurality of dams on corresponding dies after attaching the covers to the dies, the individual dams defining a perimeter around the associated cover.

**8.** The method of claim 1, further comprising forming a barrier on the support member between adjacent dies.

**9.** The method of claim 1, further comprising depositing a fill material onto the support member between adjacent imaging dies to at least partially encapsulate the imaging dies.

**10.** The method of claim 1 wherein attaching the covers to the imaging dies comprises coupling the covers to the

imaging dies such that the individual covers are disposed inboard the external contacts.

**11.** A method of manufacturing a plurality of imaging units, the method comprising:

coupling a plurality of singulated imaging dies to a support member, the individual imaging dies comprising an image sensor, an integrated circuit operably coupled to the image sensor, and a plurality of external contacts operably coupled to the integrated circuit;

placing a plurality of covers on corresponding imaging dies with the covers disposed inboard the external contacts;

electrically connecting the external contacts of the imaging dies to corresponding terminals on the support member; and

forming a plurality of dams on corresponding dies after placing the covers on the imaging dies, the individual dams defining a perimeter around an associated cover.

**12.** The method of claim 11 wherein placing the covers on the corresponding imaging dies occurs before coupling the dies to the support member.

**13.** The method of claim 11 wherein:

electrically connecting the external contacts comprises wire-bonding the external contacts to the terminals with a proximal end of the individual wire-bonds attached to the contacts; and

forming the dams comprises encapsulating the proximal end of the individual wire-bonds.

**14.** The method of claim 11 wherein the covers include a plurality of ends, and wherein forming the dams comprises encapsulating the ends of the individual covers.

**15.** The method of claim 11 wherein placing the covers on the imaging dies comprises:

depositing discrete portions of an adhesive onto the covers and/or the imaging dies; and

attaching the covers to the corresponding imaging dies such that the individual portions of the adhesive are disposed outboard the image sensor and define a cell between the cover and the die.

**16.** The method of claim 11 wherein placing the covers on the imaging dies comprises:

depositing discrete portions of an adhesive onto the covers and/or the imaging dies; and

attaching the covers to the corresponding imaging dies such that the individual portions of the adhesive are disposed between the associated image sensor and cover.

**17.** The method of claim 11, further comprising depositing a fill material onto the support member between adjacent imaging dies to at least partially encapsulate the imaging dies.

**18.** The method of claim 11, further comprising:

forming a barrier on the support member between adjacent dies; and

depositing a fill material onto the support member between the barrier and the imaging dies.

**19.** A method of manufacturing a plurality of imaging units, the method comprising:

- constructing a plurality of imaging dies on a microfeature workpiece, the individual imaging dies including an image sensor, an integrated circuit operably coupled to the image sensor, and a plurality of external contacts operably coupled to the integrated circuit;
- coupling a plurality of covers to corresponding imaging dies with the covers positioned over the image sensors;
- cutting the microfeature workpiece to separate the imaging dies after coupling the covers to the imaging dies;
- attaching the singulated dies to a support member;
- wire-bonding the external contacts of the imaging dies to corresponding terminals on the support member; and
- depositing a fill material onto the support member between adjacent imaging dies to at least partially encapsulate the imaging dies.
- 20.** The method of claim 19 wherein depositing the fill material comprises encapsulating at least a portion of the individual wire-bonds.
- 21.** The method of claim 19 wherein coupling the covers to the imaging dies comprises:
- depositing discrete portions of an adhesive onto the covers and/or the imaging dies; and
- attaching the covers to the corresponding imaging dies such that the individual portions of the adhesive are disposed outboard the image sensor and define a cell between the cover and the die.
- 22.** The method of claim 19, further comprising forming a plurality of dams on corresponding dies after coupling the covers to the dies and before depositing the fill material, the individual dams defining a perimeter around the associated cover.
- 23.** The method of claim 19, further comprising forming a barrier on the support member between adjacent dies before depositing the fill material.
- 24.** A method of manufacturing a plurality of imaging units, the method comprising:
- providing a plurality of imaging dies on a microfeature workpiece, the individual imaging dies including an image sensor, an integrated circuit operably coupled to the image sensor, and a plurality of external contacts operably coupled to the integrated circuit;
- attaching a plurality of covers to corresponding imaging dies with the covers positioned over the image sensors;
- cutting the microfeature workpiece to singulate the imaging dies;
- coupling the singulated dies to a support member;
- electrically connecting the external contacts of the imaging dies to corresponding terminals on the support member;
- building a barrier between adjacent dies after attaching the covers to the dies; and
- forming a plurality of dams on corresponding dies, the individual dams surrounding the associated cover.
- 25.** The method of claim 24 wherein building the barrier comprises constructing the barrier with a generally flat top surface.
- 26.** The method of claim 24 wherein building the barrier comprises constructing the barrier outboard the terminals.
- 27.** The method of claim 24 wherein:
- electrically connecting the external contacts comprises wire-bonding the external contacts to the corresponding terminals; and
- building the barrier comprises constructing the barrier outboard the wire-bonds.
- 28.** The method of claim 24 wherein forming the dams occurs after (a) electrically connecting the external contacts and the terminals and (b) attaching the covers to the imaging dies.
- 29.** The method of claim 24 wherein:
- electrically connecting the external contacts comprises wire-bonding the external contacts to the terminals with a proximal end of the individual wire-bonds attached to the contacts; and
- forming the dams comprises encapsulating the proximal end of the individual wire-bonds.
- 30.** The method of claim 24 wherein the covers include a plurality of ends, and wherein forming the dams comprises encapsulating the ends of the individual covers.
- 31.** The method of claim 24, further comprising depositing a fill material between the barrier and the imaging dies.
- 32.** A method of manufacturing a plurality of imaging dies on a microfeature workpiece, the method comprising:
- constructing a plurality of imaging dies on the microfeature workpiece, the individual imaging dies including an image sensor and a plurality of bond-pads operably coupled to the image sensor; and
- attaching a plurality of covers to corresponding imaging dies on the workpiece with discrete portions of an adhesive, the individual portions of the adhesive being disposed between the associated cover and die and outboard the image sensor.
- 33.** The method of claim 32 wherein attaching the covers to the imaging dies comprises:
- depositing the discrete portions of the adhesive onto the covers and/or the imaging dies; and
- placing the covers on the corresponding imaging dies such that the individual portions of the adhesive define a cell between the cover and the die.
- 34.** The method of claim 32 wherein attaching the covers to the imaging dies comprises coupling the covers to the imaging dies such that the individual covers are inboard the external contacts.
- 35.** A method of manufacturing an imaging unit, the method comprising:
- providing a support member having a base, a plurality of sidewalls projecting from the base, and a recess defined by the sidewalls and the base;
- coupling an imaging die to the base of the support member with the die received within the recess, the imaging die including an image sensor, an integrated circuit operably coupled to the image sensor, and a plurality of external contacts operably coupled to the integrated circuit;
- attaching a cover to the imaging die with the cover positioned over the image sensor;

electrically connecting the external contacts of the imaging die to corresponding terminals on the support member; and

depositing a fill material into the recess of the support member between the imaging die and the sidewalls to at least partially encapsulate the imaging die.

**36.** The method of claim 35 wherein:

electrically connecting the external contacts to the terminals comprises wire-bonding the contacts to the terminals; and

depositing the fill material comprises at least partially encapsulating the individual wire-bonds.

**37.** The method of claim 35 wherein attaching the cover to the imaging die occurs before coupling the imaging die to the support member.

**38.** The method of claim 35, further comprising forming a dam on the imaging die, the dam defining a perimeter around the cover.

**39.** The method of claim 35 wherein attaching the cover comprises coupling the cover such that the cover is inboard the external contacts.

**40.** The method of claim 35 wherein attaching the cover comprises:

depositing an adhesive onto the cover and/or the imaging die; and

placing the cover on the imaging die such that the adhesive is disposed outboard the image sensor and defines a cell between the cover and the die.

**41.** The method of claim 35 wherein attaching the cover comprises:

depositing an adhesive onto the cover and/or the imaging die; and

placing the cover on the imaging die such that the adhesive is disposed between the image sensor and the cover.

**42-82.** (canceled)

\* \* \* \* \*