

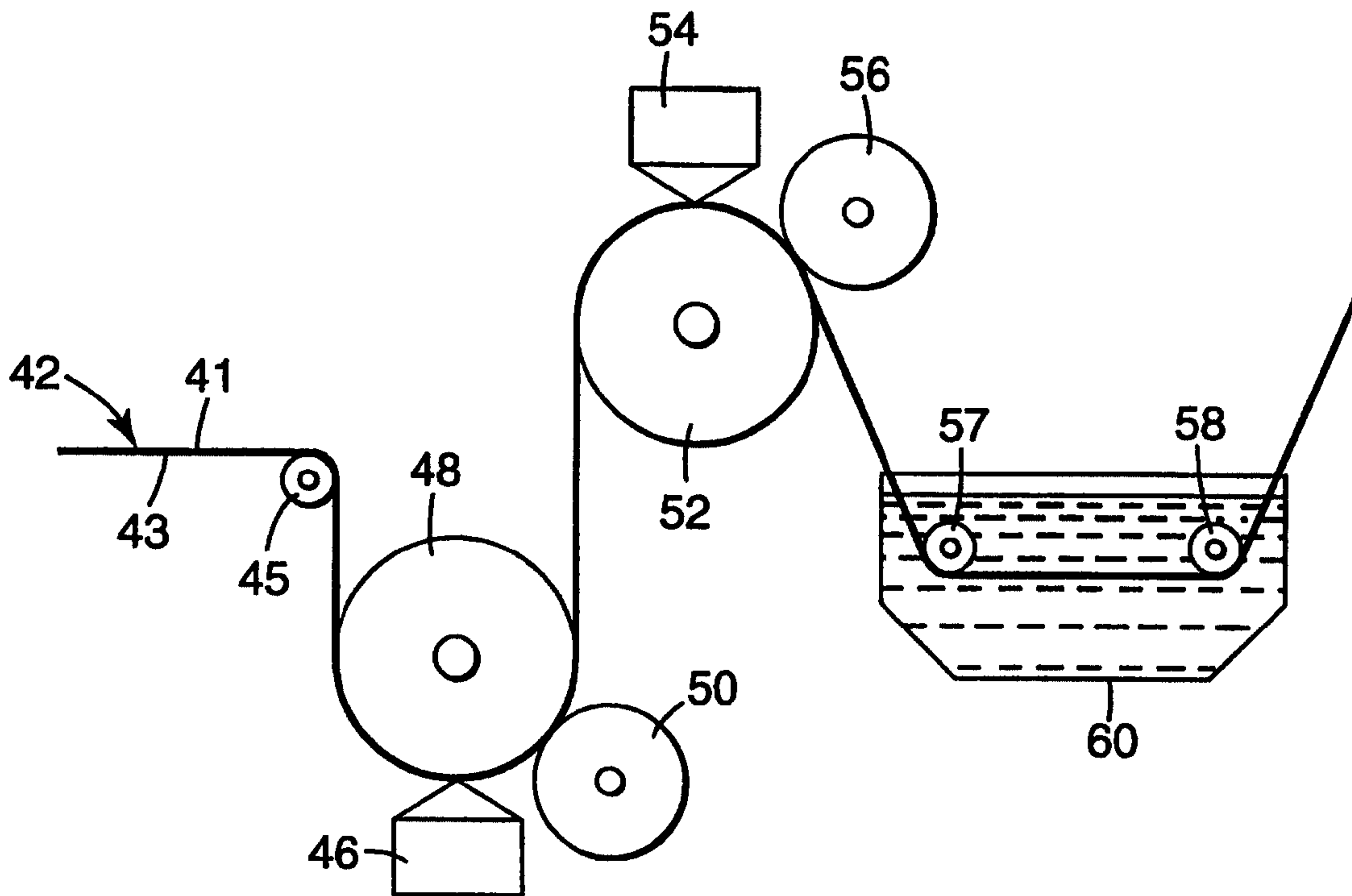

(86) Date de dépôt PCT/PCT Filing Date: 1998/09/23
 (87) Date publication PCT/PCT Publication Date: 1999/04/08
 (45) Date de délivrance/Issue Date: 2007/01/09
 (85) Entrée phase nationale/National Entry: 2000/03/02
 (86) N° demande PCT/PCT Application No.: US 1998/019809
 (87) N° publication PCT/PCT Publication No.: 1999/016608
 (30) Priorité/Priority: 1997/10/01 (US08/942,062)

(51) Cl.Int./Int.Cl. *B29C 59/04* (2006.01),
B29D 7/01 (2006.01), *B29C 35/08* (2006.01)
 (72) Inventeurs/Inventors:
STROBEL, JOAN M., US;
STROBEL, MARK A., US;
HAGER, PATRICK J., US;
KAPAUN, RONALD S., US
 (73) Propriétaire/Owner:
MINNESOTA MINING AND MANUFACTURING
COMPANY, US
 (74) Agent: SMART & BIGGAR

(54) Titre : FILMS POLYMERES ORIENTES ET GAUFRES
 (54) Title: EMBOSSED ORIENTED POLYMER FILMS



(57) Abrégé/Abstract:

Embossed oriented thermoplastic films and a method of making same are described. The embossed oriented thermoplastic films have substantially the same mechanical properties as unembossed oriented thermoplastic films. The method includes providing an oriented thermoplastic film having first and second major surfaces, softening at least one of the first and second major surfaces to produce a softened surface, embossing the softened surface to produce an embossed oriented thermoplastic film, and cooling the embossed oriented thermoplastic film.

**PCT**WORLD INTELLECTUAL PROPERTY ORGANIZATION
International Bureau

INTERNATIONAL APPLICATION PUBLISHED UNDER THE PATENT COOPERATION TREATY (PCT)

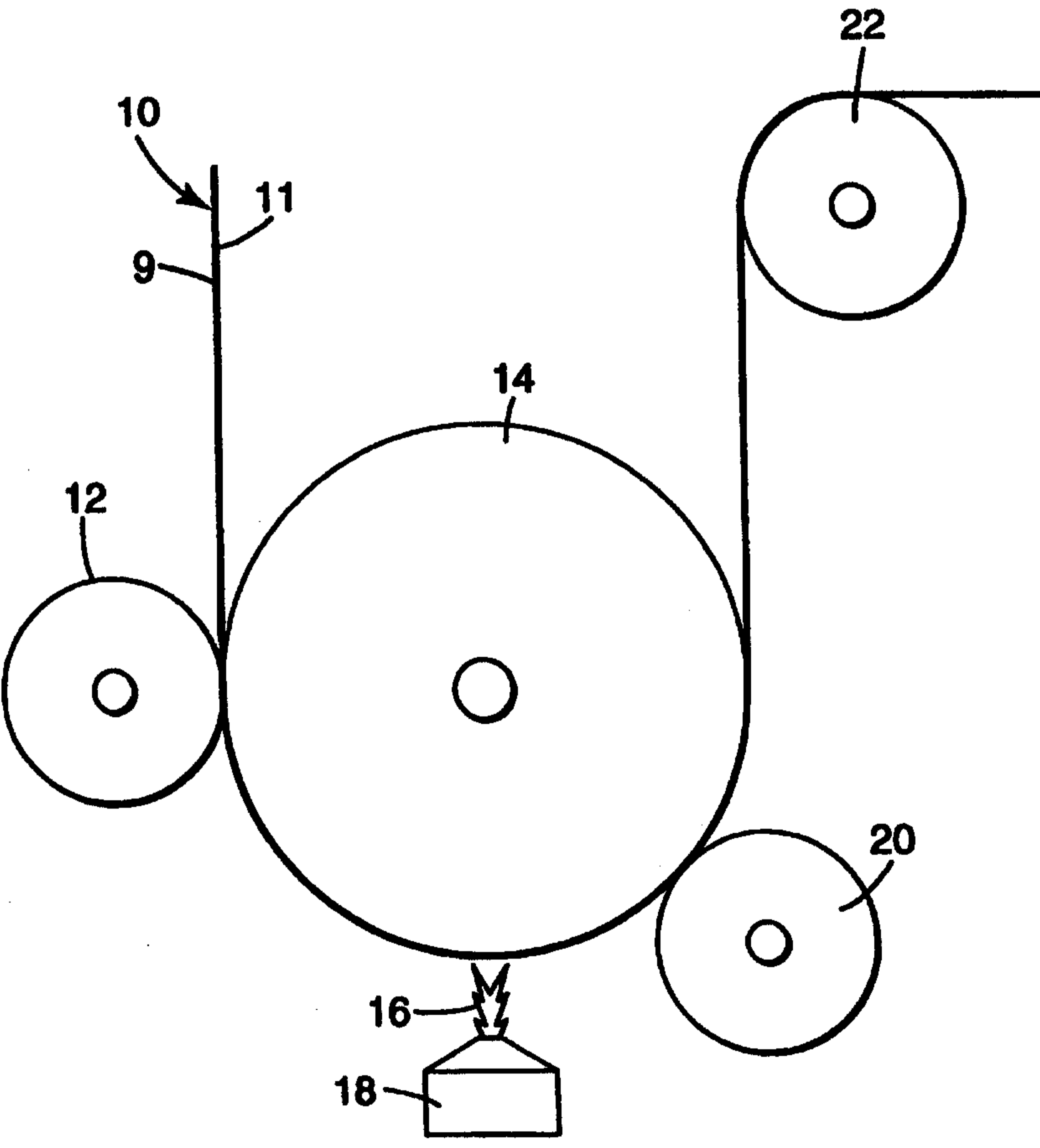
<p>(51) International Patent Classification ⁶ : B29C 59/04, B29D 7/01</p>	<p>A1</p>	<p>(11) International Publication Number: WO 99/16608</p> <p>(43) International Publication Date: 8 April 1999 (08.04.99)</p>
<p>(21) International Application Number: PCT/US98/19809</p> <p>(22) International Filing Date: 23 September 1998 (23.09.98)</p> <p>(30) Priority Data: 08/942,062 1 October 1997 (01.10.97) US</p> <p>(71) Applicant: MINNESOTA MINING AND MANUFACTURING COMPANY [US/US]; 3M Center, P.O. Box 33427, Saint Paul, MN 55133-3427 (US).</p> <p>(72) Inventors: STROBEL, Joan, M.; P.O. Box 33427, Saint Paul, MN 55133-3427 (US). STROBEL, Mark, A.; P.O. Box 33427, Saint Paul, MN 55133-3427 (US). HAGER, Patrick, J.; P.O. Box 33427, Saint Paul, MN 55133-3427 (US). KAPAUN, Ronald, S.; P.O. Box 33427, Saint Paul, MN 55133-3427 (US).</p> <p>(74) Agents: BURTIS, John, A. et al.; Minnesota Mining and Manufacturing Company, Office of Intellectual Property Counsel, P.O. Box 33427, Saint Paul, MN 55133-3427 (US).</p>		<p>(81) Designated States: CA, JP, KR, MX, European patent (AT, BE, CH, CY, DE, DK, ES, FI, FR, GB, GR, IE, IT, LU, MC, NL, PT, SE).</p> <p>Published <i>With international search report.</i></p>
<p>(54) Title: EMBOSSED ORIENTED POLYMER FILMS</p> <p>(57) Abstract</p> <p>Embossed oriented thermoplastic films and a method of making same are described. The embossed oriented thermoplastic films have substantially the same mechanical properties as unembossed oriented thermoplastic films. The method includes providing an oriented thermoplastic film having first and second major surfaces, softening at least one of the first and second major surfaces to produce a softened surface, embossing the softened surface to produce an embossed oriented thermoplastic film, and cooling the embossed oriented thermoplastic film.</p> <div style="text-align: right;">  </div>		

Embossed Oriented Polymer Films

Field of the Invention

5 This invention relates to thermoplastic polymer films. In particular, this invention relates to embossed oriented thermoplastic films and to the process for forming these films.

Background of the Invention

10 The use of oriented films is widespread, particularly with films comprised of semi-crystalline thermoplastic polymers. These oriented films are characterized by high tensile strength and low-to-moderate elongation. Orientation can also influence crystalline order and hence the melting or softening point of an oriented polymer.

15 It is known that unoriented polymeric materials, such as polypropylene, can be embossed during casting. However, in the manufacture of oriented polymer films, the cast-embossing process cannot be used. Orientation of a film is carried out by casting a polymer sheet and subsequently heating and stretching (also known as drawing) the sheet into an oriented film. An embossed pattern produced during the casting of the sheet is destroyed by an orientation process.

20 Embossed polymer films are desirable because of the decorative or other surface effects produced on the films. For example, low gloss values are desirable on embossed polymer films because they are useful, for example, as adhesive-tape backings. Embossing of polymer films is also useful in changing the frictional characteristics of the film (e.g., to alter slip properties) or to alter its adhesion to a surface.

25 Methods to emboss oriented films have been proposed but these require heating to temperatures and for times that cause the oriented polymer film to lose desirable bulk mechanical properties (such as low-to-moderate elongation and high tensile strength). In addition, such methods tend to destroy desirable surface properties of the films. Therefore, the methods often include an additional surface

30

treatment step after embossing to restore some of the surface properties of the oriented film.

There is a need in the art to provide embossed oriented thermoplastic films that do not lose desirable surface properties and substantially retain the properties imparted by orientation (e.g., high tensile strength-at-break and low-to-moderate elongation-at-break) after the embossing process.

Summary of the Invention

Briefly, in one aspect of the present inventions, an embossed oriented thermoplastic film is provided comprising an oriented thermoplastic film having first and second major surfaces and a plurality of embossments on at least one of the first and second major surfaces wherein the tensile strength-at-break and tensile elongation-at-break of the embossed oriented thermoplastic film are substantially the same as the tensile strength-at-break and tensile elongation-at-break of the unembossed oriented thermoplastic film.

In another aspect, this invention is the method of making an embossed oriented thermoplastic film comprising the steps of providing an oriented thermoplastic film having first and second major surfaces, softening at least one of the first and second major surfaces to produce a softened surface, embossing the softened surface to produce an embossed oriented thermoplastic film, and cooling the embossed oriented thermoplastic film. In a preferred embodiment the combined steps of softening, embossing, and cooling occur in less than 1 second.

In a preferred embodiment, a heat flux is provided by a flame to at least one major surface of an oriented thermoplastic film resulting in a softened surface. The film then is passed between a nip having at least one embossing surface to form embossments on the film. This embossed surface is then cooled to fix the structure of the embossments. The time required to heat, emboss, and cool the embossed oriented thermoplastic film ranges from about 0.05 to about 1 second.

The resultant embossed oriented film has substantially the same bulk mechanical properties of the oriented film before embossing. This method imparts variable topography to an oriented film that leads to variation in such characteristics as gloss, friction, and mechanical adhesion. Further, when the softening step is

60557-6245

carried out by flame treatment, this method imparts additional desirable surface characteristics such as improved wetting and chemical adhesion to subsequent coatings. Thus, in a method of this invention, the film is
5 surface treated and embossed in one high-speed operation.

In yet another aspect, this invention is a layered construction comprising an oriented thermoplastic film having first and second major surfaces and a plurality of embossments on at least one of the first and second major
10 surfaces, wherein the tensile strength-at-break and tensile elongation-at-break of the embossed oriented thermoplastic film are substantially the same as the tensile strength-at-break and tensile elongation-at-break of the oriented thermoplastic film before embossing.

15 In yet another aspect, this invention is a method of making a thermoplastic article by providing a layered construction comprising an oriented thermoplastic film having a major surface, softening the major surface to produce a softened surface, embossing the softened surface
20 to produce an embossed layered construction, and cooling the embossed layered construction, wherein the tensile strength-at-break and tensile elongation-at-break of the oriented thermoplastic film in the embossed layered construction are substantially the same as the tensile strength-at-break and
25 tensile elongation-at-break of the oriented thermoplastic film in the layered construction before embossing.

According to one aspect of the present invention, there is provided an embossed oriented semi-crystalline thermoplastic film comprising: an oriented semi-crystalline
30 thermoplastic film having first and second major surfaces; a plurality of embossments on at least one of the first and

60557-6245

second major surfaces, wherein the tensile strength-at-break and tensile elongation-at-break of the embossed oriented semi-crystalline thermoplastic film are substantially the same as the tensile strength-at-break and tensile
5 elongation-at-break of the oriented semi-crystalline thermoplastic film before embossing.

According to another aspect of the present invention, there is provided a layered construction comprising the oriented, semi-crystalline thermoplastic film
10 that is described herein.

According to yet another aspect of the present invention, there is provided a method of making an embossed semi-crystalline oriented thermoplastic film comprising:
providing an oriented thermoplastic film having first and
15 second major surfaces; softening at least one of the first and second major surfaces to produce a softened surface; embossing the softened surface to produce an embossed oriented thermoplastic film; cooling the embossed oriented thermoplastic film; wherein the tensile strength-at-break
20 and tensile elongation-at-break of the embossed oriented thermoplastic film are substantially the same as the tensile strength-at-break and tensile elongation-at-break of the oriented thermoplastic film before embossing.

In this application, "tensile strength-at-break
25 and tensile elongation-at-break of the embossed oriented thermoplastic film are substantially the same as the tensile strength-at-break and tensile elongation-at-break of the unembossed oriented thermoplastic film" means that the tensile strength-at-break of the embossed oriented
30 thermoplastic film has a variance of less than 10 percent from the tensile strength-at-break of the unembossed

60557-6245

oriented thermoplastic film and the tensile elongation-at-break of the embossed oriented thermoplastic film has a variance of less than 10 percent from the tensile elongation-at-break of the unembossed oriented thermoplastic
5 film. Preferably the tensile strength-at-break has a variance of less than 5 percent and/or the tensile elongation-at-break has a variance of less than 5 percent. More preferably there is essentially no change in these properties after embossing.

Brief Description of the Drawing

Figure 1 is a schematic representation of one embodiment of the method of this invention.

Figure 2 is a schematic representation of another embodiment of the method
5 of this invention.

Description of the Preferred Embodiments

The present invention provides an embossed oriented thermoplastic film and a method of making such film. A wide range of oriented thermoplastic polymer films are suitable in the practice of this invention. "Film" refers to planar forms of plastic, thick enough to be self-supporting but thin enough to be flexed, folded, or creased without cracking. Film thickness depends upon desired applications and manufacturing methods. "Oriented" refers to a polymer film that has been stretched
10 in at least one direction to align the polymer molecules; thus generally increasing the tensile strength-at-break and decreasing the elongation-at-break of the polymer film in the direction of orientation over that of the un-stretched polymer film.
15

"Thermoplastic" refers to polymers that soften when exposed to heat and return to their original condition when cooled. Natural substances that exhibit this behavior are crude rubber and a number of waxes. However, the term is usually applied to synthetic polymers as described below. These polymers are distinct from
20 "thermoset" polymers that cure or "set", typically upon exposure to activating radiation such as heat or light, and thus cannot be subsequently softened by heating.

A distinction to be made among thermoplastic polymers used to make films is that some polymers are amorphous and some are semi-crystalline. That is, an amorphous polymer has no long range order as can be determined, for example, by wide-angle X-ray scattering. A further distinction for amorphous polymers is that
25 some are amorphous rubbery polymers, having a glass transition temperature (T_g) below their use temperature, and others are amorphous glassy polymers, having a T_g above their use temperature. Amorphous rubbery polymers are also referred to as "elastomers". Elastomer is a term referring to polymers having properties similar
30 to those of vulcanized natural rubber, namely the ability to be stretched to at least twice their original length and to retract very rapidly to approximately their original

length when released. The term includes uncrosslinked polyolefins that are thermoplastic; these are referred to as thermoplastic olefin rubbers. The mechanical properties of amorphous rubber polymers are typically unaffected by orientation and are unaffected by heat or heating followed by cooling.

5 Amorphous glassy polymers have no well-defined melting point. In contrast to homogeneous amorphous glassy polymers, semi-crystalline polymers are morphologically heterogeneous, having crystalline regions and amorphous regions; they exhibit distinct, reversible melting points. The existence of crystalline regions in semi-crystalline polymers can be detected by methods such as wide-angle X-ray
10 scattering. These polymers can be oriented to increase their tensile strength-at-break and decrease their elongation-at-break. However, heat can also relax the orientation and reduce the beneficial property enhancements obtained by orientation, if heating occurs for a sufficient length of time.

Polymers suitable for use in this invention exhibit a softening transition
15 (either a melting point or a glass transition) above use temperature and they are capable of being formed into oriented films. Amorphous glassy thermoplastic films and semi-crystalline thermoplastic films are suitable for use in making embossed oriented films by the method of this invention.

Oriented thermoplastic polymer films are prepared by methods known in the
20 art, such as heating the polymer to a temperature near or above the softening transition temperature, followed by stretching in one or more directions. Typically, a polymer sheet is extruded (also referred to as "melt extruded") and then oriented by rapid stretching at a desired temperature to form an oriented film, followed by rapid quenching. Quenching ensures that the orientation is not lost by molecular
25 relaxation. Orientation can occur in the direction of film motion, referred to in the art as the machine direction or the longitudinal direction. Films may be oriented in one direction only; such are referred to as uniaxially oriented films. They may also be oriented in two directions, typically orthogonal to each other, and are referred to as biaxially oriented films. The direction orthogonal to the longitudinal direction is
30 referred to as the transverse direction. Mechanical properties of oriented films vary depending upon the direction and degree of orientation and often referenced to the

longitudinal and transverse directions. Orientation typically produces stiffer films with increased modulus, decreased elongation-at-break and increased tensile strength-at-break.

Suitable oriented amorphous glassy thermoplastic films include those comprising acetates such as cellulose acetate, cellulose triacetate and cellulose acetate/butyrate, acrylics such as poly(methyl methacrylate) and poly(ethyl methacrylate), polystyrenes such as poly(p-styrene) and syndiotactic polystyrene, and styrene-based copolymers, vinylics such as poly(vinyl chloride), poly(vinylidene chloride), poly(vinylidene fluoride), poly(vinylidene dichloride) and mixtures thereof.

Preferred oriented amorphous glassy thermoplastic films are those comprising cellulose acetate, poly(p-styrene), syndiotactic polystyrene, poly(vinyl chloride), poly(vinylidene chloride), poly(vinylidene fluoride) and poly(vinylidene dichloride).

Suitable oriented semi-crystalline thermoplastic films include those comprising polyolefin homopolymers such as polyethylene and polypropylene, copolymers of ethylene, propylene and/or 1-butylene; copolymers containing ethylene such as ethylene vinyl acetate and ethylene acrylic acid; polyesters such as poly(ethylene terephthalate), polyethylene butyrate and polyethylene naphthalate; polyamides such as poly(hexamethylene adipamide); polyurethanes; polycarbonates; poly(vinyl alcohol); ketones such as polyetheretherketone; polyphenylene sulfide; and mixtures thereof.

Preferred oriented semi-crystalline polymer films are those comprising polyethylene, polypropylene, poly(ethylene/propylene), poly(ethylene/1-butylene), poly(propylene/1-butylene), poly(ethylene/propylene/1-butylene), poly(ethylene terephthalate), poly(ethylene butyrate), poly(ethylene naphthalate), and mixtures thereof. Particularly preferred films are those comprising linear-low-density polyethylene, high-density polyethylene, ultra-high-molecular-weight polyethylene, isotactic polypropylene, blends of isotactic polypropylene and substantially syndiotactic polypropylene and blends of isotactic polypropylene and polyethylene.

A preferred biaxially oriented semi-crystalline polymer film comprises isotactic polypropylene, also referred to as biaxially oriented polypropylene (BOPP).

5 The oriented thermoplastic polymer films useful in this invention typically range in thickness from about 2 to about 250 micrometers. Preferably, they range in thickness from about 5 to about 150 micrometers, and more preferably, from about 10 to about 75 micrometers.

10 The oriented thermoplastic polymer films useful in this invention may contain fillers, plasticizers, colorants, lubricants, processing aids, nucleating agents, ultraviolet-light stabilizing agents, and other property modifiers. Typically such materials are added to a polymer before it is made into an oriented film (e.g., in the polymer melt before extrusion into a film). Organic fillers may include organic dyes and resins, as well as organic fibers such as nylon and polyimide fibers. Inorganic fillers may include pigments, fumed silica, calcium carbonate, talc, diatomaceous earth, titanium dioxide, carbon fibers, carbon black, glass beads, glass bubbles, mineral fibers, clay particles, metal particles and the like. Filler may be added in amounts up to about 100 parts per 100 parts of the polymer forming the oriented film. Other additives such as flame retardants, stabilizers, antioxidants, compatibilizers, antimicrobial agents (e.g., zinc oxide), electrical conductors, and thermal conductors (e.g., aluminum oxide, boron nitride, aluminum nitride, and nickel particles) can be blended into the polymer used to form the film in amounts of from about 1 to about 50 volume percent.

25 In the method of this invention, a layered construction, also known as a multilayered film, may be used as the input film. Such films include, for example, layers of films that are formed by co-extrusion with one or more other polymers, films coated with another layer, or films laminated or adhered together. The major surface of the oriented thermoplastic film comprises the layer that is to be softened, embossed, and cooled.

30 The embossed oriented thermoplastic films of this invention may be made into layered constructions with other films. Such films may be oriented thermoplastic films or may be unoriented thermoplastic films. Such would include

amorphous rubbery, amorphous glassy, and semi-crystalline films. Layers which serve as backing layers could also be used. Backings could be in the form of single or multilayered films, porous films, foam-like films, woven or non-woven materials, metal foils, and combinations of the foregoing. Layers comprising adhesive could also be used in a layered construction. Adhesives could be hot-melt, having substantially no tack at room temperature, or pressure-sensitive, having a balance of shear and adhesive properties at room temperature. Pressure-sensitive adhesives include, for example, acrylic, segmented block copolymer, rubber, α -olefin, silicone, polyvinyl ether, and urethane. A particularly useful adhesive may comprise acrylic adhesive (isooctyl acrylate (95%)/acrylic acid(4.5%)). Preferably, the layer of pressure sensitive adhesive is uniform and has an adhesion to glass of less than 17 grams/millimeter. Adhesives for use with this invention are described in U.S. Patent Nos. 4,699,842; 3,578,622; 3,331,729; 2,926,105; and 4,835,217.

In the method of this invention, an oriented thermoplastic film having a first and second major surface is provided. The thermoplastic film moves between or over rollers or the like that serve to control the film tension. At least one of the first and second major surfaces of the film is exposed to a heat flux from a heat source such as a flame, a plasma torch, and the like. Heat sources result in a softened surface in the desired time frame, that is, rapidly enough to cause softening of the film surface without causing a significant change in the orientation and/or properties of the bulk film. A preferred heat source is a flame. Heat flux causes the surface of the film to soften.

The film may move over a support, such as a backing roll, while being exposed to the source of heat. A support for the film can minimize distortion of the film during heating. The heat source provides sufficient heat to the surface of the oriented thermoplastic film to soften the surface as necessary for embossing. Embossing can be carried out by any means known in the art. The preferred method of embossing is to move the softened film through a nip having an embossing surface. "Nip" refers to two rolls in proximity that apply pressure on a film when the film passes between them. The embossing surface contacts the film with sufficient force to create embossments in the softened surface of the film. The

embossed film is then cooled by any of a number of methods to reduce the temperature of the softened surface to below its softening temperature before the softened film has experienced a significant change in bulk properties resulting from prior orientation. Such methods include moving the film over one or more chilled
5 rollers, delivering it to a water bath, or cooling by air or other gases, such as by use of an air knife.

In this application, "dwell time" is defined as the time it takes for the combined steps of softening, embossing, and cooling the film. Dwell time will vary depending upon the configuration (e.g., equipment size and film speed) of the
10 system used to heat, emboss, and cool the film. The time of exposure to heat should be sufficient to soften the surface of the oriented thermoplastic film prior to contact with the embossing roll and the dwell time should not be so long as to cause destruction of the mechanical properties of the film. Thus, in preferred
embodiments, the dwell time is as short as possible.

15 An embodiment of the method of this invention is illustrated in Figure 1. Oriented thermoplastic film 10 having major surfaces 9 and 11 is passed between nip roll 12 and backing roll 14 to control the tension on the film, but other methods to control the tension can also be used. Both nip roll 12 and backing roll 14 are covered with a smooth layer that insures intimate contact between rolls 12 and 14
20 and film 10. Suitable covering layers for the backing roll and the nip roll include elastomers such as neoprene, nitrile rubber, silicone rubber, polyether urethane rubber, chlorosulfonated rubber, polytetrafluoroethylene (PTFE), and the like. The temperature of either or both rolls can be controlled by means of a water recirculation system.

25 Major surface 9 of film 10 moves over flame 16 provided by ribbon burner 18. Rapid heating of major surface 9 occurs. Film 10 is transported between backing roll 14 and male-patterned metal-plated embossing roll 20 to form an embossed surface of film 10 having a reverse pattern of that machined into embossing roll 20.

30 Embossing roll 20 is forced against backing roll 14 by means of pneumatic or hydraulic cylinders and lever mechanisms as are known in the art. The force

applied to embossing roll 20 is controlled by varying pressure to the cylinders and by varying the width of contact between embossing roll 20 and backing roll 14. Typically the force applied to embossing roll 20 varies from about 17.5 to about 1050 N/lineal cm (10 to about 600 pounds/lineal inch). The applied force should be
5 sufficient to emboss a desired pattern into the thermoplastic film.

Film 10 is then cooled by moving over water cooled chill roll 22. Those skilled in the art recognize that other cooling means can be used. For example, an air knife, evaporating liquid nitrogen, or a water bath could be used to cool the surface of the thermoplastic film as it leaves the embossing roll.

10 The time for a point on surface 9 to be softened as it moves over flame 16, through backing roll 14 and embossing roll 20 and to be cooled below its softening point as it moves over chill roll 22 is the "dwell time". The dwell time typically ranges from about 0.05 seconds to about 1 second and preferably ranges from about 0.1 to about 0.3 seconds. The time of exposure to the heat from the flame
15 should be sufficient to soften the surface of the oriented thermoplastic film prior to contact with the embossing roll and the dwell time should not be so long as to cause destruction of the mechanical properties of the film.

Flame burner 18 ordinarily uses premixed flames in which the fuel and oxidizer are thoroughly mixed prior to combustion and the rate of combustion is
20 controlled by the rate of chemical reactions that occurs in the flame. In a premixed flame, the luminous region is that portion of the flame where the temperature rise is the greatest and where much of the reaction and heat release occur. To rapidly heat a polymer film to elevated temperatures, both premixed and diffusion flames can be used. In a diffusion flame, separate fuel and oxidizer streams come together
25 through molecular and turbulent diffusion. In diffusion flames, the rate of combustion is controlled by the rate of mixing of the reactants. Unlike premixed flames, which typically have a narrow, 1-2 mm wide reaction zone, diffusion flames have a wider region through which the chemical composition changes and chemical reaction takes place. Both premixed and diffusion flames can be either laminar or
30 turbulent.

Flames are commonly described in terms of two characteristics: flame power and molar ratio of oxidizer to fuel. Flame power is the product of the volume of fuel burned per unit time and the heat content of the fuel. Typical units for flame power are W or Btu/hr. In flame treating, flame power can be normalized to account for the dimensions of the burner, leading to units such as W/cm² or Btu/hr-in². The exact ratio of oxidizer to fuel needed for complete combustion is known as stoichiometric ratio. For example, the exact amount of dry air necessary for the complete combustion of methane is 9.55 volumes per volume of methane. As an example, the stoichiometric ratio for an air:methane flame is 9.55:1. The equivalence ratio is defined as the stoichiometric oxidizer:fuel ratio divided by the actual oxidizer:fuel ratio. For fuel-lean flames, there is more than the stoichiometric amount of oxidizer and so the equivalence ratio is less than 1.00. For oxidizer:fuel mixtures at the stoichiometric ratio, the equivalence ratio is exactly 1.00. For fuel-rich systems, the equivalence ratio is greater than 1.00.

Flame treating equipment useful for this invention is any that can provide a flame in close proximity to the polymer surface. Generally, the film surface is flame treated as the film moves over a cooled support, e.g., a cooled roll, to prevent film distortion. Flame treating equipment includes commercial systems manufactured by, for example, The Aerogen Company, Ltd., Alton, United Kingdom, and Sherman Treaters Ltd., Thame, United Kingdom. Preferably the equipment has a mixer to combine an oxidizer with fuel. A ribbon burner is best suited for the flame treatment of polymer films, but other types of burners may also be used.

The flame has an optimal distance from the polymeric substrate surface and is supported by a mixture of oxidizer and fuel. The distance between the tip of the luminous cone of the flame and the surface of the polymer ranges between about 30 mm to about -2 mm, i.e., the film is contacted by the flame and occupies space that would otherwise comprise the terminal 2 mm of the flame tip. Preferably the distance is between 0 mm and 10 mm. The fuel has a lower electronegativity than the oxidizer. Suitable fuels include, for example, natural gas, methane, ethane, propane, butane, ethylene, liquefied petroleum gas, acetylene, carbon monoxide, dimethyl ether, ammonia, and blends thereof. Suitable oxidizers include air,

oxygen-enriched air, and nitrous oxide-enriched air. The oxidizer reacts with the fuel to form chemical species that may react with the surface of the thermoplastic film.

Turning now to Figure 2, another embodiment of the method of this invention is shown. In this embodiment, both major surfaces of the oriented thermoplastic film are softened and embossed. Oriented thermoplastic film 42 having major surfaces 41 and 43 moves over idler roll 45 which serves to control the tension of the film. Film 42 is transported to backing roll 48. Major surface 43 of film 42 moves over heat source 46. Suitable heat sources include a plasma torch and a flame, provided, for example, by a ribbon burner. Rapid heating of major surface 43 occurs. Film 42 is transported between backing roll 48 and male-patterned embossing roll 50 to produce embossments on major surface 43. Film 42 is transported to second backing roll 52 arranged so that major surface 41 moves proximate to second heat source 54. Heat source 54 may be the same type as heat source 46, or may be a different type of heat source. Rapid heating of major surface 41 occurs. Film 42 is then transported between backing roll 52 and embossing roll 56 to produce embossments on major surface 41. Film 42 proceeds to idler rolls 57 and 58 that hold the film in tension while it goes through water bath 60. An air knife would also be suitable cooling means and could be substituted for the water bath.

Returning now to the method of this invention, embossing refers to a process in which a pattern is impressed into the surface of an article. Embossing is typically accomplished by means of a male pattern formed on a hard material such as a metal layer on an embossing roll, as depicted by 20 in Figure 1. Those skilled in the art recognize that embossing can be done by several methods, including the use of a continuous tooled belt or sleeve. Preferred metal layers include those comprising nickel, copper, steel, and stainless steel. Patterns are typically machined into the metal layer and can have a wide variety of sizes and shapes. Any pattern that can be scribed into a metal surface can be used in the practice of this invention. "Pattern" does not necessarily refer to a regular repeating array, but may mean a random array of features having the same or different sizes. Patterns suitable for

WO 99/16608

PCT/US98/19809

the practice of this invention include four-sided square pyramids, truncated four-sided square pyramids, cones, straight lines, wavy lines, and the like and are machined into at least a portion of the embossing roll. An individual feature of the pattern is referred to as an embossment. The number and spacing of embossments, as well as the nature of the individual embossment, such as its depth, degree of sharp reflecting edges, and shape can be varied as desired.

As exemplified below, a plurality of embossments are formed on the oriented thermoplastic film. There are typically about 15 to about 150 embossments per lineal centimeter (40 - 400 per lineal inch). The embossments can be of any suitable depth, as long as the mechanical properties of the films are substantially retained after the embossments have been formed. The depth of an embossment typically ranges from greater than zero to about 90 percent of the thickness of the oriented thermoplastic film. In the patterns exemplified below, the depth of an embossment ranges from about 0.02 mm to about 0.2 mm.

Regardless of the embossing pattern, the bulk mechanical properties of the embossed oriented thermoplastic film are substantially the same as those of the oriented thermoplastic film. That is, the tensile strength-at-break of the embossed oriented thermoplastic film has a variance of less than 10 percent from the tensile strength-at-break of the unembossed oriented thermoplastic film and the tensile elongation-at-break of the embossed oriented thermoplastic film has a variance of less than 10 percent from the tensile elongation-at-break of the unembossed oriented thermoplastic film. Preferably the tensile strength-at-break has a variance of less than 5 percent and/or the tensile elongation-at-break has a variance of less than 5 percent. More preferably there is essentially no change in these properties after embossing.

It is believed that the bulk mechanical properties do not change substantially because the oriented thermoplastic film spends only a short time at elevated temperatures and the entire film is not heated above the softening temperature of the polymer. Time is an important consideration, because heating at or above the softening temperature of the polymer for prolonged periods can cause loss of orientation, and hence, loss of desirable mechanical properties. Avoiding conditions

sufficient to melt the polymer is also advantageous, since molten polymer adheres to the embossing rolls and results in significant damage to the polymer film. In addition, the mechanical properties of the film are significantly altered if melting occurs because the polymer chains making up the oriented polymer have increased mobility and sufficient time to lose their orientation.

When a polymeric film is oriented, the tensile strength-at-break in the direction of orientation is significantly increased and the elongation-to-break in the oriented direction is significantly reduced. This results in a film that is significantly stronger than its unoriented counterpart. Significant bulk mechanical properties of oriented thermoplastic films include stress properties, such as tensile strength-at-break, and strain properties such as percent elongation-at-break. These properties are measured on films conditioned for 24 hours at 22°C (72°F) and 50% relative humidity (RH). Measurements are performed on film strips cut from the longitudinal direction and from the transverse direction of the film, since the values may vary depending upon the degree of orientation of the film. For example, a typical biaxially oriented polypropylene film has a tensile strength-at-break of about 144 N/mm² (20,000 psi) in the longitudinal direction and of about 280 N/mm² (39,000 psi) in the transverse direction.

When an oriented thermoplastic film is softened for a prolonged period of time or is melted, the oriented and ordered regions tend to become disordered. This often results in a decrease in tensile strength-at-break and an increase in elongation-at-break if the disorder is substantial. However, it is not uncommon to observe increases in tensile strength-at-break and/or decreases in elongation-at-break when the disorder is not substantial, i.e., less than about 10% change from the unembossed state.

Tensile strength-at-break is a measure of the force on the film strip at the time of rupture divided by the original cross-sectional area of the test strip. Percent elongation-at-break is a measure of the change in length of the film strip at the time of rupture divided by the original length of the test strip and multiplied by 100. Measurement of these properties before and after embossing a film, whether by the process of this invention or by other processes described in the art, provides an

understanding of the effect of various processes on the mechanical properties of a film.

When the source of heat is a flame, the method of this invention provides a means of both embossing and treating the surface of an oriented thermoplastic polymer film. That is, "treating" means that both the wetting and adhesion characteristics of the polymer can be improved. This is because a flame is both a source of heat and of active chemical species, and so not only heats the polymer film but also oxidizes the surface of the film.

The process of this invention also provides various surface topographies. Changes to the topography can be useful in producing surfaces that have desirable release, adhesion, or gloss properties.

Gloss is an important property for some applications of embossed oriented thermoplastic film. Gloss is a measure of the light reflected from the film surface at the specular angle, the angle equal and opposite to the angle of the incident light source. To arrive at a specific gloss level on, for example, an oriented polypropylene film, embossing is conducted to cause intentional defects in the glossy surface of the film, thereby reducing the ratio of specular reflectance to diffuse reflectance. This ratio is affected by the number and spacing of embossments, as well as by the nature of the individual embossment, such as its depth, degree of sharp reflecting edges, and shape. A patterned nip roll is fabricated to provide the correct balance of specular reflectance to diffuse reflectance. Reductions in specular gloss can be accomplished by, for example, holding the type of pattern constant, while varying the depth and spacing of the pattern. In this way, the specular reflectance decreases with an increasing amount of diffuse reflecting asperities.

The embossed oriented thermoplastic films of this invention may be used as stand-alone or self-supporting films or may be made into constructions with other layers. The embossed oriented thermoplastic films are useful as components of products including adhesive tapes, release liners, photographic or imaging films, and magnetic storage media and the like.

Examples

This invention is further illustrated by the following examples that are not intended to limit the scope of the invention. In the examples, all parts, ratios and percentages are by weight unless otherwise indicated. The following test methods
5 were used to evaluate and characterize the low adhesion backsize compositions produced in the examples. All materials are commercially available, for example from Aldrich Chemicals, unless otherwise indicated or described.

Test Methods

Film Tensile Property Determinations

10 The tensile strength-at-break and tensile elongation-at-break of the films were measured by the procedures described in ASTM D-882, "Tensile Properties of Thin Plastic Sheeting", Method A. The films were conditioned for 24 hours at 22° C (72°F) and 50 percent relative humidity (RH). The tests were performed using a
15 tensile-testing machine commercially available as a Model No. 4502 from Instron Corporation of Canton, MA. Specimens for this test were 1.25 cm in width and 15 cm in length. An initial jaw separation of 5 cm and a crosshead speed of 30 cm/min were used. Ten specimens were tested for each sample, five in the longitudinal direction (LD) (i.e., machine direction) and five in the transverse direction (TD).

Tensile values are reported in Table 2. The difference in the tensile
20 strength-at-break and the tensile elongation-at-break between unembossed film and embossed film is expressed as "delta" and reported as a percentage. Delta is calculated by subtracting the value (of the tensile strength-at-break or the tensile elongation-at-break) of an embossed oriented film from the value of an unembossed oriented film, and dividing by the value of the unembossed oriented film (i.e.,
25 (unembossed oriented film - embossed oriented film) ÷ unembossed oriented film) and multiplying by 100.

Gloss Determination

Gloss is a measure of the light reflected from the film surface at the specular angle, that is, the angle equal and opposite to the angle of the incident light source.
30 Gloss was measured according to the procedures described in ASTM D-2457,

WO 99/16608

PCT/US98/19809

“Test for Specular Gloss of Plastic Films” using a gloss meter at a 60° measurement angle (commercially available under the trade designation “ProGloss Pro-3” from Hunter Associates Lab of Reston, Virginia). Because all of the samples were transparent, a matte-black backing surface was placed beneath each test specimen
5 prior to the measurements. Five measurements were made for each film sample to obtain an average percent gloss.

Surface Topography Determination

The topography of the embossed films was determined using a surface roughness measuring device (commercially available as Model RST Plus from
10 Wyko Corporation of Tucson, AZ). This device uses the technique of vertical scanning interferometry (VSI) to determine roughness. In this technique, light reflected from a reference mirror combines with light reflected from the sample surface to produce interference fringes. The roughness measuring device measures the degree of fringe modulation, or coherence. A computer algorithm processes
15 fringe-modulation data from the intensity of the reflected light to calculate surface heights. Using this technique, the vertical resolution from a single measurement is 3 nm. Another computer algorithm calculates the average and total roughness heights. The total roughness height, R_t , is the greatest peak-to-valley profile distance.

20 *Wetting Test*

Estimation of the wetting tension of a polymer film surface is made by wiping a series of liquids of different surface tensions over different regions of the surface of a polymer film sample according to ASTM D-2578, “Wetting Tension of Polyethylene and Polypropylene Films” The wetting tension of the film surface is
25 approximated by the surface tension of the liquid that just wets the film surface. The untreated polypropylene and untreated poly(ethylene terephthalate) (PET) films used in this study had ASTM wetting test values of 29 mJ/m² and 48 mJ/m², respectively.

Surface Composition Determination

30 X-ray photoelectron spectroscopy (XPS or ESCA) was performed on a spectrometer using a monochromatic AlK_α photon source at an electron take-off

angle with respect to the surface of 38° (commercially available from Hewlett-Packard as Model 5950B). Spectra were referenced with respect to the 285.0 eV carbon 1s level observed for hydrocarbon. From the ESCA spectra, O/C atomic ratios were obtained. The typical standard deviation of the O/C ratios obtained
5 from ESCA was ± 0.02 .

Example 1

This example illustrates the preparation of an embossed oriented polypropylene film.

A combustible mixture was formed by mixing together an oxidizer
10 comprised of dust-filtered compressed air (at 25°C , having a dew point of less than about -10°C) with a natural gas fuel in a venturi mixer (Flowmixer Model 88-9 available from Pyronics Inc. of Cleveland, Ohio). The natural gas fuel had a specific gravity of 0.577; a stoichiometric ratio for dry air : natural gas of 9.6:1, and a heat content of 37.3 kJ/L. The flow rates of the air and natural gas were measured with
15 flowmeters (Model 5812 (8-400 Lpm) and Model 5811 (1-50 Lpm)) (both commercially available from Brooks Instrument of Hatfield, PA). The mass flowmeters were calibrated using in-line cumulative-flow meters that operate on the displacement principle (commercially available from Rockwell International of Pittsburgh, PA). The natural gas and air flows were controlled with control valves
20 (available from Badger Meter Inc. of Tulsa, OK). All flows were adjusted to result in a flame equivalence ratio of 1.00 and a normalized flame power of 580 W/cm^2 . The combustible mixture passed through a pipe 3 meters long to a ribbon burner. The ribbon burner was a 35 cm x 1 cm stainless steel ribbon mounted in a cast-iron housing (available as Part No. FMB-206 from The Aerogen Company Ltd. of
25 Alton, United Kingdom).

The burner was mounted directly beneath a 25 cm-diameter, 40 cm-face-width steel chill roll (manufactured by F. R. Gross Company of Stow, Ohio). The chill roll had a 6 mm-thick covering of silicone elastomer (No. FS-8725, having a Shore A Durometer of 80-90, available from the American Roller Company of
30 Kansasville, WI). The backing roll was held at 30°C by means of a water-recirculation system (commercially available under the trade designation

“STERLCO” from Sterling Inc. of Milwaukee, WI). An electric spark ignited the combustible mixture. Stable conical flames were formed with tips 2-3 mm above the topmost surface of the ribbon burner. The input film was thermally extruded, biaxially oriented homopolymer polypropylene (BOPP) film (0.049 mm (1.9 mil) average thickness, 30 cm wide). The film, moving at 120 meters/min, was guided by idler rolls to the backing roll. The distance between the uppermost surface of the ribbon burner and the backing roll was adjusted to maintain a distance of 6-8 mm between the tips of the luminous stable flame cones and the surface of the BOPP film. To insure intimate contact between the substrate and the backing roll, a 10 cm-diameter, 40 cm-face-width nip roll, covered with polyether urethane elastomer (80-90 Shore A Durometer, available from the American Roller Company), was located at the 9 o'clock position on the input side of the backing roll as the film moved from left to right. The front side of the BOPP film was exposed to the laminar premixed flame while the back side was cooled by contact with the elastomer-covered backing roll.

After exposure to the flame, the BOPP film was embossed by contact with a 10 cm-diameter, 40 cm-face-width embossing nip roll located at the 4 o'clock position on the output side of the backing roll. The zone where heating of the BOPP film occurred was essentially between the inbound nip and the outbound embossing nip, or about 40% of the circumference of the backing roll. Using this value as the dimension of the heating zone, the exposure time of the BOPP film to the heat of the flame was about 0.15 seconds. The dwell time, that is, the time of the combined steps of heating the film surface by the flame, embossing the film by contacting it with the embossing roll, and cooling the film surface below its softening temperature, was about 0.3 seconds.

The embossing nip roll consisted of a water-cooled steel core plated with a 0.9 mm thick coating of electroless copper that had a male-pattern cut into the copper. The pattern was cut into the central 5 cm of the nip roll, while the copper coating on the 17.5 cm of unpatterned nip-roll face on either side of the male pattern was reduced to a thickness of 0.5 mm. This caused the patterned portion of the embossing nip roll to be the only area of contact between the nip roll and the

backing roll. The pattern was a truncated square pyramid with a base dimension of approximately 0.14 mm and a top dimension of approximately 0.03 mm, with 50 pyramids per centimeter of face width. The temperature of the embossing nip roll was held at 25 °C by a water-recirculation system ("STERLCO"). The embossing nip roll was forced against the film and backing roll by means of pressurized air cylinders that applied a total of about 1100 Newtons (250 pounds-force) against the backing roll, resulting in a force of about 220 Newtons-per-lineal-centimeter (125 pounds-per-lineal-inch) across the 5 cm face-width that contained the male embossing pattern.

The effects of flame treatment and embossing on the oriented thermoplastic film are shown by the data in the Tables below.

The data in Table 1 show that the 60° gloss of the embossed BOPP film was much less than that of the unembossed film. This reduction in gloss was caused by the presence of embossments. These embossments had a total height from peak-to-valley (R_t) of 6.8 micrometers. As shown in Table 2, the tensile strength-at-break and the tensile elongation-at-break of the embossed BOPP film differed from the unembossed film by less than 5%, indicating the the films were not substantially altered by the heating and embossing process. Finally, as shown by the wetting and ESCA data in Table 1, the embossed BOPP film had increased wettability and an increased level of surface oxidation, indicating that the BOPP film was simultaneously embossed and surface treated by the process.

Example 2

This example illustrates the preparation of an embossed oriented polymer film using the same input film as in Example 1 and similar to the procedure of Example 1, except that the backing roll was covered with a 1 mm-thick coating of polyether urethane elastomer (available as No. LK-285 available from American Roller Company). The effect of surface treatment and embossing on the oriented thermoplastic film is shown by the data in the Tables below.

Example 3

This example illustrates the preparation of an embossed biaxially oriented poly(ethylene terephthalate) film. The preparation was similar to the procedure of

Example 1, except that a 25-cm-diameter, 40 cm-face-width steel chill roll having a 2 mm-thick covering of chlorosulfonated rubber elastomer (80-85 Shore A Durometer, available from the American Roller Company under the trade designation "HYPALON") was used. The input film was 30 cm-wide, 0.014 mm
5 (0.6 mil) thick biaxially oriented poly(ethylene terephthalate) (PET). The film speed was about 180 meters/min.

After exposure to the flame, the PET was embossed by contact with a 15 cm-diameter, 40 cm-face-width embossing nip roll located at the 4 o'clock position on the output side of the backing roll. The embossing nip roll had a water-cooled
10 steel core plated with a 0.9 mm thick coating of electroless copper that had a male pattern. The pattern was a truncated square pyramid with a base dimension of approximately 0.2 mm and a top dimension of approximately 0.06 mm, with 50 pyramids per centimeter of face width. The embossing nip roll was forced against the film and chilled backing roll by means of pressurized air cylinders that applied a
15 total of about 41,600 Newtons (8900 pounds-force) against the backing roll, resulting in a force of about 1050 Newtons-per-lineal-centimeter (600 pounds-per-lineal-inch) across the 40 cm face-width of the embossing roll.

The effects of surface treatment and embossing on the oriented thermoplastic film are shown by the data in the Tables below.

20 *Example 4*

This example illustrates the preparation of an embossed oriented thermoplastic film prepared as described in Example 1, except that the input film was 30 cm-wide 0.040 mm (1.6 mil) thick oriented polypropylene film (commercially available from 4P Folie Forchheim GmbH of Forchheim, Germany),
25 and the film speed was 150 meters/min. The effects of surface treatment and embossing on the oriented thermoplastic film are shown by the data in the Tables below.

Comparative Example 1

The properties of an unembossed biaxially oriented polypropylene film (used
30 as the input film of Examples 1 and 2) were measured. The results are shown in the Tables below. The properties of the film of this comparative example were

compared with those of the embossed oriented films prepared as described in both Examples 1 and 2 to illustrate that softening the surface of a film and embossing it according to this method does not significantly alter the mechanical properties of the oriented film. The surface characteristics of the film, however, are changed by the process to produce lower gloss values, increased wettability, and increased level of surface oxidation. Such changes in surface characteristics are desirable for many applications.

Comparative Example 2

The properties of the unembossed biaxially oriented poly(ethylene terephthalate) (PET) film used as the input film in Example 3 were measured. The results are shown in the Tables below. The properties of the film of this comparative example were compared with those of the embossed biaxially oriented poly(ethylene) terephthalate (PET) film prepared as described in Example 3 to illustrate that softening the surface of an oriented film and embossing it does not significantly alter the mechanical properties of the oriented film. The surface characteristics of the film, however, are changed by the process to produce a lower gloss value, increased wettability, and an increased level of surface oxidation. Such changes in surface characteristics are desirable for many applications.

Comparative Example 3

The properties of the unembossed biaxially oriented polypropylene film used as the input film in Example 4 were measured. The results are shown in the Tables below. The properties of this film were compared with those of the embossed oriented polypropylene film prepared as described in Example 4 to illustrate that softening the surface of an oriented film and embossing it does not significantly alter the mechanical properties of the oriented film. The surface characteristics of the film, however, are changed by the process to produce a lower gloss value, increased wettability, and an increased level of surface oxidation.

Comparative Examples 4a and 4b

The properties of a biaxially oriented polypropylene (BOPP) film having a thickness of 50 micrometers (2 mils), commercially available from Mobil Chemical Co. of Belleville, Ontario, Canada, were measured and are reported in the Tables

below as Comparative Example 4a. This film was used to compare directly to the properties of a film processed according to that disclosed in Example 2 of U.S. Patent No. 5,328,653. Example 2 of the U.S. Patent describe a process for forming a thin heat-sealable semi-crystalline surface layer on a semi-crystalline oriented polymer. This is done by using a heated textured surface, such as a heated roll (referred to as a "hot-can"), to rapidly heat a thin layer of the oriented polymer. The texture on the heated roll is transferred to the surface layer of a film, thus embossing the film surface.

The BOPP film was moved at 23 m/min (75 fpm) over a rubber backup roll and through a nip formed by the backing roll and a textured metal roll coated with polytetrafluoroethylene (commercially available under the tradename TEFLON) that was heated to a surface temperature of 260°C. The efficient heat transfer between the heated metal roll and the BOPP film was sufficient to alter the surface and create an amorphous layer on the contact side of the BOPP film.

The mechanical property data indicate that the hot-can process (i.e., Comparative Example 4b) adversely affects the mechanical properties of an embossed oriented film. Further, the wetting properties of a film treated by the hot-can process are not improved.

When the bulk properties of the film of the unembossed oriented film (4a) were compared with those of the textured film (4b), it was evident that the process used to make the film of Comparative Example 4b caused significant heat damage to the extent that the film was embrittled. The bulk film properties are shown in Table 2 below.

Comparative Examples 5a and 5b

The properties of a commercially available unembossed biaxially oriented polypropylene film were measured and compared with those of a commercially available embossed biaxially oriented polypropylene film. The films, each having a thickness of 35 micrometers (1.4 mils), were obtained from 4P Folie Forchheim GmbH of Forchheim, Germany. Comparative Example 5a was the unembossed film. Comparative Example 5b was embossed on one major surface. The embossed finish was similar to the of the finish described in Example 1.

The tensile strength-at-break and tensile elongation-at-break of the commercially available embossed film (C5b) were significantly different from those of the unembossed film (C5a) in the transverse direction (TD). This indicated that the embossed film had significant heat damage (as compared to the commercially available unembossed film). This indicates that the process used to produce this embossed film does not substantially retain the mechanical properties of the unembossed film.

TABLE 1**Surface Characteristics of Oriented Films**

Example Number	60° gloss	Wetting (mJ/m ²)	ESCA O/C Ratio	Max Depth (micrometers) [R ₁]
C1	153	29	0.00	0
E1	22	50	0.12	6.8
E2	30	44	0.10	5.4
C2	156	46	0.40	0
E3	24	65	0.56	6.2
C3	146	-	-	-
E4	32	-	-	-
C4a	143	29	0.00	-
C4b	16	29	0.00	-
C5a	146	-	-	-
C5b	30	-	-	-

TABLE 2
Bulk Mechanical Properties

Example Number And test direction	Thickness (mm)	Tensile Strength- at-Break (N/mm ²)	delta Tensile Strength-at- Break	Tensile Elongation-at- Break (%)	delta Tensile Elongation- at-Break (%)
E1, LD	0.048	142	-1.4	188	2.6
E2, LD	0.050	138	1.4	193	0
C1, LD	0.049	140		193	
E1, TD	0.049	260	0.4	51	0
E2, TD	0.050	250	3.8	53	-3.9
C1, TD	0.049	261		51	
E3, LD	0.014	206	-7.8	136	4.2
C2, LD	0.014	191		142	
E3, TD	0.014	261	1.5	83	-5.1
C2, TD	0.014	265		79	
E4, LD	0.040	170	-4.3	105	-8.2
C3, LD	0.043	163		97	
E4, TD	0.038	159	0.6	110	4.3
C3, TD	0.040	160		115	
C4b, LD	0.055	100	25.0	205	5.3
C4a, LD	0.049	125		217	
C4b, TD	0.054	206	18.6	50	15.2
C4a, TD	0.049	253		59	
C5b, LD	0.032	179	-4.1	100	3.8
C5a, LD	0.031	172		104	
C5b, TD	0.032	150	18.9	151	21.8
C5a, TD	0.031	185		124	

WO 99/16608

PCT/US98/19809

Although the preferred embodiment of the invention has been discussed and described in detail, it will be appreciated that changes and modifications to the described embodiment can be made by those skilled in the art without departing from the true spirit and scope of the invention, as set forth in the claims.

60557-6245

CLAIMS:

1. An embossed oriented semi-crystalline thermoplastic film comprising:

an oriented semi-crystalline thermoplastic film
5 having first and second major surfaces;

a plurality of embossments on at least one of the first and second major surfaces, wherein the tensile strength-at-break and tensile elongation-at-break of the embossed oriented semi-crystalline thermoplastic film are
10 substantially the same as the tensile strength-at-break and tensile elongation-at-break of the oriented semi-crystalline thermoplastic film before embossing.

2. The embossed oriented semi-crystalline thermoplastic film of claim 1, wherein the tensile strength-at-break of the embossed oriented thermoplastic film has a
15 variance of less than 5 percent from the tensile strength-at-break of the oriented thermoplastic film.

3. The embossed oriented semi-crystalline thermoplastic film of claim 1, wherein the tensile
20 elongation-at-break of the embossed oriented thermoplastic film has a variance of less than 5 percent from the tensile elongation-at-break of the oriented thermoplastic film.

4. The embossed oriented semi-crystalline thermoplastic film of claim 1, wherein the oriented semi-
25 crystalline thermoplastic film is biaxially oriented.

5. The embossed oriented semi-crystalline thermoplastic film of claim 4, wherein the oriented semi-crystalline thermoplastic film comprises a biaxially oriented isotactic polypropylene.

60557-6245

6. The embossed oriented semi-crystalline thermoplastic film of claim 1, wherein the oriented semi-crystalline thermoplastic film comprises a polymer selected from the group of polyethylene, polypropylene,
5 poly(ethylene/propylene), poly(ethylene/1-butylene), poly(propylene/1-butylene), poly(ethylene/propylene/1-butylene), poly(polyethylene terephthalate), poly(polyethylene butyrate), poly(polyethylene naphthalate), and mixtures thereof.
- 10 7. The embossed oriented semi-crystalline thermoplastic film of claim 1, wherein the oriented semi-crystalline thermoplastic film comprises a polymer selected from the group of linear-low-density polyethylene, high-density polyethylene, ultra-high-molecular-weight
15 polyethylene, isotactic polypropylene, blends of isotactic polypropylene and substantially syndiotactic polypropylene and blends of isotactic polypropylene and polyethylene.
8. The embossed oriented thermoplastic film of any one of claims 1 to 7, on which the embossments are selected
20 from the following geometric patterns: four-sided square pyramids, truncated four-sided square pyramids, cones, straight lines and curved lines.
9. A layered construction comprising the oriented, semi-crystalline thermoplastic film of any one of claims 1
25 to 8.
10. The layered construction of claim 9, further comprising an adhesive layer on at least a portion of at least one major surface of the oriented thermoplastic film.
11. A method of making an embossed semi-crystalline
30 oriented thermoplastic film comprising:

60557-6245

providing an oriented thermoplastic film having first and second major surfaces;

softening at least one of the first and second major surfaces to produce a softened surface;

5 embossing the softened surface to produce an embossed oriented thermoplastic film;

cooling the embossed oriented thermoplastic film;

wherein the tensile strength-at-break and tensile elongation-at-break of the embossed oriented thermoplastic
10 film are substantially the same as the tensile strength-at-break and tensile elongation-at-break of the oriented thermoplastic film before embossing.

12. The method of claim 11, wherein the combined steps of softening, embossing, and cooling occur in less than one
15 second.

13. The method of claim 11 or 12, wherein the softening step is carried out by flame heating.

14. The method of any one of claims 11 to 13, wherein the oriented thermoplastic film comprises a polymer selected
20 from linear-low-density polyethylene, high-density polyethylene, ultra-high-molecular weight polyethylene, isotactic polypropylene, blends of isotactic polypropylene and substantially syndiotactic polypropylene and blends of isotactic polypropylene and polyethylene.

25 15. The method of claim 14, wherein the oriented thermoplastic film is a biaxially oriented isotactic polypropylene.

60557-6245

16. The method of any one of claims 11 to 13 and 15, wherein the film provided in the first step is a layered construction comprising an oriented thermoplastic film having a major surface.

SMART & BIGGAR

OTTAWA, CANADA

PATENT AGENTS

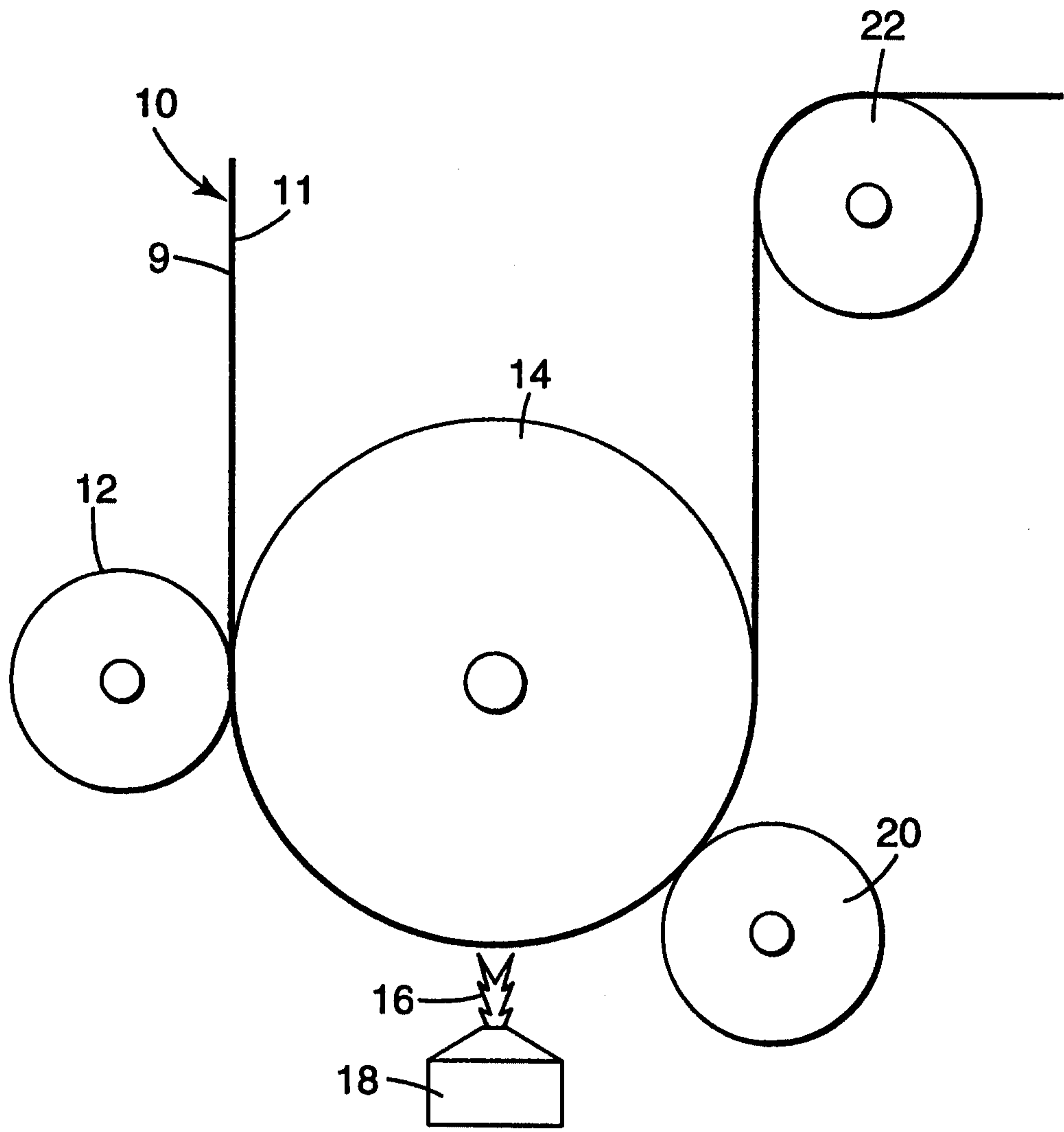
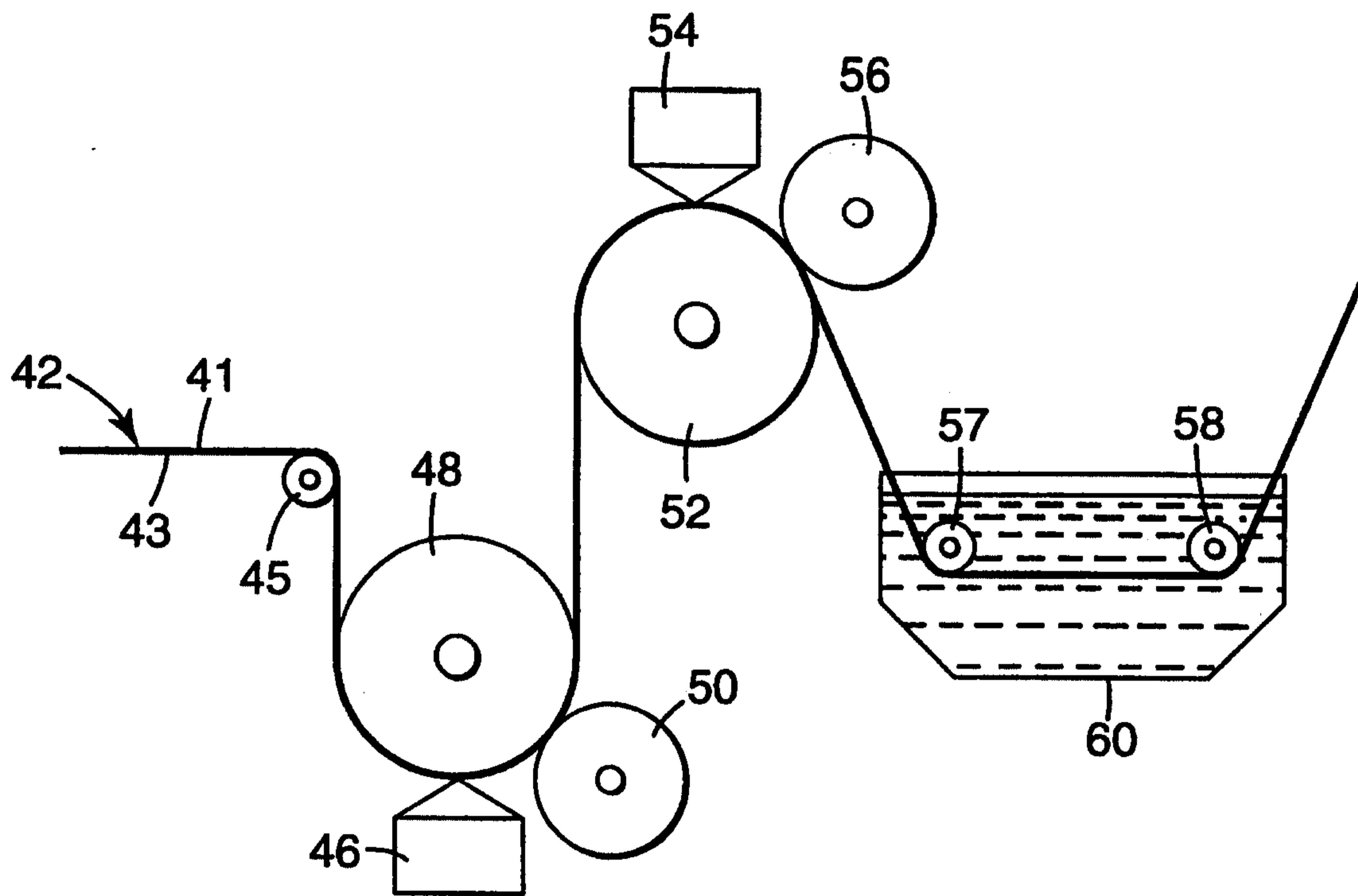

Fig. 1

**Fig. 2**

