



(12) **EUROPEAN PATENT APPLICATION**

(43) Date of publication:
17.06.2015 Bulletin 2015/25

(51) Int Cl.:
E21B 49/08 (2006.01)

(21) Application number: **14200641.0**

(22) Date of filing: **05.02.2008**

(84) Designated Contracting States:
FR GB NO
 Designated Extension States:
AL BA MK RS

- **Zeller, Vincent P.**
Flower Mound, TX Texas 75028 (US)
- **MacPhail, Chuck**
Little Elm, TX Texas 75068 (US)
- **Perkins, Don H.**
Allen, TX Texas 75013 (US)

(30) Priority: **06.02.2007 US 702810**

(62) Document number(s) of the earlier application(s) in accordance with Art. 76 EPC:
08250413.5 / 1 956 185

(74) Representative: **Bennett, Adrian Robert J. et al**
A.A. Thornton & Co.
10 Old Bailey
London EC4M 7NG (GB)

(71) Applicant: **HALLIBURTON ENERGY SERVICES, INC.**
Dallas, TX 75381-9052 (US)

Remarks:

This application was filed on 30-12-2014 as a divisional application to the application mentioned under INID code 62.

(72) Inventors:
 • **Irani, Cyrus**
Houston, TX Texas 77095 (US)

(54) **Single phase fluid sampling apparatus and method for use of same**

(57) An apparatus (300) for obtaining a fluid sample in a subterranean well includes a housing (302) having a sample chamber (314) defined therein. The sample chamber (314) is selectively in fluid communication with the exterior of the housing (302) and is operable to receive the fluid sample therefrom. A debris trap piston (318) is slidably disposed within the housing (302). The debris trap piston (318) includes a debris chamber (326). Responsive to the fluid sample entering the sample chamber (314), the debris trap piston (318) receives a first portion of the fluid sample in the debris chamber (326) then displaces relative to the housing (302) to expand the sample chamber (314).

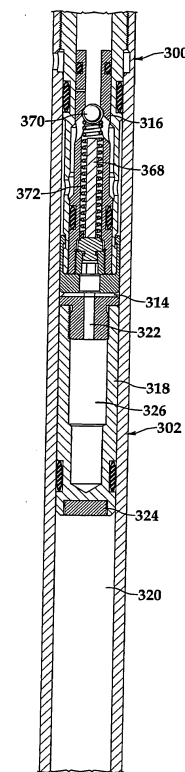

Fig.9B

Description

[0001] This invention relates, in general, to testing and evaluation of subterranean formation fluids and, in particular to, a single phase fluid sampling apparatus for obtaining multiple fluid samples and maintaining the samples near reservoir pressure via a common pressure source during retrieval from the wellbore and storage on the surface.

[0002] Without limiting the scope of the present invention, its background is described with reference to testing hydrocarbon formations, as an example.

[0003] It is well known in the subterranean well drilling and completion art to perform tests on formations intersected by a wellbore. Such tests are typically performed in order to determine geological or other physical properties of the formation and fluids contained therein. For example, parameters such as permeability, porosity, fluid resistivity, temperature, pressure and bubble point may be determined. These and other characteristics of the formation and fluid contained therein may be determined by performing tests on the formation before the well is completed.

[0004] One type of testing procedure that is commonly performed is to obtain a fluid sample from the formation to, among other things, determine the composition of the formation fluids. In this procedure, it is important to obtain a sample of the formation fluid that is representative of the fluids as they exist in the formation. In a typical sampling procedure, a sample of the formation fluids may be obtained by lowering a sampling tool having a sampling chamber into the wellbore on a conveyance such as a wireline, slick line, coiled tubing, jointed tubing or the like. When the sampling tool reaches the desired depth, one or more ports are opened to allow collection of the formation fluids. The ports may be actuated in variety of ways such as by electrical, hydraulic or mechanical methods. Once the ports are opened, formation fluids travel through the ports and a sample of the formation fluids is collected within the sampling chamber of the sampling tool. After the sample has been collected, the sampling tool may be withdrawn from the wellbore so that the formation fluid sample may be analyzed.

[0005] It has been found, however, that as the fluid sample is retrieved to the surface, the temperature of the fluid sample decreases causing shrinkage of the fluid sample and a reduction in the pressure of the fluid sample. These changes can cause the fluid sample to approach or reach saturation pressure creating the possibility of asphaltene deposition and flashing of entrained gasses present in the fluid sample. Once such a process occurs, the resulting fluid sample is no longer representative of the fluids present in the formation. Therefore, a need has arisen for an apparatus and method for obtaining a fluid sample from a formation without degradation of the sample during retrieval of the sampling tool from the wellbore. A need has also arisen for such an apparatus and method that are capable of maintaining the

integrity of the fluid sample during storage on the surface.

[0006] The present invention provides a downhole tool as recited in the appended independent claim 1.

[0007] Further features of the present invention are provided as recited in the appended dependent claims.

[0008] Apparatus is hereinafter described as recited in the appended Statement 1 (not claim) found at the end of this description.

[0009] The apparatus may further comprise a check valve disposed in an inlet portion of the debris trap piston, the check valve operable to retain the first portion of the fluid sample in the debris chamber. The debris trap piston may further comprise a first piston section and a second piston section that is slidable relative to the first piston section such that the debris chamber is expandable responsive to the fluid sample entering the debris chamber. The apparatus further comprise an engagement device disposed between the first piston section and the second piston section, the engagement device preventing additional movement of the first piston section relative to the second piston section after expanding the debris chamber to a preselected volume.

[0010] A method is hereinafter described as recited in the appended. Statement 5 (not claim) found at the end of this description.

[0011] The method may further comprise the step of retaining the first portion of the fluid sample in the debris chamber using a check valve disposed in an inlet portion of the debris trap piston. The method may further comprise the step of expanding the debris chamber responsive to the fluid sample entering the debris chamber by sliding a first piston section relative to a second piston section. The method may further comprise preventing additional movement of the first piston section relative to the second piston section after expanding the debris chamber to a preselected volume.

[0012] A downhole tool is hereinafter described as recited in the appended Statement 8 (not claim) found at the end of this description.

[0013] The needle may have an outer surface selected from one of a smooth outer surface, a fluted outer surface, a channeled outer surface and a knurled outer surface. The piston may be displaced relative to the valving assembly and the housing. The valving assembly may further comprise a check valve that allows fluid flow in a first direction and prevents fluid flow in a second direction through the valving assembly once the valving assembly is actuated. The downhole tool may be an apparatus for obtaining a fluid sample in a subterranean well. The pressure disk may further comprise a rupture disk. The downhole tool may further comprise a magnetic locator operably associated with the piston, the magnetic locator providing a reference to determine the level of displacement of the piston.

[0014] Described hereinafter is a single phase fluid sampling apparatus and a method for obtaining fluid samples from a formation without the occurrence of phase change degradation of the fluid samples during the col-

lection of the fluid samples or retrieval of the sampling apparatus from the wellbore. In addition, the sampling apparatus and method of the present invention are capable of maintaining the integrity of the fluid samples during storage on the surface.

[0015] Described hereinafter is an apparatus for obtaining a plurality of fluid samples in a subterranean well that includes a carrier, a plurality of sampling chambers and a pressure source. In one embodiment, the pressure source is selectively in fluid communication with at least two sampling chambers thereby serving as a common pressure source to pressurize fluid samples obtained in the at least two sampling chambers. In another embodiment, the carrier has a longitudinally extending internal fluid passageway forming a smooth bore and a plurality of externally disposed chamber receiving slots. Each of the sampling chambers is positioned in one of the chamber receiving slots of the carrier. The pressure source is selectively in fluid communication with each of the sampling chambers such that the pressure source is operable to pressurize each of the sampling chambers after the fluid samples are obtained.

[0016] Described hereinafter is a method for obtaining a plurality of fluid samples in a subterranean well. The method includes the steps of positioning a fluid sampler in the well, obtaining a fluid sample in each of a plurality of sampling chambers of the fluid sampler and pressurizing each of the fluid samples using a pressure source of the fluid sampler that is in fluid communication with each of the sampling chambers.

[0017] Described hereinafter is directed to an apparatus for obtaining a fluid sample in a subterranean well. The apparatus includes a housing having a sample chamber defined therein. The sample chamber is selectively in fluid communication with the exterior of the housing and is operable to receive the fluid sample therefrom. A debris trap piston is slidably disposed within the housing. The debris trap piston includes a debris chamber and, responsive to the fluid sample entering the sample chamber, the debris trap piston receives a first portion of the fluid sample in the debris chamber then displaces relative to the housing to expand the sample chamber.

[0018] In one embodiment, the debris trap piston includes a passageway having a cross sectional area that is smaller than the cross sectional area of the debris chamber. In this embodiment, the first portion of the fluid sample passes from the sample chamber through the passageway to enter the debris chamber. Also in this embodiment, the first portion of the fluid sample is retained in the debris chamber due to pressure from the sample chamber applied to the debris chamber through the passageway. Alternatively or additionally, a check valve may be disposed in an inlet portion of the debris trap piston to retain the first portion of the fluid sample in the debris chamber.

[0019] In another embodiment, the debris trap piston may include a first piston section and a second piston section that is slidable relative to the first piston section

such that the debris chamber is expandable responsive to the fluid sample entering the debris chamber. In this embodiment, an engagement device may be disposed between the first piston section and the second piston section to prevent additional movement of the first piston section relative to the second piston section after expanding the debris chamber to a preselected volume.

[0020] Described hereinafter is a method for obtaining a fluid sample in a subterranean well. The method includes the steps of disposing a sampling chamber within the subterranean well, actuating the sampling chamber such that a sample chamber within the sampling chamber is in fluid communication with the exterior of the sampling chamber, receiving a first portion of the fluid sample in a debris chamber of a debris trap piston slidably disposed within the sampling chamber, displacing the debris trap piston within the sampling chamber to expand the sample chamber and receiving the remainder of the fluid sample in the sample chamber.

[0021] The method may also include passing the first portion of the fluid sample through the sample chamber and through a passageway of the debris trap piston before entering the debris chamber and retaining the first portion of the fluid sample in the debris chamber by applying pressure from the sample chamber to the debris chamber through the passageway. Additionally or alternatively, a check valve disposed in an inlet portion of the debris trap piston may be used to retain the first portion of the fluid sample in the debris chamber.

[0022] In certain embodiments, the method may include expanding the debris chamber responsive to the fluid sample entering the debris chamber by sliding a first piston section relative to a second piston section and preventing additional movement of the first piston section relative to the second piston section after expanding the debris chamber to a preselected volume.

[0023] Described hereinafter is a downhole tool including a housing having a longitudinal passageway. A piston, including a piercing assembly, is disposed within the longitudinal passageway. A valving assembly is also disposed within the longitudinal passageway. The valving assembly includes a rupture disk that is initially operable to maintain a differential pressure thereacross. The valving assembly is actuated by longitudinally displacing the piston relative to the valving assembly such that at least a portion of the piercing assembly travels through the rupture disk, thereby allowing fluid flow therethrough.

[0024] In one embodiment, the piercing assembly includes a piercing assembly body and a needle that is held within the piercing assembly body by compression. In this embodiment, the needle has a sharp point that travels through the rupture disk. In addition, the needle may have a smooth outer surface, a fluted outer surface, a channeled outer surface or a knurled outer surface. In certain embodiments, the valving assembly may include a check valve that allows fluid flow in a first direction and prevents fluid flow in a second direction through the valving assembly once the valving assembly is actuated by

the piercing assembly.

[0025] For a more complete understanding of the present invention, including its features and advantages, reference is now made to the detailed description of the invention, taken in conjunction with the accompanying drawings in which like numerals identify like parts and in which:

Figure 1 is a schematic illustration of a fluid sampler system embodying principles of the present invention;

Figures 2A-H are cross-sectional views of successive axial portions of one embodiment of a sampling section of a sampler embodying principles of the present invention;

Figures 3A-E are cross-sectional views of successive axial portions of actuator, carrier and pressure source sections of a sampler embodying principles of the present invention;

Figure 4 is a cross-sectional view of the pressure source section of figure 3C taken along line 4-4;

Figure 5 is a cross-sectional view of the actuator section of figure 3A taken along line 5-5;

Figure 6 is a schematic view of an alternate actuating method for a sampler embodying principles of the present invention;

Figure 7 is a schematic illustration of an alternate embodiment of a fluid sampler embodying principles of the present invention;

Figure 8 is a cross-sectional view of the fluid sampler of figure 7 taken along line 8-8; and

Figures 9A-G are cross-sectional views of successive axial portions of another embodiment of a sampling section of a sampler embodying principles of the present invention.

[0026] While the making and using of various embodiments of the present invention are discussed in detail below, it should be appreciated that the present invention provides many applicable inventive concepts which can be embodied in a wide variety of specific contexts. The specific embodiments discussed herein are merely illustrative of specific ways to make and use the invention, and do not delimit the scope of the invention.

[0027] Referring initially to figure 1, therein is representatively illustrated a fluid sampler system 10 and associated methods which embody principles of the present invention. A tubular string 12, such as a drill stem test string, is positioned in a wellbore 14. An internal flow passage 16 extends longitudinally through tubular string 12.

[0028] A fluid sampler 18 is interconnected in tubular string 12. Also, preferably included in tubular string 12 are a circulating valve 20, a tester valve 22 and a choke 24. Circulating valve 20, tester valve 22 and choke 24 may be of conventional design. It should be noted, however, by those skilled in the art that it is not necessary for tubular string 12 to include the specific combination

or arrangement of equipment described herein. It is also not necessary for sampler 18 to be included in tubular string 12 since, for example, sampler 18 could instead be conveyed through flow passage 16 using a wireline, slickline, coiled tubing, downhole robot or the like. Although wellbore 14 is depicted as being cased and cemented, it could alternatively be uncased or open hole.

[0029] In a formation testing operation, tester valve 22 is used to selectively permit and prevent flow through passage 16. Circulating valve 20 is used to selectively permit and prevent flow between passage 16 and an annulus 26 formed radially between tubular string 12 and wellbore 14. Choke 24 is used to selectively restrict flow through tubular string 12. Each of valves 20, 22 and choke 24 may be operated by manipulating pressure in annulus 26 from the surface, or any of them could be operated by other methods if desired.

[0030] Choke 24 may be actuated to restrict flow through passage 16 to minimize wellbore storage effects due to the large volume in tubular string 12 above sampler 18. When choke 24 restricts flow through passage 16, a pressure differential is created in passage 16, thereby maintaining pressure in passage 16 at sampler 18 and reducing the drawdown effect of opening tester valve 22. In this manner, by restricting flow through choke 24 at the time a fluid sample is taken in sampler 18, the fluid sample may be prevented from going below its bubble point, i.e., the pressure below which a gas phase begins to form in a fluid phase. Circulating valve 20 permits hydrocarbons in tubular string 12 to be circulated out prior to retrieving tubular string 12. As described more fully below, circulating valve 20 also allows increased weight fluid to be circulated into wellbore 14.

[0031] Even though figure 1 depicts a vertical well, it should be noted by one skilled in the art that the fluid sampler of the present invention is equally well-suited for use in deviated wells, inclined wells or horizontal wells. As such, the use of directional terms such as above, below, upper, lower, upward, downward and the like are used in relation to the illustrative embodiments as they are depicted in the figures, the upward direction being toward the top of the corresponding figure and the downward direction being toward the bottom of the corresponding figure.

[0032] Referring now to figures 2A-2H and 3A-3E, a fluid sampler including an exemplary fluid sampling chamber and an exemplary carrier having a pressure source coupled thereto for use in obtaining a plurality of fluid samples that embodies principles of the present invention is representatively illustrated and generally designated 100. Fluid sampler 100 includes a plurality of the sampling chambers such sampling chamber 102 as depicted in figure 2. Each of the sampling chambers 102 is coupled to a carrier 104 that also includes an actuator 106 and a pressure source 108 as depicted in figure 3.

[0033] As described more fully below, a passage 110 in an upper portion of sampling chamber 102 (see figure 2A) is placed in communication with a longitudinally ex-

tending internal fluid passageway 112 formed completely through fluid sampler 100 (see figure 3) when the fluid sampling operation is initiated using actuator 106. Passage 112 becomes a portion of passage 16 in tubular string 12 (see figure 1) when fluid sampler 100 is interconnected in tubular string 12. As such, internal fluid passageway 112 provides a smooth bore through fluid sampler 100. Passage 110 in the upper portion of sampling chamber 102 is in communication with a sample chamber 114 via a check valve 116. Check valve 116 permits fluid to flow from passage 110 into sample chamber 114, but prevents fluid from escaping from sample chamber 114 to passage 110.

[0034] A debris trap piston 118 separates sample chamber 114 from a meter fluid chamber 120. When a fluid sample is received in sample chamber 114, piston 118 is displaced downwardly. Prior to such downward displacement of piston 118, however, piston section 122 is displaced downwardly relative to piston section 124. In the illustrated embodiment, as fluid flows into sample chamber 114, an optional check valve 128 permits the fluid to flow into debris chamber 126. The resulting pressure differential across piston section 122 causes piston section 122 to displace downward, thereby expanding debris chamber 126.

[0035] Eventually, piston section 122 will displace downward sufficiently far for a snap ring, C-ring, spring-loaded lugs, dogs or other type of engagement device 130 to engage a recess 132 formed on piston section 124. Once engagement device 130 has engaged recess 132, piston sections 122, 124 displace downwardly together to expand sample chamber 114. The fluid received in debris chamber 126 is prevented from escaping back into sample chamber 114 by check valve 128 in embodiments that include check valve 128. In this manner, the fluid initially received into sample chamber 114 is trapped in debris chamber 126. This initially received fluid is typically laden with debris, or is a type of fluid (such as mud) which it is not desired to sample. Debris chamber 126 thus permits this initially received fluid to be isolated from the fluid sample later received in sample chamber 114.

[0036] Meter fluid chamber 120 initially contains a metering fluid, such as a hydraulic fluid, silicone oil or the like. A flow restrictor 134 and a check valve 136 control flow between chamber 120 and an atmospheric chamber 138 that initially contains a gas at a relatively low pressure such as air at atmospheric pressure. A collapsible piston assembly 140 in chamber 138 includes a prong 142 which initially maintains another check valve 144 off seat, so that flow in both directions is permitted through check valve 144 between chambers 120, 138. When elevated pressure is applied to chamber 138, however, as described more fully below, piston assembly 140 collapses axially, and prong 142 will no longer maintain check valve 144 off seat, thereby preventing flow from chamber 120 to chamber 138.

[0037] A floating piston 146 separates chamber 138

from another atmospheric chamber 148 that initially contains a gas at a relatively low pressure such as air at atmospheric pressure. A spacer 150 is attached to piston 146 and limits downward displacement of piston 146. Spacer 150 is also used to contact a stem 152 of a valve 154 to open valve 154. Valve 154 initially prevents communication between chamber 148 and a passage 156 in a lower portion of sampling chamber 102. In addition, a check valve 158 permits fluid flow from passage 156 to chamber 148, but prevents fluid flow from chamber 148 to passage 156.

[0038] As mentioned above, one or more of the sampling chambers 102 and preferably nine of sampling chambers 102 are installed within exteriorly disposed chamber receiving slots 159 that circumscribe internal fluid passageway 112 of carrier 104. A seal bore 160 (see figure 3B) is provided in carrier 104 for receiving the upper portion of sampling chamber 102 and another seal bore 162 (see figure 3C) is provided for receiving the lower portion of sampling chamber 102. In this manner, passage 110 in the upper portion of sampling chamber 102 is placed in sealed communication with a passage 164 in carrier 104, and passage 156 in the lower portion of sampling chamber 102 is placed in sealed communication with a passage 166 in carrier 104.

[0039] In addition to the nine sampling chambers 102 installed within carrier 104, a pressure and temperature gauge/recorder (not shown) of the type known to those skilled in the art can also be received in carrier 104 in a similar manner. For example, seal bores 168, 170 in carrier 104 may be for providing communication between the gauge/recorder and internal fluid passageway 112. Note that, although seal bore 170 depicted in figure 3C is in communication with passage 172, preferably if seal bore 170 is used to accommodate a gauge/recorder, then a plug is used to isolate the gauge/recorder from passage 172. Passage 172 is, however, in communication with passage 166 and the lower portion of each sampling chamber 102 installed in a seal bore 162 and thus serves as a manifold for fluid sampler 100. If a sampling chamber 102 or gauge/recorder is not installed in one or more of the seal bores 160, 162, 168, 170 then a plug will be installed to prevent flow therethrough.

[0040] Passage 172 is in communication with chamber 174 of pressure source 108. Chamber 174 is in communication with chamber 176 of pressure source 108 via a passage 178. Chambers 174, 176 initially contain a pressurized fluid, such as a compressed gas or liquid. Preferably, compressed nitrogen at between about 7,000 psi and 12,000 psi is used to precharge chambers 174, 176, but other fluids or combinations of fluids and/or other pressures both higher and lower could be used, if desired. Even though figure 3 depicts pressure source 108 as having two compressed fluid chambers 174, 176, it should be understood by those skilled in the art that pressure source 108 could have any number of chambers both higher and lower than two that are in communication with one another to provide the required pressure source.

As best seen in figure 4, a cross-sectional view of pressure source 108 is illustrated, showing a fill valve 180 and a passage 182 extending from fill valve 180 to chamber 174 for supplying the pressurized fluid to chambers 174, 176 at the surface prior to running fluid sampler 100 downhole.

[0041] As best seen in figures 3A and 5, actuator 106 includes multiple valves 184, 186, 188 and respective multiple rupture disks 190, 192, 194 to provide for separate actuation of multiple groups of sampling chambers 102. In the illustrated embodiment, nine sampling chambers 102 may be used, and these are divided up into three groups of three sampling chambers each. Each group of sampling chambers can be referred to as a sampling chamber assembly. Thus, a valve 184, 186, 188 and a respective rupture disk 190, 192, 194 are used to actuate a group of three sampling chambers 102. For clarity, operation of actuator 106 with respect to only one of the valves 184, 186, 188 and its respective one of the rupture disks 190, 192, 194 is described below. Operation of actuator 106 with respect to the other valves and rupture disks is similar to that described below.

[0042] Valve 184 initially isolates passage 164, which is in communication with passages 110 in three of the sampling chambers 102 via passage 196, from internal fluid passage 112 of fluid sampler 100. This isolates sample chamber 114 in each of the three sampling chambers 102 from passage 112. When it is desired to receive a fluid sample into each of the sample chambers 114 of the three sampling chambers 102, pressure in annulus 26 is increased a sufficient amount to rupture the disk 190. This permits pressure in annulus 26 to shift valve 184 upward, thereby opening valve 184 and permitting communication between passage 112 and passages 196, 164.

[0043] Fluid from passage 112 then enters passage 110 in the upper portion of each of the three sampling chambers 102. For clarity, the operation of only one of the sampling chambers 102 after receipt of a fluid sample therein is described below. The fluid flows from passage 110 through check valve 116 to sample chamber 114. An initial volume of the fluid is trapped in debris chamber 126 of piston 118 as described above. Downward displacement of the piston section 122, and then the combined piston sections 122, 124, is slowed by the metering fluid in chamber 120 flowing through restrictor 134. This prevents pressure in the fluid sample received in sample chamber 114 from dropping below its bubble point.

[0044] As piston 118 displaces downward, the metering fluid in chamber 120 flows through restrictor 134 into chamber 138. At this point, prong 142 maintains check valve 144 off seat. The metering fluid received in chamber 138 causes piston 146 to displace downward. Eventually, spacer 150 contacts stem 152 of valve 154 which opens valve 154. Opening of valve 154 permits pressure in pressure source 108 to be applied to chamber 148. Pressurization of chamber 148 also results in pressure being applied to chambers 138, 120 and thus to sample cham-

ber 114. This is due to the fact that passage 156 is in communication with passages 166, 172 (see figure 3C) and, thus, is in communication with the pressurized fluid from pressure source 108.

[0045] When the pressure from pressure source 108 is applied to chamber 138, piston assembly 140 collapses and prong 142 no longer maintains check valve 144 off seat. Check valve 144 then prevents pressure from escaping from chamber 120 and sample chamber 114. Check valve 116 also prevents escape of pressure from sample chamber 114. In this manner, the fluid sample received in sample chamber 114 is pressurized.

[0046] In the illustrated embodiment of fluid sampler 100, multiple sampling chambers 102 are actuated by rupturing disk 190, since valve 184 is used to provide selective communication between passage 112 and passages 110 in the upper portions of multiple sampling chambers 102. Thus, multiple sampling chambers 102 simultaneously receive fluid samples therein from passage 112.

[0047] In a similar manner, when rupture disk 192 is ruptured, an additional group of multiple sampling chambers 102 will receive fluid samples therein, and when the rupture disk 194 is ruptured a further group of multiple sampling chambers 102 will receive fluid samples therein. Rupture disks 184, 186, 188 may be selected so that they are ruptured sequentially at different pressures in annulus 26 or they may be selected so that they are ruptured simultaneously, at the same pressure in annulus 26.

[0048] Another important feature of fluid sampler 100 is that the multiple sampling chambers 102, nine in the illustrated example, share the same pressure source 108. That is, pressure source 108 is in communication with each of the multiple sampling chambers 102. This feature provides enhanced convenience, speed, economy and safety in the fluid sampling operation. In addition to sharing a common pressure source downhole, the multiple sampling chambers 102 of fluid sampler 100 can also share a common pressure source on the surface. Specifically, once all the samples are obtained and pressurized downhole, fluid sampler 100 is retrieved to the surface. Even though certain cooling of the samples will take place, the common pressure source maintains the samples at a suitable pressure to prevent any phase change degradation. Once on the surface, the sample may remain in the multiple sampling chambers 102 for a considerable time during which temperature conditions may fluctuate. Accordingly, a surface pressure source, such a compressor or a pump, may be used to supercharge the sampling chambers 102. This supercharging process allows multiple sampling chambers 102 to be further pressurized at the same time with sampling chambers 102 remaining in carrier 104 or after sampling chambers 102 have been removed from carrier 104.

[0049] Note that, although actuator 106 is described above as being configured to permit separate actuation of three groups of sampling chambers 102, with each

group including three of the sampling chambers 102, it will be appreciated that any number of sampling chambers 102 may be used, sampling chambers 102 may be included in any number of groups (including one), each group could include any number of sampling chambers 102 (including one), different groups can include different numbers of sampling chambers 102 and it is not necessary for sampling chambers 102 to be separately grouped at all.

[0050] Referring now to figure 6, an alternate actuating method for fluid sampler 100 is representatively and schematically illustrated. Instead of using increased pressure in annulus 26 to actuate valves 184, 186, 188, a control module 198 included in fluid sampler 100 may be used to actuate valves 184, 186, 188. For example, a telemetry receiver 199 may be connected to control module 198. Receiver 199 may be any type of telemetry receiver, such as a receiver capable of receiving acoustic signals, pressure pulse signals, electromagnetic signals, mechanical signals or the like. As such, any type of telemetry may be used to transmit signals to receiver 199.

[0051] When control module 198 determines that an appropriate signal has been received by receiver 199, control module 198 causes a selected one or more of valves 184, 186, 188 to open, thereby causing a plurality of fluid samples to be taken in fluid sampler 100. Valves 184, 186, 188 may be configured to open in response to application or release of electrical current, fluid pressure, biasing force, temperature or the like.

[0052] Referring now to figures 7 and 8, an alternate embodiment of a fluid sampler for use in obtaining a plurality of fluid samples that embodies principles of the present invention is representatively illustrated and generally designated 200. Fluid sampler 200 includes an upper connector 202 for coupling fluid sampler 200 to other well tools in the sampler string. Fluid sampler 200 also includes an actuator 204 that operates in a manner similar to actuator 106 described above. Below actuator 204 is a carrier 206 that is of similar construction as carrier 104 described above. Fluid sampler 200 further includes a manifold 208 for distributing fluid pressure. Below manifold 208 is a lower connector 210 for coupling fluid sampler 200 to other well tools in the sampler string.

[0053] Fluid sampler 200 has a longitudinally extending internal fluid passageway 212 formed completely through fluid sampler 200. Passageway 212 becomes a portion of passage 16 in tubular string 12 (see figure 1) when fluid sampler 200 is interconnected in tubular string 12. In the illustrated embodiment, carrier 206 has ten exteriorly disposed chamber receiving slots that circumscribe internal fluid passageway 212. As mentioned above, a pressure and temperature gauge/recorder (not shown) of the type known to those skilled in the art can be received in carrier 206 within one of the chamber receiving slots such as slot 214. The remainder of the slots are used to receive sampling chambers and pressure source chambers.

[0054] In the illustrated embodiment, sampling cham-

bers 216, 218, 220, 222, 224, 226 are respectively received within slots 228, 230, 232, 234, 236, 238. Sampling chambers 216, 218, 220, 222, 224, 226 are of a construction and operate in the manner described above with reference to sampling chamber 102. Pressure source chambers 240, 242, 244 are respectively received within slots 246, 248, 250 in a manner similar to that described above with reference to sampling chamber 102. Pressure source chambers 240, 242, 244 initially contain a pressurized fluid, such as a compressed gas or liquid. Preferably, compressed nitrogen at between about 689 bar (10,000 psi) and 1378 bar (20,000 psi) is used to precharge chambers 240, 242, 244, but other fluids or combinations of fluids and/or other pressures both higher and lower could be used, if desired.

[0055] Actuator 204 includes three valves that operate in a manner similar to valves 184, 186, 188 of actuator 106. Actuator 204 has three rupture disks, one associated with each valve in a manner similar to rupture disks 190, 192, 194 of actuator 106 and one of which is pictured and denoted as rupture disk 252. As described above, each of the rupture disks provides for separate actuation of a group of sampling chambers. In the illustrated embodiment, six sampling chambers are used, and these are divided up into three groups of two sampling chambers each. Associated with each group of two sampling chambers is one pressure source chamber. Specifically, rupture disk 252 is associated with sampling chambers 216, 218 which are also associated with pressure source chamber 240 via manifold 208. In a like manner, the second rupture disk is associated with sampling chambers 220, 222 which are also associated with pressure source chamber 242 via manifold 208. In addition, the third rupture disk is associated with sampling chambers 224, 226 which are also associated with pressure source chamber 244 via manifold 208. In the illustrated embodiment, each rupture disk, valve, pair of sampling chambers, pressure source chamber and manifold section can be referred to as a sampling chamber assembly. Each of the three sampling chamber assemblies operates independently of the other two sampling chamber assemblies. For clarity, the operation of one sampling chamber assembly is described below. Operation of the other two sampling chamber assemblies is similar to that described below.

[0056] The valve associated with rupture disk 252 initially isolates the sample chambers of sampling chambers 216, 218 from internal fluid passageway 212 of fluid sampler 200. When it is desired to receive a fluid sample into each of the sample chambers of sampling chambers 216, 218, pressure in annulus 26 is increased a sufficient amount to rupture the disk 252. This permits pressure in annulus 26 to shift the associated valve upward in a manner described above, thereby opening the valve and permitting communication between passageway 212 and the sample chambers of sampling chambers 216, 218.

[0057] As described above, fluid from passageway 212 enters a passage in the upper portion of each of the sampling chambers 216, 218 and passes through an optional

check valve to the sample chambers. An initial volume of the fluid is trapped in a debris chamber as described above. Downward displacement of the debris piston is slowed by the metering fluid in another chamber flowing through a restrictor. This prevents pressure in the fluid sample received in the sample chambers from dropping below its bubble point.

[0058] As the debris piston displaces downward, the metering fluid flows through the restrictor into a lower chamber causing a piston to displace downward. Eventually, a spacer contacts a stem of a lower valve which opens the valve and permits pressure from pressure source chamber 240 to be applied to the lower chamber via manifold 208. Pressurization of the lower chamber also results in pressure being applied to the sample chambers of sampling chambers 216, 218.

[0059] As described above, when the pressure from pressure source chamber 240 is applied to the lower chamber, a piston assembly collapses and a prong no longer maintains a check valve off seat, which prevents pressure from escaping from the sample chambers. The upper check valve also prevents escape of pressure from the sample chamber. In this manner, the fluid samples received in the sample chambers are pressurized.

[0060] In the illustrated embodiment of fluid sampler 200, two sampling chambers 216, 218 are actuated by rupturing disk 252, since the valve associated therewith is used to provide selective communication between passageway 212 the sample chambers of sampling chambers 216, 218. Thus, both sampling chambers 216, 218 simultaneously receive fluid samples therein from passageway 212.

[0061] In a similar manner, when the other rupture disks are ruptured, additional groups of two sampling chambers (sampling chambers 220, 222 and sampling chambers 224, 226) will receive fluid samples therein and the fluid samples obtained therein will be pressurized by pressure sources 242, 244, respectively. The rupture disks may be selected so that they are ruptured sequentially at different pressures in annulus 26 or they may be selected so that they are ruptured simultaneously, at the same pressure in annulus 26.

[0062] One of the important features of fluid sampler 200 is that the multiple sampling chambers, two in the illustrated example, share a common pressure source. That is, each pressure source is in communication with multiple sampling chambers. This feature provides enhanced convenience, speed, economy and safety in the fluid sampling operation. In addition to sharing a common pressure source downhole, multiple sampling chambers of fluid sampler 200 can also share a common pressure source on the surface. Specifically, once all the samples are obtained and pressurized downhole, fluid sampler 200 is retrieved to the surface. Even though certain cooling of the samples will take place, the common pressure source maintains the samples at a suitable pressure to prevent any phase change degradation. Once on the surface, the samples may remain in the multiple sampling

chambers for a considerable time during which temperature conditions may fluctuate. Accordingly, a surface pressure source, such a compressor or a pump, may be used to supercharge the sampling chambers. This supercharging process allows multiple sampling chambers to be further pressurized at the same time with the sampling chambers remaining in carrier 206 or after sampling chambers have been removed from carrier 206.

[0063] It should be understood by those skilled in the art that even though fluid sampler 200 has been described as having one pressure source chamber in communication with two sampling chambers via manifold 208, other numbers of pressure source chambers may be in communication with other numbers of sampling chambers with departing from the principles of the present invention. For example, in certain embodiments, one pressure source chamber could communicate pressure to three, four or more sampling chambers. Likewise, two or more pressure source chambers could act as a common pressure source to a single sampling chamber or to a plurality of sampling chambers. Each of these embodiments may be enabled by making the appropriate adjustments to manifold 208 such that the desired pressure source chambers and the desired sampling chambers are properly communicated to one another.

[0064] Referring now to figures 9A-9G and with reference to figures 3A-3E, an alternate fluid sampling chamber for use in a fluid sampler including an exemplary carrier having a pressure source coupled thereto for use in obtaining a plurality of fluid samples that embodies principles of the present invention is representatively illustrated and generally designated 300. Each of the sampling chambers 300 is coupled to a carrier 104 that also includes an actuator 106 and a pressure source 108 as depicted in figure 3.

[0065] As described more fully below, a passage 310 in an upper portion of sampling chamber 300 (see figure 9A) is placed in communication with a longitudinally extending internal fluid passageway 112 formed completely through the fluid sampler (see figure 3) when the fluid sampling operation is initiated using actuator 106. Passage 112 becomes a portion of passage 16 in tubular string 12 (see figure 1) when the fluid sampler is interconnected in tubular string 12. As such, internal fluid passageway 112 provides a smooth bore through the fluid sampler. Passage 310 in the upper portion of sampling chamber 300 is in communication with a sample chamber 314 via a check valve 316. Check valve 316 permits fluid to flow from passage 310 into sample chamber 314, but prevents fluid from escaping from sample chamber 314 to passage 310.

[0066] A debris trap piston 318 is disposed within housing 302 and separates sample chamber 314 from a meter fluid chamber 320. When a fluid sample is received in sample chamber 314, debris trap piston 318 is displaced downwardly relative to housing 302 to expand sample chamber 314. Prior to such downward displacement of debris trap piston 318, however, fluid flows through sam-

ple chamber 314 and passageway 322 of piston 318 into debris chamber 326 of debris trap piston 318. The fluid received in debris chamber 326 is prevented from escaping back into sample chamber 314 due to the relative cross sectional areas of passageway 322 and debris chamber 326 as well as the pressure maintained on debris chamber 326 from sample chamber 314 via passageway 322. An optional check valve (not pictured) may be disposed within passageway 322 if desired. Such a check valve would operate in the manner described above with reference to check valve 128 in figure 2B. In this manner, the fluid initially received into sample chamber 314 is trapped in debris chamber 326. Debris chamber 326 thus permits this initially received fluid to be isolated from the fluid sample later received in sample chamber 314. Debris trap piston 318 includes a magnetic locator 324 used as a reference to determine the level of displacement of debris trap piston 318 and thus the volume within sample chamber 314 after a sample has been obtained.

[0067] Meter fluid chamber 320 initially contains a metering fluid, such as a hydraulic fluid, silicone oil or the like. A flow restrictor 334 and a check valve 336 control flow between chamber 320 and an atmospheric chamber 338 that initially contains a gas at a relatively low pressure such as air at atmospheric pressure. A collapsible piston assembly 340 includes a prong 342 which initially maintains check valve 344 off seat, so that flow in both directions is permitted through check valve 344 between chambers 320, 338. When elevated pressure is applied to chamber 338, however, as described more fully below, piston assembly 340 collapses axially, and prong 342 will no longer maintain check valve 344 off seat, thereby preventing flow from chamber 320 to chamber 338.

[0068] A piston 346 disposed within housing 302 separates chamber 338 from a longitudinally extending atmospheric chamber 348 that initially contains a gas at a relatively low pressure such as air at atmospheric pressure. Piston 346 includes a magnetic locator 347 used as a reference to determine the level of displacement of piston 346 and thus the volume within chamber 338 after a sample has been obtained. Piston 346 included a piercing assembly 350 at its lower end. In the illustrated embodiment, piercing assembly 350 is threadably coupled to piston 346 which creates a compression connection between a piercing assembly body 352 and a needle 354. Alternatively, needle 354 may be coupled to piercing assembly body 352 via threading, welding, friction or other suitable technique. Needle 354 has a sharp point at its lower end and may have a smooth outer surface or may have an outer surface that is fluted, channeled, knurled or otherwise irregular. As discussed more fully below, needle 354 is used to actuate the pressure delivery subsystem of the fluid sampler when piston 346 is sufficiently displaced relative to housing 302.

[0069] Below atmospheric chamber 348 and disposed within the longitudinal passageway of housing 302 is a valving assembly 356. Valving assembly 356 includes a

pressure disk holder 358 that receives a pressure disk therein that is depicted as rupture disk 360, however, other types of pressure disks that provide a seal, such as a metal-to-metal seal, with pressure disk holder 358 could also be used including a pressure membrane or other piercable member. Rupture disk 360 is held within pressure disk holder 358 by hold down ring 362 and gland 364 that is threadably coupled to pressure disk holder 358. Valving assembly 356 also includes a check valve 366. Valving assembly 356 initially prevents communication between chamber 348 and a passage 380 in a lower portion of sampling chamber 300. After actuation the pressure delivery subsystem by needle 354, check valve 366 permits fluid flow from passage 380 to chamber 348, but prevents fluid flow from chamber 348 to passage 380.

[0070] As mentioned above, one or more of the sampling chambers 300 and preferably nine of sampling chambers 300 are installed within exteriorly disposed chamber receiving slots 159 that circumscribe internal fluid passageway 112 of carrier 104. A seal bore 160 (see figure 3B) is provided in carrier 104 for receiving the upper portion of sampling chamber 300 and another seal bore 162 (see figure 3C) is provided for receiving the lower portion of sampling chamber 300. In this manner, passage 310 in the upper portion of sampling chamber 300 is placed in sealed communication with a passage 164 in carrier 104, and passage 380 in the lower portion of sampling chamber 300 is placed in sealed communication with a passage 166 in carrier 104.

[0071] As described above, once the fluid sampler is in its operable configuration and is located at the desired position within the wellbore, a fluid sample can be obtained into one or more of the sample chambers 314 by operating actuator 106. Fluid from passage 112 then enters passage 310 in the upper portion of each of the desired sampling chambers 300. For clarity, the operation of only one of the sampling chambers 300 after receipt of a fluid sample therein is described below. The fluid flows from passage 310 through check valve 316 to sample chamber 314. It is noted that check valve 316 may include a restrictor pin 368 to prevent excessive travel of ball member 370 and over compression or recoil of spiral wound compression spring 372. An initial volume of the fluid is trapped in debris chamber 326 of piston 318 as described above. Downward displacement of piston 318 is slowed by the metering fluid in chamber 320 flowing through restrictor 334. This prevents pressure in the fluid sample received in sample chamber 314 from dropping below its bubble point.

[0072] As piston 318 displaces downward, the metering fluid in chamber 320 flows through restrictor 334 into chamber 338. At this point, prong 342 maintains check valve 344 off seat. The metering fluid received in chamber 338 causes piston 346 to displace downwardly. Eventually, needle 354 pierces rupture disk 360 which actuates valving assembly 356. Actuation of valving assembly 356 permits pressure from pressure source 108 to be applied

to chamber 348. Specifically, once rupture disk 360 is pierced, the pressure from pressure source 108 passes through valving assembly 356 including moving check valve 366 off seat. In the illustrated embodiment, a restrictor pin 374 prevents excessive travel of check valve 366 and over compression or recoil of spiral wound compression spring 376. Pressurization of chamber 348 also results in pressure being applied to chambers 338, 320 and thus to sample chamber 314.

[0073] When the pressure from pressure source 108 is applied to chamber 338, pins 378 are sheared allowing piston assembly 340 to collapse such that prong 342 no longer maintains check valve 344 off seat. Check valve 344 then prevents pressure from escaping from chamber 320 and sample chamber 314. Check valve 316 also prevents escape of pressure from sample chamber 314. In this manner, the fluid sample received in sample chamber 314 is pressurized.

[0074] While this invention has been described with a reference to illustrative embodiments, this description is not intended to be construed in a limiting sense. Various modifications and combinations of the illustrative embodiments as well as other embodiments of the invention, will be apparent to persons skilled in the art upon reference to the description.

Statements -

[0075]

1. Apparatus for obtaining a fluid sample in a subterranean well, the apparatus comprising:

a housing having a sample chamber defined therein, the sample chamber selectively in fluid communication with the exterior of the housing and operable to receive the fluid sample therefrom; and

a debris trap piston slidably disposed within the housing, the debris trap piston including a debris chamber, responsive to the fluid sample entering the sample chamber, the debris trap piston receiving a first portion of the fluid sample in the debris chamber then displacing relative to the housing to expand the sample chamber.

2. Apparatus according to statement 1, wherein the debris trap piston includes a passageway having a cross sectional area that is smaller than the cross sectional area of the debris chamber, wherein the first portion of the fluid sample passes from the sample chamber through the passageway to enter the debris chamber.

3. Apparatus according to statement 2, wherein the first portion of the fluid sample is retained in the debris chamber due to pressure from the sample chamber applied to the debris chamber through the pas-

sageway.

4. Apparatus according to any preceding statement, further comprising a magnetic locator operably associated with the debris trap piston, the magnetic locator providing a reference to determine the level of displacement of the debris trap piston.

5. A method for obtaining a fluid sample in a subterranean well, the method comprising:

disposing a sampling chamber within the subterranean well;

actuating the sampling chamber such that a sample chamber within the sampling chamber is in fluid communication with the exterior of the sampling chamber;

receiving a first portion of the fluid sample in a debris chamber of a debris trap piston slidably disposed within the sampling chamber;

displacing the debris trap piston within the sampling chamber to expand the sample chamber; and

receiving the remainder of the fluid sample in the sample chamber.

6. A method according to statement 5, wherein the step of receiving a first portion of the fluid sample in a debris chamber further comprises passing the first portion of the fluid sample through the sample chamber and through a passageway of the debris trap piston before entering the debris chamber, wherein the passageway has a cross sectional area that is smaller than the cross sectional area of the debris chamber.

7. A method according to statement 6, further comprising the step of retaining the first portion of the fluid sample in the debris chamber by applying pressure from the sample chamber to the debris chamber through the passageway.

8. A downhole tool comprising:

a housing having a longitudinal passageway; a piston disposed within the longitudinal passageway, the piston including a piercing assembly; and

a valving assembly disposed within the longitudinal passageway, the valving assembly including a pressure disk that is initially operable to maintain a differential pressure thereacross, wherein the valving assembly is actuated by longitudinally displacing the piston relative to the valving assembly such that at least a portion of the piercing assembly travels through the pressure disk, thereby allowing fluid flow there-through.

9. A downhole tool according to statement 8, wherein the piercing assembly further comprises a piercing assembly body and a needle and wherein the needle is held within the piercing assembly body by one of compression, friction, threading and welding.

10. A downhole tool according to statement 9, wherein the needle has a sharp point that travels through the pressure disk.

7. A downhole tool according to claim 1, wherein the downhole tool is an apparatus for obtaining a fluid sample in a subterranean well.

5 8. A downhole tool according to claim 1, wherein the pressure disk further comprises a rupture disk.

10

Claims

1. A downhole tool comprising:

15

a housing having a longitudinal passageway;
a piston disposed within the longitudinal passageway, the piston including a piercing assembly;

a valving assembly disposed within the longitudinal passageway, the valving assembly including a pressure disk that is initially operable to maintain a differential pressure thereacross, wherein the valving assembly is actuated by longitudinally displacing the piston relative to the valving assembly such that at least a portion of the piercing assembly travels through the pressure disk, thereby allowing the pressure to equalize thereacross; and

20

25

a magnetic locator operably associated with the piston, the level of displacement of the piston determinable based upon the location of the magnetic locator.

30

2. A downhole tool according to claim 1, wherein the piercing assembly further comprises a piercing assembly body and a needle and wherein the needle is held within the piercing assembly body by one of compression, friction, threading and welding.

35

40

3. A downhole tool according to claim 2, wherein the needle has a sharp point that travels through the pressure disk.

4. A downhole tool according to claim 2, wherein the needle has an outer surface selected from one of a smooth outer surface, a fluted outer surface, a channeled outer surface and a knurled outer surface.

45

5. A downhole tool according to claim 1, wherein the piston is displaced relative to the valving assembly and the housing.

50

6. A downhole tool according to claim 1, wherein the valving assembly further comprises a check valve that allows fluid flow in a first direction and prevents fluid flow in a second direction through the valving assembly once the valving assembly is actuated.

55

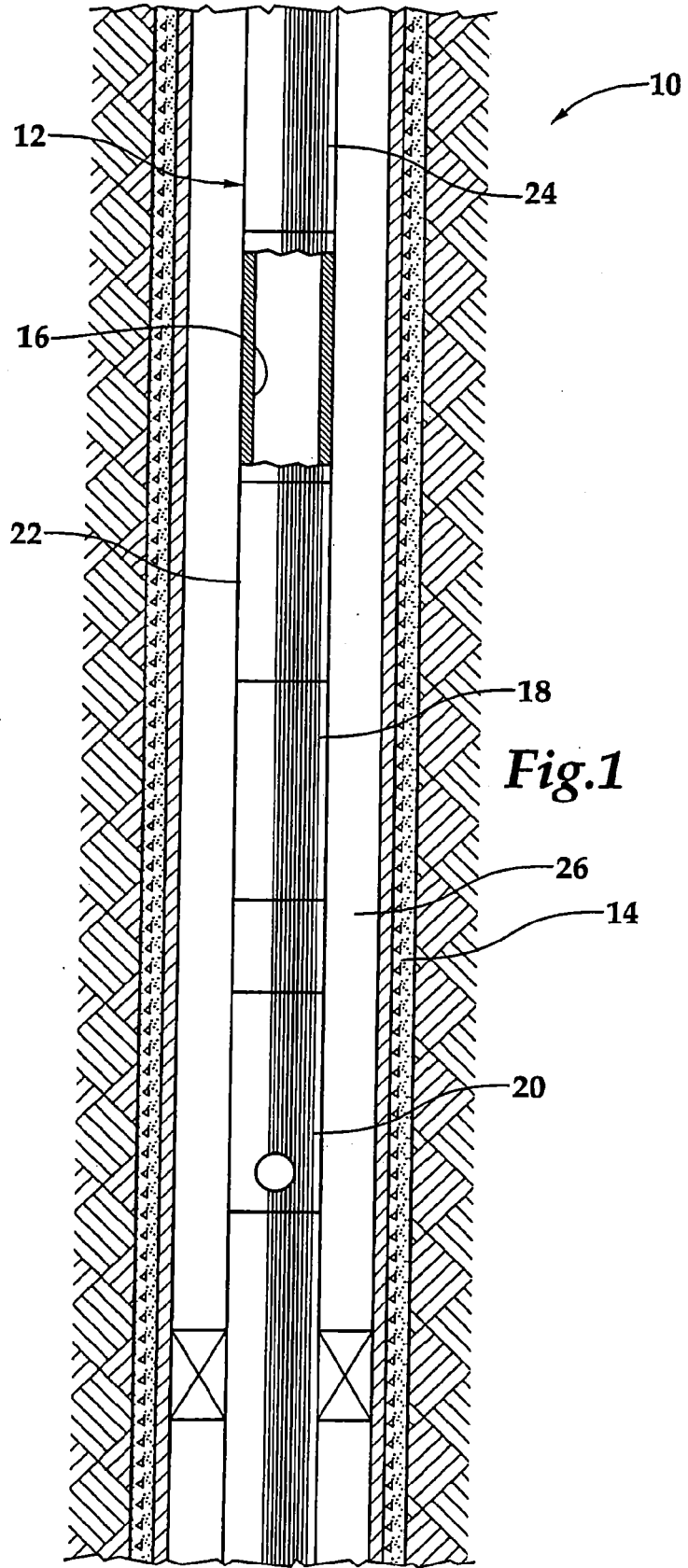

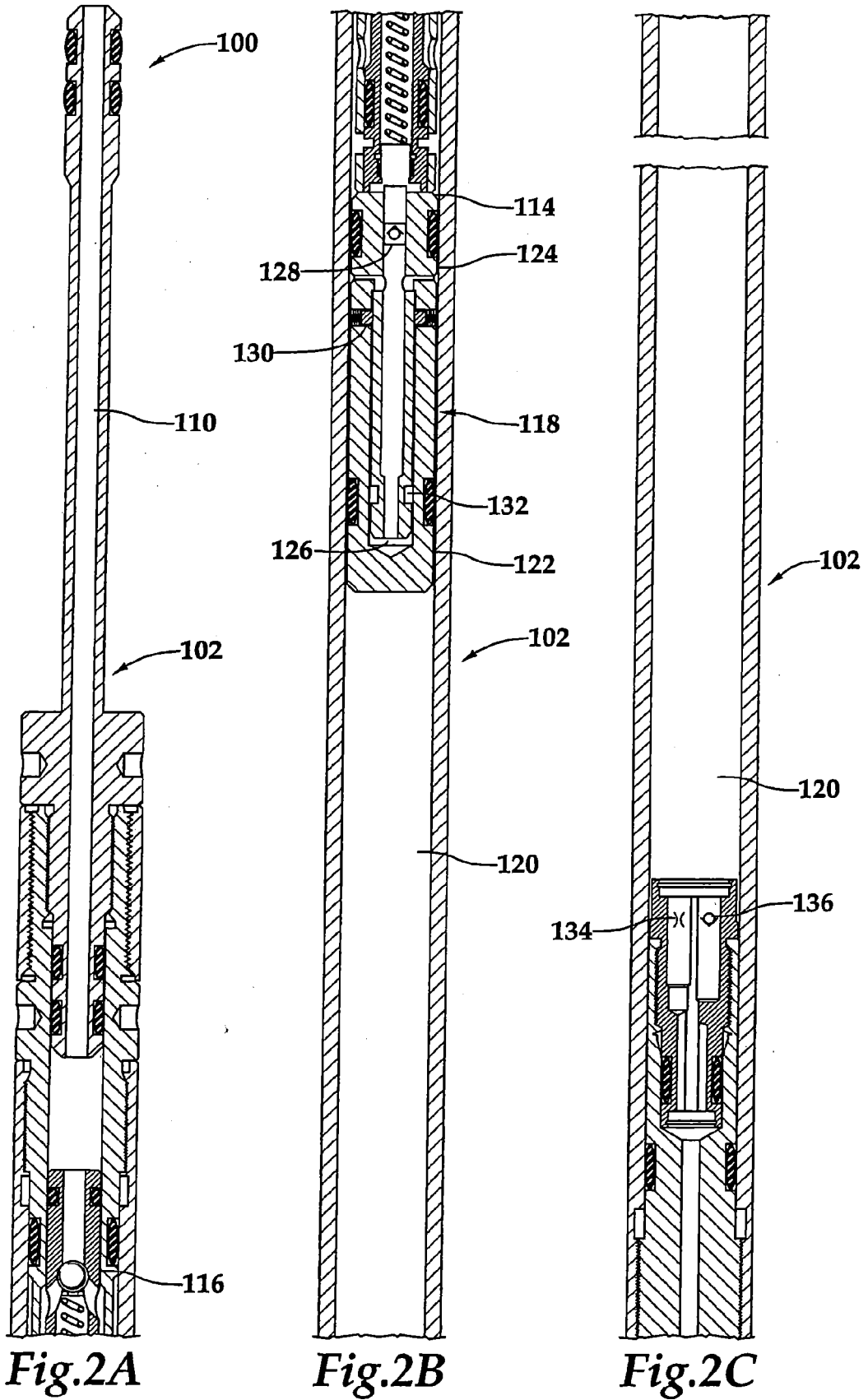

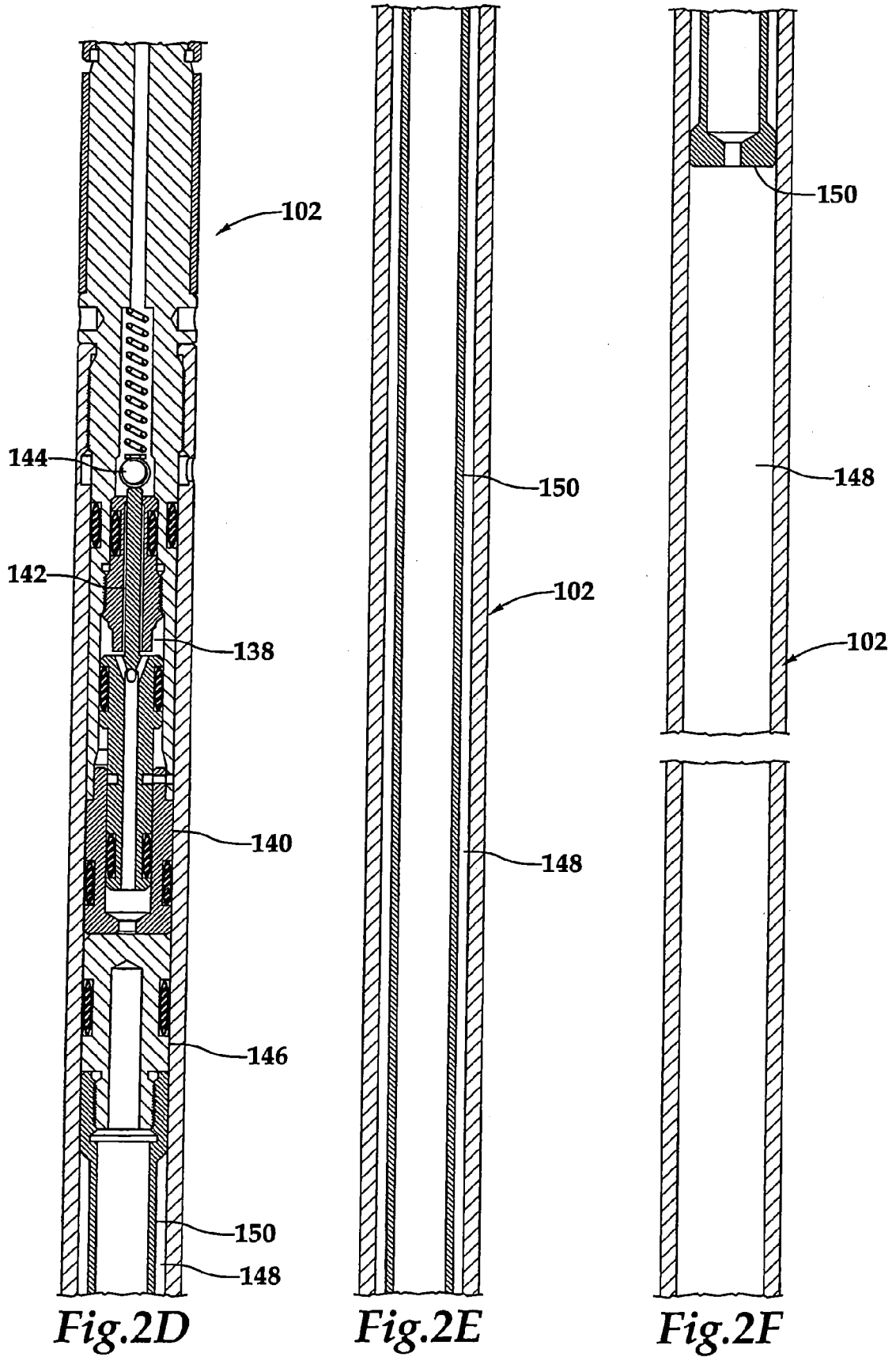

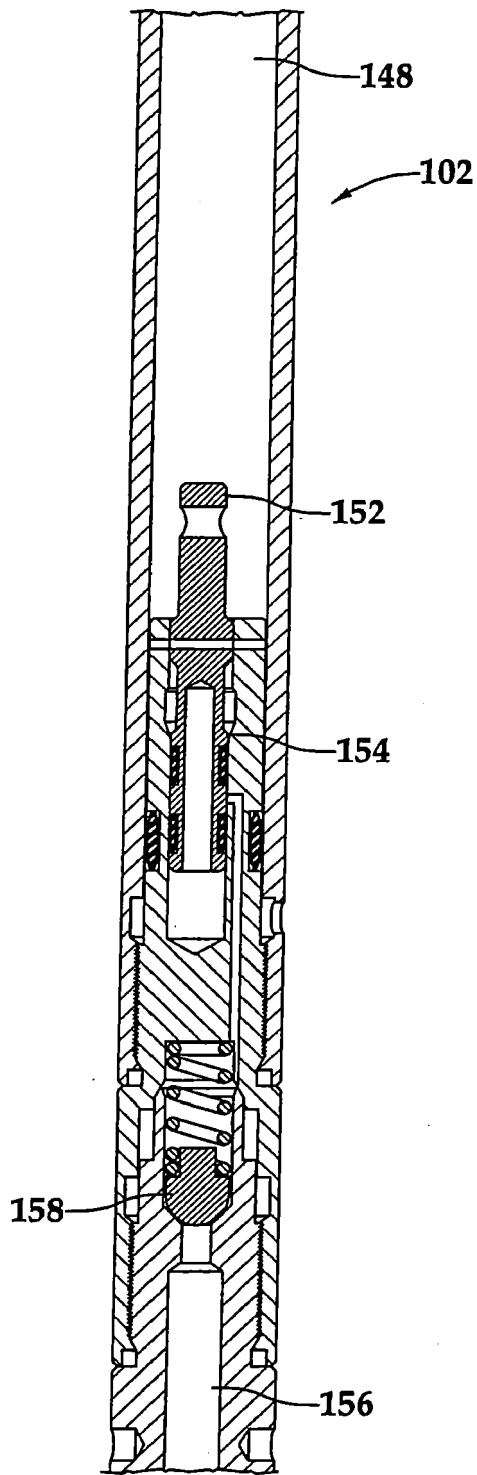

Fig. 2G

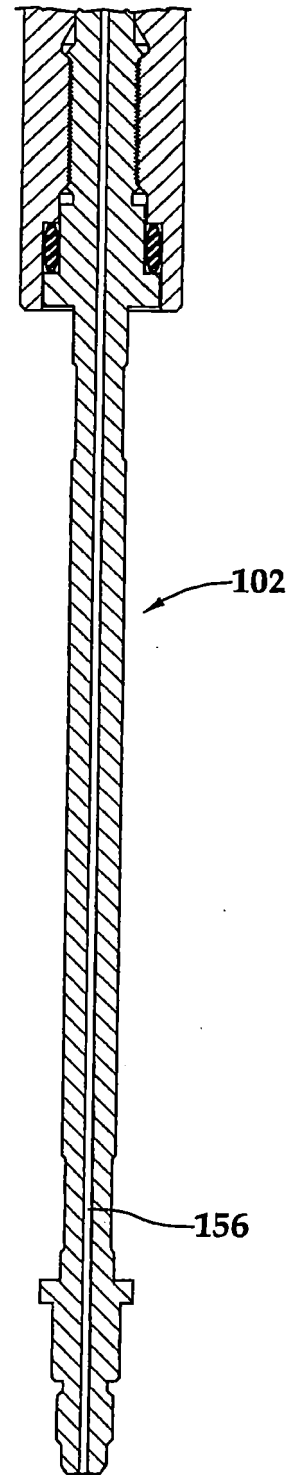

Fig. 2H

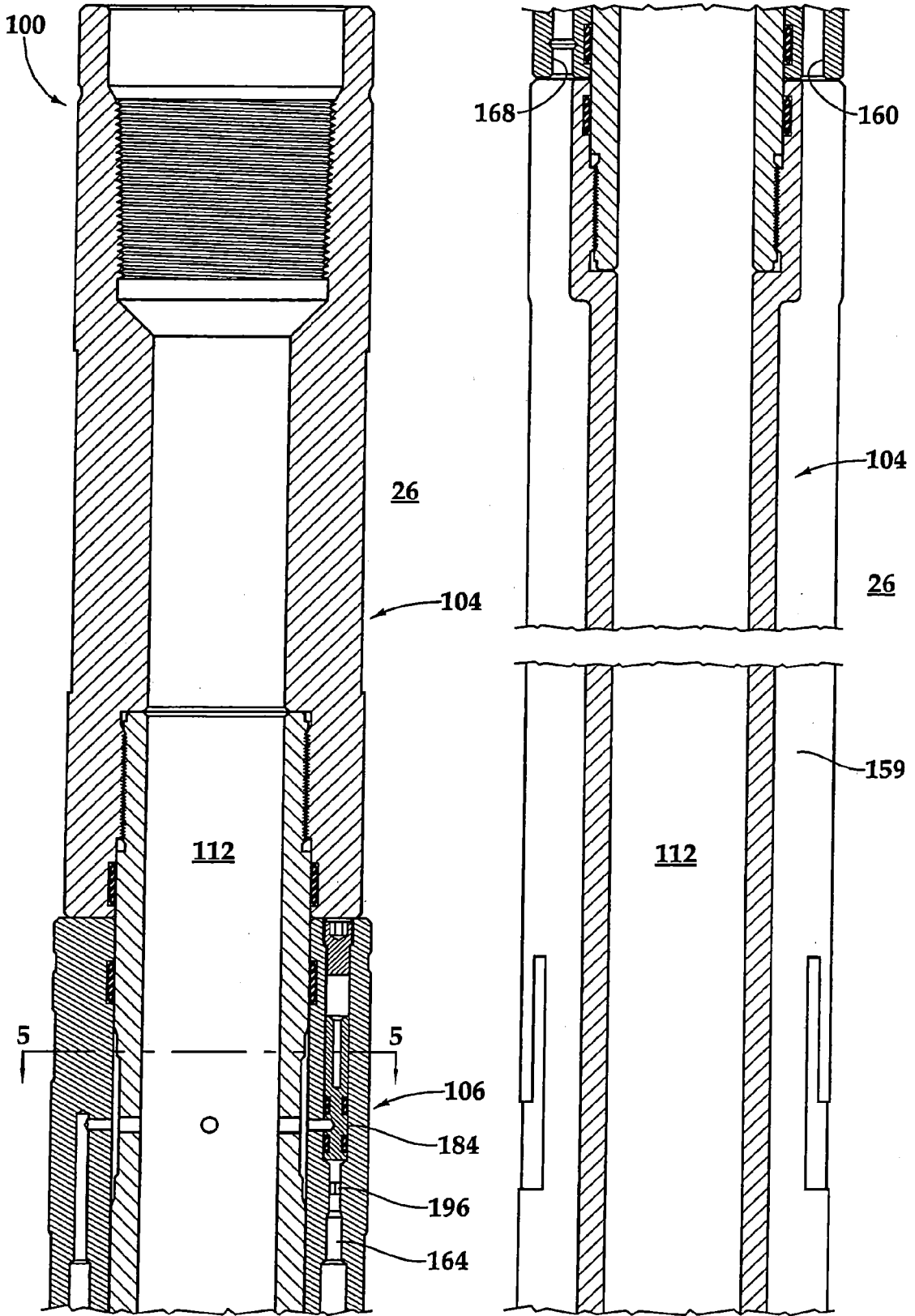

Fig.3A

Fig.3B

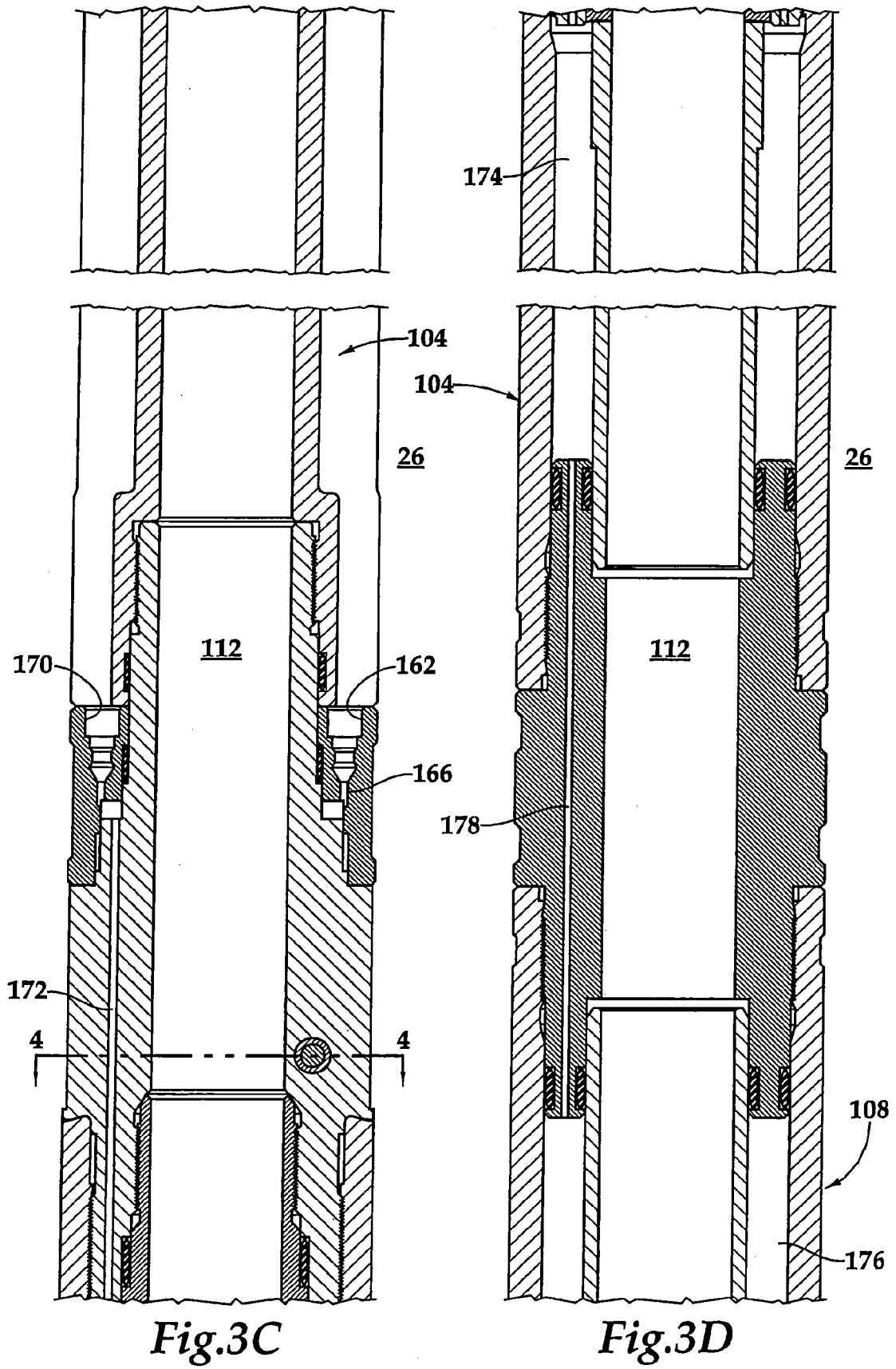

Fig.3C

Fig.3D

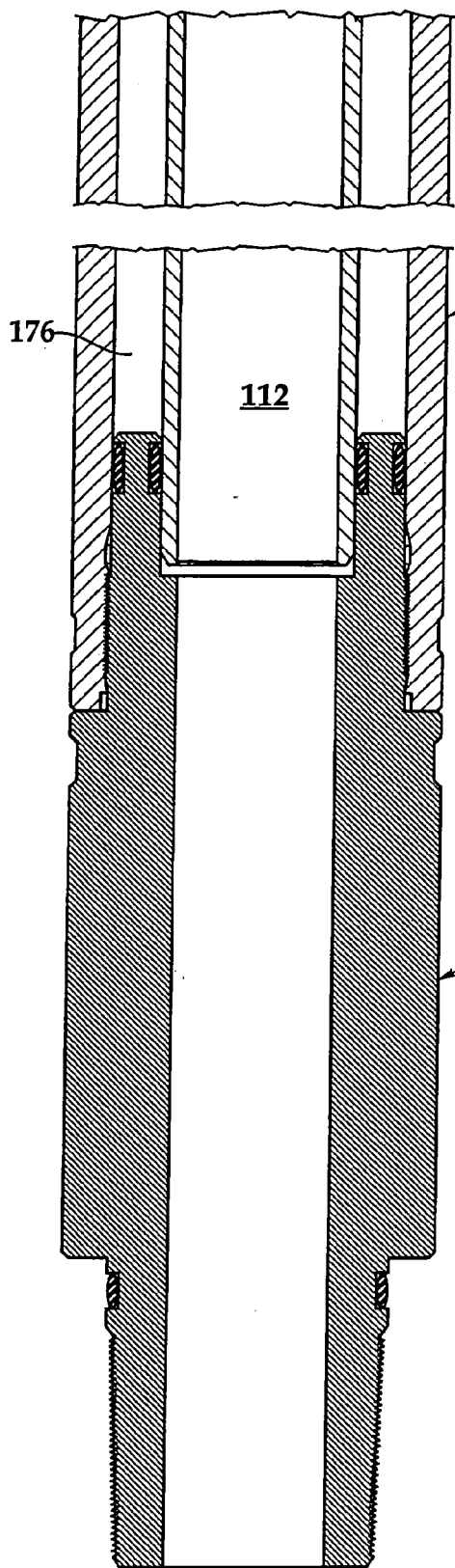

Fig.3E

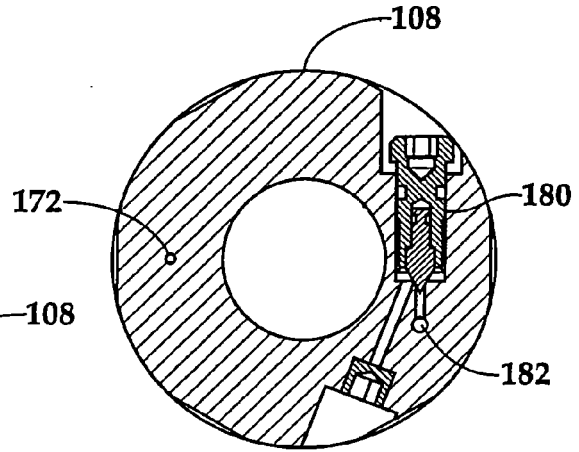

Fig.4

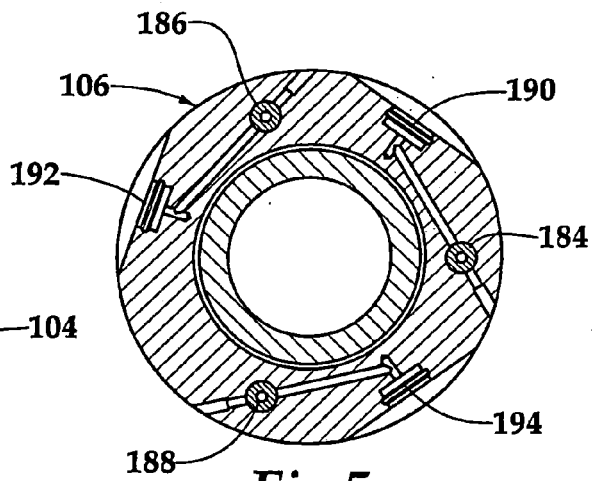

Fig.5

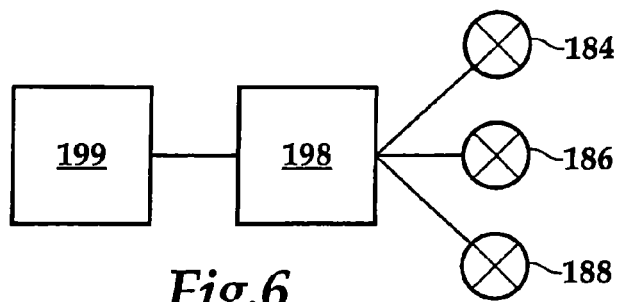

Fig.6

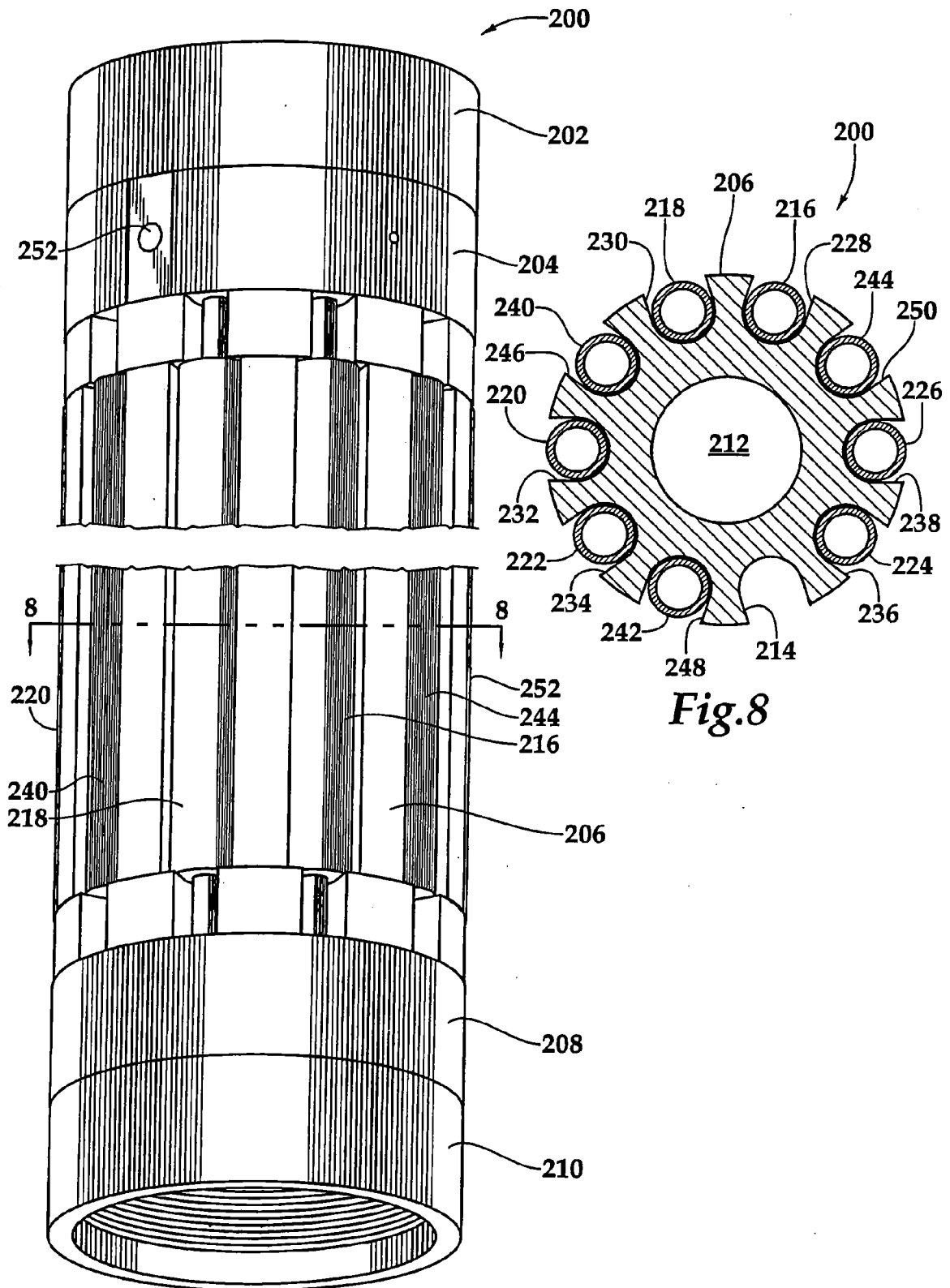

Fig.7

Fig.8

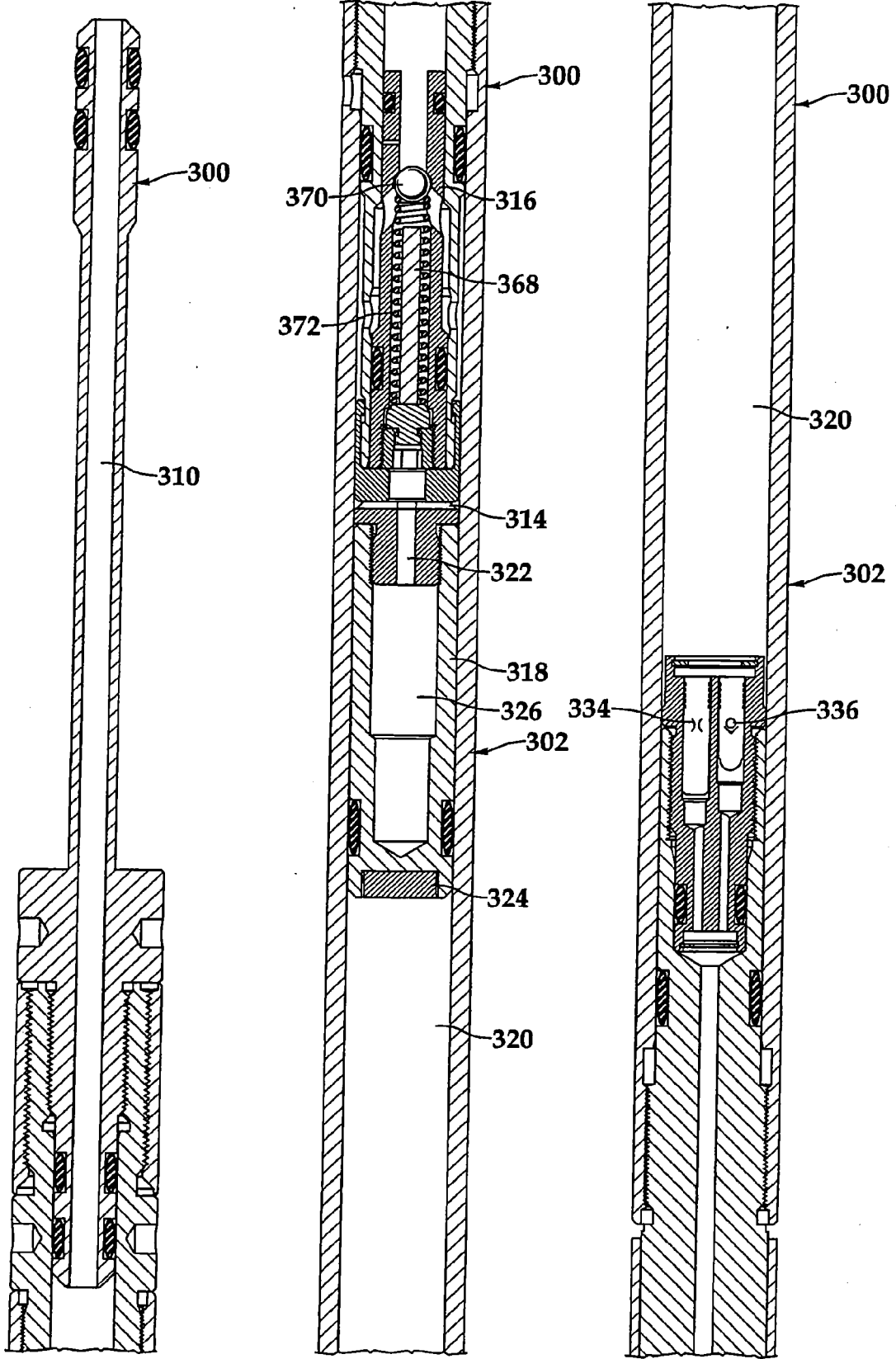

Fig.9A

Fig.9B

Fig.9C

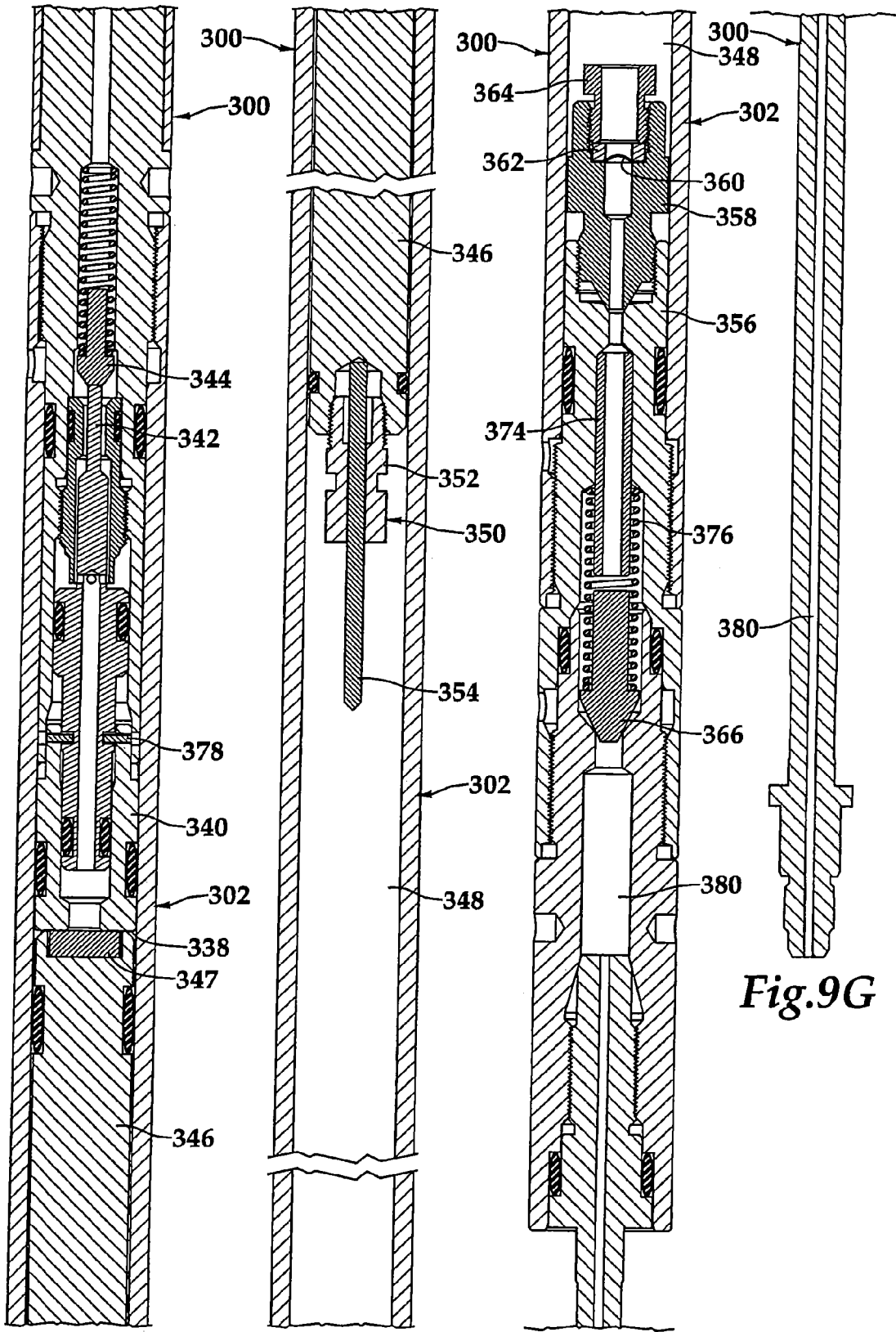

Fig. 9D

Fig. 9E

Fig. 9F

Fig. 9G



EUROPEAN SEARCH REPORT

Application Number
EP 14 20 0641

5

10

15

20

25

30

35

40

45

50

55

DOCUMENTS CONSIDERED TO BE RELEVANT			
Category	Citation of document with indication, where appropriate, of relevant passages	Relevant to claim	CLASSIFICATION OF THE APPLICATION (IPC)
Y	US 6 340 062 B1 (SKINNER NEAL G [US]) 22 January 2002 (2002-01-22) * figures 1,2C-20 * * column 1, lines 4-9 * * column 2, lines 21-55 * * column 3, lines 1-58 * * column 4, lines 21-62 * * column 5, line 60 - column 6, line 17 * * column 7, line 53 - column 8, line 5 *	1-5,7,8	INV. E21B49/08
Y	US 2006/137479 A1 (GILBERT GREGORY N [US]) 29 June 2006 (2006-06-29) * figures 1 2, 5 * * abstract * * paragraphs [0001], [0029], [0036] - [0037] *	1-5,7,8	
A	AU 769 002 B2 (WESTERN WELL TOOL INC) 15 January 2004 (2004-01-15) * figures 1, 4A-D, 50 * * page 1a, lines 5-8 * * page 57, line 28 - page 58, line 2 * * page 65, line 30 - page 66, line 8 *	1	TECHNICAL FIELDS SEARCHED (IPC) E21B
A	GB 2 388 854 A (SCHLUMBERGER HOLDINGS [VG]) 26 November 2003 (2003-11-26) * figures 1, 7, 9 * * page 4, lines 2-11 * * page 14, lines 10-24 *	1	
A	WO 01/77480 A2 (WEATHERFORD LAMB [US]; HARDING RICHARD PATRICK [GB]; BRUNNERT DAVID J) 18 October 2001 (2001-10-18) * figures 1, 3A-B * * page 9, lines 22-31 *	1	
The present search report has been drawn up for all claims			
Place of search The Hague		Date of completion of the search 23 April 2015	Examiner Brassart, P
CATEGORY OF CITED DOCUMENTS X : particularly relevant if taken alone Y : particularly relevant if combined with another document of the same category A : technological background O : non-written disclosure P : intermediate document		T : theory or principle underlying the invention E : earlier patent document, but published on, or after the filing date D : document cited in the application L : document cited for other reasons & : member of the same patent family, corresponding document	

EPO FORM 1503 03.82 (P04C01)

ANNEX TO THE EUROPEAN SEARCH REPORT
ON EUROPEAN PATENT APPLICATION NO.

EP 14 20 0641

5

This annex lists the patent family members relating to the patent documents cited in the above-mentioned European search report.
The members are as contained in the European Patent Office EDP file on
The European Patent Office is in no way liable for these particulars which are merely given for the purpose of information.

23-04-2015

10

15

20

25

30

35

40

45

50

55

Patent document cited in search report	Publication date	Patent family member(s)	Publication date	
US 6340062	B1	22-01-2002	US 6340062 B1	22-01-2002
			US 2002023780 A1	28-02-2002
			US 2002027006 A1	07-03-2002

US 2006137479	A1	29-06-2006	NONE	

AU 769002	B2	15-01-2004	NONE	

GB 2388854	A	26-11-2003	GB 2388854 A	26-11-2003
			GB 2406123 A	23-03-2005
			GB 2406124 A	23-03-2005
			NO 20031761 A	17-10-2003
			US 2004026086 A1	12-02-2004

WO 0177480	A2	18-10-2001	AU 4440901 A	23-10-2001
			CA 2403293 A1	18-10-2001
			EP 1272727 A2	08-01-2003
			NO 20024411 A	20-11-2002
			US 6364037 B1	02-04-2002
			US 2002060096 A1	23-05-2002
			WO 0177480 A2	18-10-2001

EPO FORM P0459

For more details about this annex : see Official Journal of the European Patent Office, No. 12/82