



US 20170047987A1

(19) **United States**

(12) **Patent Application Publication**
Pellegrino et al.

(10) **Pub. No.: US 2017/0047987 A1**

(43) **Pub. Date: Feb. 16, 2017**

(54) **SYSTEMS AND METHODS FOR PERFORMING SHAPE ESTIMATION USING SUN SENSORS IN LARGE-SCALE SPACE-BASED SOLAR POWER STATIONS**

provisional application No. 62/340,644, filed on May 24, 2016, provisional application No. 62/352,392, filed on Jun. 20, 2016, provisional application No. 62/366,720, filed on Jul. 26, 2016.

(71) Applicant: **California Institute of Technology**, Pasadena, CA (US)
(72) Inventors: **Sergio Pellegrino**, Pasadena, CA (US); **Seyed All Hajimiri**, La Canada, CA (US); **Harry A. Atwater**, South Pasadena, CA (US); **Thibaud Talon**, Pasadena, CA (US)
(73) Assignee: **California Institute of Technology**, Pasadena, CA (US)

Publication Classification

(51) **Int. Cl.**
H04B 7/185 (2006.01)
H04B 7/06 (2006.01)
H04L 27/152 (2006.01)
H04L 27/26 (2006.01)
H04L 25/08 (2006.01)
(52) **U.S. Cl.**
CPC **H04B 7/18513** (2013.01); **H04L 27/261** (2013.01); **H04L 25/085** (2013.01); **H04L 27/152** (2013.01); **H04B 7/0617** (2013.01)

(21) Appl. No.: **15/233,776**

(57) **ABSTRACT**

(22) Filed: **Aug. 10, 2016**

A space-based solar power station, a power generating satellite module and/or a method for collecting solar radiation and transmitting power generated using electrical current produced therefrom is provided. Power transmitters can be coordinated as a phased array and the power generated by the phased array is transmitted to one or more power receivers to achieve remote wireless power generation and delivery. In many embodiments, a reference signal is distributed within the space-based solar power station to coordinate the phased array. In several embodiments, determinations of the relative locations of the antennas in the array are generated by an array of sun sensors that estimate the shape of the module to evaluate the phase shift and/or amplitude modulation to apply to the reference signal at each power transmitter.

Related U.S. Application Data

(60) Provisional application No. 62/203,159, filed on Aug. 10, 2015, provisional application No. 62/220,017, filed on Sep. 17, 2015, provisional application No. 62/239,706, filed on Oct. 9, 2015, provisional application No. 62/264,500, filed on Dec. 8, 2015, provisional application No. 62/268,632, filed on Dec. 17, 2015, provisional application No. 62/270,425, filed on Dec. 21, 2015, provisional application No. 62/295,947, filed on Feb. 16, 2016, provisional application No. 62/320,819, filed on Apr. 11, 2016, provisional application No. 62/330,341, filed on May 2, 2016,

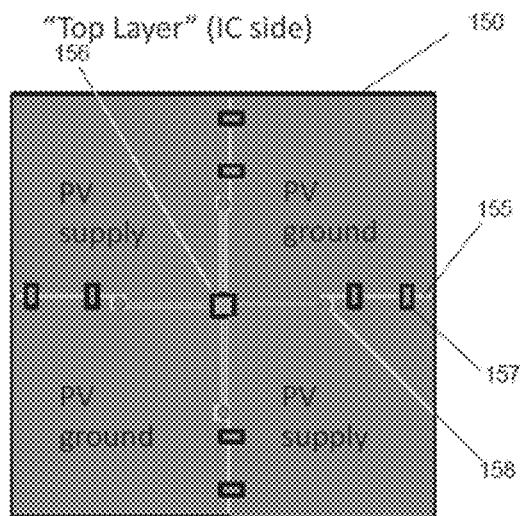

Location of IC Possible bypass caps
 Connection to Patch antenna RF connection to patch antenna

FIG. 1

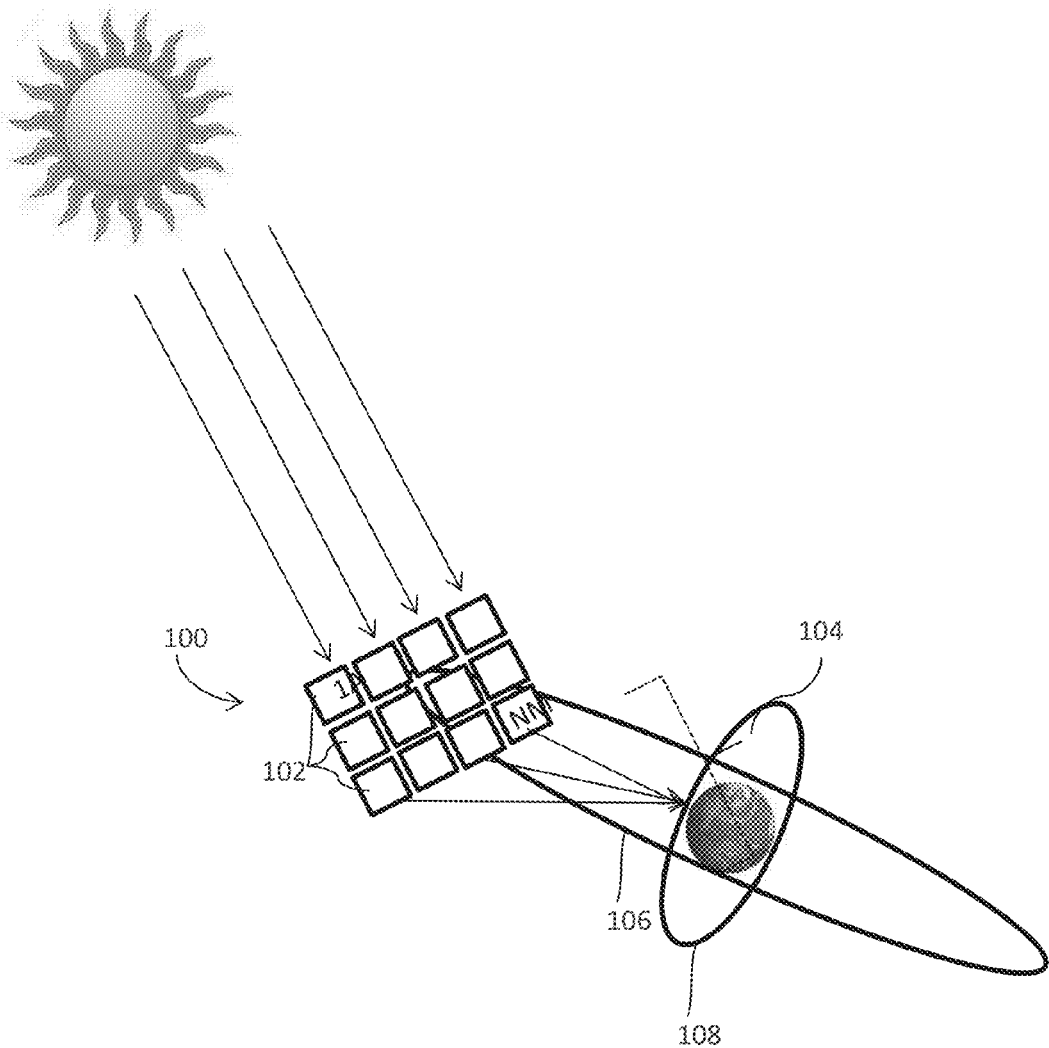

FIG. 2

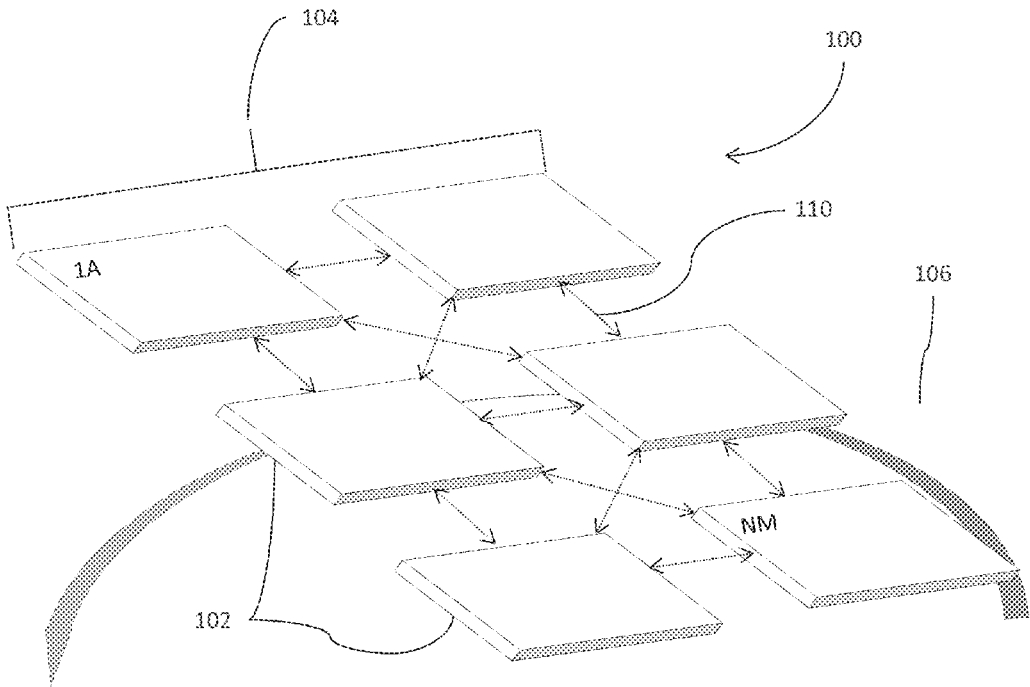

FIG. 3

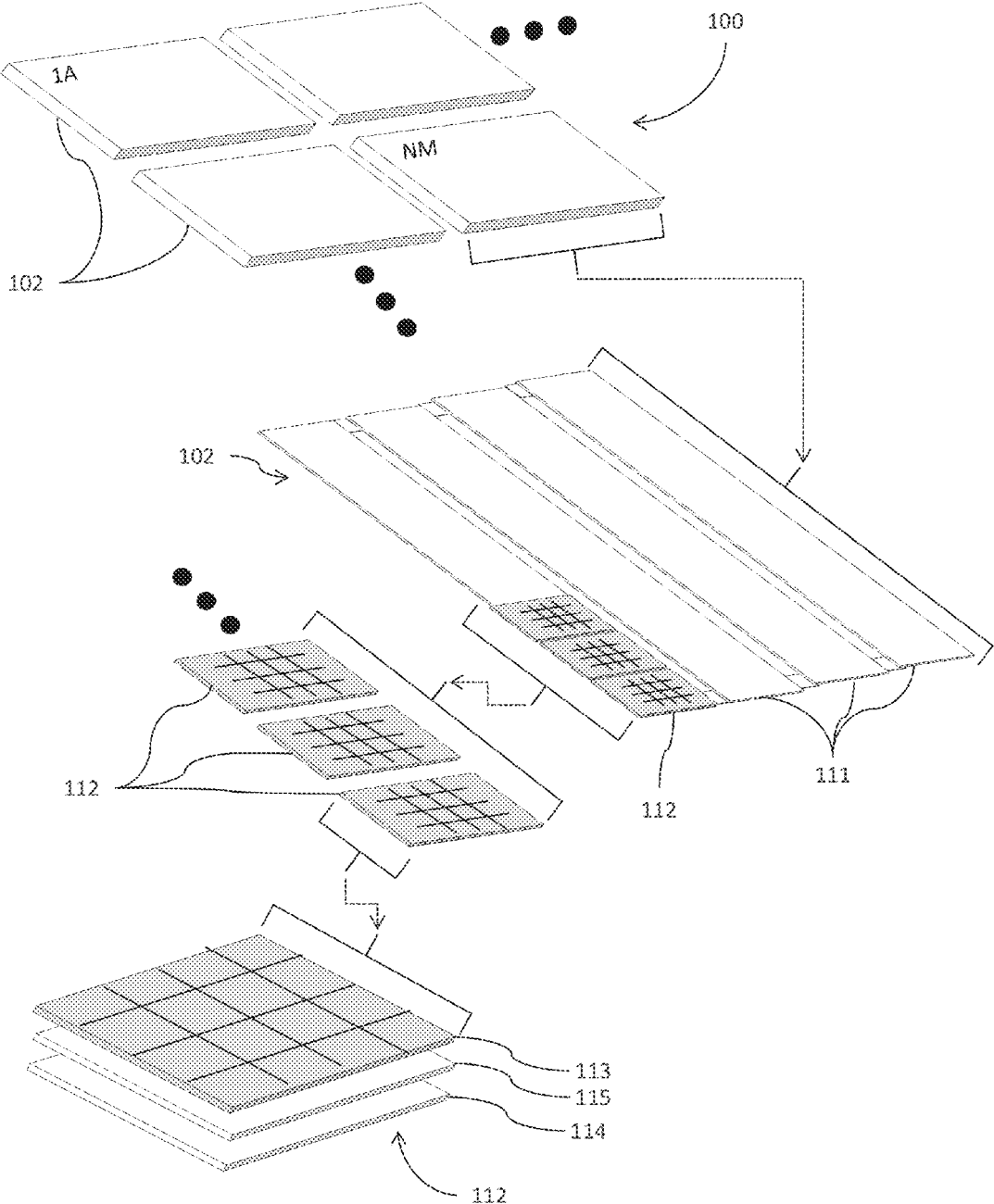

FIG. 4a

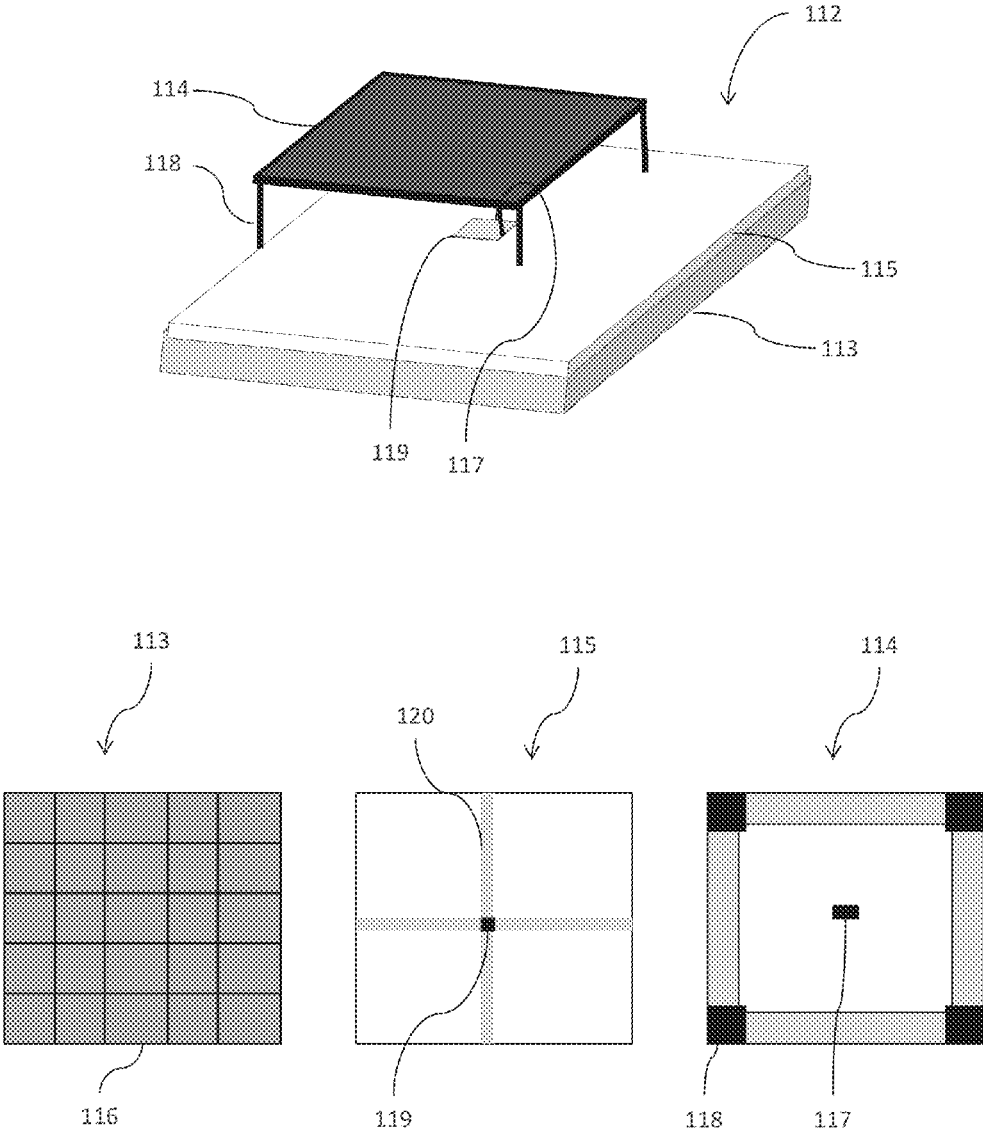
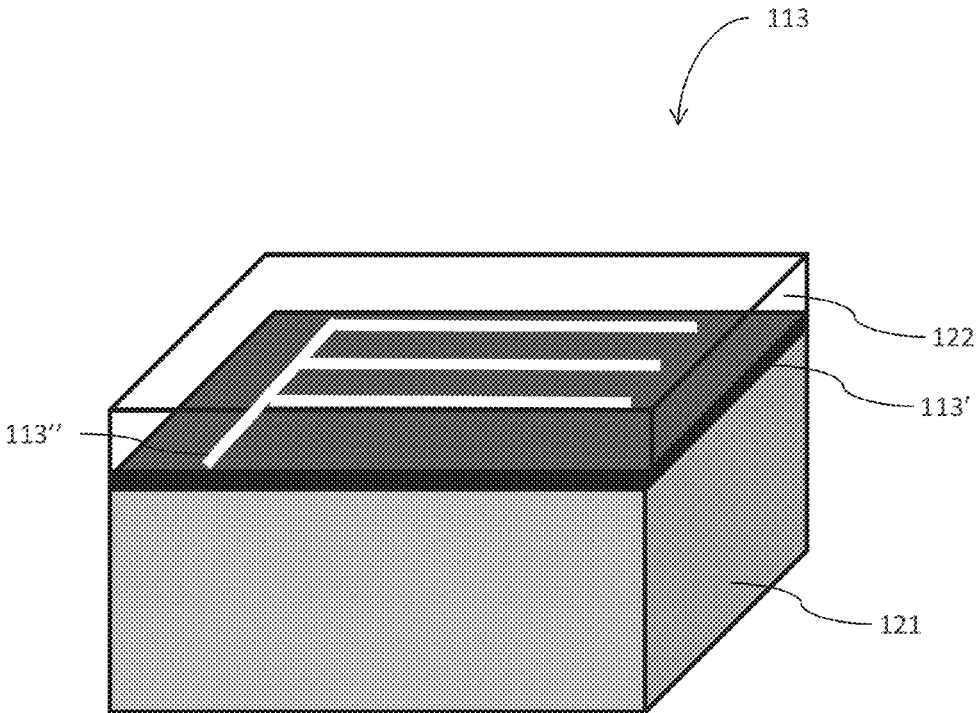

FIG. 4b



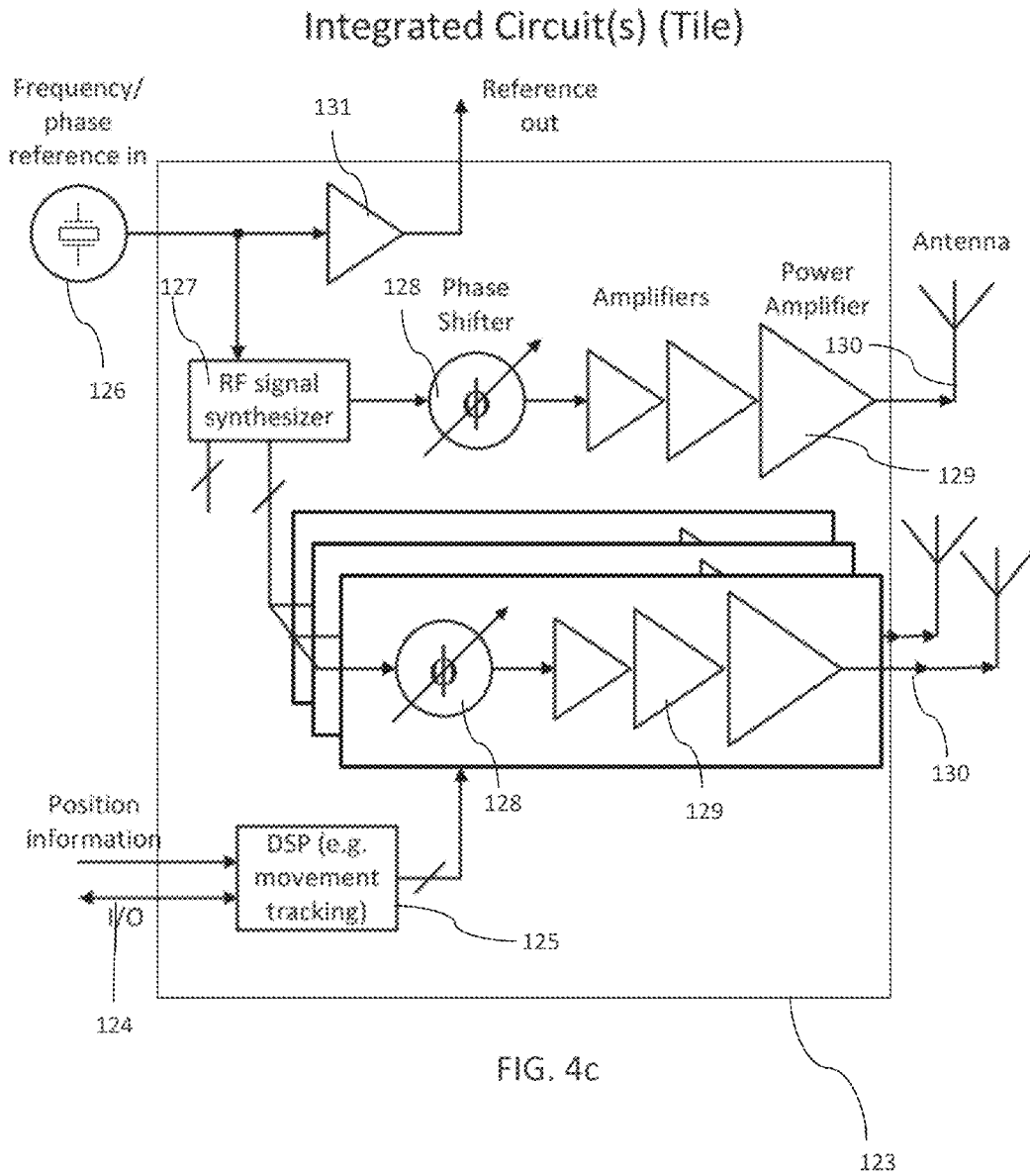

FIG. 4c

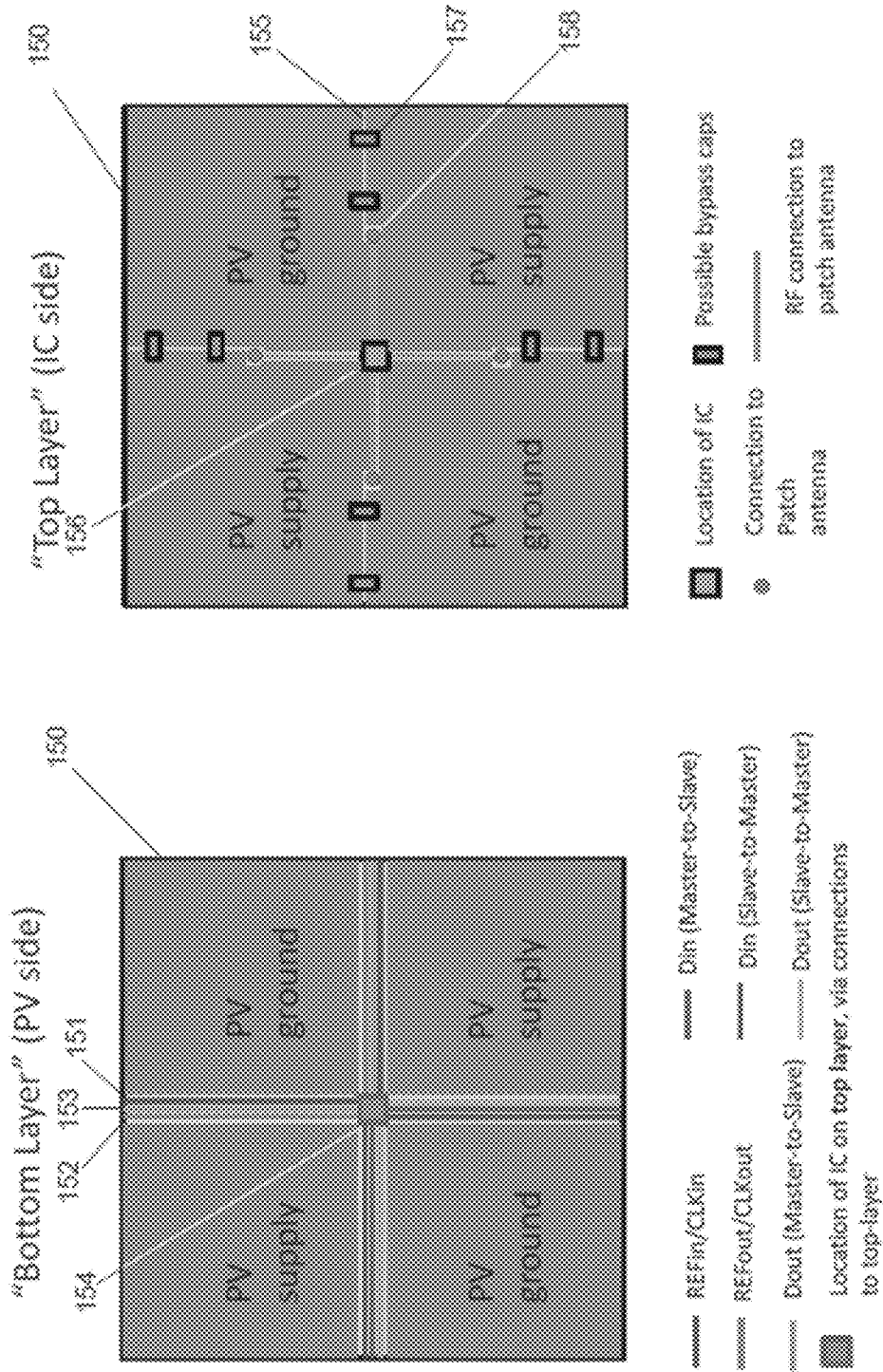

Fig. 4e

Fig. 4d

102 →

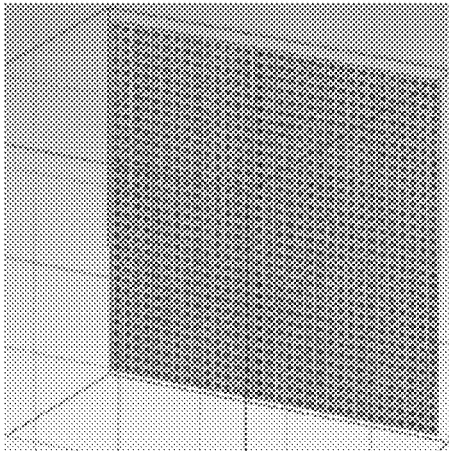

FIG. 5a

162

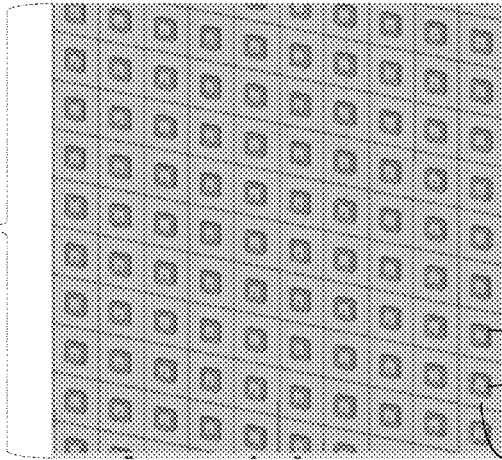

FIG. 5b

112

160

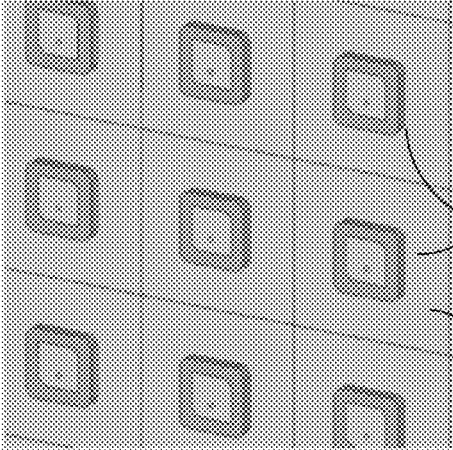
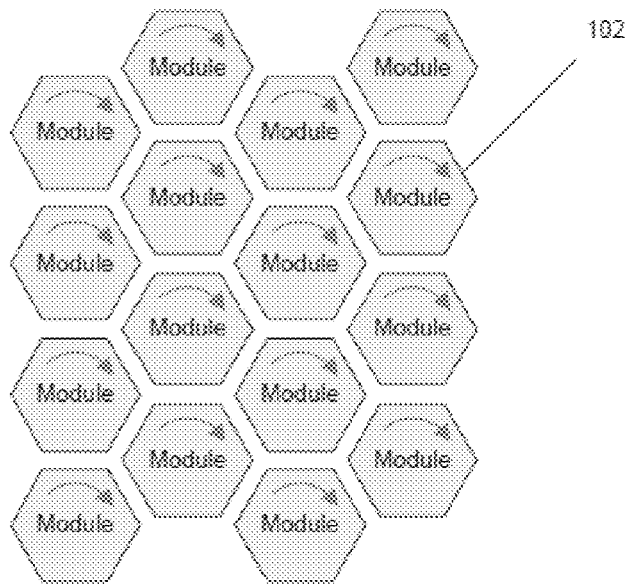
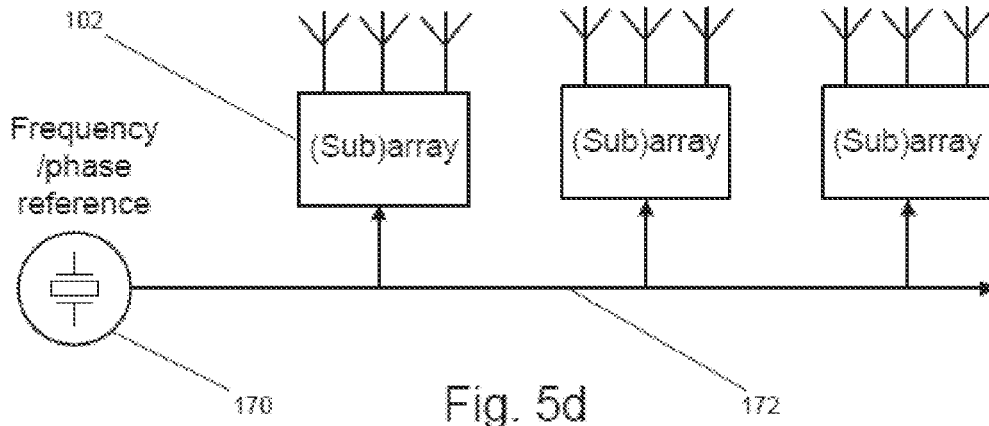

FIG. 5c

160

112



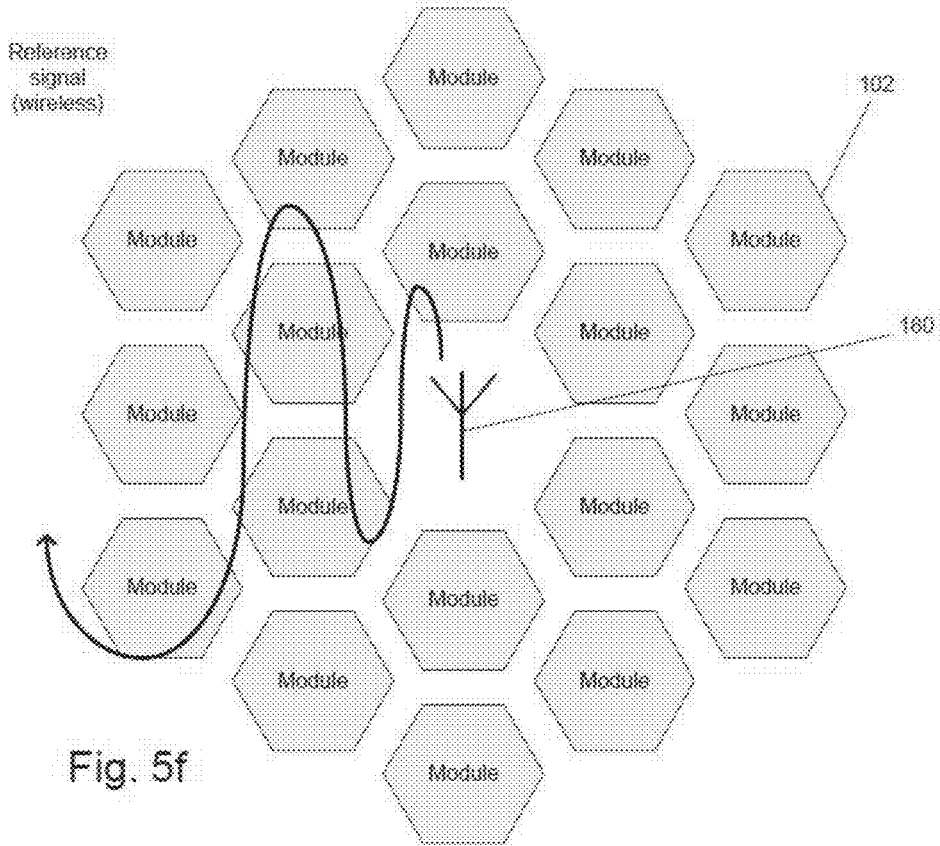

Fig. 5f

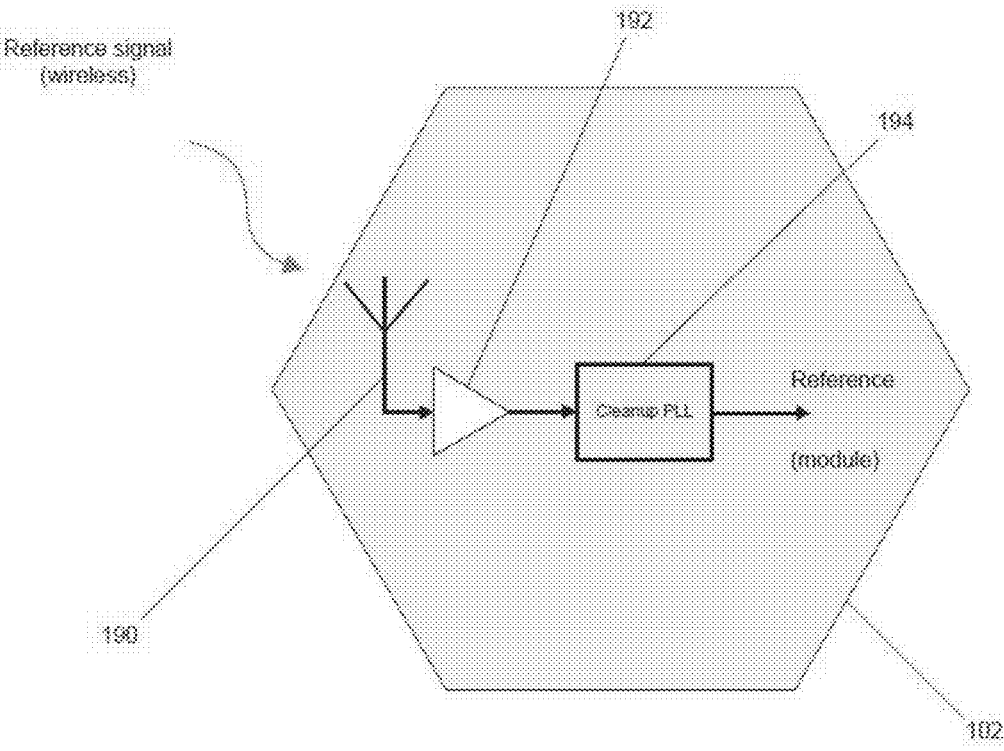

Fig. 5g

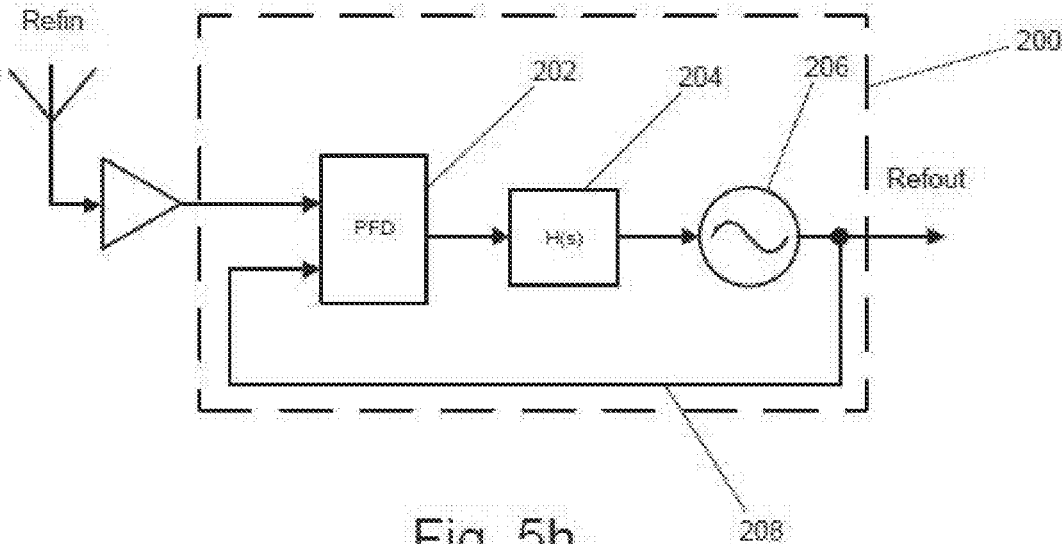

Fig. 5h

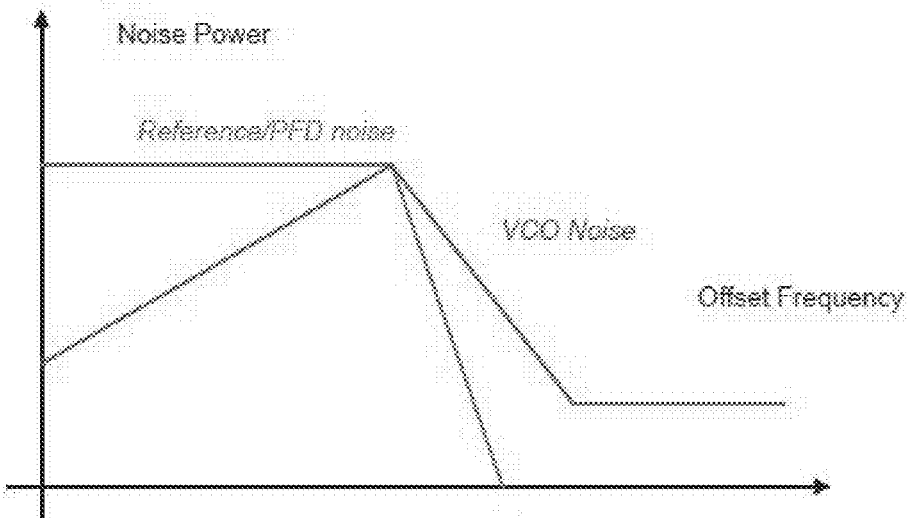

Fig. 5i

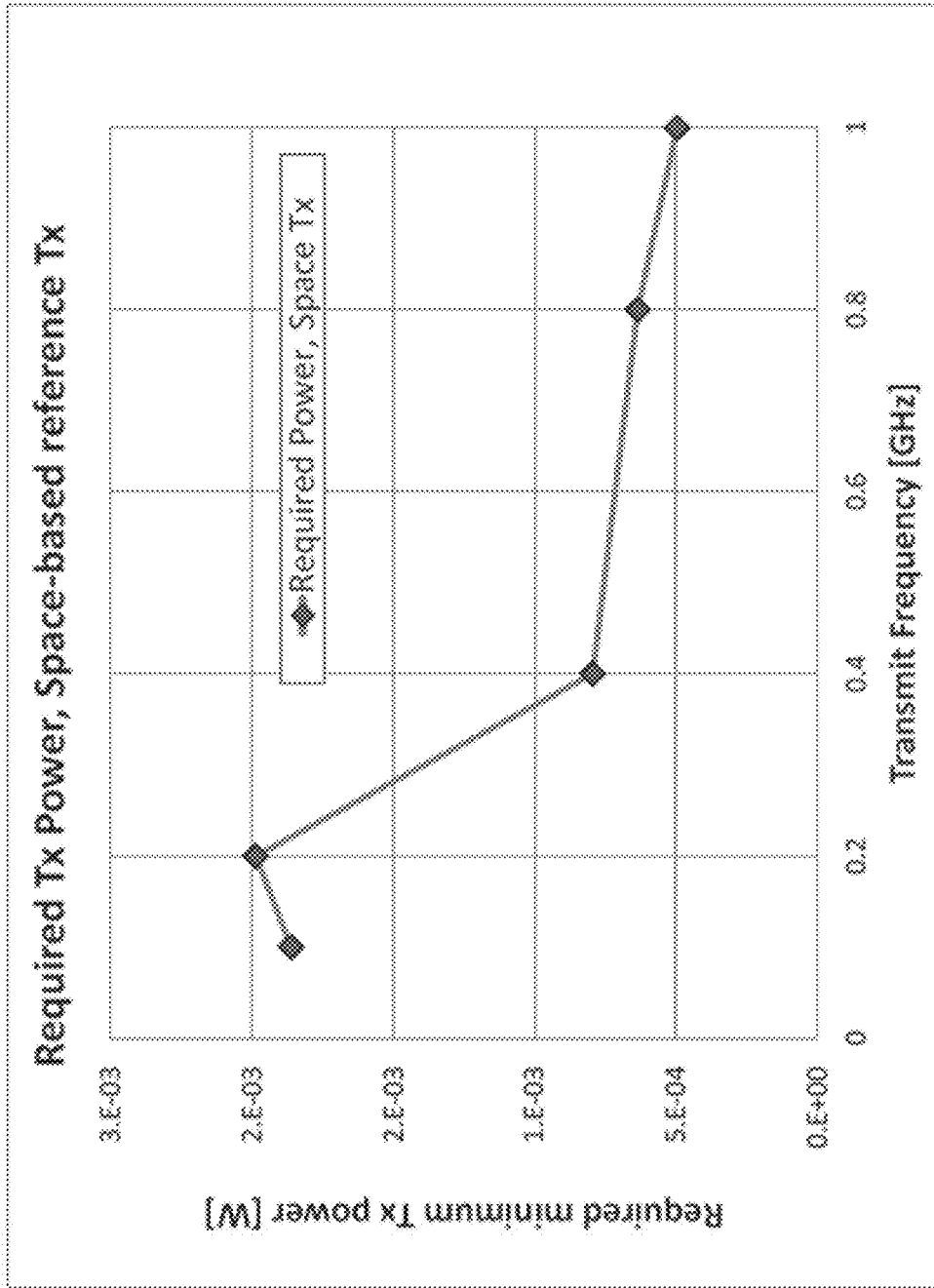

Fig. 5j

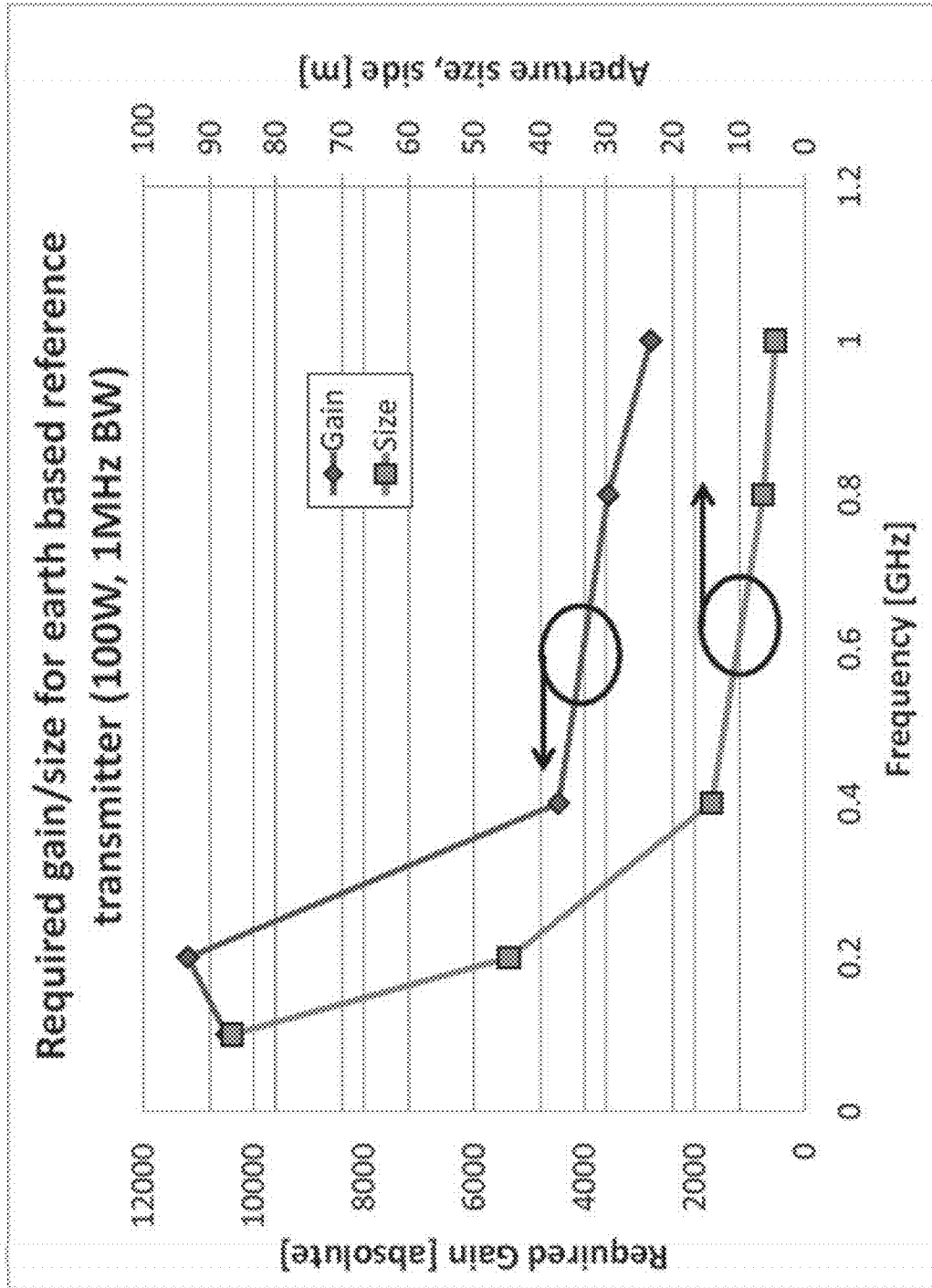

Fig. 5k

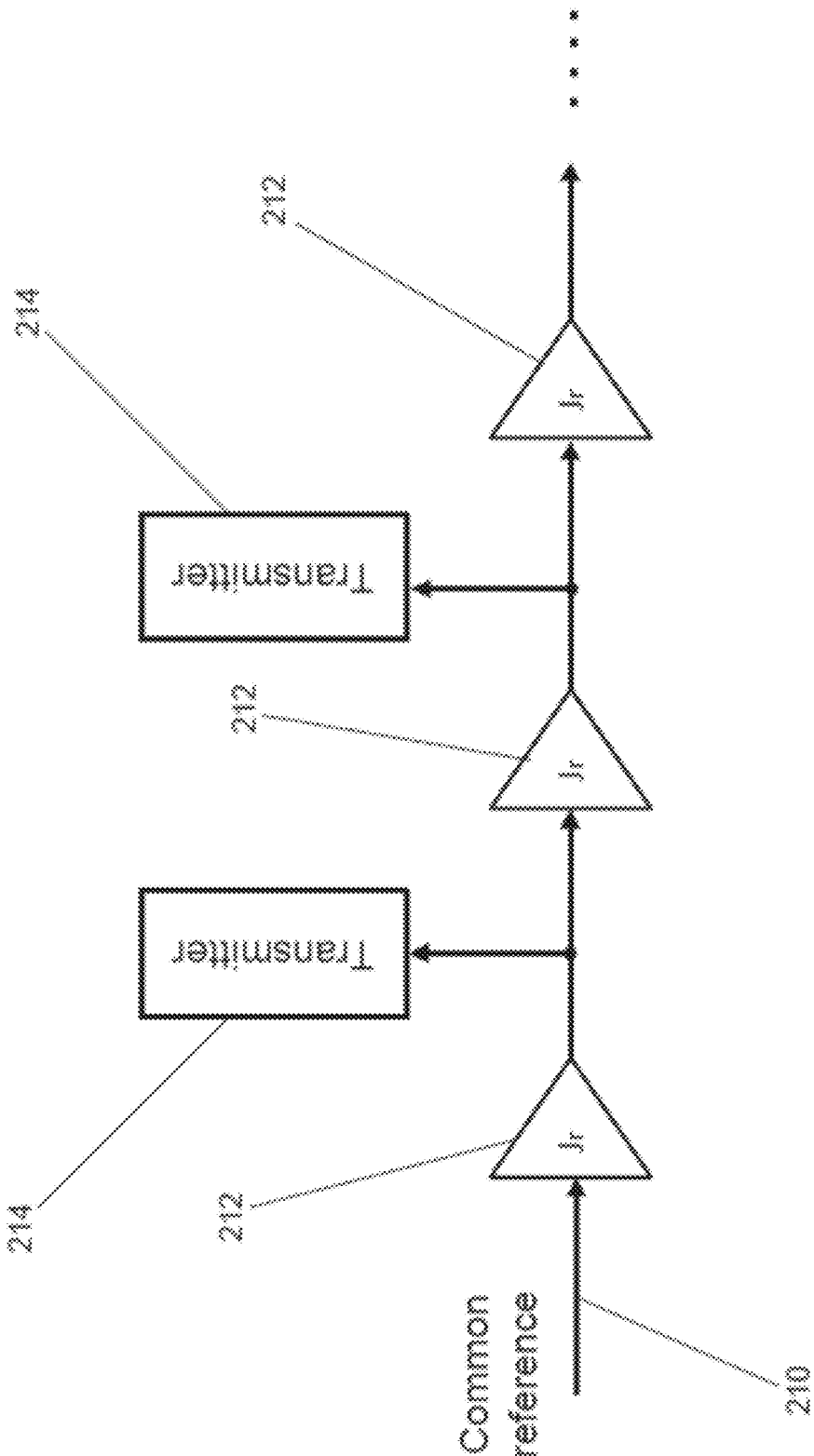

Fig. 51

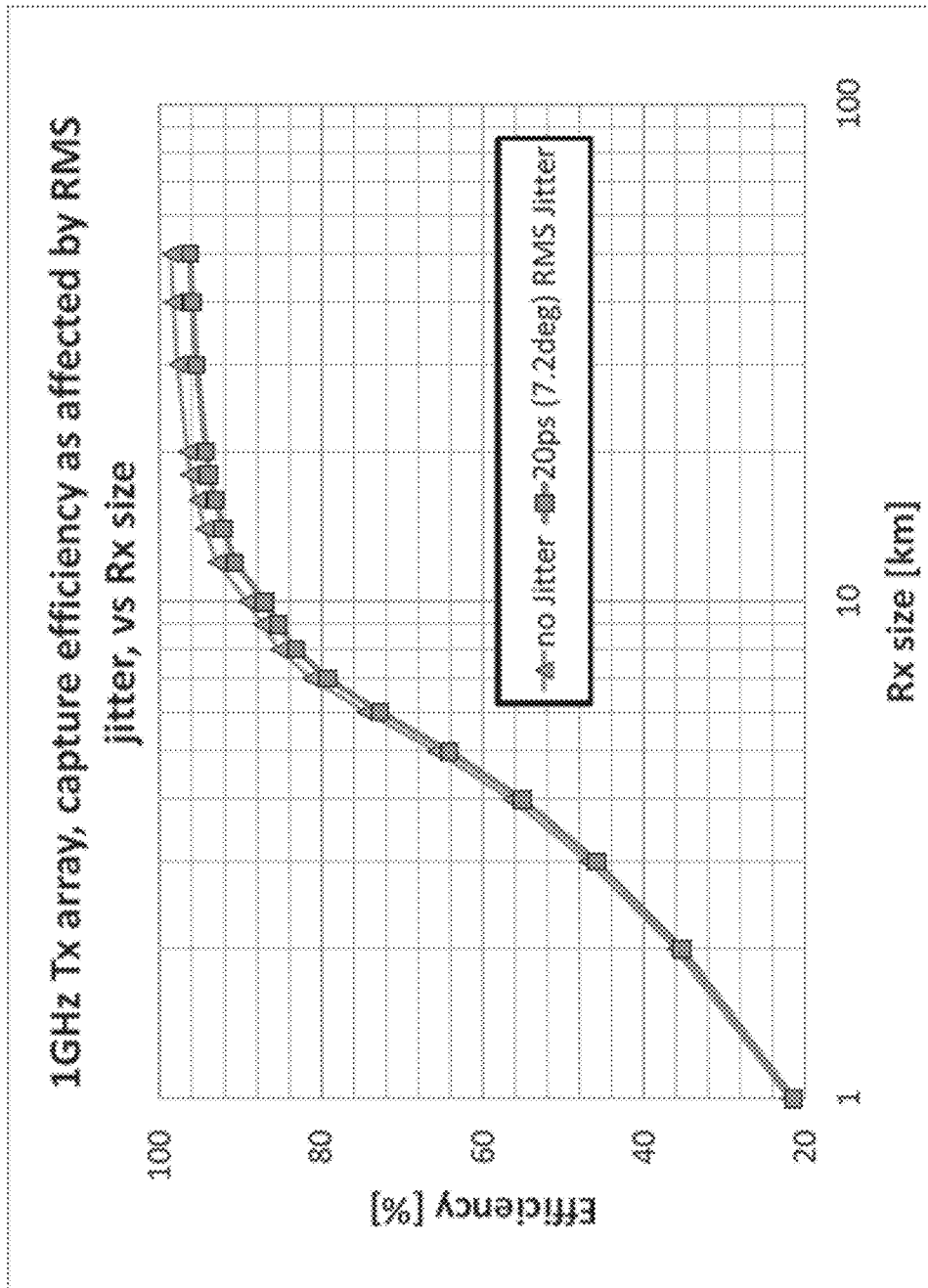

Fig. 5m

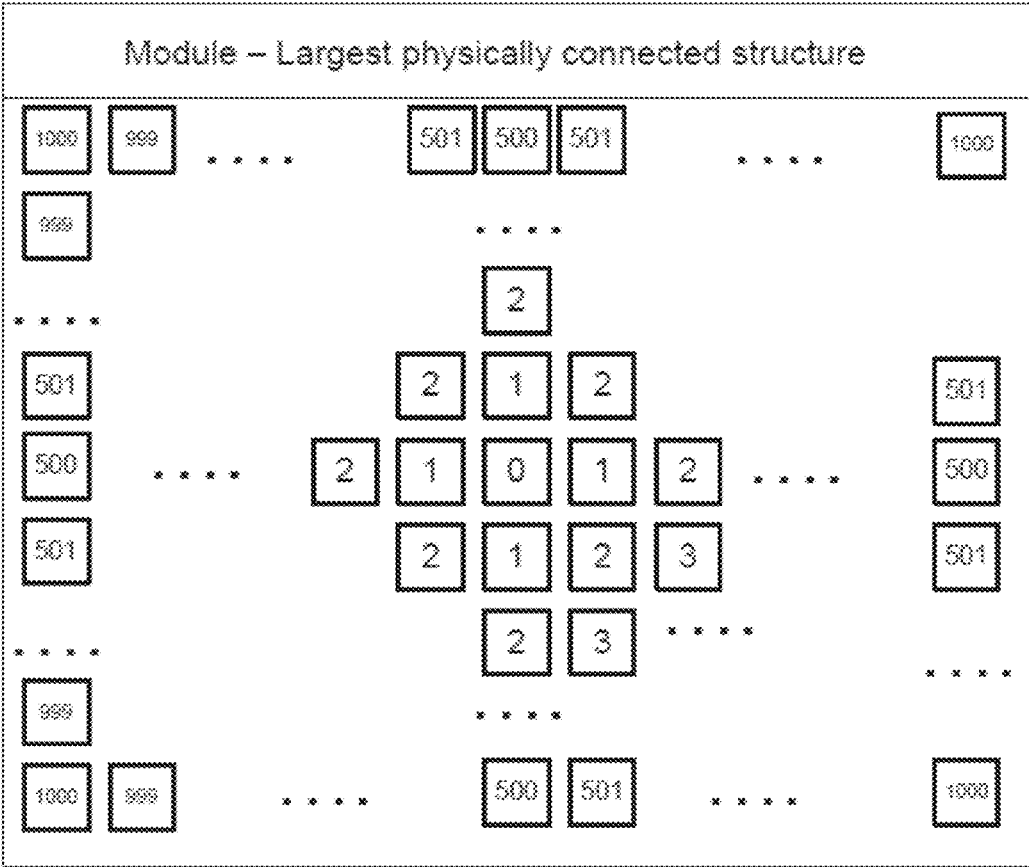

Fig. 5n

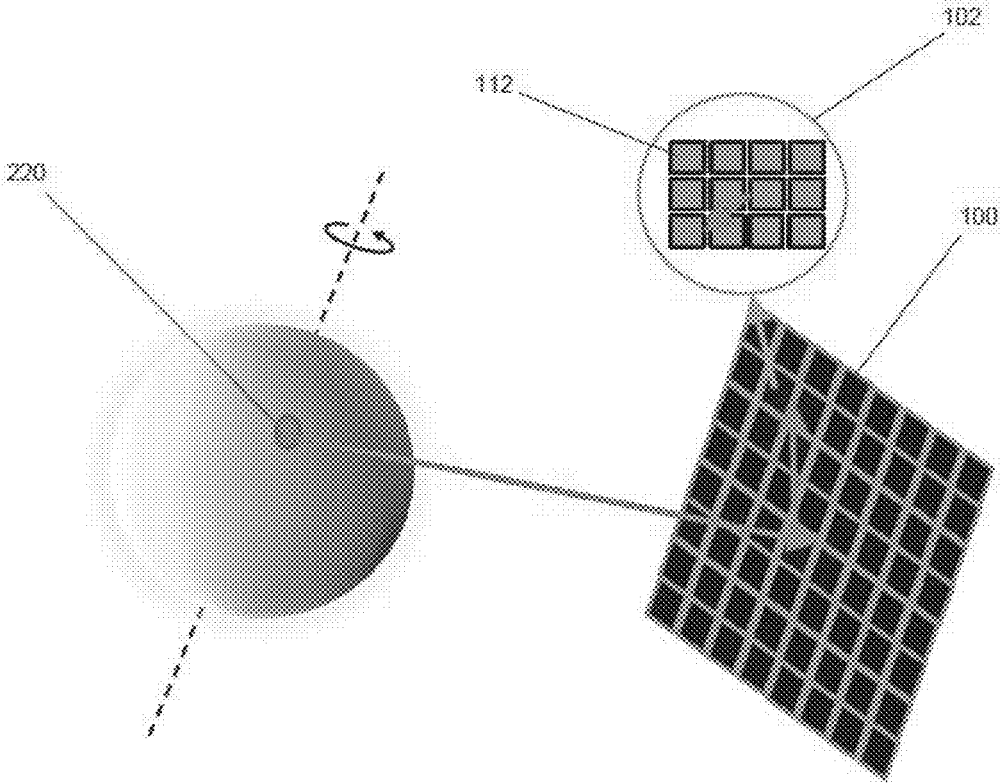

Fig. 5o

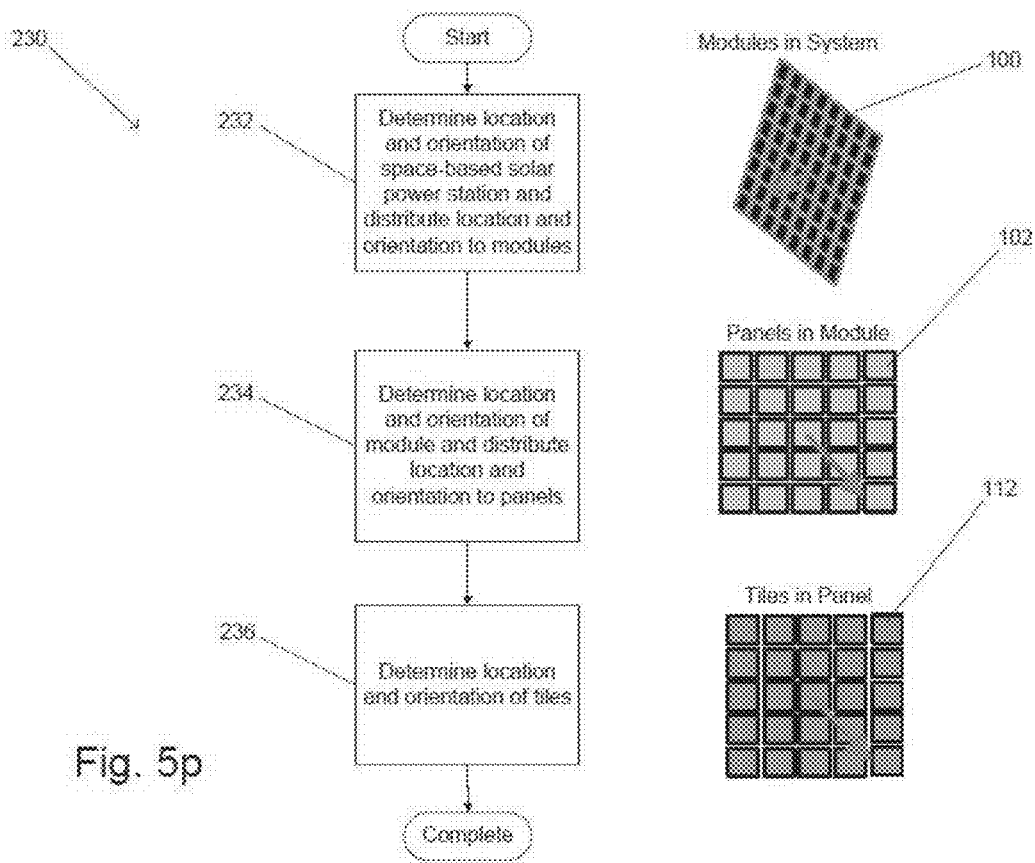

Fig. 5p

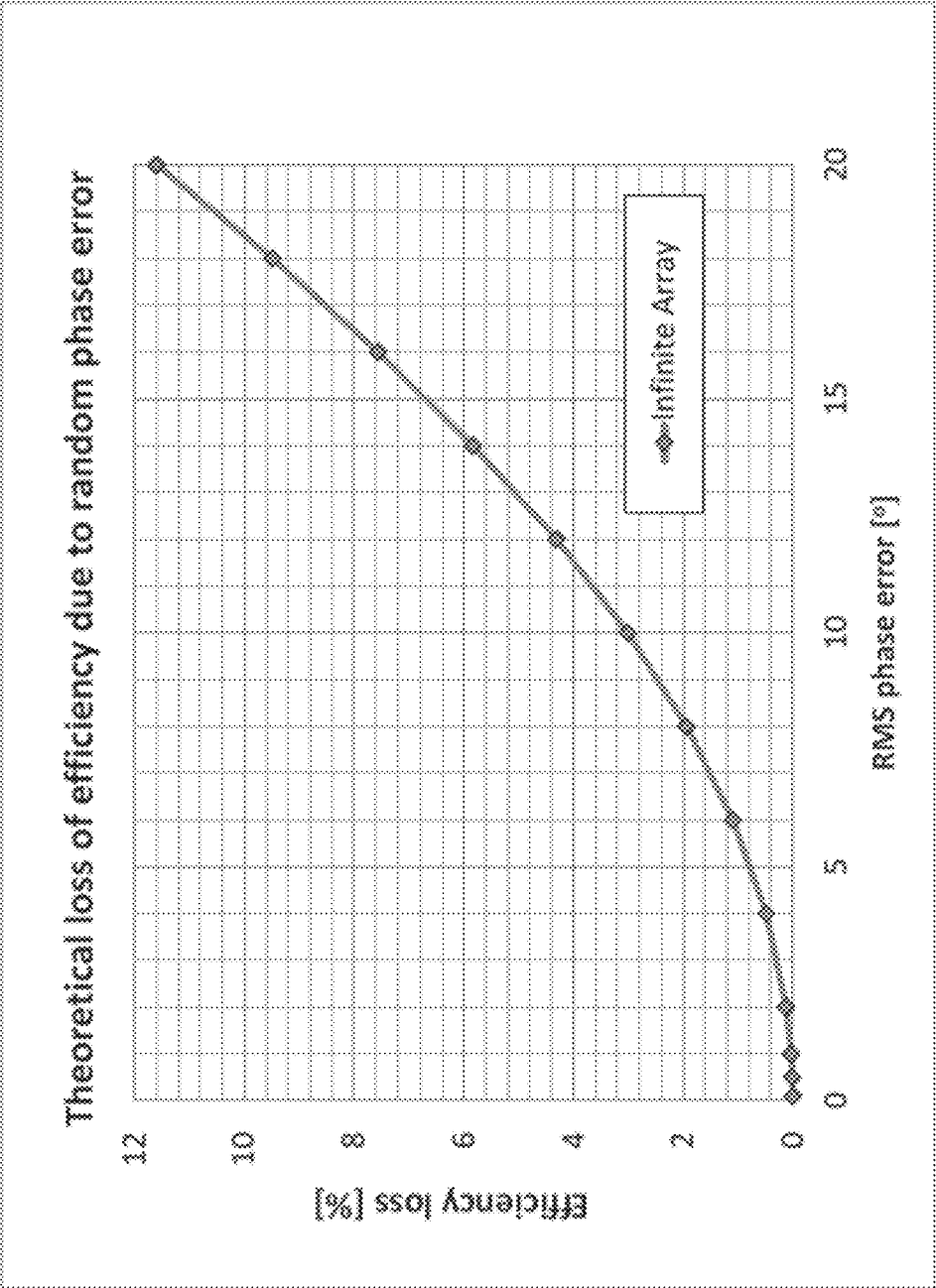
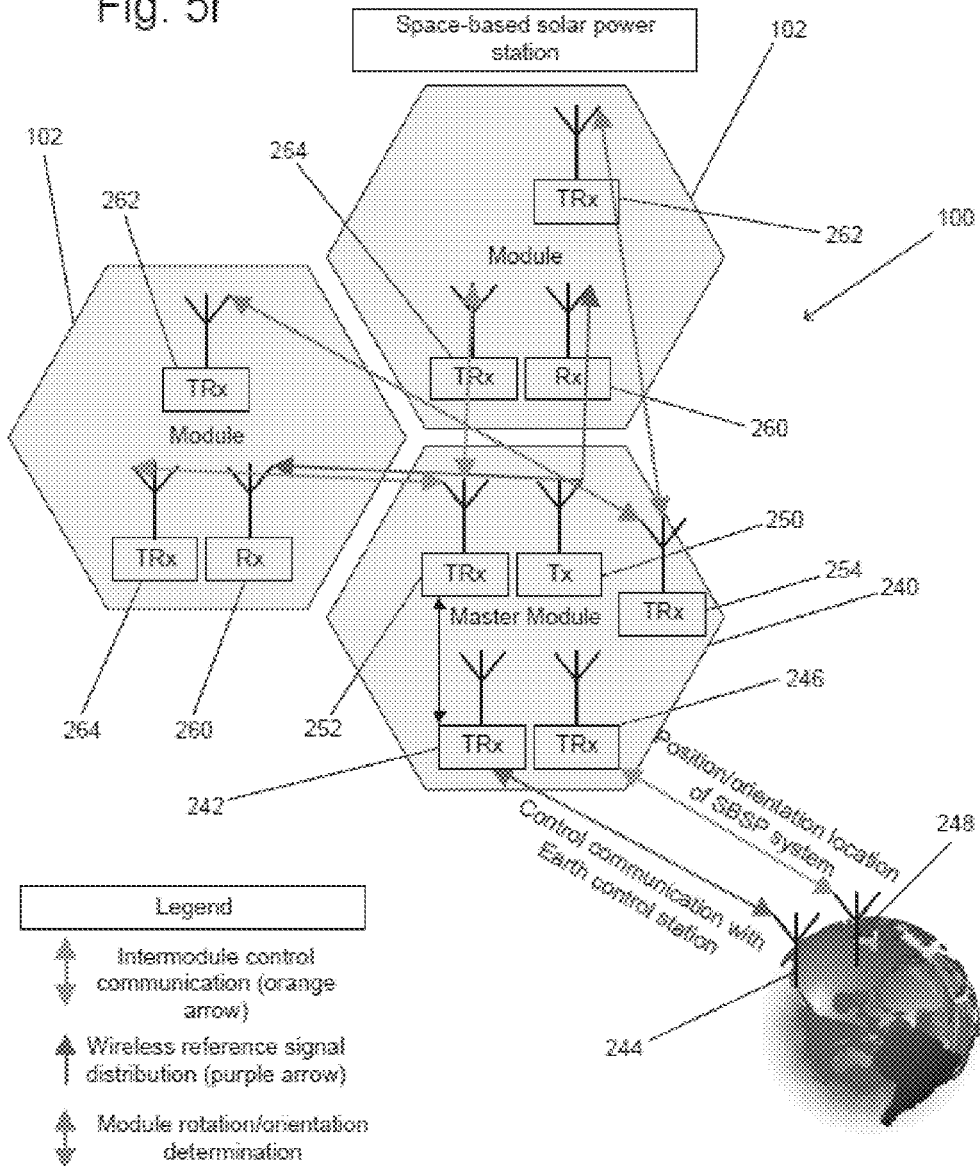

Fig. 5q

Fig. 5r



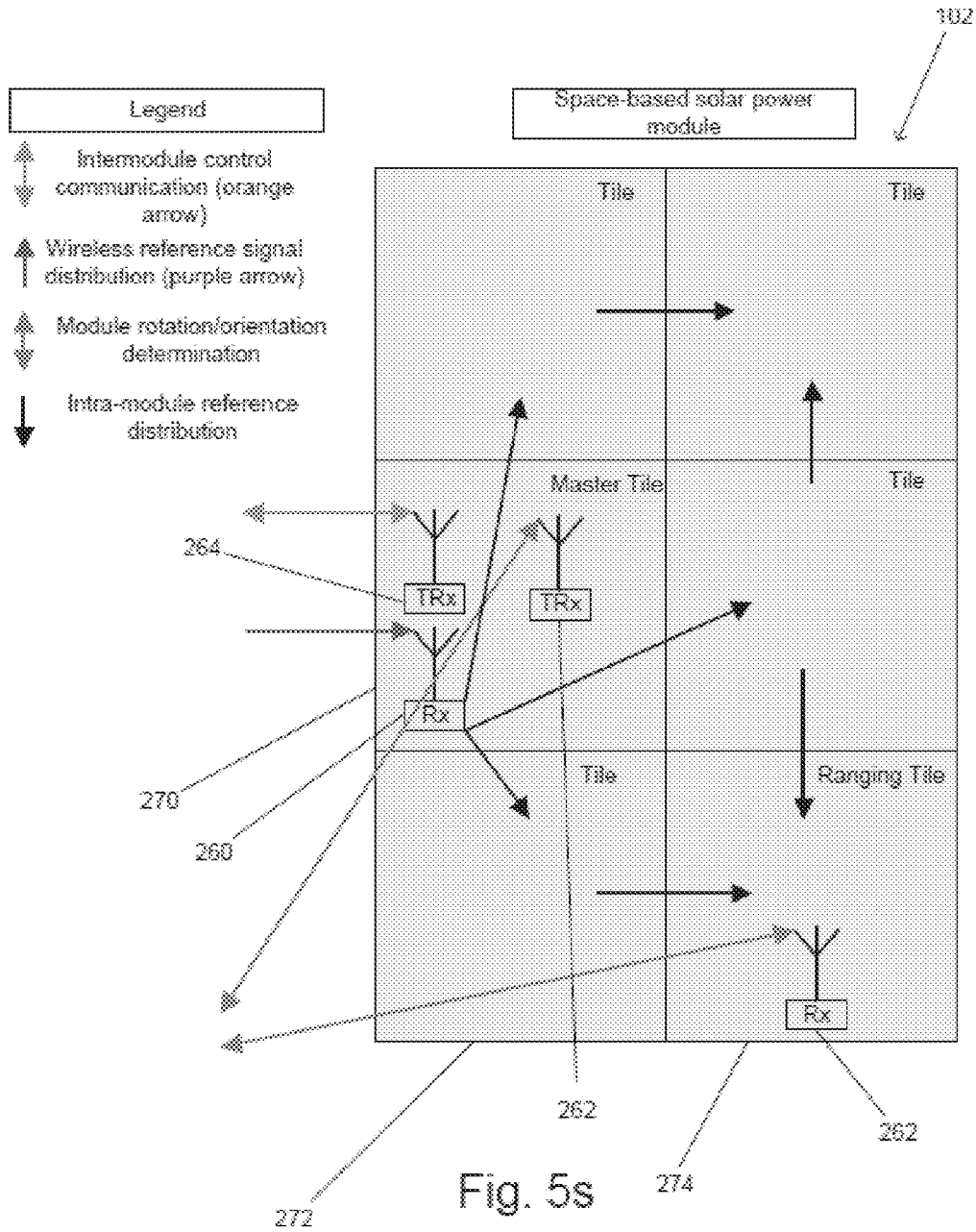
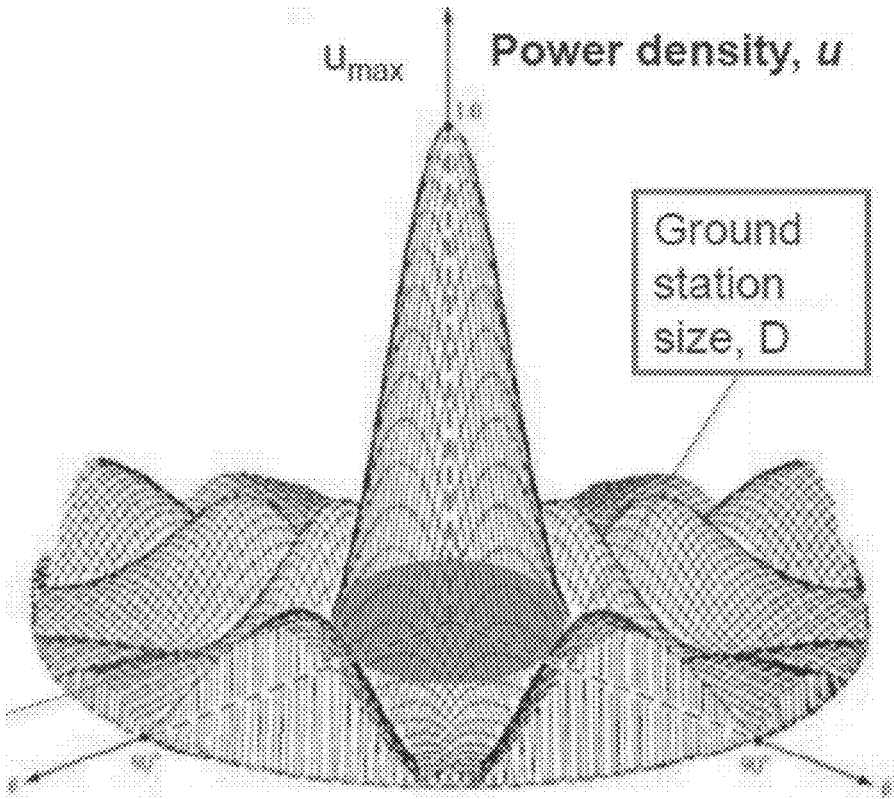

FIG. 6a



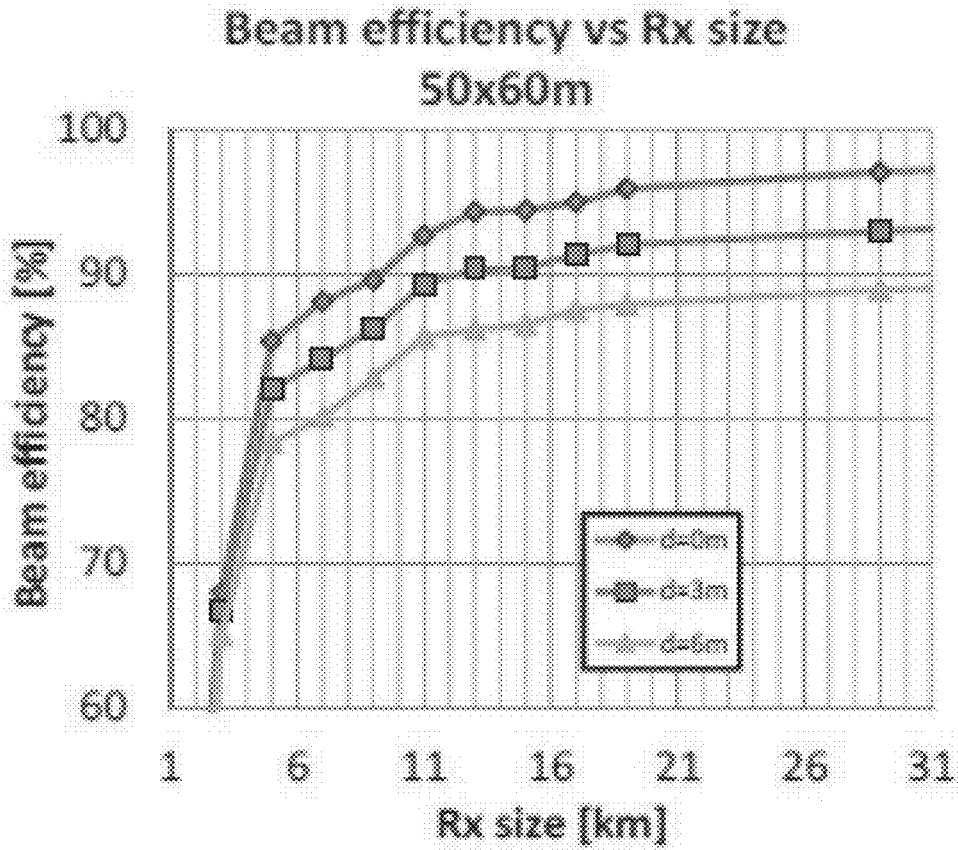

Fig. 6b

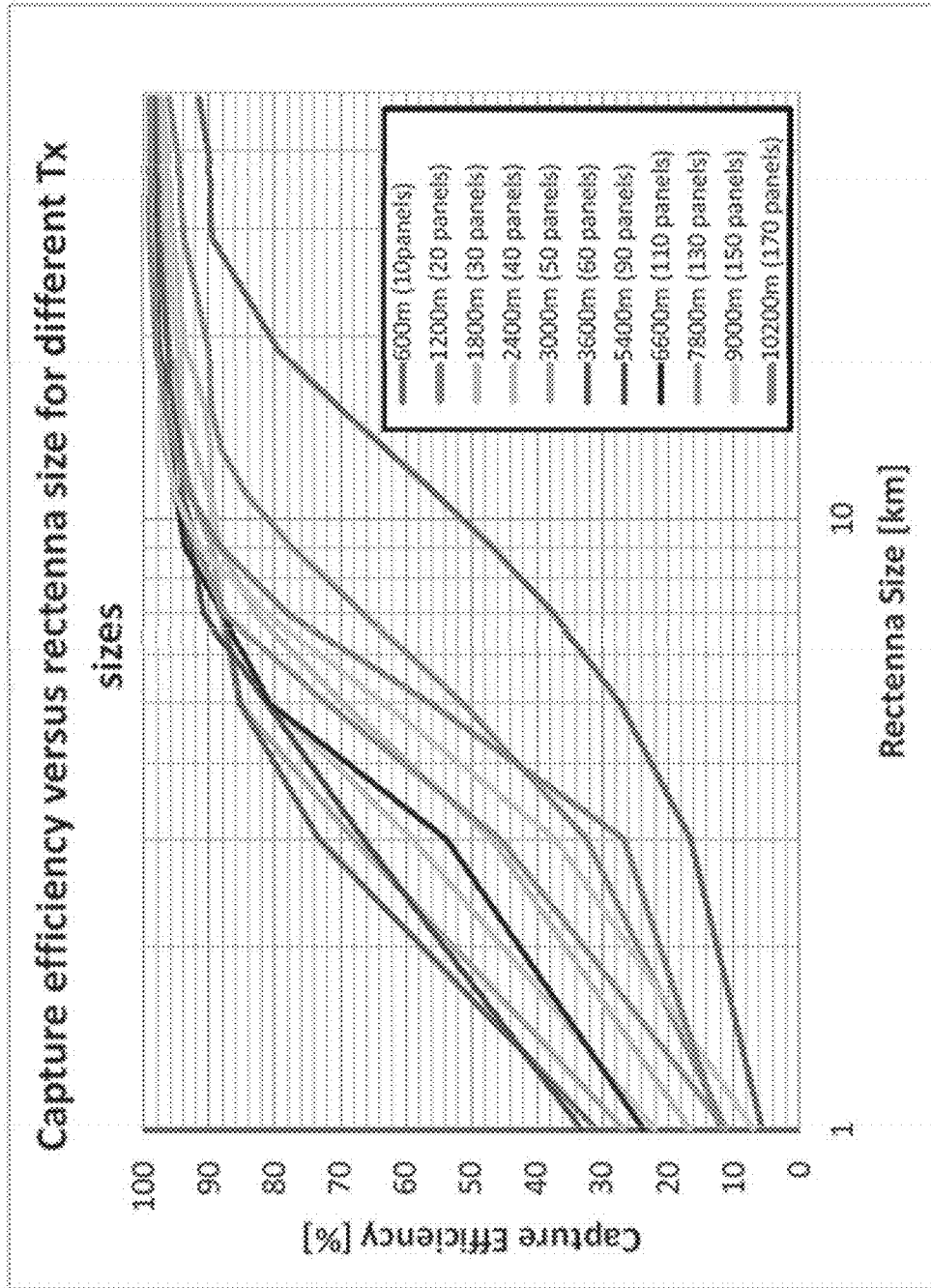

Fig. 6c

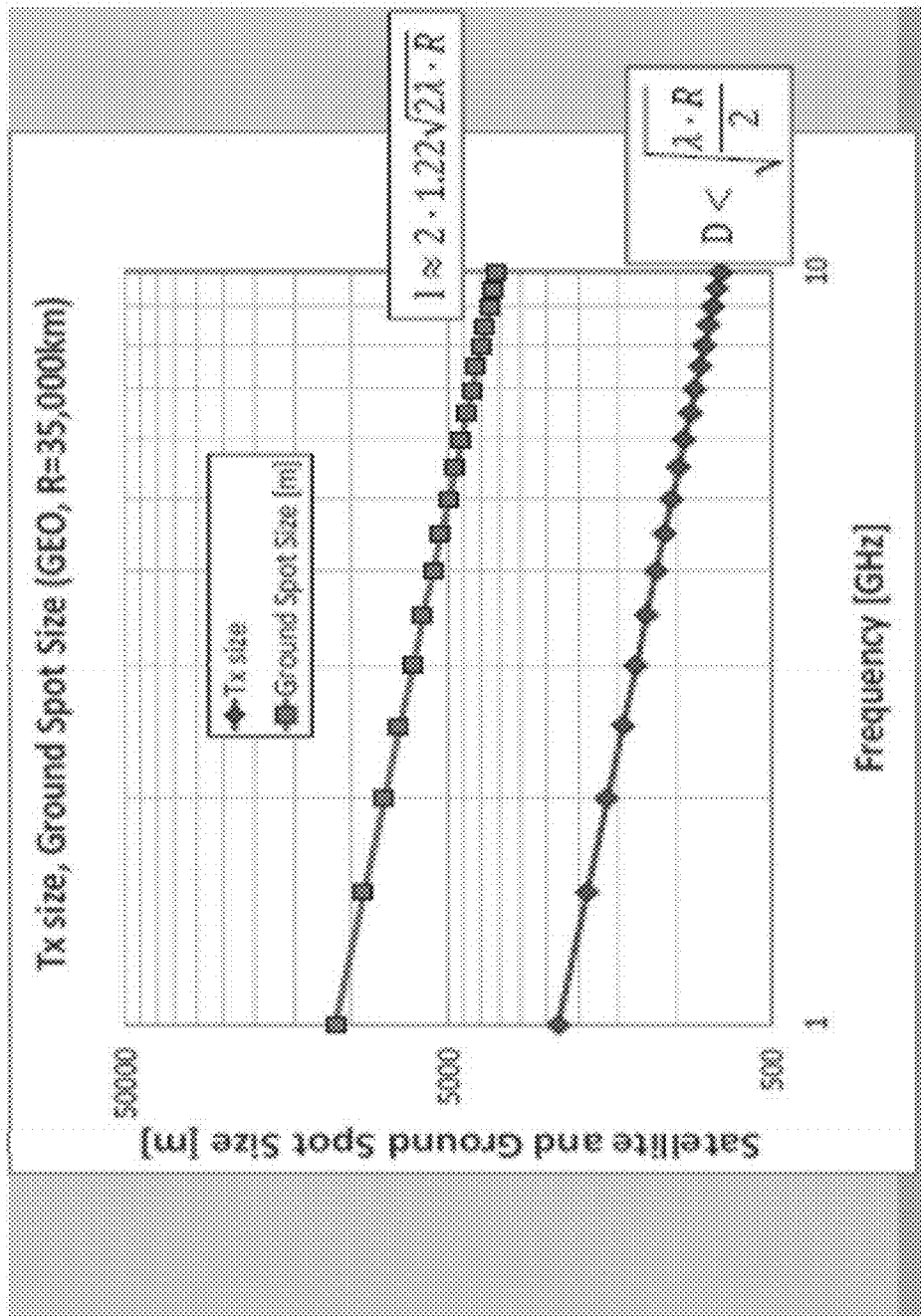

Fig. 6d

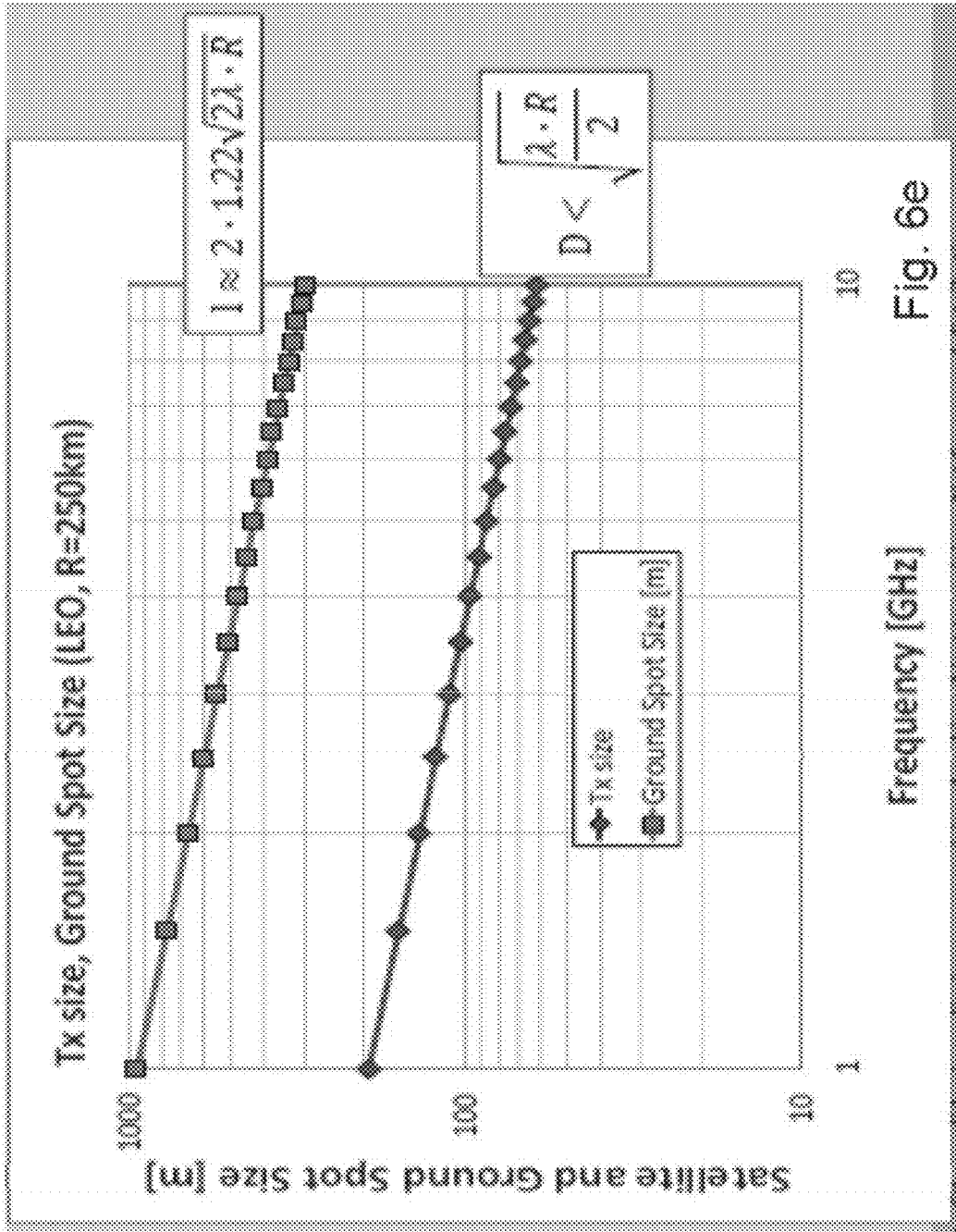

Fig. 6e

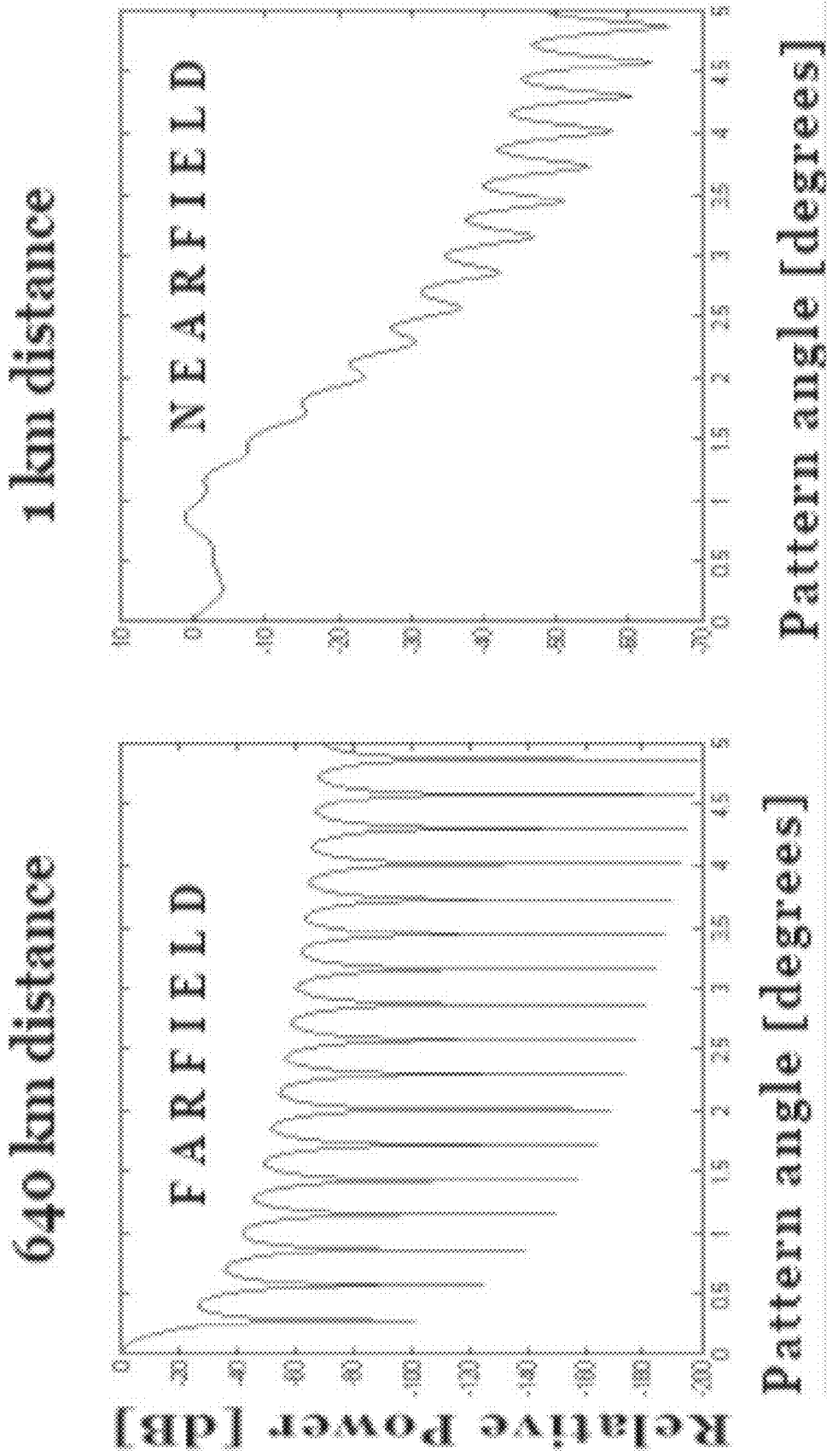

Fig. 6f

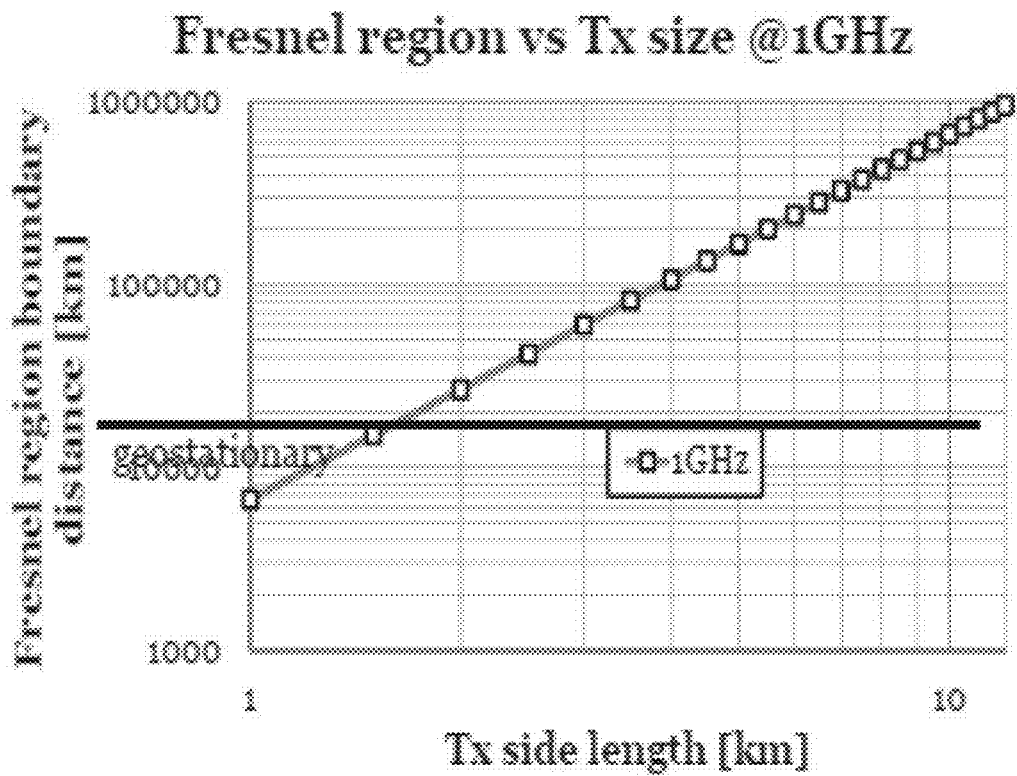

Fig. 6g

FIG. 7

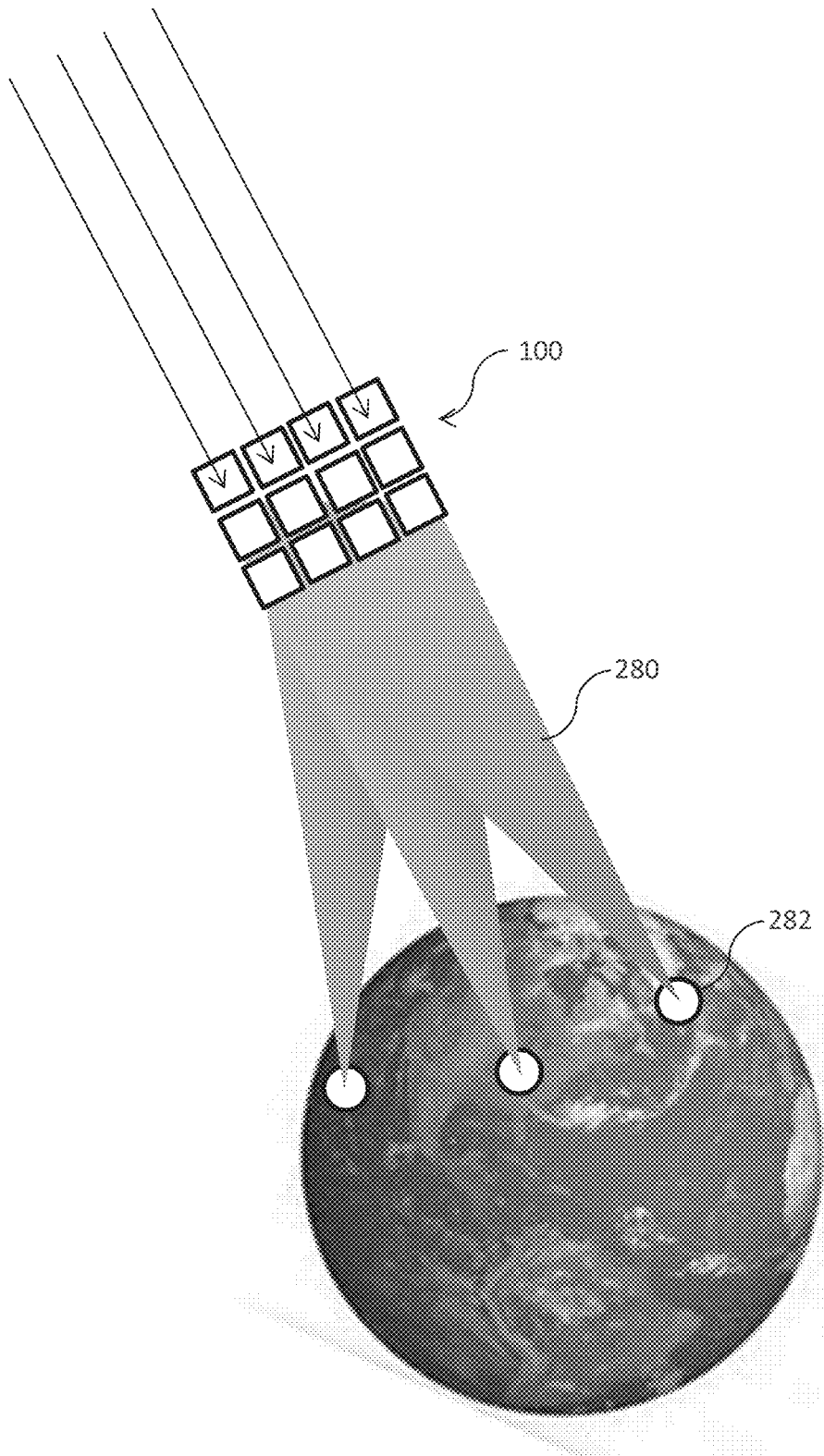

FIG. 8a

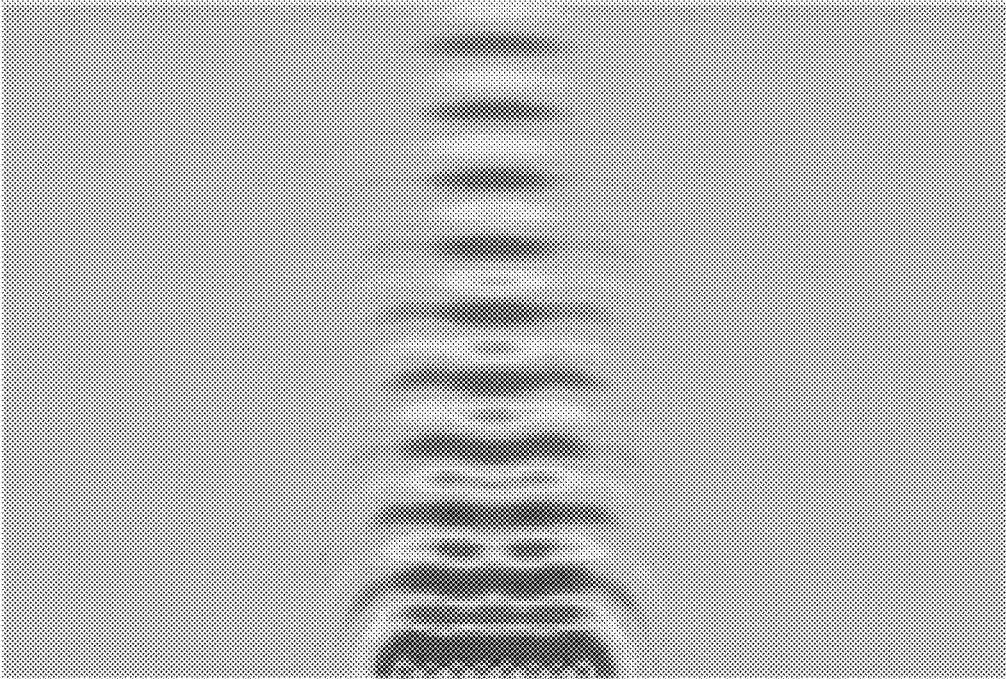

FIG. 8b

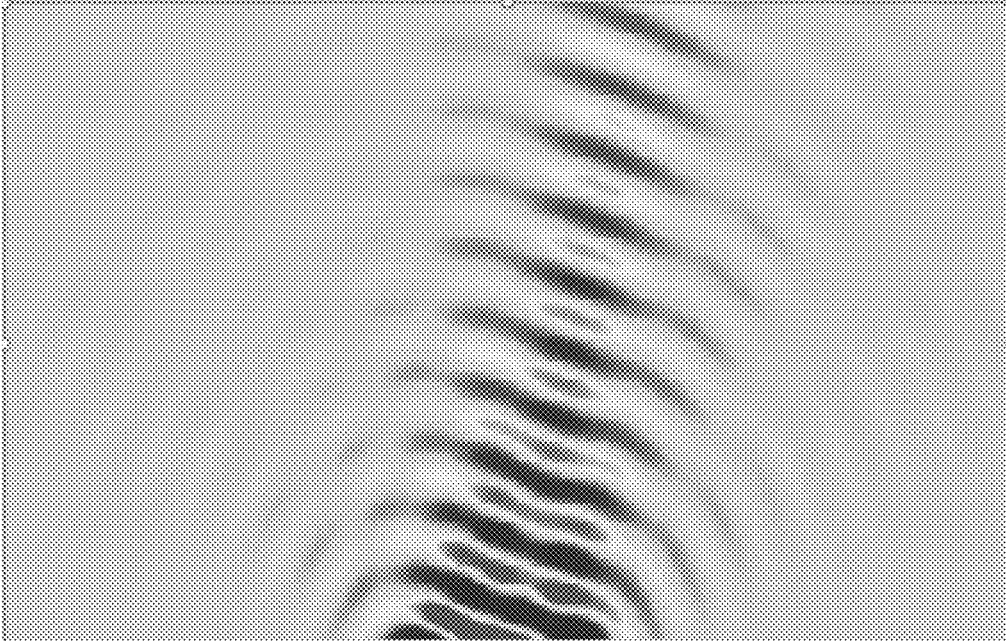

FIG. 9a

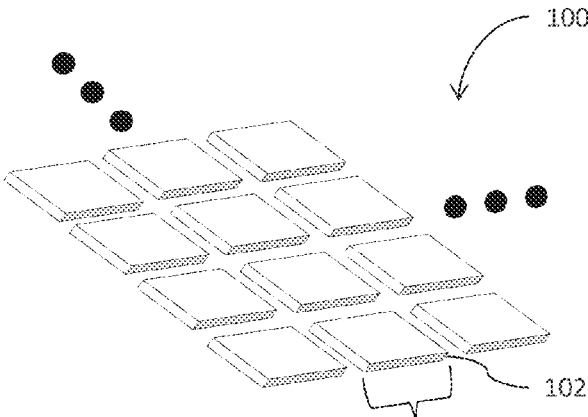
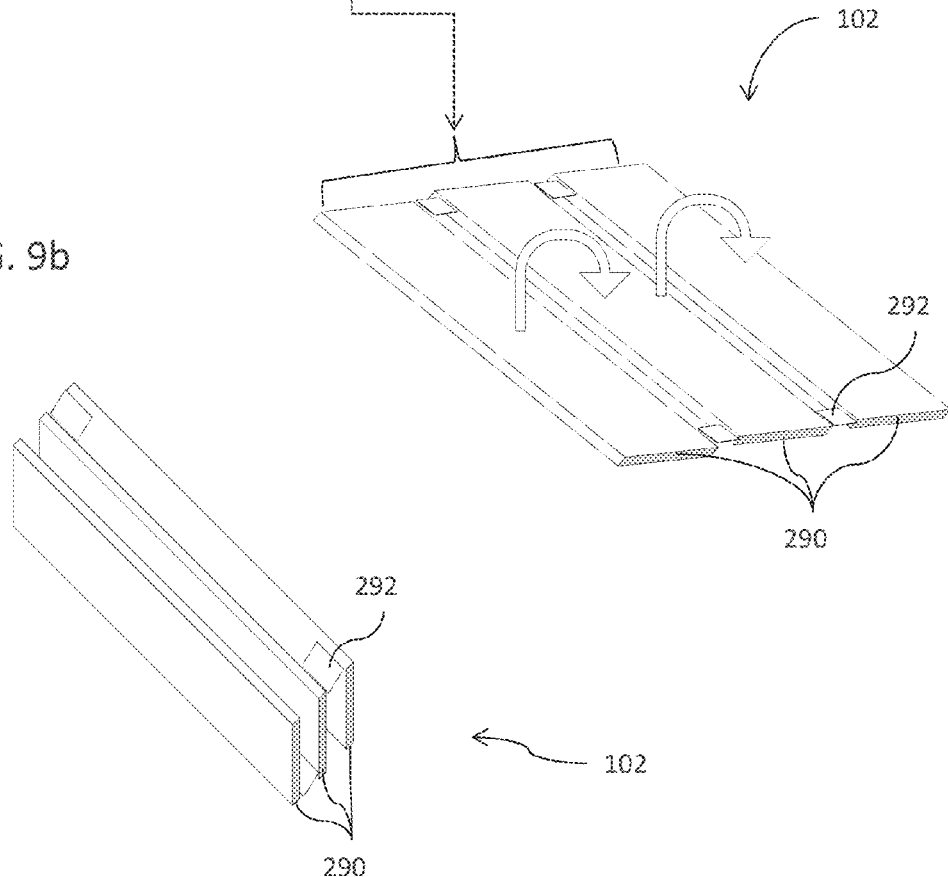

FIG. 9b



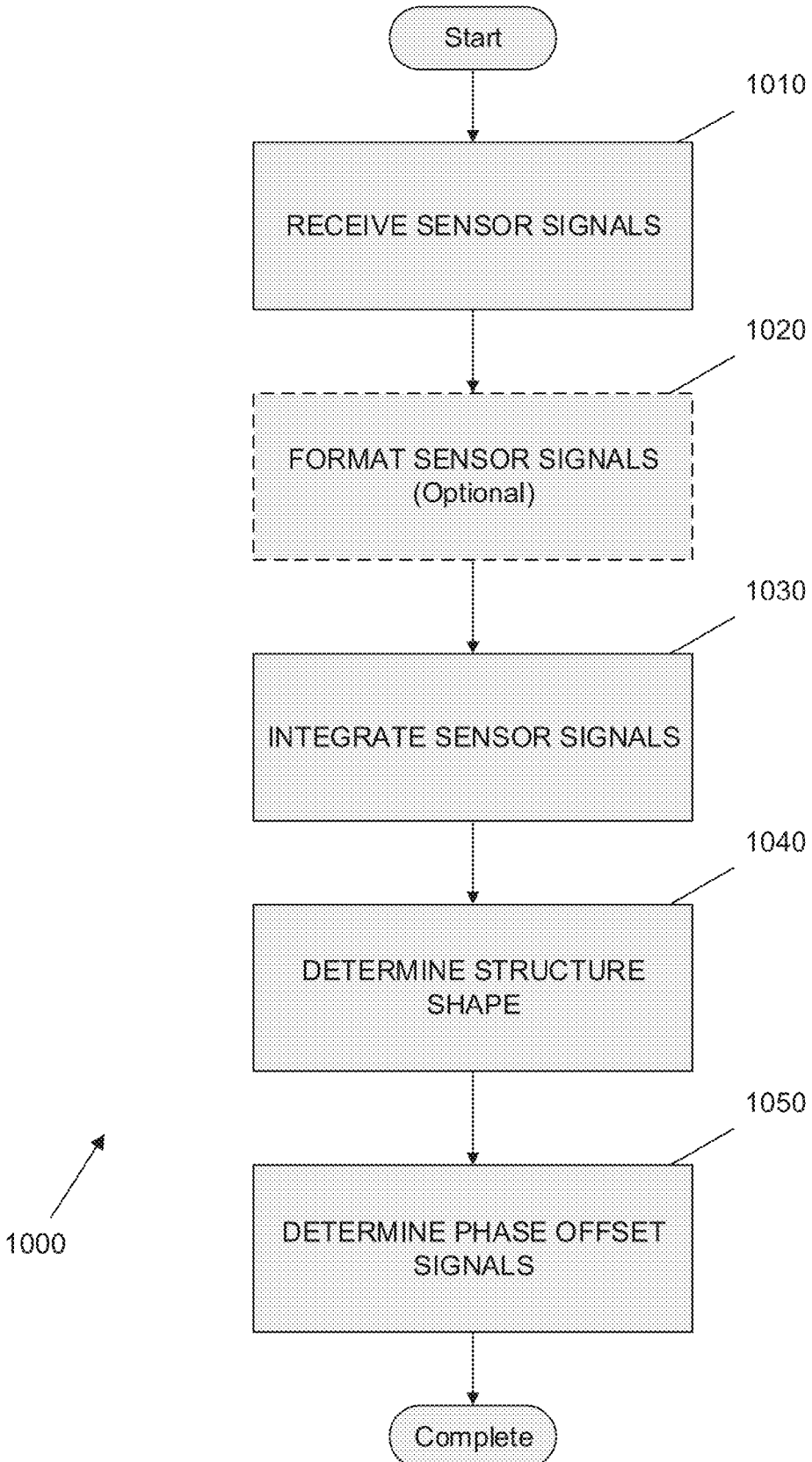

FIG. 10

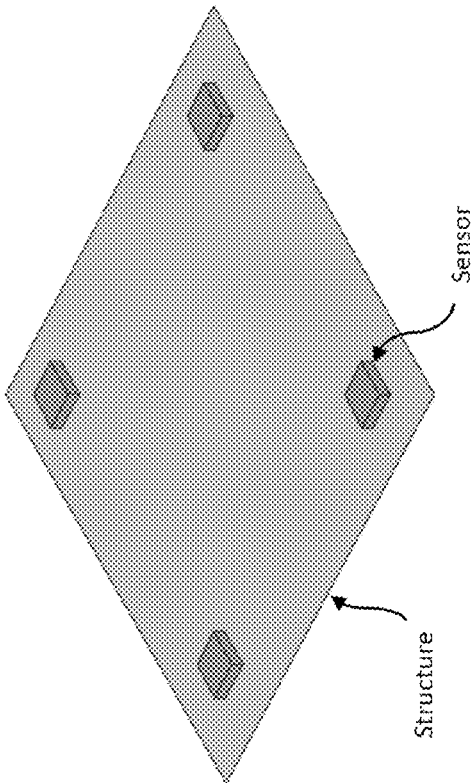

FIG. 11a

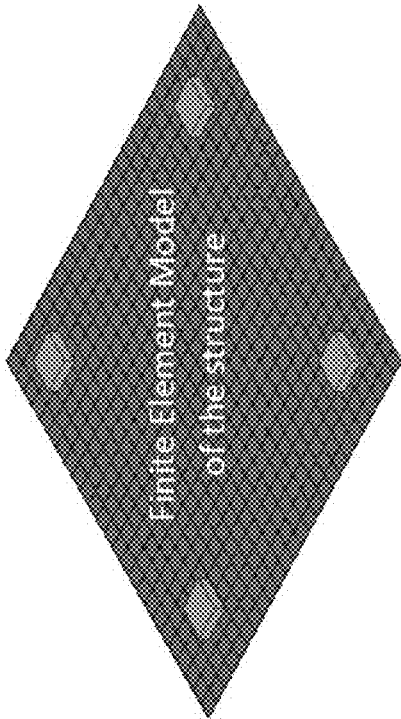

FIG. 11b

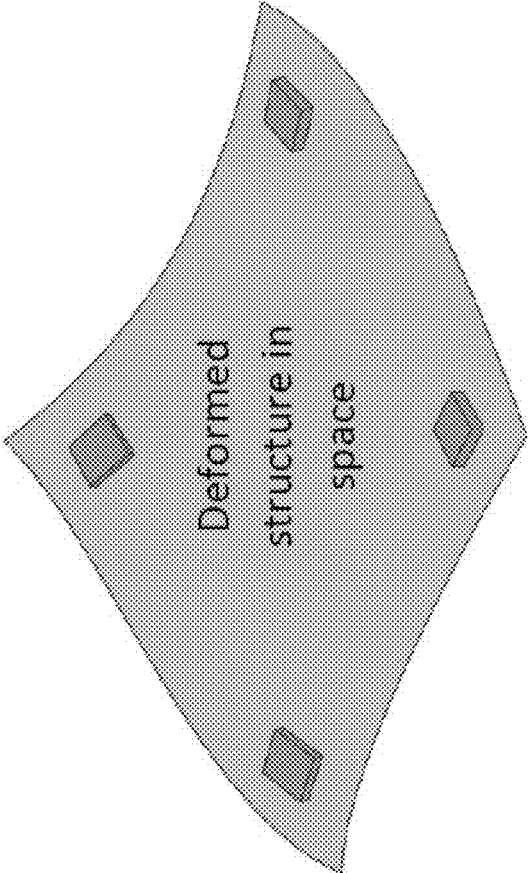

FIG. 11c

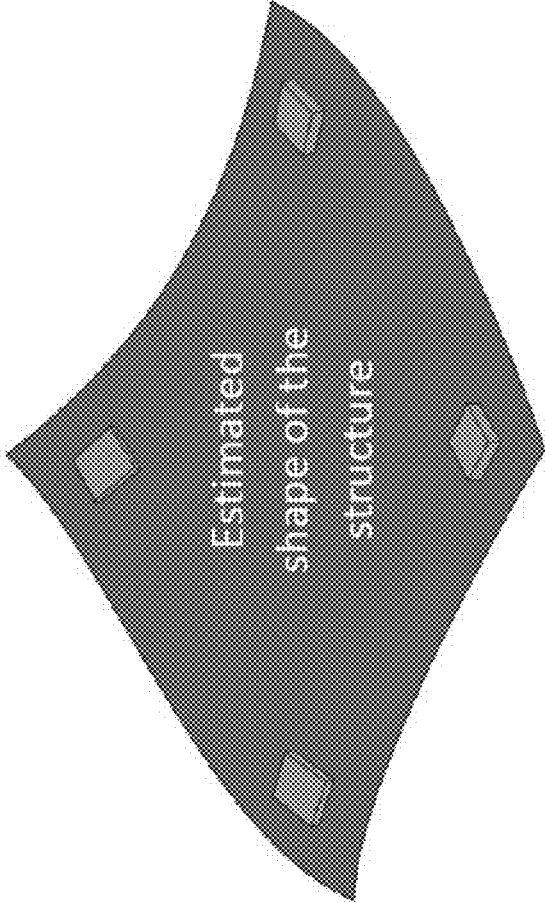

FIG. 11d

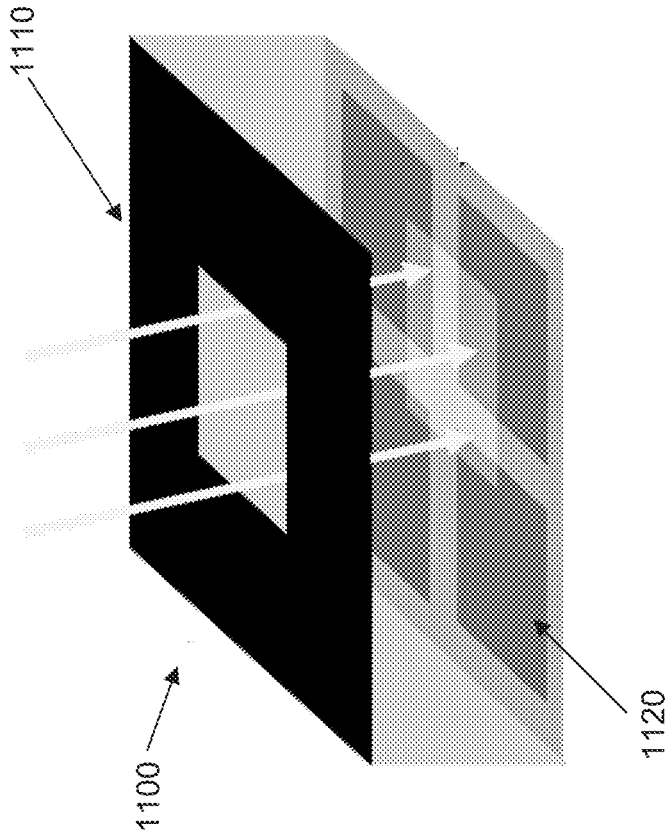

FIG. 11e

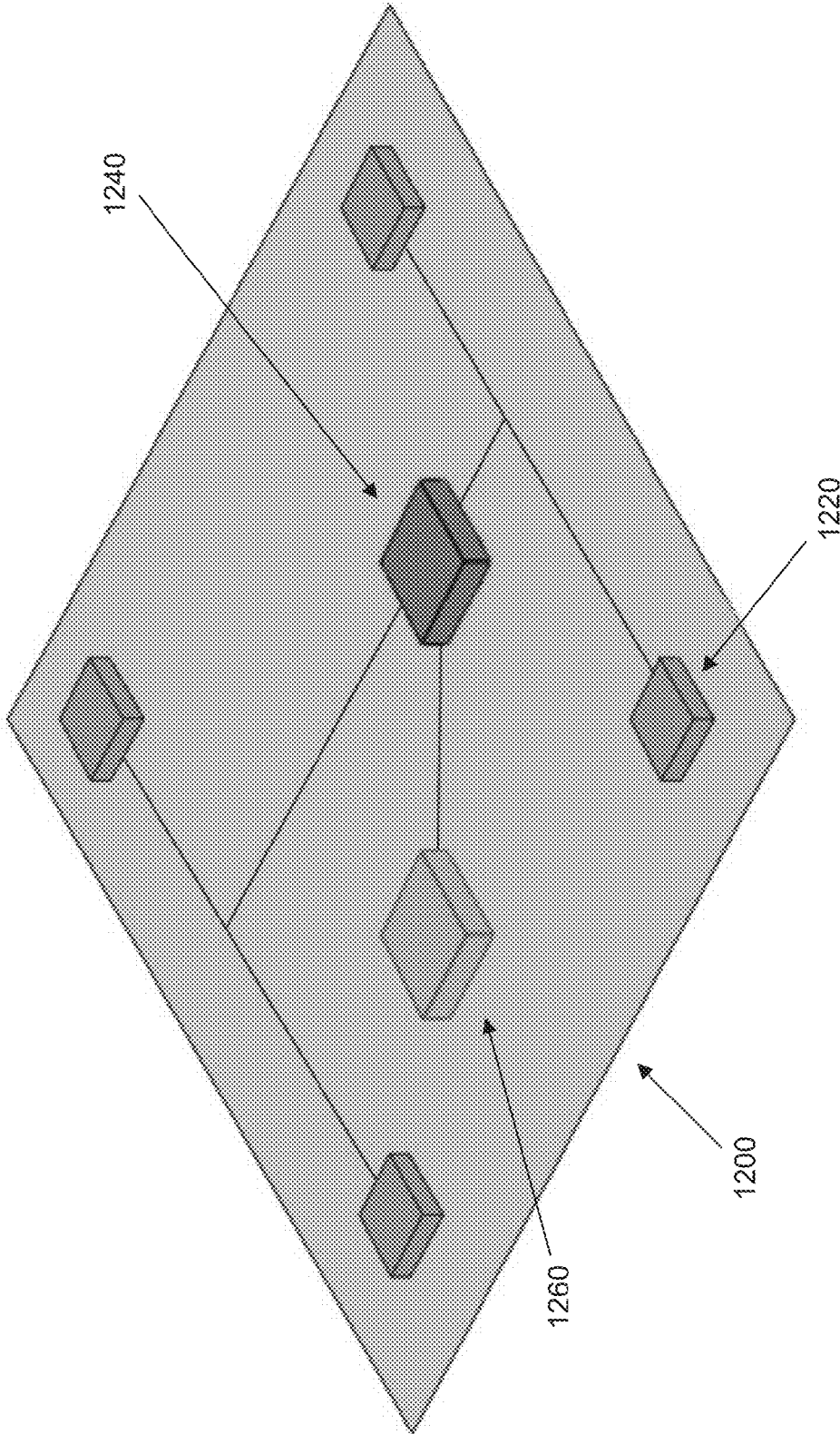

FIG. 12a

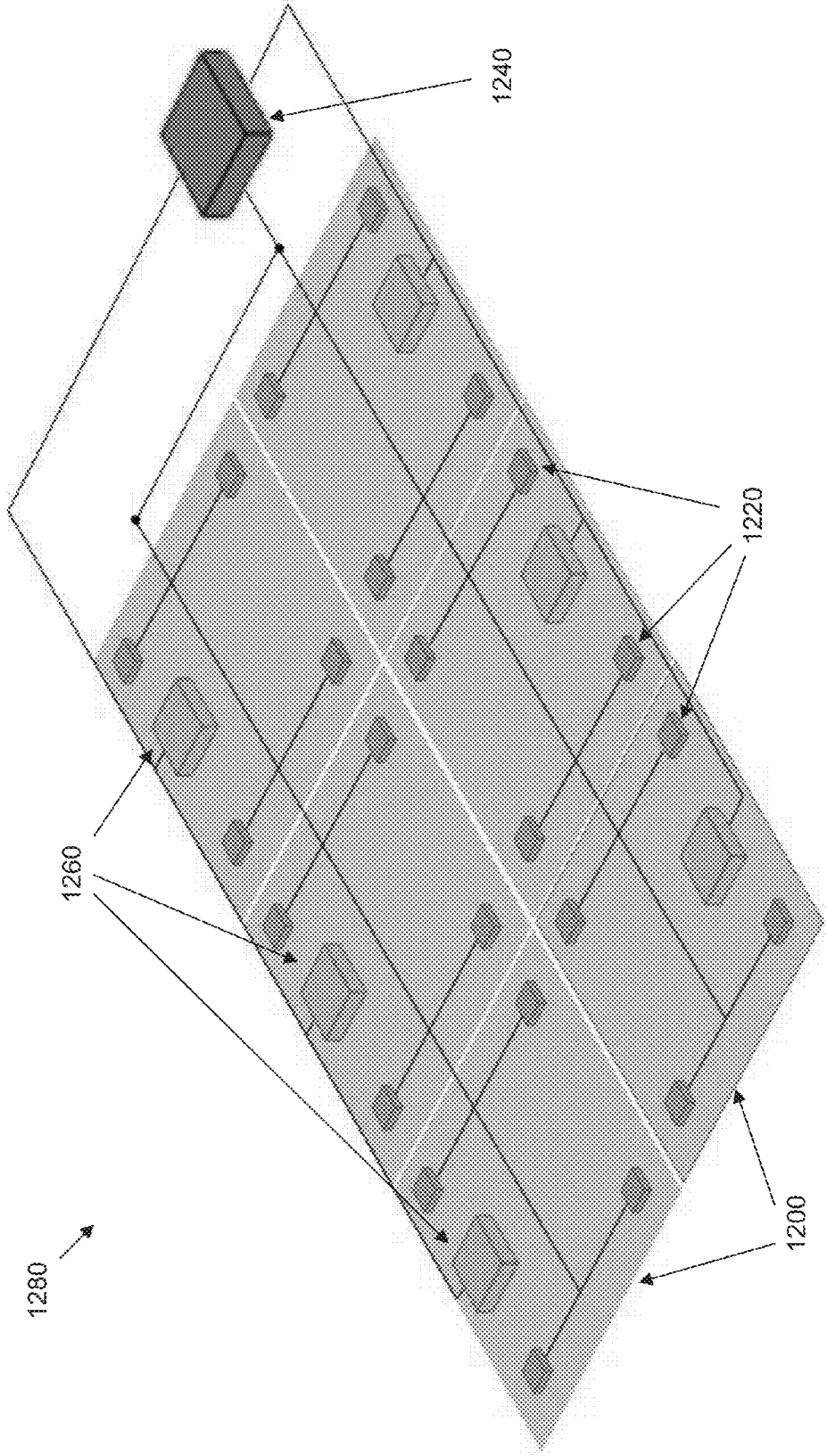

FIG. 12b

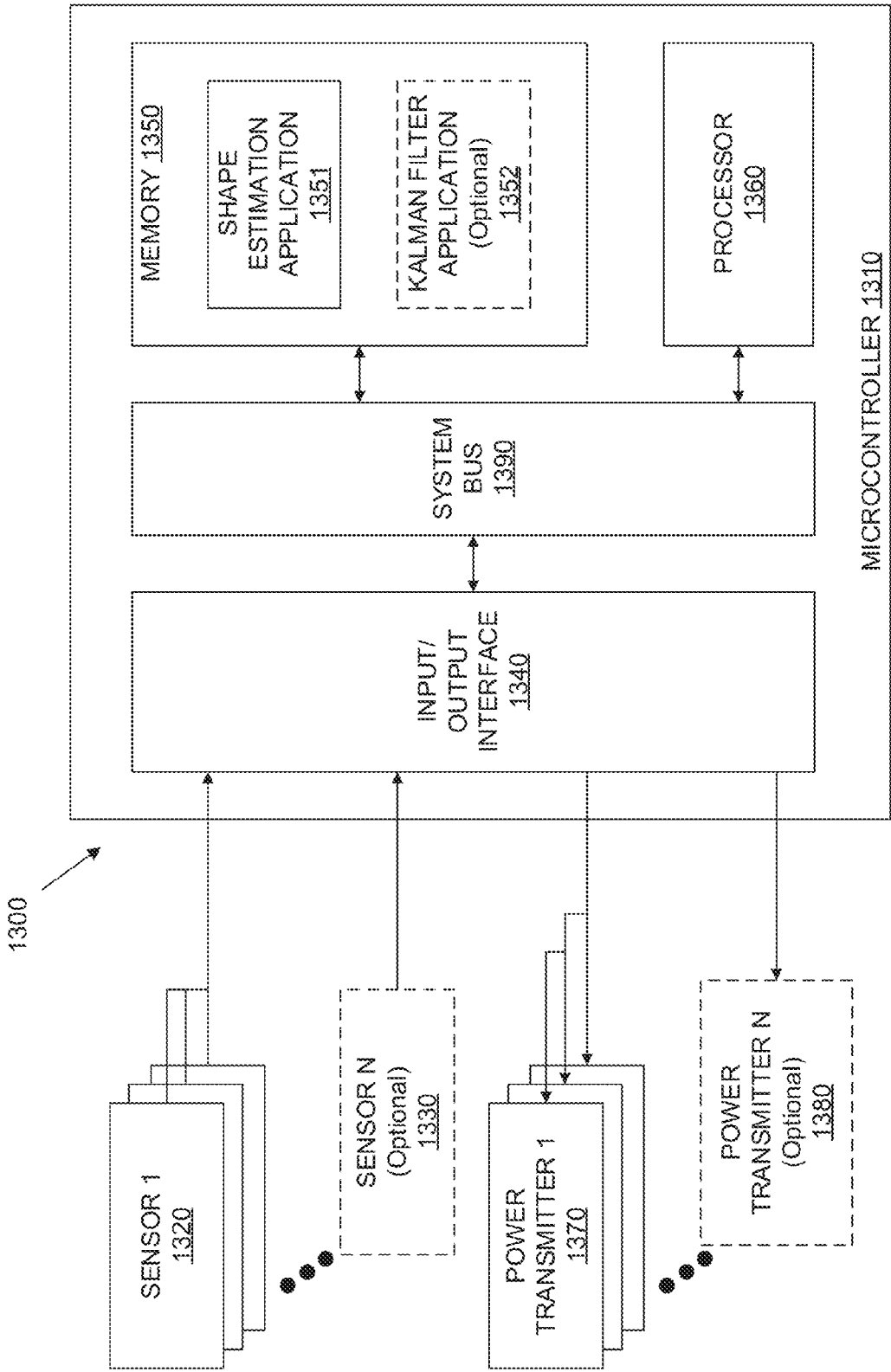

FIG. 13

**SYSTEMS AND METHODS FOR
PERFORMING SHAPE ESTIMATION USING
SUN SENSORS IN LARGE-SCALE
SPACE-BASED SOLAR POWER STATIONS**

RELATED APPLICATION

[0001] This application claims priority to U.S. provisional patent application Ser. No. 62/203,159 entitled “Space-based Solar Power System—2,” filed on Aug. 10, 2015; U.S. provisional patent application Ser. No. 62/220,017 entitled “Space-based Solar Power System—3,” filed on Sep. 17, 2015; U.S. provisional patent application Ser. No. 62/239,706 entitled “Space-based Solar Power System—4,” filed on Oct. 9, 2015; U.S. provisional patent application Ser. No. 62/264,500 entitled “Space-based Solar Power System—5,” filed on Dec. 8, 2015; U.S. provisional patent application Ser. No. 62/268,632 entitled “Space-based Solar Power System—6,” filed on Dec. 17, 2015; U.S. provisional patent application Ser. No. 62/270,425 entitled “Space-based Solar Power System—7,” filed on Dec. 21, 2015; U.S. provisional patent application Ser. No. 62/295,947 entitled “Space-based Solar Power System—8,” filed on Feb. 16, 2016; U.S. provisional patent application Ser. No. 62/320,819 entitled “Space-based Solar Power System—9,” filed on Apr. 11, 2016; U.S. provisional patent application Ser. No. 62/330,341 entitled “Space-based Solar Power System—10,” filed on May 2, 2016; U.S. provisional patent application Ser. No. 62/340,644 entitled “Space-based Solar Power System—11,” filed on May 24, 2016; U.S. provisional patent application Ser. No. 62/352,392 entitled “Space-based Solar Power System—12,” filed on Jun. 20, 2016; U.S. provisional patent application Ser. No. 62/366,720 entitled “Space-based Solar Power System—13,” filed on Jul. 26, 2016; all of which are incorporated by reference herein in their entirety.

FIELD OF THE INVENTION

[0002] The present invention is related to space-based solar power stations including multiple solar power satellite modules, and more specifically to the use of sun sensors to perform shape estimation when determining relative displacements of antennas configured in a phase array system in a satellite module and/or a space-based solar power system.

BACKGROUND

[0003] Space-based solar power (SBSP) describes the collection of solar power in space by a solar-power satellite or a satellite power system (SPS) and then the conversion and transmission of the power to a remote receiver for conversion back to electrical power. In an SBSP system, solar energy is collected as electrical energy on board, powering some manner of wireless power transmission to a receiver located remotely from the SBSP. The wireless power transmission application might include a microwave transmitter or laser emitter, which would direct its beam toward a collector, such as a power receiving rectenna at the remote location, such as, on the Earth’s surface.

[0004] SBSP differs from ground-based solar collection methods in that the means used to collect energy resides on an orbiting satellite instead of on the Earth’s surface. Basing such a system in space results in a higher collection rate for the solar energy due to the lack of a diffusing atmosphere.

Space-based solar power systems convert solar energy to a far-field emission such as microwaves outside the atmosphere, avoiding these losses. In addition, SBSP systems have a longer collection period and the ability to collect solar energy continuously without the downtime (and cosine losses, for fixed flat-plate collectors) that result from the Earth’s rotation away from the sun.

[0005] A general limitation for SBSP systems is the size of SPS required to generate sufficient electrical power from solar energy. For example, for a 500 MW system a 5 km² platform may be required. Such a platform would be formed of large satellites on the order to tens to hundreds of tonnes/satellite. The launch costs associated with placing such large structures into orbit reduces the economic viability of such SBSP systems.

SUMMARY

[0006] Systems and methods in accordance with various embodiments of the invention provide a space-based solar power (SBSP) system including a plurality of solar-power satellite modules. In a number of embodiments, the satellite modules include a plurality of modular power generation tiles combining at least one photovoltaic cell, a power transmitter and circuitry configured to perform a variety of control functions including (but not limited to) coordinating the participation of the power transmitter in an array. In several embodiments, satellite modules, panels and/or individual power generation tiles within the space-based solar power station are configured to wirelessly receive a reference signal and/or to distribute the reference signal to the power generation tiles within the space-based solar power station for the purposes of generating a coordinated wireless power transmission. In further embodiments, sun sensors can be placed on the power generation tiles to detect the intensity of illumination on the sensor, thereby determining the angle of the sun sensor with respect to the sun. In several more embodiments, these sun sensors are connected to a microprocessor that processes these sensor signals to determine the shape of the phase array. In further more embodiments, the determination of the shape and/or displacement of the phase array can be utilized to calculate phase offsets necessary to increase the efficiency of the phase array. In many further embodiments, these sun sensors may be used in conjunction with accelerometers, gyroscopes, and/or triangulation methods based upon received signals including, but not limited to, signals received from Global Positioning System satellites. In other embodiments, any of a variety of techniques for determining the shape of different elements of a space-based solar power station can be utilized as appropriate to the requirements of specific applications.

[0007] One embodiment of the invention includes: a plurality of unconnected satellite modules disposed in space in an orbital array formation; a plurality of power generation tiles disposed on each of the plurality of satellite modules; at least one photovoltaic cell disposed on each of the power generation tiles; and at least one power transmitter collocated with the at least one photovoltaic cell on each of the power generation tiles and in signal communication therewith such that an electrical current generated by the collection of solar radiation by the at least one photovoltaic cell powers the at least one power transmitter. In addition, each of the at least one power transmitters includes: an antenna; and control electronics that controls at least the phase of a radio frequency power signal that feeds the antenna so that

the power transmitter is coordinated with power transmitters on other power generation tiles to form a phased array; and at least one sun sensor disposed on the satellite module that is in signal communication with a microcontroller, where the microcontroller is in signal communication with the control electronics in each of the at least one power transmitter and provides a phase offset signal to the control electronics in each of the at least one power transmitter based upon at least one signal received from the at least one sun sensor.

[0008] In a further embodiment, the control electronics further controls the amplitude of the radio frequency power signal that feeds the antenna so that the power transmitter is coordinated with power transmitters on other power generation tiles.

[0009] In another embodiment, the power transmitter is configured to receive a reference signal, and the control electronics controls the phase of the radio frequency power signal by applying a phase shift with respect to the received reference signal.

[0010] In a still further embodiment, at least one of the satellite modules comprises a receiver to wirelessly receive the reference signal.

[0011] In still another embodiment, the receiver of the at least one of the satellite module is configured to wirelessly receive the reference signal from an Earth-based transmitter.

[0012] A yet further embodiment also includes a reference signal transmitter satellite comprising a transmitter that transmits the reference signal. In addition, the receiver of the at least one of the satellite module is configured to wirelessly receive the reference signal from transmitter on the reference signal transmitter satellite.

[0013] In a yet another embodiment the receiver to wirelessly receive the reference signal comprises an amplifier, and a cleanup phase locked loop.

[0014] In a further embodiment again, each of the at least one satellite module also includes transmission lines that route the reference signal to at least one power transmitter on a given satellite module.

[0015] In another embodiment again, the control electronics determine a phase shift to apply with respect to a received reference signal based upon location information.

[0016] In a further additional embodiment, the at least one signal from the at least one sun sensor comprises signals corresponding to the sensor's relative angle with respect to the sun.

[0017] In another additional embodiment, at least one accelerometer disposed on the satellite module that is in signal communication with the microcontroller.

[0018] In a still yet further embodiment, at least one gyroscope disposed on the satellite module that is in signal communication with the microcontroller.

[0019] In still yet another embodiment, the microcontroller is configured to integrate the at least one sun sensor signals to generate a finite model of the power generation tile.

[0020] In a still further embodiment again, the integration of the at least one sun sensor signals includes applying a Kalman filter to the at least one sun sensor signals.

[0021] In still another embodiment again, the integration of the at least one sun sensor signals includes applying an extended Kalman filter to the at least one sun sensor signals.

[0022] In a still further additional embodiment, the microcontroller is further configured to estimate the shape of the power generation tile with respect to the sun.

[0023] In still another additional embodiment, the microcontroller is further configured to estimate the relative position of the antennas in the power transmitters with respect to each other.

[0024] In a yet further embodiment again, the microcontroller is further configured to communicate a signal to the control electronics to adjust the reference signal based upon the estimated relative positions of the antennas in the power transmitters with respect to each other.

[0025] In yet another embodiment again, the control electronics is contained within an integrated circuit includes: an RF synthesizer configured to generate an RF signal based upon a received reference signal; a phase adjuster configured to phase shift an RF signal received from the RF synthesizer by an amount determined by a control signal; a power amplifier configured to amplify a phase shifted RF signal received from the phase adjuster; and a digital signal processor configured by software stored in memory to generate the control signal for the phase adjuster.

[0026] A yet further additional embodiment includes: a plurality of power generation tiles; at least one photovoltaic cell disposed on each of the power generation tiles; and at least one power transmitter collocated with the at least one photovoltaic cell on each of the power generation tiles and in signal communication therewith such that an electrical current generated by the collection of solar radiation by the at least one photovoltaic cell powers the at least one power transmitter. In addition, each of the at least one power transmitters includes: an antenna; and control electronics that controls at least the phase of a radio frequency power signal that feeds the antenna so that the power transmitter is coordinated with power transmitters on other power generation tiles to form a phased array; at least one sun sensor disposed on the satellite module that is in signal communication with a microcontroller, where the microcontroller is in signal communication with the control electronics of the at least one power transmitter therewith such that a phase offset signal to the control electronics in each of the at least one power transmitter based upon at least one signal received from the at least one sun sensor.

[0027] Yet another additional embodiment includes: at least one photovoltaic cell; and at least one power transmitter collocated with the at least one photovoltaic cell and in signal communication therewith such that an electrical current generated by the collection of solar radiation by the at least one photovoltaic cell powers the at least one power transmitter. In addition, each of the at least one power transmitters includes: an antenna; and control electronics that controls at least the phase of a radio frequency power signal that feeds the antenna; and at least one sun sensor in signal communication with a microcontroller, where the microcontroller is in signal communication with the control electronics of the at least one power transmitter therewith such that a phase offset signal to the control electronics in each of the at least one power transmitter based upon at least one signal received from the at least one sun sensor.

[0028] The features and advantages described in the specification are not all inclusive and, in particular, many additional features and advantages will be apparent to one of ordinary skill in the art in view of the drawings, specification, and claims. Moreover, it should be noted that the language used in the specification has been principally

selected for readability and instructional purposes, and may not have been selected to delineate or circumscribe the inventive subject matter.

BRIEF DESCRIPTION OF DRAWINGS

[0029] The description will be more fully understood with reference to the following figures and data graphs, which are presented as various embodiments of the disclosure and should not be construed as a complete recitation of the scope of the disclosure, wherein:

[0030] FIG. 1 conceptually illustrates a large-scale space-based solar power station with a plurality of power satellite modules in orbit about the Earth, according to one embodiment.

[0031] FIG. 2 conceptually illustrates a large-scale space-based solar power station with a plurality of power satellite modules flying in a rectangular orbital formation, according to one embodiment.

[0032] FIG. 3 conceptually illustrates a large-scale space-based solar power station, a satellite module, and a cross-sectional view of a modular power generation tile, according to one embodiment.

[0033] FIG. 4a conceptually illustrates a cross-sectional view of a modular power generation tile, according to one embodiment.

[0034] FIG. 4b conceptually illustrates a cross-sectional view of a photovoltaic cell, according to one embodiment.

[0035] FIG. 4c conceptually illustrates a block-diagram for an integrated circuit suitable for utilization in a power transmitter forming part of a power generation tile, according to one embodiment.

[0036] FIGS. 4d and 4e conceptually illustrate wiring of a power generation tile, according to one embodiment.

[0037] FIGS. 5a-5c conceptually illustrate an array of power generation tiles in which the antenna elements of the power generation tiles are configured as a phased array, according to one embodiment.

[0038] FIG. 5d conceptually illustrates a process for distributing a reference signal between the sub-arrays formed by each of the satellite modules in a space-based solar power station, according to one embodiment.

[0039] FIG. 5e conceptually illustrates movement and/or rotation of individual satellite modules in a space-based solar power station.

[0040] FIG. 5f conceptually illustrates the transmission of a reference signal to satellite modules within a space-based solar power station by a transmitter, according to one embodiment.

[0041] FIG. 5g conceptually illustrates a satellite module including an antenna to receive a transmitted reference signal, a low noise amplifier to increase the amplitude of the received reference signal, and a clean-up PLL to generate a low noise reference signal that is output to the power generation tiles within the satellite module, according to one embodiment.

[0042] FIG. 5h conceptually illustrates an implementation of a clean-up PLL incorporating a low-noise voltage controlled oscillator, according to one embodiment.

[0043] FIG. 5i conceptually illustrates the manner in which a clean-up PLL can band limit noise from a received reference signal thereby improving signal-to-noise ratio of the reference signal.

[0044] FIG. 5j conceptually illustrates the minimum transmitter power required when utilizing a space-based reference transmitter to transmit a reference signal, according to one embodiment.

[0045] FIG. 5k conceptually illustrates the required gain and aperture size for a receiver that receives a reference signal transmitted by an Earth-based transmitter, according to one embodiment.

[0046] FIG. 5l conceptually illustrates the redistribution of a reference signal and the cascading of jitter.

[0047] FIG. 5m illustrates the results of simulations of the effect of jitter on the efficiency of power transmission by a 75 m×60 m space-based solar array at 1 GHz based upon the size of the rectenna array receiver.

[0048] FIG. 5n conceptually illustrates the routing of a reference signal amongst power generation tiles, according to one embodiment.

[0049] FIG. 5o conceptually illustrates determination of location using a signal or signals transmitted by an Earth-based transmitter or transmitters, according to one embodiment.

[0050] FIG. 5p conceptually illustrates a process for distributing location information in a hierarchical fashion between satellite modules, panels and/or tiles within the space-based solar power station according to one embodiment.

[0051] FIG. 5q conceptually illustrates the impact of the RMS phase error in an antenna array on efficiency, according to one embodiment.

[0052] FIG. 5r conceptually illustrates a space-based solar power station that includes at least one master satellite module configured to coordinate the receipt and distribution of a reference signal, location information, and command and control information, according to one embodiment.

[0053] FIG. 5s conceptually illustrates the use of different classes of power generation tiles to coordinate distribution of reference signals, location information, and/or command and control information within a satellite module, according to one embodiment.

[0054] FIG. 6a conceptually illustrates the power density distribution at a ground receiver from a transmission of power from a phased array of antennas on a solar power station, according to embodiments.

[0055] FIG. 6b conceptually illustrates the increase in efficiency of power transmission systems that utilize different spacing of transmit antennas with the increased size of the receiver array.

[0056] FIG. 6c conceptually illustrates the manner in which the efficiency of power transmission is impacted by both the size of the array of antenna elements utilized to form the ground spot and the size of the rectenna array utilized to receive the transmitted power.

[0057] FIGS. 6d and 6e conceptually illustrate the manner in which the frequency of the transmitted power signal impacts the spot size of the maximum power lobe generated by space-based solar power stations located in geosynchronous and Low Earth Orbits (LEO).

[0058] FIG. 6f conceptually illustrates that the pattern angle of the radiation pattern of an antenna in the near-field is much larger than the pattern angle of the radiation pattern of the antenna array in the far-field.

[0059] FIG. 6g conceptually illustrates the relationship between the Fresnel region boundary and the size of the transmitter array at 1 GHz.

[0060] FIG. 7 conceptually illustrates dynamic power allocation from a large-scale space-based solar power system, according to one embodiment.

[0061] FIGS. 8a and 8b conceptually illustrate electronic beam steering using relative phase offset between elements of a phased array, according to one embodiment.

[0062] FIG. 9a conceptually illustrates a large-scale space-based solar power station and a compactable satellite module in a deployed configuration, according to embodiments.

[0063] FIG. 9b conceptually illustrates a retracted compactable satellite module, according to FIG. 9a in a retracted configuration.

[0064] FIG. 10 is a flow chart illustrating a process for determining an estimate for the shape of a structure in space in accordance with an embodiment of the invention.

[0065] FIG. 11a conceptually illustrates a power generation tile with sun sensors in accordance with an embodiment of the invention.

[0066] FIG. 11b conceptually illustrates a finite element model of a power generation tile in accordance with an embodiment of the invention.

[0067] FIG. 11c conceptually illustrates a deformed power generation tile with sun sensors in accordance with an embodiment of the invention.

[0068] FIG. 11d conceptually illustrates a model of the estimated shape of the power generation tile in accordance with an embodiment of the invention.

[0069] FIG. 11e conceptually illustrates a sun sensor in accordance with an embodiment of the invention.

[0070] FIG. 12a conceptually illustrates a power generation tile with sun sensors and a microcontroller in accordance with an embodiment of the invention.

[0071] FIG. 12b conceptually illustrates an array of power generation tiles with sun sensors connected to a microcontroller in accordance with an embodiment of the invention.

[0072] FIG. 13 conceptually illustrates a microcontroller in accordance with an embodiment of the invention.

DETAILED DESCRIPTION

[0073] Turning now to the drawings, large-scale space-based solar power (SBSP) stations in accordance with various embodiments of the invention are illustrated. In many embodiments, the SBSP systems include arrays of independent satellite modules each incorporating arrays of independent solar electric power generation tiles. In several embodiments, the power generation tiles are each formed incorporating independent photovoltaic cells, power transmitters, and control circuits. In further embodiments, sun sensors can be utilized to perform shape estimation and to generate phase offsets for use in a phased array system. The satellite modules and power generation tiles may be formed from compactable structures according to some embodiments. Methods for deploying, stabilizing, operating and constructing such large-scale space-based solar power systems in accordance with a number of embodiments of the invention are also described.

[0074] A large-scale space-based solar power station is a modular space-based construct that can be formed from a plurality of independent satellite modules placed into orbit within an orbital formation such that the position of each satellite module relative to each other is known. Each of the satellite modules can include a plurality of power generation tiles that capture solar radiation as electrical current and use

the current to transmit the energy to one or more remote receivers using power transmitters. In many instances, the transmissions are generated using microwave power transmitters that are coordinated to act as a phased- and/or amplitude modulated array capable of generating a steerable beam and/or focused beam that can be directed toward one or more remote receivers. In other embodiments, any of a variety of appropriate power transmission technologies can be utilized including (but not limited to) optical transmitters such as lasers.

[0075] Some lightweight space structures are used in the construction of the power generation tiles and/or satellite modules and may incorporate movable elements that allow the lightweight space structure to be compacted prior to deployment to reduce the area or dimensional length, height and/or width of the power generation tiles and/or satellite modules prior to deployment. The space structures may be made of any number, size and configuration of movable elements, and the elements may be configured to compact according to any suitable compacting mechanism or configuration, including one or two-dimensional compacting using, among others, z-folding, wrapping, rolling, fan-folding, double z-folding, Miura-ori, slip folding, wrapping, and combinations thereof. Movable elements can be interrelated by hinges, such as, frictionless, latchable, ligament, and slippage hinges, among others. Many structures are prestressed and/or provided with supportive frameworks to reduce out-of-plane macro- and micro-deformation of the lightweight structures. Structures and modules may include dynamic stabilizing movement (e.g., spinning) during deployment and/or operation. Deployment mechanisms to deploy the compactible lightweight structures into a deployed operational state may be incorporated into or associated with embodiments of the lightweight structures. Some deployment mechanisms may include (but are not limited to) expansive boom arms, centrifugal force mechanisms such as tip masses or module self-mass, among others.

[0076] Large-scale space-based solar power stations according to many embodiments of the invention utilize a distributed approach to capture solar radiation, and to use the energy thus captured to operate power transmitters, which transmit power to one or more remote receivers (e.g., using laser or microwave emissions). The satellite modules of the solar power station can be physically independent structures, each comprising an independent array of power generation tiles. The satellite modules are each placed into a specified flying formation within an array of such satellite modules in a suitable orbit about the Earth. The position of each of the independent satellite modules in space within the orbital array formation can be controllable via a combination of station-keeping thrusters and/or controlled forces from absorption, reflection, and emission of electromagnetic radiation, as well as guidance controls. Using such controllers each of the independent satellite modules may be positioned and maintained within the controlled orbital array formation relative to each of the other satellite modules so that each satellite module forms an independent modular element of the large-scale space-based solar power station. The solar radiation received by each of the power generation tiles of each of the independent satellite modules is utilized to generate electricity, which powers one or more power transmitters on each of the power generation tiles. Collec-

tively, the power transmitters on each of the power generation tiles can be configured as independent elements of an antenna array.

[0077] The power generation tiles and/or satellite modules may also include separate electronics to process and exchange timing and control information with other power generation tiles and/or satellite modules within the large-scale space-based solar power station. In many implementations, the separate electronics form part of an integrated circuit that possesses the ability to independently determine a phase offset to apply to a reference signal based upon the position of an individual tile and/or transmitter element. In this way, coordination of a phased array of antennas can be achieved in a distributed manner.

[0078] In embodiments of the distributive approach, different array elements of the phased array may be directed to transmit power with different transmission characteristics (e.g., phase) to one or more different remote power receiving collectors (e.g., ground based rectenna). Each satellite module of power generation tiles, or combinations of power generating tiles across one or more satellite modules, may thus be controlled to transmit energy to a different power receiving collector using the independent control circuitry and associated power transmitters.

[0079] A sun sensor refers to any sensor that may generate a signal based upon the intensity of solar illumination placed upon it. Sun sensors may be individual sensors or a grouping of sensors arranged in a package that generate a signal. Based on these signals, a determination may be made of the sun sensor's relative angle with respect to the sun. Shape estimation of a structure in space can be calculated in a number of ways. One method is evaluating the relative angles of sun sensors attached to a space structure against prior known or expected signals. Unexpected and/or unmonitored changes in the shape of a space structure containing a phased array of RF signals may negatively impact the efficiency of the phased array system. Based upon the calculated shape of a space structure from signal received from a sun sensor, further calculations can be produced to offset the phase of certain antennas in the phase to minimize any negative effect. Based upon these calculations, signals can be produced that are then transmitted to the individual antennas in the phase array to account for any changes made to the shape of the satellite module.

[0080] A photovoltaic cell (PV) refers to an individual solar power collecting element on a power generation tile in a satellite module. The PV includes any electrical device that converts the energy of light directly into electricity by the photovoltaic effect including elements made from polysilicon and monocrystalline silicon, thin film solar cells that include amorphous silicon, CdTe and CIGS cells, multijunction cells, perovskite cells, organic/polymer cells, and various alternatives thereof.

[0081] A power transmitter or radiator refers to an individual radiative element on a power generation tile in a satellite module and its associated control circuitry. A power transmitter can include any device capable of converting power in the electrical current generated by the PV to a wireless signal, such as microwave radiation or light, including (but not limited to) a laser, a klystron, a traveling-wave tube, a gyrotron, or suitable transistor and/or diode. A power transmitter may also include suitable transmissive antennas, such as, dipole, patch, helical or spherical antennas, among others.

[0082] An array of antennas refers to an array of power transmitters in which the relative phases and/or amplitudes of the respective signals feeding the power transmitters are configured such that the effective radiation pattern of the power emission of the array is reinforced in a desired emission direction and suppressed in undesired directions. Arrays of antennas in accordance with embodiments may be dynamic or fixed, active or passive.

[0083] An orbital array formation refers to any size, number or configuration of independent satellite modules being flown in formation at a desired orbit in space such that the position of the satellite modules relative to each other is known such that power generation tiles on each of the satellite modules within the formation serves as an array element in the antenna array of the solar power station.

[0084] A power generation tile refers to an individual solar power collecting and transmitting element in the phased array of the large-scale space-based solar power station. In many embodiments a power generation tile is a modular solar radiation collector, converter and transmitter that collects solar radiation through at least one photovoltaic cell disposed on the tile, and uses the electrical current to provide power to at least one power transmitter collocated on the same tile that transmits the converted power to one or more remote power receiving collectors. Many of the power generation tiles incorporated within a space-based solar power station include separate control electronics that independently control the operation of the at least one power transmitter located on the power generation tile based upon timing, position, and/or control information that may be received from other tiles and/or other satellite modules within the large-scale space-based solar power station. In this way, the separate control electronics can coordinate (in a distributed manner) the transmission characteristics of each of the power generation tiles to form a phased array. Each power generation tile may also include other structures such as radiation collectors for focusing solar radiation on the photovoltaic, thermal radiators for regulating the temperature of the power generation tile, and radiation shielding, among other structures.

[0085] A satellite module refers to an array of power generation tiles collocated on a single integral space structure. The space structure of the satellite module may be a compactable structure such that the area occupied by the structure may be expanded or contracted depending on the configuration assumed. The satellite modules may include two or more power generation tiles. Each power generation tile may include at least one solar radiation collector and power transmitter. As discussed above, each of the power generation tiles may transmit power and may be independently controlled to form an array element of one or more phased arrays formed across the individual satellite module or several such satellite modules collectively. Alternatively, each of the power generation tiles collocated on a satellite module may be controlled centrally.

[0086] A lightweight space structure refers to integral structures of movably interrelated elements used in the construction of the power generation tiles and/or satellite modules that may be configurable between at least packaged and deployed positions wherein the area and or dimensions of the power generation tiles and/or satellite modules may be reduced or enlarged in at least one direction. The lightweight space structures may incorporate or be used in conjunction

with deployment mechanisms providing a deploying force for urging the movable elements between deployed and compacted configurations.

[0087] A large-scale space-based solar power station or simply solar power station refers to a collection of satellite modules being flown in an orbital array formation designed to function as one or more phased arrays. In several embodiments, the one or more phased arrays may be operated to direct the collected solar radiation to one or more power receiving collectors.

[0088] Transmission characteristics of a power generation tile refer to any characteristics or parameters of the power transmitter of the power generation tile associated with transmitting the collected solar radiation to a power receiving collector via a far-field emission. The transmission characteristics may include, among others, the phase and operational timing of the power transmitter and the amount of power transmitted.

Structure of Large-Scale Space-Based Solar Power Station

[0089] A large-scale space-based solar power station including a plurality of satellite modules positioned in an orbital array formation in an orbit about the Earth in accordance with embodiments of the invention is illustrated in FIG. 1. The large-scale space-based solar power station **100** includes an array of independent satellite modules **102**. The solar power station **100** is configured by placing a plurality of independent satellite modules **102** into a suitable orbital trajectory in an orbital array formation **104**, according to one embodiment. The solar power station **100** may include a plurality of such satellite modules **1A** through **NM**. In one embodiment, the satellite modules **1A** through **NM** are arranged in a grid format as illustrated in FIG. 1. In other embodiments, the satellite modules are arranged in a non-grid format. For example, the satellite modules may be arranged in a circular pattern, zigzagged pattern or scattered pattern. Likewise, the orbit may be either geosynchronous **106**, which is typically at an altitude of 35,786 km above the Earth, or low Earth **108**, which is typically at an altitude of from 800 to 2000 km above the Earth, depending on the application of the solar power station. As can readily be appreciated, any orbit appropriate to the requirements of a specific application can be utilized by a space-based solar power station in accordance with various embodiments of the invention.

[0090] In many embodiments, the satellite modules in the solar power station are spatially separated from each other by a predetermined distance. By increasing the spatial separation, the maneuverability of the satellite modules in relation to each other is simplified. As discussed further below, the separation and relative orientation of the satellite modules can impact the ability of the power generation tile on each of the satellite modules to operate as elements within an antenna array. In one embodiment, each satellite module **1A** through **NM** may include its own station keeping and/or maneuvering propulsion system, guidance control, and related circuitry. Specifically, as illustrated in FIG. 2, each of the satellite modules **102** of the solar power station **100** may include positioning sensors to determine the relative position **110** of the particular satellite module **1A** through **NM** in relation to the other satellite modules **1A** through **NM**, and guidance control circuitry and propulsion system to maintain the satellite module in a desired position within the arbitrary formation **104** of satellite modules during

operation of the solar power station. Positioning sensors in accordance with many embodiments can include the use of external positioning data from global positions system (GPS) satellites or international ground station (IGS) network, as well as onboard devices such as inertial measurement units (e.g., gyroscopes and accelerometers), and combinations thereof. Sun sensors may also be utilized to determine position by creating signals based upon illumination received which is relative to the position of the sensor in relation to the sun. These sun sensors may also be utilized for estimating the relative positions of antennas within a satellite module by estimating the satellite's shape. In several embodiments, the positioning sensors can utilize beacons that transmit information from which relative position can be determined that are located on the satellite modules and/or additional support satellites. The guidance control and propulsion system may likewise include any suitable combination of circuitry and propulsion system capable of maintaining each of the satellite modules in formation in the solar power station array **104**. In many embodiments the propulsion system may utilize, among others, one or more of chemical rockets, such as biopropellant, solid-fuel, resistojet rockets, etc., electromagnetic thrusters, ion thrusters, electrothermal thrusters, solar sails, etc. Likewise, each of the satellite modules may also include attitude or orientational controls, such as, for example, reaction wheels or control moment gyroscopes, among others.

[0091] In many embodiments, as illustrated in FIG. 3, each satellite module **1A** through **NM** of the solar power station **100** comprises a space structure comprised of one or more interconnected structural elements **111** having one or more power generation tiles **112** collocated thereon. Specifically, each of the satellite modules **1A** through **NM** is associated with an array of power generation tiles **112** where each of the power generation tiles of the array each independently collect solar radiation and convert it to electric current. Power transmitters convert the electrical current to a wireless power transmission that can be received by a remote power receiving station. As discussed above, one or more power transmitters on each of a set of power generation tiles can be configured as an element in one or more phased arrays formed by collections of power generation tiles and satellite modules of the overall solar power station. In one embodiment, the power generation tiles in the satellite module are spatially separated from each other by a predetermined distance. In other embodiments, the construction of the satellite modules is such that the power generation tiles are separated by distances that can vary and the distributed coordination of the power generation tiles to form a phased array involves the control circuitry of individual power transmitters determining phase offsets based upon the relative positions of satellite modules and/or individual power generation tiles. In further embodiments, sun sensors are disposed on power generation tiles that generate signals that correlate to the power generation tile's shape and position relative to the sun which may be combined with other power generation tiles and then utilized to determine the shape of the satellite module and phase offset signals for the antennas in the array necessary to minimize phase errors generated due to deformations in the shape of the satellite module in space.

Power Generation Tiles

[0092] Power generation tiles **112** according to many embodiments include a multicomponent structure including

a photovoltaic cell **113**, a power transmitter **114**, and accompanying control electronics **115** electrically interconnected as required to suit the needs of the power transmission application. As illustrated in FIG. **4a**, in some embodiments photovoltaic cells **113**, may comprise a plurality of individual photovoltaic elements **116** of a desired solar collection area that may be interconnected together to produce a desired electrical current output across the power generation tile. Some power transmitters **114** include one or more transmission antennas, which may be of any suitable design, including, among others, dipole, helical and patch. In the illustrated embodiment, a conventional patch antenna **114** incorporating a conductive feed **117** to conductively interconnect the RF power from the control electronics **115** to the antenna **114**. As can readily be appreciated the specific antenna design utilized is largely dependent upon the requirements of a specific application. Some power transmitters **114** are physically separated from one or both of the photovoltaic cell **113** and/or the control electronics **115** such as by fixed or deployable spacer structures **118** disposed therebetween. Some control electronics **115** may include one or more integrated circuits **119** that may control some aspect of the power conversion (e.g., to a power emission such as collimated light or an radio frequency (RF) emission such as microwave radiation), movement and/or orientation of the satellite module, inter- and intra-satellite module communications, and transmission characteristics of the power generation tile and/or satellite module. Further conductive interconnections **120** may connect the control electronics **115** to the source power of the photovoltaic cell **113**. Each of the power generation tiles may also include thermal radiators to control the operating temperature of each of the power generation tiles.

[0093] In some embodiments, the PV **113** is a multi-layer cell, as illustrated in FIG. **4b**, incorporating at least an absorber material **113'** having one or more junctions **113''** disposed between a back contact **121** on a back side of the absorber material and a top radiation shield **122** disposed on the surface of the absorber material in the direction of the incident solar radiation. The PV may include any electrical device that converts the energy of light directly into electricity by the photovoltaic effect including elements made from polysilicon and monocrystalline silicon, thin film solar cells that include amorphous silicon, CdTe and CIGS cells, multijunction cells, perovskite cells, organic/polymer cells, and various alternatives thereof. In some embodiments, the PVs are made from a thin film of GaInP/GaAs that is matched to the solar spectrum. Radiation shielding may include a solar radiation transparent material such as SiO₂, among others. The back contact may be made of any suitable conductive material such as a conductive material like aluminum, among others. The thickness of the back contact and top radiation shield may be of any thickness suitable to provide radiation shielding to the PV. Additional structures may be provided around the PV to increase the efficiency of the absorption and operation of the device including, for example, one or more concentrators that gather and focus incoming solar radiation on the PV, such as a Cassegrain, parabolic, nonparabolic, hyperbolic geometries or combinations thereof. The PV may also incorporate a temperature management device, such as a radiative heat sink. In some embodiments the temperature management device is integrated with the control electronics.

[0094] In a number of embodiments, the power transmitters that are components of power generation tiles are implemented using a combination of control circuitry and one or more antennas. The control circuitry can provide the power generation tile with the computational capacity to determine the location of the power generation tile antenna(s) relative to other antennas within the satellite module and/or the solar power station. As can readily be appreciated, the relative phase of each element within a phased array is determined based upon the location of the element and a desired beam direction and/or focal point location. The control circuitry on each power generation tile can determine an appropriate phased offset to apply to a reference signal using a determined location of the power generation tile antenna(s) and beam-steering information. Processes for determining the location of individual tile antennas and for determining phase offsets to apply based upon location in accordance with various embodiments of the invention are discussed further below.

[0095] In various embodiments, as illustrated conceptually in FIG. **4c**, power generation tile control circuitry can be implemented using one or more integrated circuits. An integrated circuit **123** can include an input/output interface **124** via which a digital signal processing block **125** can send and receive information to communicate with other elements of a satellite module, which typically includes a processor and/or memory configured by a control application. In certain embodiments, the digital signal processing block **125** receives location information (see discussion above) that can be utilized to determine the location of one or more antennas. In many embodiments, the location information can include a fixed location and/or one or more relative locations with respect to a reference point. The digital signal processing block can utilize the received location information and/or additional information obtained from any of a variety of sensors including (but not limited to) temperature sensors, accelerometers, ranging radars, and/or gyroscopes to determine the position of one or more antennas and calculate temperature dependent delays. Based upon the determined positions of the one or more antennas, the digital signal processing block **125** can determine a phase offset to apply to a reference signal **126** used to generate the RF signal fed to a specific antenna. In the illustrated embodiment, the integrated circuit **123** receives a reference signal **126**, which is provided to an RF synthesizer **127** to generate an RF signal having a desired frequency. The RF signal generated by the RF synthesizer **127** is provided to one or more phase offset devices **128**, which are configured to controllably phase shift and/or amplitude modulate the RF signal received from the RF synthesizer. Circuits that can be utilized to implement RF synthesizers and to controllably phase shift and/or amplitude modulate the RF signal received from the RF synthesizer include the various circuits disclosed in U.S. patent application Ser. No. 14/552,414 entitled "Generator Unit for Wireless Power Transfer", filed Nov. 24, 2014, the relevant disclosure from which is hereby incorporated by reference in its entirety.

[0096] The digital signal processing block **125** can generate control signals that are provided to the phase offset device(s) **128** to introduce the appropriate phase shifts based upon the determined location(s) of the one or more antennas. In several embodiments, such phase offset signals are generated by estimating the shape of the satellite module and the relative positions of the antennas in each of the power

generation tiles based upon sun sensors that are disposed on at least one of the power generation tiles. In many embodiments, the amplitude of the generated signal can be modulated and/or varied alone or in conjunction with the phase appropriately upon the determined locations to form the power beam and/or focused transmission. The amplitude can be modulated in a variety of ways such as at the input of a power amplifier chain via a mixer or within an amplifier via its supply voltage, an internal gate or cascade biasing voltage. As can readily be appreciated, any of a variety of techniques appropriate to the requirements of a specific application can be utilized to amplitude modulate an RF signal in accordance with various embodiments of the invention. The phase shifted RF signals can then be provided to a series of amplifiers that includes a power amplifier 129. While the entire circuit is powered by the electric current generated by the PV component(s) of the power generation tile, the power amplifier is primarily responsible for converting the DC electric current into RF power that is transmitted via the RF signal. Accordingly, the power amplifier increases the amplitude of the received phase shifted RF signal and the amplified and phase shifted RF signal is provided to an output RF feed 130 connected to an antenna. In many embodiments, the RF signal generated by the RF synthesizer is provided to an amplifier 131 and distributed to the control circuitry of other tiles. The distribution of reference signals between tiles in a module in accordance with various embodiments of the invention is discussed further below.

[0097] The interconnection of components in a power generation tile and the pathways via which the power generation tile exchanges information with other elements of a space-based power station constructed in accordance with various embodiments of the invention is conceptually illustrated in the power generation tile wiring diagrams shown in FIGS. 4d and 4e. In the illustrated embodiment, the power generation tile wiring 150 includes at least two layers of wiring. The layers of wiring can be implemented using any of a variety of printed circuit board technologies suitable for use with high frequency signals and/or space applications such as (but not limited to) polyamide and/or KAPTON®, which is a registered Trademark of E. I. DuPont de Nemours and Company of Wilmington, Del. Below a first or “bottom” layer (FIG. 4d) is the PV (connecting the supply connection locally to PV ground and PV supply). Above a second or “top” layer (FIG. 4e) is the patch antenna layer. REFIn/CLKin 151 is the reference/clock signal that can originate from a master tile (see discussion below). REFout/CLKout 152 are the buffered reference/clock signals generated from the input clock to be connected to REFIn/CLKin signals of another power generation tile. The same connection logic applies to Din/Dout (data in, data out) pairs 153 for master-to-slave data connections. The connection direction is reversed for Din/Dout (Slave-to-master). It should be further noted that Din/Dout lines 153 can denote a general address and data bus of lines. While depicted as a single line, multiple lines can be run in parallel to enhance data throughput through the communication channel. As can readily be appreciated, via connections 154 can be utilized to connect the traces and supplies to the IC, for example to solder pads of a so-called flip-chip mounted IC.

[0098] The lines on the first or “bottom” layer (but not the supply connections) are assumed to be continuous between tiles (as the tiles are physically connected). If the tiles (or

panels) are fabricated with interruptions, connectors including (but not limited to) a short ribbon cable type connection can be used for connection. The second or “top” layer (FIG. 4e) displays coplanar RF lines 155 connecting the RF output from an integrated circuit 156 similar to the integrated circuit described above and the RF antenna. The RF lines 155 can include (optionally) bypass capacitors 157. In operation, the RF bypass capacitors 157 can allow RF currents to flow, enabling the PV supply and PV ground metallization to act as a continuous ground shield for the patch antenna at RF frequencies of interest. Four connections 158 are shown here for differential RF signals for two polarizations. As can readily be appreciated, any of a variety of feeds appropriate to the specific antenna(s) utilized by a power generation tile can be utilized. The connection can be made with a ribbon connection and the impedance of the connection is taken into account to provide an overall “impedance match”.

[0099] Although specific wiring implementations for power generation tiles are described above with reference to FIGS. 4d and 4e, any of a variety of wiring implementations can be utilized as appropriate to the requirements of specific applications in accordance with embodiments of the invention including (but not limited to) utilizing more than two layers of PCB material and metallization can be used to facilitate routing or provide increased flexibility. In addition, connection lines for RF or high-speed signals can utilize any one of the many well-known techniques for routing RF or high-speed AC signals such as, but not limited to, microstrip transmission lines, coplanar transmission lines, striplines. For high speed digital signals, frequently interconnections employing nearby ground reference routing are employed to increase the through-put of the interconnection.

[0100] Furthermore, although specific integrated circuit and power generation tile implementations are described above with reference to FIGS. 4a-4e, power generation tiles and power generation tile control circuitry can be implemented using any of a variety of techniques including (but not limited to) different types of integrated circuits and computing platforms in accordance with various embodiments. Furthermore, satellite modules can be implemented without providing computational capabilities on each power generation tile and/or without utilizing the computational capabilities of a power generation tile to determine locations and/or phase shifts for the purposes of generating an RF signal to feed a power generation tile antenna. Indeed, in several embodiments, power generation tiles within a satellite module (or between modules) may be different. The number of distinct combinations of photovoltaic cells, transmission modules and control electronics may be as large as the number of power generation tiles in the satellite modules. Further, even where each of the power generation tiles on a satellite module are the same, each of the satellite modules 1A through NM or a group of satellite modules may have different solar radiation collection or transmission characteristics and/or may have arrays of power generation tiles of different sizes, shapes and configurations. As can readily be appreciated, the design and function of individual tiles utilized within a space-based solar power station is only limited by the requirements of specific applications. The use of power generation tiles to wirelessly transmit power from a space-based solar power station in accordance with various embodiments of the invention is discussed further below.

Power Transmission Using Steerable Beams

[0101] In many embodiments, as illustrated conceptually in FIGS. 5a-5c, a plurality of power generation tiles 112 on each satellite module may each form a panel 160 in which the antenna elements of the power generation tiles form part of an array 162 that can be utilized for wireless power transmission. In several embodiments, the amplitude and/or phase of RF signals transmitted by the antennas in the array 162 are controllable to provide a steerable beam of power.

[0102] In a number of embodiments, coordination of the power generation tiles 112 to form an array 162 for the transmission of wireless power involves distribution of a reference signal to the power generation tiles. As noted above, control circuitry on power generation tiles 112 can shift the phase and/or modulate the amplitude of the reference signal. Therefore, reference signals may be generated locally on each power generation tile or satellite module and propagated via wired or wireless intra and inter-module communication links, or may be generated centrally from a single source on a single satellite module and propagated via wired or wireless intra and/or inter-module communication links across each of the satellite modules and power generation tiles. In addition, one or multiple reference signals may be generated from outside the space-based solar power station system such as one or more satellites flying in close proximity or even in different orbits; as well as from one or more ground stations.

[0103] The phase offset and/or amplitude modulation applied to the reference signal by the control circuitry at an individual power generation tile to achieve a steerable beam is dependent upon the position of the power generation tile 112 relative to other power generation tiles within the array 162. Accordingly, the efficiency of wireless power transmissions generated by an array 162 can be significantly increased by precisely determining the location of the power generation tiles 112 within the array and modifying phase offsets and/or amplitude modulations accordingly. In many embodiments, the positional information of each tile is received from partially redundant systems, such as, but not limited to, gyroscopes, accelerometers, electronic ranging radar, electronic positioning systems, phase and/or timing information from beacons, as well as employing a priori knowledge from system steering and flight control commands. In several embodiments, electronic systems are located on the ground, and/or in space on satellites deployed for this purpose (and, possibly, other purposes, e.g. in the case of using GPS satellites). The generation and distribution of reference signals and the determination of the locations of power generation tiles within a spaced-based solar power station in accordance with various embodiments of the invention is discussed further below.

Distribution of Reference Signals within a Space-Based Solar Power Station

[0104] The process of distributing a reference signal between the sub-arrays formed by each of the satellite modules in a space-based solar power station in accordance with an embodiment of the invention is conceptually illustrated in FIG. 5d. A reference signal 170 is distributed 172 to each of the satellite modules 102 within the space-based solar power station. When a space-based solar power station is implemented using a plurality of independently orbiting satellite modules in the manner illustrated in FIG. 1, wired connections between the satellite modules of a space-based solar power station are not feasible. As is conceptually

illustrated in FIG. 5e, movement and/or rotation of individual satellite modules 102 makes wired connections between the satellite modules difficult to implement. Furthermore, local wireless connections between the satellite modules can also be problematic due to the potential for continuous changes in the relative orientation of the satellite modules 102. Accordingly, reference signals can be distributed to the satellite modules of a space-based solar power station by a transmitter. The transmission of a reference signal to satellite modules 102 within a space-based solar power station by a transmitter 180 in accordance with an embodiment of the invention is conceptually illustrated in FIG. 5f. The wireless signal can then be propagated to the tiles on the panels of a satellite module using wired and/or wireless connections. In other embodiments, each panel within a satellite module can wirelessly receive the reference signal and/or individual power generation tiles within panels can wirelessly receive the reference signal.

[0105] Transmitters used to provide reference signals to space-based solar power stations in accordance with various embodiments of the invention can be located in space and/or on Earth. The transmissions can be implemented using communication technologies including (but not limited to) transmitters and receivers that establish RF and/or optical communication channels.

[0106] In many embodiments, the received power of a transmitted reference signal is relatively weak compared to the signal strength of the reference signal distributed within a satellite module, and/or panel of the space-based solar power station. In a number of embodiments, satellite modules that receive the transmitted reference signal utilize a low bandwidth clean-up phase locked loop (PLL) to lower the noise component of the incoming reference signal. A satellite module 102 including an antenna 190 to receive a transmitted reference signal, a low noise amplifier 192 to increase the amplitude of the received reference signal, and a clean-up PLL 192 to generate a low noise reference signal that is output to the power generation tiles within the satellite module in accordance with an embodiment of the invention is conceptually illustrated in FIG. 5g.

[0107] An implementation of a clean-up PLL incorporating a low-noise voltage controlled oscillator in accordance with an embodiment of the invention is conceptually illustrated in FIG. 5h. The clean-up PLL 200 includes a phase-frequency detector (PFD) 202 that outputs a digital pulse with a width proportional to a sampled phase error. The digital pulse is provided to a control circuit 204 that generates a control voltage provided to a voltage controlled oscillator (VCO) 206. A feedback loop 208 enables the PFD to perform a phase comparison between the output generated by the VCO 206 and the received reference signal. As noted above, the clean-up PLL band limits the noise from the received reference signal and the remaining VCO noise should be lower than the reference noise as conceptually illustrated in FIG. 5i. Although specific circuits for receiving transmitted reference signals are described above with reference to FIGS. 5g-5i, any of a variety of receivers can be utilized to receive a reference signal at a spaced-based solar power station for the purposes of coordinating the operation of power generation tiles as an antenna array as appropriate to the requirements of specific applications in accordance with embodiments of the invention.

[0108] Ideally, noise in the received reference signal correlates among all receivers within a space-based solar power

station in accordance with embodiments of the invention. In practice, however, differences in the receiver electronics (e.g. slightly different loop bandwidths of clean-up PLLs) in different receivers will de-correlate noise. In addition, different receivers will receive different background noise. Receive antennas can receive noise from the Earth, the Sun, and cosmic background. In embodiments that utilize a space-based reference transmitter (e.g. a transmitter located on a satellite orbiting with the space-based solar power station), the dominant noise sources include the Earth (angle dependent) and cosmic background radiation. Accordingly, the receive antenna can have high gain resulting in better signal-to-noise ratio of the received reference signal, assuming that the relative position of the reference transmitter and receiver on the module or tile does not vary appreciably. When an Earth-based reference transmitter is utilized, dominant sources of noise include noise from the Earth, the Sun, and cosmic background radiation. Accordingly, the receive antenna will have low gain. The transmitter power required to obtain a desired reference signal strength at a space-based solar power station can be determined using Friis' equation, which is as follows:

$$\frac{P_{received}}{P_{transmitted}} = \left(\frac{\lambda}{4\pi R}\right)^2 G_t G_r$$

[0109] Minimum transmitter power required when utilizing a space-based reference transmitter in accordance with various embodiments of the invention is illustrated in FIG. 5j. Below 1 GHz, background noise power grows somewhat faster than the square of the wavelength of the transmitter reference signal. Friis' equation also suggests a shrinking absolute receive antenna size in a manner that is inversely proportional to the square of the wavelength of the transmitted signal. When utilizing a space-based reference transmitter, it is worthwhile noting that centrally locating the transmitter relative to the satellite modules of the space-based solar power station can create a system that is sensitive to movement of the satellite modules relative to the transmitter. Accordingly, locating the transmitter a distance that is sufficiently large that relative movement of the transmitter and the satellite modules of the space-based solar power station impacts each of the receivers on the space-based solar power station approximately equally can be desirable.

[0110] Transmitting a reference signal from Earth can be comparatively more robust to the relative motion of the satellite modules of a space-based solar power station. However, the transmitted signal can be more prone to jamming and interference. Required gain and aperture size for a receiver that receives a reference signal transmitted by an Earth-based transmitter in accordance with various embodiments of the invention is illustrated in FIG. 5k.

[0111] Once a reference signal is received at a space-based solar power station, distribution of the reference signal between control circuits of power generation tiles can result in increased jitter in the reference signal with increased redistribution of the reference signal. The redistribution of a reference signal typically involves the buffering and retransmission of the reference signal, which increases jitter. The cascading of jitter in this manner is conceptually illustrated in FIG. 5l. A common reference signal 210 is provided to control circuitry that introduces jitter 212 in the synthesis of

an RF signal transmitted by a transmitter 214. The jitter introduced by the control circuitry is compounded in each cascaded redistribution of the common reference signal. Efficiency can be shown to degrade proportionally to the root of the sum of the squared jitter contributions. Simulations of the effect of jitter on the efficiency of power transmission by a 75 m×60 m space-based solar array at 1 GHz based upon the size of the rectenna array receiver are illustrated in FIG. 5m. In many embodiments, the received reference signal can be routed to the power generation tiles within a satellite module in such a way as to reduce and/or minimize the average number of stages of reference signal distribution prior to the reference signal being received by the control circuitry of a power generation tile. In several embodiments, the received reference signal is routed in a manner conceptually illustrated in FIG. 5n in which the reference signal is provided by a power generation tile to its immediately adjacent power generation tiles (i.e. power generation tiles that are adjacent, but not diagonally adjacent) that do not already receive the reference signal from another power generation tile.

[0112] Although specific techniques for distributing a reference signal between control circuitry of power generation tiles within a panel and/or satellite module of a space-based solar power station are described above with reference to FIGS. 5l-5n, any of a variety of techniques can be utilized to distribute a common reference to control circuitry of power generation tiles including (but not limited to) separately transmitting the common reference to each power generation tile, wirelessly transmitting the common reference signal to power generation tiles within the satellite module, and/or utilizing different routings to reduce the average number of redistributions of the common reference as appropriate to the requirements of specific applications in accordance with embodiments of the invention. As discussed above, the phase shifts and/or amplitude modulations applied to the reference signal by the control circuitry of a specific power generation tile typically depends upon the location of the power generation tile relative to other power generation tiles in the array. Processes for determining the locations of power generation tiles within a space-based solar power station for the purposes of modifying the phase and/or amplitude of a reference signal received by the power generation tiles in accordance with various embodiments of the invention are discussed further below.

Processes for Determining Location of Elements in a Space-Based Solar Power Station

[0113] The phase shift and/or amplitude modulation applied to a reference signal by the control circuitry of a specific power generation tile may depend upon both the path length travelled by the reference signal to reach the control circuitry and the relative position of the antenna of the power generation tile relative to the other antennas within the antenna array. In a conventional phased array, antennas within the array are fixed statically relative to each other and can be calibrated accordingly. The freedom of movement of satellite modules, panels, and/or power generation tiles within a space-based solar power station in accordance with various embodiments of the invention increases the complexity of determining the phase shift to be applied in order to coordinate the activity of the array of antennas to create a steerable beam of transmitted power. Shifts in the relative positions of the satellite modules, panels, and/or power

generation tiles can alter the distance travelled by a reference signal to reach a specific power generation tile. In addition, the shifts can change the baseline and orientation of the antenna of a specific power generation tile relative to the antennas of other power generation tiles within the array. In a number of embodiments, the location of the antennas of the power generation tiles is determined and the locations utilized to determine a phase shift and/or an amplitude modulation to apply to a reference signal received by the power generation tiles.

[0114] Various approaches can be taken with respect to the determination of location including approaches that involve centralized computation, a hierarchy of computations and/or distributed computations to determine location. As noted above, location information can include a fixed location and/or one or more relative locations with respect to a reference point. Locations can be specified with respect to both displacement and rotation. In many embodiments, location can be determined using partially redundant systems, such as, but not limited to, gyroscopes, accelerometers, electronic ranging radar, electronic positioning systems, phase and/or timing information from beacons, as well as employing a priori knowledge from system steering and flight control commands. In several embodiments, electronic systems are located on the ground, and/or in space on satellites deployed for this purpose (and, possibly, other purposes, e.g. in the case of using GPS satellites).

[0115] Determination of location using a signal or signals transmitted by an Earth-based transmitter or transmitters in accordance with an embodiment of the invention is conceptually illustrated in FIG. 5o. In the illustrated embodiment, the terrestrial transmitter **220** transmits a ranging signal to a space-based solar power station **100** and the space-based solar power station **100** utilizes a hierarchical approach to determine the locations of the antennas of the power generation tiles **112** in each of its satellite modules **102**. As is illustrated in FIG. 5p, the process **230** of distributing location information in a hierarchical fashion between satellite modules, panels and/or tiles within the space-based solar power station, such that a central processing unit determines (**232**) location based upon the received signal and relays a determined location, which can include (but is not limited to) the location and orientation of the entire space-based solar power station with respect to a ground station and/or other suitable known locations to satellite modules within the system. The relayed information can be expressed as an absolute and/or differential location(s), and/or orientation(s) as appropriate to the requirements of specific applications. In a similar fashion, the location and/or orientation of each satellite module with respect to the center of the space-based solar power station or other suitable reference point can be determined (**234**) at each satellite module using processes similar to those outlined above. Furthermore, going down a hierarchical level, the position and orientation information of individual panels and tiles can be determined (**234**) in a similar fashion by the control circuitry of individual power generation tiles. The entirety or any useful part of this information can be used at the tile-level, the panel-level, the module-level, the system-level and/or any combination thereof to control the phase and/or amplitude of the RF signal provided to the antennas of each power generation tile to form a beam or focal spot on the ground. The aggregate computational power of the computational resources of each tile, panel and/or satellite module can be utilized since each

tile (and/or panel or satellite module) can utilize its local computational power available from a DSP, microcontroller or other suitable computational resource to control its operation such that the system in aggregate generates the desired or close-to desired beam and/or focused transmission.

[0116] Although specific hierarchical approaches and hierarchical processes for determining location information are described above with respect to FIGS. 5o and 5p, any of a variety of approaches can be utilized to determine location as appropriate to the requirements of specific applications in accordance with embodiments of the invention including (but not limited to) approaches that rely upon spaced-based transmission to determine position and/or orientation and/or approaches that utilize a variety of sources of information to determine position and/or orientation.

[0117] As noted above, the precision with which location of various elements within a space-based solar power station is determined can be a factor that contributes to the phase error. Structures that are large and light can deform and vibrate easily. These deformation and variations in the shape of the space structure can introduce additional changes in the positions of the antennas which may directly increase phase error. The impact of the RMS phase error in an antenna array on efficiency is illustrated in FIG. 5q. Accordingly, specific techniques may be utilized to determine the shape of the space-based solar power array system as it undergoes deformations in space. Methods of using sun sensors to determine the shape of the structure to reduce phase error in accordance with various embodiments of the invention are discussed below.

Shape Estimation Using Sun Sensors

[0118] As previously discussed, the knowledge of the relative positions of antennas in an array can be important to the application of phase shifts and/or amplitude modulation to a reference signal to coordinate the antennas as a phased array. In many embodiments, the shape of the satellite module can be determined using signals generated by sun sensors that are placed on the satellite module itself. In a number of embodiments, multiple sun sensors are disposed on power generation tiles, which are then connected to a microprocessor configured to determine the shape of each tile, the relative position of each tile in relation to each other, and the relative position of each antenna of the entire phase array. In a further embodiments, sun sensors may be placed on only a few power generation tiles as long as those tiles are part of a continuous structure. In still further embodiments, sun sensors may be placed on any part of the satellite structure that is continuous. In several embodiments, shape estimation can be determined using these sensors alone and without the necessity of an external electronics system located on the ground and/or in space. However, in many embodiments, such external electronics systems and/or additional sensor systems including, but not limited to, accelerometers and/or gyroscopes may add to the sun sensor's accuracy through the use of techniques to integrate data from multiple sources including, but not limited to, a Kalman filter.

[0119] A process for performing shape estimation using solar sensors in accordance with an embodiment of the invention is conceptually illustrated in FIG. 10. In many embodiments, the process **1000** may begin by receiving **1010** sensor signals from the sun sensors attached to the power generation tiles. In some embodiments, the data

received may then be formatted **1020** depending on the need of the application required. In a number of embodiments, the sensor data received from the available tiles may be integrated **1030**. In many further embodiments, the data may then be utilized to determine **1040** a shape of the structure on which the sun sensors are mounted. In even further embodiments, based upon the estimated shape of the structure, phase offsets and/or amplitudes to apply to specific RF signals transmitted by antennas within the antenna array can be determined **1050**. In many embodiments, the shape determination may be accomplished through a number of methods, including, but not limited to, the generation of a finite element model of the structure, utilizing a Kalman filter, or other state estimation techniques including (but not limited to) particle filters and/or Markov Random Fields.

[0120] Various methods may be utilized with respect to the determination of shape including approaches that involve centralized computation, a hierarchy of computations and/or distributed computations to determine shape. In some embodiments, a finite element model is utilized to determine the shape of the structure. A power generation tile including sun sensors placed on the body of the tile in accordance with an embodiment of the invention is conceptually illustrated in FIG. **11a**. A finite element model processes a more complex piece of geometry into simpler component parts or subdomains. These smaller subdomains can then be systematically recombined into a global system to represent a final calculation on the full system. A finite element model of FIG. **11a** is conceptually illustrated in FIG. **11b** in accordance with an embodiment of the invention. The smaller squares represent subdomains that may be utilized in aggregate to represent the shape of the power generation tile of FIG. **11a**. A power generation tile that is undergoing shape deformation is conceptually illustrated in FIG. **11c**. Such a deformation will naturally change the shape of the tile, and possibly other surrounding tiles or structures. In many embodiments of the invention, the sun sensors measure the relative angle of the sensor from the sun. In many embodiments, sensor outputs can change in response to deformation due to the displacement of a spot created by an aperture plate onto a photodiode array resulting from the relative angle of the sun to the sun sensor. In a number of embodiments, when the sensor rotates, the spot created by the aperture plate moves and the relative illumination of each of the sun sensors varies, allowing for an integration to determine the angles from the light source to the center of the aperture hole. An example of these deformations being used to generate a finite element model is conceptually illustrated in FIG. **11d** in accordance with an embodiment of the invention. The sensors provide data to the system which may allow for an estimated shape of the structure to be determined. In many embodiments, alternative sensors or algorithms may be utilized to mimic or improve such estimated shapes including, but not limited to, accelerometers, gyroscopes, and/or triangulation methods based upon received signals including, but not limited to, signals received from Global Positioning System satellites.

[0121] Sun sensors can be configured in a number of ways to detect the relative angle of the sensor with respect to the sun. A sun sensor in accordance with an embodiment of the invention is conceptually illustrated in Figure **11e**. In a number of embodiments, the sun sensor **1100** contains an array of photodiodes **1120** on the bottom of the sensor. In many embodiments, these photodiodes **1120** are enclosed in the structure of the sun sensor **1100**. In further embodiments,

the top of the sun sensor **1100** contains an aperture plate **1110**. In even further embodiments, the aperture plate **1100** allows light to enter into the sun sensor **1100** and strike the photodiodes **1120** at the bottom of the sun sensor **1100**. In still further embodiments, changes in the intensity of sun light on each of the photodiodes in the array may be integrated to determine the angles from the light source to the center of the aperture hole. These determinations of relative angles can then be used to determine the overall shape of the structure. In several embodiments, signals output by the photodiodes are digitized by circuitry such as (but not limited to) a microcontroller, FPGA, or ASIC collocated with the sun sensor. In many embodiments, sensor outputs from multiple sun sensors are digitized by a common circuit. In other embodiments, the sun sensors are implemented using cameras incorporating charge coupled device (CCD) sensors or complementary metal-oxide-semiconductor (CMOS) image sensors. As can readily be appreciated, the specific manner in which the sun sensor is implemented is largely dependent upon the requirements of a specific application in accordance with various embodiments of the invention.

[0122] In many embodiments, Kalman filters may be utilized to aide the shape estimation process. Kalman filters are employed in many stochastic systems in order to improve the reliability of state estimations. Kalman filters utilize recursive processing to achieve the improved results. The recursive nature of the Kalman filter can enable the use of only a limited data set, which can minimize storage and computational demands. Broadly, a Kalman filter analyzes the current state of the system along with the uncertainties about the input methods and then generates a weighting average to these inputs based on current observations. These results can then be used for the next event where the results are updated again. This method can be ideal for systems where there are uncertainties about the state or inputs and/or when signal noise is present. The structure of the Kalman filter also ensures that the more data that is used in the processing, the more accurate the results will be. Furthermore, virtually any type of sensor may be utilized as an input. As discussed above, shape information can include a fixed location and/or one or more relative locations with respect to a reference point. In a number of embodiments, the sun sensors are utilized for shape measurement. In many further embodiments, shape determination can be aided using partially redundant systems, such as, but not limited to, gyroscopes, accelerometers, electronic ranging radar, electronic positioning systems, phase and/or timing information from beacons, as well as employing a priori knowledge from system steering and flight control commands. Although specific methods for estimating shapes based on sensors in an array are described above with reference to FIGS. **10-11e**, any of a variety of processes can be utilized to estimate the shape of structures in an array. For example, in several embodiments, electronic systems are located on the ground, and/or in space on satellites deployed for this purpose (and, possibly, other purposes, e.g. in the case of using GPS satellites).

[0123] In many embodiments, performance of shape estimation processes may require additional equipment to be attached to the power generation tiles or satellite structure. A power generation tile with the necessary equipment to determine shape in accordance with an embodiment of the invention is conceptually illustrated in FIG. **12a**. In the

illustrated embodiment, the power generation tile **1200** has multiple sun sensors **1220** disposed around the tile **1200**. In a number of embodiments, the sun sensors may be disposed on the power generation tile **1200** but not necessarily at each antenna location. In many embodiments, the position and number of the sun sensors **1220** are optimized to lower the total error when performing shape estimation with respect to the shape of the structure including, but not limited to, arranging the sun sensors on the satellite structure itself or across tiles that are in a continuous body. In further embodiments, the sun sensors **1220** are connected with a microprocessor **1240** which is configured to receive the output signals transmitted by the sensors **1220**. In a number of embodiments, the microprocessor generates a model of the structure shape and utilizes the results to generate phase offsets and/or amplitude modifications to be applied to a reference signal by individual antennas. In certain embodiments, the results are transmitted to the power transmitter **1260** which may adjust the phase shift and/or amplitude modulation to the reference signal. In certain further embodiments, the results are formatted into a phase shift and/or amplitude modulation in the microprocessor **1240** and then transmitted to the power transmitter **1260** for application. However, in many embodiments, shape determination may occur in a distributed manner over an array of tiles. In a number of embodiments, the sensors, microprocessor and transmitter may be in communication across multiple tiles. In many applications, shape estimation is performed not just for the tiles themselves, but also the shape of the tiles relative to each other. Changes in the shape of the tiles and the relative positions of the antennas configured as a phased array can be compensated for by adjustments to the phase shifts and/or amplitude modulations applied to reference signal by individual power transmitter circuits. A power generation tile phase array connected to a microcontroller is conceptually illustrated in FIG. **12b** in accordance with an embodiment of the invention. In a number of embodiments, the phase array system **1280** includes multiple power generation tiles **1200** arranged in a pattern. In many embodiments, power generation tiles **1200** may be equipped with sensors **1220** placed at various points upon the tile **1200**. In some embodiments, each of these sensors **1220** is connected across the satellite structure to a microcontroller **1240**. In several embodiments, the microcontroller **1240** may then utilize a shape determination application to generate phase shifts and/or amplitude modulations based upon the solar sensitive sensor signals for transmission via connections power transmitters **1260** located on each of the power generation tiles **1200**. In a number of embodiments, the results of the shape estimation application are transmitted to the power transmitters **1260** and are then converted to the proper phase shift and/or amplitude modulation to a reference signal. Although specific methods for estimating shapes based upon signals generated by sensors in an array are described above with reference to FIGS. **12a**, and **12b**, any of a variety of arrangements can be utilized to estimate the shape of tiles within a satellite module and to determine the relative distance and/or orientation of antennas in an array as appropriate to the requirements of specific applications in accordance with various embodiments of the invention.

[0124] As noted above, in a number of embodiments, a microcontroller can be responsible for acquiring all of the necessary input signals, determining the shape of the struc-

ture, and providing signals to the power transmitters that facilitate adjustments in the phase shift and/or amplitude modulation. A microcontroller in accordance with various embodiments of the invention is conceptually illustrated in FIG. **13**. In many embodiments, the microcontroller system **1300** comprises a microcontroller **1310** connected to at least one sensor **1320**, but may be connected to many sensors **1330**. In additional embodiments, the at least one sensor **1320** may interface with the microcontroller **1310** via an input/output interface module **1340** which delivers the data over the system bus **1390** to a memory system **1350**. In several embodiments, the memory system **1350** contains a shape estimation application **1351** and optional Kalman filter parameters **1352** which may be utilized by the shape estimation application **1351** when a Kalman filter is utilized. In further embodiments, the shape estimation application **1351** configures the processor **1360** to determine the shape of the structure based on data received from the sensors **1320** and any relevant data stored in memory **1350** which may include any of the previously mentioned sources of input including, but not limited to, accelerometers, gyroscopes, and/or triangulation methods based upon received signals including, but not limited to, signals received from Global Positioning System satellites. In yet further embodiments, the shape results are delivered to at least one power transmitter **1370** connected to the microcontroller **1310** via the input/output interface **1340**, but could also be delivered to multiple transmitters **1380**. Although specific approaches and designs for a microcontroller configured to determine shape are described above with respect to FIG. **13**, any of a variety of approaches and devices can be utilized to determine shapes as appropriate to the requirements of specific applications in accordance with various embodiments of the invention including (but not limited to) static look-up tables, and virtualized environments.

[0125] As previously discussed above, the precision with which location of various elements within a space-based solar power station is determined can be a factor that contributes to the phase error. Accordingly, the specific techniques utilized to determine location in space-based solar power array systems will typically depend upon the efficiency requirements of a specific application. The hierarchical distribution of reference signals, location information, and command and control information in accordance with various embodiments of the invention is discussed further below.

Coordinating Communication Between Elements of a Space-Based Solar Power Station

[0126] A variety of processes are described above for distribution of reference signals and hierarchical calculation and distribution of location and shape information between satellite modules, panels and tiles within a space-based solar power station implemented in accordance with various embodiments of the invention. In a number of embodiments, space-based solar power stations include satellite modules, panels and/or tiles with specialized functions to assist in the receipt and coordination of the distribution of different types of information to other elements of the space-based solar power station.

[0127] A space-based solar power station that includes at least one master satellite module configured to coordinate the receipt and distribution of a reference signal, location information, and command and control information in

accordance with an embodiment of the invention is illustrated in FIG. 5r. The space-based solar power station 100 includes a master satellite module 240 that includes a first transceiver 242 configured to receive a reference signal from an Earth-based transmitter 244. The master satellite module 240 also includes a second transceiver 246 configured to receive at least one ranging signal that can be utilized to determine the location of the space-based solar power station from at least one Earth-based transmitter 248. Although Earth-based transmitters are shown, space based transmitters and/or a combination of Earth-based and space-based transmitters can be utilized as appropriate to the requirements of specific applications in accordance with embodiments of the invention.

[0128] In the illustrated embodiment, the master satellite module 240 includes an additional transmitter 250 configured to wirelessly transmit the reference signal to other satellite modules 102 within the space-based solar power station. Data can also be wirelessly transmitted between the satellite modules using at least one transceiver located on each satellite module. In the illustrated embodiments, a first transceiver 252 is utilized to wirelessly transmit location information describing the location of the space-based solar power station to other satellite modules. As noted above, the location information can be absolute location and/or relative location information. In many embodiments, the location of the space-based solar power station is expressed as a position and an orientation. The master satellite module 240 also includes a second transceiver 254 that is utilized as a separate channel via which command and control information can be communicated. As can readily be appreciated, both location and command and control information may alternatively be transmitted on the same communication links. Alternatively the first transceiver can be implemented as a beacon that can be utilized by receivers on other satellite modules to determine position relative to the master satellite module. When the first transceiver is a beacon, the second transceiver can communicate location information describing the location of the space-based satellite array and/or the master satellite module to the other satellite modules.

[0129] When a satellite module 102 is equipped with appropriate receiver technology, the satellite module can receive the reference signal, location information, and/or command and control information transmitted by the master satellite module. In addition, various satellite modules 102 can provide data to the master satellite module including (but not limited to) location information describing the location of a specific satellite module, and command and control data. In the illustrated embodiment, the satellite modules 102 include a receiver 260 for receiving a reference signal. As noted above, the satellite module 102 can distribute the received wireless reference signal via wired connections to different power generation tiles within satellite module. The satellite modules 102 can also include a first transceiver 262 for exchanging location information with other satellite modules including (but not limited to) master satellite module(s) and a second transceiver 264 for exchanging command and control information with other satellite modules. As noted above, space-based solar power stations can use a single transceiver to exchange both location information, and command and control data with other satellite modules.

[0130] The use of different classes of power generation tiles to coordinate distribution of reference signals, location

information, and/or command and control information within a satellite module in accordance with an embodiment of the invention is illustrated in FIG. 5s. A satellite module 102 can include a master tile 270 that includes the receiver 260 for receiving a reference signal, the first transceiver 262 for exchanging location information with other satellite modules and the second transceiver 264 for exchanging command and control information with other satellite modules. Using the transceivers, the master power generation tile 270 can obtain a reference signal wirelessly transmitted from another satellite module and distribute the reference signal to other power generation tiles 272 within the satellite module. In many embodiments, the received reference signal is amplified and noise removed using a circuitry such as (but not limited to) the clean-up PLL described above. In addition, the master tile 270 can act as a hub for the exchange of location information, and command and control information within the satellite module. As can readily be appreciated, the various receiver and transceivers incorporated within the master power generation tile 270 can be distributed across multiple tiles within a satellite module. Furthermore, additional specialized tiles that may or may not perform power generation functions can be incorporated within a satellite module in accordance with various embodiments of the invention including (but not limited to) ranging tiles 276 that include a receiver or transceiver 262 capable of receiving location information and/or at least one ranging signal from which additional location information can be determined. Distributing the capability of determining location across multiple tiles within a satellite module can enable a more precise determination of the location of the satellite module and/or individual power generation tiles within the satellite module. Other functions that specialized tiles within a satellite module could accomplish are communication with a specialized system module (or separate control satellite) that coordinates operation over all satellite modules as well as communicating with the panels and tiles in the particular module. A specialized tile can also provide ranging or beacon functionality to allow tracking the satellite module position and orientation with respect to one or more reference locations such as co-orbiting satellites. Furthermore, a satellite module may contain more than one of these specialized tiles to facilitate measurement of the orientation and location of the satellite module as a whole and all of its tiles therein. The specialized tile or tiles may be of somewhat different dimension as the numerous power generation tiles to provide the necessary footprint for receive and transmit antennas since different frequencies requiring different footprints may be employed to facilitate communication. If the specialized tiles are sufficiently sparsely located within a module, these specialized tiles will result in negligible loss in microwave beam fidelity and minimal overhead. The specialized tiles can themselves be powered by PV cells operated for this particular purpose.

[0131] Although various types of specialized satellite modules, panels, and tiles for coordinating the distribution of reference signals and information throughout a space-based solar power station are described above with reference to FIGS. 5r and 5s, any of a variety of specialized elements can be utilized in the construction of space-based solar power stations as appropriate to the requirements of specific applications in accordance with embodiments of the invention. A variety of additional factors that can impact efficiency of received power transmitted by a space-based solar

power station constructed in accordance with various embodiments of the invention is discussed further below.

Factors Impact Efficiency of Power Transmissions from a Space-Based Solar Power Station

[0132] In many embodiments, the space-based solar power station is designed as a modular array where a plurality of satellite modules and power generating tiles located thereon form the elements of an antenna array. As can readily be appreciated, many factors can impact the efficiency of a given space-based solar power station constructed in accordance with various embodiments of the invention including (but not limited to) the size of the space-based solar power station, the number of satellite modules, number of panels per satellite module, number of power generation tiles per panel, antenna spacing, transmitted frequency of the wireless power transmission, and size of the rectenna array utilized to receive the transmitter power. The manner in which various design decisions can impact the performance of a space-based solar power stations in accordance with various embodiments of the invention is discussed further below.

[0133] A space-based solar power station can include N×N satellite modules, each satellite module including power generation tiles of

$$\frac{M}{N^2}$$

The number of power generation tiles in each satellite module, and the number of satellite modules in the solar power station may be determined based on, among other factors, power requirements, and/or payload restrictions. A factor that can impact the size of an overall solar power station is the power to be generated at the power receiving rectenna. As illustrated in FIG. 6a, the power incident on the ground using a far-field RF emission can have a maximum power lobe (u_{max}) that is dependent on factors including (but not limited to) the size of the array, the wavelength of the RF transmission, and the phase offset error tolerated within the phased array. For example, in embodiments of a 50×50 array of satellite modules in a solar power station formed by 60×60 m satellite modules a maximum power lobe of 926 W/m² is estimated to be generated on the ground with a sidelobe level of 44 W/m². The incident area of the maximum power lobe with a 1 GHz emission is estimated to have a diameter of 6.6 km, while the incident area is estimated to have a diameter of 2.8 km for a 2.4 GHz emission. From a power transmission point of view, the preferred number of elements in the antenna array formed by a space-based solar power station and the wavelength of the transmission will depend on the size of the receiving rectenna and/or array of

receiving rectennas. As shown in FIG. 6b, the efficiency of power transmission systems using different spacing of transmit antennas increases with the increased size of the receiver array. In many embodiments it is desirable to have the maximum power lobe on the ground coextensive with the rectenna area. In other embodiments, a rectenna area that is larger or smaller than the maximum power lobe can be utilized as appropriate to the requirements of specific applications. The manner in which the efficiency of power transmission is impacted by both the size of the array of antenna elements utilized to form the ground spot and the size of the rectenna array utilized to receive the transmitted power in accordance with various embodiments of the invention is illustrated in FIG. 6c. As can also be expected, the efficiency of the power transmission system increases with decreased spacing of the elements in the rectenna array.

[0134] The manner in which the frequency of the transmitted power signal impacts the spot size of the maximum power lobe generated by space-based solar power stations constructed in accordance with embodiments of the invention and located in geosynchronous and Low Earth Orbits (LEO) is illustrated in FIGS. 6d and 6e. As can readily be appreciated ground spot size decreases with increased transmission frequency.

[0135] The frequency of the transmitted power can also impact the distance of the Fresnel region boundary of the antenna array. The Fresnel region on an antenna or antenna array is the radiative near-field region of the transmitted RF signal. The Fresnel region boundary defines the boundary between the near-field and the far-field of the antenna or antenna array. As is illustrated in FIG. 6f, the pattern angle of the radiation pattern of an antenna in the near-field is much larger than the pattern angle of the radiation pattern of the antenna array in the far-field. Therefore, greater power transmission efficiency can be achieved using smaller rectenna arrays by designing an antenna array with a Fresnel region boundary that is less than the distance between the space-based solar power station and the receiver array. The relationship between the Fresnel region boundary and the size of the transmitter array at 1 GHz is illustrated in FIG. 6g. The altitude of a geostationary orbit is indicated on the chart shown in FIG. 6g, which suggests that arrays with side lengths exceeding 2 km will be less efficient than arrays having side lengths that are 1.5 km or less.

Comparative Performance

[0136] A number of alternative space-based solar power generation satellites have been proposed. Table 1 compares the published performance of various proposed solar power generation satellites with the estimated performance of a 60 m×60 m space-based solar power station constructed in accordance with various embodiments of the invention.

TABLE 1

Efficiency Standards	SPS Configuration Parameters				Exemplary Phased Array System Performance
	SPS Configuration	W/kg	Max Size		
Solar Cell Efficiency	35%				
DC-Microwave Conversion	78%	USEF	41	100 × 95 m	Power Received Power Received/Module
					12 GW 1.72 MW

TABLE 1-continued

Efficiency Standards	SPS Configuration Parameters			Exemplary Phased Array System Performance
	SPS Configuration	W/kg	Max Size	
Collection Efficiency	86% JAXA	98	3.5 km	Power Received Rectenna
Transmission Efficiency	77% ESA	132	15 km	Rectenna size: Total mass
Atmospheric Absorption	<2% Alpha	33	6 km (avg: 100 g/m ²)	900000 kg
Overall	14% Space-Based Solar Power Station	2270	60 × 60 m	

Assuming a Solar Power Station having a 50 × 50 array of 60 × 60 m satellite modules in a geosynchronous orbit with a 1 GHz power transmission having a $a/\lambda = 0.5$, and a solar irradiance of 1400 W/m².

[0137] The Exemplary Phased Array System Performance in Table 1 are estimates and may differ based on the actual design parameters implemented. As can readily be appreciated, however, the performance of the 60 m×60 m space-based solar power station constructed in accordance with embodiments of the invention provides a vastly improved W/kg performance relative to other proposed systems.

Generating Multiple Power Transmission Beams

[0138] The power transmission output **280** of the space-based solar power station **100** can be split between different rectenna power receivers **282**, as illustrated conceptually in FIG. 7. In many embodiments, different collections of elements (e.g., satellite modules and/or power generation tiles) forming part of the space-based solar power station **100** may be configured into different phased arrays that may be simultaneously directed at different rectenna power receivers **282** thus potentially reducing the individual incident areas radiated by the solar power station. In some embodiments additional control circuitry is provided either within the satellite module or within each of the power generation tiles to allow for dynamic electronic steering of the transmission beam, either from the collective power generation tiles of a satellite module or from each power generation tile independently. In some embodiments, the power steering circuitry may allow for the control of the relative timing (phase) of the various power transmitters on the power generation tile array elements, as illustrated conceptually in FIGS. **8a** and **8b**, such that each transmission beam may be redirected electronically at micro- and/or nano-second time scales. The power transmission from such dynamically steerable phased array on a solar power station allows for the entire phased array or portions thereof to be dynamically redirected in different directions dependent on demand at one or more rectenna power receivers. Embodiments of such dynamically directable phased arrays on power solar stations, may be used to redirect the power transmission in different directions at micro and nano-second time scales by electronic steering. Embodiments also allow for power transmissions to be dynamically distributed to various ground stations either simultaneously or sequentially based on instantaneous local demand. Power levels at each of such rectenna receivers may also be dynamically adjusted. Rapid time domain switching of power amongst rectenna receivers can also be used to control duty cycle and alleviate large scale AC synchronization issues with respect to an overall power grid.

[0139] A second factor that may constrain the number of array elements in any satellite module is the issue of payload size and weight. Current payload delivery technologies for geosynchronous orbits range from 2,000 to 20,000 kg. Accordingly, the limit to the size of any single satellite module is the actual lift capacity of available payload delivery vehicles. Based on an assumption of 100 g/m² for the phased array satellite modules according to embodiments, a 60×60 m satellite module would have a weight of 360 kg, well within the limits of current delivery technologies. Larger satellite modules could be produced provided they are within the lift capacity of available lift vehicles.

[0140] In some embodiments, satellite modules are compactable such that the size of the satellite module in one or more dimensions may be reduced during delivery to overcome payload space constraints and then expanded into its final operating configuration. As illustrated in FIGS. **9a** and **9b**, in many embodiments the solar power station **100** includes an array of satellite modules **102**, each satellite module comprising a plurality of structural elements **290** that are movably interconnected such that the plurality of structural elements may be moved between at least two configurations: a deployed configuration (FIG. **9a**) and a compacted configuration (**9b**), such that the ratio of the packaged volume to the material volume is larger in the deployed configuration when compared to the compacted or packaged configuration. In a number of embodiments, the structural elements **290** may be hinged, tessellated, folded or otherwise interconnected **292** such that the structural elements can move in relation to each other between the compacted and deployed configurations. Each satellite module of a solar power station may be configured to compact to the same or different sizes. In addition, different compacting methods may be used to compact one or more satellite modules of a solar space station, including, among others, one and two-dimensional compaction structures. In some embodiments, one or a combination of z-folding, wrapping, rolling, fan-folding, double z-folding, Miura-ori, slip folding and symmetric wrapping may be used, among others.

[0141] In many embodiments, the power generation tiles may have further compactible and expandable features and structures disposed thereon. In some embodiments of power generation tiles, the photovoltaic cell and power transmitter may be movably interrelated through a compactable structure, such that when in a compacted or packaged configuration the elements of the power generating cell are compressed together to occupy a total volume lower than when

in a deployed configuration. In some deployed configurations the photovoltaic cell and power transmitter are separated by a gap (e.g., to create a vertical offset therebetween). Embodiments of compactable structure include motorized interconnections and resilient members such as spring or tension arms that are bent or under compression, among others. Such compactable structures may also incorporate packaging techniques such as one or a combination of z-folding, wrapping, rolling, fan-folding, double z-folding, Miura-ori, slip folding and symmetric wrapping may be used, among others.

[0142] The power generation tiles and/or satellite modules may include other structures to enhance the collection of solar radiation or transmission of power from the power generation tiles and/or satellite modules. Embodiments of structures that may be incorporated into power generation tiles and/or satellite modules may include, among others, thermal radiators for controlling the thermal profile of the power generation tiles, light-collecting structures (e.g., radiators, reflectors and collectors) to enhance the efficiency of solar radiation collection to the photovoltaic cell, and radiation shielding to protect the photovoltaic cells, power transmitters and/or control electronics from space radiation. Such structures may also be independently compactible, between packaged and deployed configurations, as described above in relation to other elements of the power generation tiles.

[0143] A design for a satellite module or power generation tile may be applied to different satellite modules or power generation tiles. Other variables in the solar power station such as spatial distances, photovoltaics, power transmitter, control electronics and combinations with may be modified to produce a phased array with differing power collection and transmission characteristics. In this way, a diverse mix of solar power stations may be produced while maintaining the benefits of the modular solar power station described.

[0144] Although various designs of compatible satellite modules are described above, any of a variety of compactible space structures can be utilized in the construction of space-based solar power stations as appropriate to the requirements of specific applications in accordance with embodiments of the invention including (but not limited to) the various compactible space structures disclosed in U.S. patent application Ser. No. 14/712,812. The disclosure of U.S. patent application Ser. No. 14/712,812, is hereby incorporated by reference in its entirety, and more specifically the disclosure relevant to compactible space structures is incorporated herein by reference in its entirety.

[0145] While particular embodiments and applications of the present invention have been illustrated and described herein, it is to be understood that the invention is not limited to the precise construction and components disclosed herein and that various modifications, changes, and variations may be made in the arrangement, operation, and details of the methods and apparatuses of the present invention without departing from the spirit and scope of the invention as it is defined in the appended claims.

What is claimed is:

1. A space-based solar power station comprising:

- a plurality of unconnected satellite modules disposed in space in an orbital array formation;
- a plurality of power generation tiles disposed on each of the plurality of satellite modules;

at least one photovoltaic cell disposed on each of the power generation tiles; and

at least one power transmitter collocated with the at least one photovoltaic cell on each of the power generation tiles and in signal communication therewith such that an electrical current generated by the collection of solar radiation by the at least one photovoltaic cell powers the at least one power transmitter, where each of the at least one power transmitters comprises:

an antenna; and

control electronics that controls at least the phase of a radio frequency power signal that feeds the antenna so that the power transmitter is coordinated with power transmitters on other power generation tiles to form a phased array; and

at least one sun sensor disposed on the satellite module that is in signal communication with a microcontroller, where the microcontroller is in signal communication with the control electronics in each of the at least one power transmitter and provides a phase offset signal to the control electronics in each of the at least one power transmitter based upon at least one signal received from the at least one sun sensor.

2. The space-based solar power station of claim 1, wherein the control electronics further controls the amplitude of the radio frequency power signal that feeds the antenna so that the power transmitter is coordinated with power transmitters on other power generation tiles.

3. The space-based solar power station of claim 1, wherein:

the power transmitter is configured to receive a reference signal; and

the control electronics controls the phase of the radio frequency power signal by applying a phase shift with respect to the received reference signal.

4. The space-based solar power station of claim 3, wherein at least one of the satellite modules comprises a receiver to wirelessly receive the reference signal.

5. The space-based solar power station of claim 4, wherein the receiver of the at least one of the satellite module is configured to wirelessly receive the reference signal from an Earth-based transmitter.

6. The space-based solar power station of claim 4, further comprising:

a reference signal transmitter satellite comprising a transmitter that transmits the reference signal; and

wherein the receiver of the at least one of the satellite module is configured to wirelessly receive the reference signal from transmitter on the reference signal transmitter satellite.

7. The space-based solar power station of claim 4, wherein the receiver to wirelessly receive the reference signal comprises an amplifier, and a cleanup phase locked loop.

8. The space-based solar power station of claim 4, wherein each of the at least one satellite module also includes transmission lines that route the reference signal to at least one power transmitter on a given satellite module.

9. The space-based solar power station of claim 3, wherein the control electronics determine a phase shift to apply with respect to a received reference signal based upon location information.

10. The space-based solar power station of claim 1, wherein the at least one signal from the at least one sun

sensor comprises signals corresponding to the sensor's relative angle with respect to the sun.

11. The space-based solar power station of claim **10**, further comprising at least one accelerometer disposed on the satellite module that is in signal communication with the microcontroller.

12. The space-based solar power station of claim **10**, further comprising at least one gyroscope disposed on the satellite module that is in signal communication with the microcontroller.

13. The space-based solar power station of claim **10**, wherein the microcontroller is configured to integrate the at least one sun sensor signals to generate a finite model of the power generation tile.

14. The space-based solar power station of claim **13**, wherein the integration of the at least one sun sensor signals includes applying a Kalman filter to the at least one sun sensor signals.

15. The space-based solar power station of claim **13**, wherein the integration of the at least one sun sensor signals includes applying an extended Kalman filter to the at least one sun sensor signals.

16. The space-based solar power station of claim **13**, wherein the microcontroller is further configured to estimate the shape of the power generation tile with respect to the sun.

17. The space-based solar power station of claim **13**, wherein the microcontroller is further configured to estimate the relative position of the antennas in the power transmitters with respect to each other.

18. The space-based solar power station of claim **17**, wherein the microcontroller is further configured to communicate a signal to the control electronics to adjust the reference signal based upon the estimated relative positions of the antennas in the power transmitters with respect to each other.

19. The space-based solar power station of claim **1**, wherein the control electronics is contained within an integrated circuit comprising:

- an RF synthesizer configured to generate an RF signal based upon a received reference signal;
- a phase adjuster configured to phase shift an RF signal received from the RF synthesizer by an amount determined by a control signal;
- a power amplifier configured to amplify a phase shifted RF signal received from the phase adjuster; and
- a digital signal processor configured by software stored in memory to generate the control signal for the phase adjuster.

20. A satellite module, comprising:

- a plurality of power generation tiles;
- at least one photovoltaic cell disposed on each of the power generation tiles; and
- at least one power transmitter collocated with the at least one photovoltaic cell on each of the power generation tiles and in signal communication therewith such that an electrical current generated by the collection of solar radiation by the at least one photovoltaic cell powers the at least one power transmitter, where each of the at least one power transmitters comprises:
 - an antenna; and
 - control electronics that controls at least the phase of a radio frequency power signal that feeds the antenna so that the power transmitter is coordinated with power transmitters on other power generation tiles to form a phased array; and
- at least one sun sensor disposed on the satellite module that is in signal communication with a microcontroller, where the microcontroller is in signal communication with the control electronics of the at least one power transmitter therewith such that a phase offset signal to the control electronics in each of the at least one power transmitter based upon at least one signal received from the at least one sun sensor.

21. A power generation tile, comprising:

- at least one photovoltaic cell; and
- at least one power transmitter collocated with the at least one photovoltaic cell and in signal communication therewith such that an electrical current generated by the collection of solar radiation by the at least one photovoltaic cell powers the at least one power transmitter, where each of the at least one power transmitters comprises:
 - an antenna; and
 - control electronics that controls at least the phase of a radio frequency power signal that feeds the antenna; and
- at least one sun sensor in signal communication with a microcontroller, where the microcontroller is in signal communication with the control electronics of the at least one power transmitter therewith such that a phase offset signal to the control electronics in each of the at least one power transmitter based upon at least one signal received from the at least one sun sensor.

* * * * *