

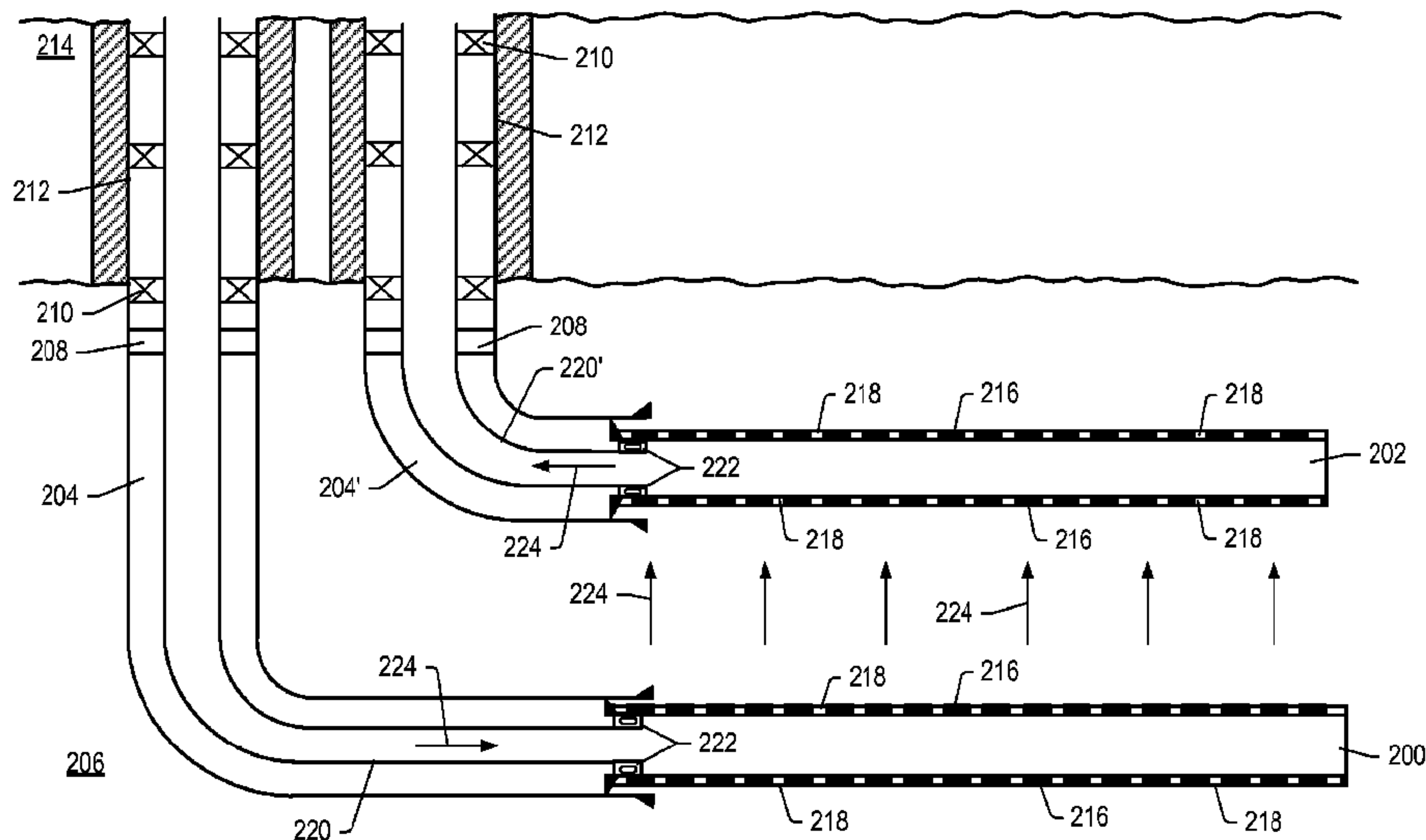

(86) Date de dépôt PCT/PCT Filing Date: 2009/10/09
 (87) Date publication PCT/PCT Publication Date: 2010/04/22
 (45) Date de délivrance/Issue Date: 2018/01/02
 (85) Entrée phase nationale/National Entry: 2011/03/30
 (86) N° demande PCT/PCT Application No.: US 2009/060100
 (87) N° publication PCT/PCT Publication No.: 2010/045103
 (30) Priorités/Priorities: 2008/10/13 (US61/104,974);
 2009/04/10 (US61/168,498)

(51) Cl.Int./Int.Cl. *E21B 43/24* (2006.01),
E21B 36/00 (2006.01)
 (72) Inventeurs/Inventors:
 ARORA, DHUV, US;
 AYODELE, OLUROPO RUFUS, US;
 KARANIKAS, JOHN MICHAEL, US;
 SANDBERG, CHESTER LEDLIE, US;
 VINEGAR, HAROLD J., US;
 XIE, XUEYING, US;
 HARRIS, CHRISTOPHER KELVIN, CA
 (73) Propriétaire/Owner:
 SHELL INTERNATIONALE RESEARCH
 MAATSCHAPPIJ B.V., NL
 (74) Agent: SMART & BIGGAR

(54) Titre : SYSTEMES ET PROCEDES DE TRAITEMENT D'UNE FORMATION SOUTERRAINE AU MOYEN DE CONDUCTEURS ELECTRIQUES
 (54) Title: SYSTEMS AND METHODS FOR TREATING A SUBSURFACE FORMATION WITH ELECTRICAL CONDUCTORS



(57) Abrégé/Abstract:

Systems and methods for treating a subsurface formation are described herein. The system includes a wellbore at least partially located in a hydrocarbon containing formation. The wellbore includes a substantially vertical portion and at least two substantially

(57) **Abrégé(suite)/Abstract(continued):**

horizontally oriented or inclined portions coupled to the vertical portion. A first conductor is at least partially positioned in a first of the two substantially horizontal oriented or inclined portions of the wellbore and includes electrically conductive material. A power supply is coupled to at least the first conductor and is configured to electrically excite the electrically conductive materials of the first conductor such that current flows between the electrically conductive materials in the first conductor, through at least a portion of the formation, to a second conductor and heats at least a portion of the formation between the two substantially horizontally oriented or inclined portions of the wellbore.

(12) INTERNATIONAL APPLICATION PUBLISHED UNDER THE PATENT COOPERATION TREATY (PCT)

(19) World Intellectual Property Organization
International Bureau(43) International Publication Date
22 April 2010 (22.04.2010)(10) International Publication Number
WO 2010/045103 A1(51) International Patent Classification:
E21B 43/24 (2006.01)(21) International Application Number:
PCT/US2009/060100(22) International Filing Date:
9 October 2009 (09.10.2009)

(25) Filing Language: English

(26) Publication Language: English

(30) Priority Data:
61/104,974 13 October 2008 (13.10.2008) US
61/168,498 10 April 2009 (10.04.2009) US(71) Applicant (for SM only): **SHELL OIL COMPANY**
[US/US]; One Shell Plaza, P.O. Box 2463, Houston,
Texas 77252-2463 (US).(71) Applicant (for all designated States except US): **SHELL
INTERNATIONALE RESEARCH MAATSCHAPPIJ
B.V.** [NL/NL]; Carel van Bylandtlaan 30, NL-2596 HR
The Hague (NL).

(72) Inventors; and

(75) Inventors/Applicants (for US only): **ARORA, Dhruv**
[IN/US]; 7675 Phoenix Drive, Apt. 836, Houston, Texas
77030 (US). **AYODELE, Oluropo Rufus** [CA/US];
25102 Diamond Ranch Drive, Katy, Texas 77494 (US).
HARRIS, Christopher Kelvin [GB/CA]; 2 Varbay Place
NW, Calgary, T3A 0C8 (CA). **KARANIKAS, John
Michael** [GR/US]; 1005A Crocker Street, Houston, Texas
77019 (US). **SANDBERG, Chester Ledlie** [US/US]; 758Torreya Ct., Palo Alto, California 94303 (US). **VINE-
GAR, Harold J.** [US/US]; 4613 Laurel, Bellaire, Texas
77401 (US). **XIE, Xueying** [CN/US]; 2727 West 18th
Street, 328, Houston, Texas 77008 (US).(74) Agent: **CHRISTENSEN, Del S.**; Shell Oil Company,
One Shell Plaza, P.O. Box 2463, Houston, Texas
77252-2463 (US).(81) Designated States (unless otherwise indicated, for every
kind of national protection available): AE, AG, AL, AM,
AO, AT, AU, AZ, BA, BB, BG, BH, BR, BW, BY, BZ,
CA, CH, CL, CN, CO, CR, CU, CZ, DE, DK, DM, DO,
DZ, EC, EE, EG, ES, FI, GB, GD, GE, GH, GM, GT,
HN, HR, HU, ID, IL, IN, IS, JP, KE, KG, KM, KN, KP,
KR, KZ, LA, LC, LK, LR, LS, LT, LU, LY, MA, MD,
ME, MG, MK, MN, MW, MX, MY, MZ, NA, NG, NI,
NO, NZ, OM, PE, PG, PH, PL, PT, RO, RS, RU, SC, SD,
SE, SG, SK, SL, SM, ST, SV, SY, TJ, TM, TN, TR, TT,
TZ, UA, UG, US, UZ, VC, VN, ZA, ZM, ZW.(84) Designated States (unless otherwise indicated, for every
kind of regional protection available): ARIPO (BW, GH,
GM, KE, LS, MW, MZ, NA, SD, SL, SZ, TZ, UG, ZM,
ZW), Eurasian (AM, AZ, BY, KG, KZ, MD, RU, TJ,
TM), European (AT, BE, BG, CH, CY, CZ, DE, DK, EE,
ES, FI, FR, GB, GR, HR, HU, IE, IS, IT, LT, LU, LV,
MC, MK, MT, NL, NO, PL, PT, RO, SE, SI, SK, SM,
TR), OAPI (BF, BJ, CF, CG, CI, CM, GA, GN, GQ, GW,
ML, MR, NE, SN, TD, TG).

[Continued on next page]

(54) Title: SYSTEMS AND METHODS FOR TREATING A SUBSURFACE FORMATION WITH ELECTRICAL CONDUCTORS

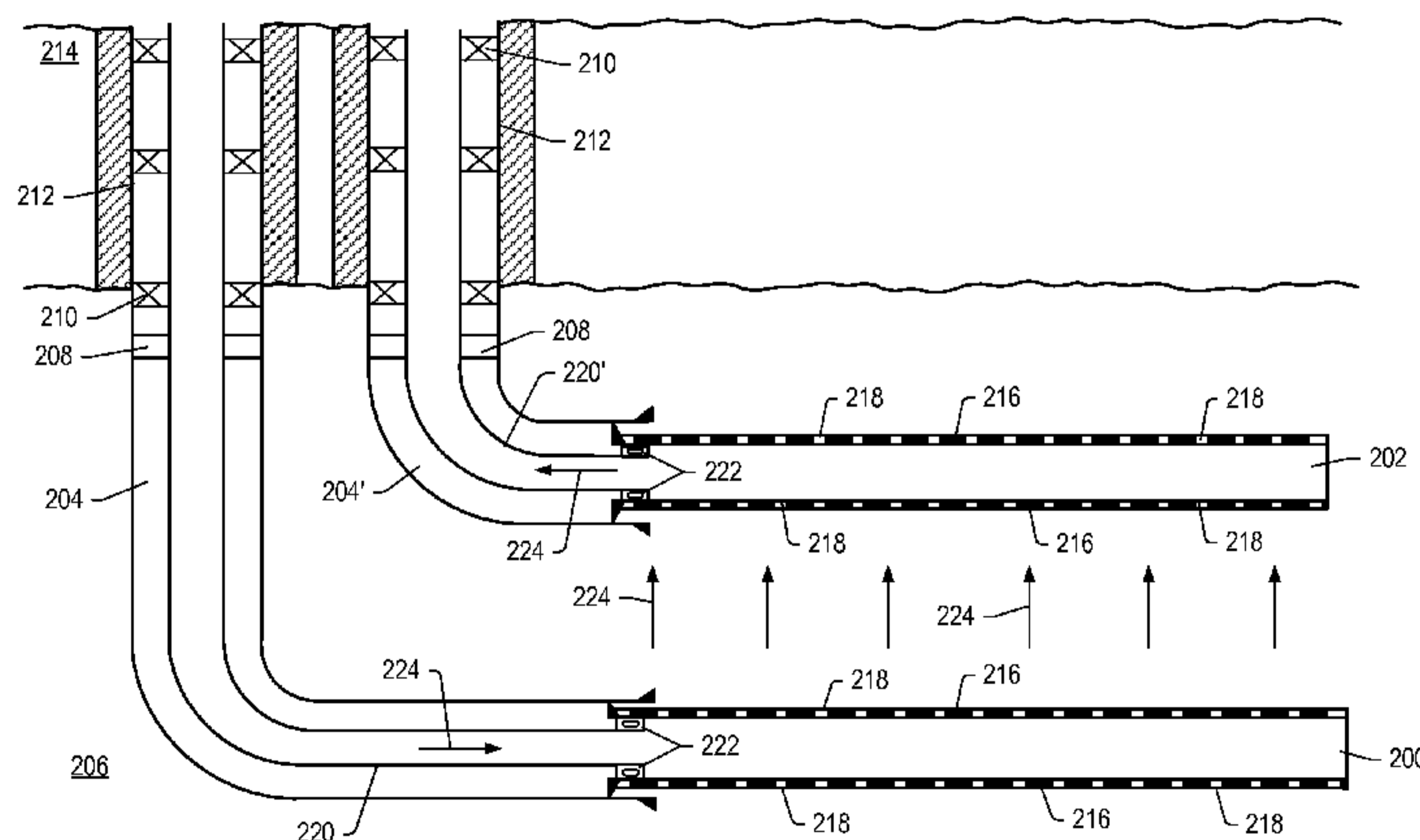

FIG. 2

(57) Abstract: Systems and methods for treating a subsurface formation are described herein. The system includes a wellbore at least partially located in a hydrocarbon containing formation. The wellbore includes a substantially vertical portion and at least two substantially horizontally oriented or inclined portions coupled to the vertical portion. A first conductor is at least partially positioned in a first of the two substantially horizontal oriented or inclined portions of the wellbore and includes electrically conductive material. A power supply is coupled to at least the first conductor and is configured to electrically excite the electrically conductive materials of the first conductor such that current flows between the electrically conductive materials in the first conductor, through at least a portion of the formation, to a second conductor and heats at least a portion of the formation between the two substantially horizontal or inclined portions of the wellbore.

WO 2010/045103 A1 

Published:

— *with international search report (Art. 21(3))*

SYSTEMS AND METHODS FOR TREATING A SUBSURFACE FORMATION WITH
ELECTRICAL CONDUCTORS

BACKGROUND

5 1. Field of the Invention

[0001] The present invention relates generally to systems, methods and heat sources for production of hydrocarbons, hydrogen, and/or other products. The present invention relates in particular to systems and methods using heat sources for treating various subsurface hydrocarbon formations.

10 2. Description of Related Art

[0002] Hydrocarbons obtained from subterranean formations are often used as energy resources, as feedstocks, and as consumer products. Concerns over depletion of available hydrocarbon resources and concerns over declining overall quality of produced hydrocarbons have led to development of processes for more efficient recovery, processing and/or use of available hydrocarbon resources. In situ processes may be used to remove hydrocarbon materials from subterranean formations. Chemical and/or physical properties of hydrocarbon material in a subterranean formation may need to be changed to allow hydrocarbon material to be more easily removed from the subterranean formation. The chemical and physical changes may include in situ reactions that produce removable fluids, composition changes, solubility changes, density changes, phase changes, and/or viscosity changes of the hydrocarbon material in the formation. A fluid may be, but is not limited to, a gas, a liquid, an emulsion, a slurry, and/or a stream of solid particles that has flow characteristics similar to liquid flow.

[0003] Subsurface formations (for example, tar sands or heavy hydrocarbon formations) include dielectric media. Dielectric media may exhibit conductivity, relative dielectric constant, and loss tangents at temperatures below 100 °C. Loss of conductivity, relative dielectric constant, and dissipation factor may occur as the formation is heated to temperatures above 100 °C due to the loss of moisture contained in the interstitial spaces in the rock matrix of the formation. To prevent loss of moisture, formations may be heated at temperatures and pressures that minimize vaporization of water. Conductive solutions may be added to the formation to help maintain the electrical properties of the formation.

[0004] Formations may be heated using electrodes to temperatures and pressures that vaporize the water and/or conductive solutions. Material used to produce the current flow,

however, may become damaged due to heat stress and/or loss of conductive solutions may limit heat transfer in the layer. In addition, when using electrodes, magnetic fields may form. Due to the presence of magnetic fields, non-ferromagnetic materials may be desired for overburden casings.

5 [0005] U.S. Patent No. 4,084,637 to Todd describes methods of producing viscous materials from subterranean formations that includes passing electrical current through the subterranean formation. As the electrical current passes through the subterranean formation, the viscous material is heated to thereby lower the viscosity of such material. Following the heating of the subterranean formation in the vicinity of the path formed by
10 the electrode wells, a driving fluid is injected through the injection wells to thereby migrate along the path and force the material having a reduced viscosity toward the production well. The material is produced through the production well and by continuing to inject a heated fluid through the injection wells, substantially all of the viscous material in the subterranean formation can be heated to lower its viscosity and be produced from the
15 production well.

[0006] U.S. Patent No. 4,926,941 to Glandt et al. describes producing thick tar sand deposits by preheating of thin, relatively conductive layers which are a small fraction of the total thickness of a tar sand deposit. The thin conductive layers serve to confine the heating within the tar sands to a thin zone adjacent to the conductive layers even for large distances
20 between rows of electrodes. The preheating is continued until the viscosity of the tar in a thin preheated zone adjacent to the conductive layers is reduced sufficiently to allow steam injection into the tar sand deposit. The entire deposit is then produced by steam flooding.

[0007] U.S. Patent No. 5,046,559 to Glandt describe an apparatus and method for producing thick tar sand deposits by electrically preheating paths of increased injectivity
25 between an injector and producers. The injector and producers are arranged in a triangular pattern with the injector located at the apex and the producers located on the base of the triangle. These paths of increased injectivity are then steam flooded to produce the hydrocarbons.

[0008] As discussed above, there has been a significant amount of effort to develop
30 methods and systems to economically produce hydrocarbons, hydrogen, and/or other products from hydrocarbon containing formations. At present, however, there are still many hydrocarbon containing formations from which hydrocarbons, hydrogen, and/or other products cannot be economically produced. Thus, there is a need for improved

63293-4304

methods and systems for heating of a hydrocarbon formation and production of fluids from the hydrocarbon formation. There is also a need for improved methods and systems that reduce energy costs for treating the formation, reduce emissions from the treatment process, facilitate heating system installation, and/or reduce heat loss to the overburden as compared to hydrocarbon recovery processes that utilize surface based equipment.

SUMMARY

[0009] Embodiments described herein generally relate to systems, methods, and heat sources for treating a subsurface formation. Embodiments described herein also generally relate to electrically conducting material that have novel components therein. Such heat sources can be obtained by using the systems and methods described herein.

[0010] In certain embodiments, the invention provides one or more systems, methods, and/or electrically conducting materials. In some embodiments, the systems, methods, and/or electrically conducting material are used for treating a subsurface formation.

[0011] The invention, in some embodiments, provides a system for treating a system for treating a subsurface formation, comprising: a wellbore at least partially located in a hydrocarbon containing formation, the wellbore comprising a substantially vertical portion and at least two substantially horizontal or inclined portions coupled to the vertical portion; a first conductor at least partially positioned in a first of the two substantially horizontal or inclined portions of the wellbore, wherein the first conductor comprises electrically conductive materials; a second conductor at least partially positioned in a second of the two substantially horizontal or inclined portions of the wellbore, wherein the second conductor comprises electrically conductive materials; and a power supply coupled to at least the first conductor, the power supply configured to electrically excite the electrically conductive materials of the first conductor such that electrical current flows from the electrically conductive materials in the first conductor, through at least a portion of the formation, to the second conductor and heats at least a portion of the formation between the two substantially horizontal or inclined portions of the wellbore.

63293-4304

[0012] The invention provides, in some embodiments, a method for treating a subsurface formation, comprising: providing a wellbore at least partially located in the formation, the wellbore comprising a substantially vertical portion and at least two substantially horizontal or inclined portions coupled to the vertical portion; providing a first conductor at least partially positioned in a first of the two substantially horizontal or inclined portions of the wellbore, wherein the first conductor comprises electrically conductive materials; providing a second conductor at least partially positioned in a second of the two substantially horizontal or inclined portions of the wellbore, wherein the first conductor comprises electrically conductive materials; and providing electrical current to the first conductor to electrically excite the electrically conductive materials of the first conductor such that electrical current flows from the electrically conductive materials in the first conductor, through at least a portion of the formation, to the electrically conductive materials in the second conductor to heat at least a portion of the formation between the two substantially horizontal or inclined portions of the wellbore.

[0013] In further embodiments, features from specific embodiments may be combined with features from other embodiments. For example, features from one embodiment may be combined with features from any of the other embodiments. In further embodiments, treating a subsurface formation is performed using any of the methods, systems, or
5 electrically conducting materials described herein. In further embodiments, additional features may be added to the specific embodiments described herein.

BRIEF DESCRIPTION OF THE DRAWINGS

[0014] Advantages of the present invention may become apparent to those skilled in the art with the benefit of the following detailed description and upon reference to the
10 accompanying drawings.

[0015] FIG. 1 shows a schematic view of an embodiment of a portion of an in situ heat treatment system for treating a hydrocarbon containing formation.

[0016] FIG. 2 depicts a schematic of an embodiment for treating a subsurface formation using heat sources having electrically conductive material.

15 [0017] FIG. 3 depicts a schematic of an embodiment for treating a subsurface formation using a ground and heat sources having electrically conductive material.

[0018] FIG. 4 depicts a schematic of an embodiment for treating a subsurface formation using heat sources having electrically conductive material and an electrical insulator.

20 [0019] FIG. 5 depicts a schematic of an embodiment for treating a subsurface formation using electrically conductive heat sources extending from a common wellbore.

[0020] FIG. 6 depicts a schematic of an embodiment for treating a subsurface formation having a shale layer using heat sources having electrically conductive material.

[0021] While the invention is susceptible to various modifications and alternative forms, specific embodiments thereof are shown by way of example in the drawings and may
25 herein be described in detail. The drawings may not be to scale. It should be understood, however, that the drawings and detailed description thereto are not intended to limit the invention to the particular form disclosed, but on the contrary, the intention is to cover all modifications, equivalents and alternatives falling within the spirit and scope of the present invention as defined by the appended claims.

DETAILED DESCRIPTION

30 [0022] Although many methods have been described for heating formations using electrodes, efficient and economic methods of heating and producing hydrocarbons using heat sources with electrically conductive material are needed. The following description

generally relates to systems and methods for treating hydrocarbons in the formations using heat sources with electrically conductive material. Such formations may be treated to yield hydrocarbon products, hydrogen, and other products.

5 [0023] “API gravity” refers to API gravity at 15.5 °C (60 °F). API gravity is as determined by ASTM Method D6822 or ASTM Method D1298.

[0024] “Fluid pressure” is a pressure generated by a fluid in a formation. “Lithostatic pressure” (sometimes referred to as “lithostatic stress”) is a pressure in a formation equal to a weight per unit area of an overlying rock mass. “Hydrostatic pressure” is a pressure in a formation exerted by a column of water.

10 [0025] A “formation” includes one or more hydrocarbon containing layers, one or more non-hydrocarbon layers, an overburden, and/or an underburden. “Hydrocarbon layers” refer to layers in the formation that contain hydrocarbons. The hydrocarbon layers may contain non-hydrocarbon material and hydrocarbon material. The “overburden” and/or the “underburden” include one or more different types of impermeable materials. For
15 example, the overburden and/or underburden may include rock, shale, mudstone, or wet/tight carbonate. In some embodiments of in situ heat treatment processes, the overburden and/or the underburden may include a hydrocarbon containing layer or hydrocarbon containing layers that are relatively impermeable and are not subjected to temperatures during in situ heat treatment processing that result in significant characteristic
20 changes of the hydrocarbon containing layers of the overburden and/or the underburden. For example, the underburden may contain shale or mudstone, but the underburden is not allowed to heat to pyrolysis temperatures during the in situ heat treatment process. In some cases, the overburden and/or the underburden may be somewhat permeable.

25 [0026] “Formation fluids” refer to fluids present in a formation and may include pyrolyzation fluid, synthesis gas, mobilized hydrocarbons, and water (steam). Formation fluids may include hydrocarbon fluids as well as non-hydrocarbon fluids. The term “mobilized fluid” refers to fluids in a hydrocarbon containing formation that are able to flow as a result of thermal treatment of the formation. “Produced fluids” refer to fluids removed from the formation.

30 [0027] A “heat source” is any system for providing heat to at least a portion of a formation substantially by conductive and/or radiative heat transfer. For example, a heat source may include electrically conducting materials and/or electric heaters such as an insulated conductor, an elongated member, and/or a conductor disposed in a conduit. A heat source

may also include systems that generate heat by burning a fuel external to or in a formation. The systems may be surface burners, downhole gas burners, flameless distributed combustors, and natural distributed combustors. In some embodiments, heat provided to or generated in one or more heat sources may be supplied by other sources of energy. The other sources of energy may directly heat a formation, or the energy may be applied to a transfer medium that directly or indirectly heats the formation. It is to be understood that one or more heat sources that are applying heat to a formation may use different sources of energy. Thus, for example, for a given formation some heat sources may supply heat from electrically conducting materials, electric resistance heaters, some heat sources may provide heat from combustion, and some heat sources may provide heat from one or more other energy sources (for example, chemical reactions, solar energy, wind energy, biomass, or other sources of renewable energy). A chemical reaction may include an exothermic reaction (for example, an oxidation reaction). A heat source may also include a electrically conducting material and/or a heater that provides heat to a zone proximate and/or surrounding a heating location such as a heater well.

[0028] A “heater” is any system or heat source for generating heat in a well or a near wellbore region. Heaters may be, but are not limited to, electric heaters, burners, combustors that react with material in or produced from a formation, and/or combinations thereof.

[0029] “Heavy hydrocarbons” are viscous hydrocarbon fluids. Heavy hydrocarbons may include highly viscous hydrocarbon fluids such as heavy oil, tar, and/or asphalt. Heavy hydrocarbons may include carbon and hydrogen, as well as smaller concentrations of sulfur, oxygen, and nitrogen. Additional elements may also be present in heavy hydrocarbons in trace amounts. Heavy hydrocarbons may be classified by API gravity. Heavy hydrocarbons generally have an API gravity below about 20°. Heavy oil, for example, generally has an API gravity of about 10-20°, whereas tar generally has an API gravity below about 10°. The viscosity of heavy hydrocarbons is generally greater than about 100 centipoise at 15 °C. Heavy hydrocarbons may include aromatics or other complex ring hydrocarbons.

[0030] Heavy hydrocarbons may be found in a relatively permeable formation. The relatively permeable formation may include heavy hydrocarbons entrained in, for example, sand or carbonate. “Relatively permeable” is defined, with respect to formations or portions thereof, as an average permeability of 10 millidarcy or more (for example, 10 or

100 millidarcy). “Relatively low permeability” is defined, with respect to formations or portions thereof, as an average permeability of less than about 10 millidarcy. One darcy is equal to about 0.99 square micrometers. An impermeable layer generally has a permeability of less than about 0.1 millidarcy.

5 [0031] Certain types of formations that include heavy hydrocarbons may also include, but are not limited to, natural mineral waxes, or natural asphaltites. “Natural mineral waxes” typically occur in substantially tubular veins that may be several meters wide, several kilometers long, and hundreds of meters deep. “Natural asphaltites” include solid hydrocarbons of an aromatic composition and typically occur in large veins. In situ
10 recovery of hydrocarbons from formations such as natural mineral waxes and natural asphaltites may include melting to form liquid hydrocarbons and/or solution mining of hydrocarbons from the formations.

[0032] “Hydrocarbons” are generally defined as molecules formed primarily by carbon and hydrogen atoms. Hydrocarbons may also include other elements such as, but not limited
15 to, halogens, metallic elements, nitrogen, oxygen, and/or sulfur. Hydrocarbons may be, but are not limited to, kerogen, bitumen, pyrobitumen, oils, natural mineral waxes, and asphaltites. Hydrocarbons may be located in or adjacent to mineral matrices in the earth. Matrices may include, but are not limited to, sedimentary rock, sands, silicilytes, carbonates, diatomites, and other porous media. “Hydrocarbon fluids” are fluids that
20 include hydrocarbons. Hydrocarbon fluids may include, entrain, or be entrained in non-hydrocarbon fluids such as hydrogen, nitrogen, carbon monoxide, carbon dioxide, hydrogen sulfide, water, and ammonia.

[0033] An “in situ conversion process” refers to a process of heating a hydrocarbon containing formation from heat sources to raise the temperature of at least a portion of the
25 formation above a pyrolysis temperature so that pyrolyzation fluid is produced in the formation.

[0034] An “in situ heat treatment process” refers to a process of heating a hydrocarbon containing formation with heat sources to raise the temperature of at least a portion of the
30 formation above a temperature that results in mobilized fluid, visbreaking, and/or pyrolysis of hydrocarbon containing material so that mobilized fluids, visbroken fluids, and/or pyrolyzation fluids are produced in the formation.

[0035] “Insulated conductor” refers to any elongated material that is able to conduct electricity and that is covered, in whole or in part, by an electrically insulating material.

[0036] "Pyrolysis" is the breaking of chemical bonds due to the application of heat. For example, pyrolysis may include transforming a compound into one or more other substances by heat alone. Heat may be transferred to a section of the formation to cause pyrolysis.

5 [0037] "Pyrolyzation fluids" or "pyrolysis products" refers to fluid produced substantially during pyrolysis of hydrocarbons. Fluid produced by pyrolysis reactions may mix with other fluids in a formation. The mixture would be considered pyrolyzation fluid or pyrolyzation product. As used herein, "pyrolysis zone" refers to a volume of a formation (for example, a relatively permeable formation such as a tar sands formation) that is
10 reacted or reacting to form a pyrolyzation fluid.

[0038] "Superposition of heat" refers to providing heat from two or more heat sources to a selected section of a formation such that the temperature of the formation at least at one location between the heat sources is influenced by the heat sources.

[0039] A "tar sands formation" is a formation in which hydrocarbons are predominantly
15 present in the form of heavy hydrocarbons and/or tar entrained in a mineral grain framework or other host lithology (for example, sand or carbonate). Examples of tar sands formations include formations such as the Athabasca formation, the Grosmont formation, and the Peace River formation, all three in Alberta, Canada; and the Faja formation in the Orinoco belt in Venezuela.

20 [0040] "Thickness" of a layer refers to the thickness of a cross section of the layer, wherein the cross section is normal to a face of the layer.

[0041] A "u-shaped wellbore" refers to a wellbore that extends from a first opening in the formation, through at least a portion of the formation, and out through a second opening in the formation. In this context, the wellbore may be only roughly in the shape of a "v" or
25 "u", with the understanding that the "legs" of the "u" do not need to be parallel to each other, or perpendicular to the "bottom" of the "u" for the wellbore to be considered "u-shaped".

[0042] "Visbreaking" refers to the untangling of molecules in fluid during heat treatment and/or to the breaking of large molecules into smaller molecules during heat treatment,
30 which results in a reduction of the viscosity of the fluid.

[0043] The term "wellbore" refers to a hole in a formation made by drilling or insertion of a conduit into the formation. A wellbore may have a substantially circular cross section, or another cross-sectional shape. As used herein, the terms "well" and "opening," when

referring to an opening in the formation may be used interchangeably with the term “wellbore.”

5 [0044] A formation may be treated in various ways to produce many different products. Different stages or processes may be used to treat the formation during an in situ heat treatment process. In some embodiments, one or more sections of the formation are solution mined to remove soluble minerals from the sections. Solution mining minerals may be performed before, during, and/or after the in situ heat treatment process. In some embodiments, the average temperature of one or more sections being solution mined may be maintained below about 120 °C.

10 [0045] In some embodiments, one or more sections of the formation are heated to remove water from the sections and/or to remove methane and other volatile hydrocarbons from the sections. In some embodiments, the average temperature may be raised from ambient temperature to temperatures below about 220 °C during removal of water and volatile hydrocarbons.

15 [0046] In some embodiments, one or more sections of the formation are heated to temperatures that allow for movement and/or visbreaking of hydrocarbons in the formation. In some embodiments, the average temperature of one or more sections of the formation are raised to mobilization temperatures of hydrocarbons in the sections (for example, to temperatures ranging from 100 °C to 250 °C, from 120 °C to 240 °C, or from
20 150 °C to 230 °C).

[0047] In some embodiments, one or more sections are heated to temperatures that allow for pyrolysis reactions in the formation. In some embodiments, the average temperature of one or more sections of the formation may be raised to pyrolysis temperatures of hydrocarbons in the sections (for example, temperatures ranging from 230 °C to 900 °C,
25 from 240 °C to 400 °C or from 250 °C to 350 °C).

[0048] Heating the hydrocarbon containing formation with a plurality of heat sources may establish thermal gradients around the heat sources that raise the temperature of hydrocarbons in the formation to desired temperatures at desired heating rates. The rate of temperature increase through mobilization temperature range and/or pyrolysis temperature
30 range for desired products may affect the quality and quantity of the formation fluids produced from the hydrocarbon containing formation. Slowly raising the temperature of the formation through the mobilization temperature range and/or pyrolysis temperature range may allow for the production of high quality, high API gravity hydrocarbons from

the formation. Slowly raising the temperature of the formation through the mobilization temperature range and/or pyrolysis temperature range may allow for the removal of a large amount of the hydrocarbons present in the formation as hydrocarbon product.

5 [0049] In some in situ heat treatment embodiments, a portion of the formation is heated to a desired temperature instead of slowly heating the temperature through a temperature range. In some embodiments, the desired temperature is 300 °C, 325 °C, or 350 °C. Other temperatures may be selected as the desired temperature.

10 [0050] Superposition of heat from heat sources allows the desired temperature to be relatively quickly and efficiently established in the formation. Energy input into the formation from the heat sources may be adjusted to maintain the temperature in the formation substantially at a desired temperature.

15 [0051] Mobilization and/or pyrolysis products may be produced from the formation through production wells. In some embodiments, the average temperature of one or more sections is raised to mobilization temperatures and hydrocarbons are produced from the production wells. The average temperature of one or more of the sections may be raised to pyrolysis temperatures after production due to mobilization decreases below a selected value. In some embodiments, the average temperature of one or more sections may be raised to pyrolysis temperatures without significant production before reaching pyrolysis temperatures. Formation fluids including pyrolysis products may be produced through the production wells.

20 [0052] In some embodiments, the average temperature of one or more sections may be raised to temperatures sufficient to allow synthesis gas production after mobilization and/or pyrolysis. In some embodiments, hydrocarbons may be raised to temperatures sufficient to allow synthesis gas production without significant production before reaching the temperatures sufficient to allow synthesis gas production. For example, synthesis gas may be produced in a temperature range from about 400 °C to about 1200 °C, about 500 °C to about 1100 °C, or about 550 °C to about 1000 °C. A synthesis gas generating fluid (for example, steam and/or water) may be introduced into the sections to generate synthesis gas. Synthesis gas may be produced from production wells.

30 [0053] Solution mining, removal of volatile hydrocarbons and water, mobilizing hydrocarbons, pyrolyzing hydrocarbons, generating synthesis gas, and/or other processes may be performed during the in situ heat treatment process. In some embodiments, some processes may be performed after the in situ heat treatment process. Such processes may

include, but are not limited to, recovering heat from treated sections, storing fluids (for example, water and/or hydrocarbons) in previously treated sections, and/or sequestering carbon dioxide in previously treated sections.

[0054] FIG. 1 depicts a schematic view of an embodiment of a portion of the in situ heat treatment system for treating the hydrocarbon containing formation. The in situ heat treatment system may include barrier wells 100. Barrier wells are used to form a barrier around a treatment area. The barrier inhibits fluid flow into and/or out of the treatment area. Barrier wells include, but are not limited to, dewatering wells, vacuum wells, capture wells, injection wells, grout wells, freeze wells, or combinations thereof. In some embodiments, barrier wells 100 are dewatering wells. Dewatering wells may remove liquid water and/or inhibit liquid water from entering a portion of the formation to be heated, or to the formation being heated. In the embodiment depicted in FIG. 1, the barrier wells 100 are shown extending only along one side of heat sources 102, but the barrier wells typically encircle all heat sources 102 used, or to be used, to heat a treatment area of the formation.

[0055] Heat sources 102 are placed in at least a portion of the formation. Heat sources 102 may include electrically conducting material. In some embodiments, heat sources include heaters such as insulated conductors, conductor-in-conduit heaters, surface burners, flameless distributed combustors, and/or natural distributed combustors. Heat sources 102 may also include other types of heaters. Heat sources 102 provide heat to at least a portion of the formation to heat hydrocarbons in the formation. Energy may be supplied to heat sources 102 through supply lines 104. Supply lines 104 may be structurally different depending on the type of heat source or heat sources used to heat the formation. Supply lines 104 for heat sources may transmit electricity for electrically conducting material or electric heaters, may transport fuel for combustors, or may transport heat exchange fluid that is circulated in the formation. In some embodiments, electricity for an in situ heat treatment process may be provided by a nuclear power plant or nuclear power plants. The use of nuclear power may allow for reduction or elimination of carbon dioxide emissions from the in situ heat treatment process.

[0056] Heating the formation may cause an increase in permeability and/or porosity of the formation. Increases in permeability and/or porosity may result from a reduction of mass in the formation due to vaporization and removal of water, removal of hydrocarbons, and/or creation of fractures. Fluid may flow more easily in the heated portion of the

formation because of the increased permeability and/or porosity of the formation. Fluid in the heated portion of the formation may move a considerable distance through the formation because of the increased permeability and/or porosity. The considerable distance may be over 1000 m depending on various factors, such as permeability of the formation, properties of the fluid, temperature of the formation, and pressure gradient allowing movement of the fluid. The ability of fluid to travel considerable distance in the formation allows production wells 106 to be spaced relatively far apart in the formation. [0057] Production wells 106 are used to remove formation fluid from the formation. In some embodiments, production well 106 includes a heat source. The heat source in the production well may heat one or more portions of the formation at or near the production well. In some in situ heat treatment process embodiments, the amount of heat supplied to the formation from the production well per meter of the production well is less than the amount of heat applied to the formation from a heat source that heats the formation per meter of the heat source. Heat applied to the formation from the production well may increase formation permeability adjacent to the production well by vaporizing and removing liquid phase fluid adjacent to the production well and/or by increasing the permeability of the formation adjacent to the production well by formation of macro and/or micro fractures.

[0058] In some embodiments, the heat source in production well 106 allows for vapor phase removal of formation fluids from the formation. Providing heating at or through the production well may: (1) inhibit condensation and/or refluxing of production fluid when such production fluid is moving in the production well proximate the overburden, (2) increase heat input into the formation, (3) increase production rate from the production well as compared to a production well without a heat source, (4) inhibit condensation of high carbon number compounds (C_6 hydrocarbons and above) in the production well, and/or (5) increase formation permeability at or proximate the production well.

[0059] Subsurface pressure in the formation may correspond to the fluid pressure generated in the formation. As temperatures in the heated portion of the formation increase, the pressure in the heated portion may increase as a result of thermal expansion of in situ fluids, increased fluid generation and vaporization of water. Controlling rate of fluid removal from the formation may allow for control of pressure in the formation. Pressure in the formation may be determined at a number of different locations, such as near or at production wells, near or at heat sources, or at monitor wells.

[0060] In some hydrocarbon containing formations, production of hydrocarbons from the formation is inhibited until at least some hydrocarbons in the formation have been mobilized and/or pyrolyzed. Formation fluid may be produced from the formation when the formation fluid is of a selected quality. In some embodiments, the selected quality includes an API gravity of at least about 20°, 30°, or 40°. Inhibiting production until at least some hydrocarbons are mobilized and/or pyrolyzed may increase conversion of heavy hydrocarbons to light hydrocarbons. Inhibiting initial production may minimize the production of heavy hydrocarbons from the formation. Production of substantial amounts of heavy hydrocarbons may require expensive equipment and/or reduce the life of production equipment.

[0061] In some embodiments, pressure generated by expansion of mobilized fluids, pyrolysis fluids or other fluids generated in the formation may be allowed to increase although an open path to production wells 106 or any other pressure sink may not yet exist in the formation. The fluid pressure may be allowed to increase towards a lithostatic pressure. Fractures in the hydrocarbon containing formation may form when the fluid approaches the lithostatic pressure. For example, fractures may form from heat sources 102 to production wells 106 in the heated portion of the formation. The generation of fractures in the heated portion may relieve some of the pressure in the portion. Pressure in the formation may have to be maintained below a selected pressure to inhibit unwanted production, fracturing of the overburden or underburden, and/or coking of hydrocarbons in the formation.

[0062] After mobilization and/or pyrolysis temperatures are reached and production from the formation is allowed, pressure in the formation may be varied to alter and/or control a composition of formation fluid produced, to control a percentage of condensable fluid as compared to non-condensable fluid in the formation fluid, and/or to control an API gravity of formation fluid being produced. For example, decreasing pressure may result in production of a larger condensable fluid component. The condensable fluid component may contain a larger percentage of olefins.

[0063] In some in situ heat treatment process embodiments, pressure in the formation may be maintained high enough to promote production of formation fluid with an API gravity of greater than 20°. Maintaining increased pressure in the formation may inhibit formation subsidence during in situ heat treatment. Maintaining increased pressure may reduce or

eliminate the need to compress formation fluids at the surface to transport the fluids in collection conduits to treatment facilities.

5 [0064] Maintaining increased pressure in a heated portion of the formation may surprisingly allow for production of large quantities of hydrocarbons of increased quality and of relatively low molecular weight. Pressure may be maintained so that formation fluid produced has a minimal amount of compounds above a selected carbon number. The selected carbon number may be at most 25, at most 20, at most 12, or at most 8. Some high carbon number compounds may be entrained in vapor in the formation and may be removed from the formation with the vapor. Maintaining increased pressure in the formation may inhibit entrainment of high carbon number compounds and/or multi-ring hydrocarbon compounds in the vapor. High carbon number compounds and/or multi-ring hydrocarbon compounds may remain in a liquid phase in the formation for significant time periods. The significant time periods may provide sufficient time for the compounds to pyrolyze to form lower carbon number compounds.

15 [0065] Formation fluid produced from production wells 106 may be transported through collection piping 108 to treatment facilities 110. Formation fluids may also be produced from heat sources 102. For example, fluid may be produced from heat sources 102 to control pressure in the formation adjacent to the heat sources. Fluid produced from heat sources 102 may be transported through tubing or piping to collection piping 108 or the produced fluid may be transported through tubing or piping directly to treatment facilities 20 110. Treatment facilities 110 may include separation units, reaction units, upgrading units, fuel cells, turbines, storage vessels, and/or other systems and units for processing produced formation fluids. The treatment facilities may form transportation fuel from at least a portion of the hydrocarbons produced from the formation. In some embodiments, the transportation fuel may be jet fuel, such as JP-8.

25 [0066] In certain embodiments, heat sources, heat source power sources, production equipment, supply lines, and/or heat source or production support equipment are positioned in tunnels to enable smaller sized heat sources and/or smaller sized equipment to be used to treat the formation. Positioning such equipment and/or structures in tunnels may also reduce energy costs for treating the formation, reduce emissions from the treatment process, facilitate heating system installation, and/or reduce heat loss to the overburden as compared to hydrocarbon recovery processes that utilize surface based equipment.

30

[0067] Heat sources with electrically conducting material may allow current flow through a formation from one heat source to another heat source. Current flow between the heat sources with electrically conducting material may heat the formation to increase permeability in the formation and/or lower viscosity of hydrocarbons in the formation.

5 Heating using current flow or “joule heating” through the formation may heat portions of the hydrocarbon layer in a shorter amount of time relative to heating the hydrocarbon layer using conductive heating between heaters spaced apart in the formation.

[0068] In some embodiments, heat sources that include electrically conductive materials are positioned in a hydrocarbon layer. Portions of the hydrocarbon layer may be heated
10 from current generated from the heat sources that flows from the heat sources and through the layer. Positioning of electrically conductive heat sources in a hydrocarbon layer at depths sufficient to minimize loss of conductive solutions may allow hydrocarbons layers to be heated at relatively high temperatures over a period of time with minimal loss of water and/or conductive solutions.

15 [0069] FIGS. 2-6 depict schematics of embodiments for treating a subsurface formation using heat sources having electrically conductive material. FIG. 2 depicts first conduit 200 and second conduit 202 positioned in wellbores 204, 204' in hydrocarbon layer 206. In certain embodiments, first conduit 200 and/or second conduit 202 are conductors (for example, exposed metal or bare metal conductors). In some embodiments, conduits 200,
20 202 are oriented substantially horizontally or at an incline in the formation. Conduits 200, 202 may be positioned in or near a bottom portion of hydrocarbon layer 206.

[0070] Wellbores 204, 204' may be open wellbores. In some embodiments, the conduits extend from a portion of the wellbore. In some embodiments, the vertical or overburden portions of wellbores 204, 204' are cemented with non-conductive cement or foam cement.
25 Wellbores 204, 204' may include packers 208 and/or electrical insulators 210. In some embodiments, packers 208 are not necessary. Electrical insulators 210 may insulate conduits 200, 202 from casing 212.

[0071] In some embodiments, the portion of casing 212 adjacent to overburden 214 is made of material that inhibits ferromagnetic effects. The casing in the overburden may be
30 made of fiberglass, polymers, and/or a non-ferromagnetic metal (for example, a high manganese steel). Inhibiting ferromagnetic effects in the portion of casing 212 adjacent to overburden 214 may reduce heat losses to the overburden and/or electrical losses in the overburden. In some embodiments, overburden casings 212 include non-metallic materials

such as fiberglass, polyvinylchloride (PVC), chlorinated polyvinylchloride (CPVC), high-density polyethylene (HDPE), and/or non-ferromagnetic metals (for example, non-ferromagnetic high manganese steels). HDPEs with working temperatures in a range for use in overburden 214 include HDPEs available from Dow Chemical Co., Inc (Midland, Michigan, U.S.A.). In some embodiments, casing 212 includes carbon steel coupled on the inside and/or outside diameter of a non-ferromagnetic metal (for example, carbon steel clad with copper or aluminum) to inhibit ferromagnetic effects or inductive effects in the carbon steel. Other non-ferromagnetic metals include, but are not limited to, manganese steels with at least 15% by weight manganese, 0.7% by weight carbon, 2% by weight chromium, iron aluminum alloys with at least 18% by weight aluminum, and austenitic stainless steels such as 304 stainless steel or 316 stainless steel.

[0072] Portions or all of conduits 200, 202 may include electrically conductive material 216. Electrically conductive materials include, but are not limited to, thick walled copper, heat treated copper (“hardened copper”), carbon steel clad with copper, aluminum, or aluminum or copper clad with stainless steel. Conduits 200, 202 may have dimensions and characteristics that enable the conduits to be used later as injection wells and/or production wells. Conduit 200 and/or conduit 202 may include perforations or openings 218 to allow fluid to flow into or out of the conduits. In some embodiments, portions of conduit 200 and/or conduit 202 are pre-perforated with coverings initially placed over the perforations and removed later. In some embodiments, conduit 200 and/or conduit 202 include slotted liners.

[0073] After a desired time (for example, after injectivity has been established in the layer), the coverings of the perforations may be removed or slots may be opened to open portions of conduit 200 and/or conduit 202 to convert the conduits to production wells and/or injection wells. In some embodiments, coverings are removed by inserting an expandable mandrel in the conduits to remove coverings and/or open slots. In some embodiments, heat is used to degrade material placed in the openings in conduit 200 and/or conduit 202. After degradation, fluid may flow into or out of conduit 200 and/or conduit 202.

[0074] Power to electrically conductive material 216 may be supplied from one or more surface power supplies through conductors 220, 220'. Conductors 220, 220' may be cables supported on a tubular or other support member. In some embodiments, conductors 220, 220' are conduits through which electricity flows to conduit 200 or conduit 202. Electrical

connectors 222 may be used to electrically couple conductors 220, 220' to conduits 200, 202. Conductor 220 and conductor 220' may be coupled to the same power supply to form an electrical circuit. Sections of casing 212 (for example a section between packers 208 and electrical connectors 222) may include or be made of insulating material (such as
5 enamel coating) to prevent leakage of electrical current towards the surface of the formation.

[0075] In some embodiments, a direct current power source is supplied to either first conduit 200 or second conduit 202. In some embodiments, time varying current is supplied to first conduit 200 and/or second conduit 202. Current flowing from conductors 220, 220'
10 to conduits 200, 202 may be low frequency current (for example, about 50 Hz, about 60 Hz, or frequencies up to about 1000 Hz). A voltage differential between the first conduit 200 and second conduit 202 may range from about 100 volts to about 1200 volts, from about 200 volts to about 1000 volts, or from about 500 volts to 700 volts. In some embodiments, higher frequency current and/or higher voltage differentials may be utilized.
15 Use of time varying current may allow longer conduits to be positioned in the formation. Use of longer conduits allows more of the formation to be heated at one time and may decrease overall operating expenses. Current flowing to first conduit 200 may flow through hydrocarbon layer 206 to second conduit 202, and back to the power supply. Flow of current through hydrocarbon layer 206 may cause resistance heating of the hydrocarbon
20 layer.

[0076] During the heating process, current flow in conduits 200, 202 may be measured at the surface. Measuring of the current entering conduits 200, 202 may be used to monitor the progress of the heating process. Current between conduits 200, 202 may increase steadily until a predetermined upper limit (I_{max}) is reached. In some embodiments,
25 vaporization of water occurs at the conduits, at which time a drop in current is observed. Current flow of the system is indicated by arrows 224. Current flow in hydrocarbon containing layer 206 between conduits 200, 202 heats the hydrocarbon layer between and around the conduits. Conduits 200, 202 may be part of a pattern of conduits in the formation that provide multiple pathways between wells so that a large portion of layer 206
30 is heated. The pattern may be a regular pattern, (for example, a triangular or rectangular pattern) or an irregular pattern.

[0077] FIG. 3 depicts a schematic of an embodiment of a system for treating a subsurface formation using electrically conductive material. Conduit 226 and ground 228 may extend

from wellbores 204, 204' into hydrocarbon layer 206. Ground 228 may be a rod or a conduit positioned in hydrocarbon layer 206 between about 5 m and about 30 m away from conduit 226 (for example, about 10 m, about 15 m, or about 20 m). In some embodiments, electrical insulators 210' electrically isolate ground 228 from casing 212' and/or conduit
5 section 230 positioned in wellbore 204'. As shown, ground 228 is a conduit that includes openings 218.

[0078] Conduit 226 may include sections 232, 234 of conductive material 216. Sections 232, 234 may be separated by electrically insulating material 236. Electrically insulating material 236 may include polymers and/or one or more ceramic isolators. Section 232 may
10 be electrically coupled to the power supply by conductor 220. Section 234 may be electrically coupled to the power supply by conductor 220'. Electrical insulators 210 may separate conductor 220 from conductor 220'. Electrically insulating material 236 may have dimensions and insulating properties sufficient to inhibit current from section 232
15 flowing across insulation material 236 to section 234. For example, a length of electrically insulating material 236 may be about 30 meters, about 35 meters, about 40 meters, or greater. Using a conduit that has electrically conductive sections 232, 234 may allow fewer wellbores to be drilled in the formation. Conduits having electrically conductive
20 sections ("segmented heat sources") may allow longer conduit lengths. In some embodiments, segmented heat sources allow injection wells used for drive processes (for example, steam assisted gravity drainage and/or cyclic steam drive processes) to be spaced further apart, and thus achieve an overall higher recovery efficiency.

[0079] Current provided through conductor 220 may flow to conductive section 232 through hydrocarbon layer 206 to a section of ground 228 opposite section 232. The electrical current may flow along ground 228 to a section of the ground opposite section
25 234. The current may flow through hydrocarbon layer 206 to section 234 and through conductor 220' back to the power circuit to complete the electrical circuit. Electrical connector 238 may electrically couple section 234 to conductor 220'. Current flow is indicated by arrows 224. Current flow through hydrocarbon layer 206 may heat the hydrocarbon layer to create fluid injectivity in the layer, mobilize hydrocarbons in the
30 layer, and/or pyrolyze hydrocarbons in the layer. When using segmented heat sources, the amount of current required for the initial heating of the hydrocarbon layer may be at least 50% less than current required for heating using two non-segmented heat sources or two electrodes. Hydrocarbons may be produced from hydrocarbon layer 206 and/or other

sections of the formation using production wells. In some embodiments, one or more portions of conduit 226 is positioned in a shale layer and ground 228 is positioned in hydrocarbon layer 206. Current flow through conductors 220, 220' in opposite directions may allow for cancellation of at least a portion of the magnetic fields due to the current flow. Cancellation of at least a portion of the magnetic fields may inhibit induction effects in the overburden portion of conduit 226 and the wellhead of wellbore 204.

5 [0080] FIG. 4 depicts an embodiment in which first conduit 226 and second conduit 226' are used for heating hydrocarbon layer 206. Electrically insulating material 236 may separate sections 232, 234 of first conduit 226. Electrically insulating material 236' may separate sections 232', 234' of second conduit 226'.

[0081] Current may flow from a power source through conductor 220 of first conduit 226 to section 232. The current may flow through hydrocarbon containing layer 206 to section 234' of second conduit 226'. The current may return to the power source through conductor 220' of second conduit 226'. Similarly, current may flow through conductor 15 220 of second conduit 226' to section 232', through hydrocarbon layer 206 to section 234 of first conduit 226, and the current may return to the power source through conductor 220' of the first conduit 226. Current flow is indicated by arrows 224. Generation of current flow from electrically conductive sections of conduits 226, 226' may heat portions of hydrocarbon layer 206 between the conduits and create fluid injectivity in the layer, mobilize hydrocarbons in the layer, and/or pyrolyze hydrocarbons in the layer. In some 20 embodiments, one or more portions of conduits 226, 226' are positioned in shale layers.

[0082] By creating opposite current flow through the wellbores, as described with reference to FIGS. 3 and 4, magnetic fields in the overburden may cancel out. Cancellation of the magnetic fields in the overburden may allow ferromagnetic materials to be used in 25 overburden casings 212. Using ferromagnetic casings in the wellbores may be less expensive and/or easier to install than non-ferromagnetic casings (such as fiberglass casings).

[0083] In some embodiments, two or more conduits may branch from a common wellbore. FIG. 5 depicts a schematic of an embodiment of two conduits extending from one common 30 wellbore. Extending the conduits from one common wellbore may reduce costs by forming fewer wellbores in the formation. Using common wellbores may allow wellbores to be spaced further apart and produce the same heating efficiencies and the same heating times as drilling two different wellbores for each conduit through the formation. Using

common wellbores may allow ferromagnetic materials to be used in overburden casing 212 since the magnetic fields cancel due to the approximately equal and opposite flow of current in the overburden section of conduits 200, 202. Extending conduits from one common wellbore may allow longer conduits to be used.

5 **[0084]** Conduits 200, 202 may extend from common vertical portion 240 of wellbore 204. Conduit 202 may be installed through an opening (for example, a milled window) in vertical portion 240. Conduits 200, 202 may extend substantially horizontally or inclined from vertical portion 240. Conduits 200, 202 may include electrically conductive material 216. In some embodiments, conduits 200, 202 include electrically conductive sections and
10 electrically insulating material, as described for conduit 226 in FIGS. 3 and 4. Conduit 200 and/or conduit 202 may include openings 218. Current may flow from a power source to conduit 200 through conductor 220. The current may pass through hydrocarbon containing layer 206 to conduit 202. The current may pass from conduit 202 through conductor 220' back to the power source to complete the circuit. The flow of current as shown by arrows
15 224 through hydrocarbon layer 206 from conduits 200, 202 heats the hydrocarbon layer between the conduits.

[0085] In some embodiments, a subsurface formation is heated using heating systems described in the embodiments depicted in FIGS. 2, 3, 4, and/or 5 to heat fluids in hydrocarbon layer 206 to mobilization, visbreaking, and/or pyrolyzation temperatures.
20 Such heated fluids may be produced from the hydrocarbon layer and/or from other sections of the formation. As the hydrocarbon layer 206 is heated, the conductivity of the heated portion of the hydrocarbon layer increases. For example, conductivity of hydrocarbon layers close to the surface may increase by as much as a factor of three when the temperature of the formation increases from 20 °C to 100 °C. For deeper layers, where the
25 water vaporization temperature is higher due to increased fluid pressure, the increase in conductivity may be greater. Greater increases in conductivity may increase the heating rate of the formation. Thus, as the conductivity increases in the formation, increases in heating may be more concentrated in deeper layers.

[0086] As a result of heating, the viscosity of heavy hydrocarbons in a hydrocarbon layer
30 is reduced. Reducing the viscosity may create more injectivity in the layer and/or mobilize hydrocarbons in the layer. As a result of being able to rapidly heat the hydrocarbon layer using heating systems described in the embodiments depicted in FIGS. 2, 3, 4, and/or 5, sufficient fluid injectivity in the hydrocarbon layer may be achieved more quickly, for

example, in about two years. In some embodiments, these heating systems are used to create drainage paths between the heat sources and production wells for a drive and/or a mobilization process. In some embodiments, these heating systems are used to provide heat during the drive process. The amount of heat provided by the heating systems may be small compared to the heat input from the drive process (for example, the heat input from steam injection).

[0087] Once sufficient fluid injectivity has been established, a drive fluid, a pressuring fluid, and/or a solvation fluid may be injected in the heated portion of hydrocarbon layer 206. In some embodiments (for example, the embodiments depicted in FIGS. 2 and 5), conduit 202 is perforated and fluid is injected through the conduit to mobilize and/or further heat hydrocarbon layer 206. Fluids may drain and/or be mobilized towards conduit 200. Conduit 200 may be perforated at the same time as conduit 202 or perforated at the start of production. Formation fluids may be produced through conduit 200 and/or other sections of the formation.

[0088] As shown in FIG. 6, conduit 200 is positioned in layer 242 located between hydrocarbon layers 206A and 206B. Conduit 202 is positioned in hydrocarbon layer 206A. Conduits 200, 202, shown in FIG. 6, may be any of conduits 200, 202, depicted in FIGS. 2 and/or 5, as well as conduits 226, 226' or ground 228, depicted in FIGS. 3 and 4. In some embodiments, portions of conduit 200 are positioned in hydrocarbon layers 206A or 206B and in layer 242.

[0089] Layer 242 may be a conductive layer, water/sand layer, or hydrocarbon layer that has different porosity than hydrocarbon layer 206A and/or hydrocarbon layer 206B. In some embodiments, layer 242 is a shale layer. Layer 242 may have conductivities ranging from about 0.2 mho/m to about 0.5 mho/m. Hydrocarbon layers 206A and/or 206B may have conductivities ranging from about 0.02 mho/m to about 0.05 mho/m. Conductivity ratios between layer 242 and hydrocarbon layers 206A and/or 206B may range from about 10:1, about 20:1, or about 100:1. When layer 242 is a shale layer, heating the layer may desiccate the shale layer and increase the permeability of the shale layer to allow fluid to flow through the shale layer. The increased permeability in the shale layer allows mobilized hydrocarbons to flow from hydrocarbon layer 206A to hydrocarbon layer 206B, allows drive fluids to be injected in hydrocarbon layer 206A, and/or allows steam drive processes (for example, SAGD, cyclic steam soak (CSS), sequential CSS and SAGD or steam flood, or simultaneous SAGD and CSS) to be performed in hydrocarbon layer 206A.

[0090] In some embodiments, a conductive layer is selected to provide lateral continuity of conductivity within the conductive layer and to provide a substantially higher conductivity, for a given thickness, than the surrounding hydrocarbon layers. Thin conductive layers selected on this basis may substantially confine the heat generation within and around the
5 conductive layers and allow much greater spacing between rows of electrodes. In some embodiments, layers to be heated are selected, on the basis of resistivity well logs, to provide lateral continuity of conductivity.

[0091] Once sufficient fluid injectivity is created, fluid may be injected in layer 242 through an injection well and/or conduit 200 to heat or mobilize fluids in hydrocarbon
10 layer 206B. Fluids may be produced from hydrocarbon layer 206B and/or other sections of the formation. In some embodiments, fluid is injected in conduit 202 to mobilize and/or heat in hydrocarbon layer 206A. Heated and/or mobilized fluids may be produced from conduit 200 and/or other production wells located in hydrocarbon layer 206B and/or other sections of the formation.

[0092] In certain embodiments, a solvation fluid, in combination with a pressurizing fluid, is used to treat the hydrocarbon formation in addition to the in situ heat treatment process. In some embodiments, the solvation fluid, in combination with the pressurizing fluid, is used after the hydrocarbon formation has been treated using a drive process. In some
15 embodiments, solvation fluids are foamed or made into foams to improve the efficiency of the drive process. Since an effective viscosity of the foam may be greater than the
20 viscosity of the individual components, the use of a foaming composition may improve the sweep efficiency of the drive fluid.

[0093] In some embodiments, the solvation fluid includes a foaming composition. The foaming composition may be injected simultaneously or alternately with the pressurizing
25 fluid and/or the drive fluid to form foam in the heated section. Use of foaming compositions may be more advantageous than use of polymer solutions since foaming compositions are thermally stable at temperatures up to 600 °C while polymer compositions may degrade at temperatures above 150 °C. Use of foaming compositions at temperatures above about 150 °C may allow more hydrocarbon fluids and/or more efficient
30 removal of hydrocarbons from the formation as compared to use of polymer compositions.

[0094] Foaming compositions may include, but are not limited to, surfactants. In certain embodiments, the foaming composition includes a polymer, a surfactant, an inorganic base, water, steam, and/or brine. The inorganic base may include, but is not limited to, sodium

hydroxide, potassium hydroxide, potassium carbonate, potassium bicarbonate, sodium carbonate, sodium bicarbonate, or mixtures thereof. Polymers include polymers soluble in water or brine such as, but not limited to, ethylene oxide or propylene oxide polymers.

[0095] Surfactants include ionic surfactants and/or nonionic surfactants. Examples of ionic surfactants include alpha-olefinic sulfonates, alkyl sodium sulfonates, and sodium alkyl benzene sulfonates. Non-ionic surfactants include, for example, triethanolamine. Surfactants capable of forming foams include, but are not limited to, alpha-olefinic sulfonates, alkylpolyalkoxyalkylene sulfonates, aromatic sulfonates, alkyl aromatic sulfonates, alcohol ethoxy glycerol sulfonates (AEGS), or mixtures thereof. Non-limiting examples of surfactants capable of being foamed include AEGS 25-12 surfactant, sodium dodecyl 3EO sulfate, and sulfates made from branched alcohols made using the Guerbet method such as, for example, sodium dodecyl (Guerbert) 3PO sulfate⁶³, ammonium isotridecyl(Guerbert) 4PO sulfate⁶³, sodium tetradecyl (Guerbert) 4PO sulfate⁶³. Nonionic and ionic surfactants and/or methods of use and/or methods of foaming for treating a hydrocarbon formation are described in U.S. Patent Nos. 4,643,256 to Dilgren et al.; 5,193,618 to Loh et al.; 5,046,560 to Teletzke et al.; 5,358,045 to Sevigny et al.; 6,439,308 to Wang; 7,055,602 to Shpakoff et al.; 7,137,447 to Shpakoff et al.; 7,229,950 to Shpakoff et al.; and 7,262,153 to Shpakoff et al.; and by Wellington et al, in "Surfactant-Induced Mobility Control for Carbon Dioxide Studied with Computerized Tomography," American Chemical Society Symposium Series No. 373, 1988.

[0100] Foam may be formed in the formation by injecting the foaming composition during or after addition of steam. Pressurizing fluid (for example, carbon dioxide, methane, and/or nitrogen) may be injected in the formation before, during, or after the foaming composition is injected. A type of pressurizing fluid may be based on the surfactant used in the foaming composition. For example, carbon dioxide may be used with alcohol ethoxy glycerol sulfonates. The pressurizing fluid and foaming composition may mix in the formation and produce foam. In some embodiments, non-condensable gas is mixed with the foaming composition prior to injection to form a pre-foamed composition. The foaming composition, the pressurizing fluid, and/or the pre-foamed composition may be periodically injected in the heated formation. The foaming composition, pre-foamed compositions, drive fluids, and/or pressurizing fluids may be injected at a pressure sufficient to displace the formation fluids without fracturing the reservoir.

63293-4304

[0101] Further modifications and alternative embodiments of various aspects of the invention may be apparent to those skilled in the art in view of this description. Accordingly, this description is to be construed as illustrative only and is for the purpose of teaching those skilled in the art the general manner of carrying out the invention. It is to be understood that the forms of the invention shown and described herein are to be taken as
5 the presently preferred embodiments. Elements and materials may be substituted for those illustrated and described herein, parts and processes may be reversed, and certain features of the invention may be utilized independently, all as would be apparent to one skilled in the art after having the benefit of this description of the invention. Changes may be made
10 in the elements described herein without departing from the scope of the invention as described in the following claims. In addition, it is to be understood that features described herein independently may, in certain embodiments, be combined.

63293-4304

CLAIMS:

1. A system for treating a subsurface formation, comprising:
a wellbore at least partially located in a hydrocarbon containing formation, the wellbore comprising a substantially vertical portion and at least two substantially horizontal
5 or inclined portions coupled to the vertical portion;
a first conductor at least partially positioned in a first of the two substantially horizontal or inclined portions of the wellbore, wherein the first conductor comprises electrically conductive materials;
a second conductor at least partially positioned in a second of the two
10 substantially horizontal or inclined portions of the wellbore, wherein the second conductor comprises electrically conductive materials; and
a power supply coupled to at least the first conductor, the power supply configured to electrically excite the electrically conductive materials of the first conductor such that electrical current flows from the electrically conductive materials in the first
15 conductor, through at least a portion of the formation, to the second conductor and heats at least a portion of the formation between the two substantially horizontal or inclined portions of the wellbore.
2. The system of claim 1, wherein the second conductor is a ground conductor.
3. The system of claim 1, wherein an average distance between the conductive
20 portions of the first conductor and the second conductor is at least 10 meters.
4. The system of claim 1, wherein the first conductor comprises a conduit or a perforated conduit.
5. The system of claim 1, wherein the second conductor comprises a perforated conduit.

63293-4304

6. The system of claim 1, wherein at least one of the conductors comprises a first layer comprising carbon steel and a second layer comprising copper, and at least a portion of the second layer substantially surrounds or partially surrounds a portion of the first layer.
7. The system of claim 1, wherein at least one of the conductors comprises an
5 overburden section and the overburden section comprises one or more ferromagnetic materials.
8. The system of claim 1, wherein at least one of the conductors is located in a wellbore comprising one or more electrical insulators.
9. The system of claim 1, wherein at least one of the conductors comprises a
10 perforated conduit, the system further comprising a fluid injection system configured to inject fluid through at least some of the perforations and into the formation.
10. A method for treating a subsurface formation, comprising:
- providing a wellbore at least partially located in the formation, the wellbore comprising a substantially vertical portion and at least two substantially horizontal or inclined
15 portions coupled to the vertical portion;
- providing a first conductor at least partially positioned in a first of the two substantially horizontal or inclined portions of the wellbore, wherein the first conductor comprises electrically conductive materials;
- providing a second conductor at least partially positioned in a second of the
20 two substantially horizontal or inclined portions of the wellbore, wherein the first conductor comprises electrically conductive materials; and
- providing electrical current to the first conductor to electrically excite the electrically conductive materials of the first conductor such that electrical current flows from the electrically conductive materials in the first conductor, through at least a portion of the
25 formation, to the electrically conductive materials in the second conductor to heat at least a

63293-4304

portion of the formation between the two substantially horizontal or inclined portions of the wellbore.

11. The method of claim 10, wherein the first conductor extends from the vertical portion of the common wellbore, wherein at least a portion of the first conductor extends
5 horizontally or inclined from the vertical portion.
12. The method of claim 10, wherein the second conductor extends from the vertical portion of the common wellbore, wherein at least a portion of the second conductor is substantially parallel to the first conductor.
13. The method of claim 10, further comprising creating increased fluid injectivity
10 in at least portion of the section between the first conductor and the second conductor.
14. The method of claim 10, further comprising perforating at least a portion of the first conductor and/or the second conductor.
15. The method of claim 10, further comprising mobilizing at least some hydrocarbons in the formation with the generated heat.
- 15 16. The method of claim 15, further comprising producing at least a portion of mobilized formation fluids from the formation.
17. The method of claim 10, further comprising injecting a foaming composition, and injecting a pressurizing fluid at a rate sufficient to foam the foaming composition in the section.
- 20 18. The method of claim 10, further comprising injecting a pre-foamed composition.
19. The method of claim 10, further comprising providing at least a portion of the first conductor to a shale layer of the formation.

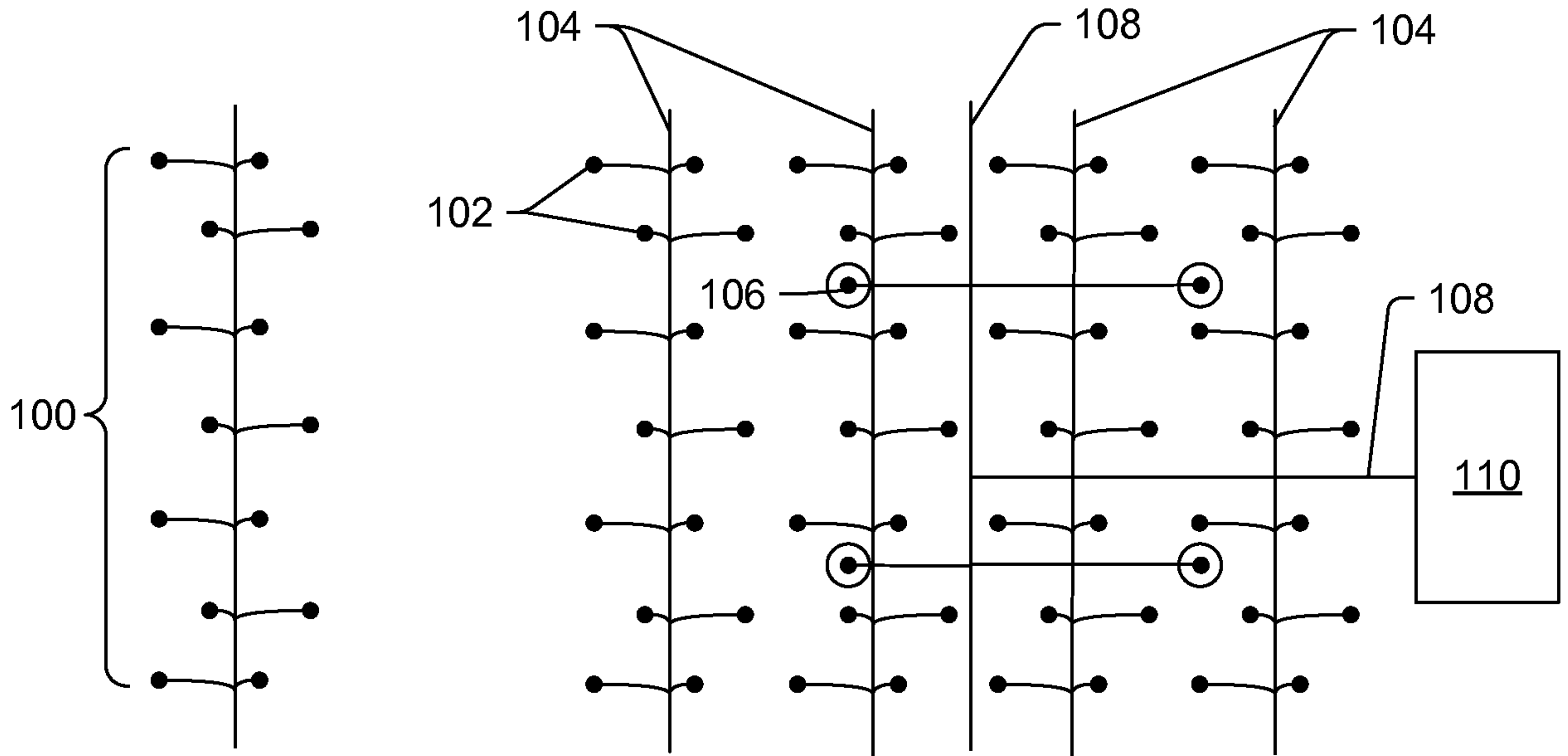

FIG. 1

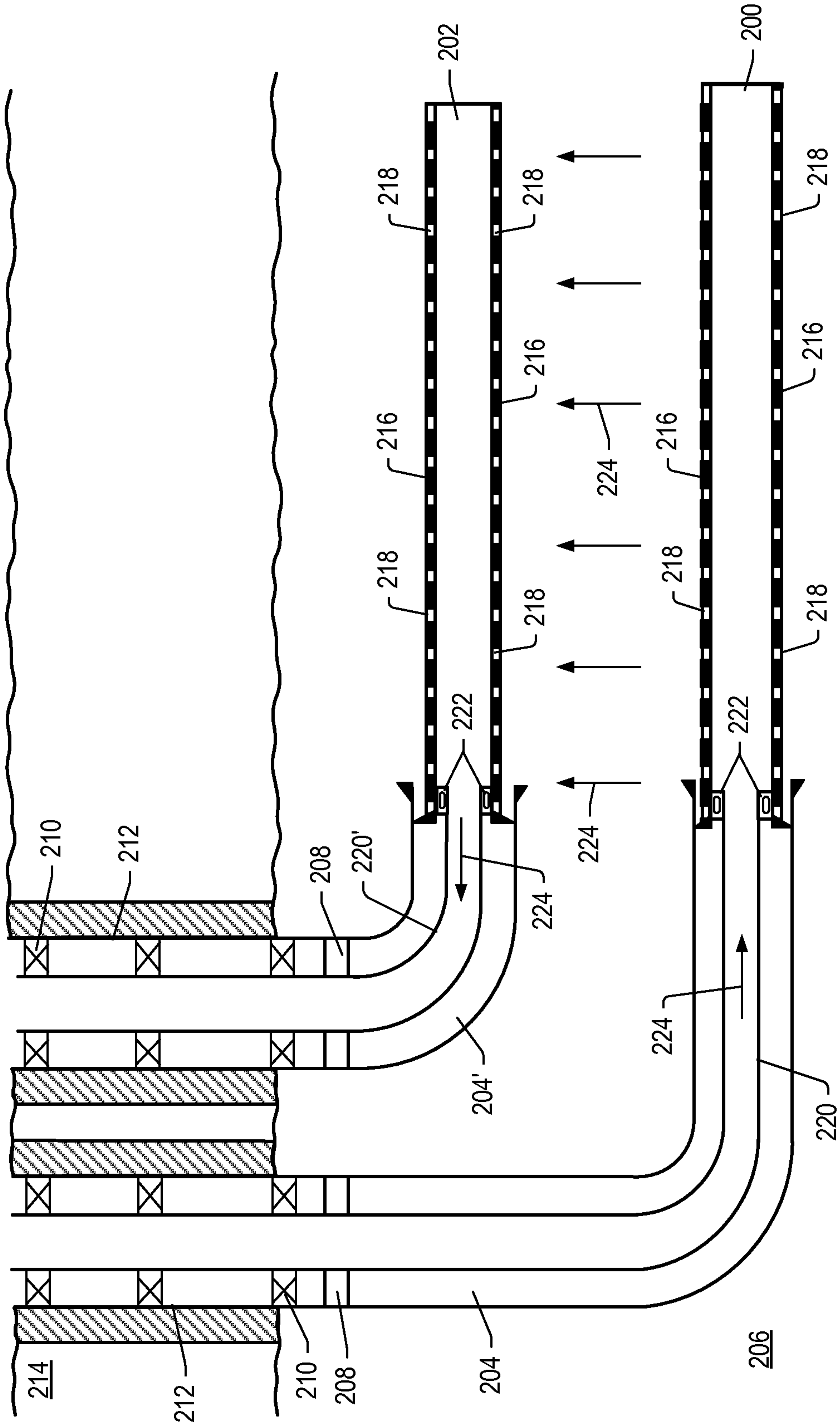

FIG. 2

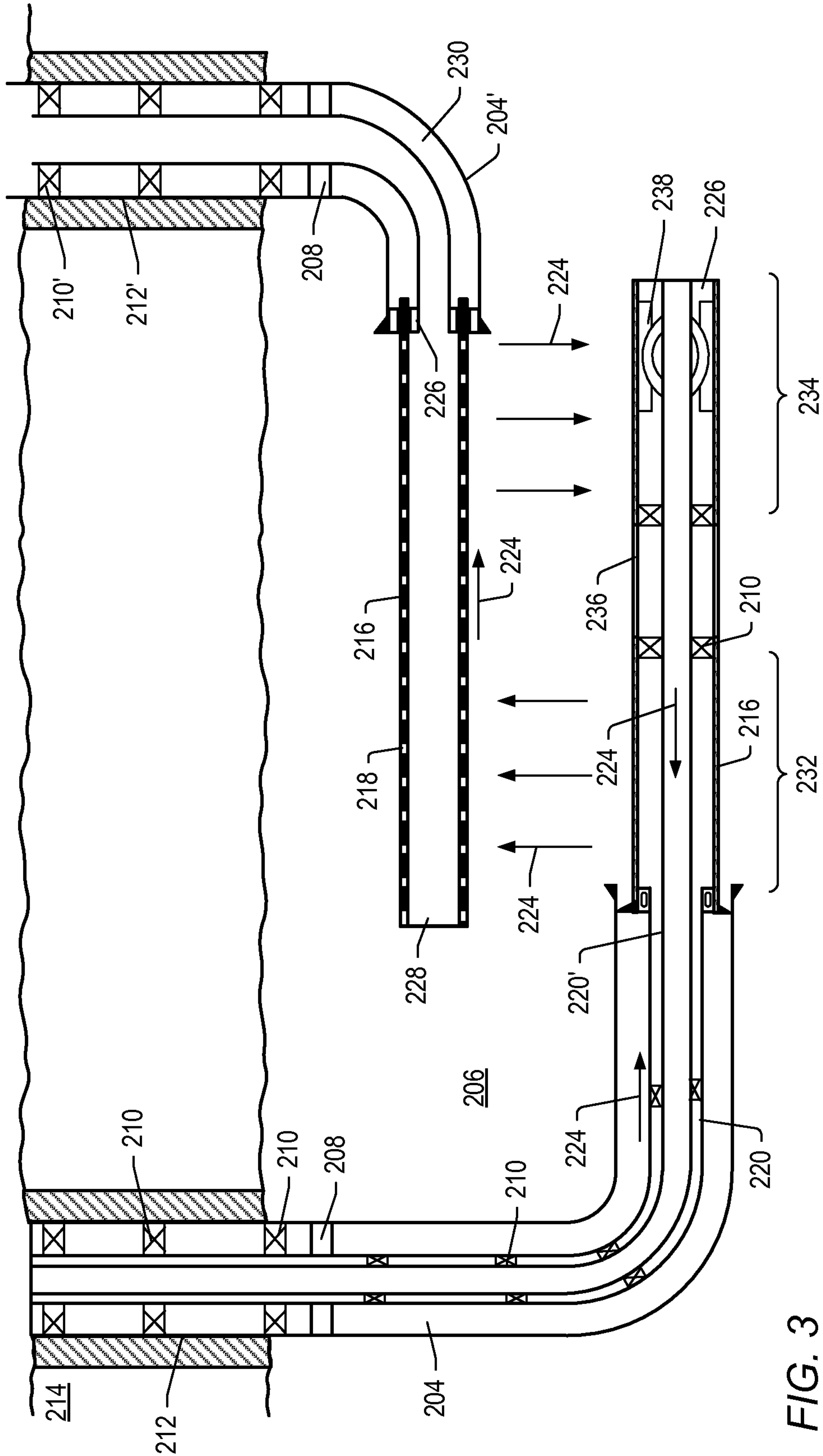

FIG. 3

4 / 6

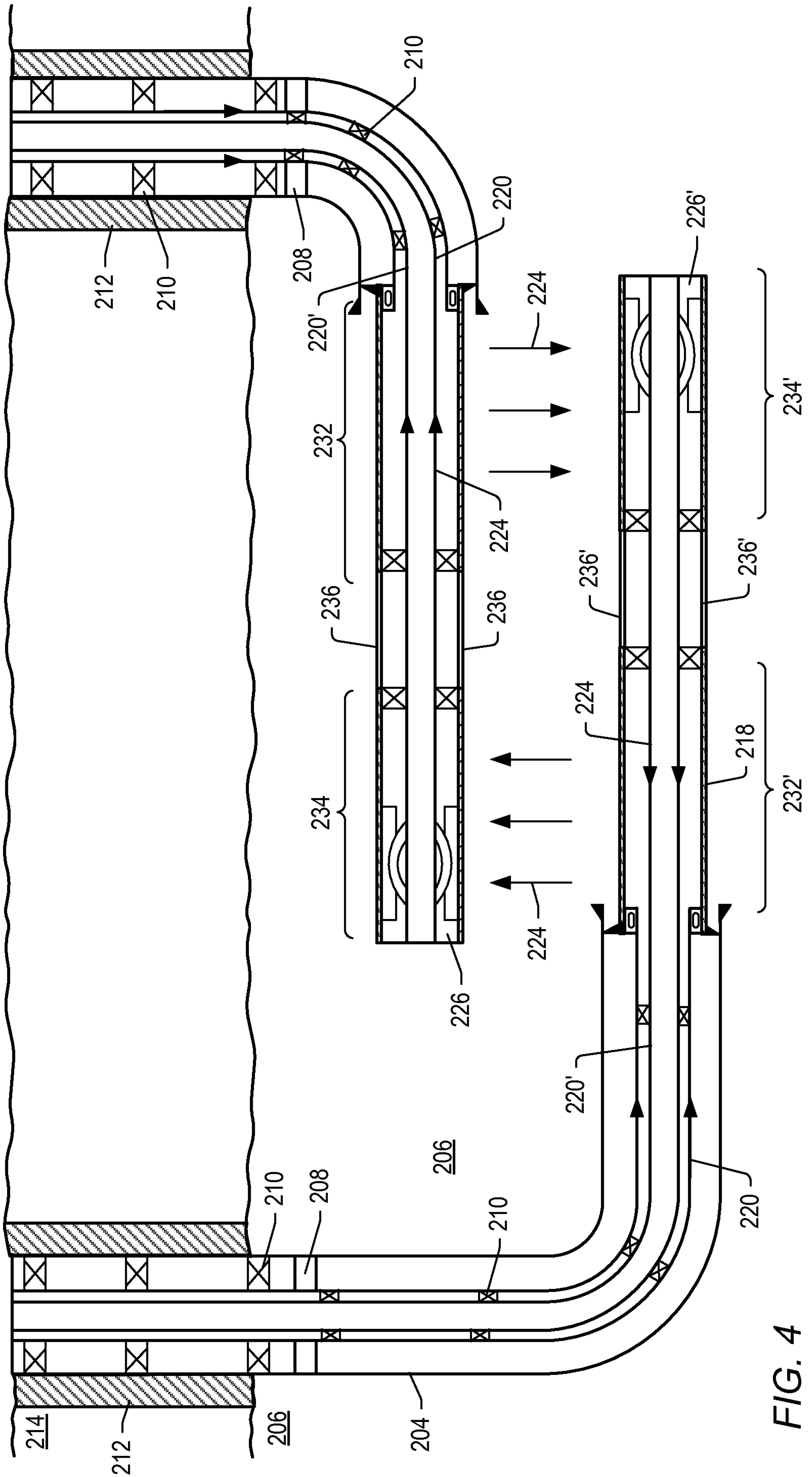

FIG. 4

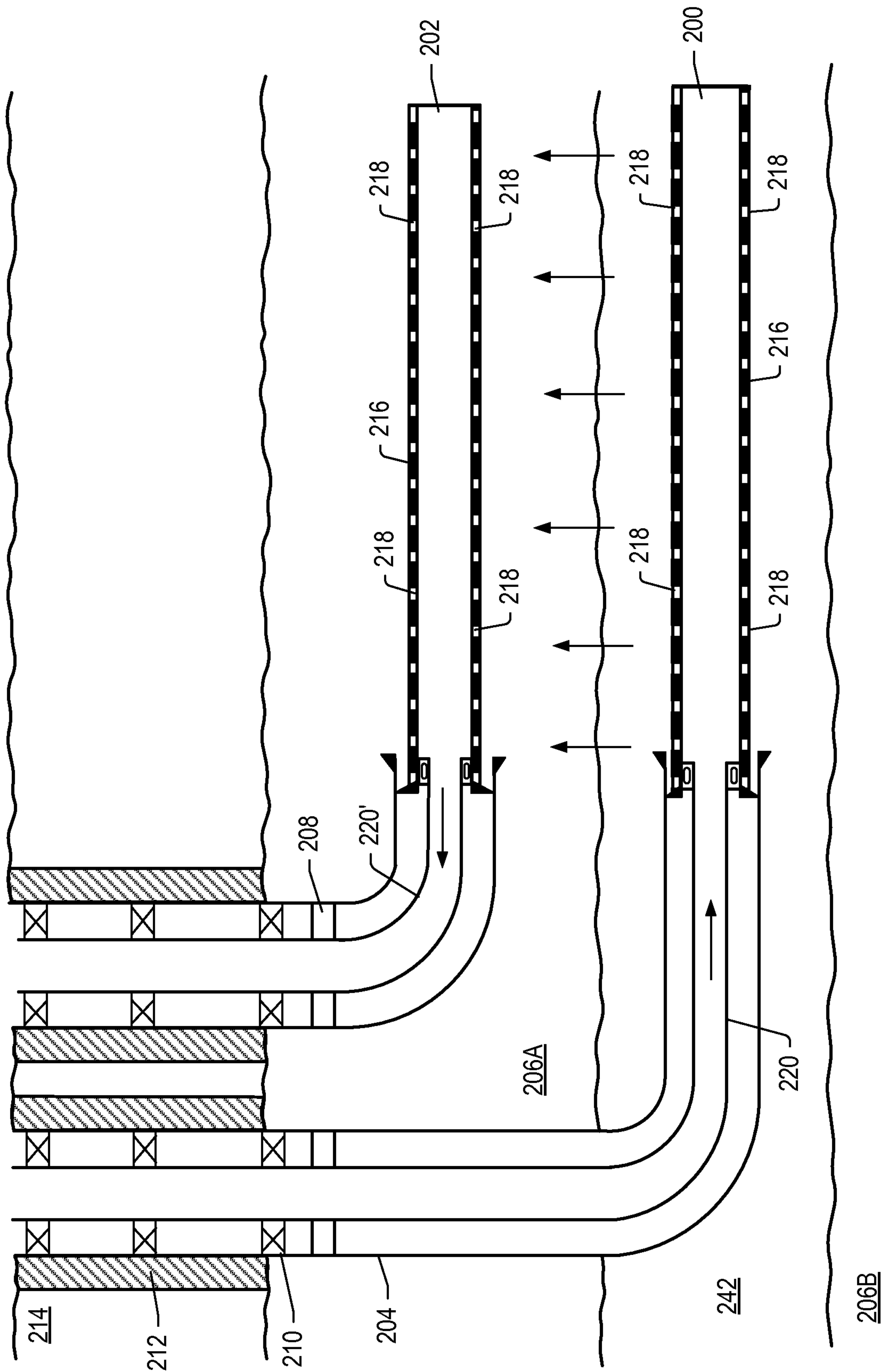

FIG. 6

