

1

, , 가 가
 , , 가

, , 가 가 (jamming)
 , , 가 가
 (가)가
 , , 가 가
 , , 가 가

(着脫)
 가

, , 가 가
 , , 가 가
 , , 가 가
 가 가
 가 가

, , 가 가
 가 , 가 가
 , , 가 가
 , , 가 가
 , , 가 가

, , 가 가
 가 가

, , 가 가
 , , 가 가
 , , 가 가
 가 (buckling)
 가 가

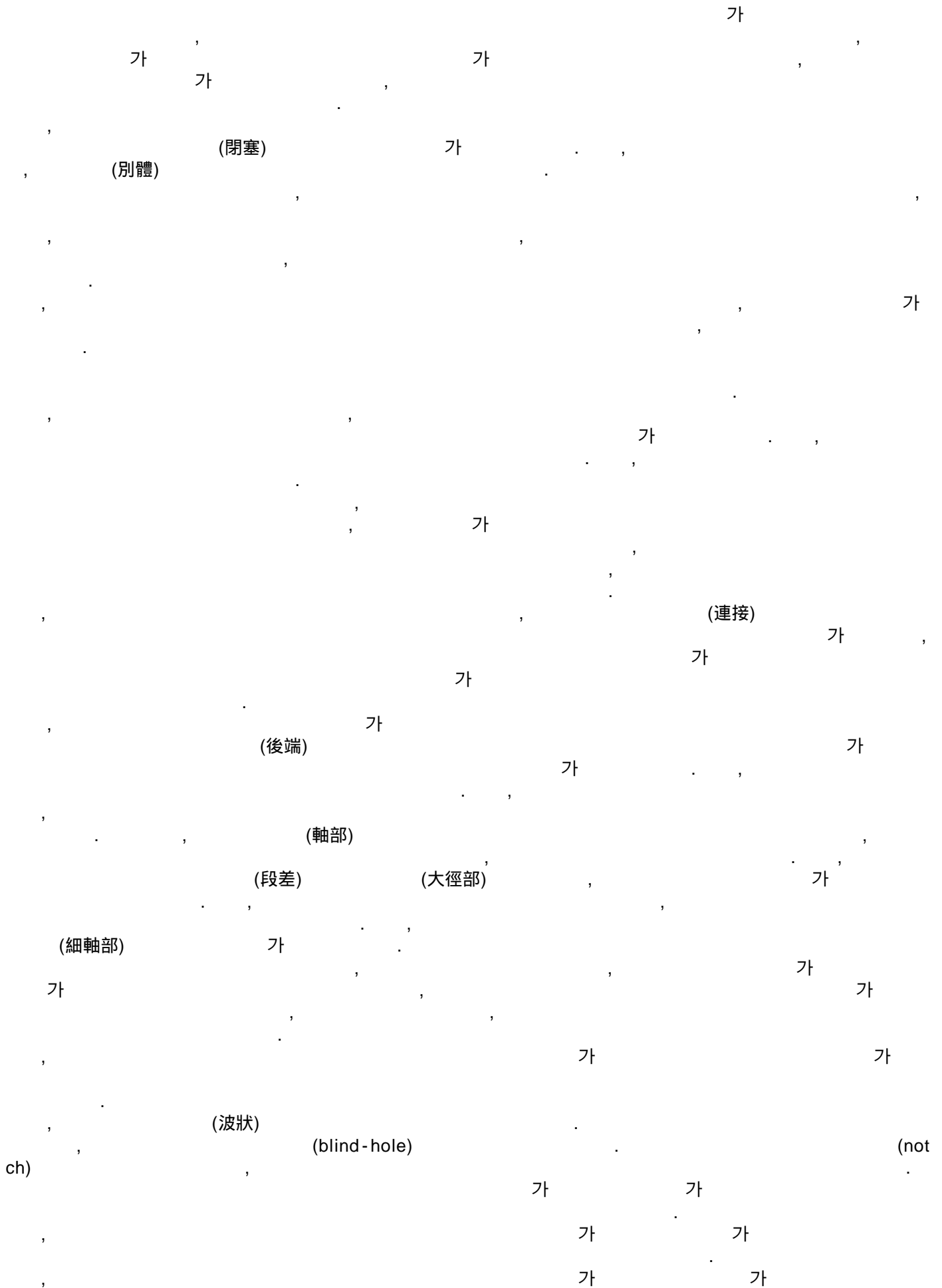

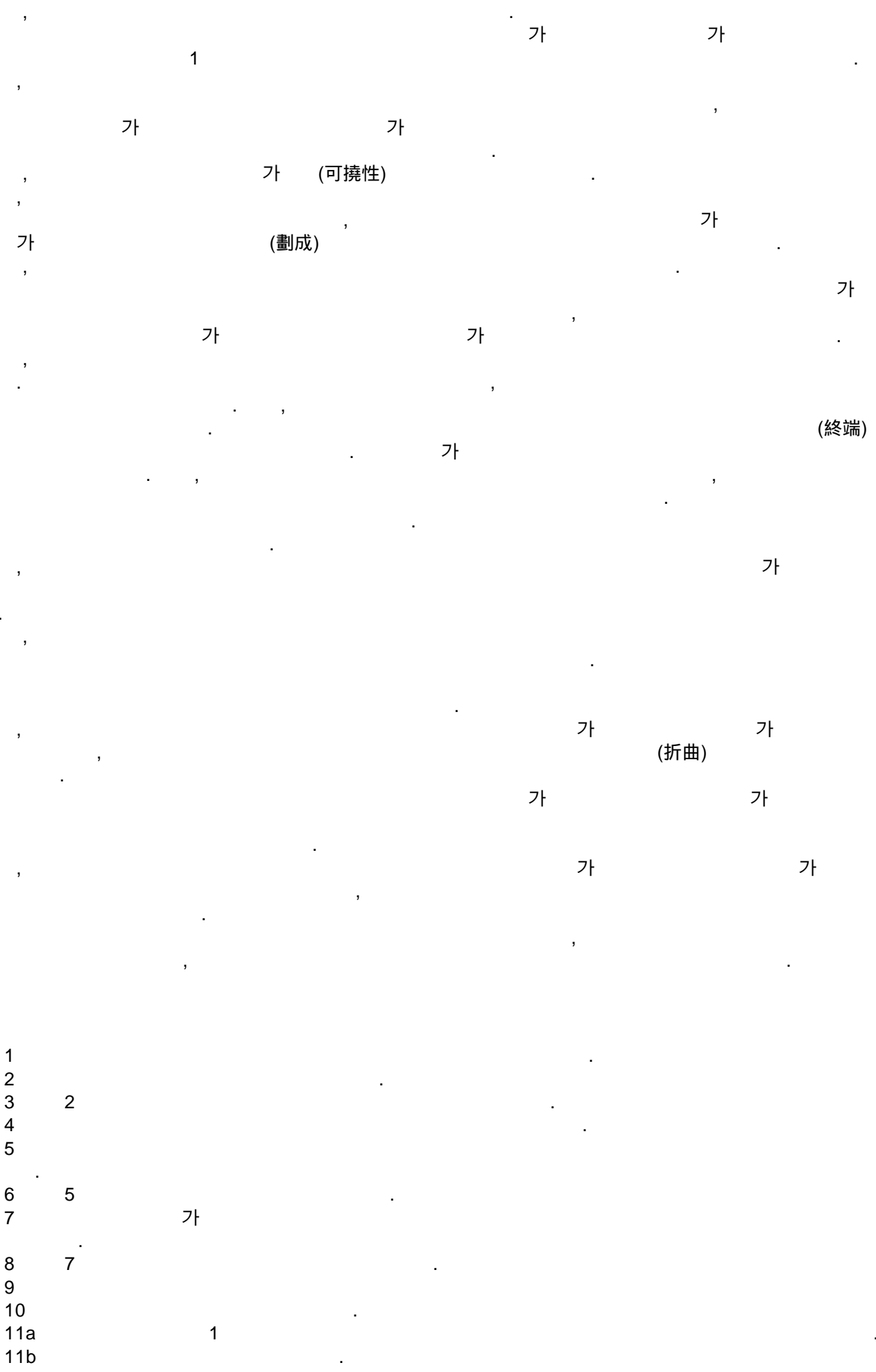

12a	11a		
12b	12a		
13a	12a		
13b	13a		
14		2	
15a		3	
15b			
16a		4	
16b			
17a		5	
17b			
18a		6	
18b			
19a		7	
19b		가	
19c		가	
19d		가	
20a		8	
20b			
21			
22	20a	-	
23	20b	-	
24a		9	
24b			
25	24a	-	
26	9		
27a		10	
27b			
28	27a	-	
29a	28	A-A	
29b	28	B-B	
29c	28	C-C	
30a	10		
30b			
31	27a		
32	31		
33	27a		
34a	33		
34b	34a		
34c			
35	34a		
36a	34a		
36b	36a		
36c	36a		
37	36a		36c
38		11	
39a	38		
39b			
40	39b	A-A	
41a		12	
41b	41a		
42a		13	
42b	42a		
43a		14	
43b	43a		
44	43a		
45a	14		
45b			

45c

1

0) (1) (5) (6) (溶着) (4) (2)
 4) (2) (3)가 (7) (
 (5) (20)가 (23) (23) (23)
 (24) (8)가 (底部) (4)
 (9) (9A) (23) (23A)가
 (23) (1) (23B)가
 (9) (9) (9A)가 (9A)가
 (2) (23) 가 가 (9B)
 (9) (15) 가 (23) (23)
 (9) (23) (9A, 23A)가 (4) (9) (9)
 (15) 가 (9A, 23A)
 (4) (7) (20) (26)가 (26)
 (7) (26) 가 (27)가 (26)
 (27) () (20)가 (4) (28) (28)
 0) (1) (21) (26) 가 (28a)(3) (28) (28)
 (26) (21) (9) (23) (1)가 (9A, 23A) (4) 가 (27)가
 (21) (8) (4) 가 (20) 가
 (21) (1) 가 (20) 가
 (30)(2 3)가 (21) (28) 가 (27)
 (30) (27a)가 (21a)
 (21) , 2 (20) 가 (21c)가
 (21c)가 (21c)가 (26) (2, 3) (21c)가
 (2, 3) (30) (21c)가 (21c)가 (21c)가 (灣)
 (30c)가 (26) (30c)가 (21) (arm部)(30b)가 (30a) (30b) (21)
 (山形) (21) (21c) (26) (30c) (21)
 (27) (21) (28) (30) (30c)
 (30c) (27) (27a)가 (30) (30c)
 (27a) (27)가 (30) (30)
 (27) (27)가 (27b)가 (27b)
 (27) 가 (27) (27) (27)
 (27) (27) (27a) (2, 3) 가 (29)
 (27) (27a) 가 (30) (30c)
 가 (28a)

(21)
4)가 (21), (32), (27), (7), (26), (32) (32, 32) (32, 27)
a) (27) (27b)가 (27a) 가 (32) (20)
(27) (30),
5 6 (27), (21), (30)
(26) (27c)가 (21) (30)
(21) (21a) (27) (21) (27c)가 (27) (27c)가 (30) (30c)
(27c) (21) (21) (21c) (30) (30c)
(30) (26) (21) (28) 가 (21) (21)
(27) (27c) (27c) (30) (27c) (30c) (30) 가 (21)
(27c) (20) (4) 가 (7) (7)
(20) (21) 가 (27) (27)
(26) (30) (30) 가 (27c) (21) (27) (27c) (21)
27)가 (21) (27) (27) (21)
(27) (27c) (30) (30) (27) (27)
7 9 (30) 가 (7) 7 8 (27) (3)
(27) 가 (10) (11) (7) 9 (2) (27) (3)
(7) (27) (26)가 (2) (27) (3)
(27) (18)) (26)가 (17a) (27) (17a) (26)가 (7c) (27) (3)
(18) (2, 3) (2, 3) (23) (2, 3) (10)
(11) (3) (12) (7) (7c) (7) (7c) (19) (27)
(7) (2, 3) (3) (3)
(10) (7) (2) (7) (7c) (27)
(10) (11) (12) (2, 3) (7) (7c) (11) (12)
(10) , (27) 가 (11) (12) (27) (27d)
, 7 (10)가 (17) (27) (27)
(11) , 9 (11a) (11b, 11b) (11a) (11c) (11b,
11b)가 (11b, 11b) (11a) (11) (11a) (11a)

(7) (18) (11) (11b, 11b) (18a, 18a)가
(7) (18) (11) (11) (11d) (18b)가
(11) (11d)가 (18) (11) (12) (11) (12) (18b)가
1b, 11b)가 (18) (18a, 18a) (11)가 (12) (11) (12)

9 가 (11) (10)
(11e) (11) (11a) (11b, 11b) (11a) (11b, 11b)
(7) (18) (11b, 11b) (11b, 11b) (18a, 18a)
(11) (27) (17) (10) (27) (27) (12) 가
(10)가 (11) (12) (27) (7) (7) (가
27)가 (10) (10) (11) (12) (7) (7) (가
(27) (27) (10) 가 가 (27) (17) ,
(17) (12) (2) (3) (10) (27) (27) (가
(11) (11b, 11b)가 (11b, 11b) (11) (12) (가
(11)가 (18) (11) (11) (11) (11) (12)
(27) 가 11a 45c
11a 1 11b
12a 12b
(7) (27) (17) (27)
가 (27) 12a 12b (27d) (36)가 (27b)
(27e)가 (27e) (36) (前端) (17) (27e) (17a) (27f)
(36) (前半)
(17) 11b (27)가 (36) 가 (27) (27d)
(17a) 가 (가
(27) (27e) 12a 12b 13a 13b
(27) (27d) (27g) (36) (27b)
(27g) 14 2 (27) (38) (27)
(27h) (27h) (38) (27f) (2) (3)
9) 40 (38) (38) 1
15a 15b 3 15a
15b 11a 11b 1 (27) (27e)가
41) (27e) 2 (36A, 36B) (36A)가
(36B) (36A, 36B) (27) (27)
(36B)가 (36A)가 (27) (27)
16a 16b 4 16a
16b 2 (36A, 36B) 2 (36A, 36B) (2)
7) (17) (36A)가 (36B)

(2, 3) , , (2) (42) ,
 가 (2) (36A) ,
 (3) (36B) 5 , 17a
 17a 17b , 17a
 17b ,
 (27) (17) (43) (3)
 (43) , 17b , 가
 18a 18b 6 , 18a ,
 18b ,
 17a (43) , , (44)
 (3) (27) (17) .
 5
 19a 19d 7 , 19a ,
 19b 19d 가 ,
 1 (36) , 2 (46a,
 46b) (46) (27) (17)
 , 19 , (46)가 ,
 (27) , 19b (46)가 ,
 19c 19d (46) 가 (46) (46a, 4
 6b) (支點) (46) 2 , (46a, 46b) .
 , 7 (46) 2 , (46a, 46b) ,
 , 1 3 (46) , (卷數) ,
 (46) ,
 20a 23 8 , 20a , 20b
 , 22 20a - , 23 20b -
 (27) , (27) 가
 , (27) (27d)((27)가) 가
 (48) , (27d) (27)가)
 , (27) (27d) (27) (50) .
 (48a, 48a) (27) (17) (48) (48)
 (27) (17) (48) (49)가
 (48) (27) , 22 (50, 50)가
 (48) (48a, 48a) (17) (50) (17)
 , (27) (50)가 , (50) (17)
 (48) (48a) 가 , 가 ,
 (27) (27) (17) , 23 ,
 (47) , (17) (49) (17)
 가 , 23 (47) (49) (17)
 (48) 가 , (48)
 (49) .
 24a, 24b 25 9 , 24a
 , 24b , 25 24a -
 (50) , (27)
 (17) , (27) (51, 51) 25 , (27)
 , (17) a b
 (50)가 .

a (50) , (50) , 가 (50) ,
 19 , 26 (17) , (47') ,
 (7) (46) 가 ,
 , (51, 51) (2, 3) , 25
 , (51, 51) (2) (3) ,
 (7) (50) (2) (3) ,
 , 27a 29c 10 , 27a
 , 27b , 29a 28 A-A , 29b 28 B-B 27a - 29c 2
 8 C-C (27d)((27)가 (50)) , (52) (27)
 , (52) (50)가 , (50)
 , 29c , 25
 , (17) (7) (52) , 29a (53a) (53)
 , (27) (17) , (52) , 29c (53a)
 (52) (52) , (50)가 (52)
) (53a) 가 , (50)가 (52)
 (50) (終端) (53) , 30a , (52)
 (52) (27) , (3) (50)가 (52)
 , 30b , (50)가 (27) , (27e) , (2)
 7e) , 31 32 (27f) (52) (27f) (50) (50)
 , (7) (7a) (50) (50)
 (50) (52) (50) (50)
 , 33 (52a) , (50) (52) (50) (適性)
 , (52) (50) (52) (52)
 , (52) , 34a , (52)
 (52b, 52b) (53) (53a) , (53a) , 34b
 , (52b, 52b) (52) (53) (53a)
 , (53a) , (50) (52) (53) (52b, 52b)
 (52) , 29a , 29c (52b, 52b) (52)
 , (50) (53) (50) , 35 (50a)
) , (50) (剛性) , (27) ,
 , 가 , 36a , 36a 36c , (27) ,
 , 36a , 36b (52) , 34a 34c , 36c
 (52c) , (52c) (細徑部)(52d) , (52d)
 (基端部)(52e) (52) , (52e)
 , (52) (50) (27) (54)
 38 40 37 (27) , 38 , 36c
 , 39a 11 , 38 , 39b A-A , 39b
 , 가 , 가 , 40 39b A-A , 39b

(27)가 (7) (2, 3)
(27) (27) 가 (60)가 (7) (55a)
(50)가 (55) 1 (26) (55)
가 (60) (7) (50) (50) (55)
55) (27) (50) (55)
39a 39b (27) (17)
(55b) (55b) (27)
(27k) (50) (55)
39a (27) (27k) (55b) (27)
(27) (60) (7) 39b (27)
27) 가 (27k) (55b) (55b)
(50) 40 (27)
(55c)가
(7) 가 (27) (50) (55) (60)
(50) (7) (60) (27)
(27) 가 (27) 가 (27) 41a 가
(56) (56a) 41b (27) 12 (57)
13 가
42a 42b (27) (27)
(58)
43a, 43b 44 14 43a 43b
(27) 44 가 (62) (61)
62) (43a) (43b) (61b) (61) (61a) (61a) (61c)
(62) (27) (blade部)(61c, 61c) (27m, 27m) (61c)
, 61c) (27) (61) (62) (62)
(61) (62) (61)
45b 45c 45a 가
가 (折線)

(57)

1.

가 , 가 , 가
(着脫) 가 , 가

2.

1 , (閉塞)

- 1 3. 가 , (別體)
- 4. 가 , 가 , 가
- 가 , 가
- 4 5. , ,
- 4 6. , ,
- 4 7. , ,
- 8. 가 , 가
- 가 , 가 , 가 , 가
- 가 , (連接) , 가 , 가
- 가 , 가
- 8 9. , 가 (後端) , 가
- 9 10. , ,
- 8 11. , 가 ,
- 가
- 11 12. , (軸部) , 가 ,
- 11 13. , (段差) (大徑部)가 ,
- 가 , 가
- 11 14. , ,

가 ,

15.

8

,

(細軸部)

16.

가

가

,

가

가

가

가

17.

16

,

(波狀)

18.

16

,

(blind-hole)

19.

16

,

(notch)

20.

가

가

,

가

가

가

가

21.

가

가

,

가

가

가

가

22.

가

가

,

가

가

가

가

23.

22

,

가

24.

가

가

,

가

가

가

가

25.

1

가

,

가

가

가

가

가

26.

25

가 (可撓性)

27.

가

가

가

가

가

가

(劃成)

28.

27

29.

가

가

가

가

가

가

가

30.

29

31.

29

32.

29

가

33.

29

(終端)

가

34.

33

가

35.

34

36.

29

37.

29

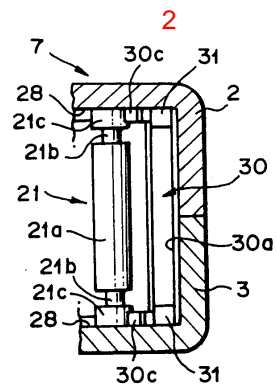
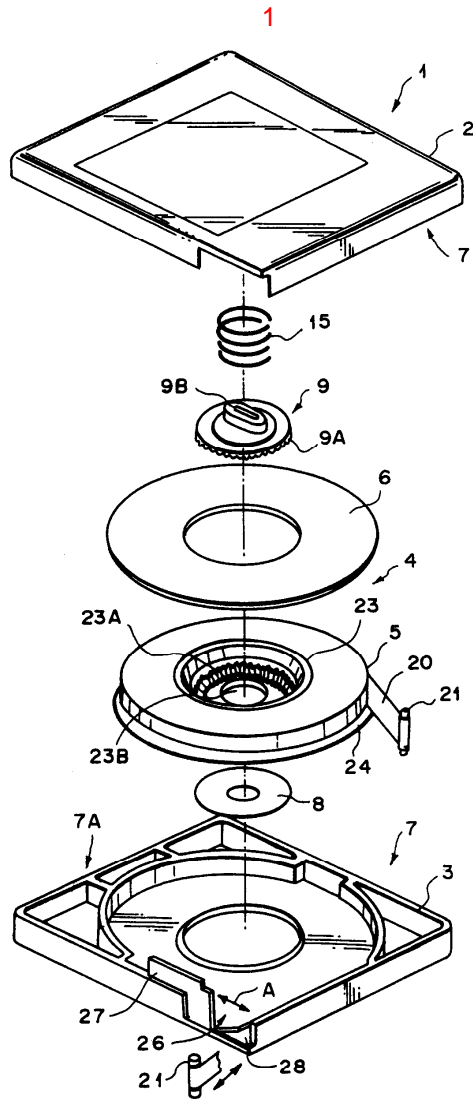

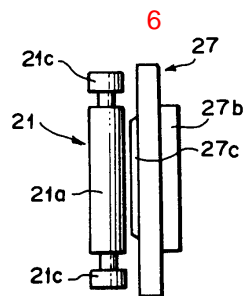
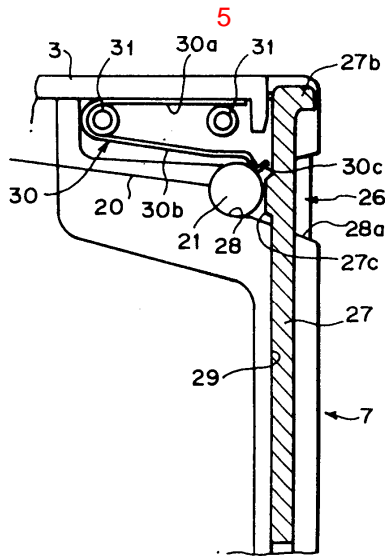
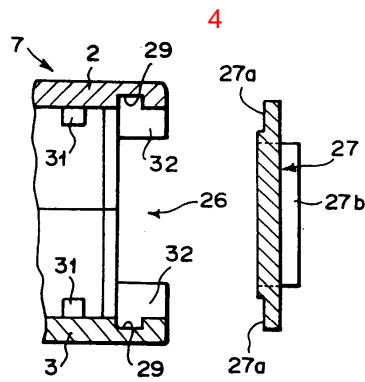
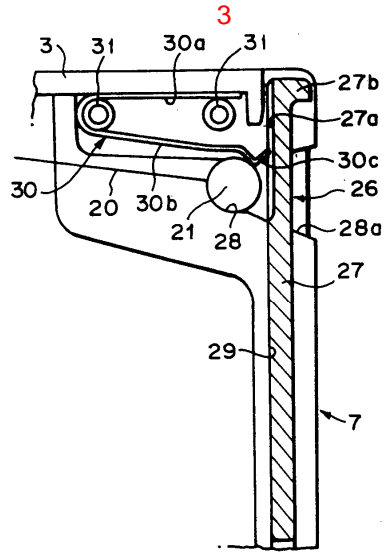

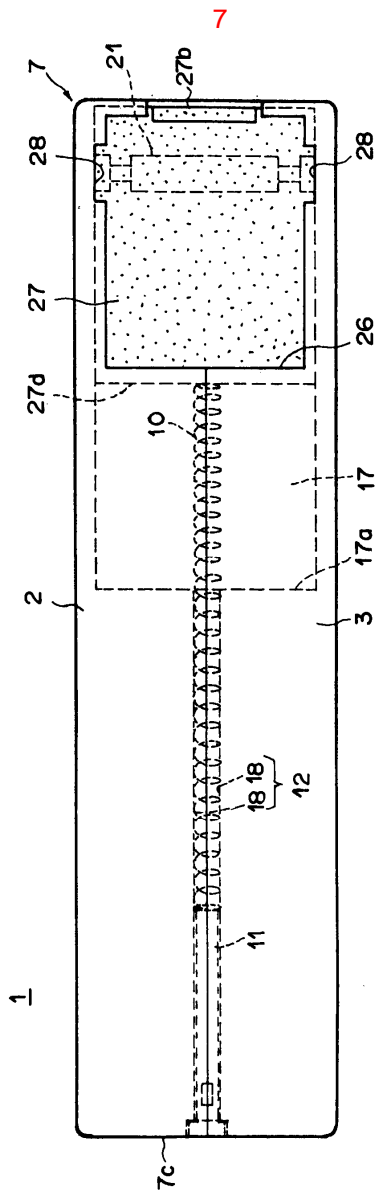

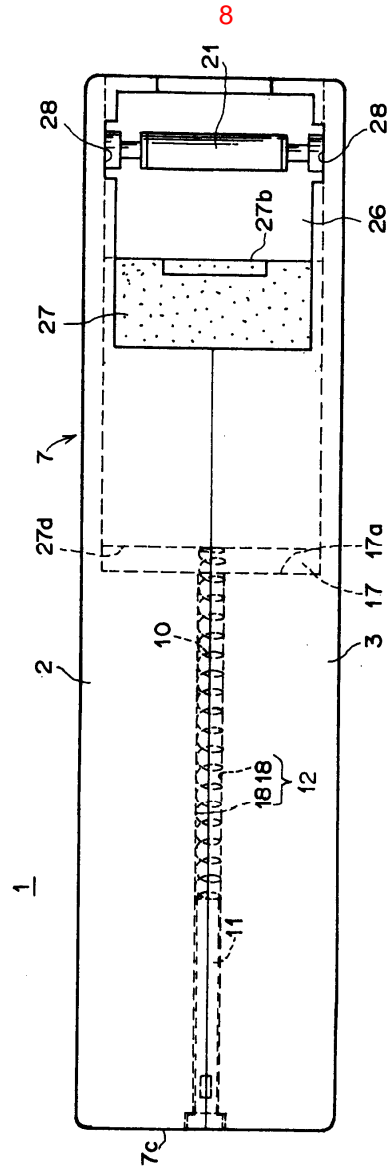

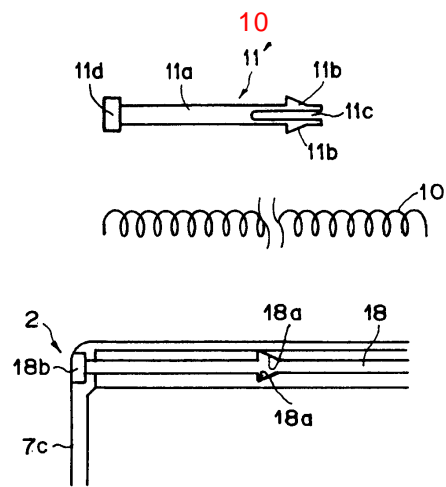
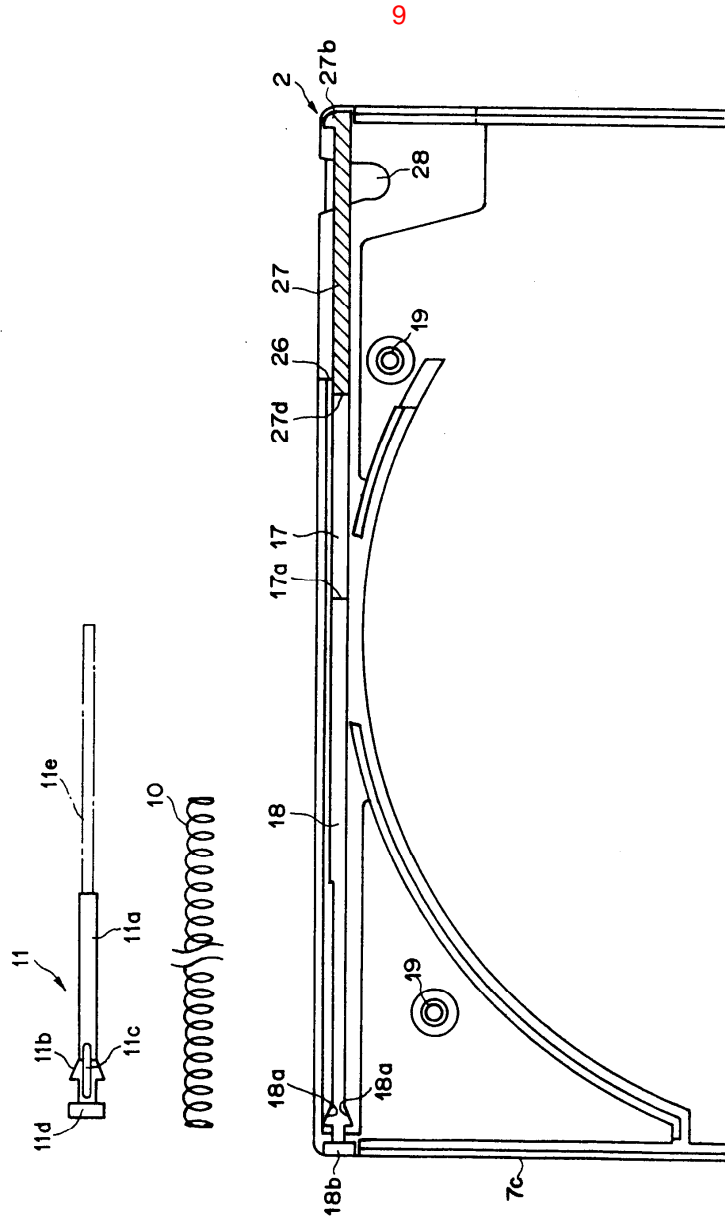

11

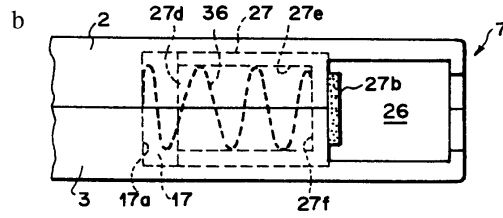
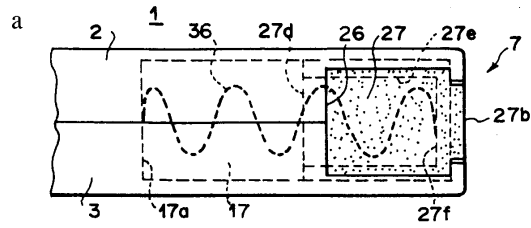

12

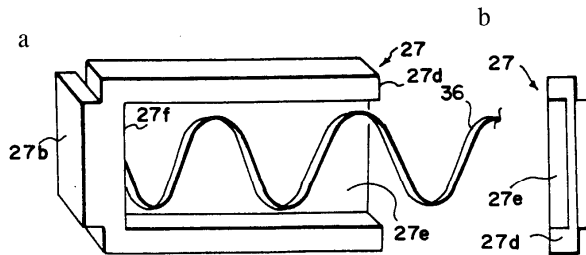

13

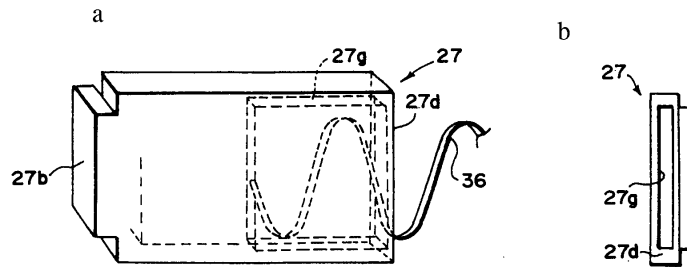

14

