



US 20180051550A1

(19) **United States**

(12) **Patent Application Publication**

**REN et al.**

(10) **Pub. No.: US 2018/0051550 A1**

(43) **Pub. Date: Feb. 22, 2018**

(54) **MEASUREMENT-WHILE-DRILLING  
DEVICE AND METHOD**

**Publication Classification**

(71) Applicant: **GENERAL ELECTRIC COMPANY,**  
Schenectady, NY (US)

(51) **Int. Cl.**  
*E21B 47/00* (2006.01)  
*E21B 47/01* (2006.01)  
*E21B 7/04* (2006.01)

(72) Inventors: **Zhiguo REN,** Shanghai (CN); **Xu FU,**  
Shanghai (CN)

(52) **U.S. Cl.**  
CPC ..... *E21B 47/0006* (2013.01); *E21B 47/011*  
(2013.01); *E21B 47/12* (2013.01); *E21B 47/00*  
(2013.01); *E21B 7/04* (2013.01)

(21) Appl. No.: **15/556,815**

(22) PCT Filed: **Mar. 9, 2016**

(86) PCT No.: **PCT/US2016/021424**

§ 371 (c)(1),

(2) Date: **Sep. 8, 2017**

(57) **ABSTRACT**

A measurement-while-drilling device comprises a base (21) to be connected between the drill pipe and the drill bit, the base having first and second end surfaces (212, 213) at the two axial ends thereof, at least one sensing chamber (22) which has an opening at at least one of the end surfaces, and a passage (23) for circulation of drilling fluid, at least one sensor disposed within the sensing chamber, and a sealing member (26) for sealing the sensing chamber on the at least one end surface.

(30) **Foreign Application Priority Data**

Mar. 9, 2015 (CN) ..... 201510101508.5

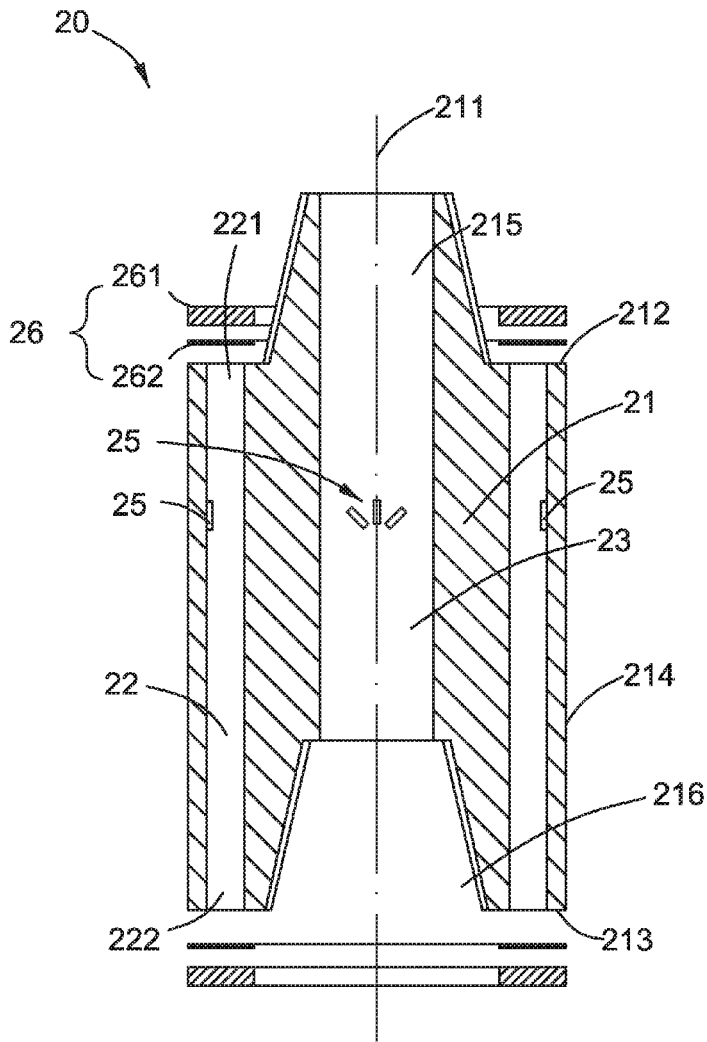

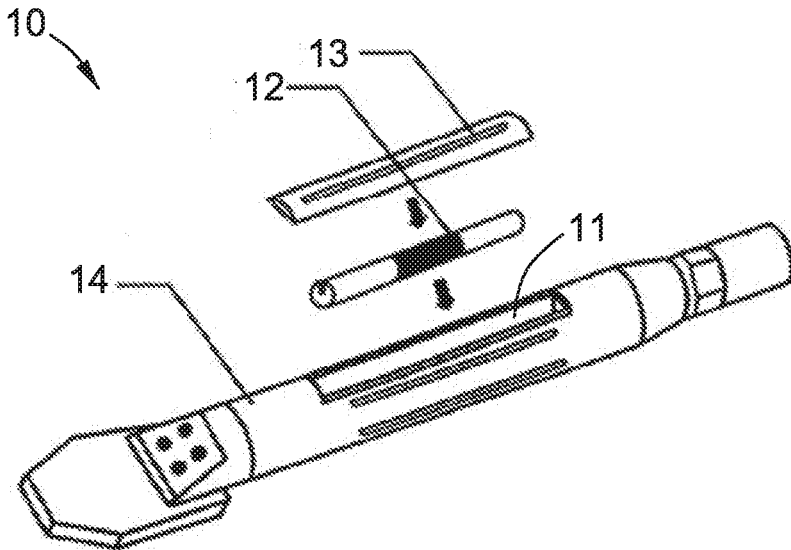

Fig. 1

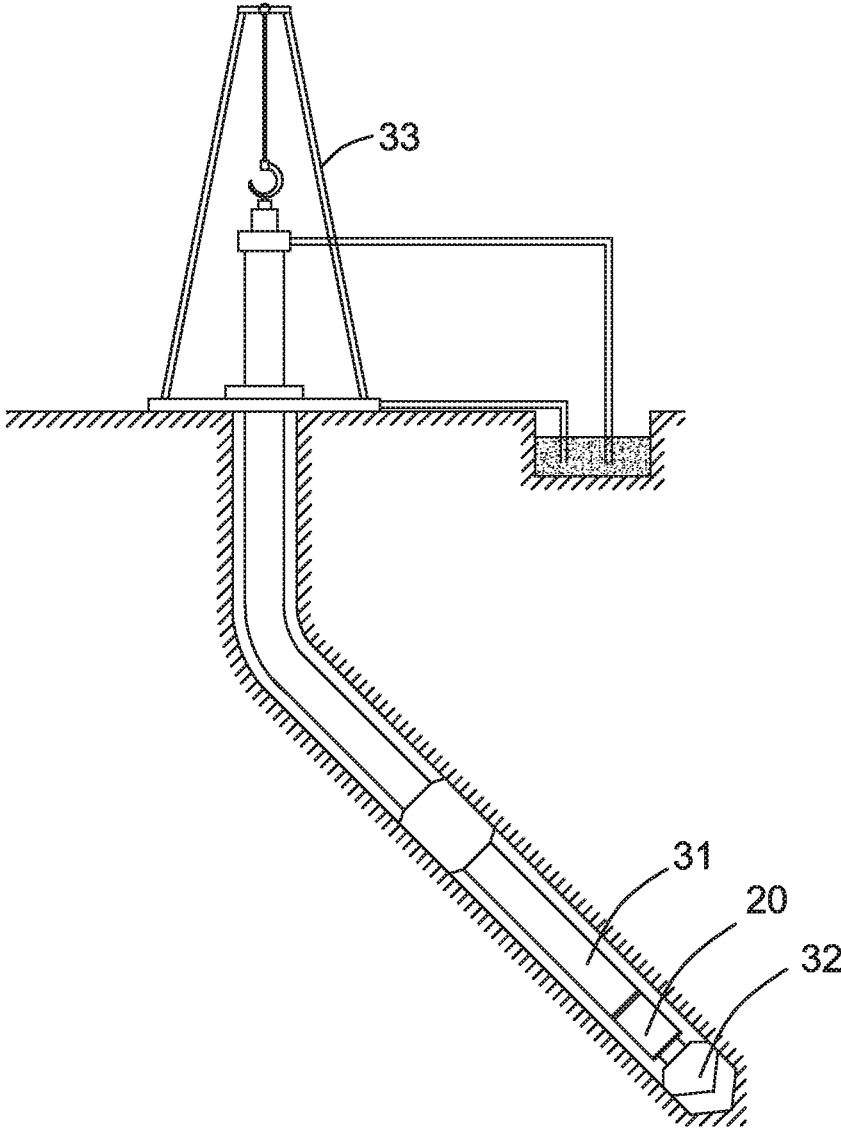

Fig. 2

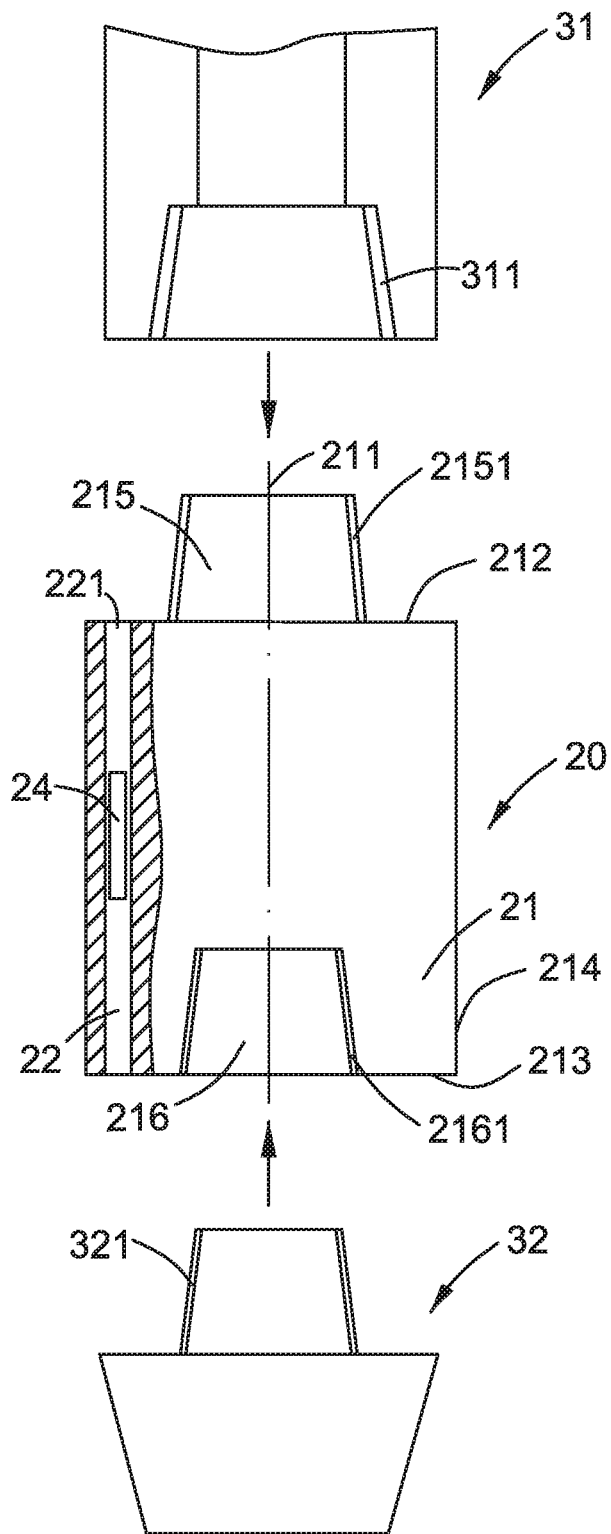

Fig. 3

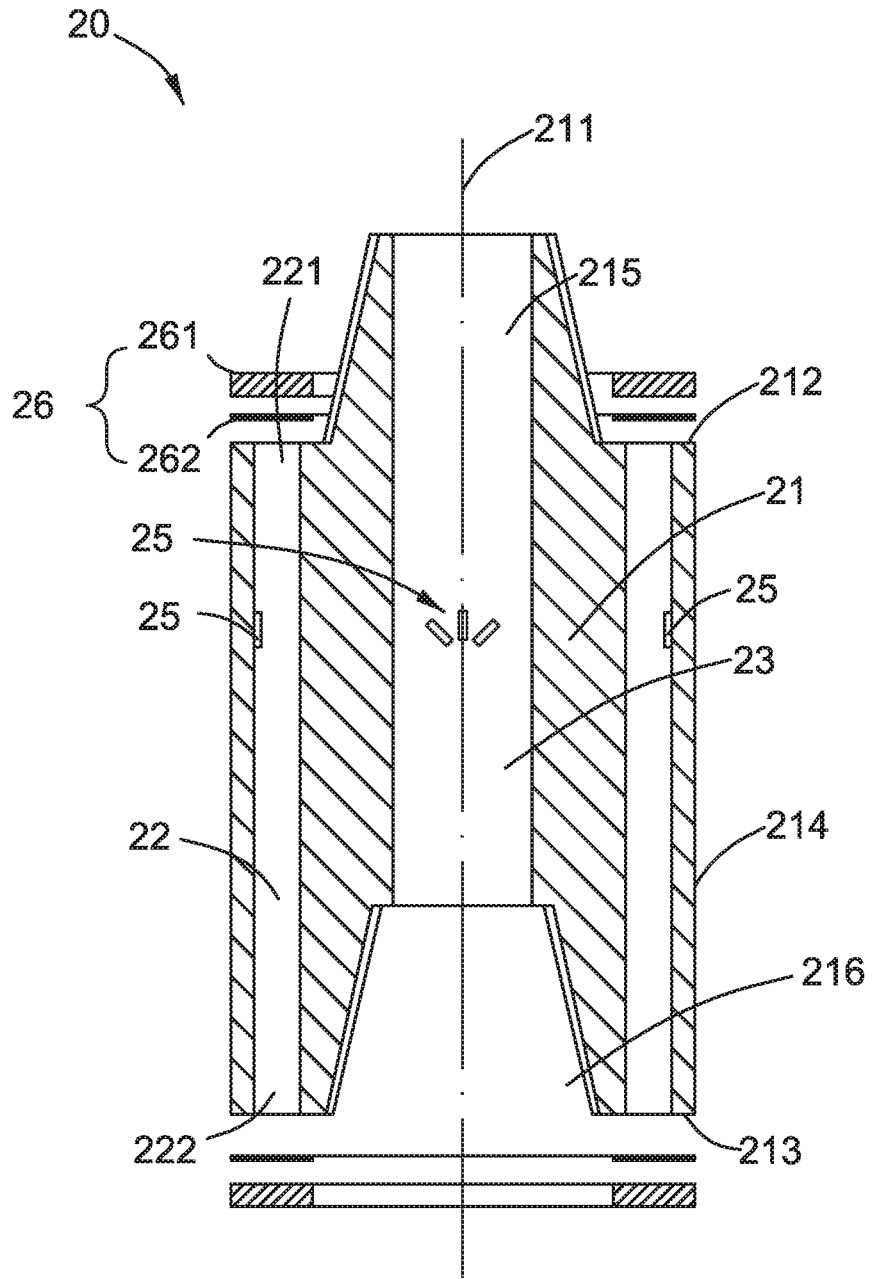

Fig. 4

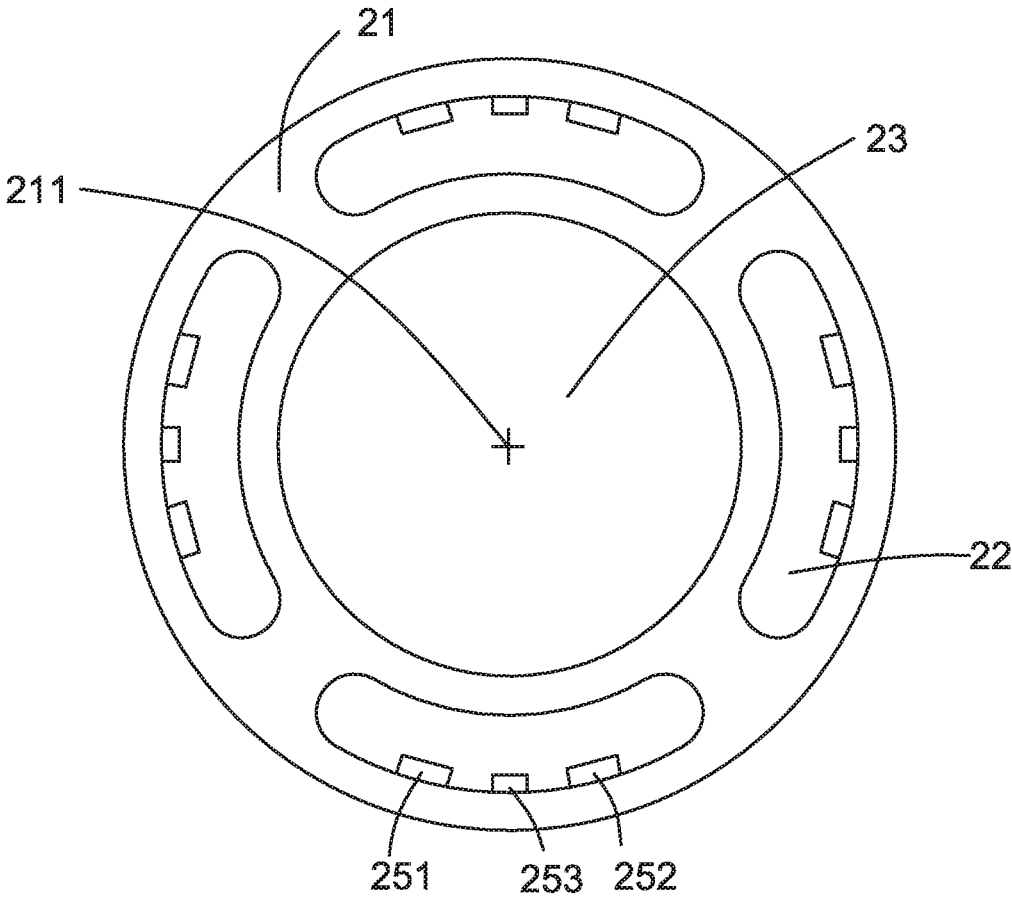

Fig. 5

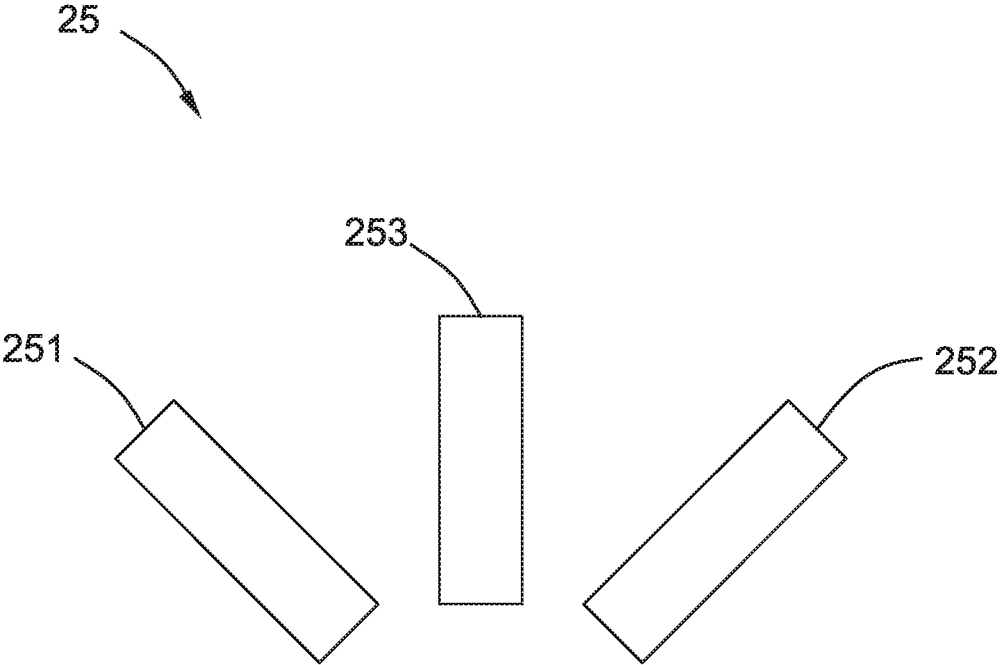

Fig. 6

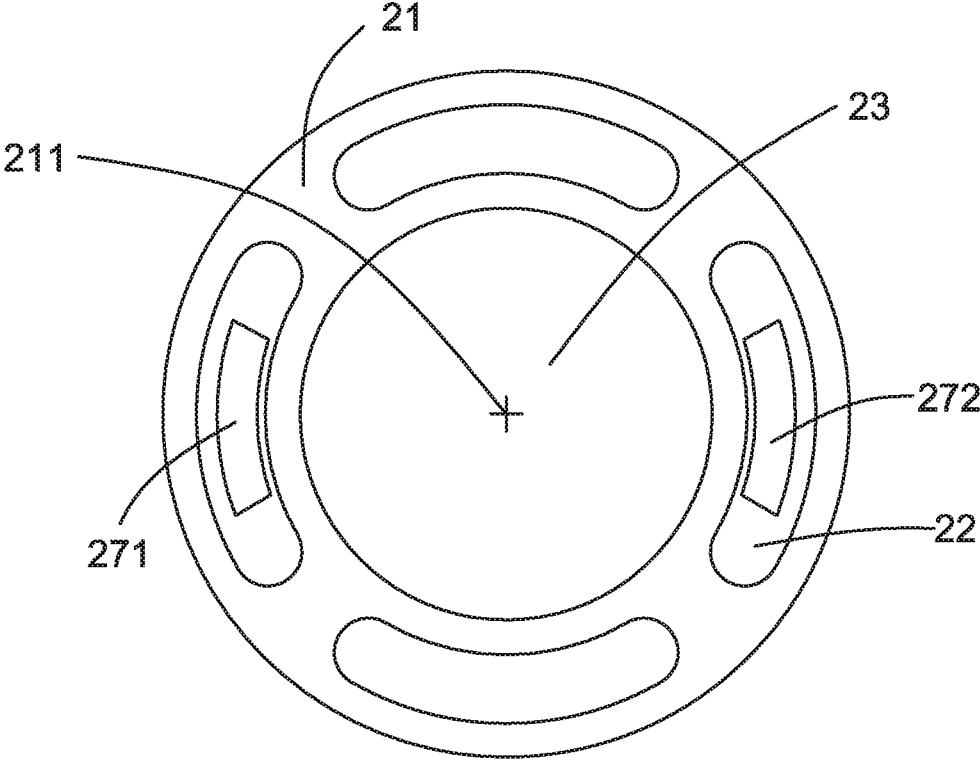

Fig. 7



## MEASUREMENT-WHILE-DRILLING DEVICE AND METHOD

### TECHNICAL FIELD

[0001] The embodiment of the present invention relates to a measurement device and a corresponding measuring method, and in particular, to a measurement-while-drilling device and a measuring method suitable for a drill apparatus.

### BACKGROUND

[0002] The term “measurement-while-drilling” means that a drill machine, when it is drilling, collects continually the information about the drill well or a drill bit, such as an azimuth angle, stress, bit pressure, operation conditions of the drill bit, and the subsurface environment, and then the information is transmitted back to a control end so as to act as the basis of producing a control signal. Accordingly, the measurement-while-drilling device is the key to implement the technology of rotation drilling.

[0003] Most of measurement-while-drilling devices are disposed in a drill collar, and their core components are various sensors disposed therein. Because the subsurface environment presents complex and harsh extremely, the sealing of the housing of a measurement-while-drilling device becomes very important. A well-sealed housing is capable of protecting the sensors from the invasion of drilling liquids, sands, or the like, thereby improving the accuracy of the measurement of the sensors and prolonging the life of the sensors. As shown in FIG. 1, in the prior art, an axial groove 11 is provided at a cylindrical peripheral side surface 14 of a measurement-while-drilling device 10, and after the sensor 12 has been installed therein, a cover 13 is provided on the groove to serve for sealing. By the measurement-while-drilling device of this design, it is convenient for the installation and maintenance of the sensor 12. However, the design is of a complex structure, and the sealing effect and accuracy cannot be guaranteed.

[0004] Accordingly, it is necessary to provide a measurement-while-drilling device adaptable for a drill apparatus, and a corresponding method of producing the same, so as to solve the above-mentioned technical problems.

### SUMMARY

[0005] In light of the aforementioned technical problems, one aspect of the present invention is to provide a measurement-while-drilling device, comprising a base having a rotation axis and configured to be axially connected between a drill pipe and a drill bit of a drill apparatus. The base has a first and second end surfaces at the two axial ends thereof respectively and a cylindrical peripheral side surface extending between the first and second end surfaces. The base defines at least one sensing chamber which has an opening at at least one of the end surfaces. The base further includes a passage which is configured to allow liquid communication between the drill pipe and the drill bit. The measurement-while-drilling device further comprises at least one sensor disposed within the sensing chamber, and the sensor and the sensing chamber are configured to obtain drilling data and transmit the drilling data to a drilling control unit. The measurement-while-drilling device further comprises a sealing member configured to seal the sensing chamber on the at least one of the end surfaces.

[0006] Another aspect of the present invention is to provide a method, comprising: designing a predetermined drilling trajectory which leads to hydrocarbon to be produced; drilling a well bore with a drill apparatus comprising a measurement-while-drilling device based on the predetermined drilling trajectory; removing the drill apparatus from the well bore; and obtaining the hydrocarbon from the well bore. The step of drilling a well bore with a drill apparatus comprising a measurement-while-drilling device, comprises: obtaining drilling data with the measurement-while-drilling device, transmitting the drilling data to a drilling control unit, and calibrating a drilling direction of the drill apparatus based on the drilling data and the predetermined drilling trajectory. The measurement-while-drilling device comprises a base having a rotation axis configured to be axially connected between a drill pipe and a drill bit of the drill apparatus. The base has a first and second end surfaces at the two axial ends thereof respectively and a cylindrical peripheral side surface extending between the first and second end surfaces. The base defines at least one sensing chamber which has an opening at at least one of the end surfaces. The base further includes a passage which is configured to allow liquid communication between the drill pipe and the drill bit. The measurement-while-drilling device further comprises at least one sensor disposed within the sensing chamber. The measurement-while-drilling device further comprises a sealing member configured to seal the sensing chamber on the at least one of the end surfaces.

[0007] Another aspect of the present invention is to provide a method for producing a measurement-while-drilling device, comprising: providing a base having a rotation axis, configured to be axially connected between a drill pipe and a drill bit of a drill apparatus and having a first and second end surface at the two axial ends thereof respectively and a cylindrical peripheral side surface extending between the first and second end surfaces; forming at least one sensing chamber in the base which has an opening at at least one of the end surfaces; forming a passage in the base which is configured to allow liquid communication between the drill pipe and the drill bit; disposing at least one sensor in the sensing chamber from the opening of the sensing chamber; and sealing the sensing chamber on the at least one of the end surfaces.

### BRIEF DESCRIPTION OF THE DRAWINGS

[0008] The present invention can be understood better in light of the following description of embodiments of the present invention with reference to the accompanying drawings, in which:

[0009] FIG. 1 is a schematic view of a measurement-while-drilling device in prior art;

[0010] FIG. 2 is a schematic view of a directional drilling system according to a specific embodiment of the present invention;

[0011] FIG. 3 is an erection view of a measurement-while-drilling device according to a specific embodiment of the present invention;

[0012] FIG. 4 is a structural view of a measurement-while-drilling device according to a specific embodiment of the present invention;

[0013] FIG. 5 is a sectional view of the measurement-while-drilling device in FIG. 4;

**[0014]** FIG. 6 is a schematic view of strain gauges of the measurement-while-drilling device in FIG. 4;

**[0015]** FIG. 7 is a sectional view of a measurement-while-drilling device according to another specific embodiment of the present invention.

#### DETAILED DESCRIPTION

**[0016]** Hereinafter, a detailed description will be given for preferred embodiments of the present utility model. It should be pointed out that in the detailed description of the embodiments, for simplicity and conciseness, it is impossible for the Description to describe all the features of the practical embodiments in details. It should be understood that in the process of a practical implementation of any embodiment, just as in the process of an engineering project or a designing project, in order to achieve a specific goal of the developer and in order to satisfy some system-related or business-related constraints, a variety of decisions will usually be made, which will also be varied from one embodiment to another. In addition, it can also be understood that although the effort made in such developing process may be complex and time-consuming, some variations such as on design, manufacture and production on the basis of the technical contents disclosed in the disclosure are just customary technical means in the art for those of ordinary skilled in the art relating to the contents disclosed in the present utility model, which should not be regarded as insufficient disclosure of the present utility model.

**[0017]** Unless defined otherwise, all the technical or scientific terms used in the Claims and the Description should have the same meanings as commonly understood by one of ordinary skilled in the art to which the present invention belongs. The terms “first”, “second” and the like in the Description and the Claims do not mean any sequential order, number or importance, but are only used for distinguishing different components. The terms “a”, “an” and the like do not denote a limitation of quantity, but denote the existence of at least one. The terms “comprises”, “comprising”, “includes”, “including” and the like mean that the element or object in front of the “comprises”, “comprising”, “includes” and “including” cover the elements or objects and their equivalents illustrated following the “comprises”, “comprising”, “includes” and “including”, but do not exclude other elements or objects. The term “coupled” or “connected” or the like is not limited to being connected physically or mechanically, nor limited to being connected directly or indirectly.

**[0018]** The terms “may”, “might”, “can” and “could” in the present application indicate the possibility of occurrence in case of some environments, have a certain property, feature or function; and/or by combining with a qualified verb, indicate one or more capacities, functions or likelihood. Correspondingly, the use of “may” indicates that the modified terms are apparently appropriate, matchable or suitable; at the same time, in view of the presence of some situations, the modified term may be not appropriate, matchable or suitable. For example, in some cases, a result or performance may be expected to appear; while in other cases, it may not appear. This difference is embodied in the terms signifying “may”.

**[0019]** One aspect of the embodiment of the present invention is adaptable for a measurement-while-drilling device of a directional drilling system. FIG. 2 is a schematic view of a directional drilling system, which includes a drill

rig 33, a drill pipe 31 and a drill bit 32. The measurement-while-drilling device 20 is disposed between the drill pipe 31 and the drill bit 32, in order to detect the information about the drill pipe and the drill bit, and send the information back to a control end, so as to act as the basis of producing a control signal.

**[0020]** FIG. 3 is an erection view of a measurement-while-drilling device according to a specific embodiment of the present invention. With reference to FIG. 3, the measurement-while-drilling device 20 may be axially connected between the drill pipe 31 and the drill bit 32 of the drill apparatus, and coaxial with both of them. In some embodiment, the measurement-while-drilling device 20 is substantially a cylindrical body. When the drill apparatus is operating, the measurement-while-drilling device 20 rotates with the drill pipe 31 and the drill bit 32, measures the various parameters for the drill pipe and the drill bit in real time by the sensor(s) 24 therein, forms the drilling data, and transmits the data to a drilling control unit. Then the drilling control unit controls the drilling direction, the drilling speed or the like of the drill apparatus according to the data.

**[0021]** FIG. 4 is a structural view of a measurement-while-drilling device according to a specific embodiment of the present invention. As shown in FIG. 4, the measurement-while-drilling device 20 includes a base 21 having a rotation axis 211 and having a first and second end surfaces 212, 213 at the two ends thereof respectively, a cylindrical side surface 214 extending between the first and second end surfaces 212, 213. In some embodiment, the rotation axis 211 is not a solid shaft, but a straight line in geometry, around which the base 21 rotate.

**[0022]** In some embodiment, either of the end surfaces is a plane and is angled with the cylindrical side surface 214. Further, in some embodiment, the base 21 is substantially a cylindrical body, such that the two end surfaces present circular, and perpendicular to the rotation axis 211.

**[0023]** There are two connecting parts at the two axial ends of the base 21, such that the base 21 is connected between the drill pipe 31 and the drill bit 32. Particularly, the base 21 has a first connection part near the first end surface and a second connection part near the second end surface, which are used for coupling with the drill pipe 31 and the drill bit 32 respectively.

**[0024]** With reference to FIG. 3, in some embodiment, the first connection part is a protrusion part 215 protruding from the first end surface 212. There are male threads 2151 on the curved surface of the protrusion part 215, and female threads 311 on the drill pipe 31 for matching with the male threads 2151, such that the base 21 and the drill pipe 31 are connected by the threads 2151 and 311. The second connecting part is a recessed part 216 recessing inwards from the second end surface 213. There are female threads 2161 on the inner wall of the recessed part 216 and male threads 321 on the drill bit 32 for matching with the female threads 2161, such that the base 21 and the drill bit 32 are connected by the threads 2161 and 321.

**[0025]** In some embodiment, the protrusion portion 215 may be a cylindrical body, or a truncated cone as shown in FIGS. 3 and 4, but not limited to this. The protrusion portion may be a cylindrical cavity with a half enclosed, or a truncated-cone cavity as shown in FIGS. 3 and 4, but not limited to this.

**[0026]** In this embodiment, the base 21 is connected with the drill pipe 31 and the drill bit 32 in a threading way, but

not limited to this. The base **21** may also be connected with the drill pipe **31** and the drill bit **32** in other ways such as by snaps, bolts or the like.

**[0027]** The base **21** defines a passage **23** therein for the liquid communication between the drill pipe **31** and the drill bit **32**. In some embodiment, as shown in FIGS. **4** and **5**, the passage **23** goes through the base **21** along the rotation axis **211** and presents a cylindrical cavity coaxial with the base **21**.

**[0028]** With reference to FIG. **3**, the base **21** further defines at least one sensing chamber **22** therein for accommodating the sensor(s) **24** of the measurement-while-drilling device. The sensing chamber **22** has at least one opening **221** on the first end surface **212**. The opening of the sensing chamber in prior art as shown in FIG. **1** is located on the cylindrical peripheral side surface. In such a way, the installation and maintenance of the sensor **12** is convenient, but because of the assemblies such as the cover **13** near the sensor **12**, there may be unpredictable and very unstable inner force among the assemblies or between the assemblies and the base, which may reduce sharply the measurement accuracy of the sensor **12**. In addition, there is a complex connection between the cover **13** and the opening of the groove **11**, hence the sealing performance of the equipment cannot be ensured. In contrast, in the present invention, there is no opening on the cylindrical peripheral side surface **214**, and the sensor **24** is disposed near the axially middle portion of the base **21**. In this way, when the sensor **24** is placed into the sensing chamber **22** from the opening **221**, the structure near the cross section of the sensor **24** perpendicular to the rotation axis **211** is simple and stable, and there is no other assemblies than the base **21** to interact with the sensor, such that there is no undefined or unstable inner force to affect the measurement accuracy of the sensor **24**, thereby improving the measurement accuracy of the sensor **24** greatly.

**[0029]** Continuing to see FIG. **3**, at least one sensor **24** is disposed within the sensing chamber **22**. In some embodiment, the sensor may be a strain component, a 3D (three-dimension) accelerometer, or the combination thereof, and dependent on the requirements, it may be other type of sensor or the combination thereof, but not limited to it.

**[0030]** With reference to FIG. **4**, the measurement-while-drilling device further includes a sealing member **26** disposed on the end surface for sealing the sensing chambers **22**. In some embodiment, the seal **26** includes a cover **261** and a sealing pad **262** on the at least one end surface. The sealing pad **262** is disposed between the cover **261** and the at least one end surface for improving the sealing effect of the cover **261**.

**[0031]** With reference to FIGS. **4** and **5**, furthermore, in some embodiment, the four cylindrical sensing chambers **22** pass through the cylindrical base **21** along the direction of the rotation axis **211**. Each of the sensing chambers **22** has two openings **221**, **222**, disposed on the first and second end surfaces **212**, **213** respectively. Each of the end surfaces **212**, **213** is disposed with a cover **261** and a sealing pad **262**, both of which are annular, in order to cover the four openings on each end surface, and free the impact on the operations of the connection parts **215**, **216** and the passage **23**.

**[0032]** In some embodiment, each of the sensing chambers **22** has a shape in conformity with the cylindrical peripheral side surface, such that the interior space of the base **21** can be made full use of, and the inner volume of the sensing chamber **22** can be increased. With reference to FIGS. **4** and

**5**, the base defines four cylindrical sensing chambers **22** between the outside of the passage **23** and the cylindrical periphery side surface **214** of the base **21**, which are disposed evenly around the passage **23** and each of which has a cross section of long curved ellipse.

**[0033]** In some embodiment, the sensor **24** includes at least two strain components **25**. As shown in FIGS. **4-6**, each of the strain components **25** includes a first, second and third strain gauges **251**, **252**, **253** disposed on the inner wall of the sensing chamber **22** along three different directions, for measuring the pressure, moment, side force or the like, of the drill bit. By such a combination of the strain components, various forces and moments on the drill bit may be separated, which further improves the measurement accuracy.

**[0034]** In some embodiment, the first, second and third strain gauges **251**, **252**, **253** are mounted on the side of the inner wall of the sensing chamber **22** near the cylindrical periphery side surface **214**. As shown in FIG. **5**, each of the strain gauges has a larger deformation amount on the side near the cylindrical periphery side surface **214** than on the other side, such that the signal to noise ratio of the strain component **25** can be increased, and the measurement accuracy can be improved.

**[0035]** FIG. **6** is a schematic view of strain gauges **25** of the measurement-while-drilling device. As shown in FIG. **6**, the first and second strain gauges **251**, **252** are symmetric to the third strain gauge **253**. In some embodiment, the angle between the first strain gauge **251** and the third strain gauge **253** is about 45 degree, such that the angle between the first strain gauge **251** and the second strain gauge **252** is about 90 degree, which makes the calculation simple, and improves the precision of the measured results.

**[0036]** In some embodiment, the sensor **24** further includes one or more pairs of 3D accelerometers, wherein each pair of 3D accelerometers are disposed symmetrically to the rotation axis **211** of the base, and by the combination of two 3D accelerometers, the motion parameter and the vibration parameter of the rotation of the drill bit is separated. In particular, by adding the signals of each pair of 3D accelerometers, the centrifugal acceleration of the two 3D accelerometers is counteracted, so as to eliminate the negative impact produced by the centrifugal acceleration of a single 3D accelerometer, such that the measurement accuracy of the measurement-while-drilling device **20** for the vibration is improved. In addition, the rotation speed of the drill bit may be measured more accurately through the subtract of the signals of each pair of 3D accelerometers.

**[0037]** In some embodiment, the 3D accelerometers may be integral, or replaced with three one-dimension accelerometers, or with one two-dimension accelerometer and one one-dimension accelerometer.

**[0038]** With reference to FIG. **7**, in some embodiment, the measurement-while-drilling device **20** includes two 3D accelerometers **271**, **272** disposed along the same line through the rotation axis **211**, and distant equally from the rotation axis **211**.

**[0039]** The sensor **24** and the sensing chamber **22** are employed for obtaining the drilling data and transmitting the data to a drilling control unit, wherein the drilling data is transmitted via cables, ultrasonic wave, acoustic signals, or radio-frequency signals. In some embodiment, the sensor **24** may be supplied with power via cables or batteries in the sensing chamber **22**.

**[0040]** Another aspect of the present invention relates to a method of obtaining hydrocarbon by a drill apparatus including the measurement-while-drilling device, comprising: designing a predetermined drilling trajectory which leads to hydrocarbon to be produced; drilling a well bore with the drill apparatus comprising a measurement-while-drilling device based on the predetermined drilling trajectory; removing the drill apparatus from the well bore; and obtaining the hydrocarbon from the well bore.

**[0041]** The step of drilling a well bore with a drill apparatus comprising a measurement-while-drilling device comprises: obtaining drilling data with the measurement-while-drilling device; transmitting the drilling data to a drilling control unit; and calibrating a drilling direction of the drill apparatus based on the drilling data and the predetermined drilling trajectory.

**[0042]** In some embodiment, the step of transmitting the drilling data comprises transmitting via cables, ultrasonic wave, acoustic signals, or radio-frequency signals.

**[0043]** In some embodiment, the method further comprises encoding the drilling data before transmitting them.

**[0044]** Another aspect of the present invention further relates to a method for producing a measurement-while-drilling device, comprising: providing a base having a rotation axis, configured to be axially connected between a drill pipe and a drill bit of a drill apparatus and having a first and second end surfaces at the two axial ends thereof and a cylindrical peripheral side surface extending between the first and second end surfaces; forming at least one sensing chamber in the base which has an opening at at least one of the end surfaces; forming a passage in the base which is configured to allow liquid communication between the drill pipe and the drill bit; disposing at least one sensor in the sensing chamber from the opening of the sensing chamber; and sealing the sensing chamber on the at least one of the end surfaces.

**[0045]** In some embodiment, the method further comprises forming a first connecting part near the first end surface and forming a second connecting part near the second end surface, for connecting the base with the drill pipe and the drill bit of the drill apparatus.

**[0046]** Although some specific embodiments have been described as mentioned above, the skilled in the art understand that various modifications and variations may be made. Accordingly, it should be noted that the claims are intended to cover all the modifications and variations within the actual concepts and scopes of the present invention.

What is claimed is:

1. A measurement-while-drilling device, comprising:
  - a base having a rotation axis and configured to be axially coupled between a drill pipe and a drill bit, the base having a first and second peripheral end surface at each axial end thereof and a cylindrical peripheral side surface extending between the first and second peripheral end surfaces, the base defining at least one sensing chamber which opens onto at least one of the peripheral end surfaces, and a passage which is configured to allow fluid communication between the drill pipe and the drill bit;
  - at least one sensor disposed within the sensing chamber; and
  - a sealing member configured to hermetically seal the sensing chamber on the least one of the peripheral end surfaces; wherein

the sensor and the sensing chamber are configured to obtain and transmit drilling data to a surface drill control unit.

2. The measurement-while-drilling device according to claim 1, wherein the at least one of the peripheral end surfaces is a planar surface at an angle to the cylindrical peripheral side surface.

3. The measurement-while-drilling device according to claim 1, wherein the sealing member comprises a cover on the at least one of the peripheral end surfaces, and a sealing gasket disposed between the cover and the at least one of the peripheral end surfaces.

4. The measurement-while-drilling device according to claim 1, wherein dimensions of the sensing chamber substantially conform to a radius of curvature of the cylindrical peripheral side surface.

5. The measurement-while-drilling device according to claim 1, wherein the base has a first connecting portion adjacent to the first peripheral end surface and a second connecting portion adjacent to the second peripheral end surface, for coupling with the drill pipe and the drill bit, respectively.

6. The measurement-while-drilling device according to claim 5, wherein the first connecting portion comprises a convex portion with outer threads, protruding from the first peripheral end surface, and the second connecting portion comprises a concave portion with inner threads, inwardly concaved from the second peripheral end surface.

7. The measurement-while-drilling device according to claim 1, wherein the sensor comprises a strain gauge, a 3D accelerometer or a combination thereof.

8. The measurement-while-drilling device according to claim 7, wherein the strain gauge comprises a first, second and third strain component mounted on an inner wall of the sensing chamber along three different directions, respectively.

9. The measurement-while-drilling device according to claim 8, wherein the first, second and third strain components are mounted on aside of the inner wall of the chamber which is close to the cylindrical peripheral side surface.

10. The measurement-while-drilling device according to claim 8, wherein the first and second strain components are disposed symmetrically about the third strain component.

11. The measurement-while-drilling device according to claim 10, wherein an angle between the first strain component and third strain component is about 45 degree.

12. The measurement-while-drilling device according to claim 1, comprising one or more pairs of sensors, each comprising a 3D accelerometer, wherein the 3D accelerometers of each pair of sensors disposed symmetrically about the rotation axis.

13. The measurement-while-drilling device according to claim 1, wherein the drilling data is transmitted via cable, ultrasound, sonic signal, or radio frequency signal.

14. A method, comprising:

- designing a predetermined drilling trajectory which leads to hydrocarbon to be produced;
- drilling a well bore with a drilling device comprising a measurement-while-drilling device based on the predetermined drilling trajectory, comprising:
  - obtaining drilling data with the measurement-while-drilling device,
  - transmitting the drilling data to a surface drill control unit, and

calibrating a drilling direction of the drilling device based on the drilling data and the predetermined drilling trajectory;

removing the drilling device from the well bore; and  
obtaining the hydrocarbon from the well bore;

wherein the measurement-while-drilling device comprises a base having a rotation axis configured to be axially coupled between a drill pipe and a drill bit, the base having a first and second peripheral end surface at each axial end thereof and a cylindrical peripheral side surface extending between the first and second peripheral end surfaces, the base defining at least one sensing chamber which opens onto at least one of the peripheral end surfaces, and a passage which is configured to allow fluid communication between the drill pipe and the drill bit, at least one sensor disposed within the sensing chamber, and a sealing member configured to hermetically seal the sensing chamber on the least one of the peripheral end surfaces.

**15.** The method according to claim **14**, wherein transmitting the drilling data comprises transmitting the drilling data via cable, ultrasound, sonic signal, or radio frequency signal.

**16.** The method according to claim **14**, further comprising coding the drilling data before transmitting the drilling data.

**17.** A method for producing a measurement-while-drilling device, comprising:

providing a base having a first and second peripheral end surface at each axial end thereof and a cylindrical peripheral side surface extending between the first and second peripheral end surfaces;

forming at least one sensing chamber in the base which opens onto at least one of the peripheral end surfaces, and a passage which is configured to allow fluid communication between the drill pipe and the drill bit; disposing at least one sensor in the sensing chamber; and hermetically sealing the sensing chamber on the least one of the peripheral end surfaces.

**18.** The method according to claim **17**, further comprising forming a first connecting portion adjacent to the first peripheral end surface and a second connecting portion adjacent to the second peripheral end surface.

**19.** The method according to claim **18**, wherein the first connecting portion comprises a convex portion with outer threads, protruding from the first peripheral end surface, and the second connecting portion comprises a concave portion with inner threads, inwardly concaved from the second peripheral end surface.

\* \* \* \* \*