



US 20180051565A1

(19) **United States**

(12) **Patent Application Publication**
Bunker

(10) **Pub. No.: US 2018/0051565 A1**

(43) **Pub. Date: Feb. 22, 2018**

(54) **ENGINE COMPONENT WITH POROUS TRENCH**

F04D 29/32 (2006.01)

F02K 3/06 (2006.01)

(71) Applicant: **General Electric Company**,
Schenectady, NY (US)

(52) **U.S. Cl.**
CPC *F01D 5/183* (2013.01); *F01D 5/28*

(72) Inventor: **Ronald Scott Bunker**, Placitas, NM
(US)

(2013.01); *F01D 9/041* (2013.01); *F01D*

25/12 (2013.01); *F04D 29/542* (2013.01);

F04D 29/582 (2013.01); *F05D 2300/514*

(2013.01); *F02K 3/06* (2013.01); *F05D*

2220/30 (2013.01); *F05D 2240/121* (2013.01);

F05D 2240/303 (2013.01); *F05D 2260/203*

(2013.01); *F05D 2260/232* (2013.01); *F04D*

29/324 (2013.01)

(21) Appl. No.: **15/238,150**

(22) Filed: **Aug. 16, 2016**

Publication Classification

(51) **Int. Cl.**

F01D 5/18 (2006.01)

F01D 5/28 (2006.01)

F01D 9/04 (2006.01)

F01D 25/12 (2006.01)

F04D 29/54 (2006.01)

F04D 29/58 (2006.01)

(57)

ABSTRACT

An apparatus and method for cooling an engine component, such as an airfoil, including a wall to separate a hot flow from a cooling fluid flow. The component can include at least one trench disposed in a hot surface. The trench can be fed with the cooling fluid flow to cool the engine component along the hot surface with the cooling fluid flow.

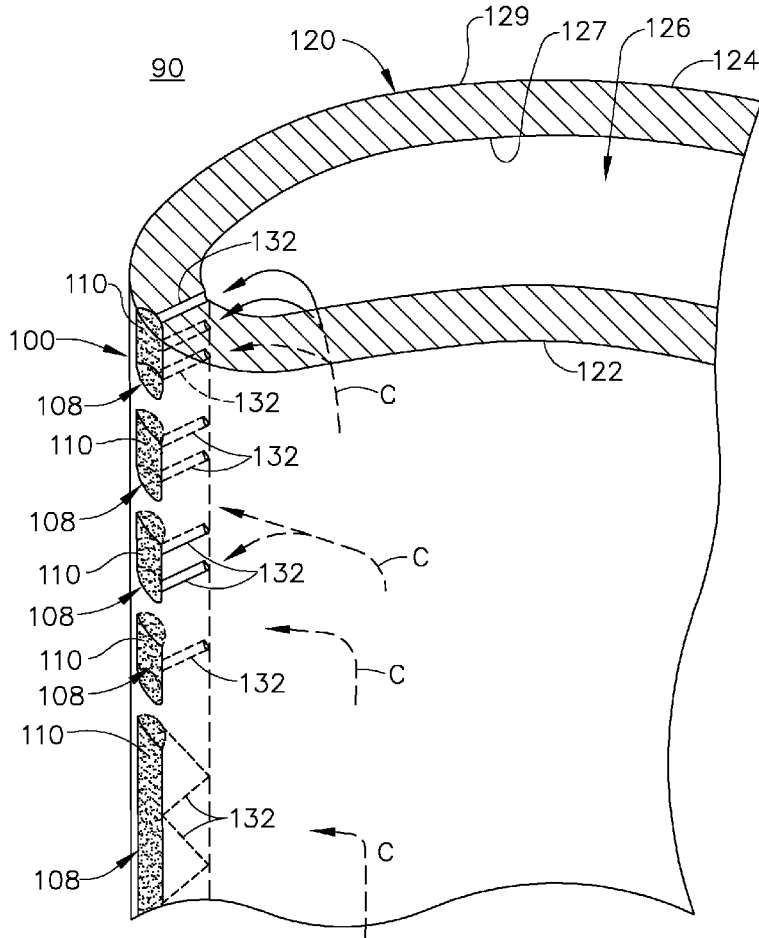

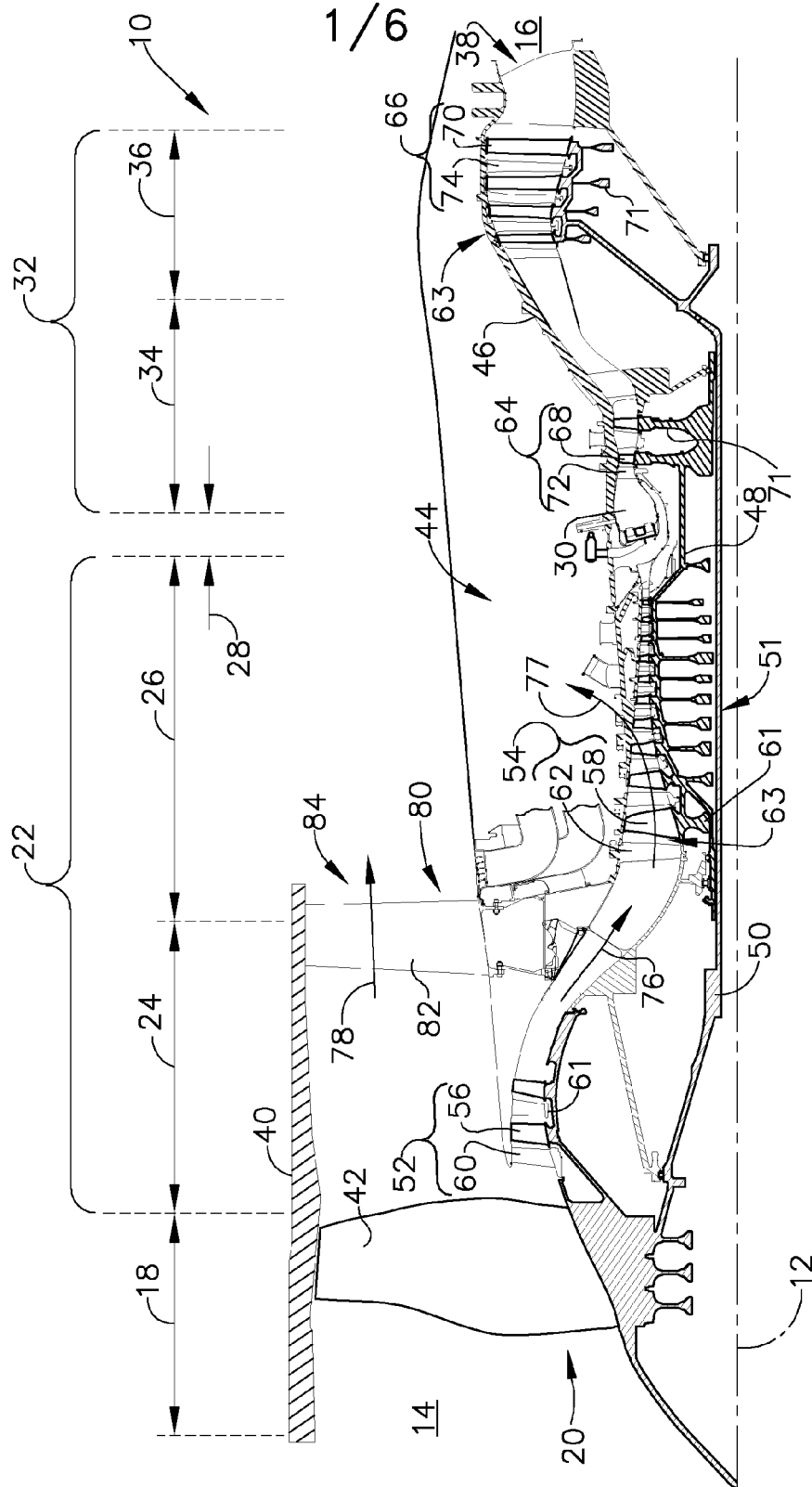

FIG. 1

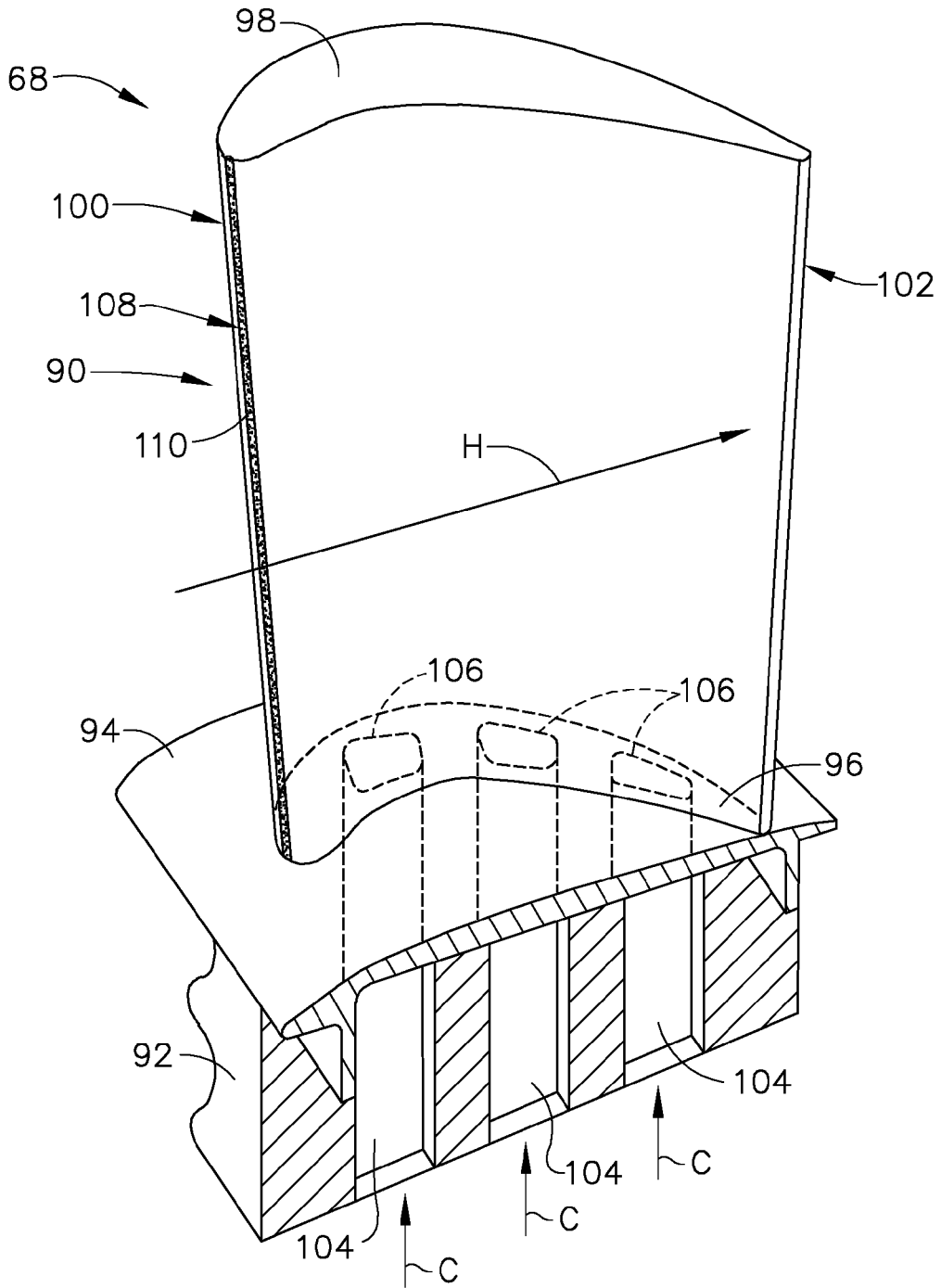

FIG. 2

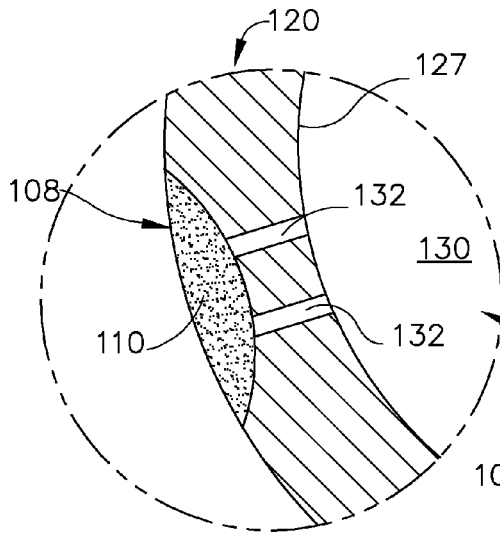

FIG. 4

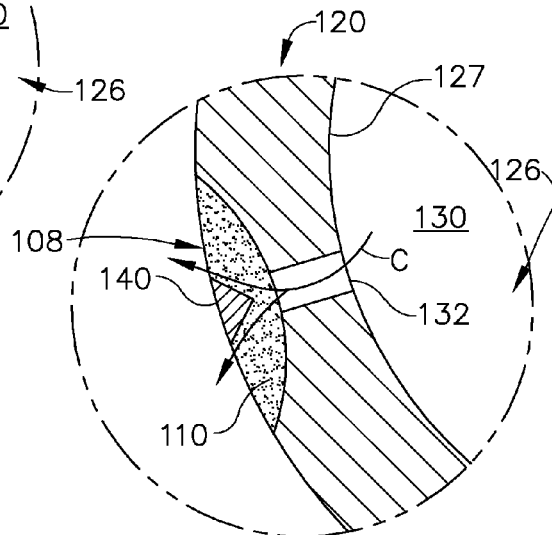

FIG. 5

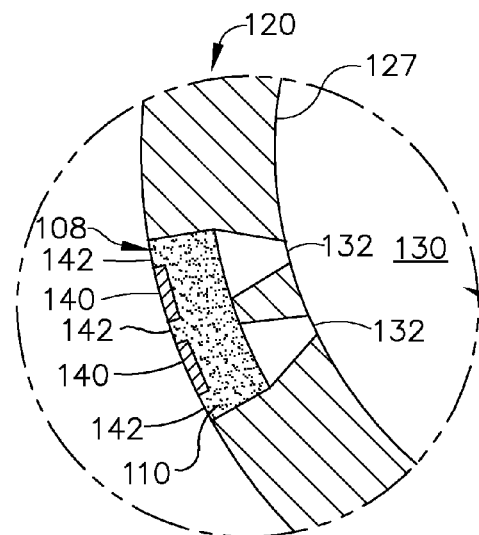

FIG. 6

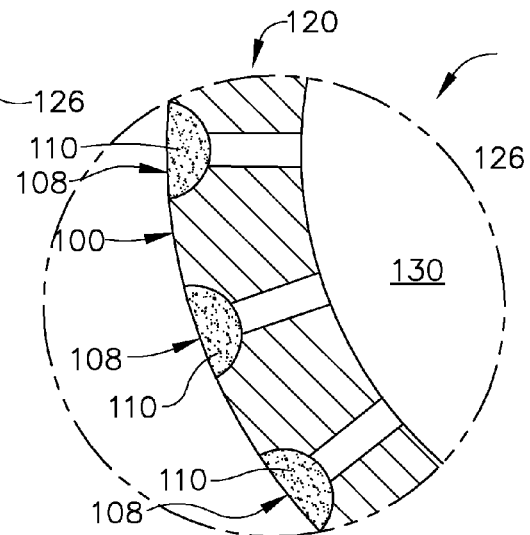

FIG. 7

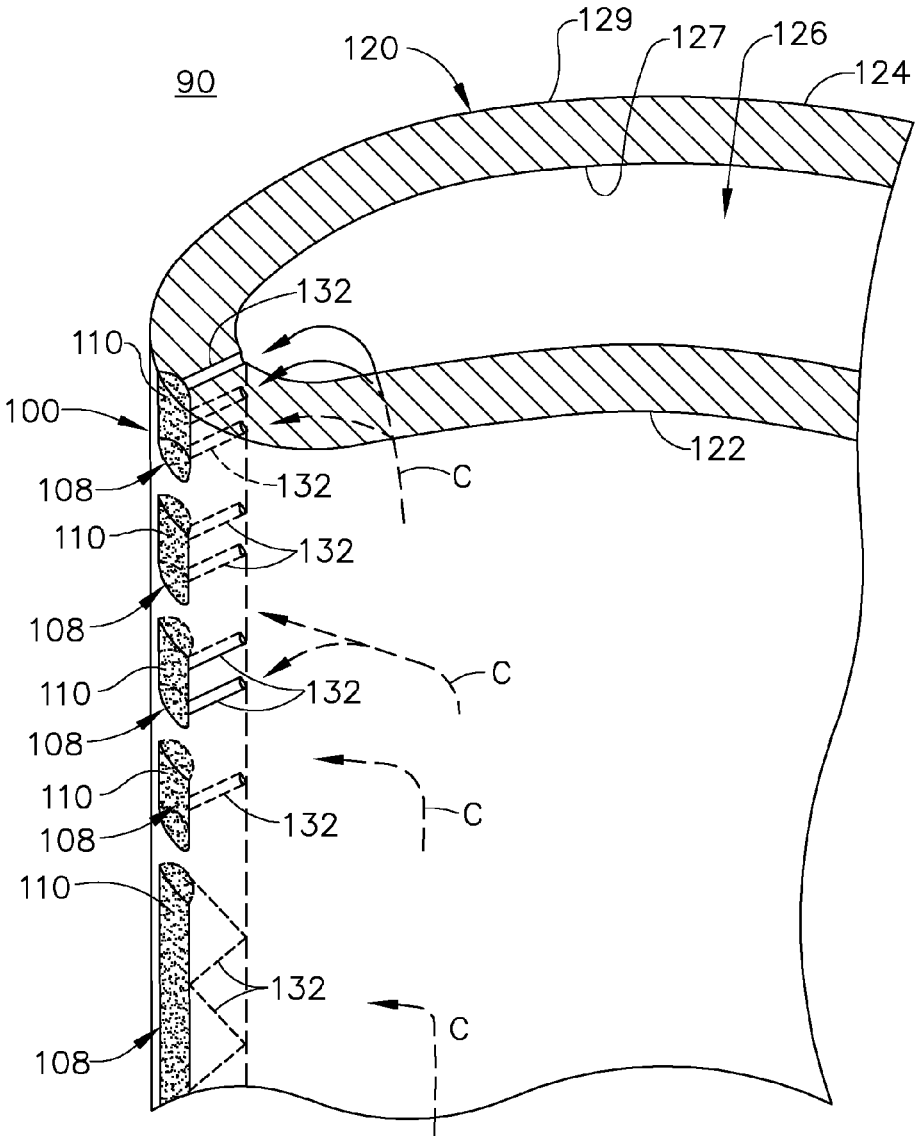

FIG. 8

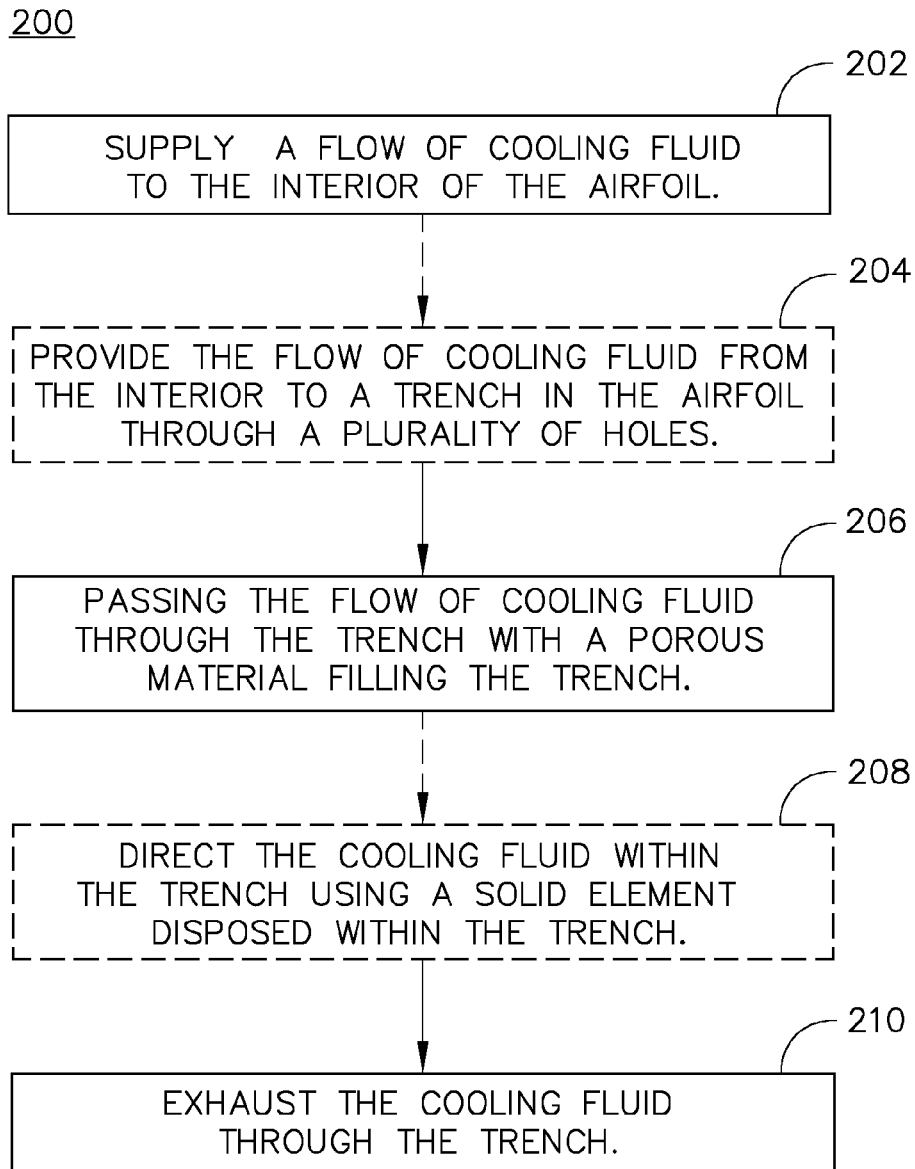

FIG. 9

ENGINE COMPONENT WITH POROUS TRENCH

BACKGROUND OF THE INVENTION

[0001] Turbine engines, and particularly gas or combustion turbine engines, are rotary engines that extract energy from a flow of combusted gases passing through the engine onto a multitude of rotating turbine blades.

[0002] Turbine engines for aircraft, such as gas turbine engines, are often designed to operate at high temperatures to maximize engine efficiency, so cooling of certain engine components, such as the high pressure turbine and the low pressure turbine, can be beneficial. Typically, cooling is accomplished by ducting cooler air from the high and/or low pressure compressors to the engine components that require cooling. Temperatures in the high pressure turbine are around 1000° C. to 2000° C. and the cooling air from the compressor is around 500° C. to 700° C. While the compressor air is a high temperature, it is cooler relative to the turbine air, and can be used to cool the turbine.

[0003] Contemporary turbine components, such as blades, can include one or more interior cooling circuits for routing the cooling air through the component to cool different portions of the component, and can include dedicated cooling circuits for cooling different portions of the component, such as the leading edge, trailing edge, or tip of the blade.

BRIEF DESCRIPTION OF THE INVENTION

[0004] In one aspect, embodiments of the invention relate to a component for a turbine engine, which generates a hot flow and provides a cooling fluid flow. The component includes a wall defining an interior and separating the hot flow from the cooling fluid flow and having a hot surface along with the hot flow and a cooling surface facing the cooling fluid flow. The component further includes at least one trench disposed in the hot surface and at least one hole in the wall fluidly coupling the interior to the trench. A porous material at least partially fills the trench.

[0005] In another aspect, embodiments of the invention relate to an airfoil for a turbine engine including a wall bounding an interior and defining a pressure side and a suction side extending chord-wise between a leading edge and a trailing edge, and extending in the span-wise direction between the root and the tip. The airfoil further includes at least one trench extending in the span-wise direction near or along the leading edge and at least one hole in the wall fluidly coupling the interior to the trench. A porous material at least partially fills the trench.

[0006] In yet another aspect, embodiments of the invention relate to a method of providing a cooling fluid along a trench disposed along a leading edge of an airfoil for a turbine engine. The method comprises (1) supplying a flow of cooling fluid to the interior of the airfoil; (2) passing the flow of cooling fluid through a porous material located in the trench; and (3) exhausting the cooling fluid through the trench.

BRIEF DESCRIPTION OF THE DRAWINGS

[0007] In the drawings:

[0008] FIG. 1 is a schematic cross-sectional diagram of a turbine engine for an aircraft.

[0009] FIG. 2 is a perspective view of an engine component of the turbine engine of FIG. 1 illustrated as an airfoil.

[0010] FIG. 3 is a cross-sectional view of the airfoil of FIG. 2 including a trench along the leading edge according to an embodiment of the invention.

[0011] FIG. 4 is an enlarged view of the leading edge of the airfoil of FIG. 2 having two holes coupling an interior of the airfoil to the trench according to an embodiment of the invention.

[0012] FIG. 5 is an enlarged view of the leading edge of the airfoil of FIG. 2 including a solid element disposed in the trench according to an embodiment of the invention.

[0013] FIG. 6 is an enlarged view of the leading edge of the airfoil of FIG. 2 illustrating alternative geometries for the solid element, the trench, and the holes according to an embodiment of the invention.

[0014] FIG. 7 is an enlarged view of a leading edge of an airfoil of the turbine engine of FIG. 1 illustrating three spaced trenches along the leading edge according to an embodiment of the invention.

[0015] FIG. 8 is a perspective view of a leading edge of an airfoil of the turbine engine of FIG. 1 illustrating multiple trenches in span-wise arrangement coupled to an interior of the airfoil.

[0016] FIG. 9 is a flow chart illustrating a method of providing a cooling fluid along a trench disposed along a leading edge of an airfoil.

DESCRIPTION OF EMBODIMENTS OF THE INVENTION

[0017] The described embodiments of the present invention are directed to a trench having porous material for cooling an airfoil for a gas turbine engine. For purposes of illustration, the present invention will be described with respect to the airfoil for an aircraft gas turbine engine. It will be understood, however, that the invention is not so limited and may have general applicability within an engine, including compressors, as well as in non-aircraft applications, such as other mobile applications and non-mobile industrial, commercial, and residential applications. Additionally, the aspects will have applicability outside of an airfoil, and can extend to any engine component requiring cooling, such as a blade, vane, shroud, or a combustion liner in non-limiting examples.

[0018] As used herein, the term “forward” or “upstream” refers to moving in a direction toward the engine inlet, or a component being relatively closer to the engine inlet as compared to another component. The term “aft” or “downstream” used in conjunction with “forward” or “upstream” refers to a direction toward the rear or outlet of the engine or being relatively closer to the engine outlet as compared to another component.

[0019] Additionally, as used herein, the terms “radial” or “radially” refer to a dimension extending between a center longitudinal axis of the engine and an outer engine circumference.

[0020] All directional references (e.g., radial, axial, proximal, distal, upper, lower, upward, downward, left, right, lateral, front, back, top, bottom, above, below, vertical, horizontal, clockwise, counterclockwise, upstream, downstream, forward, aft, etc.) are only used for identification purposes to aid the reader's understanding of the present invention, and do not create limitations, particularly as to the position, orientation, or use of the invention. Connection references (e.g., attached, coupled, connected, and joined) are to be construed broadly and can include intermediate

members between a collection of elements and relative movement between elements unless otherwise indicated. As such, connection references do not necessarily infer that two elements are directly connected and in fixed relation to one another. The exemplary drawings are for purposes of illustration only and the dimensions, positions, order and relative sizes reflected in the drawings attached hereto can vary.

[0021] FIG. 1 is a schematic cross-sectional diagram of a gas turbine engine 10 for an aircraft. The engine 10 has a generally longitudinally extending axis or centerline 12 extending forward 14 to aft 16. The engine 10 includes, in downstream serial flow relationship, a fan section 18 including a fan 20, a compressor section 22 including a booster or low pressure (LP) compressor 24 and a high pressure (HP) compressor 26, a combustion section 28 including a combustor 30, a turbine section 32 including a HP turbine 34, and a LP turbine 36, and an exhaust section 38.

[0022] The fan section 18 includes a fan casing 40 surrounding the fan 20. The fan 20 includes a plurality of fan blades 42 disposed radially about the centerline 12. The HP compressor 26, the combustor 30, and the HP turbine 34 form a core 44 of the engine 10, which generates combustion gases. The core 44 is surrounded by core casing 46, which can be coupled with the fan casing 40.

[0023] A HP shaft or spool 48 disposed coaxially about the centerline 12 of the engine 10 drivingly connects the HP turbine 34 to the HP compressor 26. A LP shaft or spool 50, which is disposed coaxially about the centerline 12 of the engine 10 within the larger diameter annular HP spool 48, drivingly connects the LP turbine 36 to the LP compressor 24 and fan 20. The spools 48, 50 are rotatable about the engine centerline and couple to a plurality of rotatable elements, which can collectively define a rotor 51.

[0024] The LP compressor 24 and the HP compressor 26 respectively include a plurality of compressor stages 52, 54, in which a set of compressor blades 56, 58 rotate relative to a corresponding set of static compressor vanes 60, 62 (also called a nozzle) to compress or pressurize the stream of fluid passing through the stage. In a single compressor stage 52, 54, multiple compressor blades 56, 58 can be provided in a ring and can extend radially outwardly relative to the centerline 12, from a blade platform to a blade tip, while the corresponding static compressor vanes 60, 62 are positioned upstream of and adjacent to the rotating blades 56, 58. It is noted that the number of blades, vanes, and compressor stages shown in FIG. 1 were selected for illustrative purposes only, and that other numbers are possible.

[0025] The blades 56, 58 for a stage of the compressor can be mounted to a disk 61, which is mounted to the corresponding one of the HP and LP spools 48, 50, with each stage having its own disk 61. The vanes 60, 62 for a stage of the compressor can be mounted to the core casing 46 in a circumferential arrangement.

[0026] The HP turbine 34 and the LP turbine 36 respectively include a plurality of turbine stages 64, 66, in which a set of turbine blades 68, 70 are rotated relative to a corresponding set of static turbine vanes 72, 74 (also called a nozzle) to extract energy from the stream of fluid passing through the stage. In a single turbine stage 64, 66, multiple turbine blades 68, 70 can be provided in a ring and can extend radially outwardly relative to the centerline 12, from a blade platform to a blade tip, while the corresponding static turbine vanes 72, 74 are positioned upstream of and adjacent to the rotating blades 68, 70. It is noted that the

number of blades, vanes, and turbine stages shown in FIG. 1 were selected for illustrative purposes only, and that other numbers are possible.

[0027] The blades 68, 70 for a stage of the turbine can be mounted to a disk 71, which is mounted to the corresponding one of the HP and LP spools 48, 50, with each stage having a dedicated disk 71. The vanes 72, 74 for a stage of the compressor can be mounted to the core casing 46 in a circumferential arrangement.

[0028] Complementary to the rotor portion, the stationary portions of the engine 10, such as the static vanes 60, 62, 72, 74 among the compressor and turbine section 22, 32 are also referred to individually or collectively as a stator 63. As such, the stator 63 can refer to the combination of non-rotating elements throughout the engine 10.

[0029] In operation, the airflow exiting the fan section 18 is split such that a portion of the airflow is channeled into the LP compressor 24, which then supplies pressurized airflow 76 to the HP compressor 26, which further pressurizes the air. The pressurized airflow 76 from the HP compressor 26 is mixed with fuel in the combustor 30 and ignited, thereby generating combustion gases. Some work is extracted from these gases by the HP turbine 34, which drives the HP compressor 26. The combustion gases are discharged into the LP turbine 36, which extracts additional work to drive the LP compressor 24, and the exhaust gas is ultimately discharged from the engine 10 via the exhaust section 38. The driving of the LP turbine 36 drives the LP spool 50 to rotate the fan 20 and the LP compressor 24.

[0030] A portion of the pressurized airflow 76 can be drawn from the compressor section 22 as bleed air 77. The bleed air 77 can be drawn from the pressurized airflow 76 and provided to engine components requiring cooling. The temperature of pressurized airflow 76 entering the combustor 30 is significantly increased. As such, cooling provided by the bleed air 77 is necessary for operating of such engine components in the heightened temperature environments.

[0031] A remaining portion of the airflow 78 bypasses the LP compressor 24 and engine core 44 and exits the engine assembly 10 through a stationary vane row, and more particularly an outlet guide vane assembly 80, comprising a plurality of airfoil guide vanes 82, at the fan exhaust side 84. More specifically, a circumferential row of radially extending airfoil guide vanes 82 are utilized adjacent the fan section 18 to exert some directional control of the airflow 78.

[0032] Some of the air supplied by the fan 20 can bypass the engine core 44 and be used for cooling of portions, especially hot portions, of the engine 10, and/or used to cool or power other aspects of the aircraft. In the context of a turbine engine, the hot portions of the engine are normally downstream of the combustor 30, especially the turbine section 32, with the HP turbine 34 being the hottest portion as it is directly downstream of the combustion section 28. Other sources of cooling fluid can be, but are not limited to, fluid discharged from the LP compressor 24 or the HP compressor 26.

[0033] Referring now to FIG. 2, an engine component is shown in the form of an airfoil 90, which can be one of the turbine blades 68 of the engine 10 of FIG. 1, for example. Alternatively, the engine component can include a vane, a shroud, or a combustion liner in non-limiting examples, or any other engine component that can require or utilize cooling, such as film cooling. The airfoil 90 couples to a dovetail 92 and a platform 94. The airfoil 90 extends radially

between a root **96** and a tip **98** defining a span-wise direction. The airfoil **90** extends axially between a leading edge **100** and a trailing edge **102** defining a chord-wise direction. The dovetail **92** can be integral with the platform **94**, which can couple to the airfoil **90** at the root **96**. The dovetail **92** can be configured to mount to a turbine rotor disk on the engine **10**, for example. The platform **94** helps to contain the turbine airflow radially. The dovetail **92** includes at least one inlet passage **104**, shown as three inlet passages **104**, each extending through the dovetail **92** in fluid communication with the airfoil **90** at a passage outlet **106**. It should be appreciated that the dovetail **92** is shown in cross-section, such that the inlet passages **104** are housed within the dovetail **92**.

[0034] A trench **108** extends along the leading edge **100** from the root **96** to the tip **98**. It should be appreciated that the trench **108** can extend only partially between the root **96** and the tip **98**, and can be any length. A porous material **110** is disposed in the trench **108** and can fill the trench **108**, forming a continuous, arcuate surface along with the rest of the airfoil **90**.

[0035] The trench **108**, as well as any trench described herein, can be an elongated cavity formed in the airfoil **90**, extending in the span-wise direction, for example. It should be appreciated that the trench can extend in any direction, such as span-wise, chord-wise, radial, axial, tangential, circumferential, or any combination thereof in non-limiting examples, particularly for engine components other than an airfoil. The trench **108**, can include a length and a width. In one example, the ratio of length to width can be at least 2:1. It should be understood, however, that the trench can include other ratios of length to width. The trench **108** can be any shape, such as rectilinear shapes including rectangular. Alternative shapes can include curvilinear, square, circular, geometric, or unique, such as potentially a serpentine trench in non-limiting examples. The trench **108**, in one non-limiting example, can include a depth that is at least one-half of the width, or at least a 1:2 ratio of depth to width. It should be understood that any depth is contemplated. The cross-sectional profile of the trench **108** with the section defined in the direction of the depth, can include any shape, such as semicircular, square, rectangular, triangular, conic, arcuate, curvilinear, or rectilinear in non-limiting examples. It should be appreciated that the trench can be any combination of shapes and cross-sections as described herein.

[0036] The porous material **110** can be formed by additive manufacturing, while it is contemplated that the entire airfoil **90** can be formed by additive manufacturing. It should be appreciated that any portion of the airfoil **90** can be made by any known method including but not limited to, casting, machining, additive manufacturing, coating, or otherwise. The porous material **110** can define a porosity, being permeable by a volume of fluid, such as air. The porous material **110** can have a particular porosity to meter the flow of a fluid passing through the porous material **110** at a predetermined rate. It should be appreciated that additive manufacturing can be used to achieve a particular local porosity along the porous material **110**, as well as a consistent porosity across the entirety of the porous material **110**, as compared to traditional method of forming the porous material **110**. In alternative examples, the porous material **110** can be made of any of the methods described above, such that a porosity is defined. In one non-limiting example, the porous material

110 can be made of Ni, NiCrAlY, NiAl, or similar materials. The porous material **110** can further be made of a nickel foam, for example.

[0037] During operation of the gas turbine engine, a hot flow **H** is driven by the blade to generate thrust. A cooling fluid flow **C** is provided to the airfoil **90** for cooling. The cooling fluid flow **C** can be exhausted through the porous material **110** in the trench **108** to cool the leading edge **100** of the airfoil **90**.

[0038] Referring now to FIG. 3, a cross-sectional view of the airfoil **90** illustrates a wall **120** of the airfoil **90** including a pressure side **122** and a suction side **124** extending between the leading edge **100** and the trailing edge **102**. An interior **126** of the airfoil **90** is defined by the wall **120**. The cooling fluid flow **C** can be provided to the interior **126** defining a cooling surface **127** along the interior **126** of the airfoil **90**. The hot flow **H** can define a hot surface **129** along the exterior of the wall **120**. One or more internal ribs **128** separates the interior **126** into passages **130** extending in the span-wise direction. The passages **130** can define one or more cooling circuits throughout the airfoil **90**. Additionally, the cooling circuits can be further includes micro-circuits, sub-circuits, near wall cooling circuits, leading edge passages, trailing edge passages, pin fins, pin banks, additional passages, flow enhancers such as turbulators, or other structures which can define the cooling circuits in non-limiting examples.

[0039] A hole **132** is disposed in the wall **120** fluidly coupling the interior **126** to the trench **108**. The hole **132** can be a plurality of holes **132** extending along the leading edge **100** in the span-wise direction for coupling the interior **126** to the trench **108** at different radial locations along the airfoil **90**. Alternatively, the hole **132** can be an elongated slot, extending for at least a portion of the trench **108**.

[0040] In operation, the flow of cooling fluid **C** is provided from the interior **126** of the airfoil **90** to the hole **132**. As a plurality of holes **132**, the passage **130** adjacent the holes **132** can extend in the span-wise direction, providing the flow of cooling fluid **C** to the plurality of holes **132** in the span-wise direction. The cooling fluid **C** within the holes **132** flows to the trench **108** and spreads through the porous material **110**. From the porous material **110** in the trench **108**, the cooling fluid **C** can disperse along the hot surface **129** along or adjacent the trench **108**, operating as a cooling film along the hot surface **129**.

[0041] Referring to FIG. 4, another example of the airfoil **90** is illustrated having two holes **132** fluidly coupling the interior **126** to the trench **108**. The holes **132** as illustrated are at the same span-wise distance along the wall **120**, positioned radially next to one another. As such, a plurality of holes **132** can be arranged as parallel rows extending in the span-wise direction. The holes **132** in the rows can be radially aligned with one another or offset. While two adjacent holes **132** are illustrated, it should be appreciated that any number of holes **132** can be included, forming any number or rows or columns. Additional holes **132** can increase the flow rate of cooling fluid **C** provided to the trench **108** or can provide directionality of the flow of cooling fluid **C** to a particular portion of the trench **108**.

[0042] Referring now to FIG. 5 another example is illustrated having a solid element **140** disposed in the porous material **110** within the trench **108**. The solid element **140** can be formed in the porous material **110**, such as by additive manufacturing, similar to the porous material **110**, or can be

formed by any other method. Alternatively, the solid element **140** can be mounted within the porous material **110**. The solid element **140**, in one non-limiting example, can be an elongated member extending the length of the trench **108**, and can have a triangular profile. As such, the sides of the triangular shape can direct the cooling fluid **C** within the porous material **110** to the sides of the solid element **140**. Thus, the cooling fluid **C** can, for example, be separated toward the pressure side **122** and the suction side **124** of the airfoil **90** apart from the leading edge **100**. In another example, the solid elements **140** can be discrete conic members disposed in the porous material **110**, having the triangular profile as shown. Each discrete conic solid element **140** can be positioned at the outlet of the hole **132** to direct the flow of cooling fluid **C** toward the pressure and suction sides **122**, **124**, as well as radially above and below the solid element **140** along the trench **108**.

[0043] It should be appreciated that the solid element **140** can be any shape, or size, having any position within the trench **108** or porous material **110** for directing the flow of cooling fluid **C**. The solid element **140** can be a single element or multiple discrete elements. Furthermore, the solid element **140** can be made of a porous material. In such an example, the solid element **140** would have a lesser porosity than the porous material **110** within the trench **108** to direct the flow of cooling fluid **C** while permitting a portion of the cooling fluid **C** to pass through the solid element **140**.

[0044] Referring now to FIG. 6, another example is shown having a rectilinear trench **108** curved to follow the shape of the airfoil **90**. Two solid elements **140** are disposed in the trench **108** to define three outlets **142** from the porous material **110**. The holes **132** include an increasing cross-sectional area moving from the interior **126** toward the trench **108**. The increasing cross-sectional area can evenly disperse a flow of cooling fluid **C** throughout the trench **108** as well as operate to meter the flow of cooling fluid **C** from the interior **126**.

[0045] It should be understood that the trench **108**, holes **132**, and solid elements **140** as illustrated in FIG. 6 are exemplary. It should be further understood that the trench **108** can be any shape, extending at least partially in the span-wise direction, being linear, curvilinear, arcuate, adapted to follow the curve of the wall **120** of the airfoil **90**, and having any cross-sectional area, profile, or shape, such as semicircular, curvilinear, rectilinear, or arcuate, or any combination thereof. The trench **108** can be aligned along the leading edge **100**, or can be near or adjacent to the leading edge **100**. Furthermore, the trench **108** need not be linear in the span-wise direction, but can generally extend in the span-wise direction, curving or varying from span-wise or radial extension. Such an example could include a serpentine pattern for the trench **108**.

[0046] It should also be understood that the holes **132** are not limited as shown, and can include one or more holes **132**, such as multiple holes **132**, fluidly coupling the interior **126** to the trench **108**. The holes **132** can be organized in patterns, such as rows, columns, or clusters for example. The holes **132** can be any shape, such as circular or elliptical. In another example, the hole **132** can be a single slot extending along at least a portion of the trench **108**. The holes **132** can be angled, for example, such as extending in a combined axial and radial direction, or in three-dimensional space. The

holes **132** can further meter the flow of cooling fluid **C**, such as having a metering portion, or increasing or decreasing cross-sectional areas.

[0047] It should be further understood that the solid elements **140** can include any shape, size, geometry, pattern or organization to direct a flow of cooling fluid within the trench **108**. In the case of multiple solid elements **140**, different solid elements **140** can vary among one another based upon the local airfoil **90** cooling needs or the particular local cooling flow **C**.

[0048] Further still, the porous material **110**, can be a structured porous material or a random porous material, or any combination thereof. A structured porous material includes a determinative porosity throughout the material, which can have particular local increases or decreases in porosity to meter a flow of fluid passing through the structured porous material. Such local porosities can be determined and controlled during manufacture. Additive manufacturing can be used to form a structured porous material, in one non-limiting example. Alternatively, the porous materials can have a random porosity. The random porosity can be adapted to have a porosity as the average porosity over an area of the porous material, having discrete variable porosities that are random. A random porous material can be made from a nickel foam, in one non-limiting example.

[0049] Referring now to FIG. 7, another example shows that the airfoil **90** can include multiple trenches **108** organized in chord-wise alignment, such as three parallel trenches **108**. The trenches **108** can be linear or non-linear. The trenches **108** can be aligned symmetrically with the leading edge **100**, such that the middle trench **108** extends along the leading edge **100**, or can be offset, as particular cooling needs of the airfoil **90** can dictate.

[0050] It should be appreciated that each trench, such as the exemplary trenches in FIGS. 3-7, can include an apex as the point of the trench nearest to the interior **126** of the airfoil **90**. In one example, the hole **132** can be positioned at the apex of the trench. Furthermore, the hole **132** can be aligned at the center of the apex, or partially offset from the apex to provide a deterministic flow into the trench.

[0051] Referring now to FIG. 8, another example shows the airfoil **90** having multiple discrete trenches **108** organized in the span-wise direction. The trench **108** need not extend fully in the span-wise direction, and can discretely extend radially along the airfoil **90** to define multiple trenches **108**. The multiple trenches **108** can be tailored to the local cooling needs of the airfoil **90**, having more or less holes **132** feeding the particular trench **108** to provide for increased or decreased cooling flows **C**. Additionally, the trenches **108**, holes **132**, or solid elements **140** can vary among trenches **108** to define a particular local flow based upon the local cooling needs of the airfoil **90**. Furthermore, it is contemplated that the trenches **108** are used in combination with film holes or other cooling structures.

[0052] Referring now to FIG. 9, a method **200** of providing a cooling fluid along a trench disposed along a leading edge of an airfoil for a turbine engine can include (1) supplying a flow of cooling fluid to an interior of the airfoil; (2) passing at least a portion of the flow of cooling fluid through the trench with a porous material filling the trench; and (3) exhausting the cooling fluid through the trench.

[0053] At **202**, the method **200** includes supplying a flow of cooling fluid **C** to the interior **126** of the airfoil **90**, which can include providing the cooling fluid **C** through the inlet

passages **104** as shown in FIG. 2, for example. At **204**, the method **200** can optionally include providing the flow of cooling fluid C from the interior **126** to the trench **108** in the airfoil **90** through a plurality of holes, which can be the holes **132** as described in FIGS. 3-8, fluidly coupling the interior **126** to the trench **108**.

[0054] At **206**, the method **200** includes passing the flow of cooling fluid C through the trench **108** with a porous material **110** filling the trench **108**, such as the porous material **110** shown in FIGS. 3-8. The porous material **110** can be a structured porous material, having a particular deterministic porous structure to define local porosities to affect local flows. It is also contemplated that the porous material has a random porosity.

[0055] At **208**, optionally, the method **200** can include directing the cooling fluid flow C within the trench **108** using a solid element **140** disposed within the trench **108**. Such solid elements **140** can be those seen in FIGS. 5-6 and can be shaped to particularly direct the cooling fluid flow C.

[0056] At **210**, the method **200** can include exhausting the cooling fluid flow C through the trench **108**. Such exhausted flow can be used as a cooling film along the hot surface **129** to cool the airfoil **90** or prevent excessive heat aggregation within the wall **120** of the airfoil **90**, particularly along the leading edge **100**.

[0057] It should be appreciated that while the description is directed toward a leading edge of the airfoil, the concepts as described herein can have equal applicability in additional engine components, such as a vane, shroud, or combustion liner in non-limiting examples, and the trench can be formed in any region of any engine component or airfoil requiring cooling, such as regions typically requiring film cooling holes or multi-bore cooling.

[0058] It should be further appreciated that the trench **108** having the porous material **110** can provide for improved film cooling, such as providing improved directionality, metering, or local flow rates. Additionally, the porous material included in the trench **108** can further improve the film cooling to an entire region beyond just the areas local to the film holes.

[0059] It should be further appreciated that application of the disclosed design is not limited to turbine engines with fan and booster sections, but is applicable to turbojets and turbo engines as well.

[0060] This written description uses examples to disclose the invention, including the best mode, and also to enable any person skilled in the art to practice the invention, including making and using any devices or systems and performing any incorporated methods. The patentable scope of the invention is defined by the claims, and may include other examples that occur to those skilled in the art. Such other examples are intended to be within the scope of the claims if they have structural elements that do not differ from the literal language of the claims, or if they include equivalent structural elements with insubstantial differences from the literal languages of the claims.

What is claimed is:

1. A component for a turbine engine, which generates a hot flow and provides a cooling fluid flow, the component comprising:

a wall defining an interior and separating the hot flow from the cooling fluid flow and having a hot surface facing the hot flow and a cooling surface facing the cooling fluid flow;

at least one trench disposed in the hot surface;
at least one hole in the wall fluidly coupling the interior to the trench; and

a porous material at least partially filling the trench.

2. The component of claim **1** wherein the at least one trench includes multiple trenches.

3. The component of claim **2** wherein the multiple trenches are separate from each other.

4. The component of claim **3** wherein the multiple trenches are parallel to each other.

5. The component of claim **3** wherein the multiple trenches are arranged in a row.

6. The component of claim **3** wherein the multiple trenches include multiple discrete trenches.

7. The component of claim **6** wherein the multiple discrete trenches are arranged in one of a row or parallel to one another.

8. The component of claim **7** wherein the trench includes an arcuate profile defining an apex and the at least one hole is disposed on the apex.

9. The component of claim **1** wherein the at least one hole includes multiple holes.

10. The component of claim **9** wherein the multiples holes are arranged in a row.

11. The component of claim **1** further comprising a solid element extending at least partially along the trench.

12. The component of claim **11** wherein the solid element is shaped to direct a flow of cooling fluid passing through the porous material.

13. An airfoil for a turbine engine, the airfoil comprising:
a wall bounding an interior and defining a pressure side and a suction side extending chord-wise between a leading edge and a trailing edge and extending in a span-wise direction between a root and a tip;

at least one trench extending in the span-wise direction near or along the leading edge;

at least one hole in the wall fluidly coupling the interior to the at least one trench; and

a porous material at least partially filling the trench.

14. The airfoil of claim **13** wherein the at least one trench includes multiple trenches spaced about the leading edge.

15. The airfoil of claim **14** wherein the multiple trenches are separate from each other.

16. The airfoil of claim **15** wherein the multiple trenches are parallel to each other.

17. The airfoil of claim **15** wherein the multiple trenches are arranged in a row.

18. The airfoil of claim **15** wherein the multiple trenches include multiple discrete trenches.

19. The airfoil of claim **18** wherein the multiple discrete trenches are arranged in one of a row or parallel to one another.

20. The airfoil of claim **13** wherein the trench includes an arcuate profile defining an apex and the at least one hole is disposed at the apex.

21. The airfoil of claim **13** wherein the at least one hole includes multiple holes arranged in at least one row.

22. The airfoil of claim **13** further comprising solid element extending at least partially along the trench.

23. A method of providing a flow of cooling fluid along a trench disposed along a component for a turbine engine, the method comprising:

supplying the flow of cooling fluid to an interior of the component;

passing at least a portion of the flow of cooling fluid through a porous material located in the trench; and exhausting the flow of cooling fluid through the trench.

24. The method of claim **23** wherein the component is an airfoil with the trench disposed along the leading edge of the airfoil.

25. The method of claim **23** further comprising directing the flow of cooling fluid using a solid element disposed in the trench.

26. The method of claim **23** further comprising providing the flow of cooling fluid from the interior to the trench through a plurality of holes.

* * * * *