



US 20220071197A1

(19) **United States**

(12) **Patent Application Publication**
HASSANEIN et al.

(10) **Pub. No.: US 2022/0071197 A1**
(43) **Pub. Date: Mar. 10, 2022**

(54) **SYSTEMS AND METHODS FOR EX-VIVO ORGAN CARE**

Nov. 12, 2015, now Pat. No. 10,314,303, which is a division of application No. 11/245,957, filed on Oct. 7, 2005, now Pat. No. 9,215,867.

(71) Applicant: **TransMedics, Inc.**, Andover, MA (US)

(60) Provisional application No. 60/725,168, filed on Oct. 6, 2005, provisional application No. 60/694,971, filed on Jun. 28, 2005, provisional application No. 60/616,835, filed on Oct. 7, 2004.

(72) Inventors: **Waleed H. HASSANEIN**, North Andover, MA (US); **Richard BRINGHAM**, North Andover, MA (US); **Giovanni CECERE**, Needham, MA (US); **Tamer I. KHAYAL**, North Andover, MA (US); **Ronald TAYLOR, JR.**, Chester, NH (US); **Hossam ALGAMIL**, Scranton, PA (US)

Publication Classification

(51) **Int. Cl.**
A01N 1/02 (2006.01)
(52) **U.S. Cl.**
CPC *A01N 1/0242* (2013.01); *A01N 1/0247* (2013.01); *A01N 1/02* (2013.01); *A01N 1/0226* (2013.01)

(21) Appl. No.: **17/530,037**

(22) Filed: **Nov. 18, 2021**

Related U.S. Application Data

(57) **ABSTRACT**

(60) Continuation of application No. 16/396,059, filed on Apr. 26, 2019, now Pat. No. 11,191,263, which is a continuation of application No. 14/939,845, filed on

The invention provides, in various embodiments, systems, devices and methods relating to ex-vivo organ care. In certain embodiments, the invention relates to maintaining an organ ex-vivo at near-physiologic conditions.

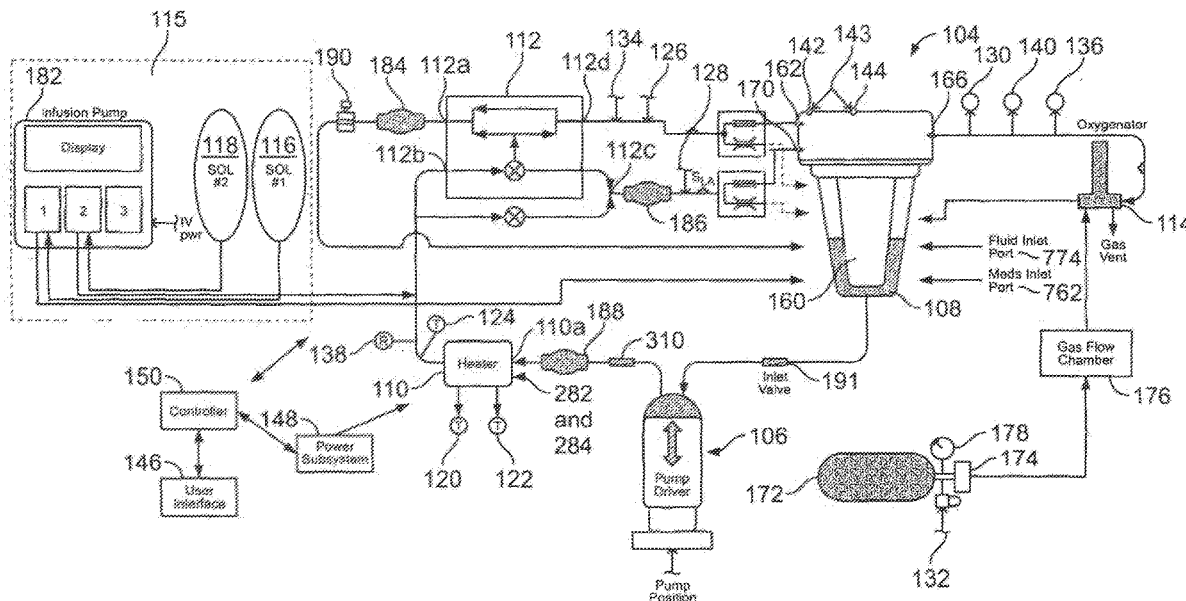

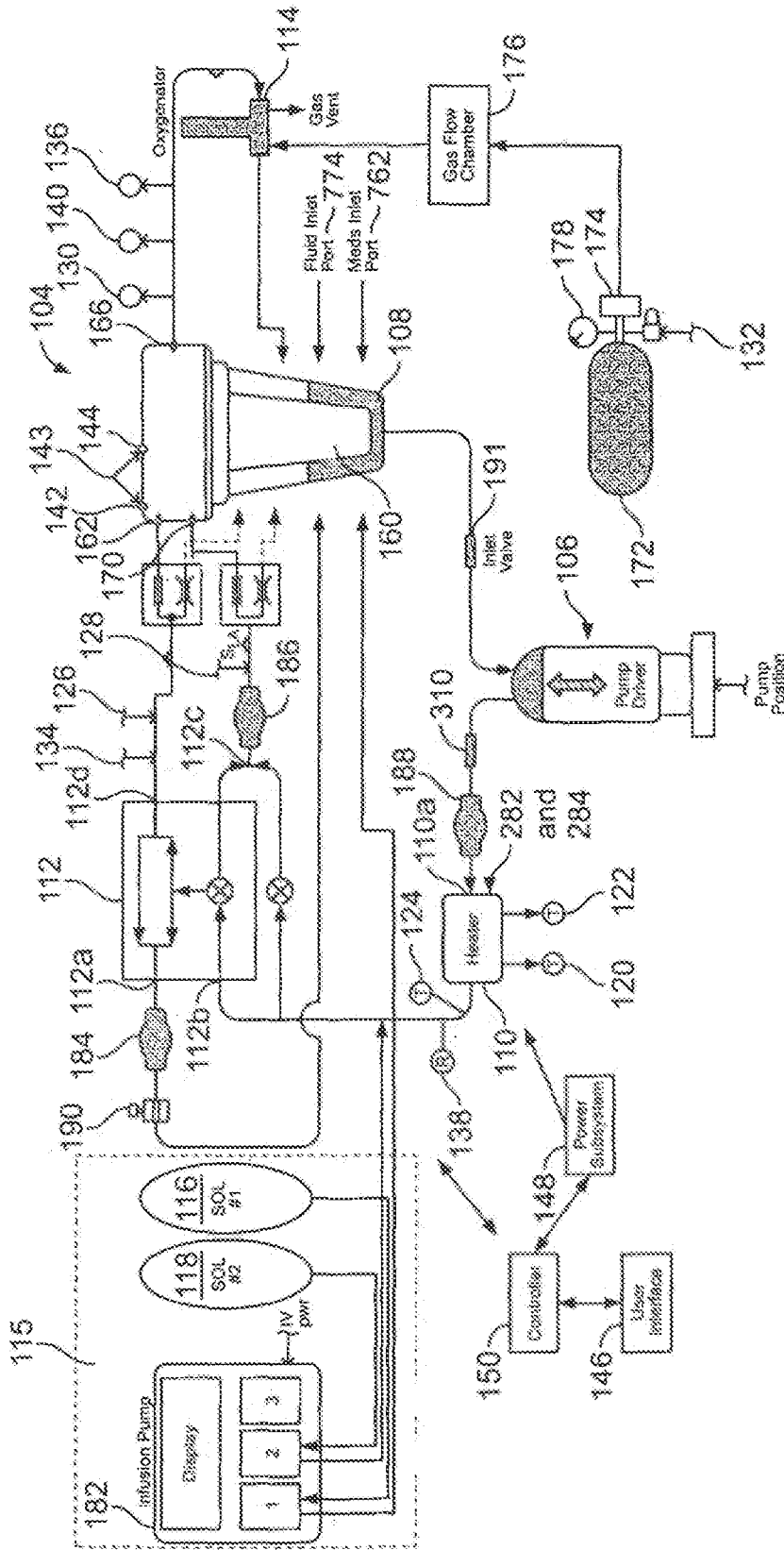

FIG. 1

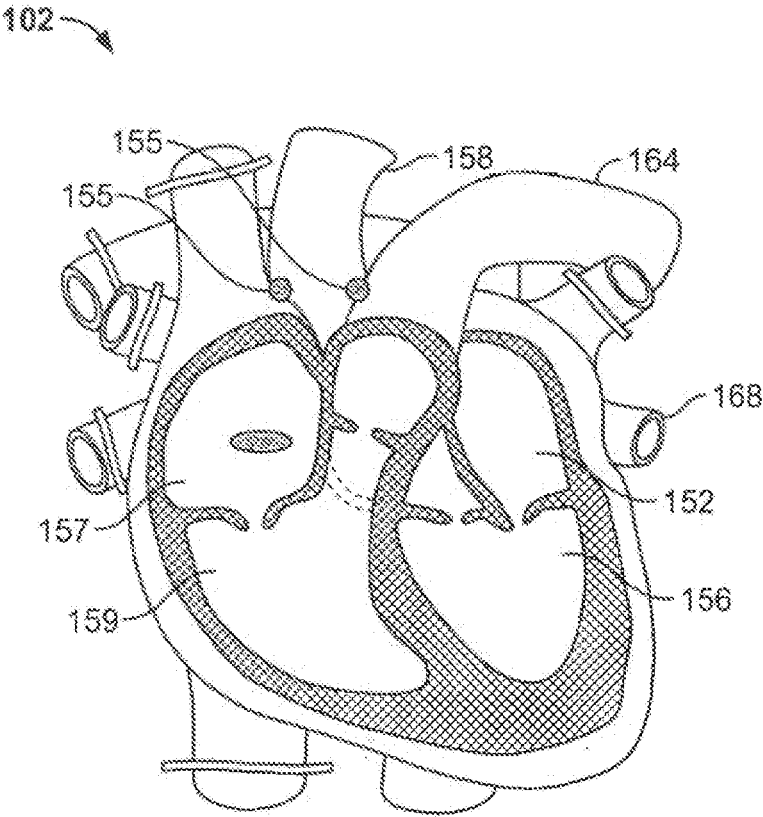

FIG. 2

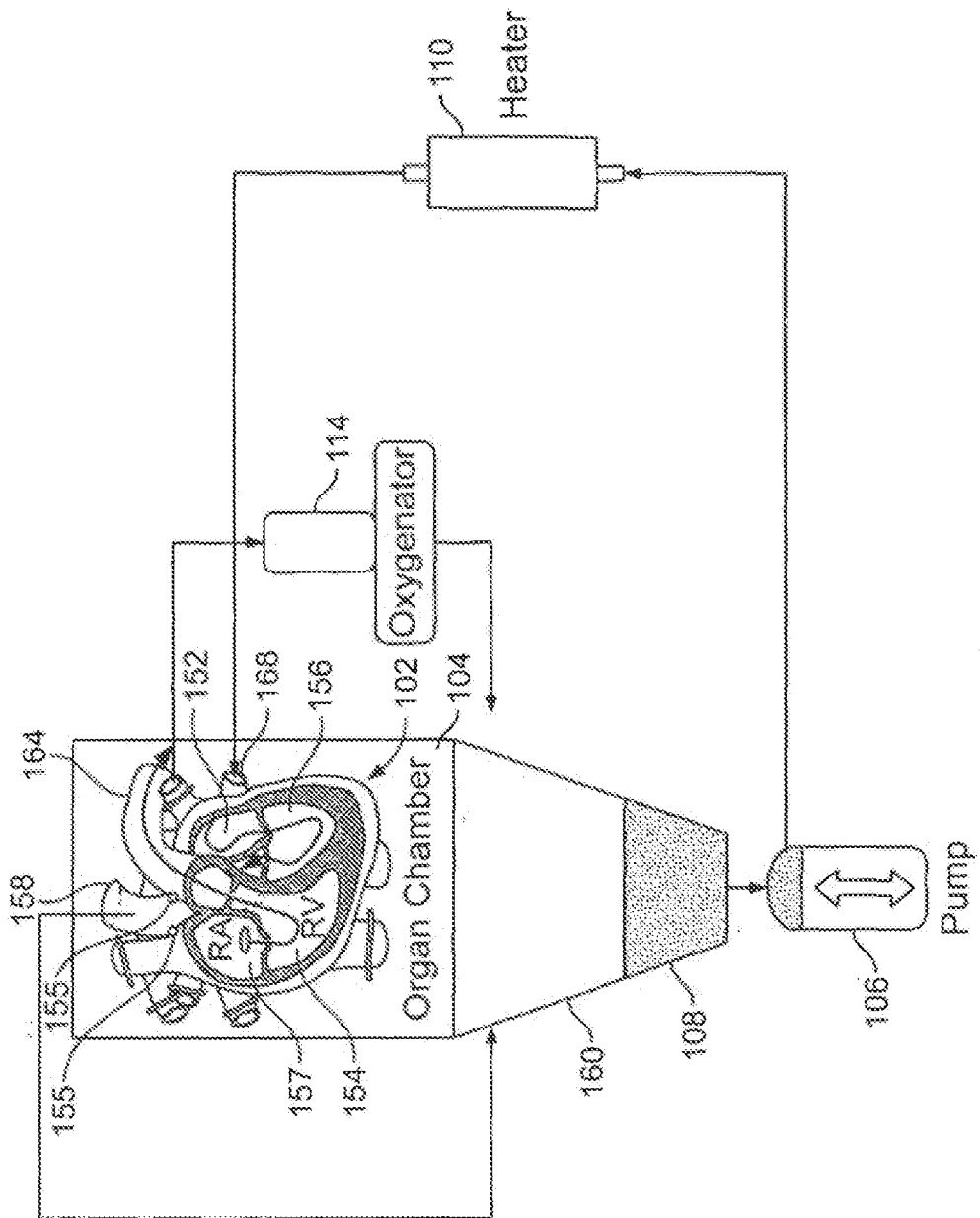

FIG. 3

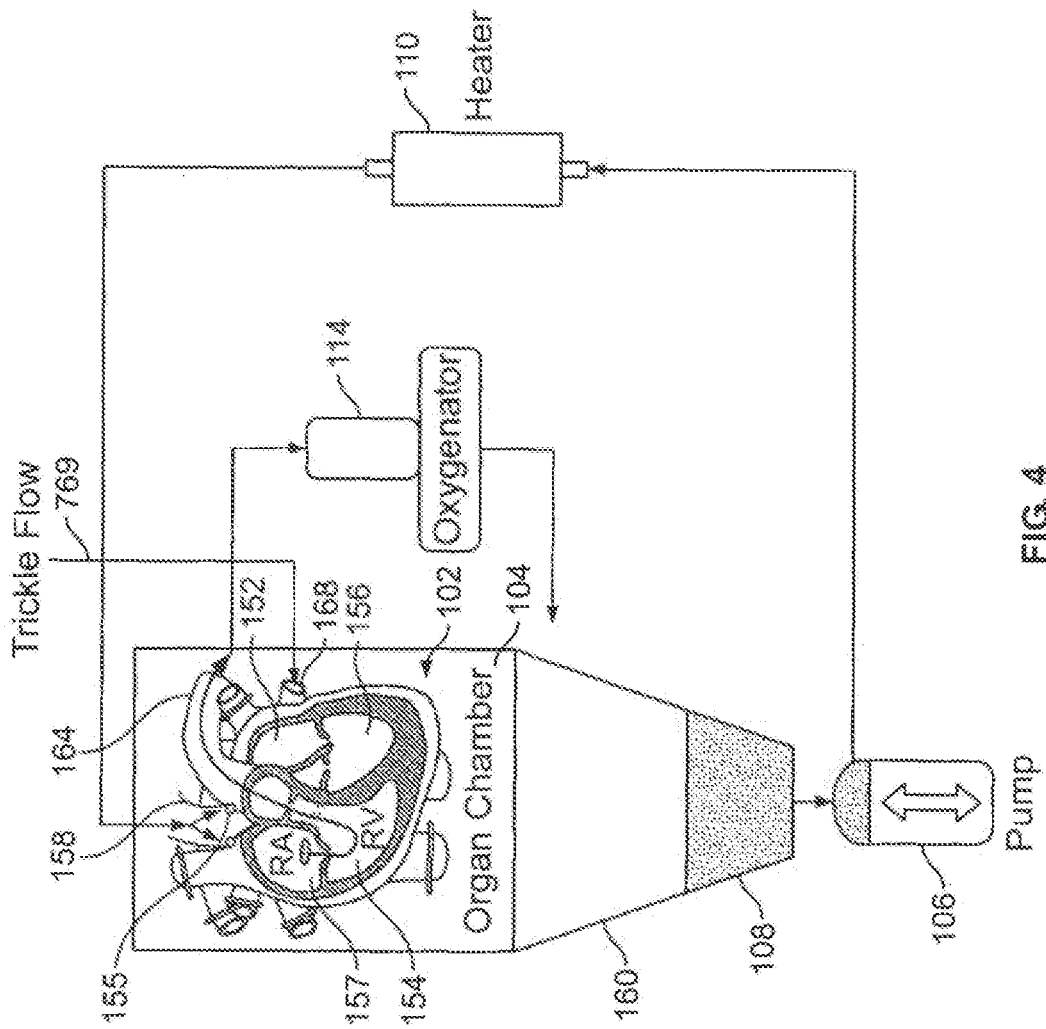

FIG. 4

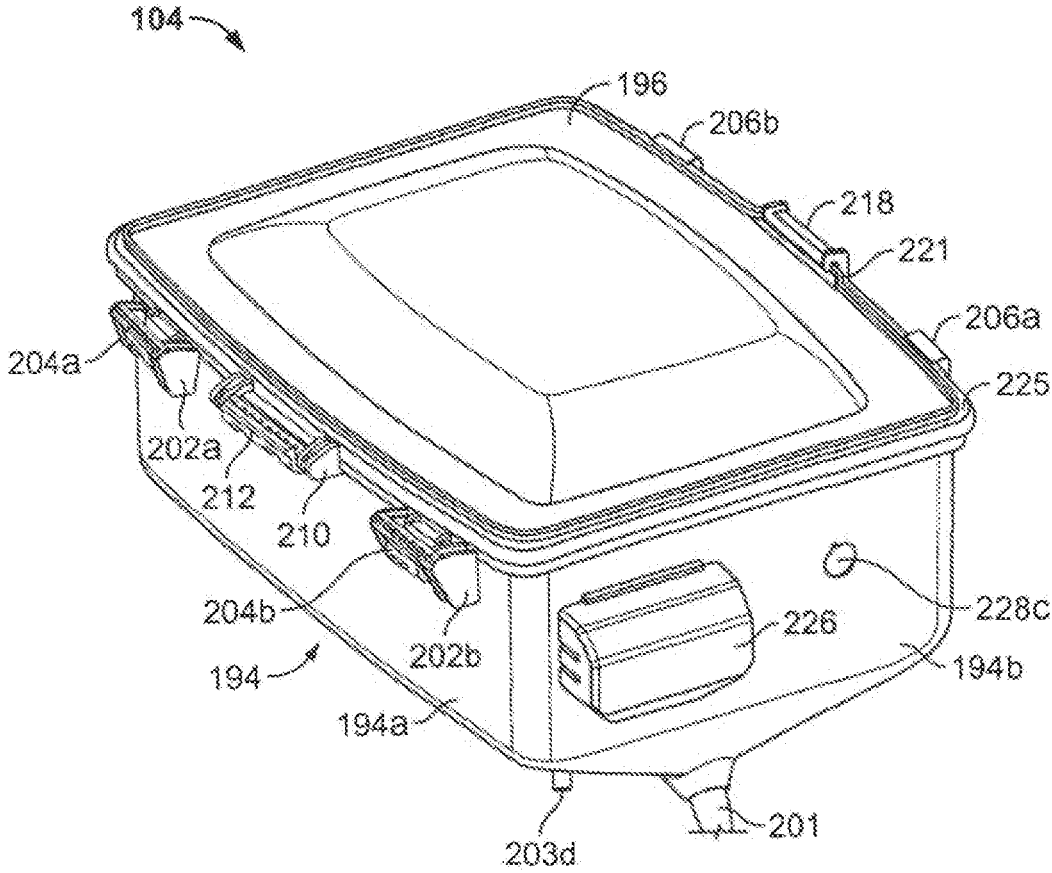

FIG. 5A

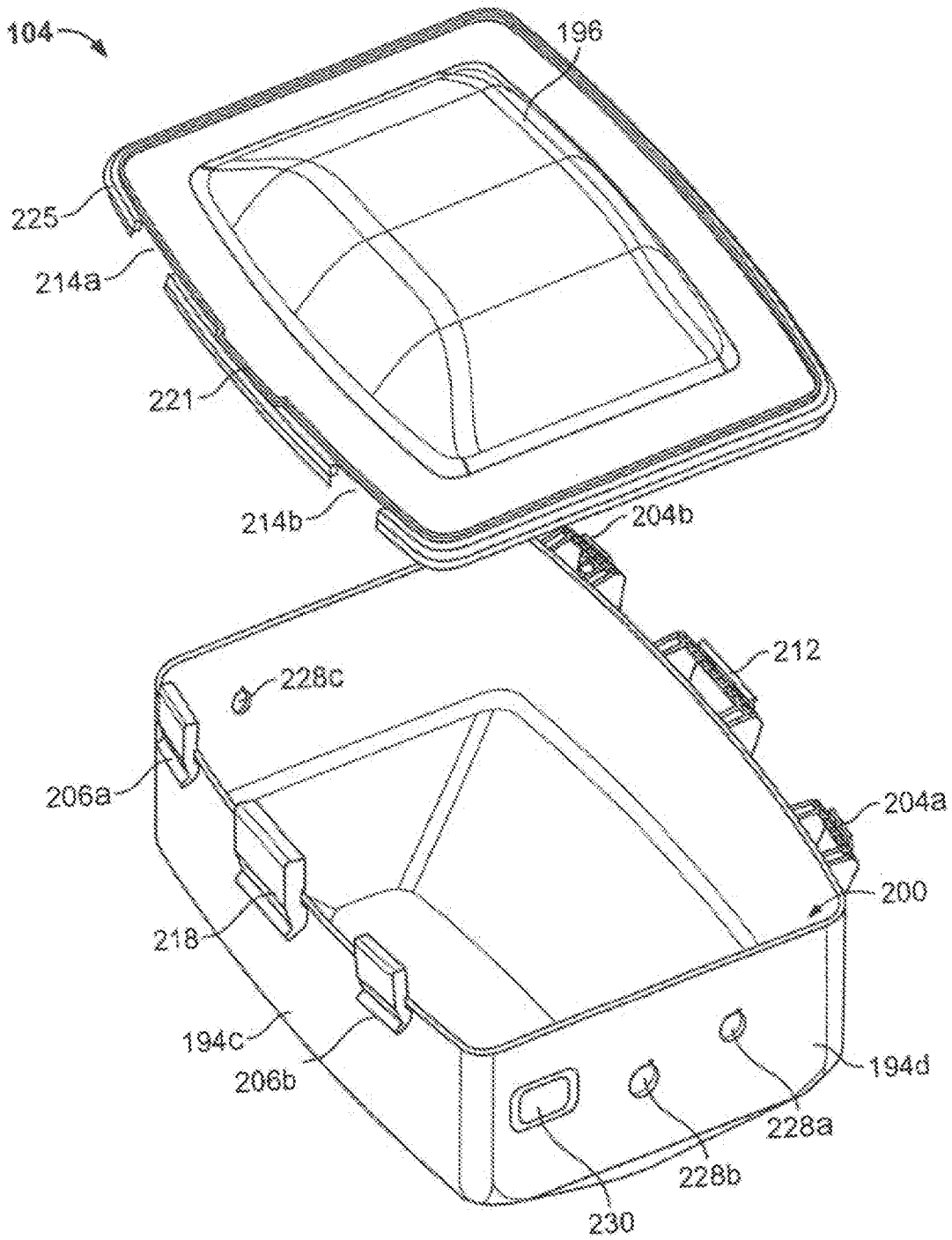

FIG. 5B

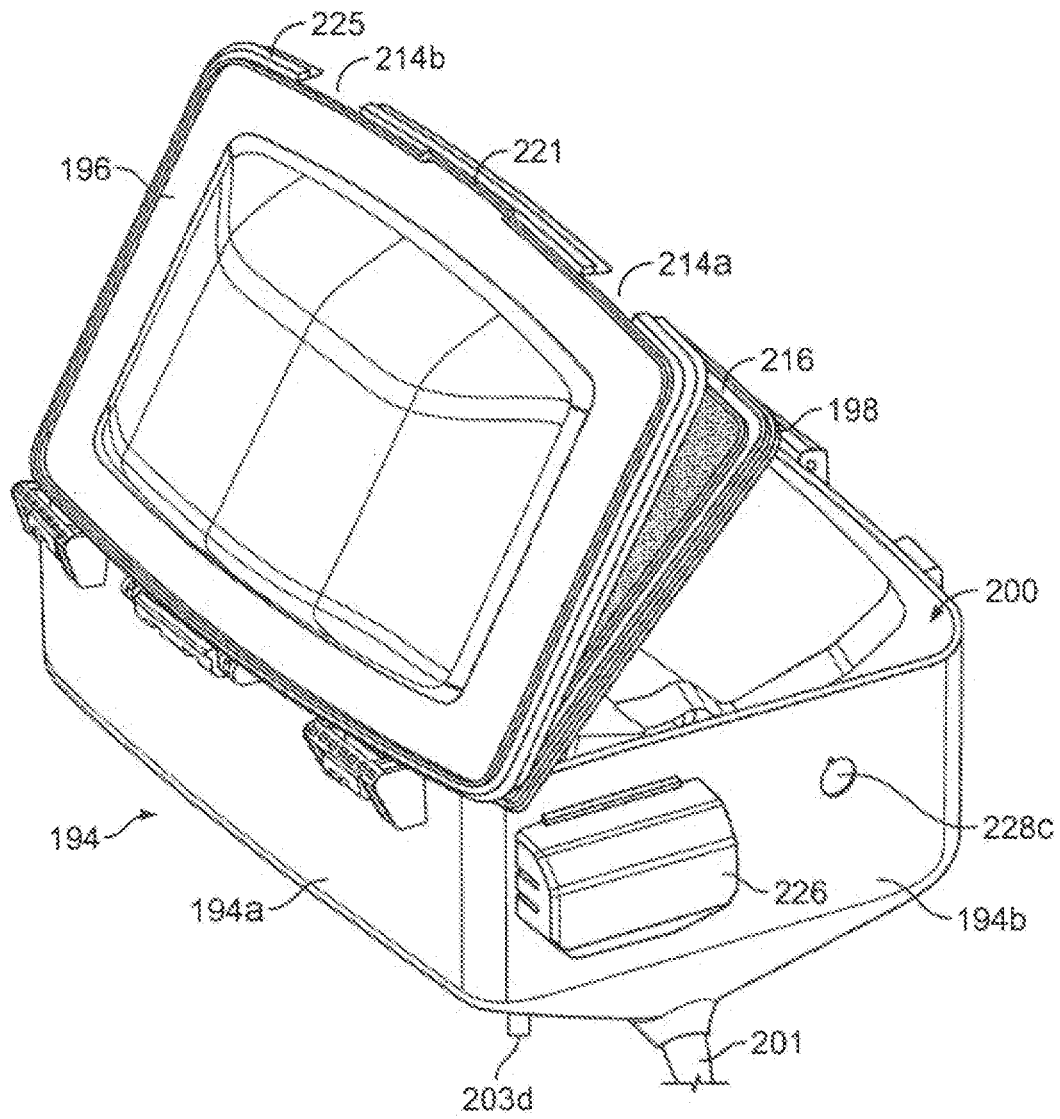

FIG. 5C

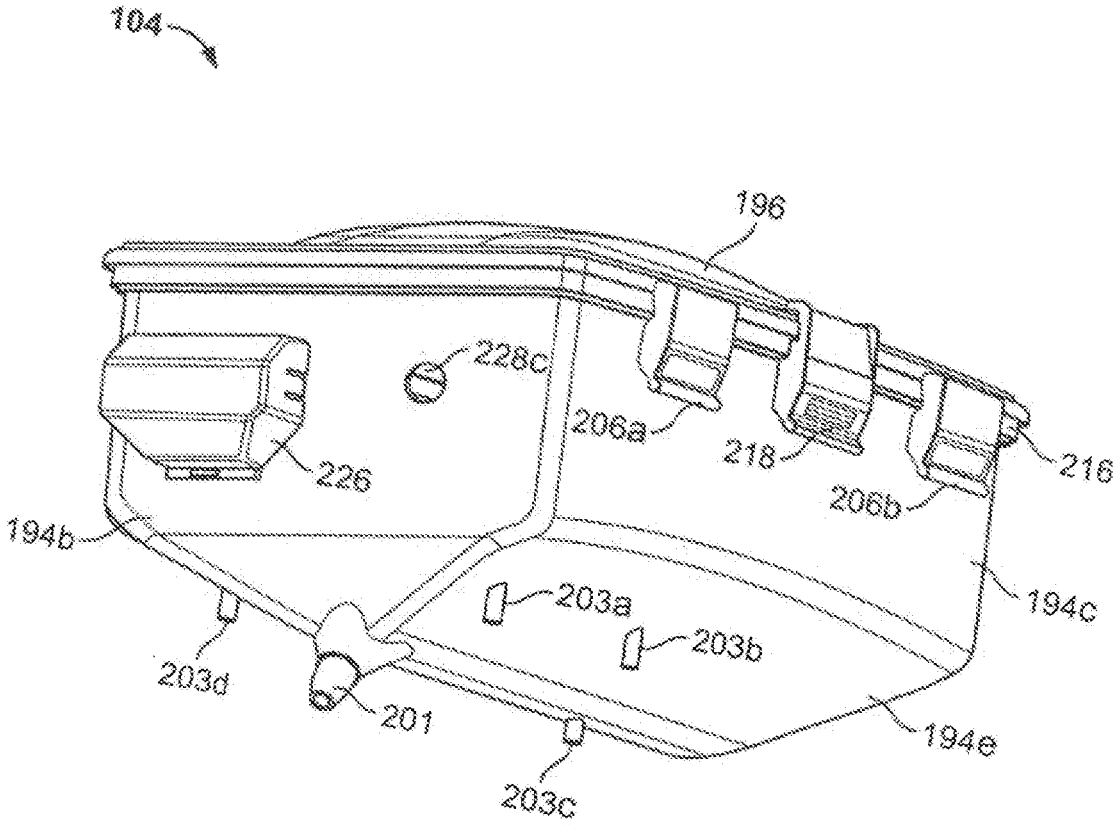

FIG. 5D

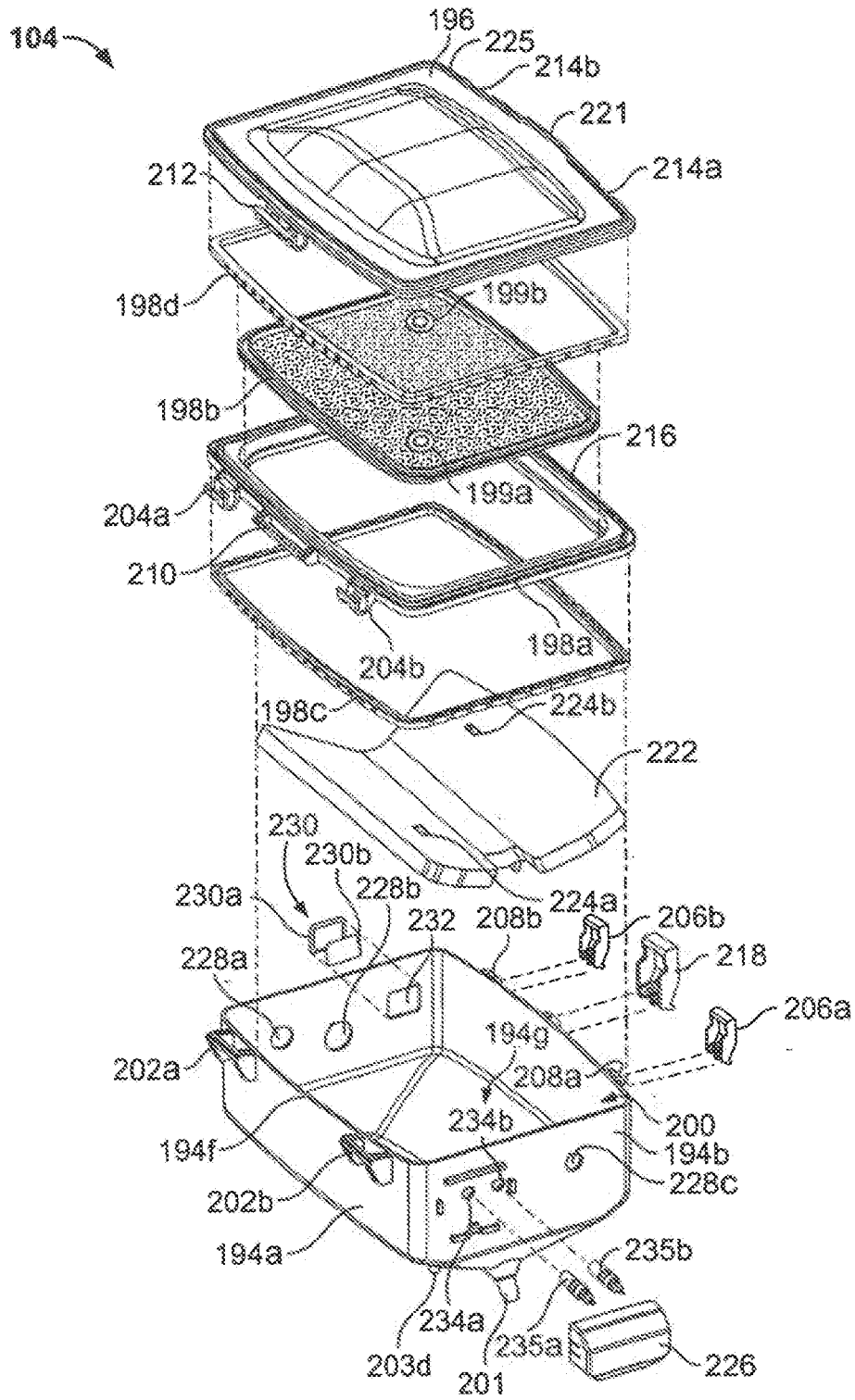

FIG. 5E

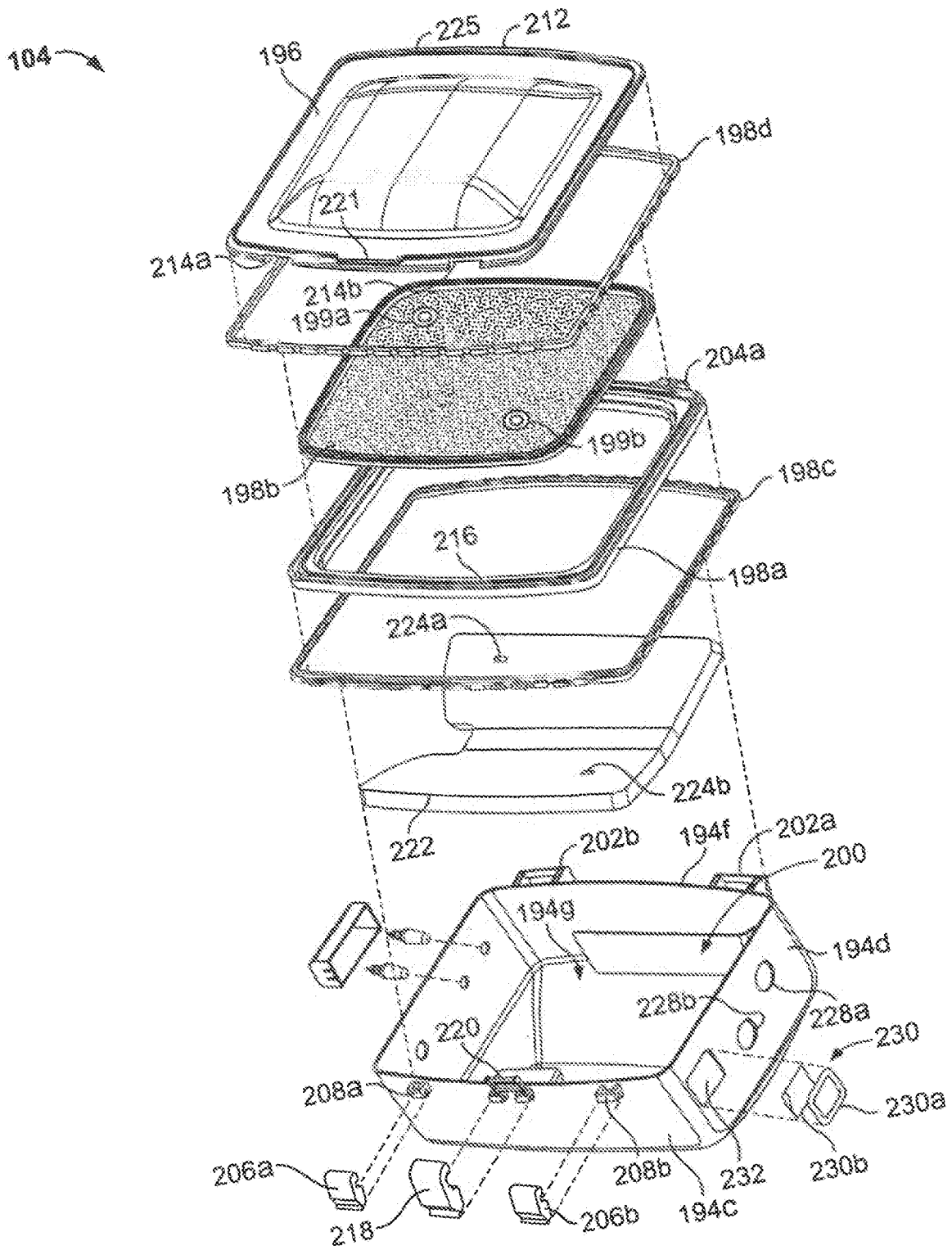

FIG. 5F

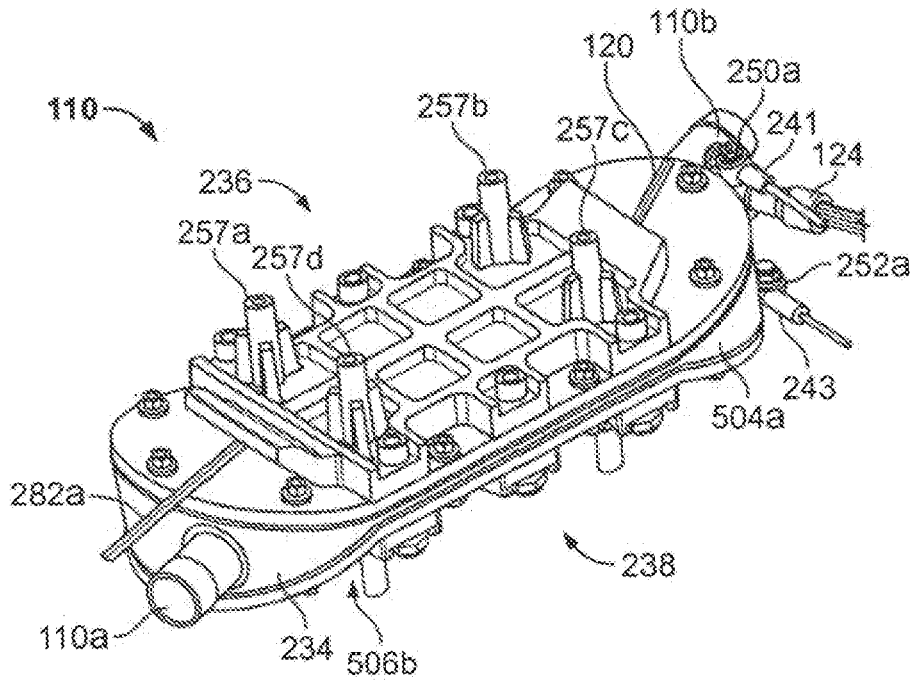

FIG. 6A

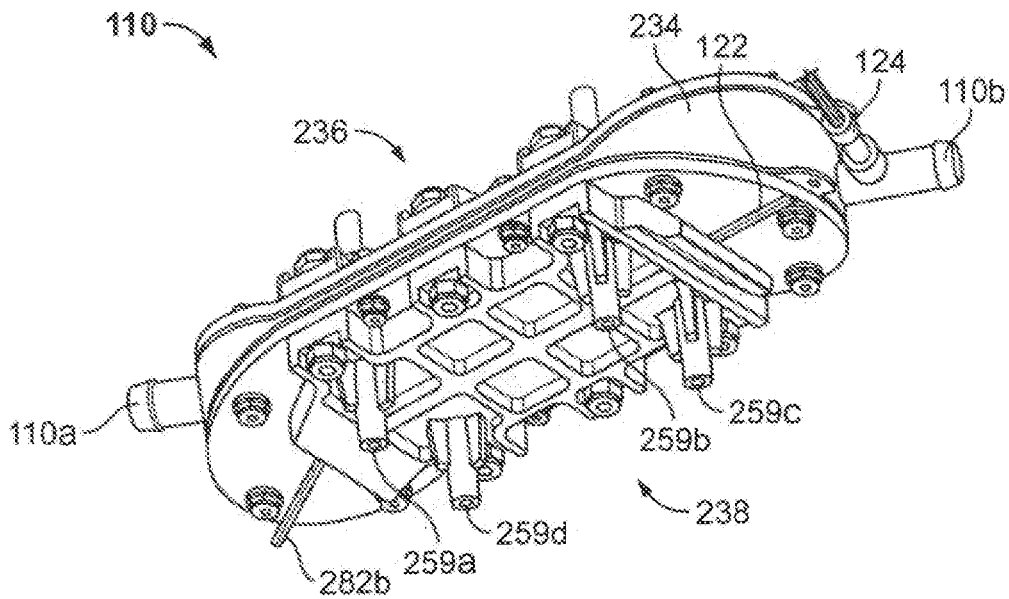

FIG. 6B

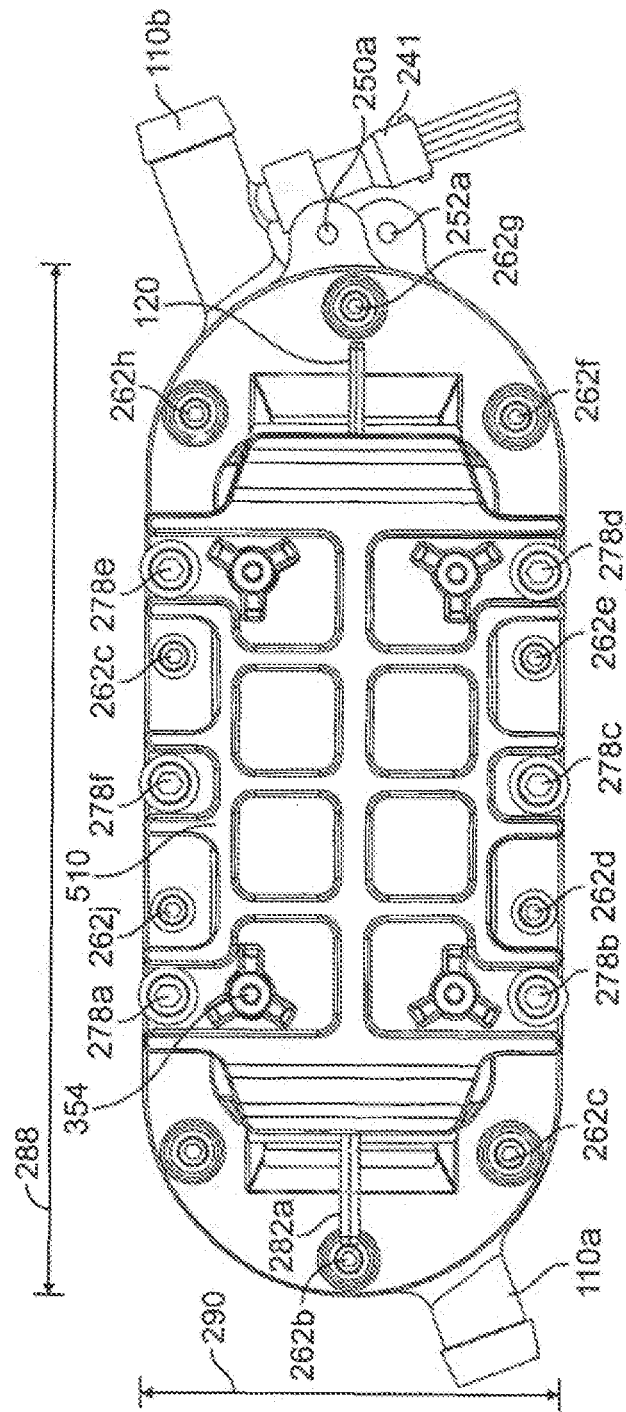

FIG. 6C

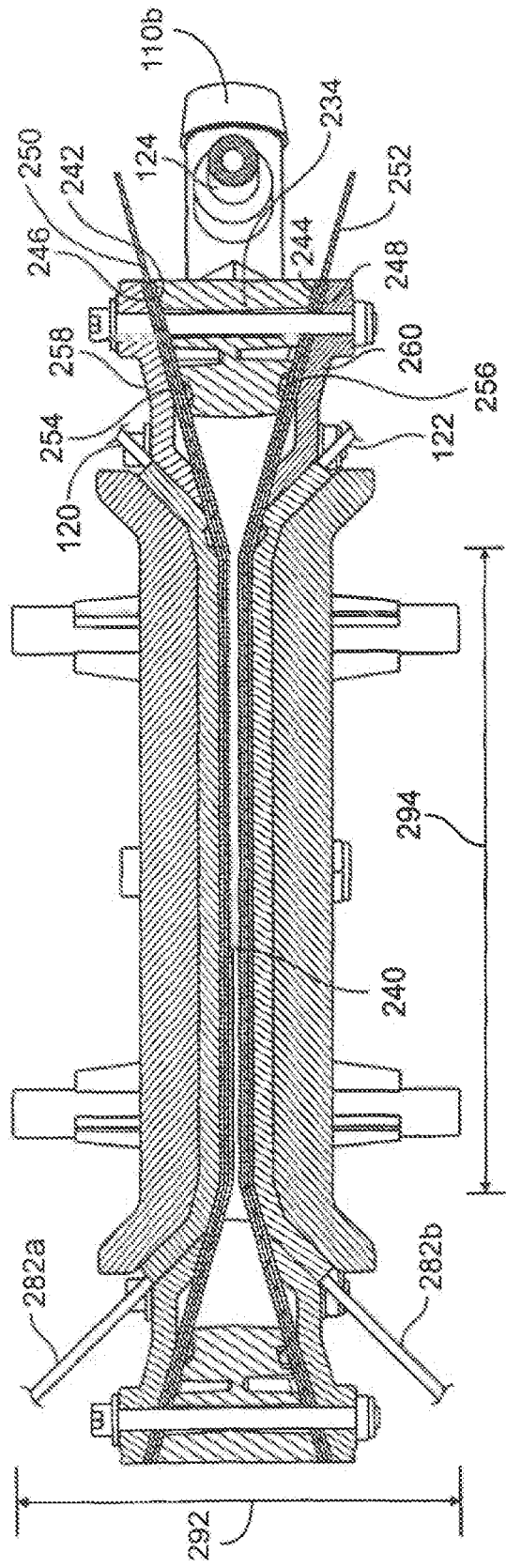

FIG. 6D

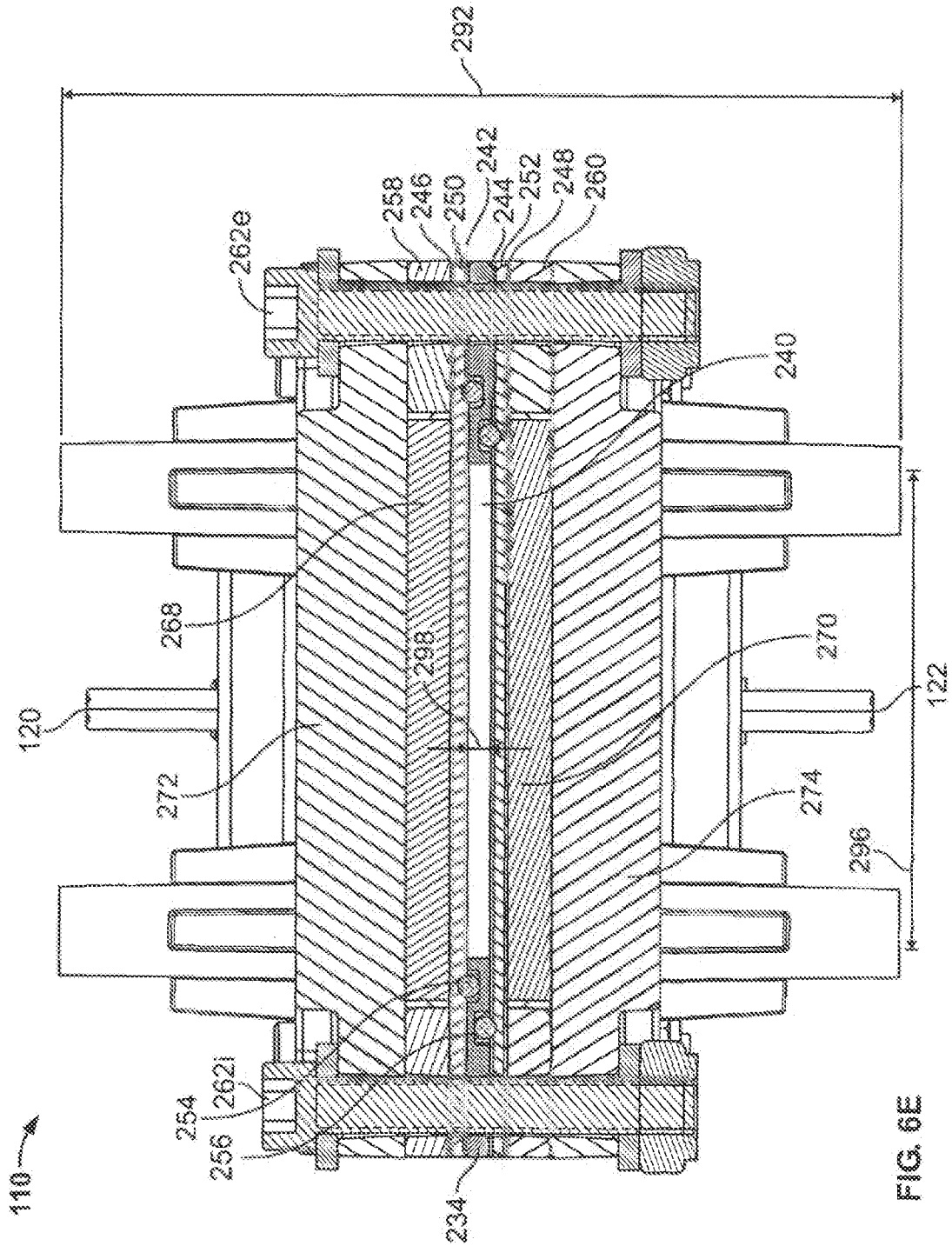

FIG. 6E

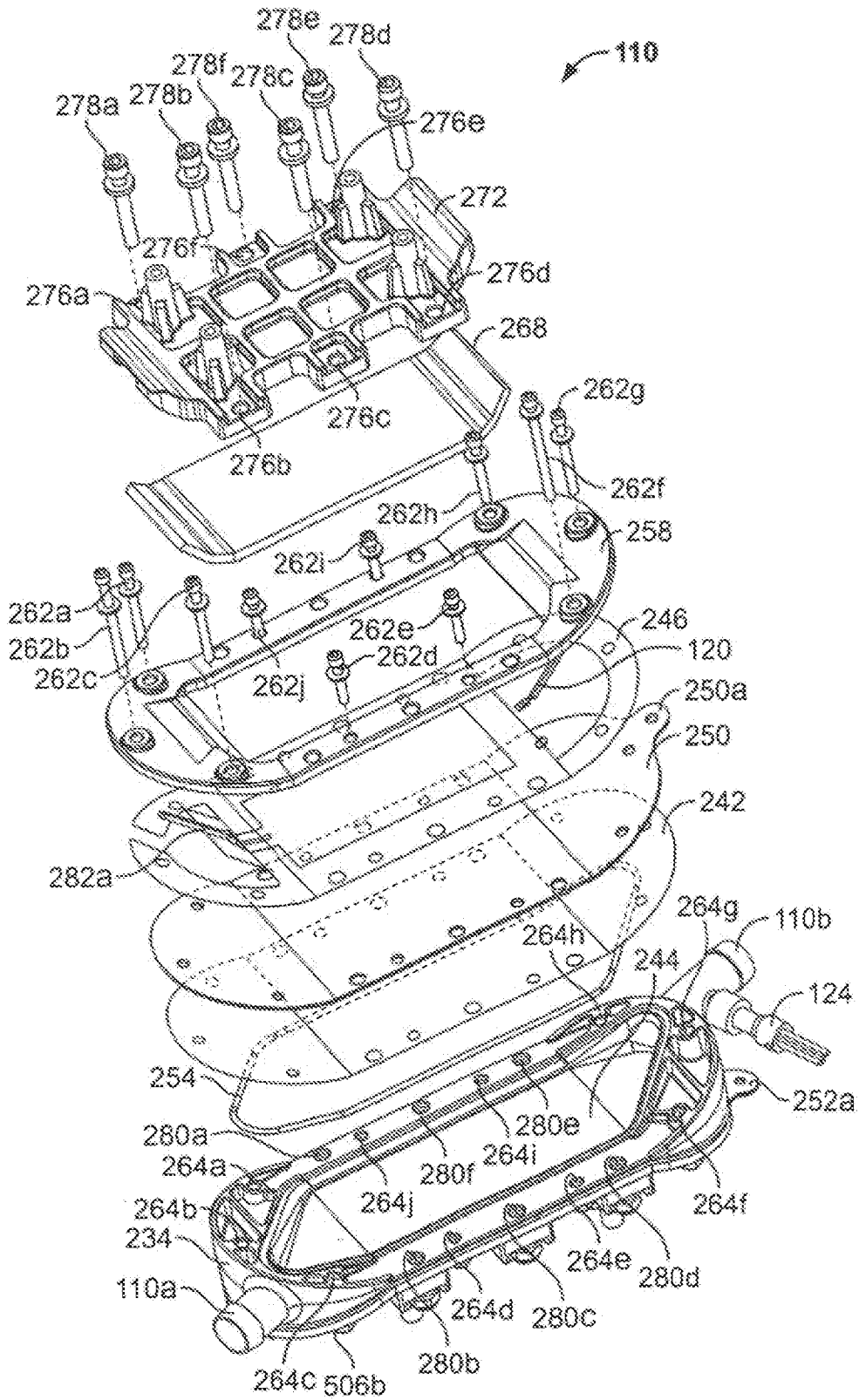

FIG. 6F

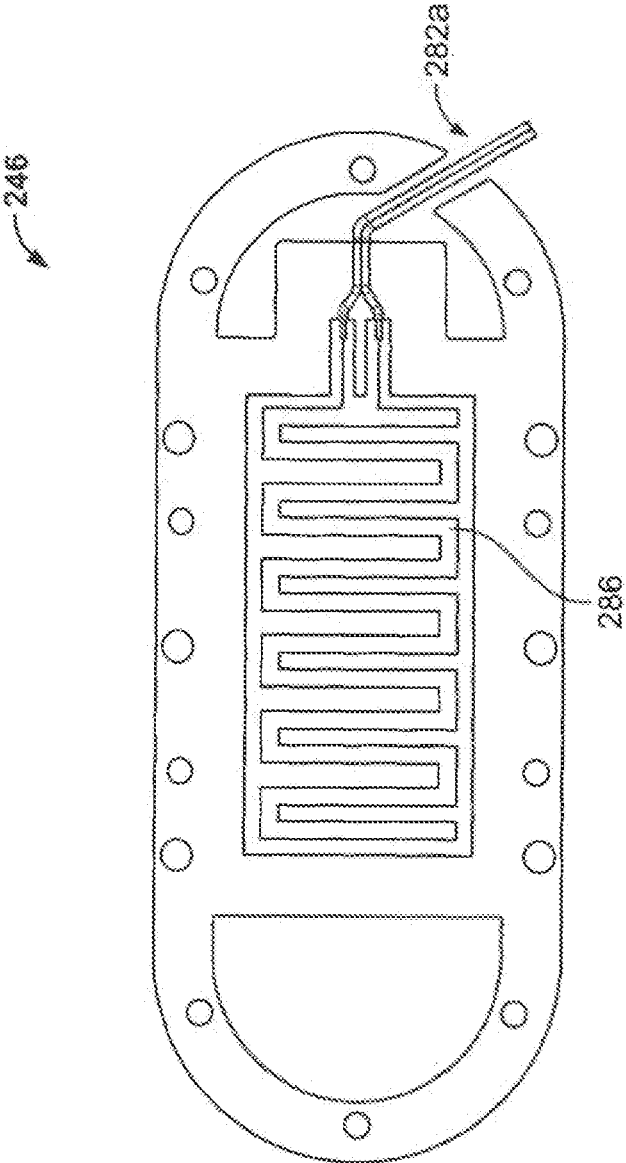

FIG. 7

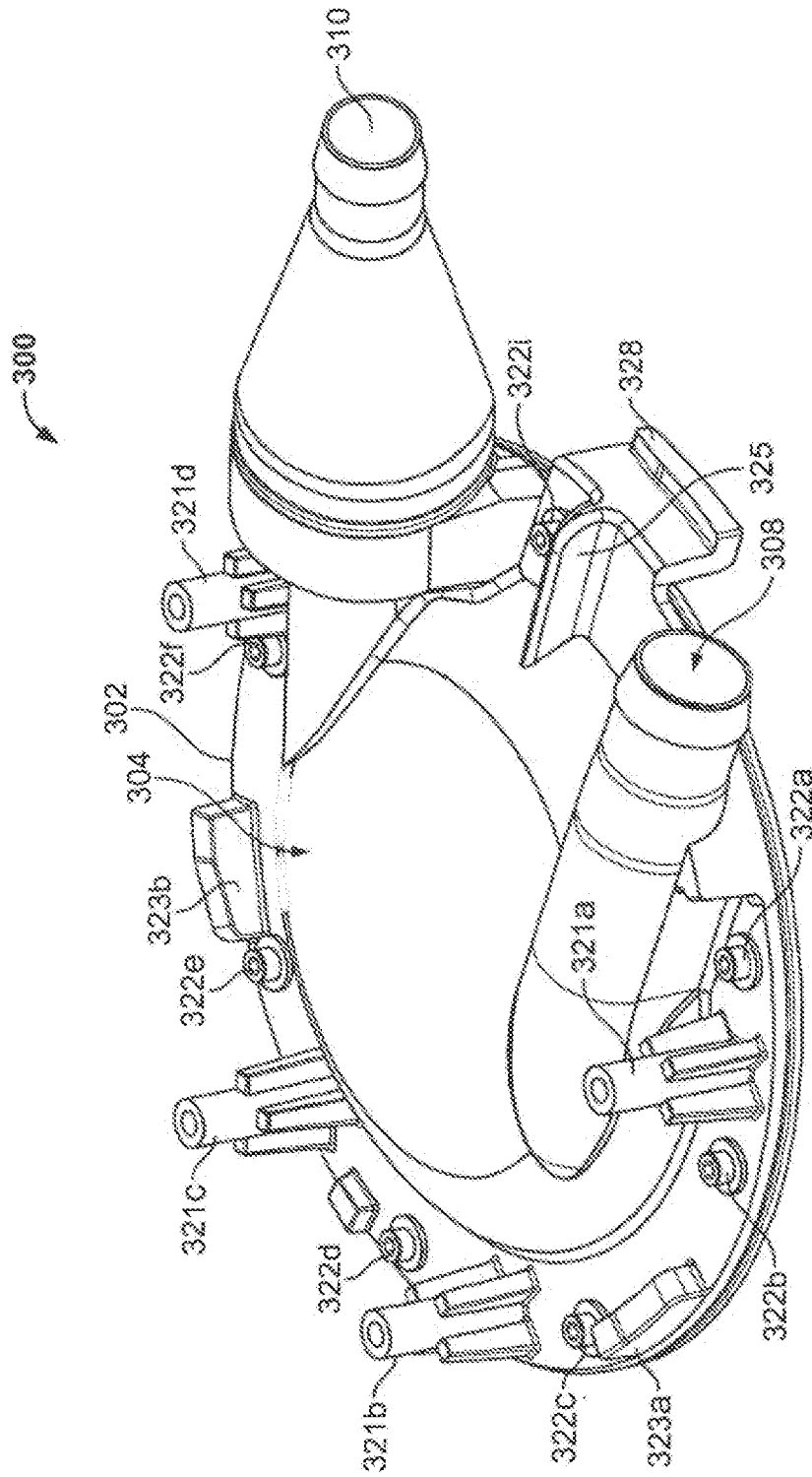

FIG. 8A

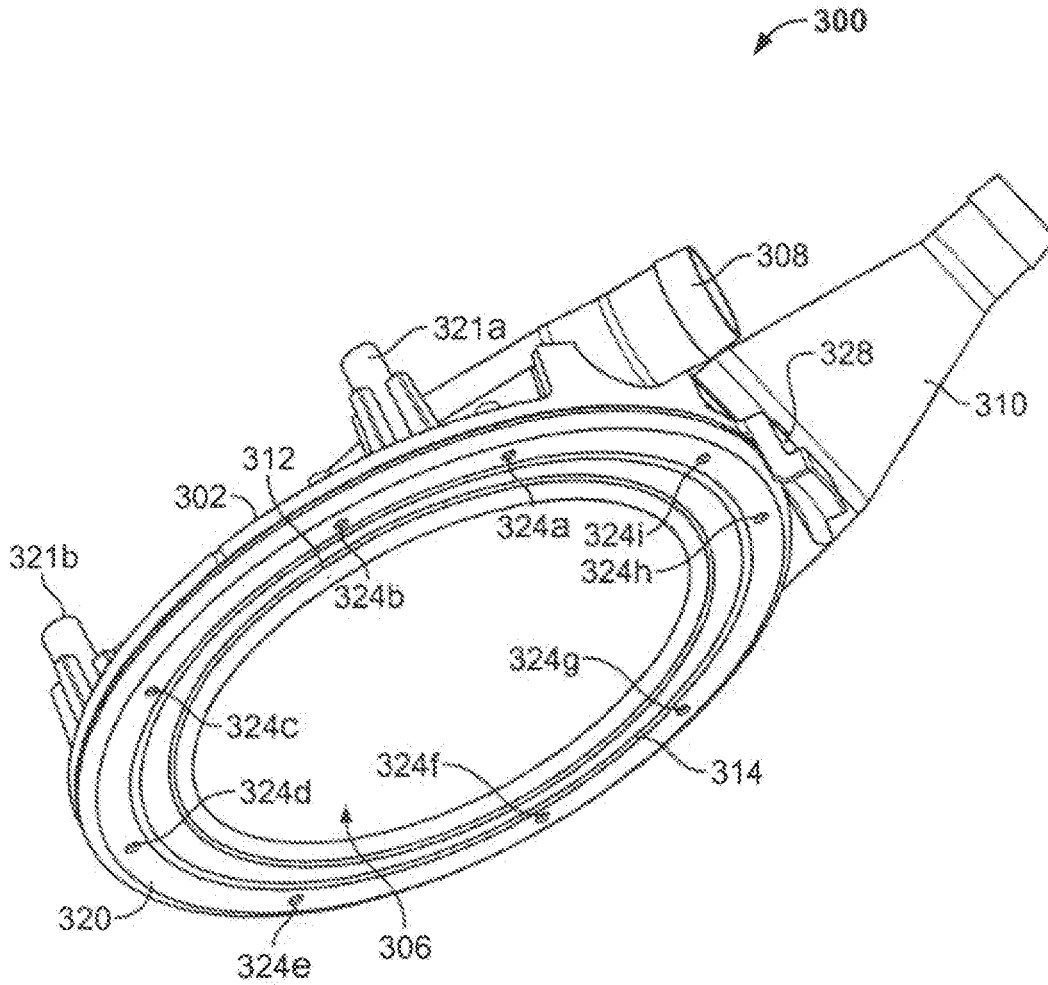

FIG. 8B

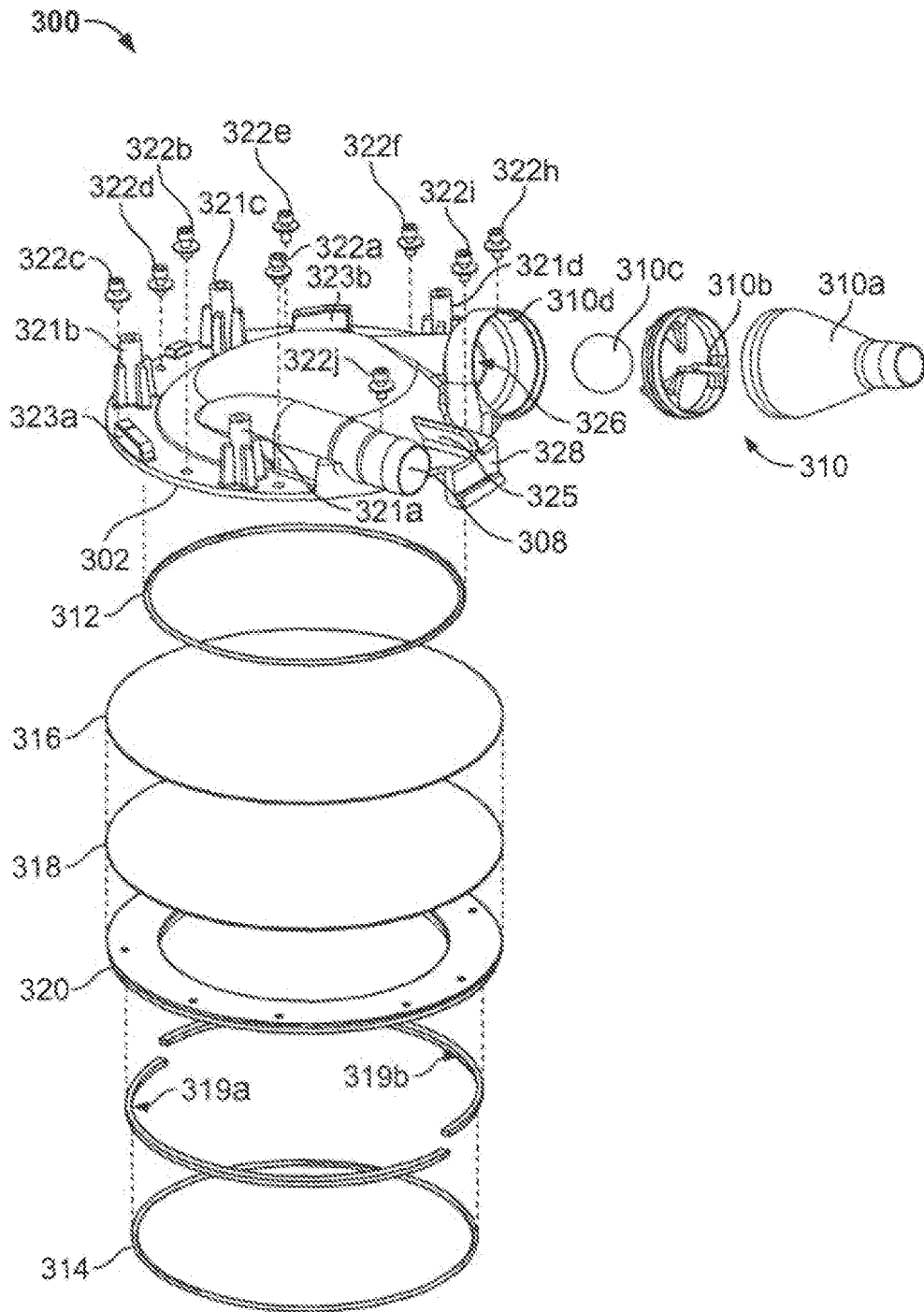

FIG. 8C

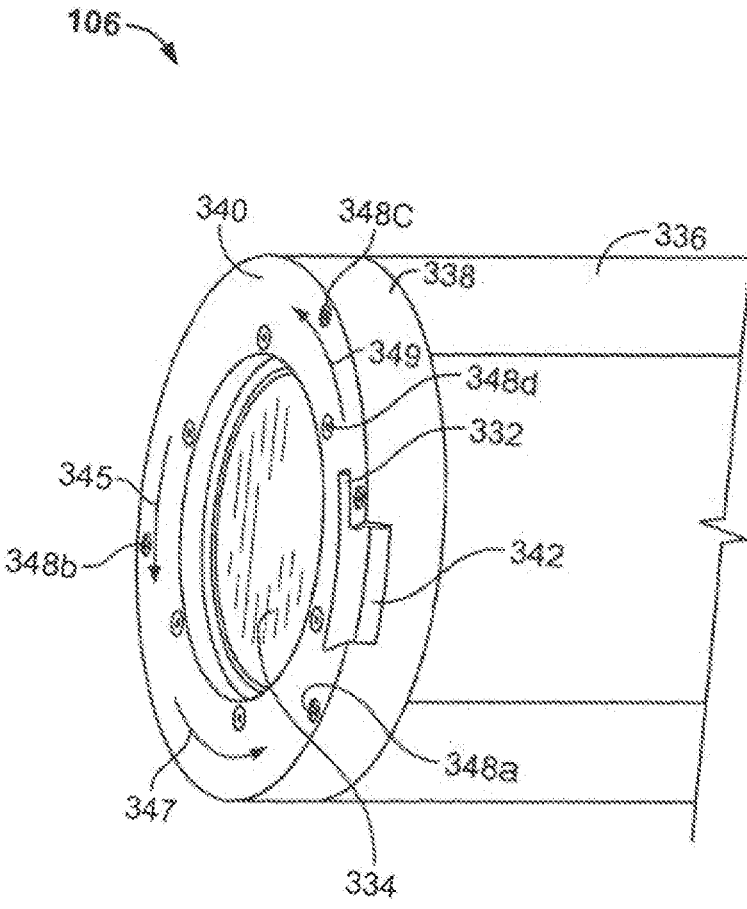

FIG. 9

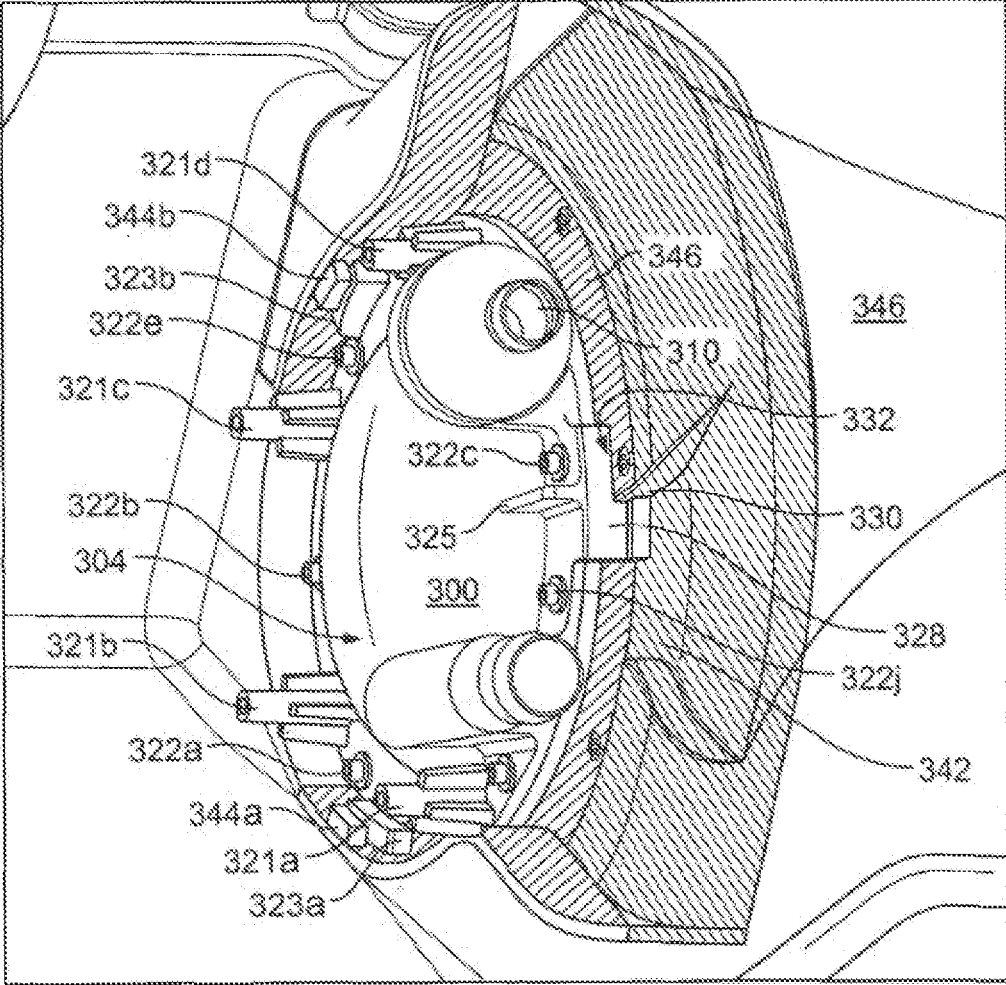

FIG. 10

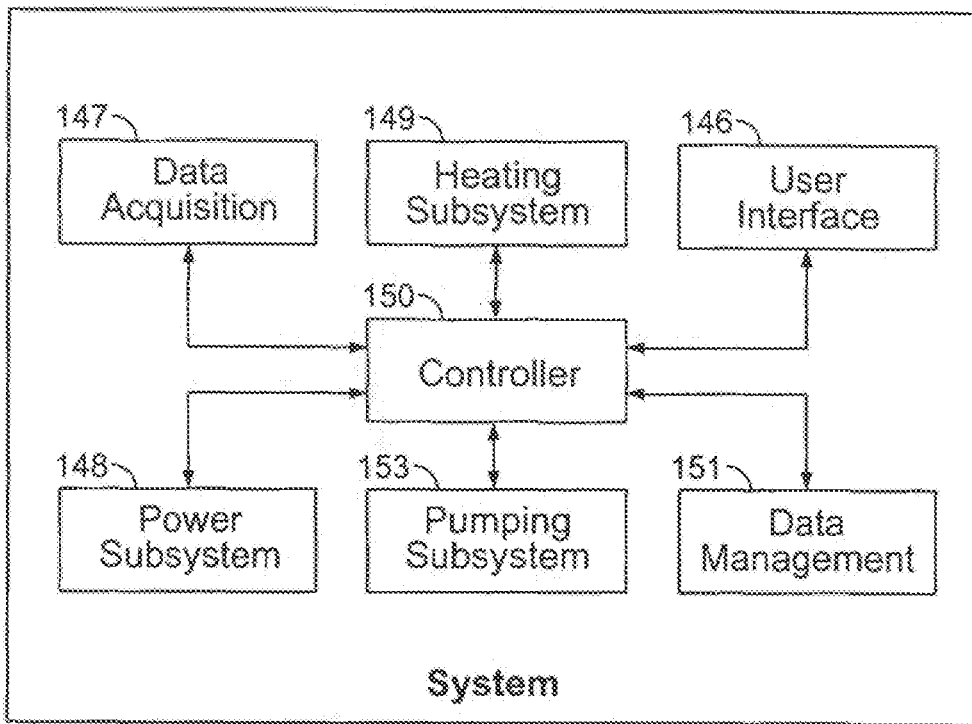

FIG. 11

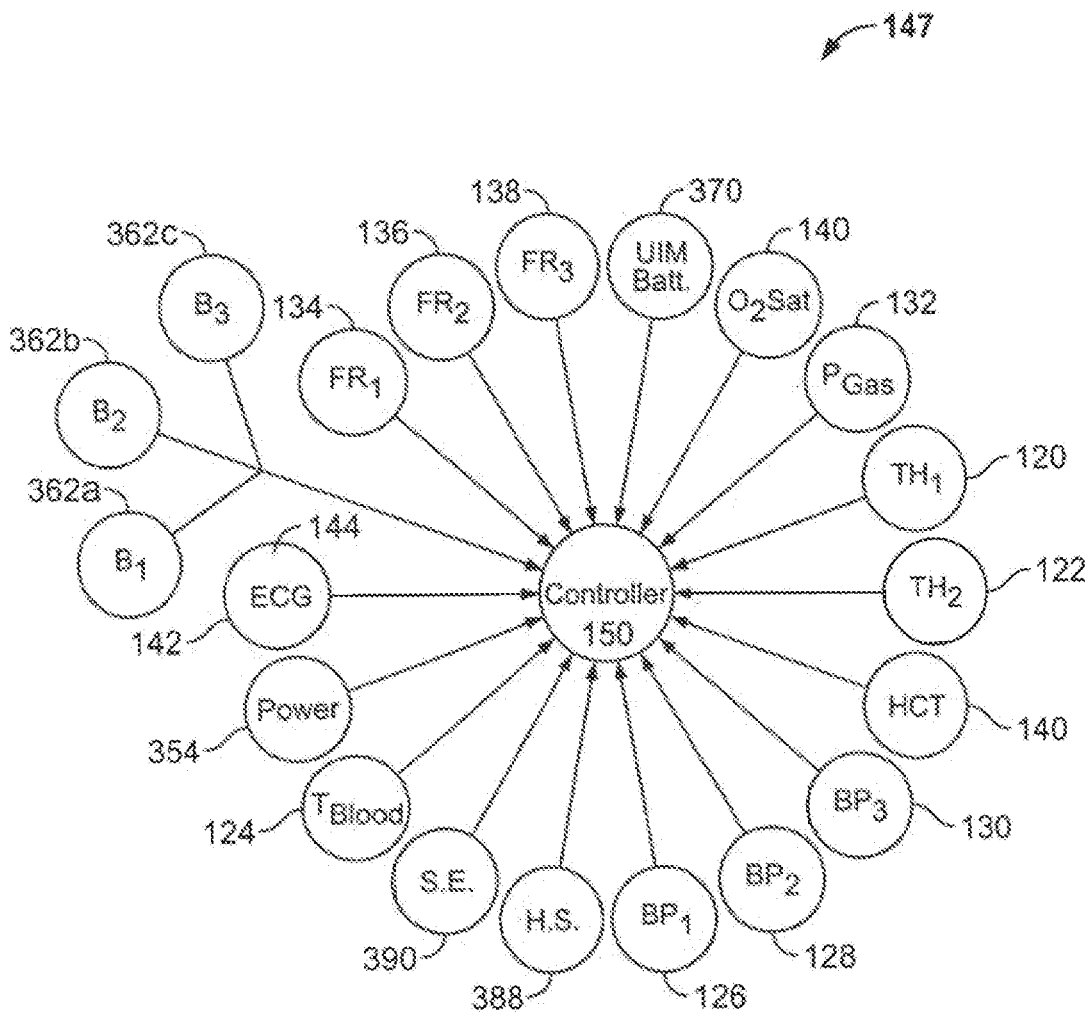

FIG. 12

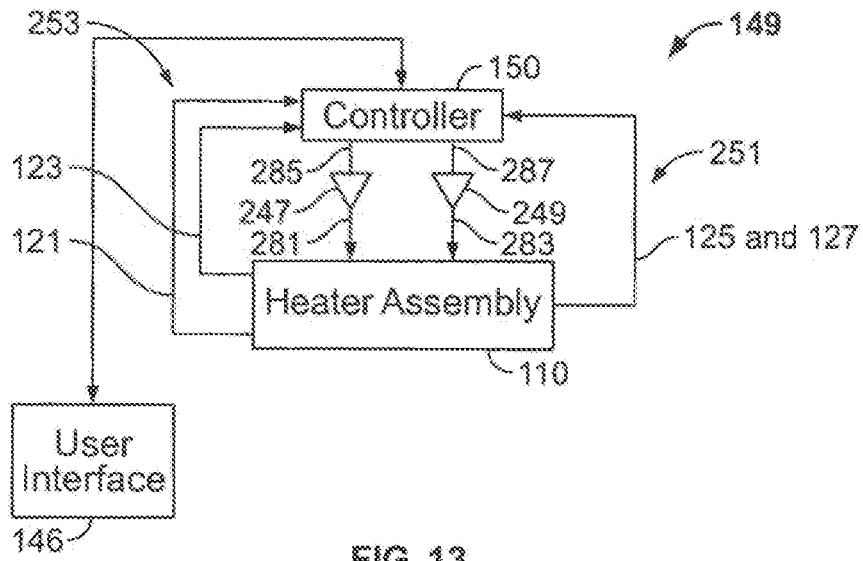

FIG. 13

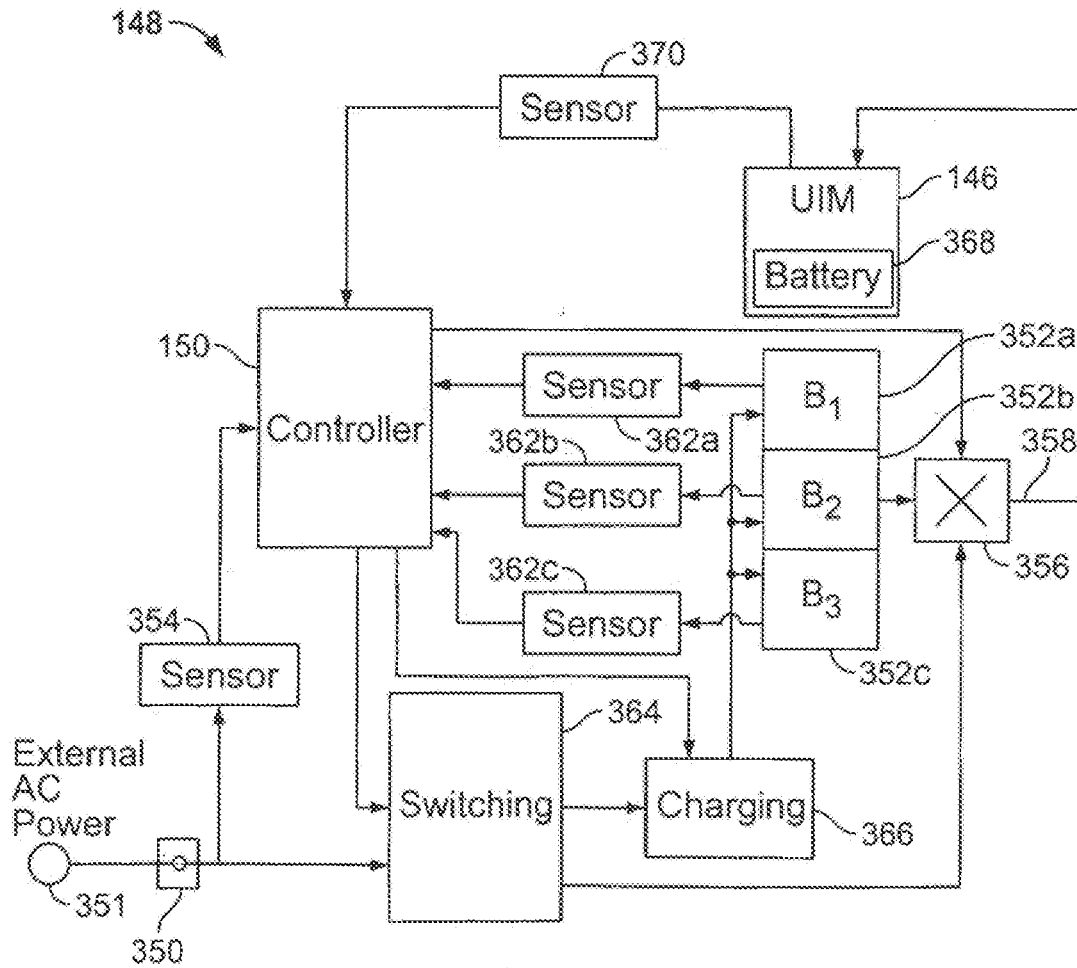

FIG. 14

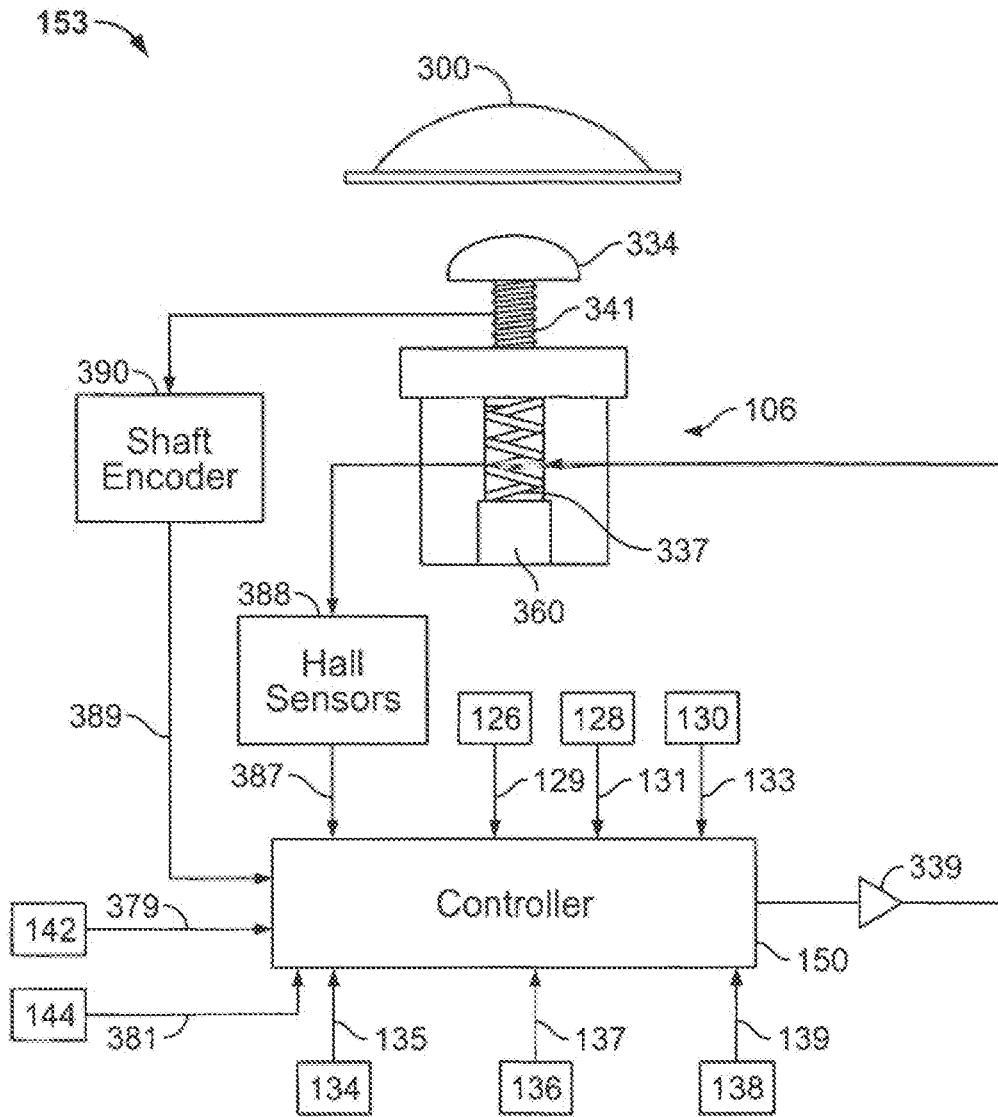

FIG. 15

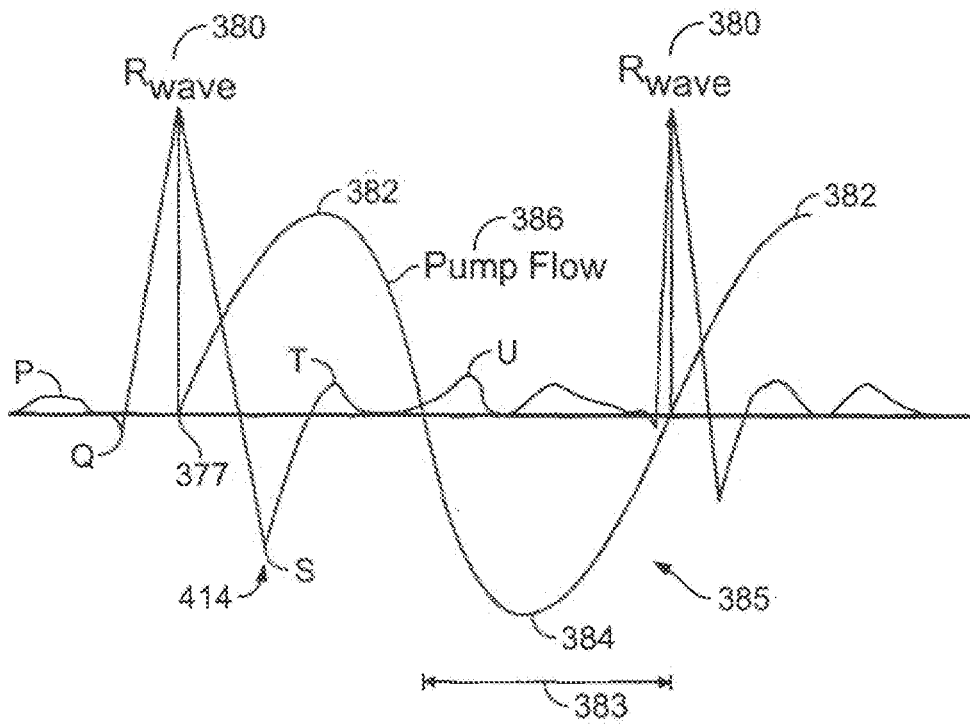

FIG. 16

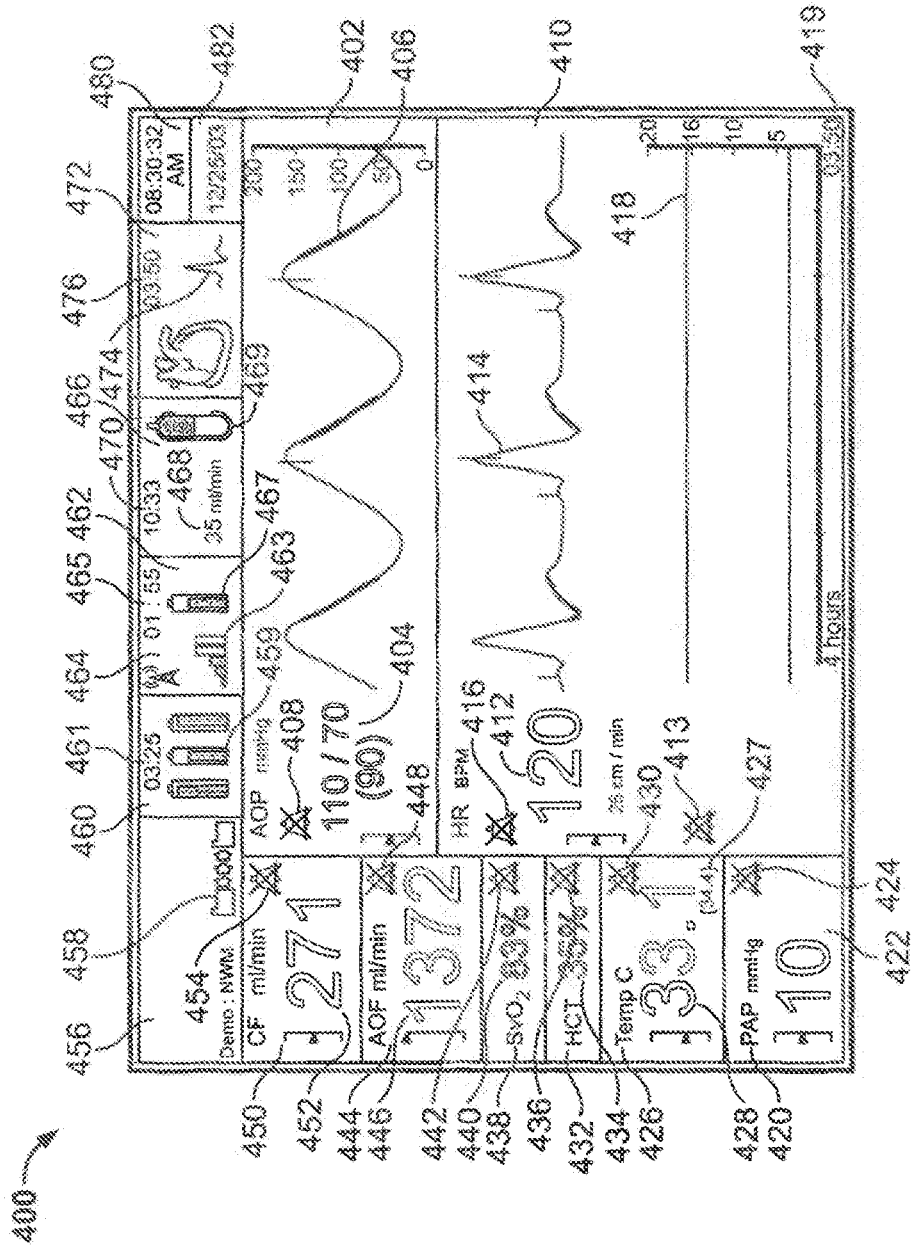

FIG. 17A

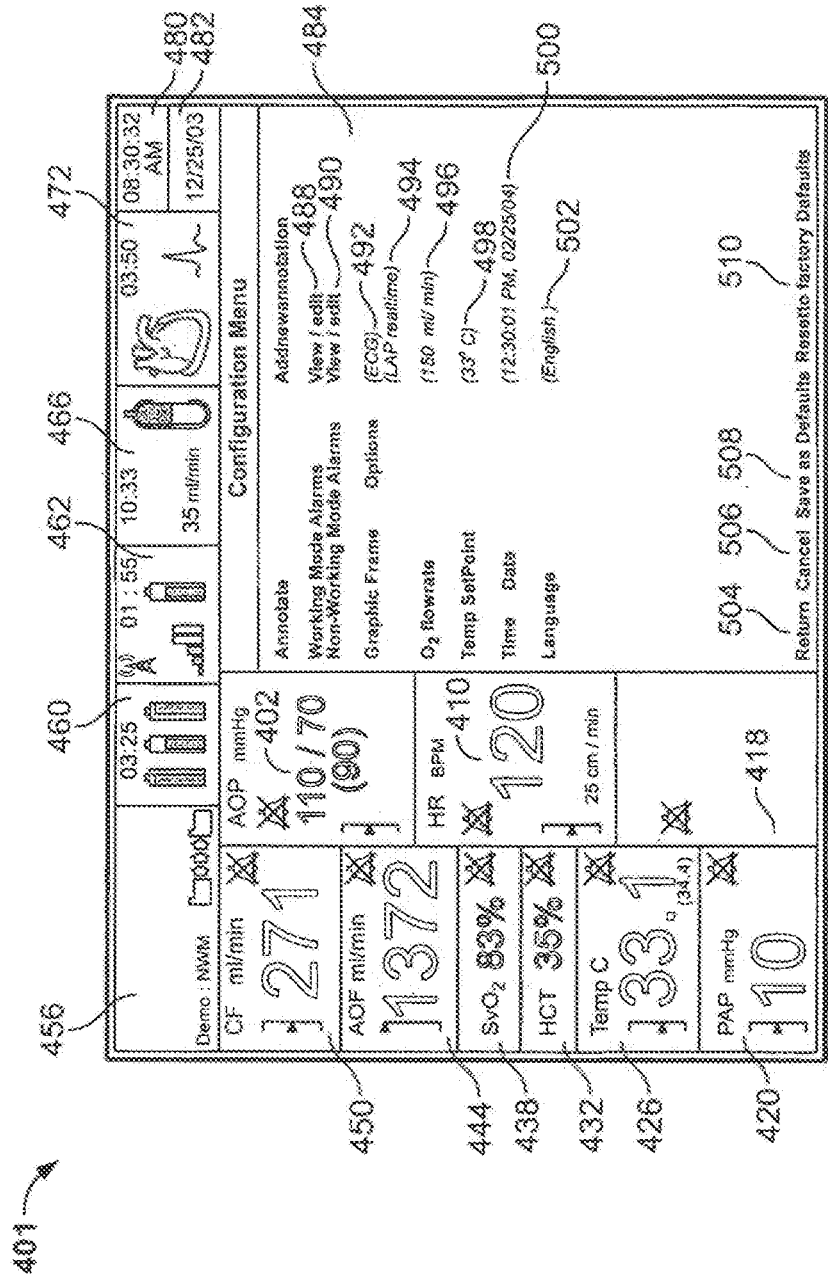

FIG. 17B

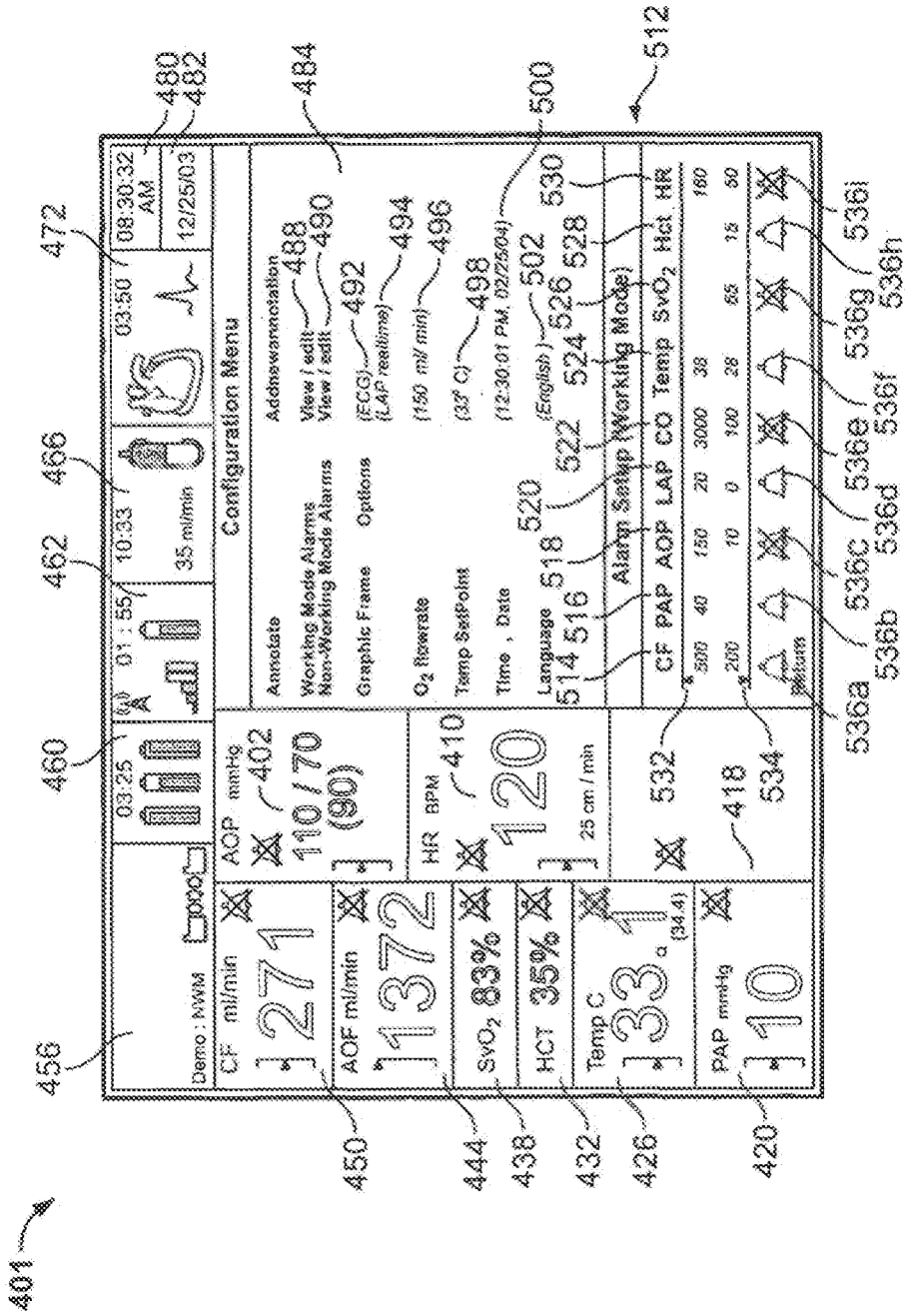

FIG. 17C

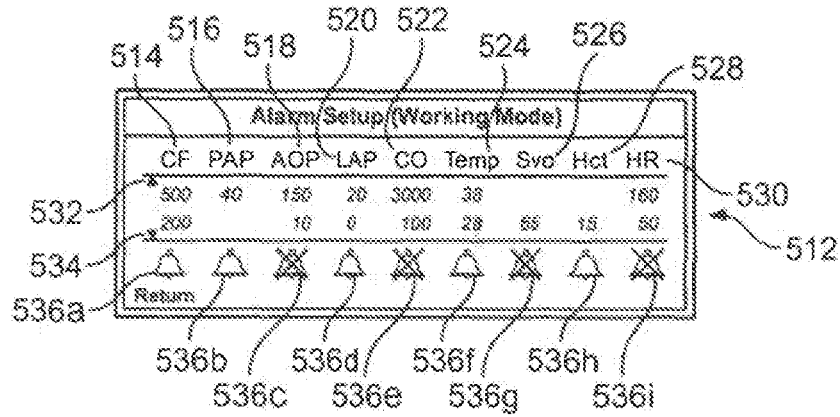

FIG. 17D

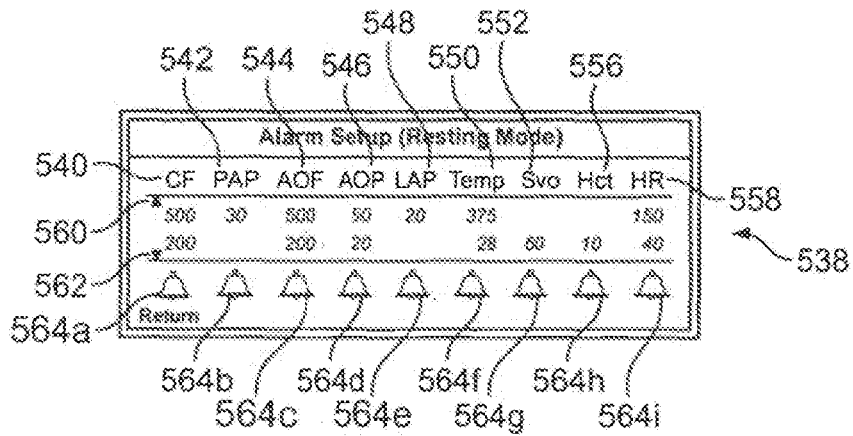

FIG. 17E

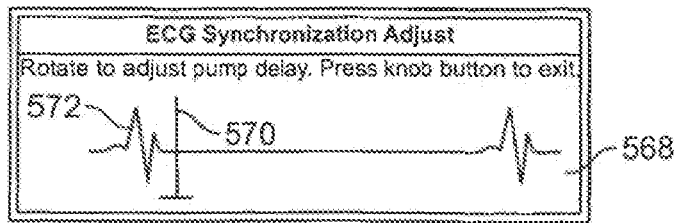

FIG. 17F

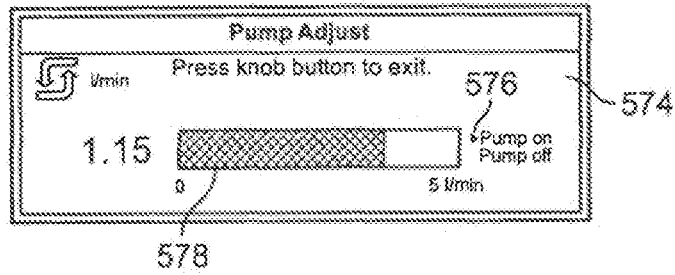

FIG. 17G

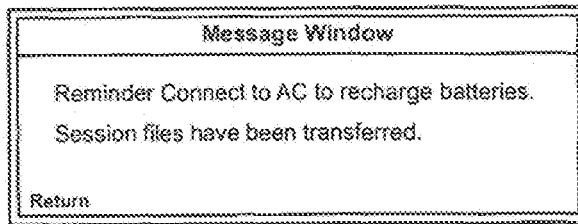

FIG. 17H

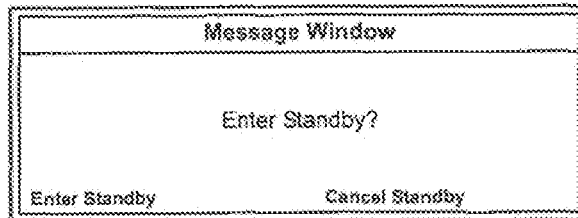

FIG. 17I

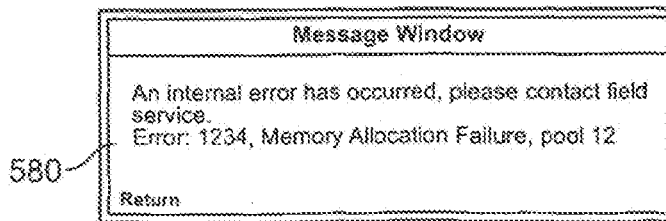

FIG. 17J

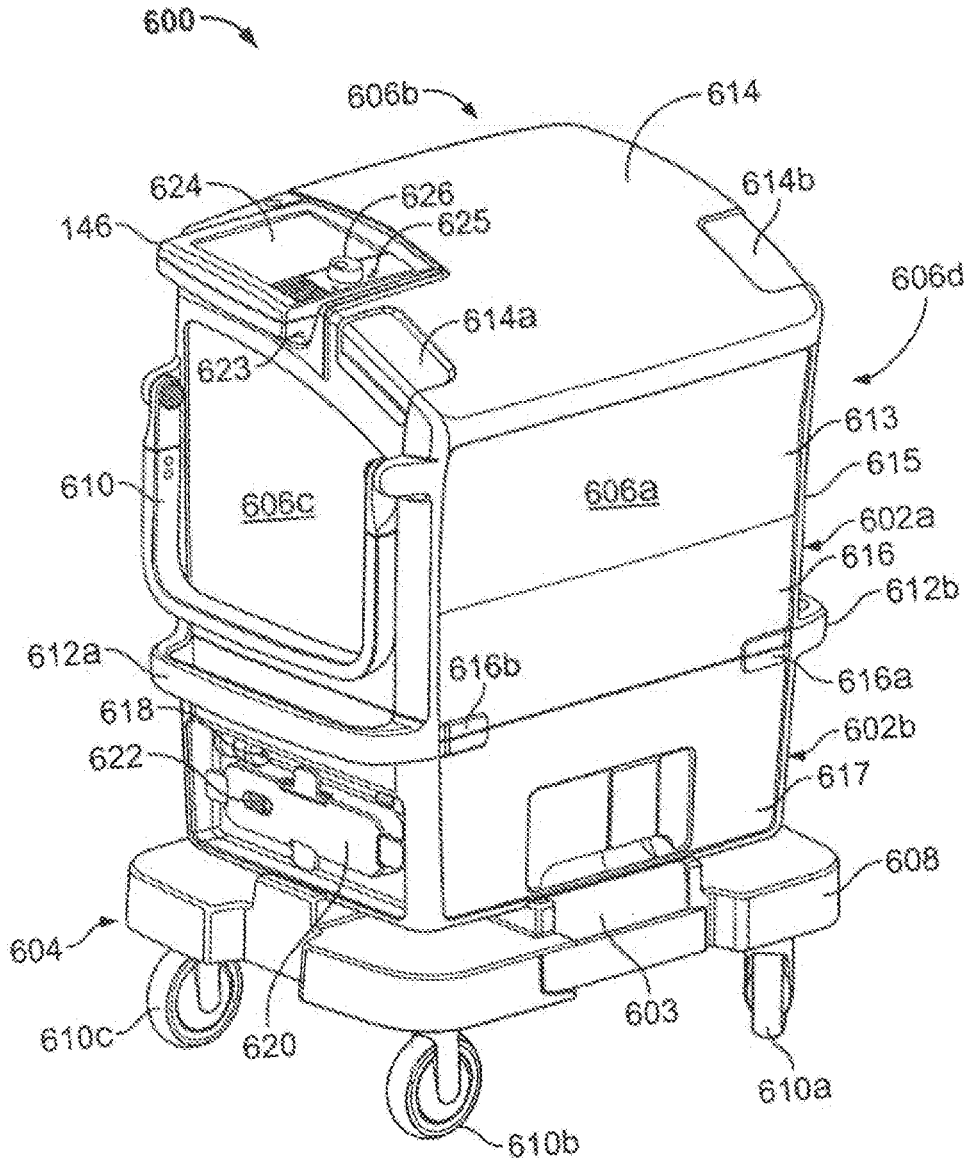

FIG. 18A

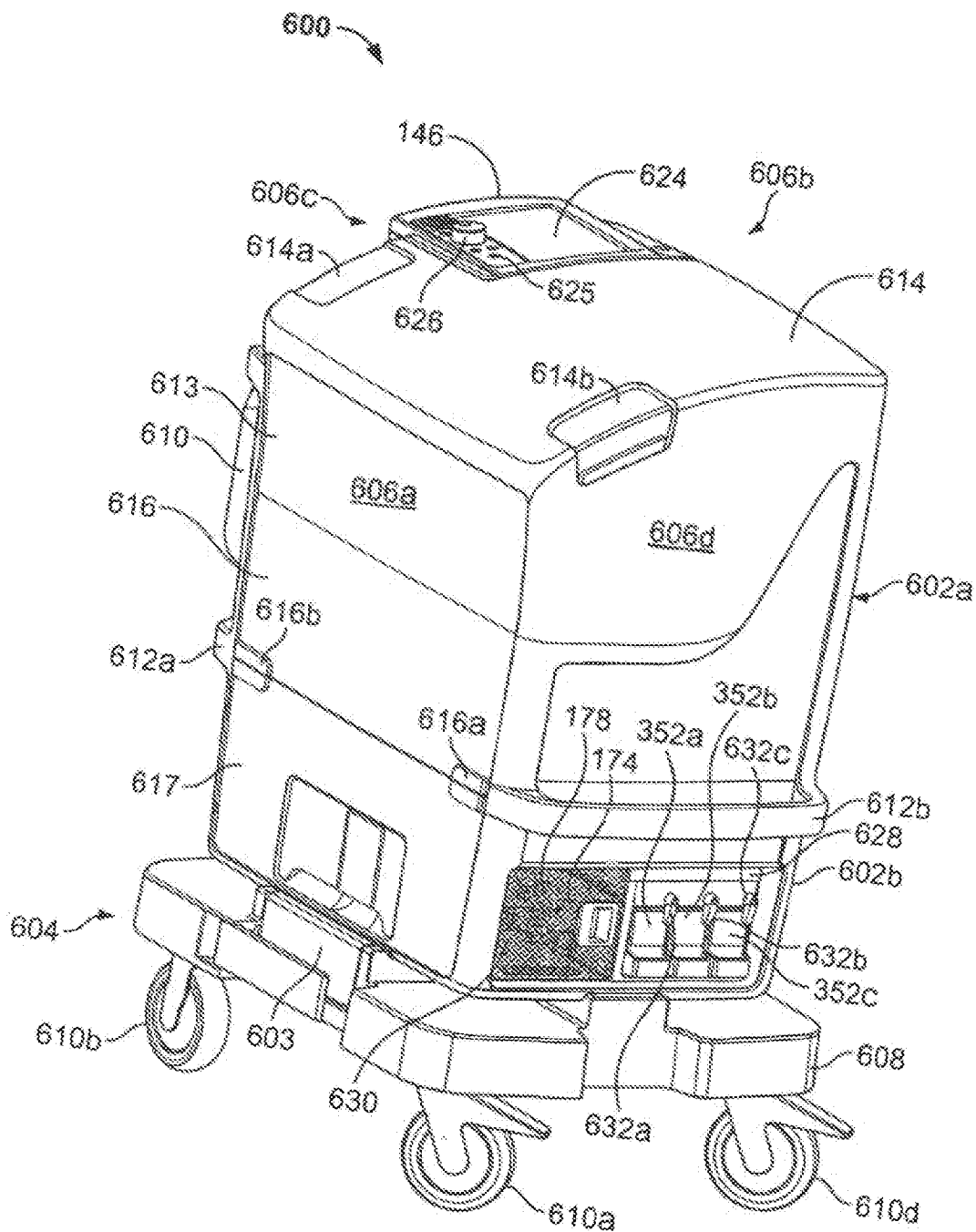

FIG. 18B

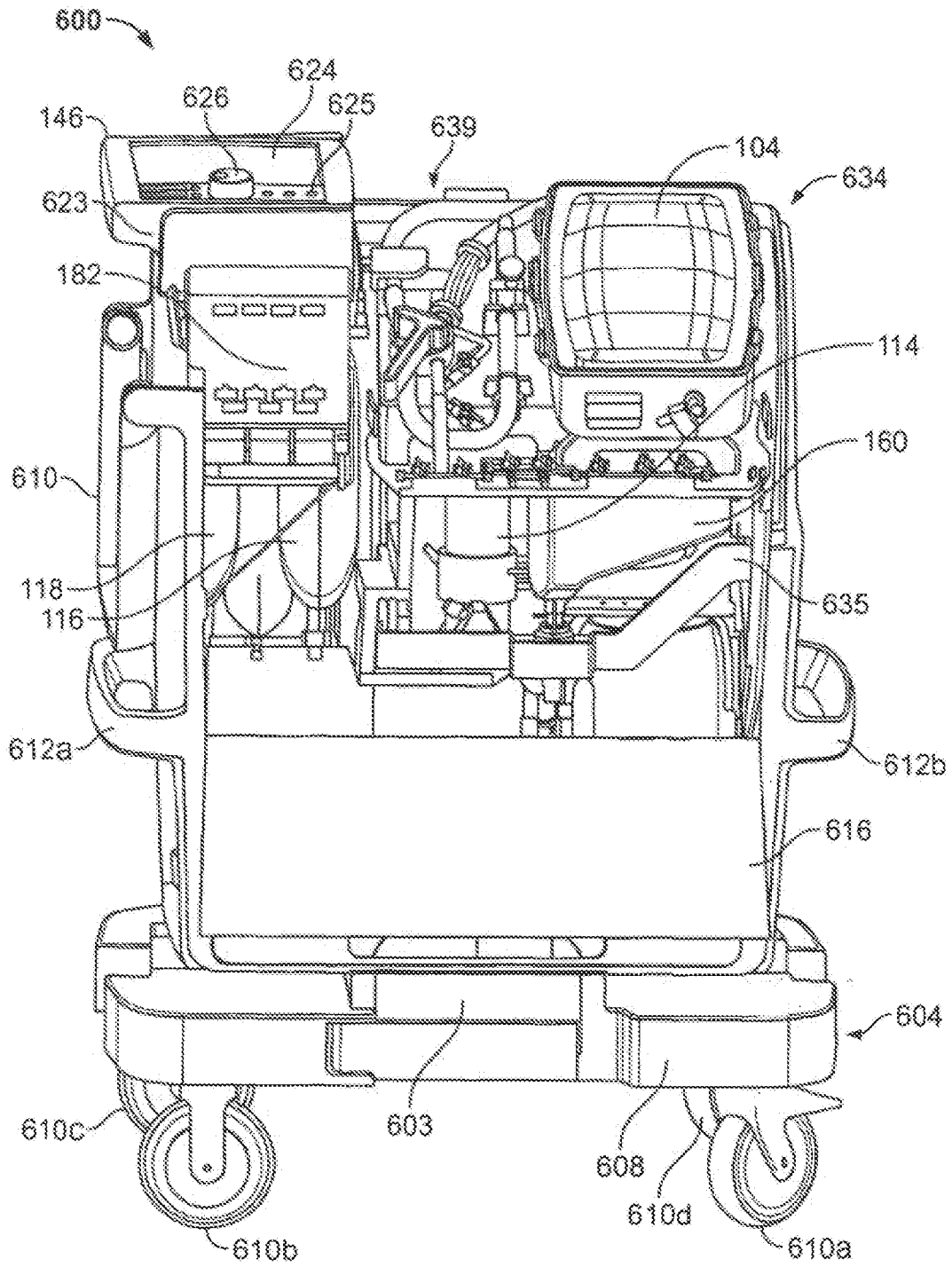

FIG. 19A

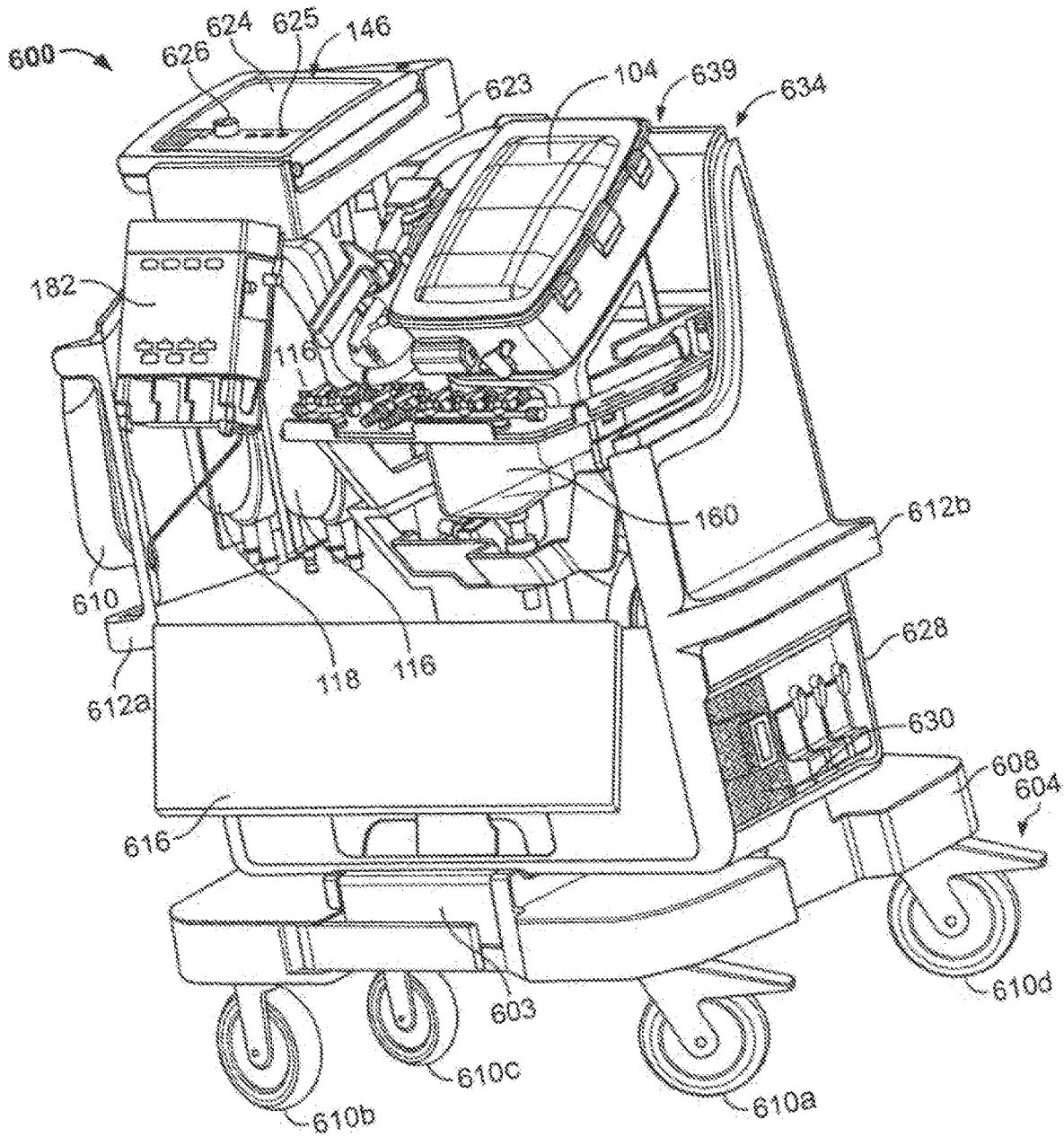

FIG. 19B

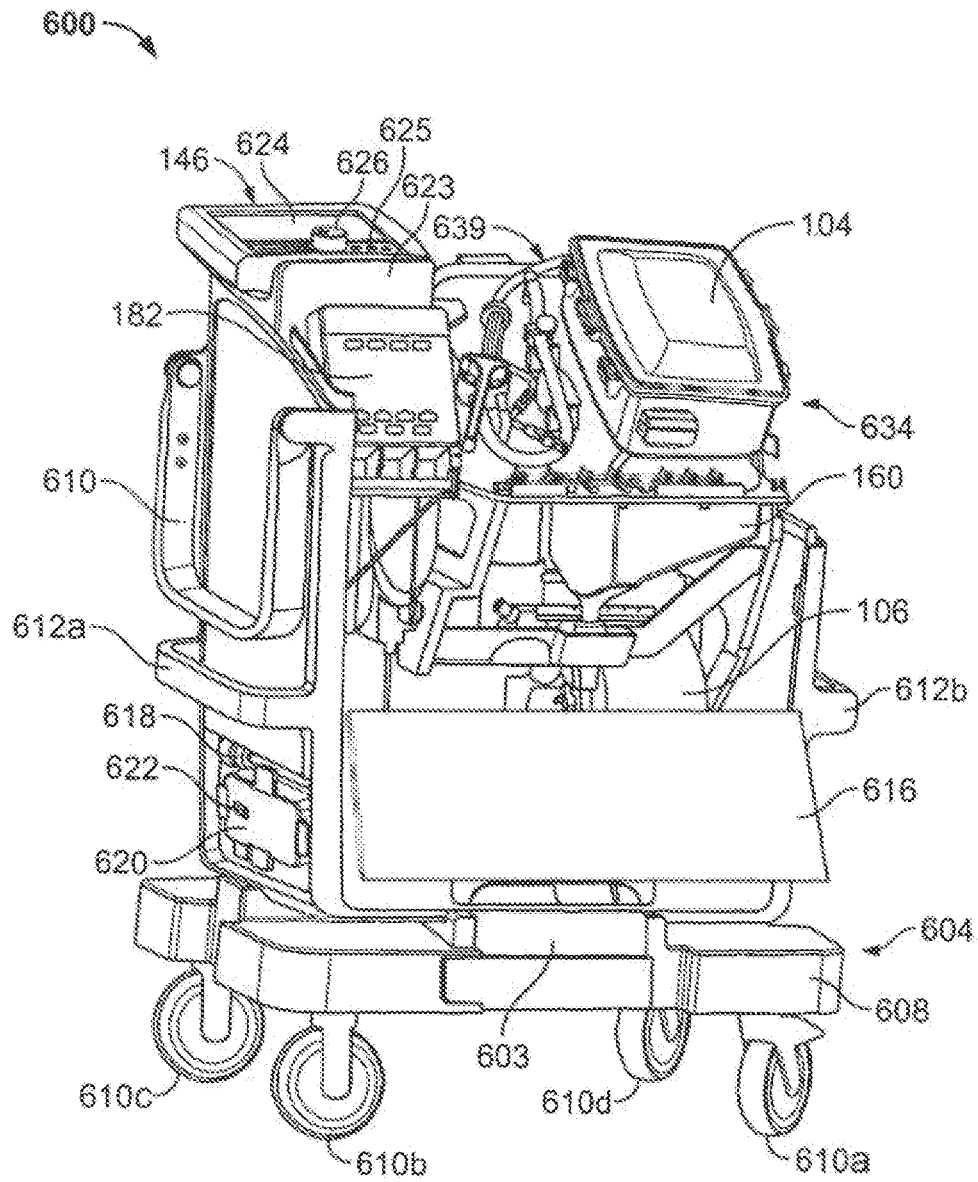

FIG. 19C

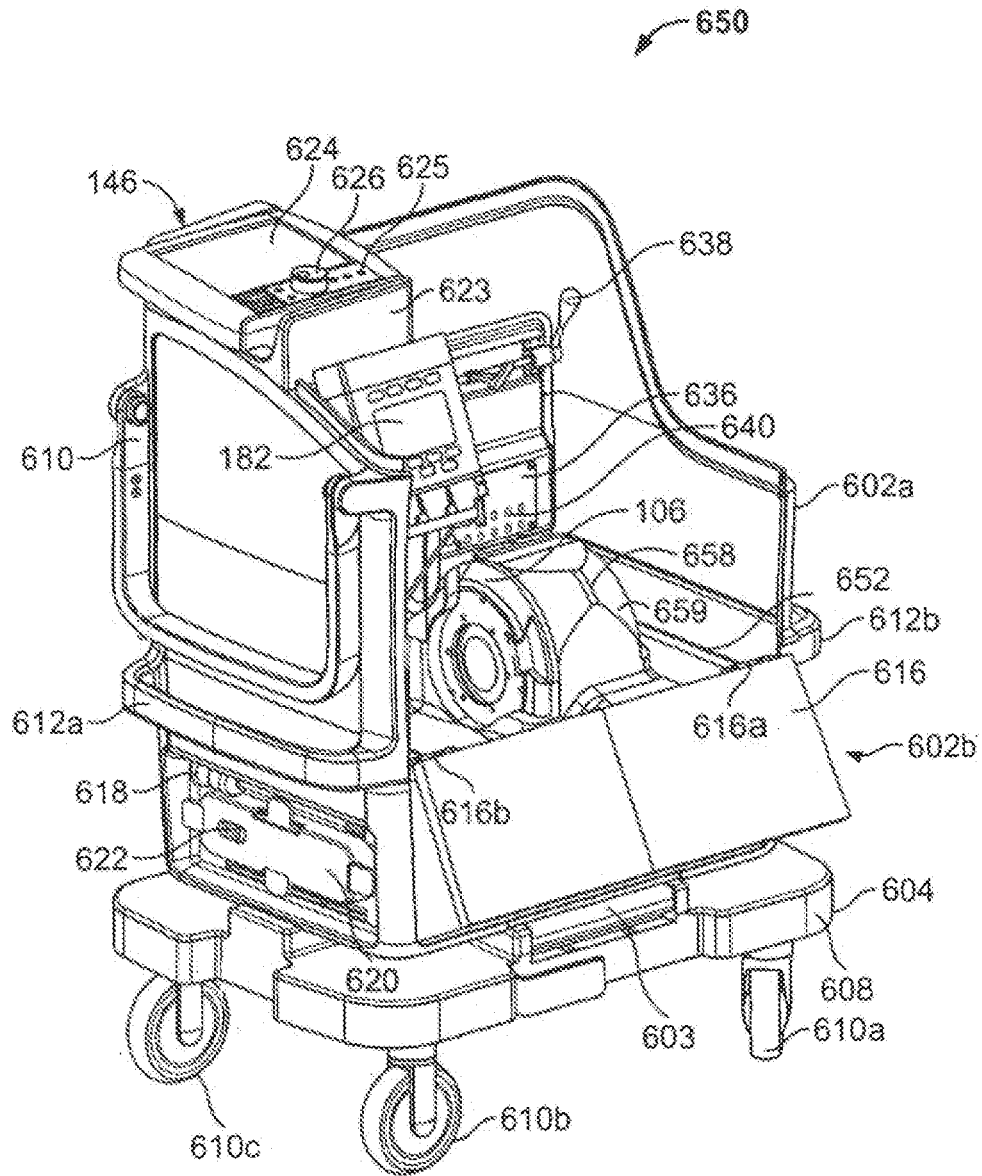

FIG. 20A

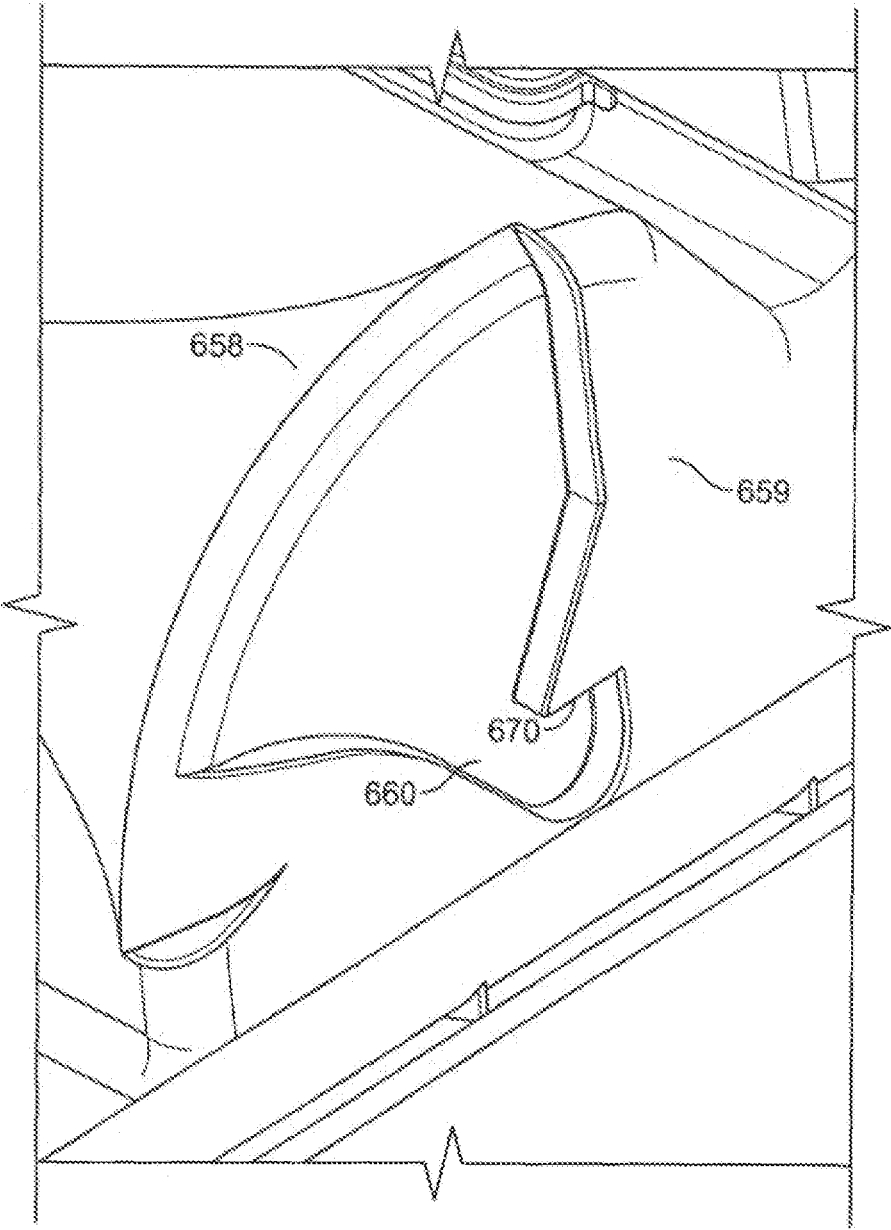

FIG. 20B

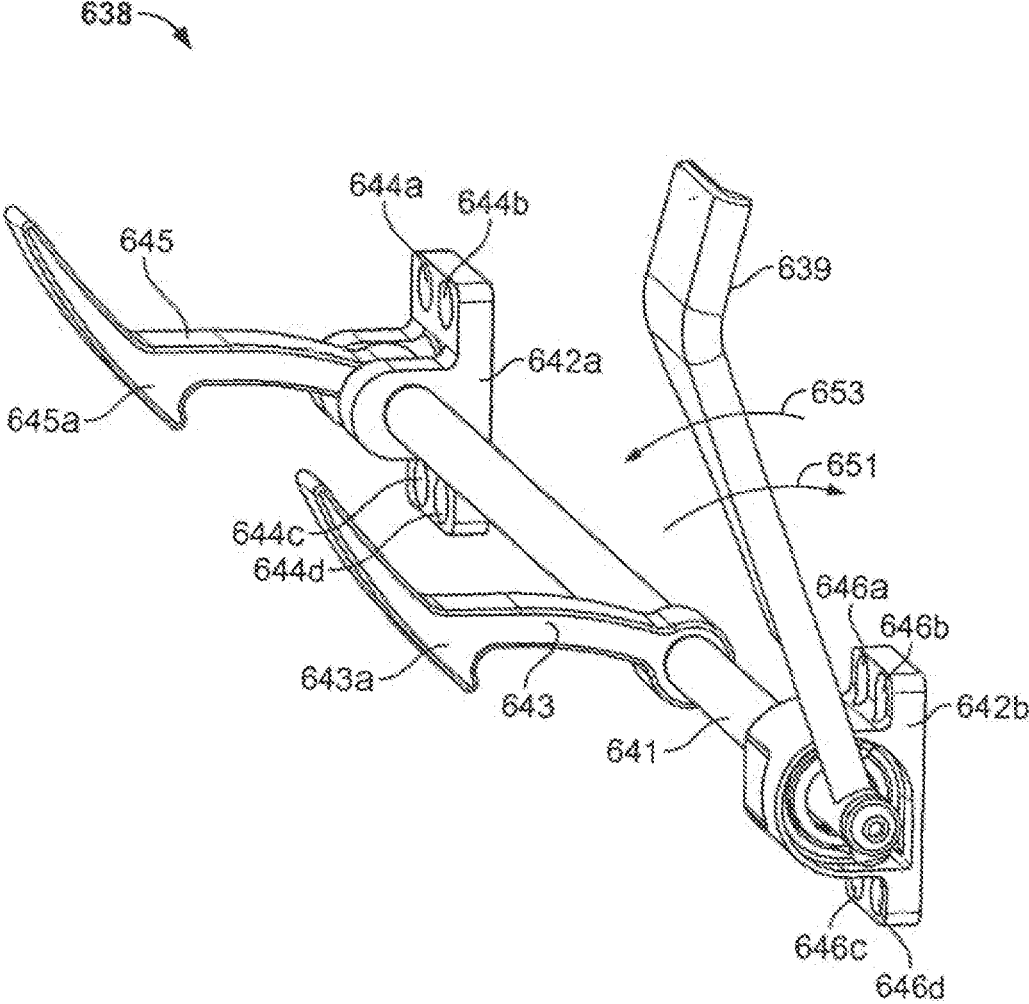

FIG. 21A

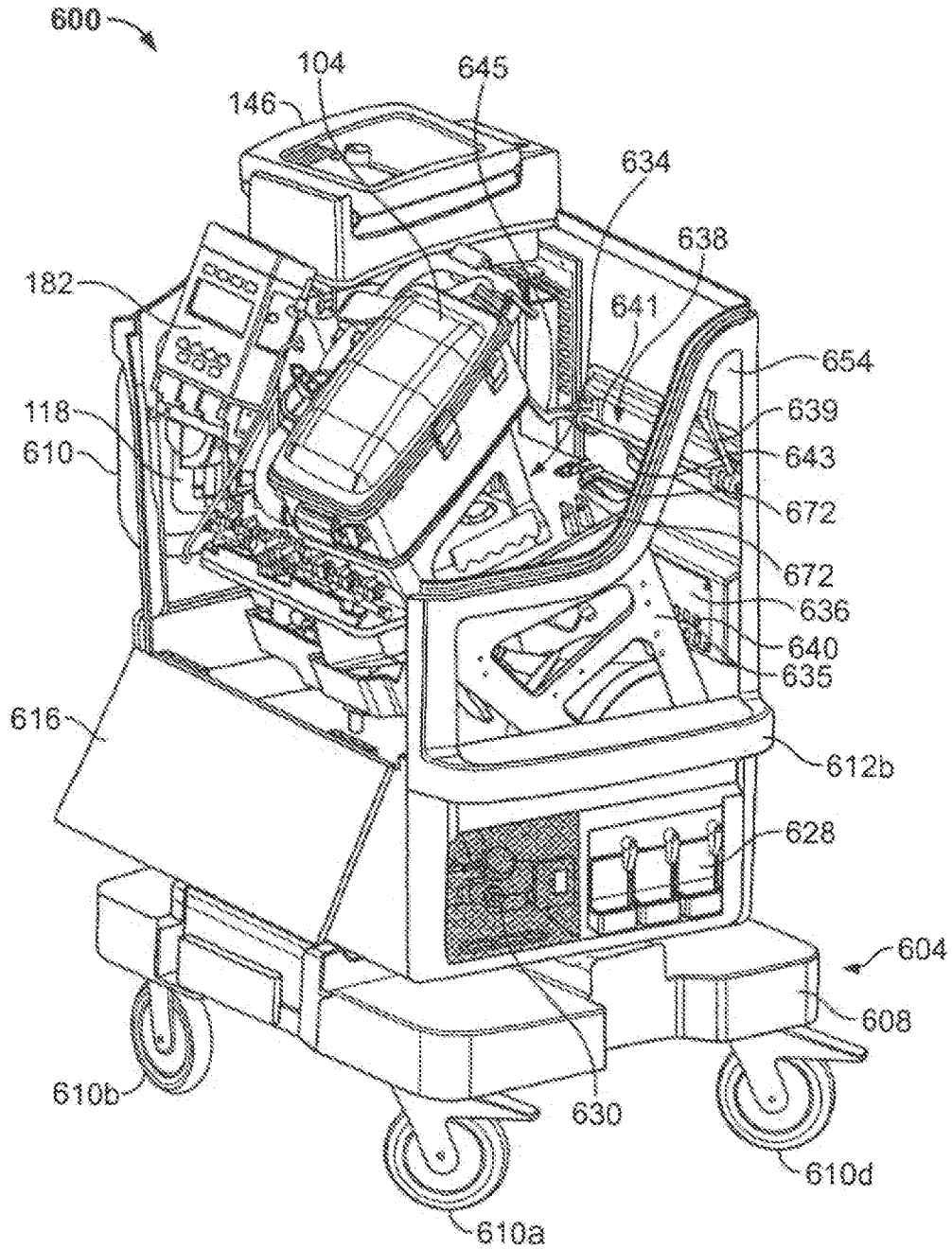

FIG. 21B

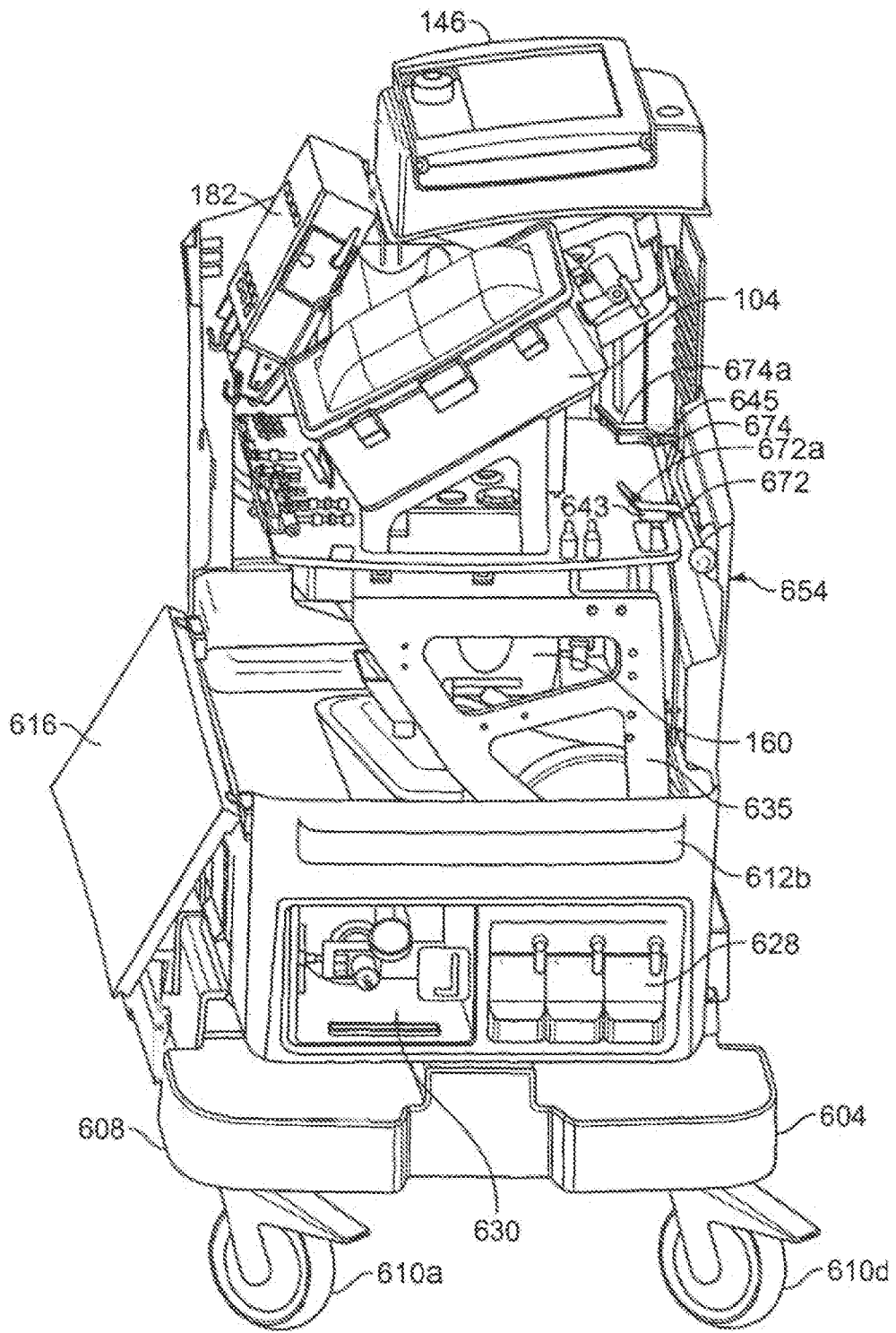

FIG. 21C

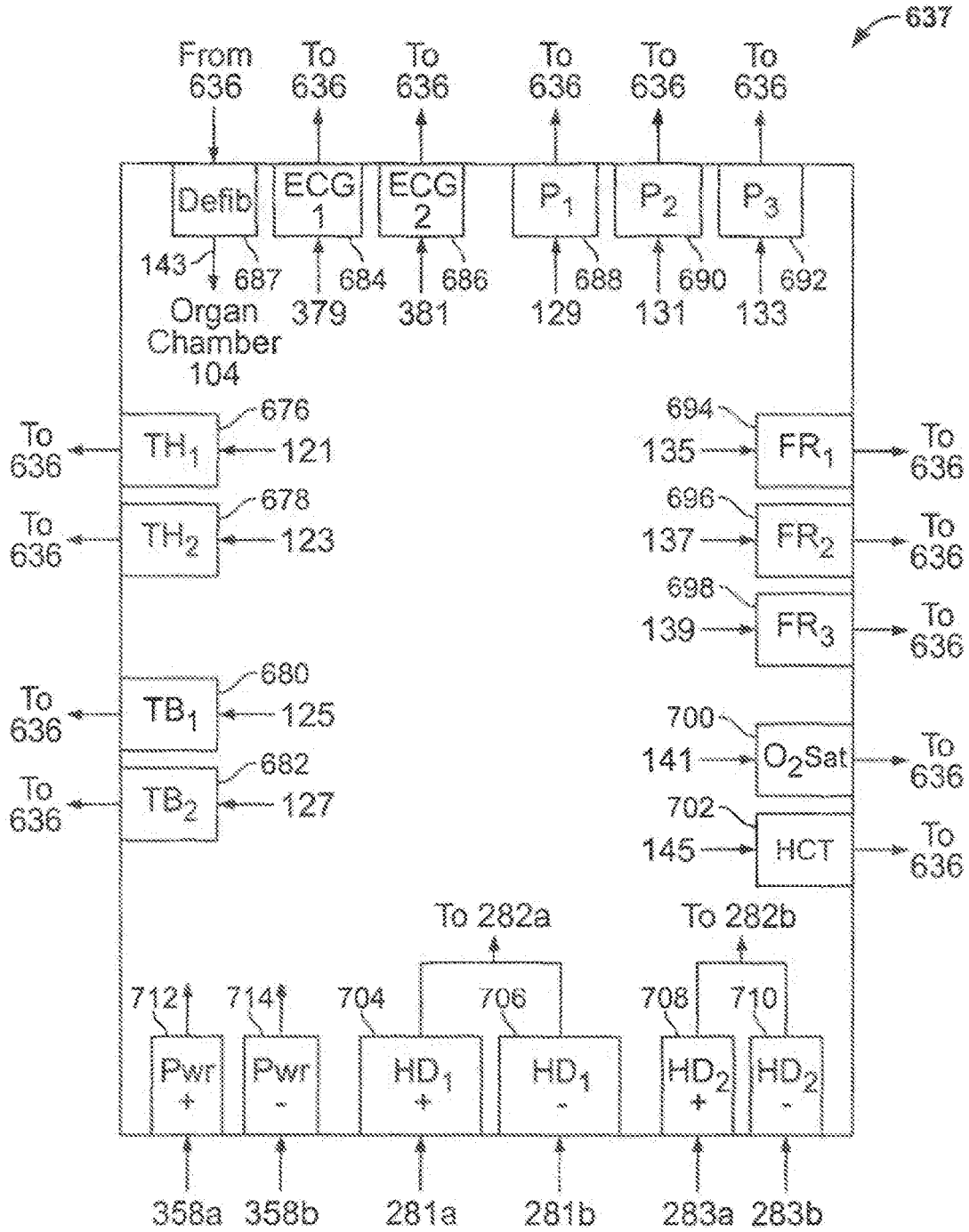

FIG. 22A

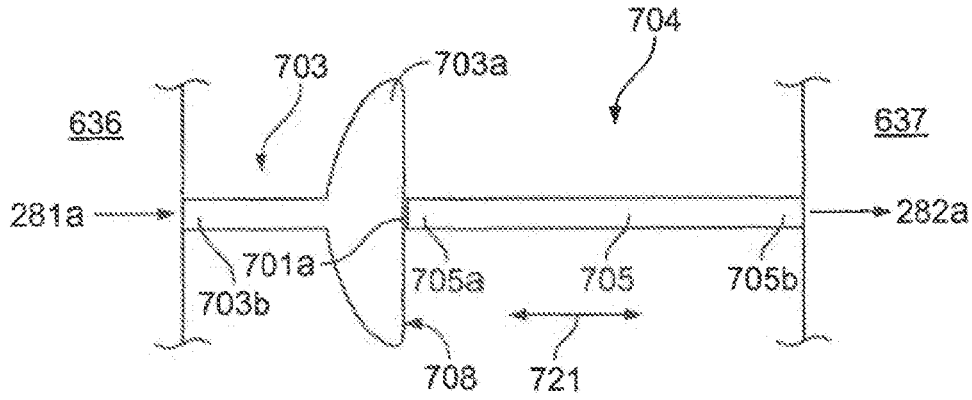

FIG. 22B

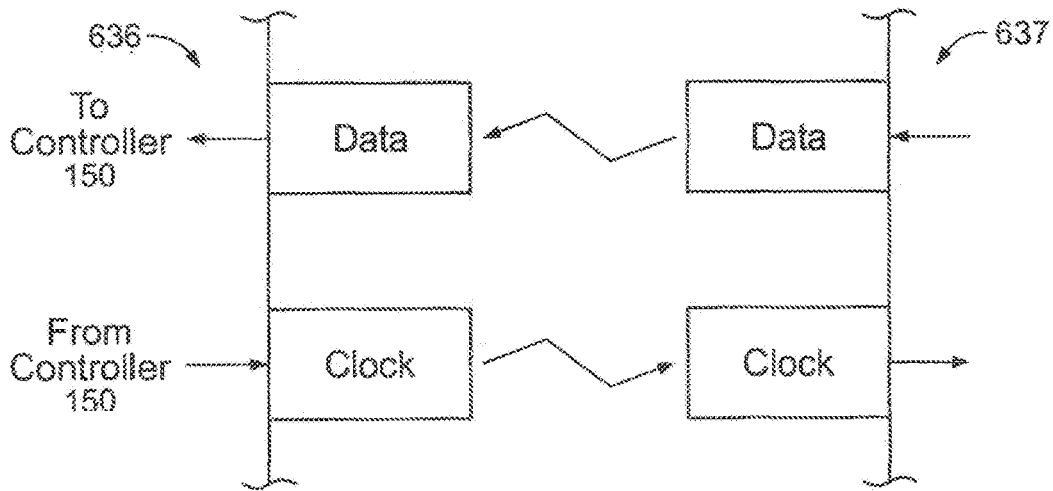

FIG. 22C

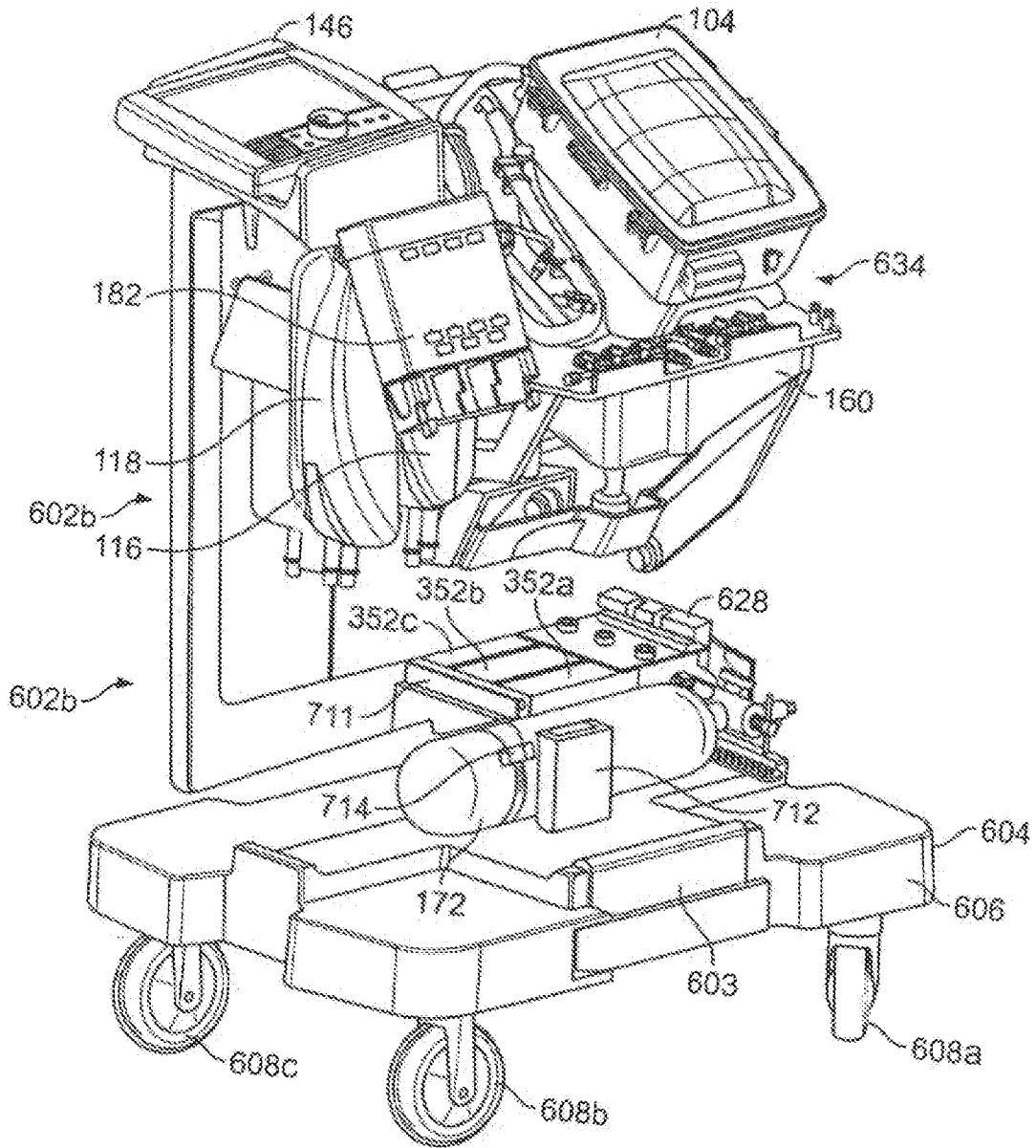

FIG. 23A

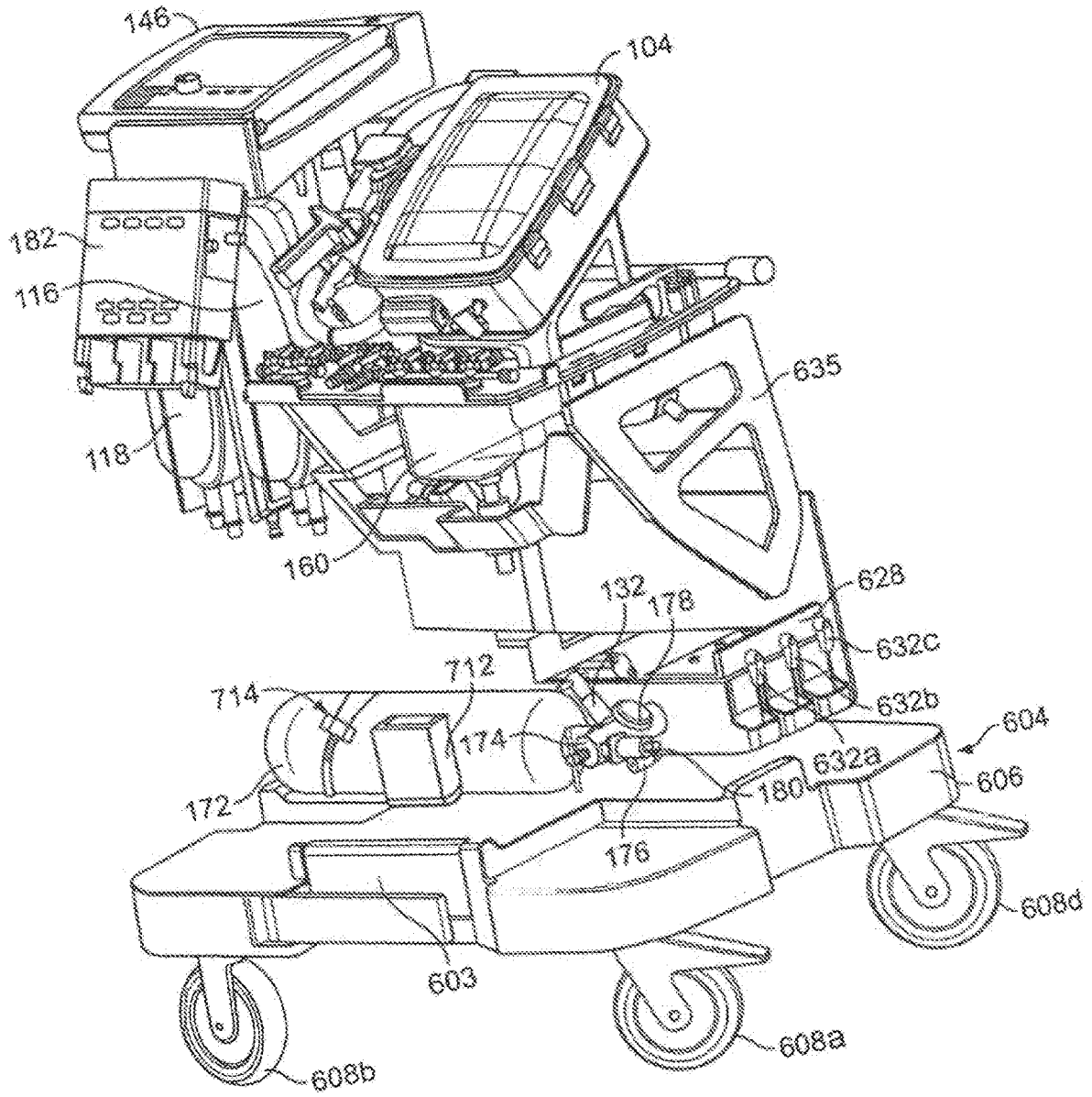

FIG. 23B

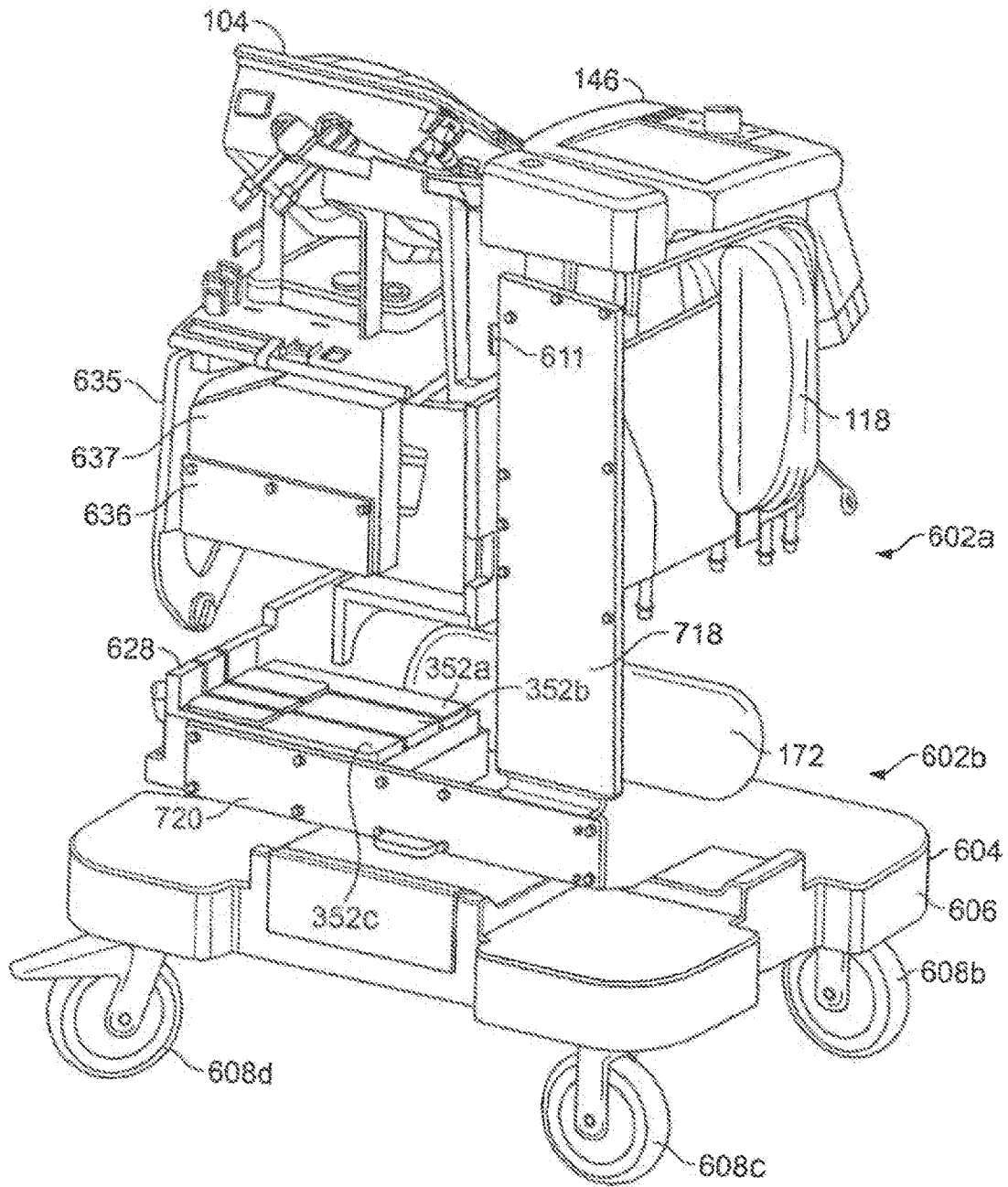

FIG. 23C

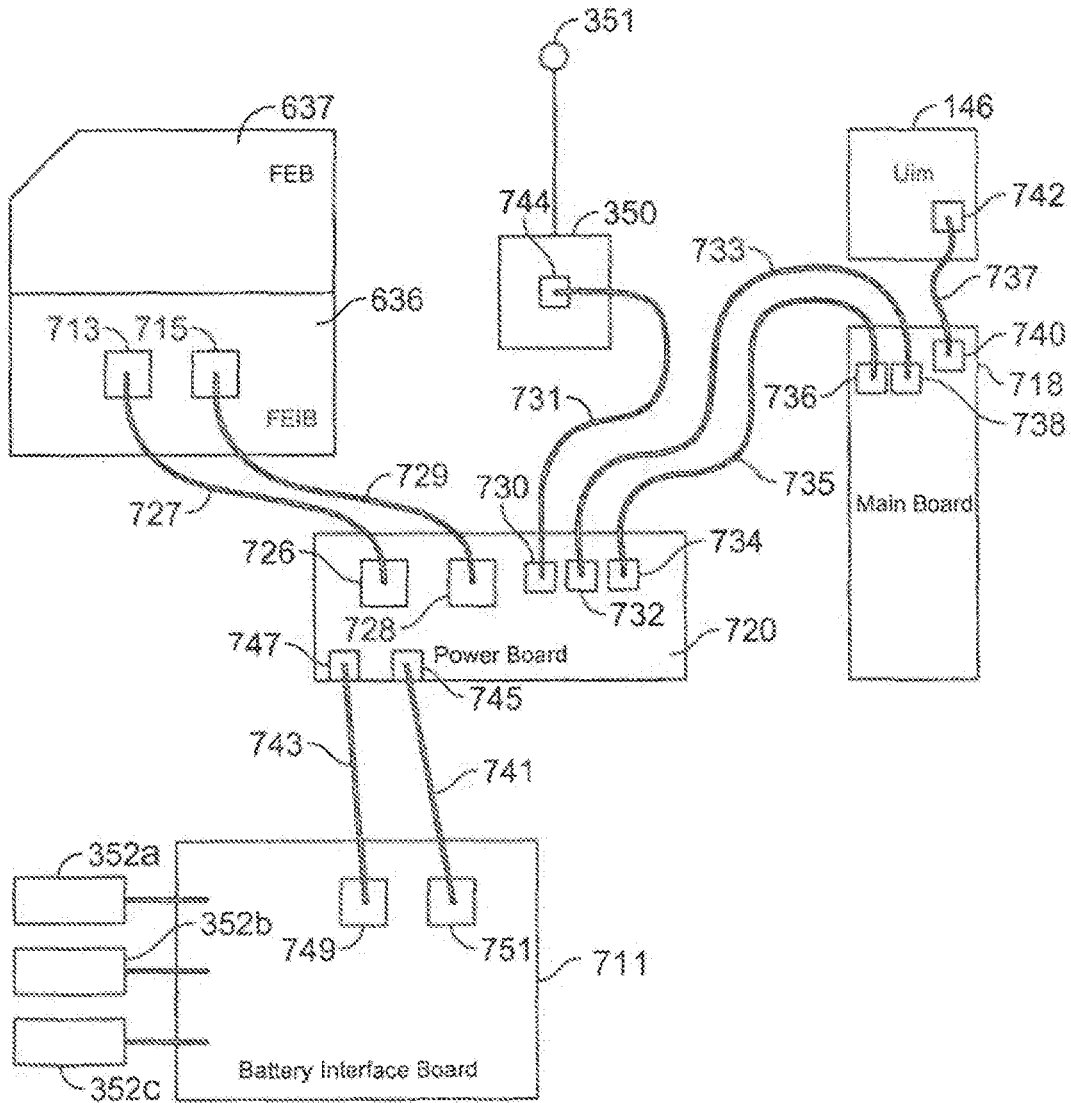

FIG. 23D

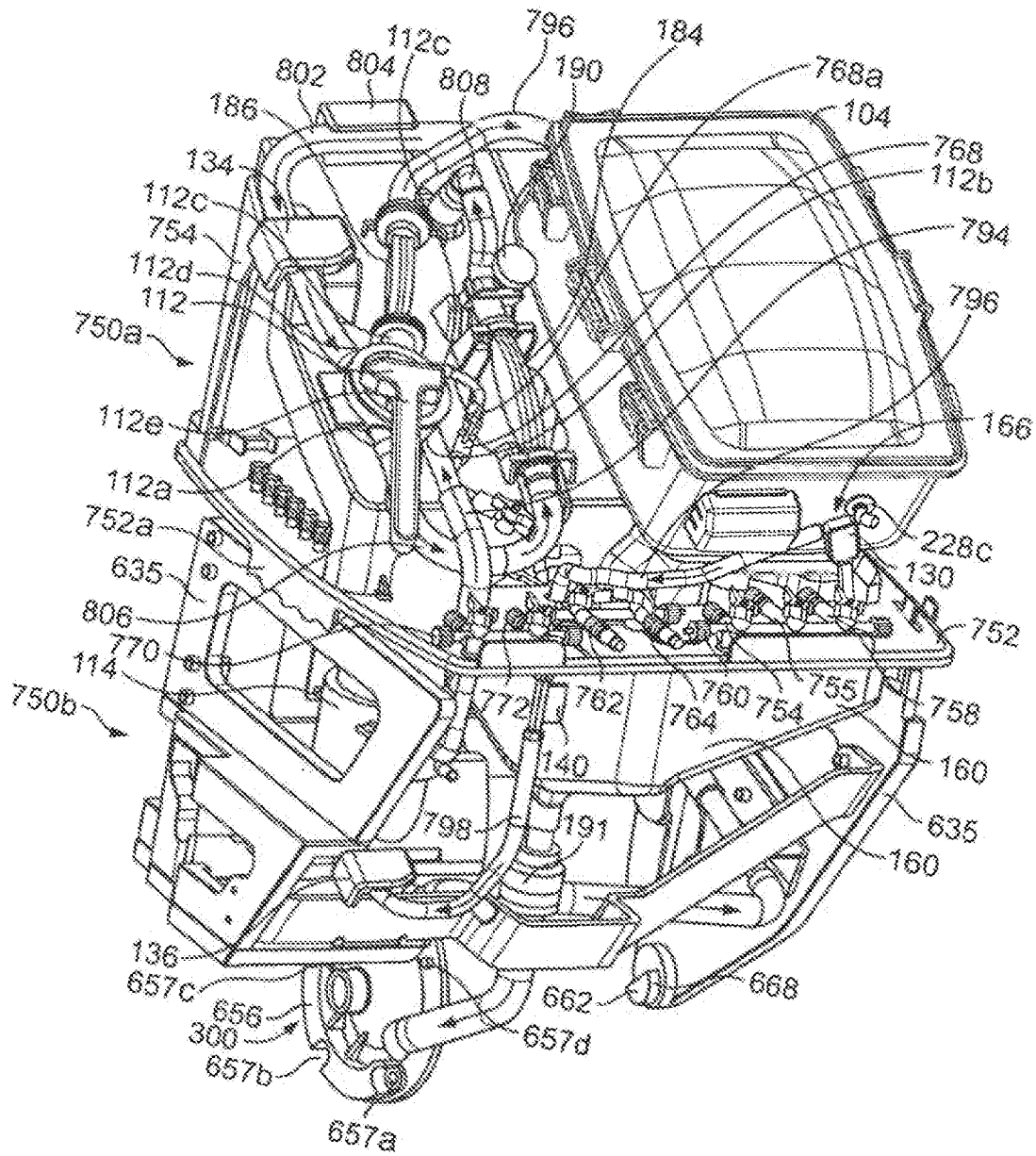

FIG. 24A

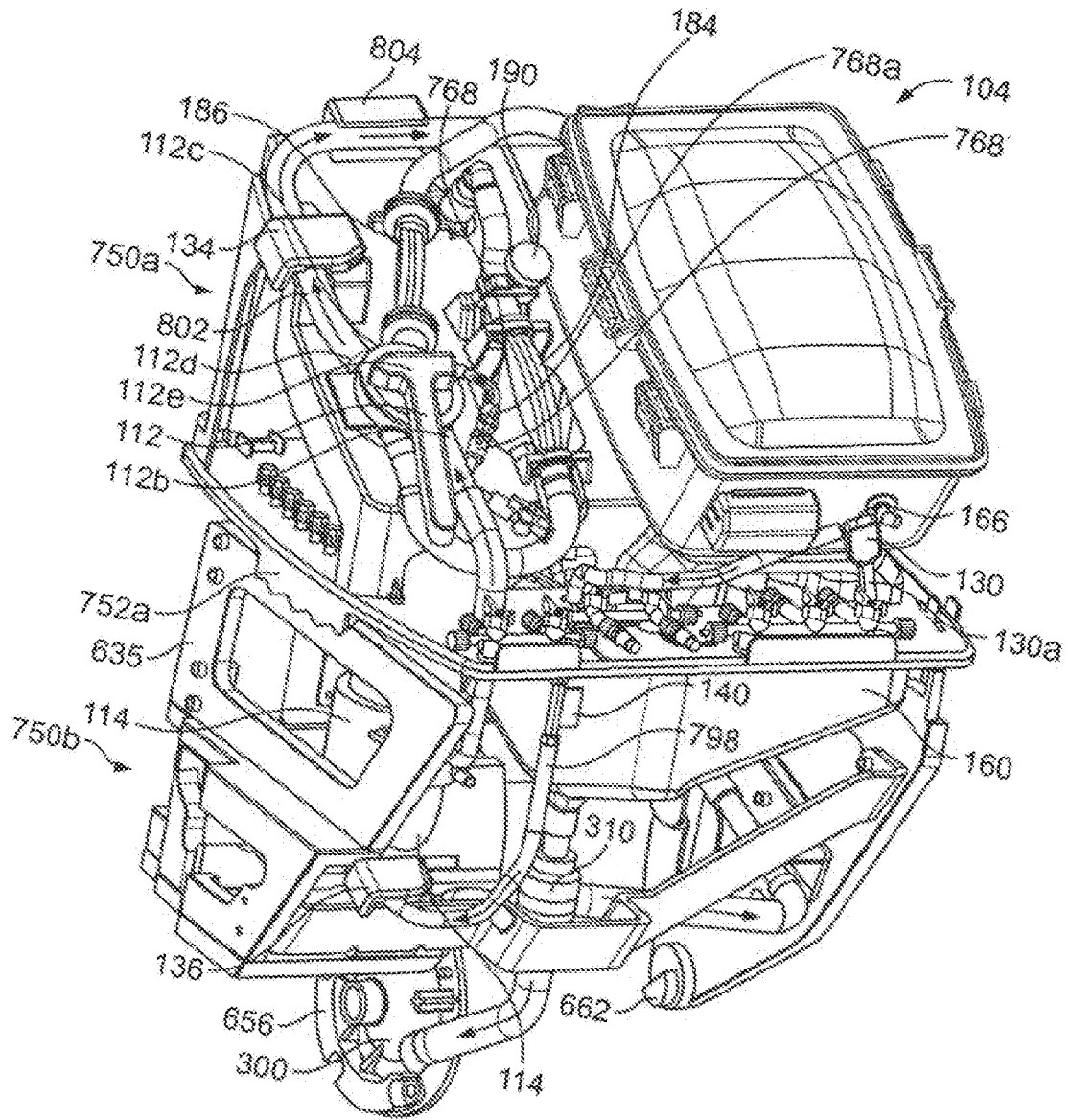

FIG. 24B

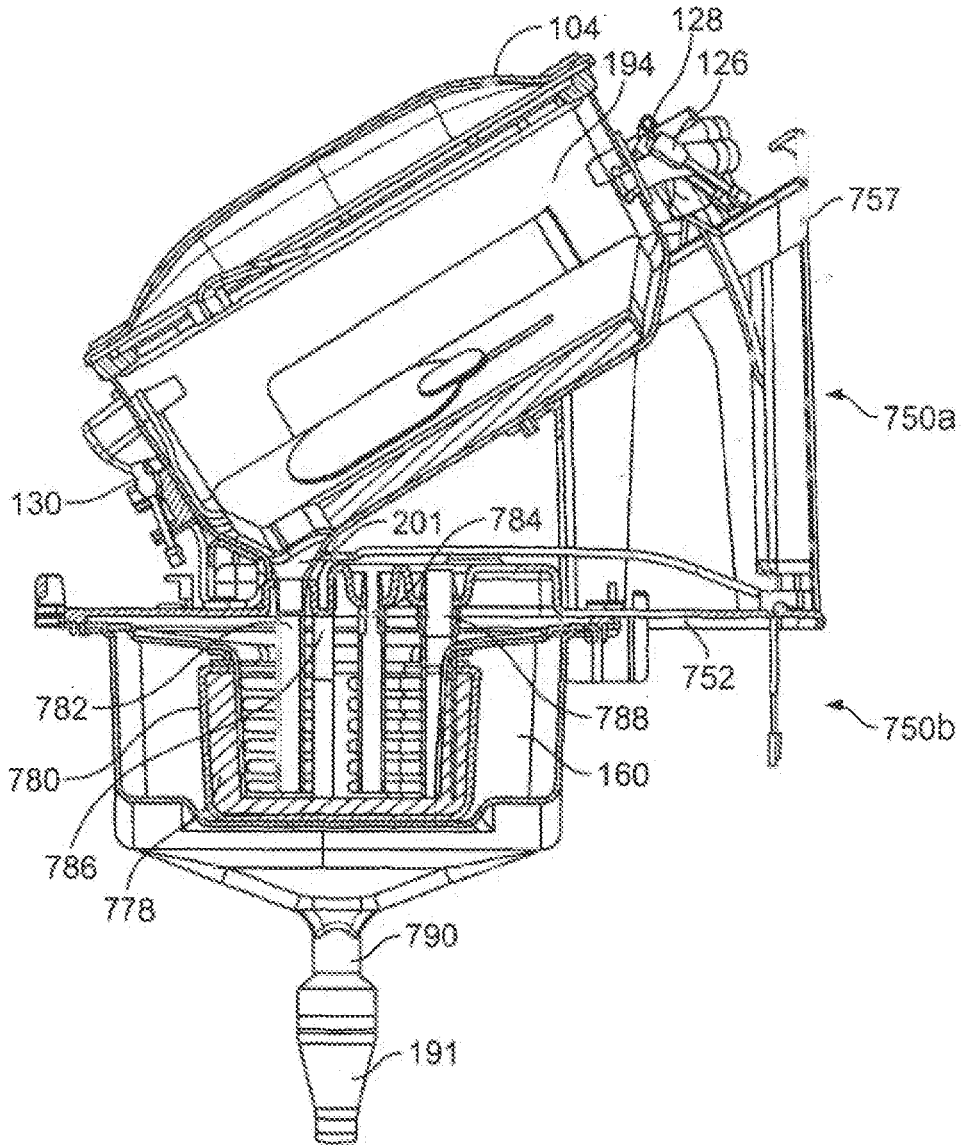

FIG. 24C

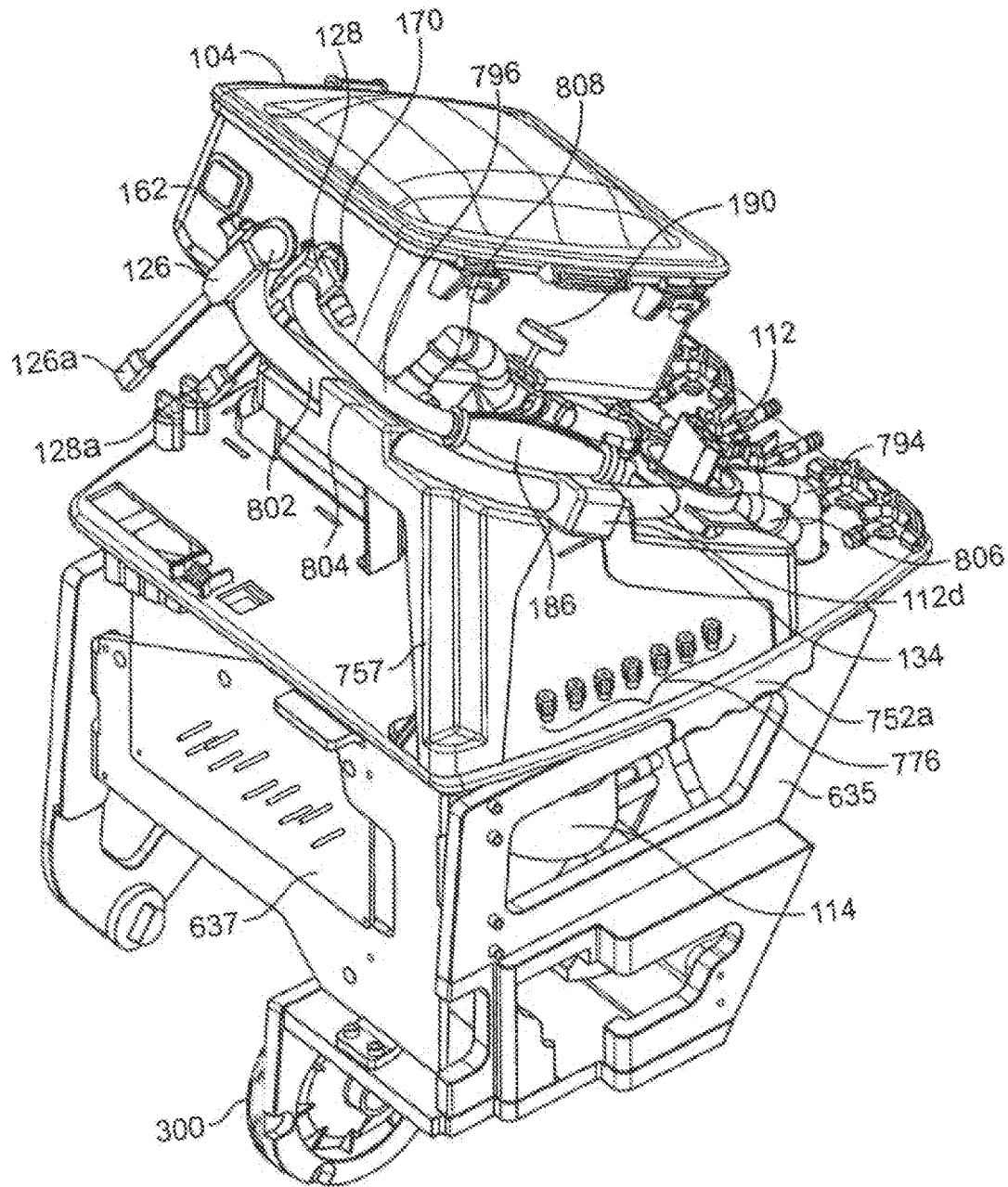

FIG. 24D

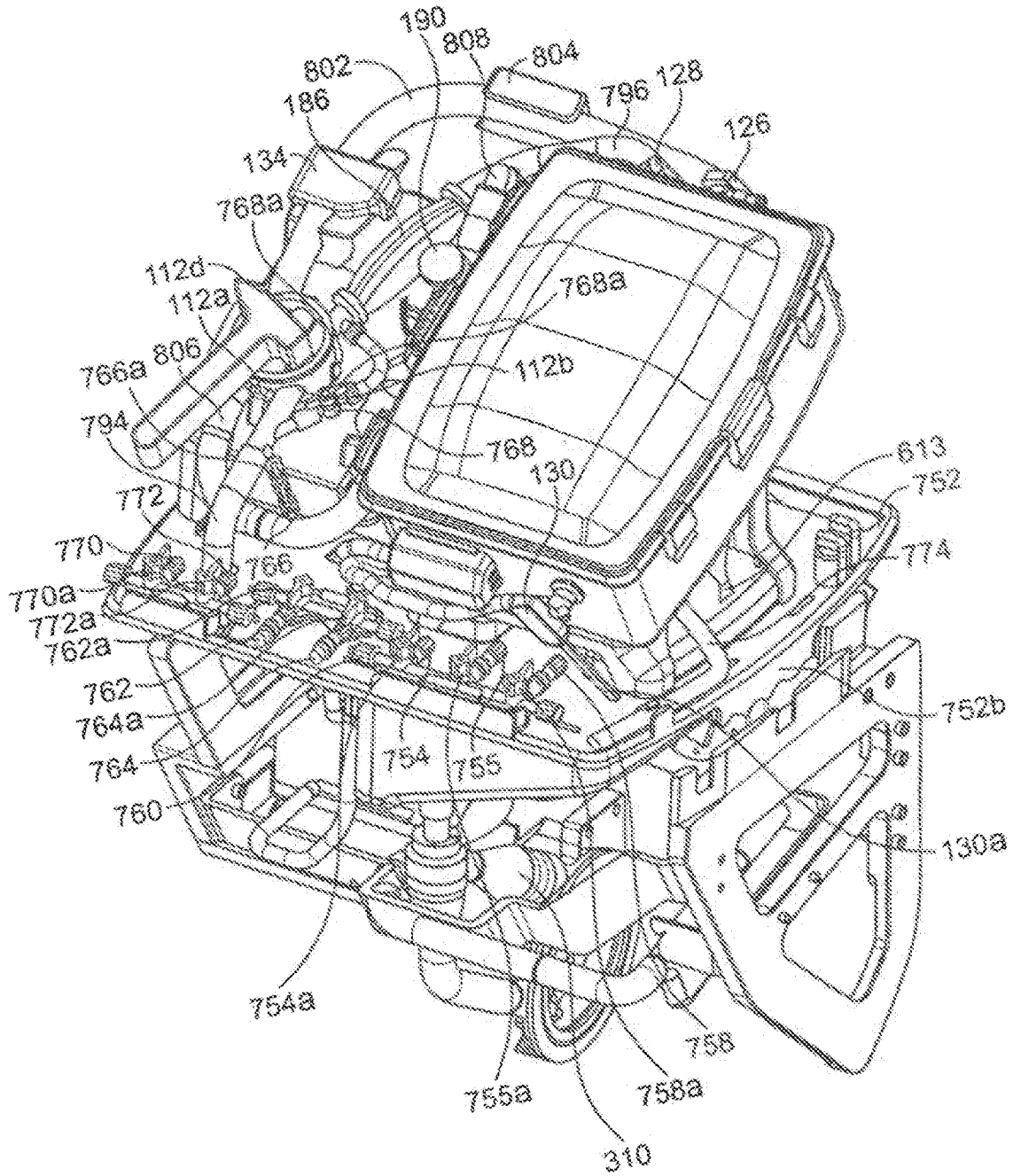

FIG. 24E

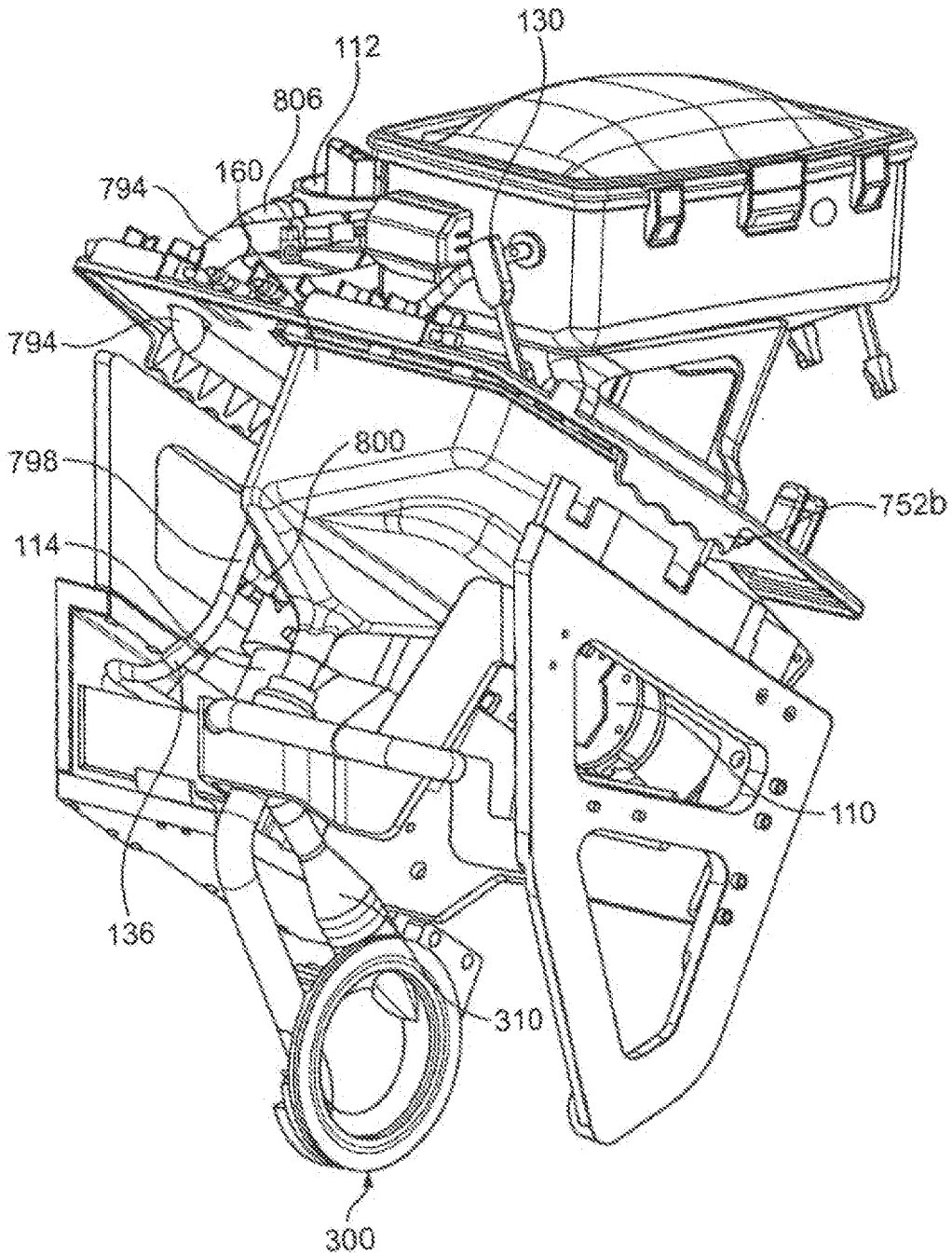

FIG. 25A

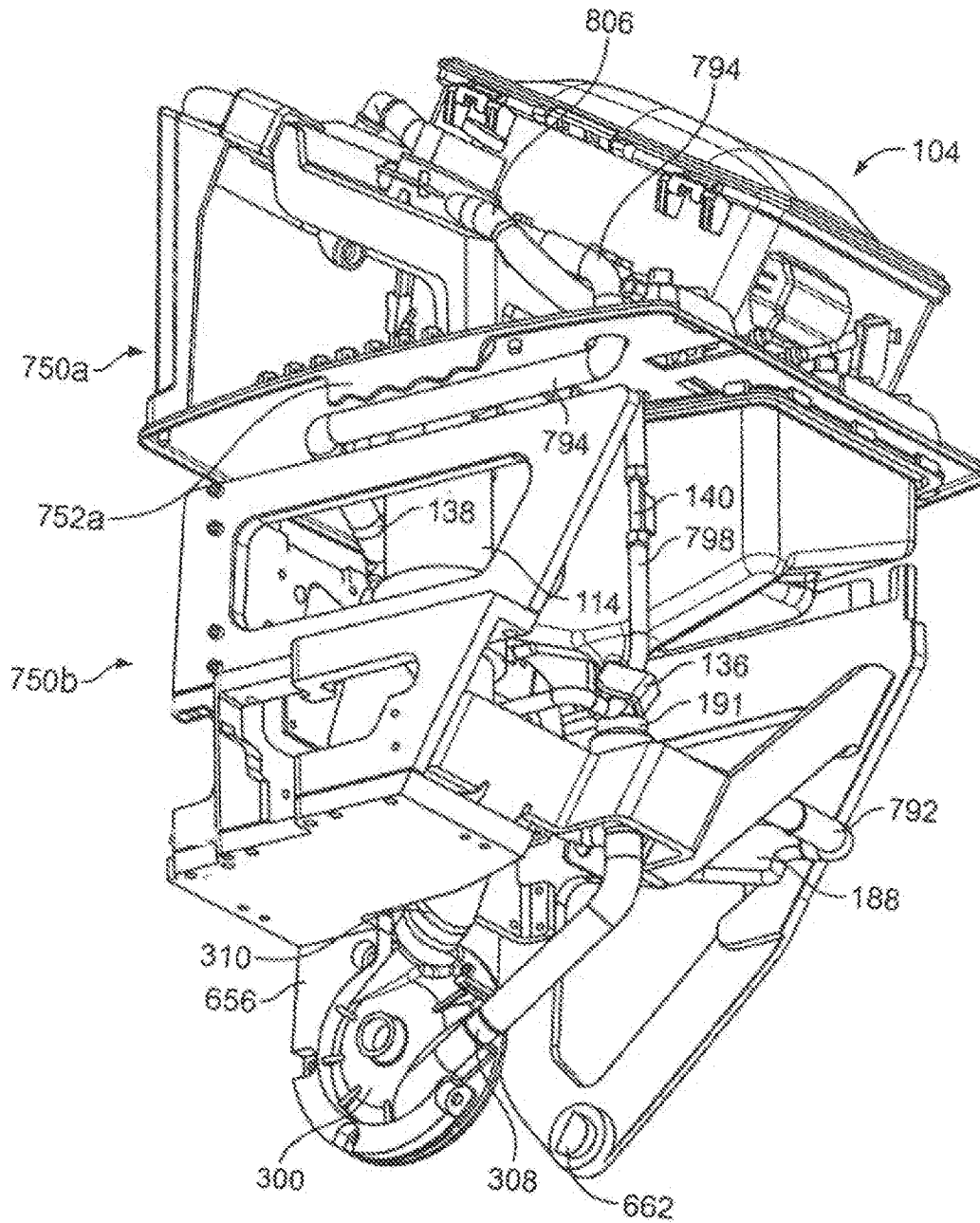

FIG. 25B

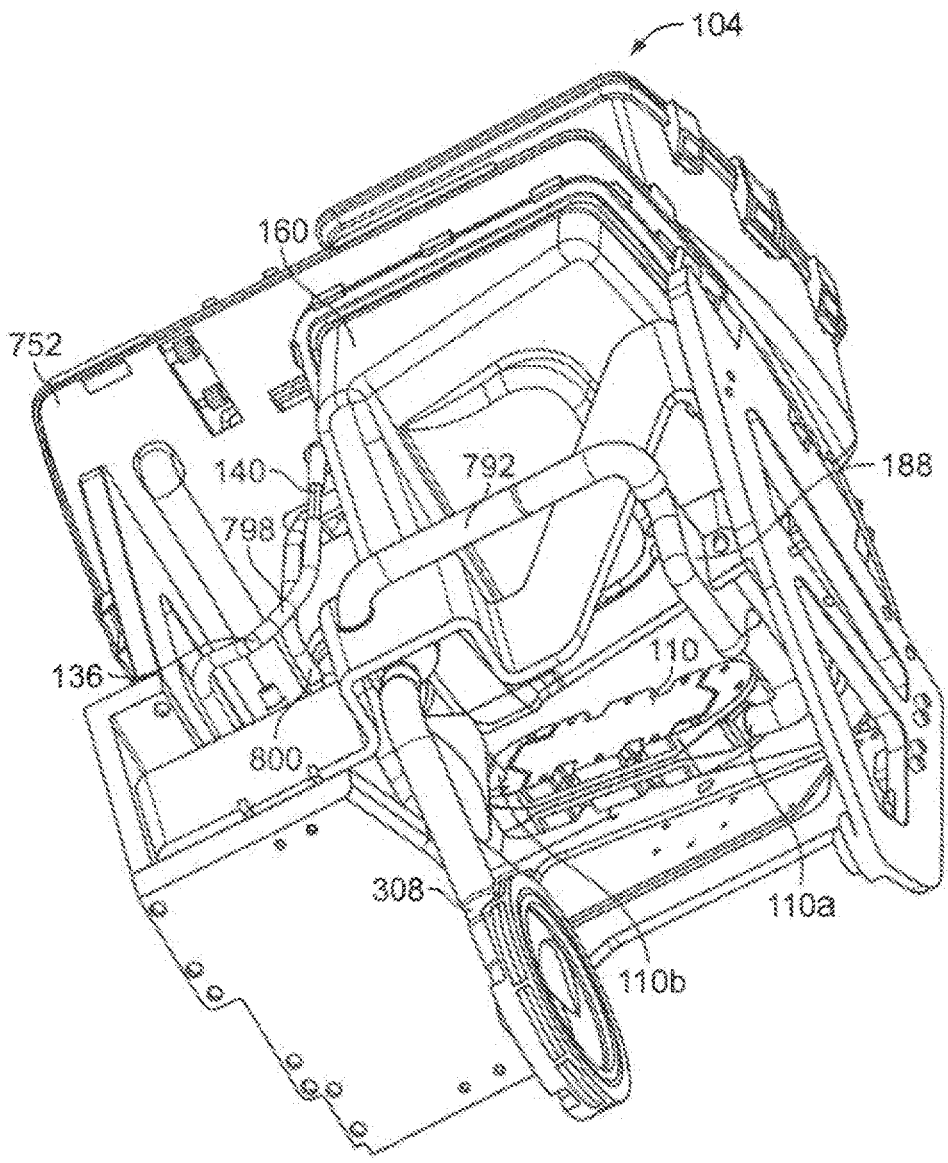

FIG. 25C

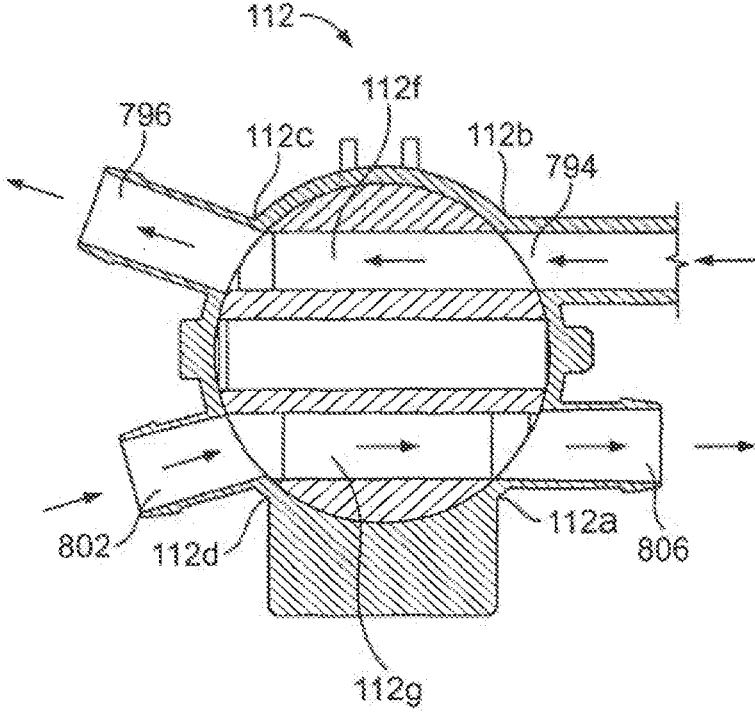

FIG. 26A

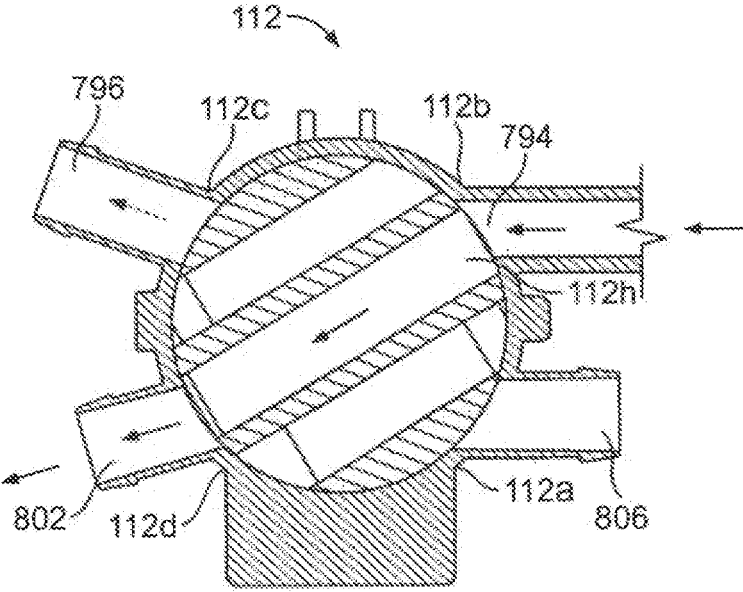

FIG. 26B

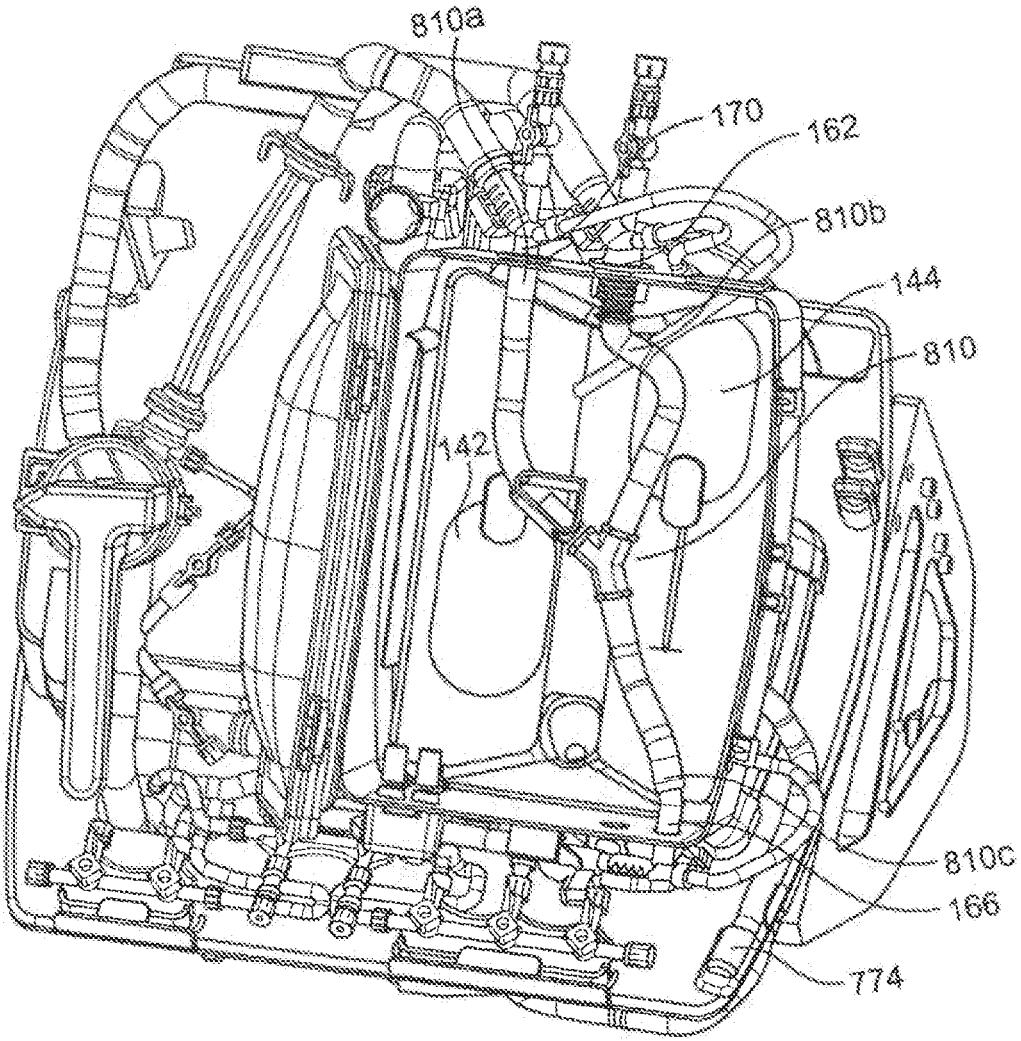

FIG. 27A

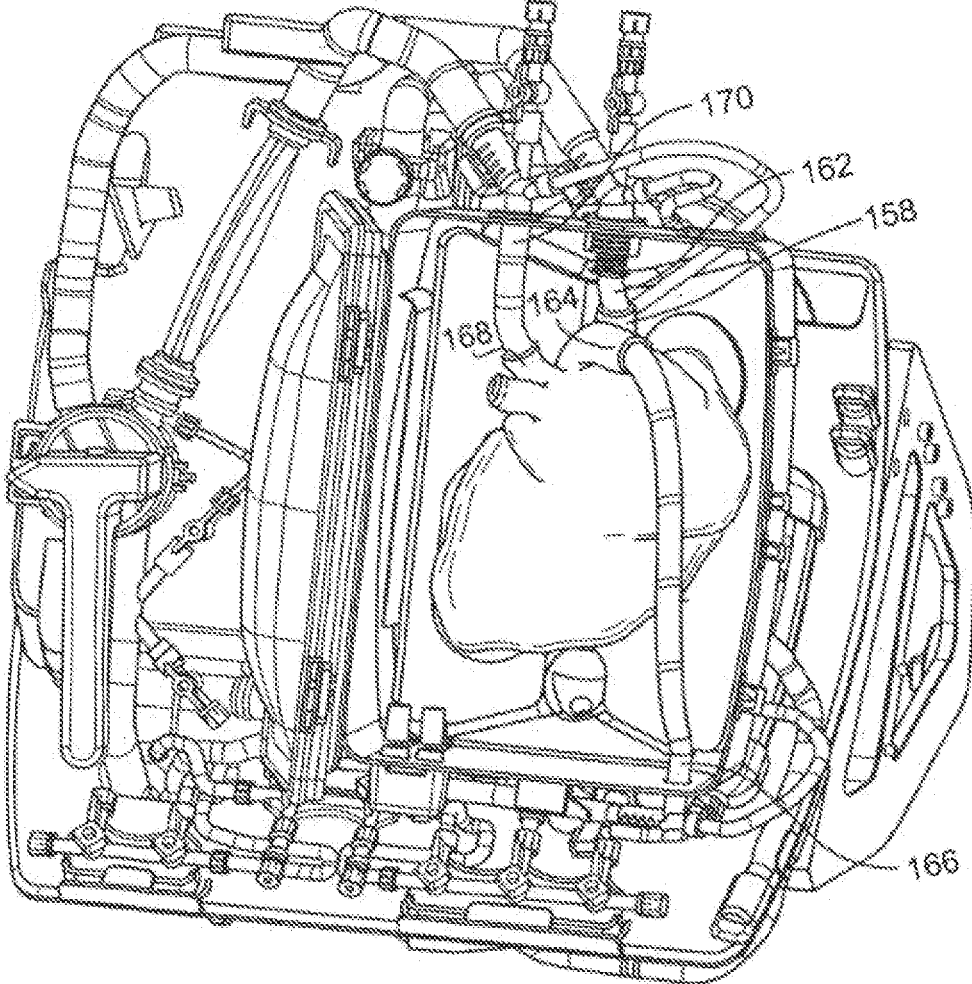

FIG. 27B

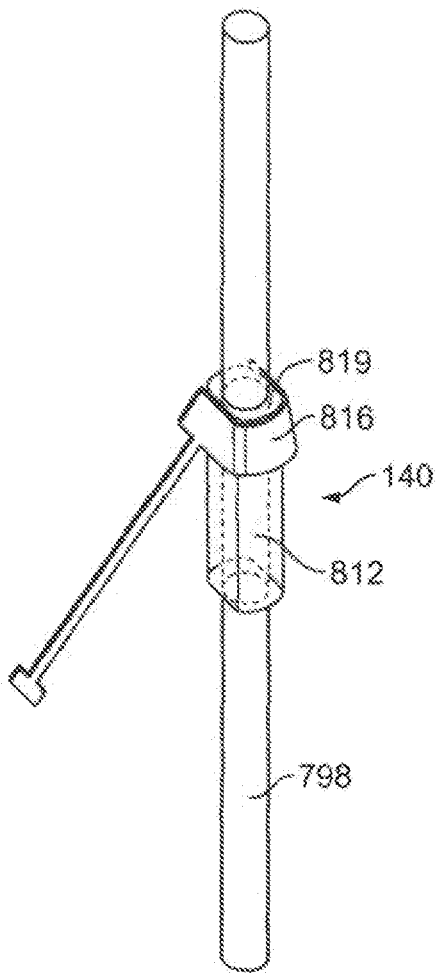

FIG. 28A

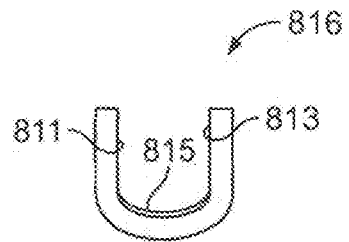

FIG. 28C

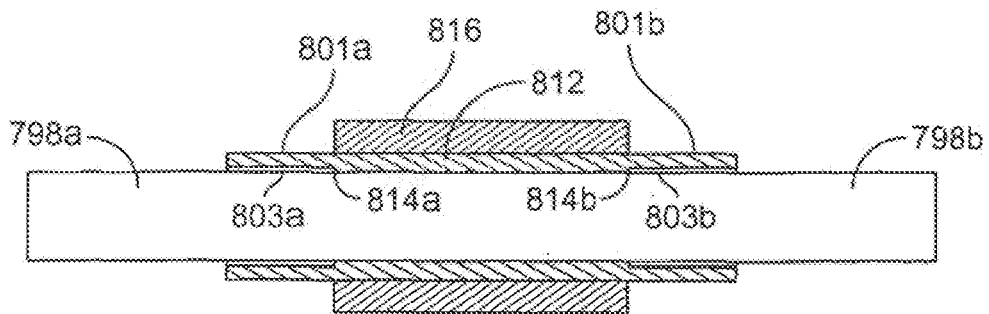
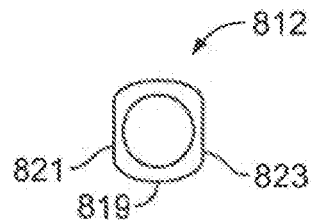

FIG. 28B

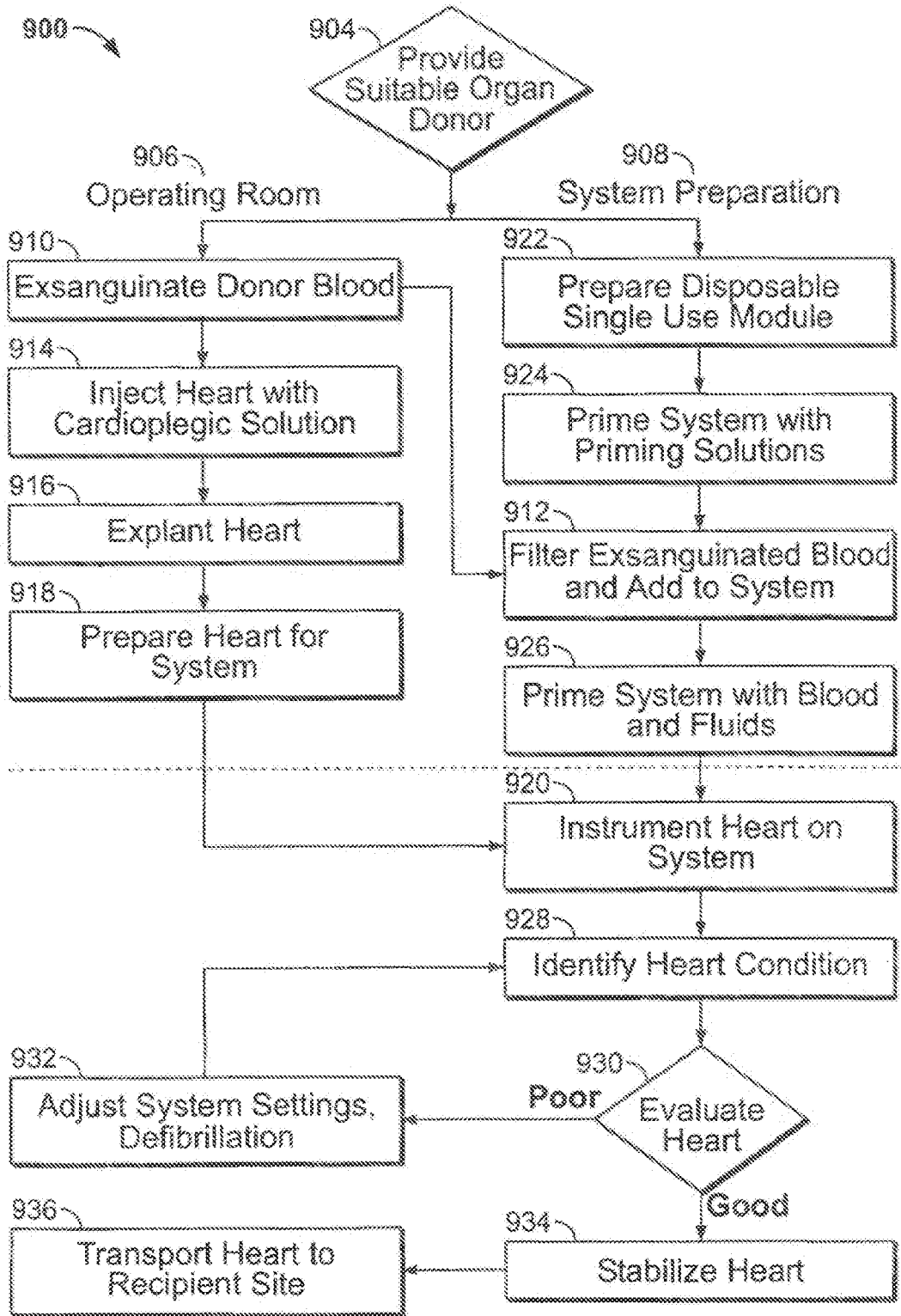

FIG. 29A

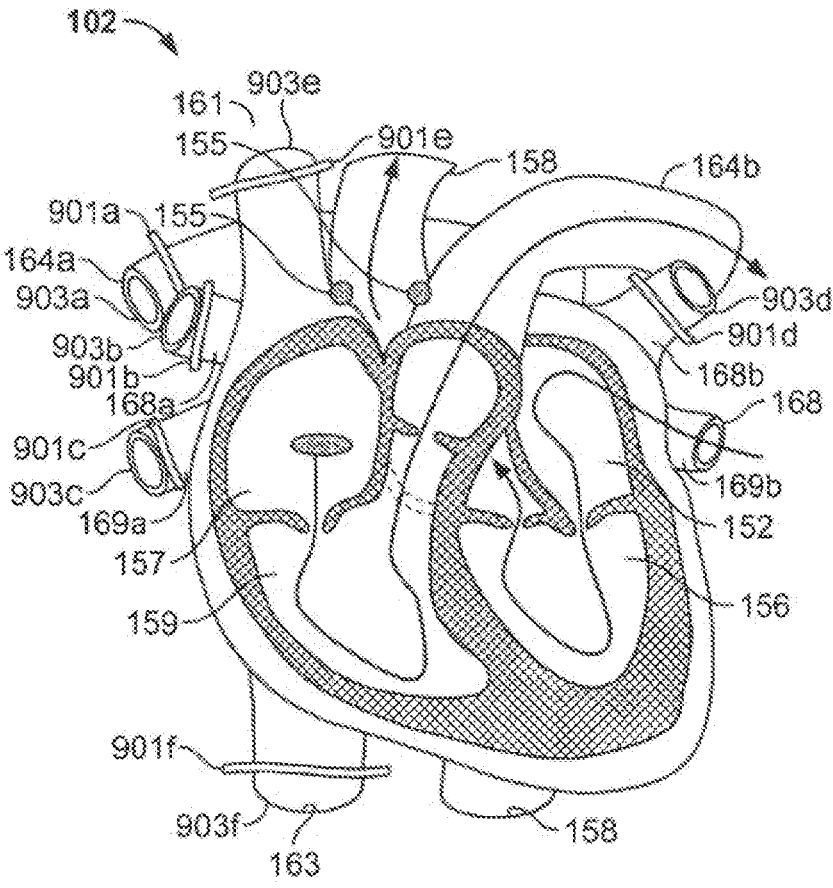

FIG. 29B

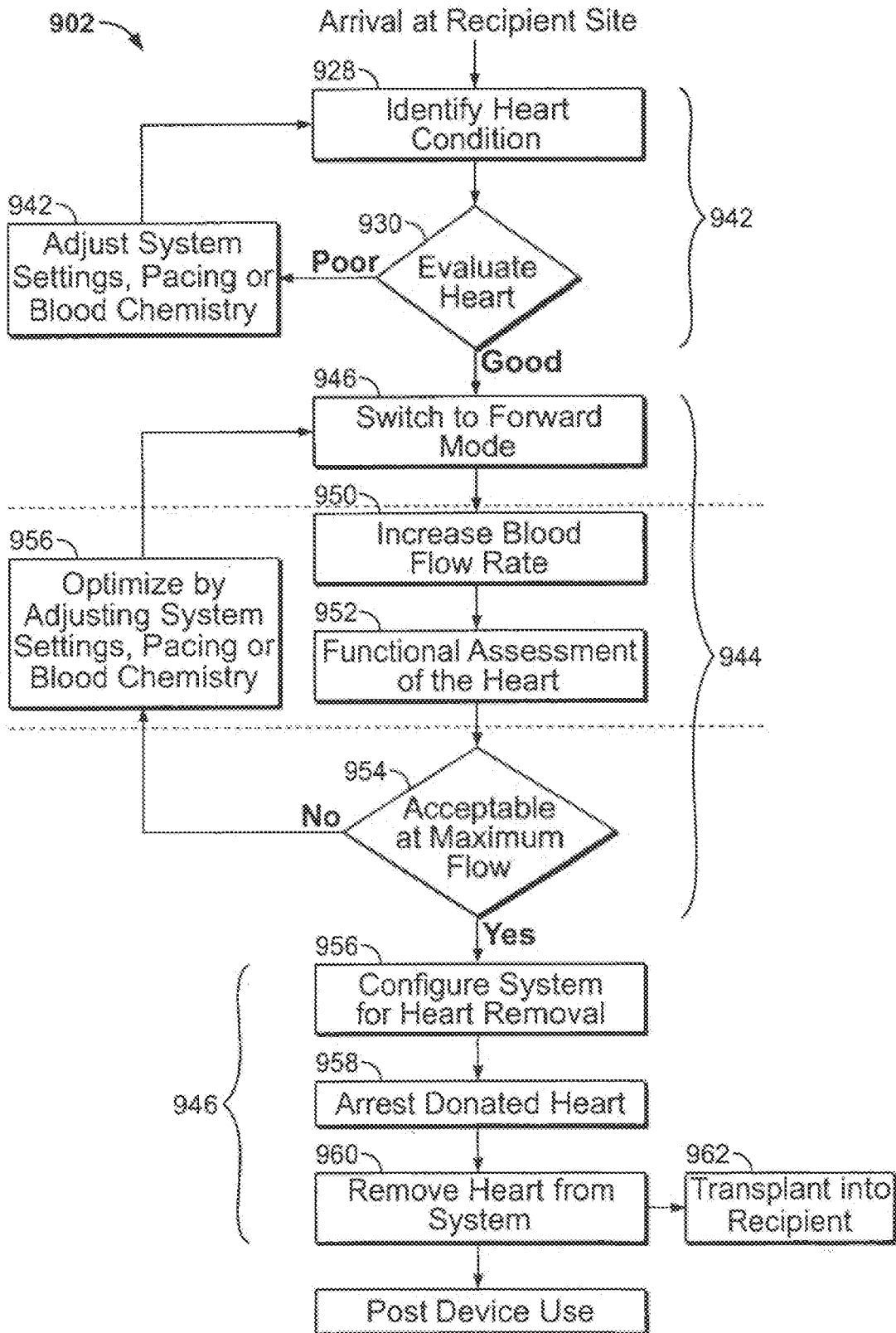

FIG. 30

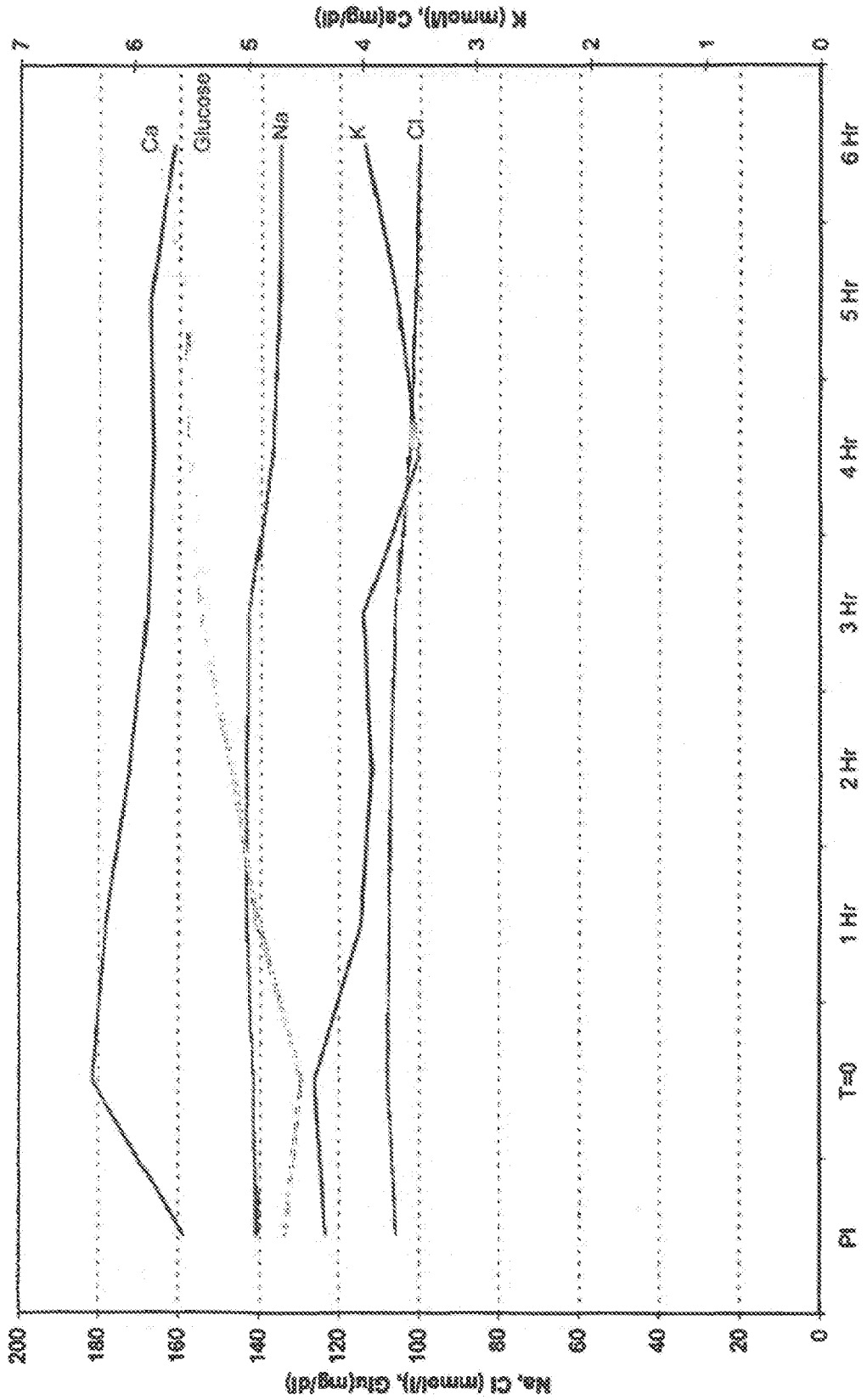

Fig. 31

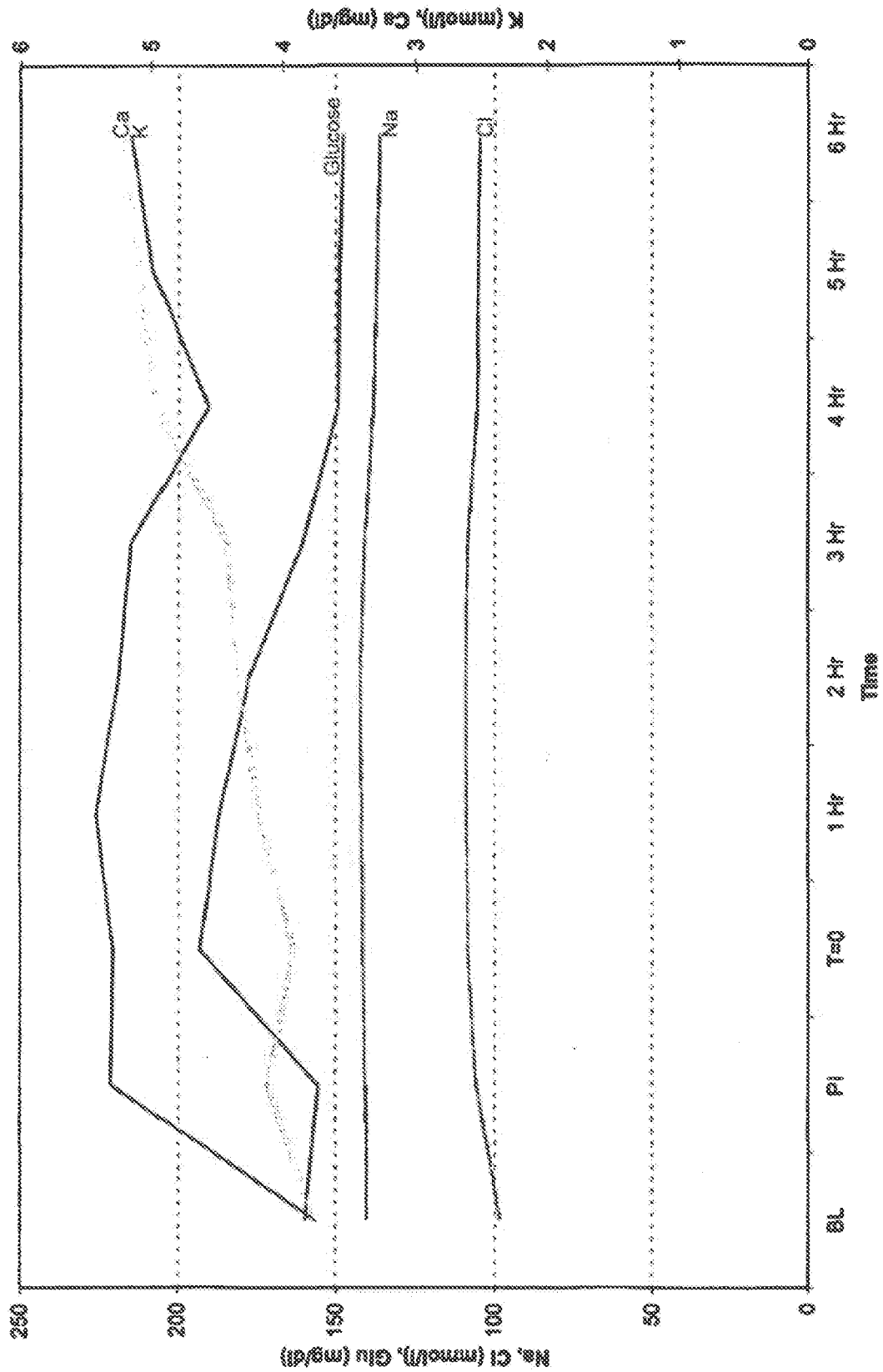

Fig. 32

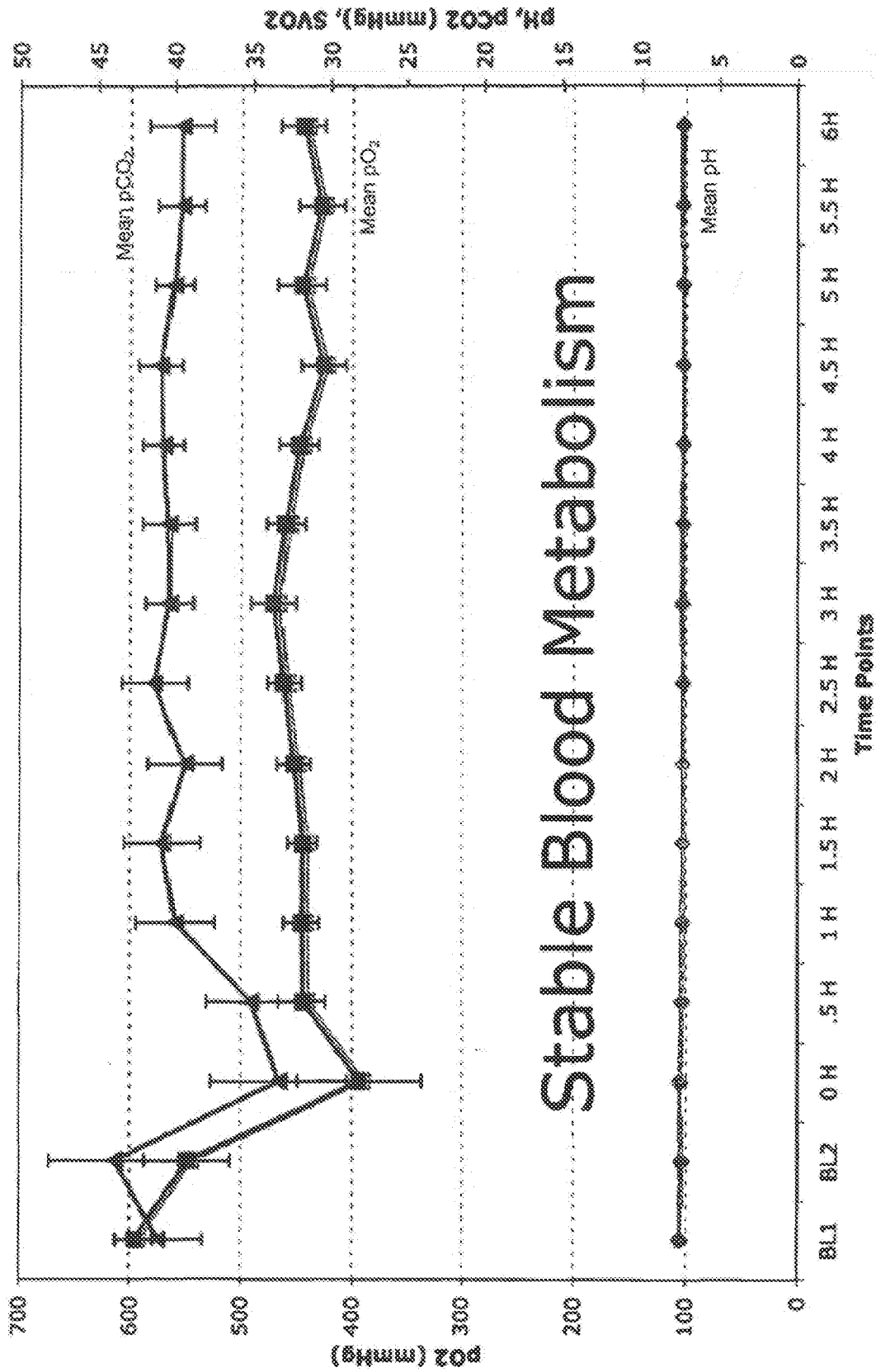

Fig. 33

SYSTEMS AND METHODS FOR EX-VIVO ORGAN CARE

REFERENCE TO RELATED APPLICATIONS

[0001] This application claims the benefit of U.S. Provisional Patent Application Ser. No. 60/616,835, filed on Oct. 7, 2004; U.S. Provisional Patent Application Ser. No. 60/694,971, filed on Jun. 28, 2005; and U.S. Provisional patent application filed on Oct. 6, 2005, and entitled Systems and Methods for Ex-Vivo Organ Care. The specifications of each of the foregoing are incorporated by reference herein in their entirety.

FIELD OF THE INVENTION

[0002] The invention generally relates to systems, methods, and devices for ex-vivo organ care. More particularly, in various embodiments, the invention relates to caring for an organ ex-vivo at physiologic or near-physiologic conditions.

BACKGROUND OF THE INVENTION

[0003] Current organ preservation techniques typically involve hypothermic storage of the organ in a chemical perfusate solution on ice. In the case of a heart, it is typically arrested, and cooled with the storage/cardioplegic solution in a hypothermic, non-functioning state. These techniques utilize a variety of cardioplegic solutions, none of which sufficiently protect the heart from myocardial damage resulting from ischemia. Such injuries are particularly undesirable when an organ, such as a heart, is intended to be transplanted from a donor into a recipient. In addition to myocardial damage resulting from ischemia, reperfusion of a heart may exacerbate the myocardial injury and may cause coronary vascular endothelial and smooth muscle injury, which may lead to coronary vasomotor dysfunction.

[0004] Using conventional approaches, such injuries increase as a function of the length of time an organ is maintained ex-vivo. For example, in the case of a heart, typically it may be maintained ex-vivo for only a few hours before it becomes unusable for transplantation. This relatively brief time period limits the number of recipients who can be reached from a given donor site, thereby restricting the recipient pool for a harvested heart. Even within the few hour time limit, the heart may nevertheless be significantly damaged. A significant issue is that there may not be any apparent indication of the damage. Because of this, less-than-optimal organs may be transplanted, resulting in post-transplant organ dysfunction or other injuries. Thus, it would be desirable to develop techniques that can extend the time during which an organ can be preserved in a healthy state ex-vivo. Such techniques would reduce the risk of transplantation failure and enlarge potential donor and recipient pools.

[0005] Effective preservation of an ex-vivo organ would also provide numerous other benefits. For instance, prolonged ex-vivo preservation would permit more careful monitoring and functional testing of the harvested organ. This would in turn allow earlier detection and potential repair of defects in the harvested organ, further reducing the likelihood of transplantation failure. The ability to perform simple repairs on the organ would also allow many organs with minor defects to be saved, whereas current transplantation techniques require them to be discarded.

[0006] In addition, more effective matching between the organ and a particular recipient may be achieved, further reducing the likelihood of eventual organ rejection. Current transplantation techniques rely mainly on matching donor and recipient blood types, which by itself is a relatively unreliable indicator of whether or not the organ will be rejected by the recipient. A more preferred test for organ compatibility is a Human Leukocyte Antigen (HLA) matching test, but current cold ischemic organ preservation approaches preclude the use of this test, which can often require 12 hours or more to complete.

[0007] Prolonged and reliable ex-vivo organ care would also provide benefits outside the context of organ transplantation. For example, a patient's body, as a whole, can typically tolerate much lower levels of chemo-, bio- and radiation therapy than many particular organs. An ex-vivo organ care system would permit an organ to be removed from the body and treated in isolation, reducing the risk of damage to other parts of the body.

[0008] In view of the foregoing, improved systems, methods, and devices for caring for an organ ex-vivo are needed.

SUMMARY OF THE INVENTION

[0009] The invention addresses the deficiencies in the prior art by, in various embodiments, providing improved systems, methods and devices relating to portable ex-vivo organ care. More particularly, according to various aspects, the invention provides systems, methods and devices relating to portable ex-vivo heart care. According to one advancement, the heart care system of the invention maintains the heart in a beating state at, or near, normal physiological conditions. To this end, the system circulates an oxygenated, nutrient enriched perfusion fluid to the heart at or near physiological temperature, pressure and flow rate. According to one implementation, the system employs a blood product-based perfusion fluid to more accurately mimic normal physiologic conditions. In alternative embodiments, the system uses a synthetic blood substitute solution, while in other embodiments, the solution may contain a blood product in combination with a blood substitute product.

[0010] According to another advancement, the system of the invention can maintain a harvested heart in two modes of operation; a normal aortic flow mode (also referred to as "normal flow mode"), and a retrograde aortic flow mode (also referred to as a "retrograde flow mode"). Generally, in the normal flow mode, the system circulates the perfusion fluid to the heart in the same manner as blood would circulate in the human body. More particularly, the perfusion fluid enters the heart via the left atrium and is flowed away from the heart via the right and left ventricles. In normal flow mode, the system pumps the perfusion fluid to the heart at a rate of between about 1 liter/min and about 5 liters/minute. This mode is useful, for example, for performing functional testing to verify that the heart is defect free, both prior and subsequent to transportation to a donor location. Alternatively, in retrograde flow mode, the system flows the perfusion fluid into the heart via the aorta, through the coronary sinus, and then out of the heart via the right ventricle. In this mode of operation, the system reduces the flow rate of the perfusion fluid to between about 300 milliliters/min and about 1 liter/min. The inventors have found that the retrograde flow path, along with the reduced flow rate, reduces damage to the heart during extended

periods of ex-vivo care. Thus, according to one feature of the invention, the heart is transported to a donor site in retrograde flow mode.

[0011] According to various aspects, the systems and/or devices of the invention include, and/or the methods of the invention employ, one or more of: an organ chamber assembly for containing a heart during ex-vivo care; a reservoir for containing and optionally, defoaming and/or filtering a volume of perfusion fluid; a perfusion fluid pump for pumping/circulating perfusion fluid to and from the harvested heart; a heater assembly for maintaining the temperature of the perfusion fluid at or near physiological temperatures; a flow mode selector valve for switching between normal and retrograde flow modes; an oxygenator for re-oxygenating the perfusion fluid subsequent to it being expelled by the heart; a nutritional subsystem for replenishing nutrients in the perfusion fluid as they are metabolized by the heart and for providing preservatives to the perfusion fluid to reduce, for example, ischemia and/or other reperfusion related injuries to the heart; a sensor subsystem for monitoring, for example, temperature, pressure, flow rate and/or oxygenation of the perfusion fluid, and/or electrical signals from the heart and/or the various components employed to maintain suitable flow conditions to and from the heart; an operator interface for assisting an operator in monitoring system operation and/or the condition of the heart, and/or for enabling the operator to set various operating parameters; a power subsystem for providing fault tolerant power to the organ care system; and a control subsystem for controlling operation of the organ care system.

[0012] Operationally, in one practice, a heart is harvested from a donor and affixed to the organ chamber assembly by a process of cannulation. The perfusion fluid pump pumps perfusion fluid from a reservoir to the heater assembly. The heater assembly heats the perfusion fluid to or near a normal physiological temperature. According to one embodiment, the heater assembly heats the perfusion fluid to between about 32° C. and about 37° C. From the heater assembly, the perfusion fluid flows to the flow mode selector valve. Initially, the flow mode selector valve is positioned for retrograde flow mode to direct the perfusion fluid from the heater assembly to a first interface on the organ chamber assembly. Also referred to as an aorta interface or the left ventricle interface, the first interface is cannulated to vascular tissue of the left ventricle (e.g., an aorta stub) via a conduit located within the organ chamber assembly. The heart then pumps the perfusion fluid out of the heart through the right ventricle via a second interface on the organ chamber assembly. The second interface, also referred to as a pulmonary artery interface or right ventricle interface, is cannulated to vascular tissue of the right ventricle (e.g., a pulmonary artery stub) via a conduit located within the organ chamber assembly. In retrograde flow mode, fluid is not pumped into or out of the left side of the heart other than in the form of a small trickle of perfusion fluid, which is delivered to moisten the left atrium. In response to the flow mode selector valve being in the normal flow mode position, it directs the perfusion fluid into the left atrium of the heart via a third interface on the organ chamber assembly. The third interface, also referred to as a pulmonary vein interface or left atrium interface, is cannulated to the vascular tissue of the left atrium (e.g., a pulmonary vein stub) via a conduit located within the organ chamber assembly. The heart then

expels the perfusion fluid through the left ventricle via the aorta interface, and through the right ventricle via the pulmonary artery interface.

[0013] In both modes of operation, from the pulmonary artery interface, the perfusion fluid flows into the oxygenator. The oxygenator receives oxygen from an external or onboard gas source and applies gas (e.g., oxygen) to the perfusion fluid prior to returning it to the reservoir. The system may include one or more oxygen saturation sensors to measure the oxygen saturation level of the perfusion fluid to ensure that the perfusion fluid is maintained at physiological oxygen levels. In the embodiments where the perfusion fluid is blood-product based, it contains red blood cells (i.e., oxygen carrying cells). Optionally, the oxygen sensors also provide a hematocrit measurement of the concentration of red blood cells in the perfusion fluid.

[0014] In both normal and retrograde flow modes, the nutritional subsystem infuses the perfusion fluid with a supply of maintenance solutions as the perfusion fluid flows through the system, and in some embodiments, while it is in the reservoir. According to one feature, the maintenance solutions include nutrients, such as glucose. According to another feature, the maintenance solutions include a supply of therapeutics and/or preservatives (e.g., cardio stimulants, insulin, amino acids, etc.) for reducing ischemia and/or other reperfusion related injuries to the heart.

[0015] According to another practice, the perfusion fluid includes blood removed from the donor through a process of exsanguination during harvesting of the heart. Initially, the blood from the donor is loaded into the reservoir and the cannulation locations in the organ chamber assembly are bypassed with a bypass conduit to enable normal mode flow of perfusion fluid through the system without a heart being present. Prior to cannulating the harvested heart, the system may be primed by circulating the exsanguinated donor blood through the system to heat, oxygenate and/or filter it. Nutrients, preservatives, and/or other therapeutics may also be provided during priming via the infusion pump of the nutritional subsystem. During priming, various parameters may also be initialized and calibrated via the operator interface during priming. Once primed and running appropriately, the pump flow is reduced or cycled off, the bypass conduit is removed from the organ chamber assembly, and the heart is cannulated into the organ chamber assembly. The pump flow is then restored or increased; as the case may be. According to one feature, the operator interface may be plugged into the system via a hard wired connection, or may be unplugged and used to wirelessly communicate with the system of the invention.

[0016] According to one feature, the system includes a plurality of compliance chambers. The compliance chambers are essentially small inline fluid accumulators with flexible, resilient walls for simulating the human body's vascular compliance by aiding the system in more accurately mimicking blood flow in the human body, for example, by providing flow back-pressure and/or by filtering/reducing fluid pressure spikes due, for example, to flow rate changes. In one configuration, compliance chambers are located on either side of the flow mode selector valve and on the output of the perfusion fluid pump. According to one feature, a compliance chamber is located next to a clamp used for regulating back pressure seen by the aorta during normal flow mode operation.

[0017] According to one implementation, the sensor subsystem includes an electrocardiogram (ECG) sensor for monitoring electrical signals from the heart. According to one embodiment, the control subsystem synchronizes the pumping of the perfusion fluid to the heart with the ECG signals. According to one feature, the ECG signals include an r-wave, and the control subsystem uses the r-wave to synchronize the fluid pumping with a diastolic state of the heart. According to another feature, the control subsystem adjusts pump stroke volume and/or pump rate in dependence on the ECG signals. For example, in one embodiment, the control subsystem reduces the pump stroke volume as heart rate increases in order to maintain blood flow. In another embodiment, the system reduces the pump stroke volume in response to detecting an irregular heart rate. In both cases, the result is to reduce fluid volume pumped to the heart, which in turn reduces the likelihood of causing damage to the heart. In various embodiments, the sensors include perfusion fluid flow rate and/or flow pressure sensors, which provide feedback for controlling the perfusion fluid pump. According to one embodiment, to more accurately simulate normal circulation through the body, the pump of the system is a pulsatile pump.

[0018] According to one aspect of the invention, the organ chamber assembly includes a plurality of improved features. More particularly, in one configuration, the organ chamber assembly of the invention includes a housing, an outer lid and an intermediate lid. The housing includes a bottom and one or more walls for containing the organ. The intermediate lid covers an opening to the housing for substantially enclosing the organ within the housing, and includes a frame and a flexible membrane suspended within the frame. The flexible membrane, preferably, is transparent but may be opaque, translucent, or substantially transparent. According to one feature, the flexible membrane includes sufficient excess membrane material to contact an organ contained within the chamber. This feature enables a medical operator to touch/examine the organ indirectly through the membrane while still maintaining sterility of the system and the organ. The outer lid opens and closes over the intermediate lid independently from the intermediate lid. Preferably, the outer lid is rigid enough to protect the organ from physical contact, indirect or direct.

[0019] According to one implementation, the intermediate lid is hinged to the housing. The intermediate lid may also include a latch for securing the intermediate lid closed over the opening of the organ chamber. The outer lid may be similarly hinged and latched. In some configurations, gaskets are provided for forming a fluid seal between the intermediate lid frame and the one or more organ chamber walls, and/or for forming a fluid seal between the periphery of the outer lid and the frame of the intermediate lid.

[0020] Optionally, the organ chamber assembly includes a pad or a sac assembly sized and shaped for interfitting within a bottom of the housing. Preferably, the pad assembly includes a pad formed from a material resilient enough to cushion the organ from mechanical vibrations and shocks during transport. In the case of the organ chamber assembly being configured to receive a heart, according to one feature, the pad of the invention includes a mechanism for receiving at least one electrode. The mechanism may include, without limitation, one or more slots, indentations, protrusions, through apertures, partially through apertures, hooks, eyelets, snaps, adhesive patches, or the like. According to one

advantage, the mechanism allows for adjustable placement of the at least one electrode on or in the pad to accommodate differently sized and shaped hearts. According to one embodiment, the pad includes a through-aperture through which an electrical lead of the at least one electrode may pass.

[0021] According to one embodiment, the pad assembly includes at least one electrode adjustably positioned at a location on or in the pad in such a way as to facilitate contact with a heart placed on the pad in the organ chamber assembly. According to one configuration, the at least one electrode rests on the surface of the pad and is held in place by the weight of the heart. In another configuration, the at least one electrode is glued to the surface of the pad. The at least one electrode includes one or more sensors for monitoring one or more electrical signals from the heart. It may also include one or more defibrillator contacts for providing an electrical signal to the heart. One advantage of the pad/electrode configuration of the invention is that it does not require the at least one electrode to be permanently or temporarily sutured or otherwise mechanically connected to the heart. Instead, electrical connection is made by placing the heart on the one or more electrodes. In one configuration, the at least one electrode includes an integrated sensor and defibrillation contact that allows the user to monitor electrical signals from the heart and provide an electrical signal to the heart through a common electrical interface connection to the organ chamber assembly. According to another feature, the common electrical interface includes one or more electrical ports on the organ chamber assembly for transferring electrical signals between the at least one electrode within the chamber and instrumentation located external to the housing. By way of example, the ports may provide the ECG signals to an external processor and/or display, and/or may provide defibrillation power to the electrodes.

[0022] Optionally, the organ chamber housing also includes a base for angling the housing for optimal heart function. According to one feature, the base maintains a heart contained within the organ chamber at an angle of between about 30° and about 60° relative to horizontal.

[0023] According to another aspect, the perfusion fluid heater assembly of the invention includes a plurality of improved features relating to providing a compact, solid state mechanism for heating the perfusion fluid. Some features of the heater assembly make it particularly suitable for heating blood-product based embodiments of the perfusion fluid. In one embodiment, the heater assembly of the invention includes an inlet, an outlet, a flow channel, first and second flow channel plates and a first heater. The flow channel is formed between the first and second flow channel plates. The inlet flows the perfusion fluid into the flow channel and the outlet flows the perfusion fluid out of the heater. The first and second flow channel plates have substantially bioinert perfusion fluid contacting surfaces for providing direct contact with the perfusion fluid flowing through the channel. The perfusion fluid contacting surfaces may be formed, for example, from a treatment or coating on a substrate or may be the substrate surface itself. The first heater is thermally coupled to the first flow channel plate for heating the first flow channel plate. In one configuration, the first heater is located on a nonperfusion fluid contacting side of the first flow channel plate. According to a further embodiment, the heater assembly of the invention also

includes a second heater thermally coupled to the second flow channel plate for heating the second flow channel plate to provide a more uniform temperature distribution in the flow channel.

[0024] According to one configuration, the heater assembly includes a first heater plate disposed between the first heater and the first flow channel plate for thermally coupling heat from the first heater to the first flow channel plate. According to one feature, the first heater plate is formed from a material, such as aluminum, that conducts and distributes heat from the heater relatively uniformly. The uniformly distributed heat of the heater plate is then coupled to the first channel plate, which preferably is formed from a bioinert material, such as titanium, which does not necessarily provide sufficiently uniform heat distribution if put in direct contact with the heater. The heater assembly may also include a second heater plate disposed between the second heater and the second flow channel plate for coupling heat from the second heater to the second flow channel plate.

[0025] According to one embodiment, the first and/or second heaters of the invention are resistive heaters. In one configuration, they each include a resistive heating element formed on a polyimide substrate. According to a further configuration, the resistive heating elements have a resistance of about 5 ohms. In other configurations, the resistance of the heating elements ranges from about 3 ohms to about 10 ohms.

[0026] Optionally, the heater assembly of the invention includes one or more temperature sensors. For example, the heater assembly may include a temperature sensor at its outlet for reporting the temperature of the perfusion fluid exiting the heater to the control subsystem. The signal from this sensor may be employed in a feedback loop to control drive signals to the first and second heaters to control the temperature of the heater plates. Additionally, to ensure that the perfusion fluid contacting surfaces of the heater plates do not reach a temperature that might damage the perfusion fluid, the heater assembly may also include temperature sensors for reporting the temperature of the first and/or second heaters to the control subsystem. The signals from these sensors may also be employed in a feedback loop to further control the drive signals to the first and/or second heaters to limit the maximum temperature of the heater plates. According to a variation of this embodiment, the heater assembly may include temperature sensors for reporting the temperature of the first and/or second heaters to the control subsystem.

[0027] To provide improved contact between the first and/or second heaters and their respective heater plates, and also between the first and/or second heater plates and their respective flow channel plates, the heater assembly may also include first and second resilient pads disposed on the respective heaters for maintaining the first heater in contact with the first heater plate and the second heater in contact with the second heater plate in response to compressive force. The compressive force may be provided, for example, by way of one or more heater assembly housing components. According to one feature, the heater assembly includes housing components formed from a polycarbonate, and weighs less than about 5 lb, while in other embodiments the heater assembly may weigh less than about 4 lb, less than about 3 lb, less than about 2 lb, or even less than about 1 lb. According to another feature, the heater assembly is about 6.75 inches long, about 2.75 inches wide, and about 2.5

inches thick, all exclusive of inlet and outlet ports and temperature sensor assemblies. According to another feature, the heater assembly is a single use disposable assembly.

[0028] According to one embodiment, in operation, the heater assembly uses between about 1 Watt and about 200 Watts of power. According to a further embodiment, the heater assembly of the invention is sized and shaped to transition about 2.5 liters of perfusion fluid flowing through the channel at a rate of between about 300 ml/min and about 5 L/min from a temperature of less than about 30° C. to a temperature of about 37° C. in less than about 25 minutes, less than about 20 minutes, less than about 15 minutes or even less than about 10 minutes, without causing substantial hemolysis to the blood cells or denaturation of any proteins that may be contained in the perfusion fluid.

[0029] According to a further embodiment, the power subsystem of the invention provides a fault tolerant battery arrangement. More particularly, a plurality of batteries are interlocked such that all of them may not be removed from the system at any particular time while the system is operating to maintain an organ. According to one feature, the power subsystem can switch between external power and onboard battery backup, without interruption of system operation. According to another feature, the power subsystem automatically allocates externally supplied power between powering the system, charging the batteries, and charging internal batteries of the wireless operator interface.

[0030] According to another aspect, the invention segments various subsystems and components of the portable organ care system into two modules; a portable multiple use module and a single use disposable module. According to one segmentation, the system of the invention generally assigns perfusion fluid contacting (and thus, blood product contacting in embodiments employing a blood product perfusion fluid) components to the disposable module, and non perfusion-fluid-contacting (and thus, non-blood product contacting components) to the multiple use module. However, the disposable unit may also include non-blood contacting components. According to one feature, the perfusion-fluid contacting components may be coated or bonded with heparin or other anticoagulant or biocompatible material to reduce the inflammatory response that may otherwise arise when the perfusion fluid contacts the surfaces of the components. Heparin may also be added to the maintenance solutions for circulation within the system.

[0031] In one embodiment, the portable multiple use module includes a portable housing constructed on a portable chassis, and the single use disposable module includes a disposable chassis. To reduce weight, in one configuration, the single use module chassis is formed from molded plastic such as polycarbonate, and the multiple use module chassis is formed from molded materials such as polycarbonate or carbon fiber composites. According to one feature, the single use chassis unloaded with components weighs less than about 12 pounds and the loaded single use module weighs less than about 18 pounds. According to another feature, the multiple use housing and chassis unloaded with components weighs less than about 50 pounds, and when loaded with a multiple use module, batteries, gas, maintenance solutions, perfusion fluid and a heart, weighs about 85 pounds or less. According to another advantage, the system of the invention including both single and multiple use modules, exclusive of any perfusion, nutrient, preservative or other fluids, batteries and oxygen supply, weighs less than about 65 pounds.

[0032] The single use disposable chassis is sized and shaped for interlocking with the portable chassis of the multiple use module for electrical, mechanical, gas and fluid interoperation with the multiple use module. According to one feature, the multiple and single use modules communicate with each other via an optical interface, which comes into optical alignment automatically upon the single use disposable module being installed into the portable multiple use module. According to another feature, the portable multiple use module provides power to the single use disposable module via spring loaded connections, which also automatically connect upon the single use disposable module being installed into the portable multiple use module. According to one feature, the optical interface and spring loaded connections ensure that connection between the single and multiple modules is not lost due to jostling, for example, during transport over rough terrain.

[0033] In various embodiments, the organ chamber assembly and the pump interface assembly both mount to the disposable chassis. The pump interface assembly is aligned to receive a pumping force from the pump driver of the perfusion fluid pump, and the interface assembly then translates the pumping force to the perfusion fluid to circulate the perfusion fluid to the organ chamber assembly. According to one embodiment, the perfusion fluid pump is a pulsatile pump and the pump interface assembly includes a housing, a first deformable membrane, a fluid inlet, and a fluid outlet. The housing of the pump interface assembly includes an interior side and an exterior side. The first deformable membrane mounts in fluid tight interconnection with the interior side of the housing to form a chamber between an interior side of the first deformable membrane and the interior side of the housing. The fluid inlet receives perfusion fluid, for example, from the reservoir, and provides the fluid into the chamber in response to the pump driver moving in a direction away from the interior side of the housing, and thus deforming the first deformable membrane in the same direction. The outlet expels the perfusion fluid out of the chamber, for example, to the heater assembly, in response to the pump driver moving in a direction toward the interior side of the housing.

[0034] According to one configuration, the pump interface assembly includes a bracket for fitting over a periphery of the first deformable membrane to form the fluid tight seal between the periphery of the interior side of the deformable membrane and a periphery of the interior side of the housing. According to a further configuration, the pump interface assembly includes a gasket for providing a fluid tight seal between the perfusion fluid pump driver and the pump interface housing.

[0035] According to one implementation, the system also includes a flow valve positioned on the input to the fluid inlet. The flow valve includes a ball valve assembly oriented to open and pass the perfusion fluid into the chamber through the bidirectional fluid inlet in response to the pump driver moving in the direction away from the interior side of the housing, and oriented to close and stop perfusion fluid passing back out of the chamber through the fluid inlet in response to the pump driver moving in the direction toward the interior surface of the housing. In a further implementation, the fluid outlet also includes a ball valve assembly oriented to close in response to the pump driver moving in the direction away from the interior surface of the housing, and to open to expel the organ perfusion fluid through the

fluid outlet in response to the pump driver moving in the direction toward the interior side of the housing.

[0036] Optionally, the perfusion fluid pump rigidly mounts to the portable multiple use chassis, the pump interface assembly rigidly mounts to the disposable single use chassis, and the system includes features for automatically forming a fluid tight seal between the perfusion pump driver and the pump interface assembly in response to the single use disposable module being interfitted with the portable multiple use module. More particularly, the pump interface assembly may include one or more projections out of the exterior side of the interface assembly housing, sized and shaped for engaging with and abutting one or more surfaces on the portable multiple-use module to force/draw the interior side of the pump interface assembly housing in a direction toward the pump driver of the perfusion pump.

[0037] According to one feature, the pump interface assembly includes a second deformable membrane mounted adjacent to the first deformable membrane for providing a fault tolerant seal in case the first deformable membrane tears. According to another feature, the pump interface assembly is formed at least in part from a polycarbonate or other molded plastic material, to reduce the weight of the single use disposable module.

[0038] In one embodiment, the perfusion fluid reservoir mounts to the single use disposable chassis and is in fluid communication with the organ chamber. According to a further embodiment, the flow mode selector valve mounts to the disposable chassis. In other embodiments, the solid state perfusion heater of the invention mounts to the disposable chassis. The oxygenator is preferably provided with the multiple-use module, but in certain embodiments may alternatively be part of the disposable module. The oxygen source feeding the oxygenator may be included on the multiple use portable chassis, may be part of the multiple-use module, or may be external to the system.

[0039] In one configuration, the various sensors associated with the heater assembly, the oxygenator and/or the perfusion fluid pump are included on the disposable single use module. However, this need not be the case, for example, with regard to non-perfusion fluid contacting sensors. According to one embodiment, the single use disposable module employs an oxygen sensor including in-line cuvette through which the perfusion fluid passes, an optical source for directing light at the perfusion fluid passing through the cuvette, and an optical sensor for measuring an optical quality of the perfusion fluid passing through the cuvette. Preferably, the in-line cuvette seamlessly or substantially seamlessly attaches to a perfusion fluid flow conduit to reduce turbulence in the perfusion fluid and provide one or more accurate measurements. The seamless or substantially seamless configuration also reduces damage to any blood based components of the perfusion fluid.

[0040] According to a further configuration, the disposable single-use module includes the above-mentioned plurality of inline compliance chambers located, for example, at the outlet of the perfusion fluid pump, and on either side of the mode select valve between the organ chamber and the mode select valve. In a further embodiment, the disposable single-use module includes a plurality of ports for sampling fluids from the organ chamber assembly. According to one feature, the ports are interlocked such that sampling fluid from a first of the plurality of ports prohibits simultaneously sampling fluids from a second port of the plurality. This

safety feature reduces the likelihood of mixing fluid samples and inadvertently opening the ports. In one embodiment, the organ chamber assembly includes ports for fluid interconnection with one or more of the pulmonary artery, aorta, and left atrium interfaces.

[0041] In another aspect, the invention is directed to a method of preserving a heart ex-vivo. The method includes placing a heart in a protective chamber of a portable organ care system, pumping a perfusion fluid to the heart, the perfusion fluid being at a temperature of between about 25° C. and about 37° C., and at a volume of between about 200 ml/min and about 5 L/min, monitoring one or more physiologic characteristics of the heart while it is beating in the protective chamber, and adjusting a pumping characteristic based at least in part on the electrical characteristics to preserve the heart ex vivo.

[0042] According to another aspect, the invention is directed to a method of preserving a heart ex vivo, the method including the steps of placing a heart on one or more electrodes in a protective chamber of a portable organ care system, pumping a perfusion fluid to the heart, the perfusion fluid being at a temperature of between about 25° C. and about 37° C., and at a volume of between about 200 ml/min and about 5 L/min, and monitoring electrical signals from the electrodes while pumping the perfusion fluid to the heart to preserve the heart ex vivo.

[0043] In a further aspect, the invention is directed to a method of transporting a heart ex vivo, including the steps of placing a heart for transplantation in a protective chamber of a portable organ care system, pumping a perfusion fluid into the heart via an aorta of the heart, providing a flow of the perfusion fluid away from the heart via a right ventricle of the heart, and transporting the heart in the portable organ care system from a donor site to a recipient site while pumping the perfusion fluid into the heart via the aorta and providing the flow of the perfusion fluid away from the heart via the right ventricle.

[0044] According to an additional aspect, the invention is directed to a method of evaluating a heart for transplantation, including the steps of placing a heart in a protective chamber of a portable organ care system, pumping a perfusion fluid into the heart via a left ventricle of the heart, providing a flow of the perfusion fluid away from the heart via a right ventricle of the heart, transporting the heart via the portable organ care system from a donor site to a recipient site while pumping the perfusion fluid into the heart via the left ventricle and providing the flow of the perfusion fluid away from the heart via the right ventricle; prior to transplanting the heart into a recipient, operating a flow control external to the protective chamber to alter a flow of the perfusion fluid such that the perfusion fluid is pumped into the heart via a left atrium of the heart and is flowed away from the heart via the right ventricle and the left ventricle of the heart; and performing an evaluation of the heart. In certain embodiments the evaluation includes performing an HLA test on the heart while the perfusion fluid is pumping.

[0045] In another aspect, the invention is directed to a method of providing therapy to a heart. The method includes placing a heart in a protective chamber of a portable organ care system, pumping a perfusion fluid into the heart via a left ventricle of the heart, providing a flow of the perfusion fluid away from the heart via a right ventricle of the heart, operating a flow control external to the protective chamber

to alter a flow of the perfusion fluid such that the perfusion fluid is pumped into the heart via a left atrium of the heart and is flowed away from the heart via the right ventricle and the left ventricle of the heart, and administering a therapeutic treatment to the heart. The treatments may include, for example, administering one or more of immunosuppressive treatment, chemotherapy, gene therapy and irradiation therapy to the heart.

[0046] According to another aspect, the invention is directed to a method of transplanting a heart. The method includes arresting a heart of a donor, explanting the heart from the donor, transferring the heart to an organ care system, and pumping a perfusion fluid to the heart in less than 30 minutes after explanting the heart from the donor (so as to reduce the heart's explantation cold ischemia time), the perfusion fluid being at a temperature of between about 32° C. and about 37° C. In certain embodiments the heart is brought to a temperature of between about 35° C. and about 37° C. in less than 10 minutes after transferring the heart to the organ care system.

[0047] These and other features and advantages of the invention are described in further detail below with regard to illustrative embodiments of the invention.

BRIEF DESCRIPTION OF THE DRAWINGS

[0048] The following figures depict illustrative embodiments of the invention in which like reference numerals refer to like elements. These depicted embodiments may not be drawn to scale and are to be understood as illustrative of the invention and not as limiting, the scope of the invention instead being defined by the appended claims.

[0049] FIG. 1 is a schematic diagram of a portable organ care system according to an illustrative embodiment of the invention.

[0050] FIG. 2 is a diagram depicting a harvested heart.

[0051] FIG. 3 is a conceptual diagram depicting the harvested heart of FIG. 2 interconnected with the organ care system of FIG. 1 in a normal flow mode configuration according to an illustrative embodiment of the invention.

[0052] FIG. 4 is a conceptual diagram depicting the harvested heart of FIG. 2 interconnected with the organ care system of FIG. 1 in a retrograde flow mode configuration according to an illustrative embodiment of the invention.

[0053] FIGS. 5A-5F show various views of an organ chamber assembly of the type employed in the organ care system of FIG. 1 according to an illustrative embodiment of the invention.

[0054] FIGS. 6A-6F show various views of a perfusion heater assembly of the type employed in the organ care system of FIG. 1 according to an illustrative embodiment of the invention.

[0055] FIG. 7 shows a more detailed view of an exemplary resistive heater element of the type employed in the heater assembly of FIGS. 6A-6F.

[0056] FIGS. 8A-8C show various views of a perfusion fluid pump interface assembly according to an illustrative embodiment of the invention.

[0057] FIG. 9 shows a perspective view of a pump driver side of a perfusion fluid pump assembly of the type depicted in FIG. 1, along with a bracket for mounting with the perfusion pump interface assembly.

[0058] FIG. 10 shows a side view of the perfusion fluid pump interface assembly of FIGS. 8A-8C mated with the pump driver side of the perfusion fluid pump assembly of FIG. 9.

[0059] FIG. 11 depicts a block diagram of an illustrative control scheme for controlling operation of the organ care system of FIG. 1.

[0060] FIG. 12 is a block diagram of an exemplary data acquisition subsystem of the type that may be employed with an the illustrative organ care system of FIG. 1.

[0061] FIG. 13 is a block diagram of an exemplary heating control subsystem of the type that may be employed for maintaining perfusion fluid temperature in the illustrative organ care system of FIG. 1.

[0062] FIG. 14 is a block diagram of an exemplary power management subsystem of the type that may be employed in the illustrative organ care system of FIG. 1.

[0063] FIG. 15 is a block diagram of an exemplary pumping control subsystem of the type that may be employed for controlling operation of a perfusion fluid pump assembly in the illustrative organ care system of FIG. 1.

[0064] FIG. 16 is a graph depicting an r-wave with which the pumping control subsystem of FIG. 15 synchronizes according to an illustrative embodiment of the invention.

[0065] FIG. 17A-17J depict exemplary display screens of the type that may be employed with an operator interface according to an illustrative embodiment of the invention.

[0066] FIGS. 18A and 18B show an exemplary implementation of the system of FIG. 1 according to an illustrative embodiment of the invention.

[0067] FIGS. 19A-19C show various views of the system of FIGS. 18A and 18B with its top off and front panel open according to an illustrative embodiment of the invention.

[0068] FIG. 20A is a front perspective view of the system of FIGS. 18A and 18B with the top removed, the front panel open and the single use disposable module removed according to an illustrative embodiment of the invention.

[0069] FIG. 20B is a side view of a slot formed in a basin of the multiple use module of FIG. 20A for engaging with a corresponding projection in the single use disposable module.

[0070] FIG. 21A shows a mounting bracket for receiving and locking into place the single use disposable module within the multiple use module of FIG. 20A.

[0071] FIGS. 21B and 21C show installation of the single use disposable module into the multiple use module using the mounting bracket of FIG. 21A according to an illustrative embodiment of the invention.

[0072] FIGS. 22A-22C show exemplary mechanisms for automatically making electro-optical interconnections between the single use disposable module and the multiple use module during the installation of FIGS. 21B and 21C.

[0073] FIGS. 23A-23C show various views of the system of FIGS. 18A and 18B with all of the external walls removed according to an illustrative embodiment of the invention.

[0074] FIG. 23D is a conceptual diagram showing interconnections between the circuit boards of FIGS. 23A-23C according to an illustrative embodiment of the invention.

[0075] FIGS. 24A-24E show various top perspective views of a single use disposable module according to an illustrative embodiment of the invention.

[0076] FIGS. 25A-25C show various bottom perspective views of the illustrative single use disposable module of FIGS. 24A-24D.

[0077] FIGS. 26A and 26B depict the operation of a flow mode selector valve according to an illustrative embodiment of the invention.

[0078] FIGS. 27A and 27B show various top views of the single use disposable module of FIGS. 19A-19C with the top off of illustrative organ chamber.

[0079] FIGS. 28A-28C show various views of an exemplary hematocrit and oxygen saturation sensor of the type employed in the illustrative single use disposable module of FIGS. 19A-19C.

[0080] FIG. 29A is a flow diagram depicting a donor-side process for removing an organ from a donor and placing it into the organ care system of FIG. 1 according to an illustrative embodiment of the invention.

[0081] FIG. 29B is a diagram depicting a harvested heart with suture and cannulation sites according to an illustrative embodiment of the invention.

[0082] FIG. 30 is a flow diagram depicting a recipient-side process for removing an organ from the organ care system of FIG. 1 and transplanting it into a recipient according to an illustrative embodiment of the invention.

[0083] FIG. 31 depicts a chart demonstrating electrolyte stability for an organ under going perfusion in forward mode according to an embodiment of the invention.

[0084] FIG. 32 depicts a chart demonstrating electrolyte stability for an organ under going perfusion in retrograde mode according to another embodiment of the invention.

[0085] FIG. 33 depicts a chart demonstrating the arterial blood gas profile for an organ under going perfusion according to an embodiment of the invention.

ILLUSTRATIVE DESCRIPTION

[0086] As described above in summary, the invention generally provides improved approaches to ex-vivo organ care. More particularly, in various embodiments, the invention is directed to improved systems, methods and devices relating to maintaining an organ in an ex-vivo portable environment. According to one improvement, the organ preservation system of the invention maintains a heart beating at or near normal physiological conditions. To this end, the system circulates an oxygenated, nutrient enriched perfusion fluid to the heart at near physiological temperature, pressure and flow rate. According to one implementation, the system employs a perfusion fluid solution that more accurately mimics normal physiologic conditions. In one embodiment, the perfusion fluid is blood-product based. In alternative embodiments, the solution is synthetic blood substitute based. In other embodiments the solution may contain a blood product in combination with a blood substitute product.

[0087] According to various illustrative embodiments, the improvements of the invention enable an organ, such as a heart, to be maintained ex-vivo for extended periods of time, for example, exceeding 3, 4, 5, 6, 8, 10, 12, 14, 16, 18, 20, 22, 24 or more hours. Such extended ex-vivo maintenance times expand the pool of potential recipients for donor organs, making geographical distance between donors and recipients less important. Extended ex-vivo maintenance times of the invention also provide the time needed for better genetic and HLA matching between donor organs and organ recipients, increasing the likelihood of a favorable outcome. The ability to maintain the organ in a near physiologic functioning condition also enables a clinician to evaluate the organ's function ex-vivo, further increasing the likelihood of

transplantation success. In some instances, the extended maintenance time enables medical operators to perform repairs on donor organs with minor defects. According to another advantage, the increased ex-vivo organ maintenance times of the invention enable an organ to be removed from a patient, treated in isolation ex-vivo, and then put back into the body of a patient. Such treatment may include, without limitation, surgical treatments, chemo-, bio-, gene and/or radiation therapies.

[0088] The illustrative systems, methods and devices of the invention are described below in the following order. First, the components of an illustrative organ care system 100 are described. Second, illustrative operation of the system 100 is discussed. Third, a subset of the components of the system 100 are described in further detail. Fourth, illustrative control systems and methods for the system 100 are discussed. Fifth, an illustrative user interface is described. Sixth, mechanical features of the system 100 are discussed in further detail with regard to an exemplary implementation. Seventh, exemplary methods for employing the system 100 during an organ harvest, transport, and transplantation procedure are described. Eighth, illustrative perfusion, nutritional and preservative solutions suitable for use with the system 100 are presented.

[0089] Turning to the illustrative embodiments, FIG. 1 depicts a schematic diagram of a portable organ care system 100 according to an illustrative embodiment of the invention. FIG. 2 shows a conceptual drawing of a heart 102, which may be preserved/maintained ex-vivo by the organ care system 100 of the invention. Referring to FIGS. 1 and 2, the illustrative system 100 includes an organ chamber assembly 104 for containing the heart 102 during ex-vivo maintenance, a reservoir 160 for holding, defoaming and filtering the perfusion fluid 108, portal 774 for loading perfusion fluid 108 into the reservoir 160 and a portal 762 for applying therapeutics to the fluid 108 contained in the reservoir 160, a perfusion fluid pump 106 for pumping/circulating perfusion fluid 108 to and from the harvested heart 102; a heater assembly 110 for maintaining the temperature of the perfusion fluid 108 at or near physiological temperatures; a flow mode selector valve 112 for switching between normal and retrograde aortic flow modes (also referred to as “normal flow mode” and “retrograde flow mode,” respectively); an oxygenator 114 for re-oxygenating the perfusion fluid 108 subsequent to it being expelled by the heart 102; a nutritional subsystem 115 for replenishing nutrients 116 in the perfusion fluid 108 as they are metabolized by the heart 102 and for providing additional preservatives 118 to the perfusion fluid to reduce, for example, ischemia and/or other reperfusion related injuries to the heart 102. The illustrative system 100 also includes a plurality of sensors, including without limitation: temperature sensors 120, 122 and 124; pressure sensors 126, 128, 130 and 132; perfusion flow rate sensors 134, 136 and 138; a perfusion fluid oxygenation sensor 140; and sensor electrodes 142 and 144, and defibrillation source 143. The system 100 further includes: various components employed for maintaining suitable flow conditions to and from the heart 102; an operator interface 146 for assisting an operator in monitoring operation of the system 100, and the condition of the heart 102, and for enabling the operator to select various operating parameters; a power subsystem 148 for

providing fault tolerant power to the system 100; and a controller 150 for controlling operation of the organ care system 100.

[0090] Referring also to FIGS. 3 and 4, according to the illustrative embodiment, the system 100 can maintain the heart 102 in two modes of operation—a normal flow mode, shown in FIG. 3, and a retrograde flow mode shown in FIG. 4. Generally, in the normal flow mode of FIG. 3, the system 100 circulates the perfusion fluid 108 to the heart 102 in the same manner as blood would circulate in the human body. More particularly, referring to FIGS. 1-3, the perfusion fluid enters the left atrium 152 of the heart 102 via the pulmonary vein 168. The perfusion fluid 108 is flowed away from the right ventricle 154 via the pulmonary artery 164 and away from the left 156 ventricle via the aorta 158. In normal flow mode, the system 100 pumps the perfusion fluid to the heart 102 at a near physiological rate of between about 1 liter/min and about 5 liters/minute. This mode is useful, for example, for performing functional testing to verify that the heart 102 is defect free, both prior and subsequent to transportation to a donor location.

[0091] Alternatively, in retrograde flow mode, shown in FIG. 4, the system 100 flows the perfusion fluid 108 into the heart 102 via the aorta 158, through the coronary sinus 155 and other coronary vasculature of the heart, and out of the right ventricle 154 of the heart 102 via the pulmonary artery 164. As discussed in further detail below with regard to FIGS. 24A and 24B, the system 100 also provides a trickle flow 769 to the left atrium 152 through trickle valve 768. The trickle flow is provided in an amount sufficient to moisten the left atrium 152 and left ventricle 156. In certain applications the trickle flow is less than about 5 ml/min, less than about 1 ml/min, or less than about 0.1 ml/min. In this mode of operation, the system 100 reduces the flow rate of the perfusion fluid 108 to between about 300 milliliters/minute and about 1 liter/minute. The inventors have found that the retrograde flow path of FIG. 4, along with the reduced flow rate, reduces damage to the heart 102 during extended periods of ex-vivo maintenance. Thus, according to one feature of the invention, the heart 102 is transported to a donor site in retrograde flow mode.

[0092] Having briefly described the normal and retrograde flow modes, the system 100 will next be described in further detail operationally. Referring once again to FIGS. 1-4, in one practice, the heart 102 is harvested from a donor and cannulated into the organ chamber assembly 104. The perfusion fluid 108 is prepared for use within system 100 by being loaded into the reservoir 160 via portal 774 and, optionally, being treated with therapeutics via portal 762. The pump 106 pumps the loaded perfusion fluid 108 from a reservoir 160 to the heater assembly 110. The heater assembly 110 heats the perfusion fluid 108 to or near a normal physiological temperature. According to one embodiment, the heater assembly 110 heats the perfusion fluid to between about 32° C. and about 37° C. The heater assembly 110 has an internal flow channel with a cross-sectional flow area that is approximately equal to the inside cross-sectional area of fluid conduits that carry the perfusion fluid 108 into and/or away from the heater assembly 110, so as to minimize disturbance of fluid flow. From the heater assembly 110, the perfusion fluid 108 flows to the flow mode selector valve 112.

[0093] Initially, the flow mode selector valve 112 is positioned in retrograde mode to direct the perfusion fluid 108

from the heater assembly **110** into the organ chamber assembly **104** via a first interface **162**. Also referred to as an aorta interface or left ventricle interface, the interface **162** includes cannulation to vascular tissue of the left ventricle via an aperture **228b** located on the organ chamber assembly **104** (as shown in FIGS. 5A-5B). As the heart **102** warms, it begins to beat which causes the heart **102** to pump the perfusion fluid **108** through the coronary vasculature **155** and out of the heart **102** through the right ventricle **154** via a second interface **166**. The second interface **166**, also referred to as a pulmonary artery interface or a right ventricle interface, includes cannulation to vascular tissue of the right ventricle via an aperture **228c** located on the organ chamber assembly **104** (as shown in FIGS. 5A-5B). As mentioned above, in retrograde flow mode, fluid is not actively pumped into or out of the left side of the heart, except for a relatively small trickle **769** of perfusion fluid, which is delivered to moisten the left atrium **152** and left ventricle **156**, as described below in reference to FIGS. 24A-24E.

[0094] In response to the flow mode selector valve **112** being placed in the normal mode position, it directs the perfusion fluid **108** into the left atrium **152** of the heart **102** via a third interface **170**. The third interface **170**, also referred to as a pulmonary vein interface or left atrium interface, includes cannulation to vascular tissue of the left atrium **152** via an aperture **228a** located on the organ chamber assembly **104** (as shown in FIGS. 5A-5B). The heart **102** then expels the perfusion fluid **108** through the left ventricle **156** via the aorta interface **162** and through the right ventricle **154** via the pulmonary artery interface **166**.

[0095] Each of the interfaces **162**, **166** and **170** may be cannulated to the heart **102** by pulling vascular tissue (e.g., an aorta stub) over the end of the interface, then tying or otherwise securing the tissue to the interface. The vascular tissue is preferably a short segment of a blood vessel (e.g., an aorta stub **158**) that remains connected to the heart **102** after the heart **102** is severed and explanted from the donor. For example, the aorta interface **162** is cannulated to a small segment of the severed aorta **158** which has been formed by severing the aorta **158** in a location downstream from the coronary sinus **155**. In certain applications, the short vessel segments may be about 5 to about 10 inches in length or longer. The segments may also be shorter than about 5 inches. The segments may be about 2 to about 4 inches in length, or about 1 to about 2 inches in length; in other applications the segments may be less than about ½ inch, or less than about ¼ inch.

[0096] Alternatively, the cannulation may occur by affixing the interface directly to the applicable atrium or ventricle, as may be preferred in applications where the heart **102** is prepared for explantation by severing an entire blood vessel without leaving any stub portion of the vessel connected to the heart **102**. For example, a left atrium **152** cannulation can be formed by inserting the interface **170** directly into the left atrium **152** and clamping the interface **170** in place, without the need to tie to any pulmonary vein **168** tissue.

[0097] With continued reference to FIG. 1, in both flow modes the perfusion fluid **108** flows from the pulmonary artery interface **166** into the oxygenator **114**. The oxygenator **114** receives gas from an external or onboard source **172** through a gas regulator **174** and a gas flow chamber **176**, which can be a pulse-width modulated solenoid valve that

controls gas flow, or any other gas control device that allows for precise control of gas flow rate. A gas pressure gauge **178** provides a visual indication of how full the gas supply **172** is. The transducer **132** provides similar information to the controller **150**. The controller **150** can regulate automatically the gas flow into the oxygenator **114** in dependence, for example, on the perfusion fluid oxygen content measured at the sensor **140**. According to various illustrative embodiments, the oxygenator **114** is a standard membrane oxygenator, such as the Liliput 2 manufactured by Dideco, a division of Sorin Biomedical, or the MINIMAX PLUS™ manufactured by Medtronic, Inc. In the illustrative embodiment, the gas includes an oxygen and carbon dioxide mixture. An exemplary composition of such a mixture contains about 85% O₂, about 1% CO₂, with the balance being N₂. Subsequent to re-oxygenation, the oxygenator **114** returns the perfusion fluid **108** to the reservoir **160**. According to the illustrative embodiment, the sensor **140** measures the amount of light absorbed or reflected by the perfusion fluid **108** when applied at a multi-wavelength to provide an optical-based measurement of oxygen saturation. Since the perfusion fluid **108** is blood product based in certain embodiments, it may contain red blood cells (i.e., oxygen carrying cells). Accordingly, the sensor **140** also provides a signal **145** indicative of a hematocrit measurement of the perfusion fluid **108**. In alternative embodiments the solution **108** is formed of a synthetic blood substitute, while in other embodiments, the solution **108** may contain a blood product in combination with a blood substitute product.

[0098] Also, in both flow modes, the nutritional subsystem **115**, including a supply of maintenance solutions **116/118** and an infusion pump **182**, infuses the perfusion fluid **108** with nutrients **116**, such as glucose, as the perfusion **108** solution flows through the system **100**, and in some embodiments, while it is in the reservoir **160**. The maintenance solutions **116/118** also include a supply of therapeutics and preservatives **118** for reducing ischemia and other reperfusion related injuries to the heart **102**.

[0099] Both normal and retrograde flow modes are described in further detail below with reference to FIGS. 24A-26B.

[0100] According to the illustrative embodiment, the system **100** is primed prior to introducing an organ into the organ chamber assembly **104**. During priming, a priming solution (described below) is inserted into the organ chamber **160** and pumped through the system **100**. In one exemplary application, the priming occurs for a period of between about 5 and about 20 minutes. The cannulation interfaces **162**, **166** and **170** in the organ chamber assembly **104** are bypassed to enable normal mode flow of perfusion fluid **108** through the system **100**, without the donor heart **102** being present. Blood (or a synthetic blood substitute) is then loaded into the reservoir **160**. The blood may be the blood exsanguinated from the donor during harvesting of the heart **102** or obtained from typed and cross-matched banked blood. The system **100** then circulates the blood (or blood substitute) through the system **100** to heat, oxygenate, and filter it. Nutrients, preservatives and/or other therapeutics are provided via the infusion pump **182** of the nutritional subsystem **115**. Various parameters may also be initialized and calibrated via the operator interface **146** during priming. Once the system **100** is running appropriately, the pump rate can be decreased or brought to zero, and the heart **102** can be cannulated into the organ chamber assembly **104**. The

pump rate can then be increased. Priming of the system 100 is described in further detail below with reference to the flow diagram of FIG. 29A.

[0101] As shown in FIG. 1, the system 100 also includes a plurality of compliance chambers 184, 186 and 188. The compliance chambers 184, 186 and 188 are essentially small inline fluid accumulators with flexible, resilient walls designed to simulate the human body's vascular compliance by aiding the system in more accurately mimicking blood flow in the human body, for example, by providing flow back-pressure and/or by filtering/reducing fluid pressure spikes due, for example, to flow rate changes and/or the pumping of the pump 106. According to the illustrative embodiment, the compliance chamber 184 is located between an output 112a of the mode valve 112 and the reservoir 160 and operates in combination with an adjustable clamp 190 during normal flow mode to provide back pressure to the aorta 158 to cause perfusion fluid to flow into the coronary sinus 155 to feed the heart 102. In the illustrative embodiment, the fluid back-pressure provided to the aorta 158 is between about 55 mmHg and about 85 mmHg, which is within an acceptable near-physiologic range of mean aortic blood pressure (which is typically between about 80 mmHg and about 100 mmHg). The back pressure to the aorta 158 aids the system 100 in simulating normal physiologic conditions. The compliance chamber 186 is located between an output 112b of the mode valve 112 and the pulmonary vein cannulation interface 170 of the organ chamber assembly 104. The primary function of the compliance chamber 186 is to provide back-pressure to the left atrium 152 and to smooth pressure/flow spikes caused from the pumping action of the perfusion fluid pump 106, which delivers blood to the heart without causing substantial fluid pressure spikes. In the illustrative embodiment, the fluid back-pressure provided to the left atrium 152 is between about 0 mmHg to about 14 mmHg, which is approximately the same as the left atrial pressure under normal physiologic conditions. The compliance chamber 188 is located between an output of a one way valve 310 and an inlet 110a of the heater 110. The primary function of the compliance chamber 188 is also to smooth pressure/flow spikes caused by the pumping action of the perfusion fluid pump 106 and to provide fluid back-pressure to the pulmonary artery 164. In the illustrative embodiment, the fluid back-pressure provided to the pulmonary artery 164 is between about 0 mmHg and about 25 mmHg, which is within an acceptable near-physiologic range of mean arterial blood pressure (between about 0 mmHg and about 12 mmHg).

[0102] The compliance chambers 184, 186 and 188 provide the benefits described above through their size and shape and the materials used in their design. The chambers 184, 186 and 188 are sized to contain about 20 ml to about 100 ml of fluid 108, and they are shaped in an oval configuration to allow them to receive fluid 108 and expand to dampen pressure spikes and to provide back-pressure to the heart 102. In certain applications, the material used for the chambers 184, 186 and 188 includes at least one flexible membrane, selected so that the chambers have a Shore A durometric hardness (ASTM D2240 00) of about 10 (more flexible) to about 60 (less flexible), with certain preferred embodiments having a hardness of between about 30 (+/-about 8) and about 50 (+/-about 8). In the illustrative embodiment, the compliance chamber 184 has a Shore A hardness of about 50 (+/-about 8) and the compliance

chamber 186 has a Shore A hardness of about 30 (+/-about 8). In the illustrative embodiment, the compliance chamber 188 has a dual-layered configuration, with an inner chamber having a Shore A hardness of about 50 (+/-about 8) and an outer sleeve having a Shore A hardness of about 30 (+/-about 8). Alternatively, the inner chamber can have a lower hardness (e.g., about 30, +/-about 8) and outer sleeve can have a higher hardness (e.g., about 50, +/-about 8).

[0103] Having provided an operational overview of the system 100, the organ chamber assembly 104, the perfusion heater assembly 110, and a pump head interface assembly 192 for interfacing with the pump 106 are next described in further detail. FIGS. 5A-5F depict various views of the illustrative organ chamber assembly 104 of FIG. 1. As shown most clearly in FIGS. 5A-5D, the organ chamber assembly 104 includes a housing 194, an outer lid 196 and an intermediate lid 198. The housing includes a bottom 194e and one or more walls 194a-194d for containing the heart 102. The intermediate lid 198 covers an opening 200 to the housing 194 for substantially enclosing the heart 102 within the housing 194. As most clearly shown in FIGS. 5E and 5F, the intermediate lid 198 includes a frame 198a and a flexible membrane 198b suspended within the frame 198a. The flexible membrane 198b, preferably, is transparent but may be opaque, translucent, or substantially transparent. According to one feature, the flexible membrane includes sufficient excess membrane material to contact the heart 102 when contained within the housing 195. This feature enables a medical operator to touch/examine the heart 102 indirectly through the membrane 198b, or apply an ultrasound probe to the heart 102 through the membrane 198b, while maintaining sterility of the housing 195. The membrane 198b may be made, for example, from any suitable flexible polymer plastic, for example polyurethane. The membrane 198b may also have integrated electrically conductive pads/contacts 199a and 199b through which electrical activity of the heart may be sensed via electrodes such as the electrodes 142 and 144, and/or for through which defibrillation or pacing signals may be delivered, as described more fully below. Alternatively, the contacts 199a and 199b may be electrodes including all or a portion of the functionality of the electrodes 142 and 144. As shown in FIG. 5C, the outer lid 196 opens and closes over the intermediate lid 198 independently from the intermediate lid 198. Preferably, the outer lid 196 is rigid enough to protect the heart 102 from physical contact, indirect or indirect. The outer lid 196 and the chamber 194 may also be made from any suitable polymer plastic, for example polycarbonate.

[0104] According to one implementation, the housing 194 includes two hinge sections 202a and 202b, and the intermediate lid frame 198a includes two corresponding mating hinge sections 204a and 204b, respectively. The hinge sections 202a and 202b on the housing 194 interfit with the hinge sections 204a and 204b on the intermediate lid frame 198a to enable the intermediate lid 198 to open and close relative to the opening 200 of the housing 194. As shown most clearly in FIGS. 5D and 5F, the organ chamber assembly 104 also includes two latches 206a and 206b for securing the intermediate lid 198 closed over the opening 200. As shown in FIGS. 5E and 5F, the latches 206a and 206b rotatably snap fit onto latch hinge section 208a and 208b, respectively, on the wall 194c of the housing 194. As shown most clearly in FIGS. 5A and 5E, the intermediate lid frame 198a also includes a hinge section 210. The hinge

section 210 rotatably snap fits with a mating hinge section 212 on the outer lid 196 to enable the outer lid 196 to open without opening the intermediate lid 198. As shown best in FIGS. 5B, 5D and 5F, the outer lid 196 also includes two cutouts 214a and 214b for enabling the latches 206a and 206b to clamp down on the edge 216 of the intermediate lid frame 198a. As shown in FIGS. 5B, 5D and 5F, the organ chamber assembly 104 also includes a latch 218, which rotatably snap fits onto a hinge part 220 on the wall 194c of the housing 194. In operation, the latch 218 engages a tab 221 on the edge 225 of the outer lid 196 to secure the outer lid 196 closed over the intermediate lid 198.

[0105] As shown most clearly in FIGS. 5E and 5F, the intermediate lid also includes two gaskets 198c and 198d. The gasket 198d interfits between a periphery of the intermediate lid frame 198a and a periphery of the outer lid 196 to form a fluid seal between the intermediate lid 198 and the outer lid 196 when the outer lid 196 is closed. The gasket 198c interfits between an outer rim 194f of the housing 194 and the intermediate lid frame 198a to form a fluid seal between the intermediate lid 198 and the periphery 194f of the housing 194 when the intermediate lid 198 is closed.

[0106] Optionally, the organ chamber assembly 104 includes a pad 222 or a sac assembly sized and shaped for interfitting over an inner bottom surface 194g of the housing 194. Preferably, the pad 222 is formed from a material resilient enough to cushion the heart 102 from mechanical vibrations and shocks during transport, for example a closed-cell foam. According to one feature, the pad 222 includes a mechanism for adjustably positioning a pair of electrodes, such as the electrodes 142 and 144 of FIG. 1. According to the illustrative embodiment, the mechanism includes two through-apertures 224a and 224b for passing electrical leads from the under side of the pad 222 to corresponding electrodes 142 and 144 on the heart-contacting surface of the pad. Passing the electrical leads through the pad 222 to the electrodes 142 and 144 enables the electrodes 142 and 144 to be adjustably positioned within the pad 222 to accommodate variously sized hearts. In other embodiments, the mechanism may include, without limitation, one or more differently oriented slots, indentations, protrusions, through apertures, partially through apertures, hooks, eyelets, adhesive patches, or the like. In certain embodiments, the pad 222 may be configured with one or more sleeve-like structures that allow an electrode to be inserted within the pad 222, thus providing a membrane-like surface of the pad 222 positioned between the electrode and the heart 102.

[0107] In some illustrative embodiments, the pad 222 is configured as a pad assembly, with the assembly including one or more electrodes, such as the electrodes 142 and 144, adjustably located in or on the pad 222. According to one advantage, the pad/electrode configuration of the invention facilitates contact between the electrodes and the heart 102 placed on the pad 222, without temporarily or permanently suturing or otherwise mechanically connecting the electrodes to the heart 102. The weight of the heart 102 itself can also help stabilize the electrodes during transport. According to the illustrative embodiment, the electrodes 142 and 144 include one or more sensors for monitoring one or more electrical signals from the heart and/or defibrillators for providing an electrical signal to the heart. As shown in FIGS. 1 and 5C, the organ chamber assembly 104 includes electrical interface connections 235a-235b, which mount into

the apertures 234a-234b, respectively, in the wall 194b of the housing 194. A cover 226 is provided for protecting the electrical interface connections 235a-235b when not being used.

[0108] As described below in further detail with reference to FIG. 15, the interface connections 235a and 235b couple electrical signals, such as ECG signals, from the electrodes 142 and 144 out of the housing 194, for example, to the controller 194 and/or the operator interface 146. As described in further detail below with reference to FIG. 22A, the interface connections 235a and 235b may also couple to a defibrillation source, which may be either provided by external instrumentation or through circuitry within the system 100, and which can send a defibrillation or pacing signal 143 through electrodes 142 and 144 to the heart 102.

[0109] As shown most clearly in FIGS. 5E and 5F, the organ chamber assembly 104 includes a resealable membrane interface 230, which mounts in an interface aperture 232. The interface 230 includes a frame 230a and a resealable polymer membrane 230b mounted in the frame 230a. The membrane 230b may be made of silicone or any other suitable polymer. In operation, the interface 230 is used to provide pacing leads, when necessary, to the heart 102, without having to open the chamber lids 196 and 198. The membrane 230b seals around the pacing leads to maintain a closed environment around the heart 102. The membrane 230b also reseals in response to removing the pacing leads.

[0110] As shown in FIGS. 5A and 5B, the organ chamber assembly 104 includes apertures 228a-228c for receiving the aorta interface 162, the pulmonary artery interface 166 and the pulmonary vein interface 170, described above with reference to FIGS. 1-4, and below with reference to FIGS. 24A-28C. As shown in FIG. 5D, the organ chamber assembly 104 also includes a drain 201 for draining perfusion fluid 108 out of the housing 194 back into the reservoir 160, and mounting receptacles 203A-203d for mounting the organ chamber assembly 104 onto the single use module (shown at 634 in FIG. 19A).

[0111] FIGS. 6A-6F depict various views of the perfusion fluid heater assembly 110 of FIG. 1. As shown in FIGS. 6A and 6B, the heater assembly 110 includes a housing 234 having an inlet 110a and an outlet 110b. As shown in both the longitudinal cross-sectional view of FIG. 6D and the lateral cross-sectional view of FIG. 6E, the heater assembly 110 includes a flow channel 240 extending between the inlet 110a and the outlet 110b. The heater assembly 110 may be conceptualized as having upper 236 and lower 238 symmetrical halves. Accordingly, only the upper half is shown in an exploded view in FIG. 6F.

[0112] Referring now to FIGS. 6D-6F, the flow channel 240 is formed between first 242 and second 244 flow channel plates. The inlet 110a flows the perfusion fluid into the flow channel 240 and the outlet 110b flows the perfusion fluid out of the heater 110. The first 242 and second 244 flow channel plates have substantially bioinert perfusion fluid 108 contacting surfaces (which may contain a blood-product in certain embodiments) for providing direct contact with the perfusion fluid flowing through the channel 240. The fluid contacting surfaces may be formed from a treatment or coating on the plate or may be the plate surface itself. The heater assembly 110 includes first and second electric heaters 246 and 248, respectively. The first heater 246 is located adjacent to and couples heat to a first heater plate 250. The first heater plate 250, in turn, couples the heat to the first flow

channel plate 242. Similarly, the second heater 248 is located adjacent to and couples heat to a second heater plate 252. The second heater plate 252 couples the heat to the second flow channel plate 244. According to the illustrative embodiment, the first 250 and second 252 heater plates are formed from a material, such as aluminum, that conducts and distributes heat from the first 246 and second 248 electric heaters, respectively, relatively uniformly. The uniform heat distribution of the heater plates 250 and 252 enables the flow channel plates to be formed from a bioinert material, such as titanium, reducing concern regarding its heat distribution characteristic.

[0113] Referring particularly to FIGS. 6E and 6F, the heater assembly 110 also includes O-rings 254 and 256 for fluid sealing respective flow channel plates 242 and 244 to the housing 234 to form the flow channel 240.

[0114] The heater assembly 110 further includes first assembly brackets 258 and 260. The assembly bracket 258 mounts on the top side 236 of the heater assembly 110 over a periphery of the electric heater 246 to sandwich the heater 246, the heater plate 250 and the flow channel plate 242 between the assembly bracket 258 and the housing 234. The bolts 262a-262j fit through corresponding through holes in the bracket 258, electric heater 246, heater plate 250 and flow channel plate 242, and thread into corresponding nuts 264a-264j to affix all of those components to the housing 234. The assembly bracket 260 mounts on the bottom side 238 of the heater assembly 110 in a similar fashion to affix the heater 248, the heater plate 252 and the flow channel plate 244 to the housing 234. A resilient pad 268 interfits within a periphery of the bracket 258. Similarly, a resilient pad 270 interfits within a periphery of the bracket 260. A bracket 272 fits over the pad 268. The bolts 278a-278f interfit through the holes 276a-276f, respectively, in the bracket 272 and thread into the nuts 280a-280f to compress the resilient pad 268 against the heater 246 to provide a more efficient heat transfer to the heater plate 250. The resilient pad 270 is compressed against the heater 248 in a similar fashion by the bracket 274.

[0115] As mentioned with respect to FIG. 1, and as also shown in FIG. 6A, the illustrative heater assembly 110 includes temperature sensors 120 and 122 and dual-sensor 124. The dual sensor 124 in practice includes a dual thermistor sensor for providing fault tolerance, measures the temperature of the perfusion fluid 108 exiting the heater assembly 110, and provides these temperatures to the controller 150. As described in further detail below with respect to the heating subsystem 149 of FIG. 13, the signals from the sensors 120, 122 and 124 may be employed in a feedback loop to control drive signals to the first 246 and/or second 248 heaters to control the temperature of the heaters 256 and 248. Additionally, to ensure that heater plates 250 and 252 and, therefore, the blood contacting surfaces 242 and 244 of the heater plates 250 and 252 do not reach a temperature that might damage the perfusion fluid, the illustrative heater assembly 110 also includes temperature sensors/lead wires 120 and 122 for monitoring the temperature of the heaters 246 and 248, respectively, and providing these temperatures to the controller 150. In practice, the sensors attached to sensors/lead wires 120 and 122 are RTD (resistance temperature device) based. As also discussed in further detail with respect to FIG. 13, the signals from the sensors attached to sensors/lead wires 120 and 122 may be employed in a feedback loop to further control the drive signals to the first

246 and/or second 248 heaters to limit the maximum temperature of the heater plates 250 and 252. As a fault protection, there are sensors for each of the heaters 246 and 248, so that if one should fail, the system can continue to operate with the temperature at the other sensor.

[0116] As described in further detail below with respect to FIG. 13, the heater 246 of the heater assembly 110 receives from the controller 150 drive signals 281a and 281b (collectively 281) onto corresponding drive lead 282a. Similarly, the heater 248 receives from the controller 150 drive signals 283a and 283b (collectively 283) onto drive lead 282b. The drive signals 281 and 283 control the current to, and thus the heat generated by, the respective heaters 246 and 248. More particularly, as shown in FIG. 7, the drive leads 282a includes a high and a low pair, which connect across a resistive element 286 of the heater 246. The greater the current provided through the resistive element 286, the hotter the resistive element 286 gets. The heater 248 operates in the same fashion with regard to the drive lead 282b. According to the illustrative embodiments, the element 286 has a resistance of about 5 ohms. However, in other illustrative embodiments, the element may have a resistance of between about 3 ohms and about 10 ohms. As discussed in more detail below with regard to FIGS. 11 and 13, the heaters 246 and 248 may be controlled independently by the processor 150.

[0117] According to the illustrative embodiment, the heater assembly 110 housing components are formed from a molded plastic, for example, polycarbonate, and weighs less than about one pound. More particularly, the housing 234 and the brackets 258, 260, 272 and 274 are all formed from a molded plastic, for example, polycarbonate. According to another feature, the heater assembly is a single use disposable assembly.

[0118] In operation, the illustrative heater assembly 110 uses between about 1 Watt and about 200 Watts of power, and is sized and shaped to transition perfusion fluid 108 flowing through the channel 240 at a rate of between about 300 ml/min and about 5 L/min from a temperature of less than about 30° C. to a temperature of at least about 37° C. in less than about 30 minutes, less than about 25 minutes, less than about 20 minutes, less than about 15 minutes or even less than about 10 minutes, without substantially causing hemolysis of cells, or denaturing proteins or otherwise damaging any blood product portions of the perfusion fluid.

[0119] According to one feature, the heater assembly 110 includes housing components, such as the housing 234 and the brackets 258, 260, 272 and 274, that are formed from a polycarbonate and weighs less than about 5 lb. In other embodiments, the heater assembly may weigh less than about 4 lb, less than about 3 lb, less than about 2 lb, or even less than about 1 lb. In the illustrative embodiment, the heater assembly 110 has a length 288 of about 6.6 inches, not including the inlet 110a and outlet 110b ports, and a width 290 of about 2.7 inches. The heater assembly 110 has a height 292 of about 2.6 inches. The flow channel 240 of the heater assembly 110 has a nominal width 296 of about 1.5 inches, a nominal length 294 of about 3.5 inches, and a nominal height 298 of about 0.070 inches. The height 298 and width 296 are selected to provide for uniform heating of the perfusion fluid 108 as it passes through the channel 240. The height 298 and width 296 are also selected to provide a cross-sectional area within the channel 240 that is approxi-

mately equal to the inside cross-sectional area of fluid conduits that carry the perfusion fluid **108** into and/or away from the heater assembly **110**. In one configuration, the height **298** and width **296** are selected to provide a cross-sectional area within the channel **240** that is approximately equal to the inside cross-sectional area of the inlet fluid conduit **792** (shown below with reference to FIG. 25C) and/or substantially equal to the inside cross-sectional area of the outlet fluid conduit **794** (shown below with reference to FIG. 24E).

[0120] Projections **257a-257d** and **259a-259d** are included in the heater assembly **110** and are used to receive a heat-activated adhesive for binding the heating assembly to the multiple-use unit **650** (referenced in FIG. 20A).

[0121] FIGS. 8A-8C show various views of a pump interface assembly **300** according to an illustrative embodiment of the invention. FIG. 9 shows a perspective view of a pump-driver end of the perfusion fluid pump assembly **106** of FIG. 1, and FIG. 10 shows the pump interface assembly **300** mated with the pump-driver end of the perfusion fluid pump assembly **106**, according to an illustrative embodiment of the invention. Referring to FIGS. 8A-10, the pump interface assembly **300** includes a housing **302** having an outer side **304** and an inner side **306**. The interface assembly **300** includes an inlet **308** and an outlet **310**. As shown most clearly in the bottom view of FIG. 8B and the exploded view of FIG. 8C, the pump interface assembly **300** also includes inner **312** and outer **314** O-ring seals, two deformable membranes **316** and **318**, a doughnut-shaped bracket **320**, and half-rings **319a** and **319b** that fit between the o-ring **314** and the bracket **320**. The half-rings **319a** and **319b** may be made of foam, plastic, or other suitable material.

[0122] The inner O-ring **312** fits into an annular track along a periphery of the inner side **306**. The first deformable membrane **316** mounts over the inner O-ring **312** in fluid tight interconnection with the inner side **306** of the housing **302** to form a chamber between an interior side of the first deformable membrane **316** and the inner side **306** of the housing **302**. A second deformable membrane **318** fits on top of the first deformable membrane **316** to provide fault tolerance in the event that the first deformable membrane **316** rips or tears. Illustratively, the deformable membranes **316** and **318** are formed from a thin polyurethane film (about 0.002 inches thick). However, any suitable material of any suitable thickness may be employed. Referring to FIGS. 8A and 8B, the bracket **320** mounts over the second deformable membrane **318** and the rings **319a** and **319b** and affixes to the housing **302** along a periphery of the inner side **306**. Threaded fasteners **322a-322i** attach the bracket **320** to the housing **302** by way of respective threaded apertures **324a-324i** in the bracket **320**. As shown in FIG. 8B, the outer O-ring **314** interfits into an annular groove in the bracket **320** for providing fluid tight seal with the pump assembly **106**. Prior to inserting O-ring **314** into the annular groove in bracket **320**, the half-rings **319a** and **319b** are placed in the groove. The O-ring **314** is then compressed and positioned within the annular groove in bracket **320**. After being positioned within the annular groove, the O-ring **314** expands within the groove to secure itself and the half-rings **319a** and **319b** in place.

[0123] The pump interface assembly **300** also includes heat stake points **321a-321c**, which project from its outer side **304**. As described in further detail below with reference to FIGS. 21A-21C and 24A-24C, the points **321a-321c**

receive a hot glue to heat-stake the pump interface assembly **300** to a C-shaped bracket **656** of the single use disposable module chassis **635**.

[0124] As shown in FIG. 8C, the fluid outlet **310** includes an outlet housing **310a**, an outlet fitting **310b**, a flow regulator ball **310c** and an outlet port **310d**. The ball **310c** is sized to fit within the outlet port **310d** but not to pass through an inner aperture **326** of the outlet **310**. The fitting **310b** is bonded to the outlet port **310d** (e.g., via epoxy or another adhesive) to capture the ball **310c** between the inner aperture **326** and the fitting **310b**. The outlet housing **310a** is similarly bonded onto the fitting **310b**.

[0125] In operation, the pump interface assembly **300** is aligned to receive a pumping force from a pump driver **334** of the perfusion fluid pump assembly **106** and translate the pumping force to the perfusion fluid **108**, thereby circulating the perfusion fluid **108** to the organ chamber assembly **104**. According to the illustrative embodiment, the perfusion fluid pump assembly **106** includes a pulsatile pump having a driver **334** (described in further detail below with regard to FIG. 9), which contacts the membrane **318**. The fluid inlet **308** draws perfusion fluid **108**, for example, from the reservoir **160**, and provides the fluid into the chamber formed between the inner membrane **316** and the inner side **306** of the housing **302** in response to the pump driver moving in a direction away from the deformable membranes **316** and **318**, thus deforming the membranes **316** and **318** in the same direction. As the pump driver moves away from the deformable membranes **316** and **318**, the pressure head of the fluid **108** inside the reservoir **160** causes the perfusion fluid **108** to flow from the reservoir **160** into the pump assembly **106**. In this respect, the pump assembly **106**, the inlet valve **191** and the reservoir **160** are oriented to provide a gravity feed of perfusion fluid **108** into the pump assembly **106**. At the same time, the flow regulator ball **310c** is drawn into the aperture **326** to prevent perfusion fluid **108** from also being drawn into the chamber through the outlet **310**. It should be noted that the outlet valve **310** and the inlet valve **191** are one way valves in the illustrated embodiment, but in alternative embodiments the valves **310** and/or **191** are two-way valves. In response to the pump driver **334** moving in a direction toward the deformable membranes **316** and **318**, the flow regulator ball **310c** moves toward the fitting **310b** to open the inner aperture **326**, which enables the outlet **310** to expel perfusion fluid **108** out of the chamber formed between the inner side **306** of the housing **302** and the inner side of the deformable membrane **316**. A separate one-way inlet valve **191**, shown between the reservoir **160** and the inlet **308** in FIG. 1, stops any perfusion fluid from being expelled out of the inlet **308** and flowing back into the reservoir **160**.

[0126] As discussed in further detail below with respect to FIGS. 18A-27B, in certain embodiments the organ care system **100** mechanically divides into a disposable single-use unit (shown at **634** in FIGS. 19A-19C and 24A-25C) and a non-disposable multi-use unit (shown at **650** in FIG. 20A). In such embodiments, the pump assembly **106** rigidly mounts to the multiple use module **650**, and the pump interface assembly **300** rigidly mounts to the disposable single use module **634**. The pump assembly **106** and the pump interface assembly **300** have corresponding interlocking connections, which mate together to form a fluid tight seal between the two assemblies **106** and **300**.

[0127] More particularly, as shown in the perspective view of FIG. 9, the perfusion fluid pump assembly 106 includes a pump driver housing 338 having a top surface 340, and a pump driver 334 housed within a cylinder 336 of the housing 338. The pump driver housing 338 also includes a docking port 342, which includes a slot 332 sized and shaped for mating with a flange 328 projecting from the pump interface assembly 300. As shown in FIG. 10, the top surface 340 of the pump driver housing 338 mounts to a bracket 346 on the non-disposable multiple use module unit 650. The bracket 346 includes features 344a and 344b for abutting the tapered projections 323a and 323b, respectively, of the pump interface assembly 300. The bracket 346 also includes a cutout 330 sized and shaped for aligning with the docking port 342 and the slot 332 on the pump driver housing 338.

[0128] Operationally, the seal between the pump interface assembly 300 and the fluid pump assembly 106 is formed in two steps, illustrated with reference to FIGS. 9 and 10. In a first step, the flange 328 is positioned within the docking port 342, while the tapered projections 323a and 323b are positioned on the clockwise side next to corresponding features 344a and 344b on the bracket 346. In a second step, as shown by the arrows 345, 347 and 349 in FIG. 9, the pump interface assembly 300 and the fluid pump assembly 106 are rotated in opposite directions (e.g., rotating the pump interface assembly 300 in a counter clockwise direction while holding the pump assembly 106 fixed) to slide the flange 328 into the slot 332 of the docking port 342. At the same time, the tapered projections 323a and 323b slide under the bracket features 344a and 344b, respectively, engaging inner surfaces of the bracket features 344a and 344b with tapered outer surfaces of the tapered projections 323a and 323b to draw the inner side 306 of the pump interface assembly 300 toward the pump driver 334 and to interlock the flange 328 with the docking ports 342, and the tapered projections 323a and 323b with the bracket features 344a and 344b to form the fluid tight seal between the two assemblies 300 and 106.

[0129] Having described the illustrative organ care system 100 from a system, operational and component point of view, illustrative control systems and methods for achieving operation of the system 100 are next discussed. More particularly, FIG. 11 depicts a block diagram of an illustrative control scheme for the system 100. As described above with reference to FIG. 1, the system 100 includes a controller 150 for controlling operation of the system 100. As shown, the controller 150 connects interoperationally with the following six subsystems: an operator interface 146 for assisting an operator in monitoring and controlling the system 100 and in monitoring the condition of the heart 102; a data acquisition subsystem 147 having various sensors for obtaining data relating to the heart 102 and to the system 100, and for conveying the data to the controller 150; a power management subsystem 148 for providing fault tolerant power to the system 100; a heating subsystem 149 for providing controlled energy to the heater 110 for warming the perfusion fluid 108; a data management subsystem 151 for storing and maintaining data relating to operation of the system 100 and with respect to the heart 102; and a pumping subsystem 153 for controlling the pumping of the perfusion fluid 108 through the system 100. It should be noted that although the system 100 is described conceptually with reference to a single controller 150, the control of the system 100 may be distributed in a plurality of controllers or

processors. For example, any or all of the described subsystems may include a dedicated processor/controller. Optionally, the dedicated processors/controllers of the various subsystems may communicate with and via a central controller/processor.

[0130] FIGS. 12-17J illustrate the interoperation of the various subsystems of FIG. 11. Referring first to the block diagram of FIG. 12, the data acquisition subsystem 147 includes sensors for obtaining information pertaining to how the system 100 and the heart 102 is functioning, and for communicating that information to the controller 150 for processing and use by the system 100. As described with respect to FIG. 1, the sensors of subsystem 147 include, without limitation: temperature sensors 120, 122 and 124; pressure sensors 126, 128, and 130; flow rate sensors 134, 136 and 138; the oxygenation/hematocrit sensor 140; and electrodes 142 and 144. The data acquisition subsystem 147 also includes: a set of Hall sensors 388 and a shaft encoder 390 from the perfusion pump assembly 106; battery sensors 362a-362c for sensing whether the batteries 352a-352c, respectively, are sufficiently charged; an external power available sensor 354 for sensing whether external AC power is available; an operator interface module battery sensor 370 for sensing a state of charge of the operator interface module battery; and a gas pressure sensor 132 for sensing gas flow from the gas flow chamber 176. How the system 100 uses the information from the data acquisition subsystem 147 will now be described with regard to the heating 149, power management 148, pumping 153, data management 151, and operator interface 146 subsystems, shown in further detail in FIGS. 13-17J, respectively.

[0131] The heating subsystem 149 is depicted in the block diagram of FIG. 13. With continued reference also to FIG. 1, the heating subsystem 149 controls the temperature of the perfusion fluid 108 within the system 100 through a dual feedback loop approach. In the first loop 251 (the perfusion fluid temperature loop), the perfusion fluid temperature thermistor sensor 124 provides two (fault tolerant) signals 125 and 127 to the controller 150. The signals 125 and 127 are indicative of the temperature of the perfusion fluid 108 as it exits the heater assembly 110. The controller 150 regulates the drive signals 285 and 287 to the drivers 247 and 249, respectively. The drivers 247 and 249 convert corresponding digital level signals 285 and 287 from the controller 150 to heater drive signals 281 and 283, respectively, having sufficient current levels to drive the first 246 and second 248 heaters to heat the perfusion fluid 108 to within an operator selected temperature range. In response to the controller 150 detecting that the perfusion fluid temperatures 125 and 127 are below the operator-selected temperature range, it sets the drive signals 281 and 283 to the first 246 and second 248 heaters, respectively, to a sufficient level to continue to heat the perfusion fluid 108. Conversely, in response to the controller 150 detecting that the perfusion fluid temperatures 125 and 127 are above the operator-selected temperature range, it decreases the drive signals 281 and 283 to the first 246 and second 248 heaters, respectively. In response to detecting that the temperature of the perfusion fluid 108 is within the operator-selected temperature range, the controller 150 maintains the drive signals 281 and 283 at constant or substantially constant levels.

[0132] Preferably, the controller 150 varies the drive signals 281 and 283 in substantially the same manner. However, this need not be the case. For example, each heater 246

and 248 may respond differently to a particular current or voltage level drive signal. In such a case, the controller 150 may drive each heater 246 and 248 at a slightly different level to obtain the same temperature from each. According to one feature, the heaters 246 and 248 each have an associated calibration factor, which the controller 150 stores and employs when determining the level of a particular drive signal to provide to a particular heater to achieve a particular temperature result. In certain configurations, the controller 150 sets one of the thermistors in dual sensor 124 as the default thermistor, and will use the temperature reading from the default thermistor in instances where the thermistors give two different temperature readings. In certain configurations, where the temperature readings are within a pre-defined range, the controller 150 uses the higher of the two readings. The drivers 247 and 249 apply the heater drive signals 281 and 283 to corresponding drive leads 282a and 282b on the heater assembly 110.

[0133] In the second loop 253 (the heater temperature loop), the heater temperature sensors 120 and 122 provide signals 121 and 123, indicative of the temperatures of the heaters 246 and 248, respectively, to the controller 150. According to the illustrated embodiment, a temperature ceiling is established for the heaters 246 and 248 (e.g., by default or by operator selection), above which the temperatures of the heaters 246 and 248 are not allowed to rise. As the temperatures of the heaters 246 and 248 rise and approach the temperature ceiling, the sensors 121 and 123 indicate the same to the controller 150, which then lowers the drive signals 281 and 283 to the heaters 246 and 248 to reduce or stop the supply of power to the heaters 246 and 248. Thus, while a low temperature signal 125 or 127 from the perfusion fluid temperature sensor 124 can cause the controller 150 to increase power to the heaters 246 and 248, the heater temperature sensors 120 and 122 ensure that the heaters 246 and 248 are not driven to a degree that would cause their respective heater plates 250 and 252 to become hot enough to damage the perfusion fluid 108. According to various illustrative embodiments, the controller 150 is set to maintain the perfusion fluid temperature at between about 32° C. and about 37° C., or between about 34° C. and about 36° C. According to a further illustrative embodiment, the controller 150 is set to limit the maximum temperature of the heater plates 250 and 252 to less than about 38° C., 39° C., 40° C., 41° C., or 42° C.

[0134] As can be seen, the second loop 253 is configured to override the first loop 251, if necessary, such that temperature readings from temperature sensors 120 and 122 indicating that the heaters 246 and 248 are approaching the maximum allowable temperature override the effect of any low temperature signal from the perfusion fluid temperature sensor 124. In this respect, the subsystem 149 ensures that the temperature of the heater plates 250 and 252 do not rise above the maximum allowable temperature, even if the temperature of the perfusion fluid 108 has not reached the operator-selected temperature value. This override feature is particularly important during failure situations. For example, if the perfusion fluid temperature sensors 124 both fail, the second loop 253 stops the heater assembly 110 from overheating and damaging the perfusion fluid 108 by switching control exclusively to the heater temperature sensors 120 and 122 and dropping the temperature set point to a lower value. According to one feature, the controller 150 takes into account two time constants assigned to the delays associated

with the temperature measurements from the heaters 246 and 248 and perfusion fluid 108 to optimize the dynamic response of the temperature controls.

[0135] FIG. 14 depicts a block diagram of the power management system 148 for providing fault tolerant power to the system 100. As shown, the system 100 may be powered by one of four sources—by an external AC source 351 (e.g., 60 Hz, 120 VAC in North America or 50 Hz, 230 VAC in Europe) or by any of three independent batteries 352a-352c. The controller 150 receives data from an AC line voltage availability sensor 354, which indicates whether the AC voltage 351 is available for use by the system 100. In response to the controller 150 detecting that the AC voltage 351 is not available, the controller 150 signals the power switching circuitry 356 to provide system power high 358 from one of the batteries 352a-352c. The controller 150 determines from the battery charge sensors 362a-362c which of the available batteries 352a-352c is most fully charged, and then switches that battery into operation by way of the switching network 356.

[0136] Alternatively, in response to the controller 150 detecting that the external AC voltage 351 is available, it determines whether to use the available AC voltage 351 (e.g., subsequent to rectification) for providing system power 358 and for providing power to the user interface module 146, for charging one or more of the batteries 352a-352c, and/or for charging the internal battery 368 of user interface module 146, which also has its own internal charger and charging controller. To use the available AC voltage 351, the controller 150 draws the AC voltage 351 into the power supply 350 by signaling through the switching system 364. The power supply 350 receives the AC voltage 351 and converts it to a DC current for providing power to the system 100. The power supply 350 is universal and can handle any line frequencies or line voltages commonly used throughout the world. According to the illustrative embodiment, in response to a low battery indication from one or more of the battery sensors 362a-362c, the controller 150 also directs power via the switching network 364 and the charging circuit 366 to the appropriate battery. In response to the controller 150 receiving a low battery signal from the sensor 370, it also or alternatively directs a charging voltage 367 to the user interface battery 368. According to another feature, the power management subsystem 148 selects batteries to power the system 100 in order of least-charged first, preserving the most charged batteries. If the battery that is currently being used to power the system 100 is removed by the user, the power management subsystem 148 automatically switches over to the next least-charged battery to continue powering the system 100.

[0137] According to another feature, the power management subsystem 148 also employs a lock-out mechanism to prevent more than one of the batteries 352a-352c from being removed from the system 100 at a given time. If one battery is removed, the other two are mechanically locked into position within the system 100. In this respect, the system 148 provides a level of fault tolerance to help ensure that a source of power 358 is always available to the system 100.

[0138] The pumping subsystem 153 of FIG. 11 will now be described in further detail with reference to FIGS. 15 and 16. More particularly, FIG. 15 is a conceptual block diagram depicting the illustrative pumping subsystem 153, and FIG. 16 shows an exemplary ECG 414 of a heart 102 synchronized with an exemplary wave 385 depicting pumping

output by the subsystem 153. The ECG 414 shown in FIG. 16 has P, Q, R, S, T, and U peaks. The pumping subsystem 153 includes the perfusion fluid pump 106 interoperationally connected to the pump interface assembly 300, as described in more detail above with reference to FIGS. 8A-10. As shown in FIG. 15, the controller 150 operates the pumping subsystem 153 by sending a drive signal 339 to a brushless three-phase pump motor 360 using Hall Sensor feedback. The drive signal 339 causes the pump motor shaft 337 to rotate, thereby causing the pump screw 341 to move the pump driver 334 up and/or down. According to the illustrative embodiment, the drive signal 339 is controlled to change a rotational direction and rotational velocity of the motor shaft 337 to cause the pump driver 334 to move up and down cyclically. This cyclical motion pumps the perfusion fluid 108 through the system 100.

[0139] In operation, the controller 150 receives a first signal 387 from the Hall sensors 388 positioned integrally within the pump motor shaft 337 to indicate the position of the pump motor shaft 337 for purposes of commutating the motor winding currents. The controller 150 receives a second higher resolution signal 389 from a shaft encoder sensor 390 indicating a precise rotational position of the pump screw 341. From the current motor commutation phase position 387 and the current rotational position 389, the controller 150 calculates the appropriate drive signal 339 (both magnitude and polarity) to cause the necessary rotational change in the motor shaft 337 to cause the appropriate vertical position change in the pump screw 341 to achieve the desired pumping action. By varying the magnitude of the drive signal 339, the controller 150 can vary the pumping rate (i.e., how often the pumping cycle repeats) and by varying the rotational direction changes, the controller 150 can vary the pumping stroke volume (e.g., by varying how far the pump driver 334 moves during a cycle). Generally speaking, the cyclical pumping rate regulates the pulsatile rate at which the perfusion fluid 108 is provided to the heart 102, while (for a given rate) the pumping stroke regulates the volume of perfusion fluid 108 provided to the heart 102.

[0140] Both the rate and stroke volume affect the flow rate, and indirectly the pressure, of the perfusion fluid 108 to and from the heart 102. As mentioned with regard to FIG. 1, the system includes three flow rate sensors 134, 136 and 138, and three pressure sensors 126, 128 and 130. As shown in FIG. 15, the sensors 134, 136, and 138 provide corresponding flow rate signals 135, 137 and 139 to the controller 150. Similarly, the sensors 126, 128 and 130 provide corresponding pressure signals 129, 131 and 133 to the controller 150. The controller 150 employs all of these signals in feedback to ensure that the commands that it is providing to the perfusion pump 106 have the desired effect on the system 100. In some instances, and as discussed below in further detail with reference to FIGS. 17A-17J, the controller 150 may generate various alarms in response to a signal indicating that a particular flow rate or fluid pressure is outside an acceptable range. Additionally, employing multiple sensors enables the controller 150 to distinguish between a mechanical issue (e.g., a conduit blockage) with the system 100 and a biological issue with the heart 102.

[0141] According to one feature of the invention, the pumping system 153 may be configured to control the position of the pump driver 334 during each moment of the pumping cycle to allow for finely tuned pumping rate and volumetric profiles. This in turn enables the pumping system

153 to supply perfusion fluid 108 to the heart with any desired pulsatile pattern. According to one illustrative embodiment, the rotational position of the shaft 337 is sensed by the shaft encoder 390 and adjusted by the controller 150 at least about 100 increments per revolution. In another illustrative embodiment, the rotational position of the shaft 337 is sensed by the shaft encoder 390 and adjusted by the controller 150 at least about 1000 increments per revolution. According to a further illustrative embodiment, the rotational position of the shaft 337 is sensed by the shaft encoder 390 and adjusted by the controller 150 at least about 2000 increments per revolution. The vertical position of the pump screw 341 and thus the pump driver 334 is calibrated initially to a zero or a ground position, corresponding to a reference position of the pump screw 341.

[0142] According to the illustrative embodiment, the positional precision of the pumping subsystem 153 enables the controller 150 to precisely regulate the pumping of the perfusion fluid 108 through the heart 102. This process of synchronizing the pulsatile flow of the perfusion fluid to the heart's natural rate is referred to herein as "r-wave synchronization," which is described with continued reference to FIGS. 2, 15, and 16. A normally functioning heart has a two-phase pumping cycle—diastole and systole. During the diastolic phase, also known as the "resting phase," the heart's atria 157 and 152 contract, causing valves to open between the atria 157 and 152 and the ventricles 154 and 156 to allow blood to flow into and load the ventricles 154 and 156. During the systolic phase, the loaded ventricles eject the blood, and the atria 157 and 152 are opened and fill with blood. The cyclical expansion and contraction of the heart 102 during this process can be represented by graphing the heart's ventricular ECG wave form, shown at 414 in FIG. 16. FIG. 16 depicts the ECG waveform 414 synchronized with an exemplary wave 385 representative of a pumping output by the subsystem 153.

[0143] The pumping subsystem 153 is configured to provide the maximum output at a time that will result in delivery of fluid 108 to the heart 102 at the most beneficial time. In the illustrated embodiment, in retrograde mode, the pumping subsystem 153 is configured to pump fluid 108 toward the heart 102 so that the maximum pump output 382 occurs during the diastolic phase of the heart, which begins after the S peak shown in FIG. 16 and is when the left ventricle 156 has finished ejecting perfusion fluid 108 through the aorta 158. Timing the pump output in this manner allows the user to maximize the injection of perfusion fluid 108 through the aorta 158 and into the coronary sinus 155. The timed pumping is accomplished by starting the pumping at point 377 on wave 385, which is a point prior to point 382 and corresponds to the peak of the heart's r-wave pulse 380 and the middle of ventricular systole. The point 377 is selected to account for time-delay between the time a signal is provided from the controller 150 to start pumping the fluid and the time of actual delivery of the pumped fluid 108 to the heart 102. In another example, during normal flow mode where the left side of the heart fills and ejects perfusion fluid (as described in more detail with reference to FIG. 24A), the controller 150 synchronizes the pumping subsystem 153 to start pumping at a fixed period of time after the r-wave 380, so as to match the natural filling cycle of the left atrium 152. The synchronization may be adjusted and fine-tuned by the operator through a pre-programmed routine in the operating software on the system

100 and/or by manually operating the controls of the user interface display area 410, as described in more detail below in reference to FIGS. 17A-17J.

[0144] To achieve the synchronized pump output, the controller 150 predicts when the heart's r-wave pulses 380 will occur and causes the pump to pump at the appropriate time during the ECG 414. To make this prediction, the controller 150 measures the length various r-wave pulses 380 from the electrical signals 379 and 381 provided from the electrodes 142 and 144, respectively. From these pulses, the controller 150 tracks the time that elapses from one pulse 380 to the next, and uses this information to calculate a running average of the length of time separating two sequential r-wave pulses. From this information, the controller 150 projects the time of the next r-wave (and from the projection determines the time prior to or after that projected r-wave when the pumping should start to achieve optimal output delivery) by adding the average time separating two sequential r-wave pulses to the time of the previous r-wave 380. Based on this running average of separation time between r-waves, the controller 150 has the option to adjust the time of pump output in relation to subsequent r-waves, as reflected in the movement of wave 385 to the left or the right along the ECG 414 as signified by the arrow 383 in FIG. 16. Adjusting the wave 385 thus allows the user to adjust and customize the timing of output by the pump 106 so as to optimize the filling of the heart. In addition, the pump 106 may also be adjusted to increase or decrease the pump stroke volume to customize the volume of fluid 108 provided by the pump 106, and this may be done either in concert with or independent of the r-wave synchronization.

[0145] It should be noted that although the subsystem 153 particularly synchronizes with the r-wave cycle 385, this need not be the case. In alternative illustrative embodiments, the subsystem 153 may pump in synchronicity with any available characteristic of the heart, including fluid pressures into or out of a particular chamber or vessel. Also, the subsystem 153 may be programmed to pump in any arbitrary pattern, whether periodic or not.

[0146] Referring back to FIG. 11, the data management subsystem 151 receives and stores data and system information from the various other subsystems. The data and other information may be downloaded to a portable memory device and organized within a database, as desired by an operator. The stored data and information can be accessed by an operator and displayed through the operator interface subsystem 146.

[0147] Turning now to the operator interface subsystem 146, FIGS. 17A-17J show various illustrative display screens of the operator interface subsystem 146. The display screens of FIGS. 17A-17J enable the operator to receive information from and provide commands to the system 100. FIG. 17A depicts a top level "home page" display screen 400 according to an illustrative embodiment of the invention. From the display screen 400 an operator can access all of the data available from the data acquisition subsystem 147, and can provide any desired commands to the controller 150. As described in more detail in reference to FIGS. 17B-17J, the display screen 400 of FIG. 17A also allows the operator to access more detailed display screens for obtaining information, providing commands and setting operator selectable parameters.

[0148] With continued reference to FIG. 1, the display screen 400 includes a display area 402, which shows a

number of numerical and graphical indications pertaining to the operation of the system 100. In particular, the display area 402 includes a numerical reading of the aorta output pressure (AOP) 404 of the perfusion fluid 108 exiting the aorta interface 162 on the organ chamber assembly 104, a wave form depiction 406 of the aortic fluid pressure (AOP) 404, and an AOP alarm image 408 indicating whether the fluid pressure 404 is too high or too low (the alarm 408 is shown as "off" in FIG. 17A). The display screen 400 also includes a display area 410 having a numerical indication 412 of the rate at which the heart 102 is beating, an ECG 414 of the heart 102, a heart rate (HR) alarm image 416 indicating whether the HR 412 exceeds or falls below operator set thresholds, and a time log 418 indicating how long the system 100 has been running, including priming time (discussed in further detail below with reference to FIG. 29A). A numerical display 419 shows the amount of time for which the system 100 has been supporting the heart 102. The indicator alarm 413 indicates when an operator preset time limit is exceeded.

[0149] The display screen 400 includes a number of additional display areas 420, 424, 432, 438, 444, 450, 456, 460, 462, 466, 472, 480, and 482. The display area 420 shows a numerical reading of the pulmonary artery pressure (PAP) 422. The PAP 422 is an indication of the pressure of the perfusion fluid 108 flowing from the heart's pulmonary artery 164, as measured by the pressure sensor 130. The display area 420 also provides a PAP alarm indicator 424, which signals when the PAP 422 is outside an operator preset range. The display area 426 indicates the temperature (Temp) 428 of the perfusion fluid 108 as it exits the heater 110. The display area 426 also includes a Temp alarm indicator 430, which signals in response to the Temp 428 being outside of an operator preset range. The upper limit of the operator preset range is shown at 427. The display area 432 shows a numerical reading of the hematocrit (HCT) 434 of the perfusion fluid 108, and an HCT alarm indicator 436 for signaling the operator if the HCT 434 falls below an operator preset threshold. The display area 438 shows the oxygen saturation (SvO₂) 440 of the perfusion fluid 108. The display area 438 also includes a SvO₂ alarm 442 for indicating if the SvO₂ 440 of the perfusion fluid 108 falls below an operator preset threshold. The display area 444 indicates the aorta output flow rate (AOF) 446 of the perfusion fluid 108 as it flows out of the aorta 158. The AOF 446 is measured by the flow rate sensor 134. The AOF alarm 448 indicates whether the flow rate 446 falls outside of an operator preset range. The display area 450 shows the organ chamber flow rate (CF) 452. The CF 452 is an indication of the flow rate of the perfusion fluid 108 as it exits the organ chamber 104, as measured by the flow rate sensor 136. The display area 450 also includes a CF alarm 454, which signals in response to the CF 454 falling outside of an operator preset range. The display area 456 includes a graphic 458 for indicating when a file transfer to the memory card is occurring.

[0150] The display area 460 shows a graphical representation 459 of the degree to which each of the batteries 352a-352c (described above with reference to FIG. 14) is charged. The display area 460 also provides a numerical indication 461 of the amount of time remaining for which the batteries 352a-352c can continue to run the system 100 in a current mode of operation. The display area 462 identifies whether the operator interface module 146 is

operating in a wireless 464 fashion, along with a graphical representation 463 of the strength of the wireless connection between the operator interface module 146 and the remainder of the system 100. The display area 462 also provides graphical indication 467 of the charge remaining in the operator interface module battery 368 (described above with reference to FIG. 14) and a numerical indication 465 of the amount of time remaining for which the operator interface module battery 368 can support it in a wireless mode of operation. The display area 466 indicates the flow rate 468 of oxygen from the gas flow chamber 176. It also provides a graphical indication 469 of how full an onboard oxygen tank is, and a numerical indication 470 of the amount of time remaining before the onboard oxygen tank runs out. The display area 472 shows the heart rate of the heart 102, and the amount of time 476 for which the heart 102 has been cannulated onto the system 100. This field is duplicative of the field 419 mentioned above. The display areas 480 and 482 show the current time and date, respectively, of operation of the system 100.

[0151] Actuating a dial (or mouse, or other control device), such as the dial 626 shown in FIG. 18A, on the operator interface 146 opens a configuration menu 484, such as shown in the display screen 401 of FIG. 17B. As shown, accessing the configuration menu 484 covers the display areas 402 and 410 so they no longer show the graphical depictions of the pressure 406 and the heart rate 414, but continue to display critical alpha/numeric information. As also shown, all other display areas remain unchanged. This enables an operator to adjust operation of the system 100 while continuing to monitor critical information. According to one feature, the configuration menu 484 allows the operator to pre-program desired operational parameters for the system 100. Using the display screen 401, the operator can view/edit working and diastolic (or retrograde) mode alarms by selecting the fields 488 and 490, respectively. The operator can set particular ECG and LAP graphical options by selecting the fields 492 and 494. Additionally, the operator can set oxygen flow rate and perfusion fluid temperature by selecting the fields 496 and 498, respectively. Selecting the field 500 enables the operator to set the time and date, while selecting the field 502 enables the operator to select the language in which information is displayed. At the bottom of the display field 484, the operator has the option to return 504 to the display screen 400, cancel 506 any changes made to operational settings, save 508 the changes as new defaults, or reset 510 the operational settings to factory defaults.

[0152] Referring to FIGS. 17C-17D, selecting the view/edit working mode alarms field 488 causes the working mode alarm dialog 512 of FIG. 17D to open within the display field 484 of FIG. 17C. The working mode dialog 512 displays the parameters associated with normal flow mode (described above with reference to FIGS. 1 and 3) and includes a field for setting numerical thresholds for each of the normal flow mode alarms. More specifically, the dialog 512 includes: CF alarm field 514; PAP alarm field 516; AOP alarm field 518; LAP alarm field 520; perfusion fluid Temp alarm field 524; SvO₂ alarm field 526; HCT alarm field 528; and HR alarm field 530. By selecting a particular alarm field and actuating the up 532 and/or down 534 arrows, a operator can adjust the acceptable upper and/or lower thresholds for each of the parameters associated with each of the alarms. The dialog 512 also includes alarm graphics 536a-536i, each

of which being associated with a particular normal flow mode alarm. The operator can enable/disable any of the above normal flow mode alarms by selecting the associated alarm graphic 536a-536i. Any changes made using the dialog 512 are reflected in corresponding fields in the display screen 400 of FIG. 17A.

[0153] Referring to FIGS. 17A, 17B and 17E, selecting the view/edit non-working mode alarms field 490 causes the resting mode alarm dialog 538 of FIG. 17E to open within the display field 484 of FIG. 17C. The resting mode dialog 538 displays the parameters associated with retrograde flow mode (described above with reference to FIGS. 1 and 4) and includes a field for setting numerical thresholds for each of the retrograde flow mode alarms. According to the illustrative embodiment, the available alarms for the normal and retrograde flow modes are similar, but not necessarily the same. Additionally, even for those that are the same, the thresholds may differ. Accordingly, the invention enables the operator to select different alarms and/or different thresholds for each flow mode of operation. More specifically, the dialog 538 includes: CF alarm field 540; PAP alarm field 542; AOF alarm field 544; AOP alarm field 546; LAP alarm field 548; perfusion fluid Temp alarm field 550; SvO₂ alarm field 552; HCT alarm field 556; and HR alarm field 558. By selecting a particular alarm field and actuating the up 560 and/or down 562 arrows, an operator can adjust the acceptable numerical upper and/or lower thresholds for each of the parameters associated with each of the alarms. The dialog 538 also includes alarm graphics 564a-564i, each of which being associated with a particular normal flow mode alarm. The operator can enable/disable any of the above normal flow mode alarms by selecting the associated alarm graphic 564a-564i. As is the case of the dialog 512, any changes made using the dialog 538 are reflected in corresponding fields in the display screen 400 of FIG. 17A. In one implementation, the system 100 may be configured to automatically switch between sets of alarm limits for a given flow mode upon changing the flow mode.

[0154] Referring to FIGS. 17A, 17B, 17F and 17G, the operator interface 146 also provides graphical mechanisms for adjusting various parameters. For example, as noted above in reference to FIG. 16, one advantage of the user display area 402 is that it allows the operator to monitor (and adjust) the pumping of the subsystem 153. Display area 410 identifies the ECG waveform 414 of the heart 102, and display 402 shows in wave form 406 the pressure of fluid flowing through the aorta. In these two displays the operator can monitor the effect of the pumping profile on the heart's ECG 414, which allows the user to adjust the stroke volume of the pumping subsystem 153, to adjust the rate of the pumping subsystem 153 (and thus the flow-rate of the fluid 108 being pumped through the system 100), to manually impose, or adjust a time of, firing of the subsystem (e.g., by imposing a fixed delay between the r-wave 380 and the beginning of the pumping cycle), or to automatically program the pumping subsystem 153 to pump at a pre-determined time along the heart's ECG waveform 414, as needed to properly fill the heart according to whether the heart is being perfused in retrograde or normal mode. These pumping adjustments may be made by use of the various graphical frames of the operator interface 146. By way of example, in response to a operator selecting the ECG graphic frame option 492 located in the display field 484 of the display screen 401, the operator interface 146 displays the dialog

568 of FIG. 17F. The dialog **568** shows a graphical representation **572** of the ECG **414** along with a cursor **570**. The position of the cursor **570** indicates the point at which the pumping subsystem **153** will initiate an output pumping stroke (i.e., the portion of the pumping cycle at which the pump motor **106** will push perfusion fluid **108** to the heart **102**) relative to the ECG **414** of the heart **102**. By rotating a mechanical knob **626** (shown in FIGS. **18A** and **18B**) on the operator interface **146**, the operator moves the position of the cursor **570** to adjust when the pumping subsystem **153** will initiate the output pumping stroke relative to the r-wave pulse **380**. As described above with regard to FIGS. **15** and **16**, the pumping subsystem **153** receives an r-wave signal **380** from the ECG sensors **142** and **144**. The pumping subsystem **153** uses the r-wave signal **380** along with the pumping adjustment information from the cursor **570** to synchronize perfusion fluid pumping with the beating of the heart **102**. In another example, in response to the operator pressing the pump adjust button **625**, the operator interface **146** displays the dialog **574** of FIG. 17G. From the dialog **574**, the operator can select the pointer **576** and rotate the knob **626** to turn the pump motor **106** on and off. Additionally, the operator can select the bar graphic **578** and rotate the knob **626** to adjust the volume of fluid being pumped, which is displayed in liters/minute.

[**0155**] The operator interface **146** also provides a plurality of warning/reminder messages. By way of example, in FIG. 17H, the operator interface **146** displays a message to remind the operator to connect to AC power to recharge the batteries. This message appears, for example, in response to the controller **150** detecting an impending low battery condition. The operator interface **146** displays the message of FIG. 17I to confirm that the user wishes to enter standby mode and to remind the operator to insert a portable memory device, such as magnetic or optical disk, a portable disk drive, a flash memory card or other suitable memory device, to download and store information regarding a particular use of the system **100**. The operator interface **146** displays the error messages, such as the error message of FIG. 17J, in response to an identifiable fault occurring. The error messages of FIG. 17J include, for example, error information **580** to aid a service technician in diagnosing and/or repairing the fault.

[**0156**] Having described an illustrative control systems and methods for achieving operation of the system **100**, illustrative mechanical features of the system **100** will now be discussed, along with an illustrative division of components between the single use disposable module **634** and multiple use module **650** units. More particularly, FIGS. **18A-18B** show a mechanical implementation **600** of the system of FIG. **1**, according to an illustrative embodiment of the invention. As shown, the illustrative implementation **600** includes a housing **602** and a cart **604**. The housing **602** conceptually divides into upper **602a** and lower **602b** housing sections, and includes front **606a**, rear **606b**, left **606c**, and right **606d** sides. The cart **604** includes a platform **608** and wheels **610a-610d** for transporting the system **600** from place to place. A latch **603** secures the housing **602** to the cart **604**. To further aid in portability, the system **600** also includes a handle **610** hinge mounted to the upper section **602a** of the left side **606c** of the housing **602**, along with two rigidly mounted handles **612a** and **612b** mounted on the lower section **602b** of the left **606c** and right **606d** sides of the housing **602**.

[**0157**] The housing **602** further includes a removable top **614**, and a front panel **615** having an upper panel **613**, and a mid panel **616** hinged to a lower panel **617** by hinges **616a** and **616b**. The top **614** includes handles **614a** and **614b** for aiding with removal. In the illustrated embodiment, the upper panel **613** is screwed, bolted or otherwise adjoined to the top **614**, such that removal of the top **614** also removes panel **613**.

[**0158**] As shown in FIG. **18A**, the system **600** includes an AC power cable **618**, along with a frame **620** for securing the power cable **618**, both located on the lower section **602b** of the left side **606c** of the housing **602**. A software reset switch **622**, also located on the lower section **602b** of the left side **606c**, enables an operator to restart the system software and electronics.

[**0159**] As shown in FIGS. **18A** and **18B**, the implementation **600** also includes the operator interface module **146**, along with a cradle **623** for holding the operator interface module **146**. The operator interface module **146** includes a display **624** for displaying information to an operator, for example, by way of the display screens of FIGS. **17A-17J**. As mentioned above, the operator interface module **146** also includes a rotatable and depressible knob **626** for selecting between the various parameters and display screens of FIGS. **17A-17J**. The knob **626** may also be used to set parameters for automatic control of the system **100**, as well as to provide manual control over the operation of the system **100**. For example, the knob **626** may be used to provide instructions to the controller **150** to increase perfusion fluid flow rates, gas flow rates, etc. As also discussed above with regard to FIGS. **1**, **14** and **17A-17J**, the operator interface module **146** includes its own battery **368** and may be removed from the cradle **623** and used in a wireless mode. While in the cradle **623**, power connections enable the operator interface module **146** to be charged. As shown, the operator interface module also includes control buttons **625** for controlling the pump, silencing or disabling alarms, entering or exiting standby mode, entering or adjusting ECG synchronization mode, and starting the perfusion clock, which initiates the display of data obtained during organ care.

[**0160**] As shown in FIG. **18B**, the illustrative implementation **600** also includes a battery compartment **628** and an oxygen tank bay **630**, both located on the lower section **602b** of the right side **606d** of the housing **602**. As shown, the battery compartment **628** houses the three system batteries **352a-352c**, described above with regard to FIG. **14**. According to one feature, the battery compartment **626** includes three battery locks **632a-632c**. As described above with respect to FIG. **14**, the battery locks **632a-632c** interoperate mechanically so that only one of the three batteries **352a-352c** may be removed at any given time.

[**0161**] The disposable module **634** and the multiple use unit **650** are constructed of material that is durable yet light-weight. In some illustrative embodiments, polycarbonate plastic is used to form one or more of the components of the units **634** and **650**. To further reduce the weight, the chassis **635** and the multiple use module chassis **602** are formed from low weight materials such as, for example, carbon fiber epoxy composites, polycarbonate ABS-plastic blend, glass reinforced nylon, acetal, straight ABS, aluminum or magnesium. According to one illustrative embodiment, the weight of the entire system **600** is less than about 85 pounds, including the multiple use module, heart, batteries, gas tank, and priming, nutritional, preservative and

perfusion fluids, and less than about 50 pounds, excluding such items. According to another illustrative embodiment, the weight of the disposable module 634 is less than about 12 pounds, excluding any solutions. According to a further illustrative embodiment, the multiple use module 650, excluding all fluids, batteries 352a-352c and oxygen supply 172, weighs less than about 50 pounds.

[0162] With continued reference to FIGS. 19A-19C, various views are shown of the implementation 600 of FIGS. 18A and 18B with the top 614 and upper front panel 613 removed and the front mid panel 616 open, according to an illustrative embodiment of the invention. With reference to FIGS. 19A-19C, the system 100 is structured as a single use disposable module 634 (shown and described in detail below with reference to FIGS. 24A-25C) and a multiple use module 650 (shown without the single use module in FIG. 20). As discussed in further detail below, according to one feature of the illustrative embodiment, all of the blood contacting components of the system 100 are included in the single use disposable module 634 so that after a use, the entire single use module 634 may be discarded, a new module 634 installed, and the system 100 available for use again within a very brief amount of time.

[0163] According to the illustrative embodiment, the single use module 634 includes a chassis 635 for supporting all of the components of the single use module 634. As described in more detail with regard to FIGS. 24A-25C, the components of the single use module 634 include the organ chamber assembly 104, described above in detail with respect to FIGS. 5A-5F, the perfusion fluid reservoir 160, the oxygenator 114, the perfusion fluid pump interface 300, and all of the various fluid flow conduits and peripheral monitoring components 633.

[0164] As shown in FIGS. 19A-20A, with the top 614 removed and the front panel 616 open, an operator has easy access to many of the components of the disposable 634 and multiple use 650 modules. For example, the operator may install, remove and view the levels of the nutrient 116 and preservative 118 supplies of the nutritional subsystem 115. The operator may also control operation of the nutrient 116 and preservative 118 infusion pump 182. The operator may also cannulate an organ, such as the heart 102, into the organ chamber assembly 104. As described in detail below with reference to FIGS. 21A-21C, this configuration also provides the operator with sufficient access to install and/or remove the single use module 634 to/from the multiple use module 650.

[0165] FIG. 20A shows a front perspective view of the multiple use module 650 with the single use module 634 removed. As shown, the multiple use module 650 includes: the cart 604; the lower section 602b of the housing 602, along with all of the components externally mounted to it, along with those contained therein (described in further detail below, with reference to FIGS. 21A-21C and 23A-23C); the upper section 602a of the housing 602 and all of the components externally mounted to it, including the top cover 614, the handles 610, 612a, and 612b, and the front panel 616; the operator interface module 146; and the perfusion fluid pump motor assembly 106. As described in detail below with reference to FIGS. 21A-21C, the multiple use module 650 also includes a bracket assembly 638 for receiving and locking into place the single use module 634.

[0166] As shown in FIG. 20A and described in further detail below with reference to FIGS. 22A-22C, the multiple

use module 650 also includes a front-end interface circuit board 636 for interfacing with a front-end circuit board (shown in FIG. 24D at 637) of the disposable module 634. As also described in detail with reference to FIGS. 22A-22C, power and drive signal connections between the multiple use module 650 and the disposable module 634 are made by way of corresponding electromechanical connectors 640 and 647 on the front end interface circuit board 636 and the front end circuit board 637, respectively. By way of example, the front-end circuit board 637 receives power for the disposable module 634 from the front-end interface circuit board 636 via the electromechanical connectors 640 and 647. The front end circuit board 637 also receives drive signals for various components (e.g., the heater assembly 110, and the oxygenator 114) from the controller 150 via the front-end interface circuit board 636 and the electromechanical connectors 640 and 647. The front-end circuit board 637 and the front-end interface circuit board 636 exchange control and data signals (e.g., between the controller 150 and the disposable module 134) by way of optical connectors (shown in FIG. 22B at 648). As described in more detail with reference to FIGS. 22A-22F, the connector configuration employed between the front-end 637 and front-end interface 636 circuit boards ensures that critical power and data interconnections between the single and multiple use modules 634 and 650, respectively, continue to operate even during transport over rough terrain, such as may be experienced during organ transport.

[0167] As shown in FIG. 20A, according to another feature, the upper section 602a of the housing 602 includes a fluid tight basin 652, which is configured to capture any perfusion fluid 108 and/or nutritional 116 and/or preservative 118 solution that may inadvertently leak. The basin 652 also prevents any leaked fluid 108 or solution 116/118 from passing into the lower section 602b of the housing 602. In this way, the basin 652 shields the electronic components of the system 100 from any such leaked fluid 108 or solution 116/118. Shielded components include, for example, the power board 720 shown in and discussed in further detail below with reference to FIGS. 23C and 23D. The basin 652 includes a section 658, which extends over and shields the perfusion fluid pump 106 from any inadvertently leaked fluid. According to another feature, the basin 652 is sized to accommodate the entire volume of perfusion fluid 108 (including the maintenance solutions 116/118) contained within the system 100 at any particular time.

[0168] Referring also to FIG. 20B, according to a further feature of the illustrative embodiment, an outer side 659 of the pump covering portion 658 of the basin 652 includes a slot 660. As described in further detail below with reference to FIGS. 21A-21C and 24A, the slot 660 engages with a projection 662 on the single use module 634 during installation of the single use module 634 into the multiple use module 650.

[0169] Turning now to the installation of the single use module 634 into the multiple use module 650, FIG. 21A shows a detailed view of the above-mentioned bracket assembly 638 located on the multiple use module 650 for receiving and locking into place the single use module 634. FIG. 21B shows a side perspective view of the single use module 634 being installed onto the bracket assembly 638 and into the multiple use module 650, and FIG. 21C shows a side view of the single use module 634 installed within the multiple use module 650. With reference to FIGS. 21A and

21B, the bracket assembly 638 includes two mounting brackets 642a and 642b, which mount to an internal side of a back panel 654 of the upper housing section 602a via mounting holes 644a-644d and 646a-646d, respectively. A cross bar 641 extends between and rotatably attaches to the mounting brackets 642a and 642b. Locking arms 643 and 645 are spaced apart along and radially extend from the cross bar 641. Each locking arm 643 and 645 includes a respective downward extending locking projection 643a and 645b. A lever 639 attaches to and extends radially upward from the cross bar 641. Actuating the lever 639 in the direction of the arrow 651 rotates the locking arms 643 and 645 toward the back 606b of the housing 602. Actuating the lever 639 in the direction of the arrow 653 rotates the locking arms 643 and 645 toward the front 606a of the housing 602.

[0170] As described above with respect to FIG. 10, the perfusion pump interface assembly 300 includes four projecting heat staking points 321a-321d. As shown in FIG. 24A, during assembly, the projections 321a-321d are aligned with corresponding apertures 657a-657d and heat staked through the apertures 657a-657d into the projections 321a-321d to rigidly mount the outer side 304 of the pump interface assembly 300 onto the C-shaped bracket 656 of the single use module chassis 635.

[0171] With reference to FIGS. 10, 20B, 21A, 21B and 24A, during installation, in a first step, the single use module 634 is lowered into the multiple use module 650 while tilting the single use module 634 forward (shown in FIG. 21B). This process slides the projection 662 of FIG. 24A into the slot 660 of FIG. 20B. As shown in FIG. 10, it also positions the flange 328 of the pump interface assembly 300 within the docking port 342 of the perfusion pump assembly 106, and the tapered projections 323a and 323b of the pump interface assembly 300 on the clockwise side of corresponding ones of the features 344a and 344b of the pump assembly bracket 346. In a second step, the single use module 634 is rotated backwards until locking arm cradles 672 and 674 of the single use module chassis 635 engage projections 643 and 645 of spring-loaded locking arm 638, forcing the projections 643 and 645 to rotate upward (direction 651), until locking projections 643a and 645a clear the height of the locking arm cradles 672 and 674, at which point the springs cause the locking arm 638 to rotate downward (direction 653), allowing locking projections 643a and 645a to releasably lock with locking arm cradles 672 and 674 of the disposable module chassis 635. This motion causes the curved surface of 668 of the disposable module chassis projection 662 of FIG. 24A to rotate and engage with a flat side 670 of the basin slot 660 of FIG. 20B. Lever 639 can be used to rotate the locking arm 638 upwards (direction 651) to release the single use module 635.

[0172] As shown in FIG. 10, this motion also causes the pump interface assembly 300 to rotate in a counterclockwise direction relative to the pump assembly 106 to slide the flange 328 into the slot 332 of the docking port 342, and at the same time, to slide the tapered projections 323a and 323b under the respective bracket features 344a and 344b. As the tapered projections 323a and 323b slide under the respective bracket features 344a and 344b, the inner surfaces of the bracket features 344a and 344b engage with the tapered outer surfaces of the tapered projections 323a and 323b to draw the inner side 306 of the pump interface assembly 300 toward the pump driver 334 to form the fluid

tight seal between the pump interface assembly 300 and the pump assembly 106. The lever 639 may lock in place to hold the disposable module 634 securely within the multiple use module 650.

[0173] As mentioned briefly above with reference to FIG. 20A, interlocking the single use module 374 into the multiple use module 650 forms both electrical and optical interconnections between the front end interface circuit board 636 on the multiple use module 650 and the front end circuit board 637 on the single use module 634. The electrical and optical connections enable the multiple use module 650 to power, control and collect information from the single module 634. FIG. 22A is a conceptual drawing showing various optical couplers and electromechanical connectors on the front end circuit board 637 of the single-use disposable module 634 used to communicate with corresponding optical couplers and electromechanical connectors on the front end interface circuit board 636 of the multiple use module 650. Since this correspondence is one for one, the various optical couplers and electromechanical connectors are described only with reference to the front end circuit board 637, rather than also depicting the front end circuit board 650.

[0174] According to the illustrative embodiment, the front end circuit board 637 receives signals from the front end interface circuit board 636 via both optical couplers and electromechanical connectors. For example, the front end circuit board 637 receives power 358 (also shown in FIG. 14) from the front end interface circuit board 636 via the electromechanical connectors 712 and 714. The front end circuit board 637 the power to the components of the single use module 634, such as the various sensors and transducers of the single use module 634.

[0175] Optionally, the front end circuit board 637 converts the power to suitable levels prior to distribution. The front end interface circuit board 636 also provides the heater drive signals 281a and 281b of FIG. 13 to the applicable connections 282a on the heater 246 of FIG. 6E via the electromechanical connectors 704 and 706. Similarly, the electromechanical connectors 708 and 710 couple the heater drive signals 283a and 283b of FIG. 13 to the applicable connections in 282b of the heater 248. The front-end circuit board 637 may receive a defibrillation command from the front end interface circuit board 636 via the electromechanical connector 687. In response, the front end circuit board 637 generates the defibrillation signal 143 having suitable current and voltage levels, and as shown in FIG. 5E, couples the signal 143 to the organ chamber assembly 104 via the electrical interface connections 235a-235b.

[0176] In another illustrative embodiment, the defibrillation command can be provided from an external source (not shown), rather than through the circuit board 636. As an example, and with reference to FIG. 5E and FIG. 1, an external defibrillation device can be plugged into the electrical coupler 613 shown in FIG. 24E, which is connected to the electrical interface connections 235a-235b. The external defibrillation device sends a defibrillation signal 143 through the coupler 613 and the interface connections 235a and 235b to electrodes 142 and 144. The electrodes 142 and 144 then deliver the signal 143 to the heart 102. This alternative embodiment allows the user to provide defibrillation (and pacing) without passing the signal 143 through the circuit

boards 618, 636, and 637. An exemplary external defibrillation device may include the Zoll M-Series Portable Defibrillator.

[0177] According to the illustrative embodiment, the front end circuit board 637 receives signals from temperature, pressure, fluid flow-rate, oxygenation/hematocrit and ECG sensors, amplifies the signals, converts the signals to a digital format and provides them to the front-end interface circuit board 636 by way of optical couplers. For example, the front end circuit board 637 provides the temperature signal 121 from the sensor 120 on the heater plate 250 (shown in FIGS. 6A and 13) to the front end interface circuit board 636 by way of the optical coupler 676. Similarly, the front end circuit board 637 provides the temperature signal 123 from the sensor 122 on the heater plate 252 (shown in FIGS. 6A and 13) to the front end interface circuit board 636 by way of the optical coupler 678. The front end circuit board 637 also provides the perfusion fluid temperature signals 125 and 127 from the thermistor sensor 124 (shown in FIGS. 6A and 13) to the front end interface circuit board 636 via respective optical couplers 680 and 682. Perfusion fluid pressure signals 129, 131 and 133 are provided from respective pressure transducers 126, 128 and 130 to the front end interface circuit board 636 via respective optical couplers 688, 690 and 692. The front end circuit board 637 also provides perfusion fluid flow rate signals 135, 137 and 139 from respective flow rate sensors 134, 136 and 138 to the front end interface circuit board 636 by way of respective optical couplers 694, 696 and 698. Additionally, the front end circuit board 637 provides the oxygen saturation 141 and hematocrit 145 signals from the oxygen saturation sensor 140 to the front end interface circuit board 636 by way of respective optical couplers 700 and 702.

[0178] In other illustrative embodiments, one or more of the foregoing sensors are wired directly to the main system board 718 (described below with reference to FIG. 23D) for processing and analysis, thus by-passing the front-end interface board 636 and front-end board 637 altogether. Such embodiments may be desirable where the user prefers to re-use one or more of the sensors prior to disposal. In one such example, the flow rate sensors 134, 136 and 138 and the oxygen and hematocrit sensor 140 are electrically coupled directly to the system main board 718 through electrical coupler 611 shown in FIG. 23C, thus by-passing any connection with the circuit boards 636 and 637.

[0179] As described above with respect to FIGS. 11-16, the controller 150 employs the signals provided to the front end interface circuit board 636, along with other signals, to transmit data and otherwise control operation of the system 100. As described with respect to FIGS. 17A-17i, the controller 150 also displays sensor information, and may display to the operator various alarms relating to the sensor information by way of the operator interface module 146.

[0180] FIG. 22B illustrates the operation of an exemplary electromechanical connector pair of the type employed for the electrical interconnections between the circuit boards 636 and 637. Similarly, FIG. 22C illustrates the operation of an optical coupler pair of the type employed for the optically coupled interconnections between the circuit boards 636 and 637. One advantage of both the electrical connectors and optical couplers employed is that they ensure connection integrity, even when the system 100 is being transported over rough terrain, for example, such as being wheeled along a tarmac at an airport, being transported in an aircraft

during bad weather conditions, or being transported in an ambulance over rough roadways. Additionally, the optical couplers electrically isolate the temperature, pressure and ECG sensors from the rest of the system 100, which prevents a defibrillation signal from damaging the system 100. The power for the front end board 637 is isolated in a DC power supply located on the front end interface board 636.

[0181] As shown in FIG. 22B, the electromechanical connectors, such as the connector 704, include a portion, such as the portion 703, located on the front end interface circuit board 636 and a portion, such as the portion 705, located on the front end circuit board 637. The portion 703 includes an enlarged head 703a mounted on a substantially straight and rigid stem 703b. The head 703 includes an outwardly facing substantially flat surface 708. The portion 705 includes a substantially straight and rigid pin 705 including an end 705a for contacting the surface 708 and a spring-loaded end 705b. Pin 705 can move axially in and out as shown by the directional arrow 721 while still maintaining electrical contact with the surface 708 of the enlarged head 703a. This feature enables the single use module 634 to maintain electrical contact with the multiple use module 650 even when experiencing mechanical disturbances associated with transport over rough terrain. An advantage of the flat surface 708 is that it allows for easy cleaning of the interior surface of the multiple use module 650. According to the illustrative embodiment, the system 100 employs a connector for the electrical interconnection between the single use disposable 634 and multiple use 650 modules. An exemplary connector is part no. 101342 made by Interconnect Devices. However, any suitable connector may be used.

[0182] Optical couplers, such as the optical couplers 684 and 687 of the front end circuit board 637, are used and include corresponding counterparts, such as the optical couplers 683 and 685 of the front end interface circuit board 636. The optical transmitters and optical receiver portions of the optical couplers may be located on either circuit board 636 or 637. For example, in the case of the ECG signal 379, the optical transmitter 684 is located on the circuit board 637 for receiving the electrical signal 379 and optically coupling it to the optical receiver 683 on the circuit board 636. In the case where the defibrillator signal is transmitted through the circuit boards 636 and 637 (rather than directly to the main board 718), the optical transmitter 685 on the circuit board 636 optically couples the signal to the optical receiver 687 on the circuit board 637.

[0183] As in the case of the electromechanical connectors employed, allowable tolerance in the optical alignment between the optical transmitters and corresponding optical receivers enables the circuit boards 636 and 637 to remain in optical communication even during transport over rough terrain. According to the illustrative embodiment, the system 100 uses optical couplers made under part nos. SFH485P and/or SFH203PFA by Osram. However, any suitable coupler may be used.

[0184] The couplers and connectors facilitate the transmission of data within the system 100. The front-end interface circuit board 636 and the front-end board 637 transmit data pertaining to the system 100 in a paced fashion. As shown in FIG. 22C, circuit board 636 transmits to the front-end board 637 a clock signal that is synchronized to the clock on the controller 150. The front-end circuit board 637 receives this clock signal and uses it to synchronize its transmission of system data (such as temperatures, pres-

tures, ECG, r-wave detection, or other desired information) with the clock cycle of the controller 150. This data is digitized by a processor on the front-end circuit board 637 according to the clock signal and a pre-set sequence of data type and source address (i.e. type and location of the sensor providing the data). The front-end interface circuit board 636 receives the data from the front-end board 637 and transmits the data set to the main board 618 for use by the controller 150 in evaluation, display, and system control, as described above with reference to FIGS. 11, 12 and 14. Additional optical couplers can be added between the multiple use module and single use module for transmission of control data from the multiple use module to the single use module, such data including heater control signals or pump control signals.

[0185] Having described the mechanical, electrical and optical interconnections between the single use module 634 and the multiple use module 650, additional components of the multiple use module 650 will now be discussed with respect to FIGS. 23A-23D, followed by a description of the mechanical arrangement of the components of the single use module 634 with respect to FIGS. 24A-28C. As shown in FIGS. 23A-23D, with the walls of the housing 602 removed, in addition to those components previously discussed, the multiple use module 650 includes an on-board gas supply 172, located in the lower section 602b of the housing 602. The gas supply 172 is depicted in FIGS. 23A-23D as a tank, positioned within the gas tank bay 630 by a support structure 712, which abuts the tank 172. Optionally, the gas supply 172 may be further secured within the gas tank bay 630 by a strap and buckle assembly 714 or other suitable mechanism. With particular reference to FIG. 23B and as described above with reference to FIG. 1, the gas supply 172 provides gas to the system 100 through the gas regulator 174 and the gas flow chamber 176. The gas pressure sensor 132 measures the gas pressure in the gas supply 172, and the gas pressure gauge 178 provides a visual indication of the fullness of the gas supply 172. Additionally, an electrical connection between the controller 150 and the gas flow chamber 176 enables the controller 150 to regulate automatically the gas flow into the oxygenator 114.

[0186] As shown most clearly in FIG. 23C, the battery bay 628 houses the batteries 352a-352c. As noted above with reference to FIG. 14, a lock-out mechanism is used to prevent more than one of the batteries 352a-352c from being removed from the battery bay 628 at a given time while the system 100 is operating.

[0187] As discussed above, the system 100 includes a plurality of interconnected circuit boards for facilitating power distribution and data transmission to, from and within the system 100. Particularly, as discussed above with reference to FIGS. 22A-22E and as shown in FIG. 23C, the multiple use module 650 includes a front end interface circuit board 636, which optically and electromechanically couples to the front end circuit board 637 of the single use module 650. As also shown in FIG. 23C, the system 100 further includes a main board 718, a power circuit board 720, and a battery interface board 711 located on the multiple use module 650. The main board 718 is configured to allow the system 100 to be fault tolerant, in that if a fault arises in the operation of a given circuit board (as shown in FIG. 23D), the main board 718 saves pumping and heating

parameters in non-volatile memory. When the system 100 reboots, it can re-capture and continue to perform according to such parameters.

[0188] Referring to the conceptual drawing of FIG. 23D, cabling 731 brings power (such as AC power 351) from a power source 350 to the power circuit board 720 by way of connectors. 744 and 730. The power supply 350 converts the AC power to DC power and distributes the DC power as described above with reference to the power subsystem of FIG. 14. Referring also to FIGS. 14 and 22A, the power circuit board 720 couples DC power and a data signal 358 via respective cables 727 and 729 from the connectors 726 and 728 to corresponding connectors 713 and 715 on the front end interface circuit board 636. Cable 729 carries both power and a data signal to the front end interface board 636. Cable 727 carries power to the heater 110 via the front-end interface board 636. The connectors 713 and 715 interfit with corresponding connectors 712 and 714 (described above with respect to FIG. 22A) on the front end circuit board 637 on the single use module 634 to provide power to the single use module 634.

[0189] As shown in FIG. 23D, the power circuit board 720 also provides DC power 358 and a data signal from the connectors 732 and 734, respectively, on the power circuit board 720 to corresponding connectors 736 and 738 on the main circuit board 718 by way of the cables 733 and 735. Referring also to FIGS. 14 and 19A, the cable 737 couples DC power 358 and a data signal from a connector 740 on the main circuit board 718 to the operator interface module 146 by way of a connector 742 on the operator interface module cradle 623. The power circuit board 720 also provides DC power 358 and a data signal from connectors 745 and 747 via cables 741 and 743 to connectors 749 and 751 on a battery interface board 711. Cable 741 carries the DC power signal and cable 743 carries the data signal. Battery interface board 711 distributes DC power and data to batteries 352a, 352b and 352c. Batteries 352a, 352b and 352c contain electronic circuits that allow them to communicate with each other to monitor the respective charges, as described above in reference to FIG. 14, so that the controller 150 can monitor and control the charging and discharging of the batteries 352a-352c.

[0190] According to some illustrative embodiments, the controller 150 is located on the main circuit board 718 and performs all control and processing required by the system 100. However, in other illustrative embodiments, the controller 150 is distributed, locating some processing functionality on the front end interface circuit board 636, some on the power circuit board 720, and/or some in the operator interface module 146. Suitable cabling is provided between the various circuit boards, depending on whether and the degree to which the controller 150 is distributed within the system 100.

[0191] As described above with reference to FIGS. 19A-19C and 23A-23C, the system 100 mechanically divides into the single use disposable module 634 and the multiple use module 650. As also described above, according to the illustrative embodiment, the single use module 634 includes all or substantially all of the perfusion fluid 108 contacting elements/assemblies of the system 100, along with various peripheral components, flow conduits, sensors and support electronics for operating the blood contacting components. As discussed above with reference to FIGS. 22A and 23D, according to the illustrative embodiment, the module 634

does not include a processor, instead relying on the controller 150, which may, for example, be distributed between the front end interface circuit board 636, the power circuit board 720, the operator interface module 146, and the main circuit board 718, for control. However, in other illustrative embodiments, the single use module 634 may include its own controller/processor, for example, on the front end circuit board 637.

[0192] Referring to FIGS. 24A-28C, the single use module 634 will next be described in terms of the components included therein. After that, exemplary forward and retrograde flow modes are traced through the described components.

[0193] Referring first to FIG. 24A, the disposable module 634 includes a chassis 635 having upper 750a and lower 750b sections. The upper section 750a includes a platform 752 for supporting various components. The lower section 750b supports the platform 752 and includes structures for pivotably connecting with the multiple use module 650. More particularly, the lower chassis section 750b includes the C-shaped mount 656 for rigidly mounting the perfusion fluid pump interface assembly 300, and the projection 662 for sliding into and snap fitting with the slot 660 of FIG. 20B. The lower chassis section 750b also provides structures for mounting the oxygenator 114. As shown in FIGS. 25A and 25C, the lower section 750b further includes structures for mounting the heater assembly 110. Additionally, the reservoir 160 mounts to the underside of the platform 725 and extends into the lower chassis section 750b. Various sensors, such as the O₂ saturation and hematocrit sensor 140 (shown in FIG. 24A and described in detail below with reference to FIGS. 28A-28C), the flow rate sensor 136 (shown in FIG. 24A), the flow rate sensor 138 (shown in FIG. 25B), are located within and/or mount to the lower chassis section 750b. The flow pressure compliance chamber 188 (shown in FIG. 25B) is also located in the lower chassis section 750b. As shown in FIG. 24D, the lower chassis section 750b also mounts the front end circuit board 637. Conduits located in the lower chassis section 750b are described in further detail below with reference to the normal and retrograde flow paths through the single use module 634.

[0194] Referring to FIGS. 24A-25C, and as mentioned above, the upper chassis section 750a includes the platform 752. The platform 752 includes handles 752a and 752b formed therein to assist in installing and removing the single use module 634 from the multiple use module 650. Alternatively, such handles can be located on the platform 757 to allow for easier accessibility during installation of the single use module into the multiple use module. As shown most clearly in FIG. 24C, an angled platform 757 mounts onto the platform 752. The organ chamber assembly 104 mounts to the angled platform 757. According to the illustrative embodiment, with the single use module 634 installed within the multiple use module 650, the platform 757 is angled at about 10° to about 80° relative to horizontal, to provide an optimal angle of operation for the heart 102 when placed within the organ chamber assembly 104. In some illustrative embodiments, the platform 757 is angled at about 20° to about 60°, or about 30° to about 50° relative to horizontal. The flow mode selector valve 112, the flow rate sensor 134, and the perfusion fluid flow pressure compliance chambers 184 and 186 also mount onto the angled platform 757.

[0195] Referring to FIG. 24E, several fluid ports mount to the platform 752. For example, a fluid sampling port 754 enables an operator to sample the flow into and/or out of the aorta 158 via the cannulation interface 162 on the organ chamber assembly 104. A fluid sampling port 755 enables the operator to sample the flow into the left atrium 152 via the interface 170 on the organ chamber assembly 104. Additionally, a fluid port 758 enables the operator to sample the coronary flow out of the pulmonary artery 164 via the pulmonary artery interface 166 on the organ chamber 104. According to the illustrative embodiment, the operator turns the a respective valve 754a, 755a or 758a to obtain flow from the sampling ports 754, 755 and 758. Flow from the particular port selected is provided at a single common outlet 764. According to one feature, only flow from the left most port selected is provided at the outlet 764. By way of example, if the operator opens both ports 755 and 758, only flow from port 755 is provided at the outlet 764. In this way, system 100 reduces the likelihood of an operator mixing samples from multiple ports.

[0196] The single use module 634 also includes a general injection port 762, operable with the valve 762a, for enabling the operator to inject medication into the perfusion fluid 108, for example, via the reservoir 160. Both the sampling 764 and injection 762 ports mount to the platform 752. Also located on the upper chassis section 750a is an infusion port 766, operable with the valve 766a, for flowing the nutritional 116 and preservative 118 fluids into the perfusion fluid 108. The upper chassis section 750a also includes a tube 774 for loading the exsanguinated blood from the donor into the reservoir 160. As shown in FIG. 24D, the single use module 634 also includes non-vented caps 776 for replacing vented caps on selected fluid ports that are used while running a sterilization gas through the single use module 634 during sterilization. Preferably, such sterilization takes place prior to packaging the single use module 634 for sale.

[0197] The upper chassis section 750a also includes the flow clamp 190 for regulating back pressure applied to the left atrium 152 when the heart 102 is cannulated and operating in normal flow mode in the organ chamber assembly 104. The upper chassis section 750a further includes a trickle valve 768. The trickle valve 768 may be opened and closed with the handle 768a to regulate a small fluid flow to the left atrium 152 to moisten the left atrium 152 during retrograde flow mode. The upper chassis section 750a also includes ports 770 for infusion of additional solutions and 772 for purging the oxygenator 114, operable with respective valves 770a and 772a.

[0198] As shown most clearly in FIGS. 24A and 24D, the upper chassis section 750 further includes the flow pressure probes 126, 128 and 130. As described above with reference to FIG. 1, the probe 126 measures the pressure of the perfusion fluid 108 flowing into/out of the aorta 158. The probe 128 measures the pressure of the perfusion fluid 108 flowing into the left atrium 152 through the pulmonary vein 168. The probe 130 measures the pressure of the perfusion fluid 108 flowing out of the pulmonary artery 164. Each probe includes a respective connector 126a, 128a and 130a (shown shortened for clarity) for coupling a respective signal 129, 131, and 133 to the front end circuit board 637.

[0199] Referring particularly to the single use module 654 cross-sectional side view of FIG. 24C, the reservoir 160 includes several components. More specifically, the reser-

voir 160 includes four inlets: 782, 784, 786 and 788. The inlet 782 transfers perfusion fluid 108 from the drain 201 of the organ chamber 194 into the reservoir 160. The inlet 784 receives exsanguinated blood from the tube 774. The inlet 786 receives oxygenated perfusion fluid 108 from the oxygenator 114, and the inlet 788 receives perfusion fluid 108 out of the aorta 158 via the back pressure clamp 190. The reservoir 160 also has an outlet 790, which provides the perfusion fluid to the one way inlet valve 191. The reservoir 160 further includes a defoamer 778 and a filter 780. The defoamer 778 removes bubbles out of the perfusion fluid 108 as it enters the reservoir 160. According to the illustrative embodiment, the defoamer is made of porous polyurethane foam with an antifoam coating. The filter 780 is a polyester felt, which filters debris, blood particles, emboli, and air bubbles out of the perfusion fluid as it enters the reservoir 160.

[0200] As mentioned above in the summary, the O₂ saturation and hematocrit sensor 140 employed in the single use module 634 includes important advantages over prior art approaches. FIGS. 28A-28C depict an illustrative embodiment of the O₂ saturation and hematocrit sensor 140 of the invention. As shown in FIG. 28A, the sensor 140 includes an in-line cuvette shaped section of tube 812 connected to the conduit 798, which has at least one optically clear window through which an infrared sensor can provide infrared light. Exemplary sensors used in the in-line cuvette-shaped tube 812 are those made by Datamed, BLOP4. As shown in the cross-sectional view of FIG. 28B, the cuvette 812 is a one-piece molded part having connectors 801a and 801b. The connectors 801a and 801b are configured to adjoin to connecting receptacles 803a and 803b, respectively, of conduit ends 798a and 798b. This interconnection between cuvette 812 and conduit ends 798a and 798b is configured so as to provide a substantially constant cross-sectional flow area inside conduit 798 and cuvette 812. The configuration thereby reduces, and in some embodiments substantially removes, discontinuities at the interfaces 814a and 814b between the cuvette 812 and the conduit 798. Reduction/removal of the discontinuities enables the blood based perfusion fluid 108 to flow through the cuvette with reduced lysing of red blood cells and reduced turbulence, which enables a more accurate reading of perfusion fluid oxygen levels. This also reduces damage to the perfusion fluid 108 by the system 100, which ultimately reduces damage done to the heart 102 while being perfused by the system 100.

[0201] According to the illustrative embodiment, the cuvette 812 is formed from a light transmissive material, such as any suitable light transmissive glass or polymer. As shown in FIG. 28A, the sensor 140 also includes an optical transceiver 816 for directing light waves at perfusion fluid 108 passing through the cuvette 812 and for measuring light transmission and/or light reflectance to determine the amount of oxygen in the perfusion fluid 108. As illustrated in FIG. 28C, in some embodiments a light transmitter is located on one side of the cuvette 812 and a detector for measuring light transmission through the perfusion fluid 108 is located on an opposite side of the cuvette 812. FIG. 28C depicts a top cross-sectional view of the cuvette 812 and the transceiver 816. The transceiver 816 fits around cuvette 812 such that transceiver interior flat surfaces 811 and 813 mate against cuvette flat surfaces 821 and 823, respectively, while the interior convex surface 815 of transceiver 816 mates with the cuvette 812 convex surface 819. In operation, when

uv light is transmitted from the transceiver 816, it travels from flat surface 811 through the fluid 108 inside cuvette 812, and is received by flat surface 813. The flat surface 813 may be configured with a detector for measuring the light transmission through the fluid 108.

[0202] The fluid flow path through the single use module 634 in both normal and retrograde flow modes will now be described with reference to FIGS. 24A-24D and FIG. 25A. As described above with reference to FIGS. 1-4, the system 100 can maintain the heart 102 in two modes of operation; a normal flow mode, shown in FIG. 3, and a retrograde flow mode shown in FIG. 4. As mentioned above with regard to FIG. 1, to change between normal and retrograde flow modes, the system 100 provides the flow mode selector valve 112, shown in detail in FIGS. 26A and 26B. To operate in normal flow mode, the operator sets the flow mode selector valve handle 112e to the position indicated in FIG. 24A. This has the effect of aligning the flow paths through the selector valve 112 as shown in FIG. 26A. Specifically, in normal flow mode, fluid can flow into port 112b, through the flow channel 112f and out the port 112c. Additionally, fluid can flow into port 112d, through the flow channel 112g and out the port 112a. To operate in retrograde flow mode, the operator sets the flow mode selector valve handle 112e to the position indicated in FIG. 24B. This has the effect of aligning the flow paths through the selector valve 112 as shown in FIG. 26B. Specifically, in retrograde flow mode, fluid can flow into port 112b, through the flow channel 112h and out the port 112d.

[0203] Referring to FIG. 24A, in normal flow mode, the reservoir 160 provides the perfusion fluid 108 to the one way inlet valve 191 of the perfusion pump interface assembly 300. Referring to FIG. 25A, the perfusion pump 106 pumps the perfusion fluid 108 out the outlet valve 310. Referring to FIG. 25C, the perfusion fluid 108 then flows through the conduit 792 and the compliance chamber 188 and into the inlet 110a of the heater assembly 110. The heater assembly 110 heats the perfusion fluid 108 and then flows it out the heater outlet 110b. Referring to FIG. 24A, the heated perfusion fluid 108 flows from the heater outlet 110b in the lower chassis section 750b through the chassis plate 752 and into the port 112b of the mode select valve 112 via the conduit 794. Referring also to FIG. 24D, the perfusion fluid 108 flows out the mode valve port 112c, through the compliance chamber 186, the conduit 796, and the pressure sensor 128 into the pulmonary vein cannulation interface 170 on the organ chamber assembly 104.

[0204] Referring to FIG. 24A, in normal flow mode, the heart 102 pumps the perfusion fluid 108 out the pulmonary artery 164 through the pulmonary artery interface 166 and the pressure sensor 130. The conduit 796 then flows the perfusion fluid 108 from the pulmonary artery interface 166 through the plate 752 and through the O₂ saturation and hematocrit sensor 140. Referring also to FIGS. 25A and 25C, the conduit 798 then flows the perfusion fluid 108 from the sensor 140 through the flow-rate sensor 136 into the oxygenator 114. The conduit 800 flows the perfusion fluid 108 from the oxygenator 114 back into the reservoir 160 by way of the reservoir inlet 786.

[0205] Referring to FIGS. 24A, 24D and 24E, in normal flow mode, the heart 102 also pumps the perfusion fluid 108 out of the aorta 158 through the aorta interface 162 and the pressure sensor 126. The conduit 802 flows the perfusion fluid 108 from the pressure sensor 126 through the flow rate

sensor 134 and back into the port 112d on the flow mode selector valve 112. A clamp 804 holds the conduit 802 in place. A conduit 806 flows the perfusion fluid 108 out the port 112a from the flow mode selector valve 112 through the compliance chamber 184 and the back pressure adjustment clamp 190. As mentioned above, the clamp 190 may be adjusted to restrict flow through the conduit 806 to adjust the back pressure seen by the aorta 158 during normal flow mode to more realistically simulate normal physiologic conditions. The compliance chamber 184, which can expand and contract as perfusion fluid 108 is pumped into and out of it, interoperates with the clamp 190 to dampen flow pressure spikes to further improve simulation of near-normal physiologic conditions. The after-load clamp 190 is configured to closely emulate systemic vascular resistance of the human body which affects aortic pressure, left atrial pressure, and coronary flow. A conduit 808 returns the perfusion fluid 108 into the reservoir 160 by way of the reservoir inlet 788.

[0206] In retrograde flow mode, the flow mode selector valve 112 is positioned as shown in FIG. 24B. Referring to FIG. 24B, the reservoir 160 provides the perfusion fluid 108 to the inlet valve 191. As shown in FIG. 25A, the perfusion pump 106 pumps the perfusion fluid 108 out the outlet valve 310. As shown in FIG. 25C, the perfusion fluid 108 then flows through the conduit 792 and the compliance chamber 188 and into the inlet 110a of the heater assembly 110. The heater assembly 110 heats the perfusion fluid 108 and then flows it out the heater outlet 110b. Referring to FIG. 24B, the heated perfusion fluid 108 flows from the heater outlet 110b in the lower chassis section 750b through the chassis plate 752 and into the input 112b of the mode select valve 112 via the conduit 794. Referring also to FIG. 24D, the perfusion fluid 108 flows out the mode valve outlet 112d, into the conduit 802, through the flow rate sensor 134, the pressure sensor 126 and into the aorta 158 via the aorta interface 162. The perfusion fluid 108 then flows through the coronary sinus 155 and the rest of the coronary vasculature.

[0207] Referring to FIG. 24B, in retrograde flow mode, the heart 102 pumps the perfusion fluid 108 out of the pulmonary artery 164 and through the pulmonary artery interface 166 and the pressure sensor 130. The conduit 796 then flows the perfusion fluid from the pulmonary artery interface 166 through the plate 752 and into the O₂ saturation and hematocrit sensor 140. Referring also to FIGS. 25A and 25C, the conduit 798 then flows the perfusion fluid 108 from the sensor 140 through the flow rate sensor 136 into the oxygenator 114. The conduit 800 flows the perfusion fluid 108 from the oxygenator 114 back into the reservoir 160 by way of the reservoir inlet 786. In retrograde flow mode, substantially no perfusion fluid is pumped into or out of the left atrium 152 via the pulmonary vein 168 and the pulmonary vein interface 170, with the exception of a small amount of perfusion fluid diverted by the trickle valve 768 from the conduit 794 around the flow mode selector valve 112 into the compliance chamber 186. As mentioned above, the trickle flow provides sufficient perfusion fluid 108 to keep the left atrium 152 moistened during retrograde flow.

[0208] As described above, the illustrative embodiment of the system 100 has one or more sensors or probes for measuring fluid flow and pressure. The probes and/or sensors may be obtained from standard commercial sources. The flow rate sensors 134, 136 and 138 are conventional, ultrasonic flow sensors, such as those available from Tran-

sonic Systems Inc., Ithaca, N.Y. The fluid pressure probes 126, 128 and 130 may be conventional, strain gauge pressure sensors available from MSI or G.E. Thermometrics. Alternatively, a pre-calibrated pressure transducer chip can be embedded into organ chamber connectors and wired to a data collection site such as the front end board 637.

[0209] Having described the electrical and mechanical components and functionality of illustrative embodiments of the system 100 and certain modes of operation thereof, the system 100 will next be described with reference to the illustrative organ harvest and transplant procedures of FIGS. 29A and 29B. More particularly, FIG. 29A is a flow diagram 900 depicting exemplary methodologies for harvesting the donor heart 102 and cannulating it into the system 100 at a donor location. FIG. 29B depicts particular points of care for handling the heart 102 in preparation for cannulation, and FIG. 30 is a flow diagram 902 of exemplary methodologies for removing the donor organ 102 from the system 100 and transplanting it into a patient at a recipient site.

[0210] As shown in FIG. 29A, the process of obtaining and preparing the heart 102 for cannulation and transport begins by providing a suitable organ donor 904. The organ donor is brought to a donor location, whereupon the process of receiving and preparing the donor heart 102 for cannulation and transport proceeds down two intersecting pathways 906 and 908. The pathway 906 principally involves preparing the donor heart 102 for transplant, while the pathway 908 principally involves preparing the system 100 to receive the donor heart 102 and then transporting the heart 102 via system 100 to the recipient site.

[0211] With particular reference to FIG. 29A, the first pathway 906 includes exsanguinating the donor 910, arresting the donor heart 914, explaining the heart 916, and preparing the heart 102 for cannulation 918 into the system 100. In particular, in the exsanguination step 910, the donor's blood is removed and set aside so it can be used to perfuse the heart 102 during preservation on the system 100. This step is performed by inserting a catheter into either the arterial or venous vasculature of the donor to allow the donor's blood to flow out of the donor and be collected into a blood collection bag. The donor's blood is allowed to flow out until the necessary amount of blood is collected, typically 1.0-2.5 liters, whereupon the catheter is removed. The blood extracted through exsanguination is then filtered and added to a fluid reservoir 160 of the system 100 in preparation for use with the system 100. Alternatively, the blood can be exsanguinated from the donor and filtered for leukocytes and platelets in a single step that uses an apparatus having a filter integrated with the cannula and blood collection bag. An example of such a filter is a Pall BC2B filter. After the donor's blood is exsanguinated, the donor heart 102 is injected in step 914 with a cardioplegic solution to temporarily halt beating in preparation for harvesting the heart 102.

[0212] After the heart 102 is arrested, the heart 102 is explanted 916 from the donor and prepared 918 for loading onto the system 100. In general, the steps of explanting the heart 916 and preparing for loading 918 involve severing the connections between the vasculature of the heart 102 and the interior chest cavity of the donor, suturing various of the severed connections, then lifting the heart 102 from the chest cavity.

[0213] More particularly, as shown in FIG. 29B, the right and left pulmonary arteries 164a and 164b are severed, and

the right pulmonary artery **164a** is tied-off by a surgical thread **901a** or other suitable mechanism. The tying prevents fluid from flowing through the severed end **903a** of the left pulmonary artery **164a**. As described above with reference to FIGS. **24A-24B**, the left pulmonary artery **164b** remains unsutured to allow it to be cannulated to the organ chamber assembly **104**, thereby allowing perfusion fluid **108** to flow through the left pulmonary artery **164b**, through the pulmonary artery cannulation interface **170**, and back to the reservoir **160**. The left pulmonary veins **168b** and **169b** and the right pulmonary veins **168a** and **169a** are also severed, and all except a single pulmonary vein **169b** are tied off with surgical thread **901b**, **901c**, and **901d**, respectively. This prevents fluid from flowing through the severed ends **903b** and **903c** of the right pulmonary veins **168a** and **169a**, or through the severed end **903d** of the left pulmonary vein **168b**, but allows the untied pulmonary vein to be cannulated to the organ chamber assembly **104** through the pulmonary vein interface **170**. As described above with reference to FIGS. **24A-24B**, this arrangement allows the perfusion fluid **108** to flow through the right pulmonary artery **164b**, through the pulmonary artery interface **166**, and back to the oxygenator **114**. Alternatively, blood can be expelled from the right ventricle via cannulating the pulmonary arterial trunk. The pulmonary arterial trunk is not shown but includes the segment of pulmonary artery **164** between the branches **164a** and **164b** of the pulmonary artery **164** and the right ventricle **159**. The superior vena cava **161** is also severed and, once the heart is connected to the system **100** and begins beating, is tied with thread **901e** to prevent fluid from flowing through its end **903e**. The inferior vena cava **163** is similarly severed and tied with thread **901f** or oversewn to prevent fluid from flowing through its end **903f**. The aorta **158** is also severed (in the illustrated embodiment at a point downstream from the coronary sinus **155**) but is not tied off, allowing it to be cannulated to the organ chamber assembly **104**. In one embodiment, the aorta **158** is cannulated to an aortic connector, which can be easily attached to the aorta interface **170**.

[0214] With continued reference to the flow chart of FIG. **29A**, after the heart vasculature is severed and appropriately tied, the heart **102** is then loaded onto the system **100** by inserting it into the organ chamber assembly **104** and cannulating the aorta **158**, left pulmonary artery **164b**, and a pulmonary vein **169b** to the appropriate points in the organ chamber assembly **104**.

[0215] Often, hearts obtained from donors who have also donated their lungs are missing part or all of the left atrium **152**. In this situation, the heart **102** can still be instrumented and perfused in the retrograde mode by cannulating the aorta **158** and either the right pulmonary artery **164a** or pulmonary artery trunk (not shown, but described above), and allowing any remaining left atrium **152** portion to remain open during the preservation period.

[0216] With continued reference to FIG. **29A**, during the preparation of the heart via path **906**, the system **100** is prepared through the steps of path **908** so it is primed and waiting to receive the heart **102** for cannulation and transport as soon as the heart **102** is prepared. By quickly transferring the heart **102** from the donor to the system **100**, and subsequently perfusing the heart **102** with the perfusion fluid **108**, a medical operator can minimize the amount of time the heart **102** is deprived of oxygen and other nutrients, and thus reduce ischemia and other ill effects that arise

during current organ care techniques. In certain embodiments, the amount of time between infusing the heart **102** with cardioplegic solution and beginning flow of the perfusion fluid **108** through the heart **102** via the system **100** is less than about 15 minutes. In other illustrative embodiments, the between-time is less than about hour, less than about 1 hour, less than about 2 hours, or even less than about 3 hours. Similarly, the time between transplanting the heart into an organ care system **100** and bringing the heart **102** to a near physiological temperature (e.g., between about 34° C. and about 37° C.) occurs within a brief period of time so as to reduce ischemia within the heart tissues. In some illustrative embodiments, the period of time is less than about 5 minutes, while in other applications it may be less than about hour, less than about 1 hour, less than about 2 hours, or even less than about 3 hours. According to some illustrative embodiments, the heart can be transferred directly from the donor to the system **100**, without the use of cardioplegia, and in such applications the time to beginning the flow of warm perfusion fluid **108** and/or time to the heart reaching near physiologic temperature is similarly less than about 5 minutes, less than about ½ h hour, less than about 1 hour, less than about 2 hours, or even less than about 3 hours. In one implementation, the donor heart is not arrested prior to removal from the donor, and is instrumented onto the system **100** while the heart **102** is still beating.

[0217] As shown in FIG. **29A**, the system **100** is prepared in pathway **908** through a series of steps, which include preparing the single use module **634** (step **922**), priming the system **100** with priming solution (step **924**), filtering the blood from the donor and adding it to the system **100** reservoir **160** (step **912**), and connecting the heart **102** into the system **100** (step **904**). In particular, the step **922** of preparing the single use module **634** includes assembling the disposable single use module **634**. Suitable assemblies are shown, for example, in FIGS. **24A-24D**, FIGS. **25A-25C**, and FIG. **26**. After the module **634** is assembled, or provided in the appropriate assembly, it is then inserted into multiple use module **650** through the process described above with reference to FIGS. **21A-21C**.

[0218] In step **924**, the loaded system **100** is primed with priming solution, as described in more particular detail below with reference to Table 1. According to one feature, to aid in priming, the system **100** provides an organ bypass conduit **810** shown installed into the organ chamber assembly **104** in FIG. **27A**. As depicted, the bypass conduit includes three segments **810a-810c**. Segment **810a** attaches to the pulmonary artery cannulation interface **170**. The segment **810b** attaches to the aorta cannulation interface **810b**, and the segment **810c** attaches to the pulmonary vein cannulation interface **166**. Using the bypass conduit **810** so attached/cannulated to into the organ chamber assembly **104**, an operator can cause the system **100** to circulate the perfusion fluid **108** through all of the paths used during actual operation. This enables the system **100** to be thoroughly tested and primed prior to cannulating the heart **102** into place.

[0219] In the next step **912**, blood from the donor is filtered and added to the reservoir **160**. The filtering process helps reduce the inflammatory process through the complete or partial removal of leukocytes and platelets. Additionally, the donor blood is mixed with one or more nutritional **116** and/or preservative **118** solutions to form the perfusion fluid **108**. In step **926**, the system **100** is primed with the perfusion

fluid 108 by pumping it through the system 100 in the retrograde flow mode, as described above in reference to FIG. 24B, and with the bypass conduit 810 in place. As the perfusion fluid 108 circulates through the system 100 in priming step 926, it is warmed to the desired temperature as it passes through heater assembly 110. The desired temperature range and heating applications are described above in reference to FIGS. 6A through 6E, and in respect to FIG. 13. In step 920, after the system 100 is primed with the perfusion fluid 108, the bypass conduit 810 is removed, and the heart 102 is instrumented, as described above and shown in FIG. 27B, onto the system 100.

[0220] After the heart 102 is instrumented onto the system 100, the pump 104 is activated and the flow mode valve 112 is positioned in retrograde flow mode (described above with reference to FIGS. 1 and 4) to pump the perfusion fluid 108 in retrograde flow mode through the aorta into the vasculature of the heart 102. The pumping of the warm, oxygen and nutrient enriched perfusion fluid 108 through the heart 102 allows the heart 102 to function ex vivo in a near normal physiologic state. In particular, the warm perfusion fluid 108 warms the heart 102 as it perfuses through it, which may cause the heart 102 to resume beating in its natural fashion. In some instances, it is desirable to assist the heart 102 in resuming its beating, which may be done by providing hand massage or a defibrillation signal 143 (shown in FIG. 22E) to the heart 102. This may be done as described above with reference to the organ chamber assembly of FIGS. 5A-5F and operator interface 146 of FIGS. 17A-17J.

[0221] After the heart is instrumented onto the system 100 at step 920, subsequent steps 928 and 930 allow the operator to test the heart 102 and the system 100, and to evaluate their respective conditions. Illustratively, step 928 involves evaluating ECG signals 379 and 381 from the sensors 142 and 144 (positioned as shown in FIG. 27A), respectively, as well as hematocrit 145 and oxygen saturation 141 levels of the perfusion fluid 108 from the sensor 140. As further described in reference to FIG. 12 and FIGS. 17A-17I, the operator can also monitor the fluid flows, pressures, and temperatures of the system 100 while the heart 102 is cannulated. As described above with reference to FIGS. 5E and 5F, the testing step 928 may also include having the operator touch/examine the heart 102 by lifting an outer lid 196 of the organ chamber 104 and touching/examining the heart 102 indirectly through the flexible membrane 198b. During the evaluation step 930, based on the data and other information obtained during testing 928, the operator determines whether and how to adjust the system 100 properties (e.g., fluid flows, pressures, and temperatures), and whether to provide additional defibrillation, or other needed modes of treatment to the heart 102. The operator makes any such adjustments in step 932, then repeats steps 928 and 930 to re-test and re-evaluate the heart 102 and the system 100. In certain embodiments, the operator may also opt to perform surgical, therapeutic or other procedures on the heart 102 during the adjustment step 932. For example, the operator can conduct an evaluation of the physiological fitness of the heart, such as for example, performing an ultrasound or other imaging test, performing an echocardiogram or diagnostic test on the heart, measuring arterial blood gas levels and other evaluative tests.

[0222] In another application, during or after step 932, the system 100 allows a medical operator to evaluate the organ for compatibility with an intended recipient after explanta-

tion but prior to implantation into the donor. For example, the operator can perform a Human Leukocyte Antigen (HLA) matching test on the organ while the organ is cannulated to the system 100. Such tests may require 12 hours or longer and are performed to ensure compatibility of the organ with the intended recipient. The preservation of an organ using the system 100 described above may allow for preservation times in excess of the time needed to complete an HLA match, potentially resulting in improved post-transplant outcomes. In the HLA matching test example, the HLA test can be performed on the heart while a preservation solution is pumping into the heart.

[0223] According to a further illustrative embodiment, after the heart is functioning as determined by the step 932, the operator can perform surgery on the heart or provide therapeutic or other treatment, such as immunosuppressive treatments, chemotherapy, genetic testing and therapies, or irradiation therapy. Because the system 100 allows the heart 102 to be perfused under near physiological temperature, fluid flow rate, and oxygen saturation levels, the heart 102 can be maintained after the adjustment step 932 for a long period of time (e.g., for a period of at least 3 days or more, greater than at least 1 week, at least 3 weeks, or a month or more) to allow for repeated evaluation and treatment.

[0224] According to the illustrative embodiment, the testing 928, evaluation 930 and adjustment 932 steps may be conducted with the system 100 operating in retrograde flow mode, or may be conducted with the system 100 operating in normal flow mode. In normal flow mode, the operator can test the function of the heart 102 under normal or near normal physiologic blood flow conditions. Based on the evaluation 930, the settings of the system 100 may be adjusted in step 932, if necessary, to modify the flow, heating and/or other characteristics to stabilize the heart 102 in step 934 in preparation for transport to the recipient site in step 936. After the heart 102 and the system 100 is tested and evaluated to ensure appropriate performance, the system 100 with the loaded heart 102 is transported to the recipient site at step 936.

[0225] Referring now to FIG. 30, the first phase 942 of the transplant process involves repeating the testing 928 and evaluation 930 steps undertaken just prior to leaving the donor site 936. If the function and characteristics of the heart 102 are not acceptable, the system 100 can be adjusted 942 as appropriate, for example, to provide appropriate fluid oxygenation or nutritional levels, or to increase or decrease the appropriate fluid temperature. As noted above, surgical and/or other therapeutic/remedial procedures may be performed on the heart 102, along with the testing 928 and evaluation 930. According to the illustrative embodiment, testing at the recipient site may be performed in retrograde flow mode, normal flow mode, or a combination of both.

[0226] At step 946, after testing is complete, the system 100 is placed in normal/forward flow mode. In certain embodiments, this step 946 is not initiated until the left atrium 152 and pulmonary vein 164 are cannulated, there is adequate operating volume in the system, the heart exhibits stable electrical activity, the ABG and electrolytes are within acceptable ranges, SvO₂ is >80%, and blood temperature is between about 34° C. and about 36° C. The step 946 is may be accomplished by slowing and/or stopping the retrograde pumping of the system 100, then restarting the pumping in forward mode. In certain embodiments, prior to restarting in forward mode, the user opens the aortic sampling port 754a,

releases the pressure control clamp **190** by turning it counterclockwise, then increases the flow rate of pump **106** to about 1.0 L/min, sets the flow control valve **112** to normal/forward flow, and increases the flow rate of pump **106** to about 2.0 L/min to allow the blood **102** to displace air in the perfusate lines (e.g., **802**) of the system **100** and pass through the left side of the heart **102** and down the reservoir return line **808**. The user then closes the aortic sampling port **754a**.

[0227] The flow rate of the perfusion fluid **108** emitted from the pump **106** is then increased at step **950** to a level of the clinician's choosing (typically between about 1 L/min to about 5 L/min) to approximate the physiologic flow rate provided by the heart **102** while functioning in normal beating mode. The heart **102** and the system **100** are again tested at step **952** in a similar fashion to that described above with respect to steps **928** and **930**. The clinician may also choose to perform any other tests or evaluations on the heart, for example echocardiogram, electrolyte measurements, cardiac enzyme measurements, metabolite measurements, intravascular ultrasound evaluation, pressure-volume loop evaluation, and Millar pressure evaluation.

[0228] In the third phase **946** at the recipient site, the heart **102** is prepared for implantation into the recipient. This phase includes the step **956** of powering down the pump **106** to stop the flow of perfusion fluid **108**. Next, in step **958**, the heart **102** is arrested, for example by injecting it with cardioplegic solution in a similar fashion to what is done in step **914** at the donor site. In step **960**, the heart **102** is de-cannulated and removed from the organ chamber assembly **106**. In step **962**, the heart **102** is transplanted into the recipient patient by first removing the sutures **901a-901f**, then inserting the heart **102** into the recipient's chest cavity, and suturing the various heart vesicles (e.g., **158**, **164a**, **164b**, **168a**, **168b**, **169a**, **169b**, and **903a-903f**) to their appropriate mating vesicles within the recipient.

[0229] While external devices and methods have been described to defibrillate the heart, deliver pacing signals to the heart, and perform blood chemistry analyses from samples taken from the perfusion fluid, it may also be beneficial to integrate these features into the portable system. Such features include defibrillation, pacing, diagnostic ECG sensing, and blood chemistry analyses.

[0230] As described above, the system **100** employs a priming solution, and also employs a perfusion fluid **108** that combines a nutritional supplement **116** solution and a preservative solution **118** with a blood product or synthetic blood product to form the perfusion fluid **108**. The priming, supplement **116**, and preservative **118** solutions are described next.

[0231] According to certain embodiments, solutions with particular solutes and concentrations are selected and proportioned to enable the organ to function at physiologic or near physiologic conditions. For example, such conditions include maintaining organ function at or near a physiological temperature and/or preserving an organ in a state that permits normal cellular metabolism, such as protein synthesis.

[0232] In certain embodiments solutions are formed from compositions by combining components with a fluid, from more concentrated solutions by dilution, or from more dilute solutions by concentration. In exemplary embodiments, suitable solutions include an energy source, one or more stimulants to assist the organ in continuing its normal physiologic

function prior to and during transplantation, and one or more amino acids selected and proportioned so that the organ continues its cellular metabolism during perfusion. Cellular metabolism includes, for example conducting protein synthesis while functioning during perfusion. Some illustrative solutions are aqueous based, while other illustrative solutions are non-aqueous, for example organic solvent-based, ionic-liquid-based, or fatty-acid-based.

[0233] The solutions may include one or more energy-rich components to assist the organ in conducting its normal physiologic function. These components may include energy rich materials that are metabolizable, and/or components of such materials that an organ can use to synthesize energy sources during perfusion. Exemplary sources of energy-rich molecules include, for example, one or more carbohydrates. Examples of carbohydrates include monosaccharides, disaccharides, oligosaccharides, polysaccharides, or combinations thereof, or precursors or metabolites thereof. While not meant to be limiting, examples of monosaccharides suitable for the solutions include octoses; heptoses; hexoses, such as fructose, allose, altrose, glucose, mannose, gulose, idose, galactose, and talose; pentoses such as ribose, arabinose, xylose, and lyxose; tetroses such as erythrose and threose; and trioses such as glyceraldehyde. While not meant to be limiting, examples of disaccharides suitable for the solutions include (+)-maltose (4-O-(α -D-glucopyranosyl)- α -D-glucopyranose), (+)-cellobiose (4-O-(β -D-glucopyranosyl)-D-glucopyranose), (+)-lactose (4-O-(β -D-galactopyranosyl)- β -D-glucopyranose), sucrose (2-O-(α -D-glucopyranosyl)- β -D-fructofuranoside). While not meant to be limiting, examples of polysaccharides suitable for the solutions include cellulose, starch, amylose, amylopectin, sulfomucopolysaccharides (such as dermatan sulfate, chondroitin sulfate, sulodexide, mesoglycans, heparan sulfates, idosanes, heparins and heparinoids), and glycogen. In some embodiments, monosaccharides, disaccharides, and polysaccharides of both aldoses, ketoses, or a combination thereof are used. One or more isomers, including enantiomers, diastereomers, and/or tautomers of monosaccharides, disaccharides, and/or polysaccharides, including those described and not described herein, may be employed in the solutions described herein. In some embodiments, one or more monosaccharides, disaccharides, and/or polysaccharides may have been chemically modified, for example, by derivatization and/or protection (with protecting groups) of one or more functional groups. In certain embodiments, carbohydrates, such as dextrose or other forms of glucose are preferred.

[0234] Other possible energy sources include adenosine triphosphate (ATP), co-enzyme A, pyruvate, flavin adenine dinucleotide (FAD), thiamine pyrophosphate chloride (co-carboxylase), β -nicotinamide adenine dinucleotide (NAD), β -nicotinamide adenine dinucleotide phosphate (NADPH), and phosphate derivatives of nucleosides, i.e. nucleotides, including mono-, di-, and tri-phosphates (e.g., UTP, GTP, GDF, and UDP), coenzymes, or other bio-molecules having similar cellular metabolic functions, and/or metabolites or precursors thereof. For example, phosphate derivatives of adenosine, guanosine, thymidine (**5-Me-uridine**), cytidine, and uridine, as well as other naturally and chemically modified nucleosides are contemplated.

[0235] In certain embodiments, one or more carbohydrates is provided along with a phosphate source, such as a nucleotide. The carbohydrate helps enable the organ to,

produce ATP or other energy sources during perfusion. The phosphate source may be provided directly through ATP, ADP, AMP or other sources. In other illustrative embodiments, a phosphate is provided through a phosphate salt, such as glycerophosphate, sodium phosphate or other phosphate ions. A phosphate may include any form thereof in any ionic state, including protonated forms and forms with one or more counter ions.

[0236] The solutions may include one or more organ stimulants for assisting the organ's normal physiologic function during perfusion. In some illustrative embodiments, where the transplanted organ is a heart, cardio stimulants are provided to enable the heart to continue functioning (e.g., continue beating) during perfusion and transplantation. Such stimulants may include, for example, catecholamines, such as epinephrine and/or norepinephrine, which facilitate beating of the heart. Other cardio stimulants may be used, such as certain forms of peptides and/or polypeptides (e.g., vasopressin, Anthropleurin-A and Anthropleurin-B), and/or β 1/ β 2-adrenoreceptor blocking agents (such as CGP 12177), buplinarol, pindolol, alprenolol, and cardiac glycosides. One or more natural products may also be used, such as digitalis (digoxin), palustrin, and/or ferulic acid. Stimulants such as those mentioned above can be included with the solutions or added at the point of use by the user.

[0237] In some instances, additional components are provided to assist the organ in conducting its metabolism during perfusion. These components include, for example, forms or derivatives of adenine and/or adenosine, which may be used for ATP synthesis, for maintaining endothelial function, and/or for attenuating ischemia and/or reperfusion injury. According to certain implementations, a magnesium ion source is provided with a phosphate, and in certain embodiments, with adenosine to further enhance ATP synthesis within the cells of the perfused organ.

[0238] Solutions described herein may include one or more amino acids, preferably a plurality of amino acids, to support protein synthesis by the organ's cells. Suitable amino acids include, for example, any of the naturally-occurring amino acids. The amino acids may be, in various enantiomeric or diastereomeric forms. For example, solutions may employ either D- or L-amino acids, or a combination thereof, i.e. solutions enantioenriched in more of the D- or L-isomer or racemic solutions. Suitable amino acids may also be non-naturally occurring or modified amino acids, such as citrulline, ornithine, homocystein, homoserine, β -amino acids such as β -alanine, amino-caproic acid, or combinations thereof.

[0239] Certain exemplary solutions include some but not all naturally-occurring amino acids. In some embodiments, solutions include essential amino acids. For example, a solution may be prepared with one or more or all of the following amino-acids:

Glycine
Alanine
Arginine
Aspartic Acid
Glutamic Acid
Histidine
Isoleucine
Leucine
Methionine

-continued

Phenylalanine
Proline
Serine
Threonine
Tryptophan
Tyrosine
Valine
Lysine acetate

[0240] In certain embodiments, non-essential and/or semi-essential amino acids are not included in the solutions. For example, in some embodiments, asparagine, glutamine, and/or cysteine are not included. In other embodiments, the solution contains one or more non-essential and/or semi-essential amino acids. Accordingly, in other embodiments, asparagine, glutamine, and/or cysteine are included.

[0241] The solutions may also contain electrolytes, particularly calcium ions for facilitating enzymatic reactions, cardiac contractility, and/or coagulation within the organ. Other electrolytes may be used, such as sodium, potassium, chloride, sulfate, magnesium and other inorganic and organic charged species, or combinations thereof. It should be noted that any component provided hereunder may be provided, where valence and stability permit, in an ionic form, in a protonated or unprotonated form, in salt or free base form, or as ionic or covalent substituents in combination with other components that hydrolyze and make the component available in aqueous solutions, as suitable and appropriate.

[0242] In certain embodiments, the solutions contain buffering components. For example, suitable buffer systems include 2-morpholinoethanesulfonic acid monohydrate (MES), cacodylic acid, $\text{H}_2\text{CO}_3/\text{NaHCO}_3$ (pK_{a1}), citric acid (pK_{a3}), bis(2-hydroxyethyl)-imino-tris-(hydroxymethyl)-methane (Bis-Tris), N-carbamoylmethylimidino acetic acid (ADA), 3-bis[tris(hydroxymethyl)methylamino]propane (Bis-Tris Propane) (pK_{a1}), piperazine-1,4-bis(2-ethanesulfonic acid) (PIPES), N-(2-Acetamido)-2-aminoethanesulfonic acid (ACES), imidazole, N,N-bis(2-hydroxyethyl)-2-aminoethanesulfonic acid (BES), 3-(N-morpholino)propanesulphonic acid (MOPS), $\text{NaH}_2\text{PO}_4/\text{Na}_2\text{HPO}_4$ (pK_{a2}), tris(hydroxymethyl)methyl-2-aminoethanesulfonic acid (TES), N-(2-hydroxyethyl)-piperazine-N'-2-ethanesulfonic acid (HEPES), N-(2-hydroxyethyl)piperazine-N'-(2-hydroxypropanesulfonic acid) (HEPPSO), triethanolamine, N-[tris(hydroxymethyl)methyl]glycine (Tricine), tris hydroxymethylaminoethane (Tris), glycineamide, N,N-bis(2-hydroxyethyl) glycine (Bicine), glycylglycine (pK_{a2}), N-tris(hydroxymethyl)methyl-3-aminopropanesulfonic acid (TAPS), or a combination thereof. In some embodiments, the solutions contain sodium bicarbonate, potassium phosphate, or TRIS buffer.

[0243] The solutions may include other components to help maintain the organ and protect it against ischemia, reperfusion injury and other ill effects during perfusion. In certain exemplary embodiments these components may include hormones (e.g., insulin), vitamins (e.g., an adult multi-vitamin, such as multi-vitamin MVI-Adult), and/or steroids (e.g., dexamethasone and SoluMedrol).

[0244] In another aspect, a blood product is provided with the solution to support the organ during metabolism. Exemplary suitable blood products may include whole blood, and/or one or more components thereof such as blood serum,

plasma, albumin, and red blood cells. In embodiments where whole blood is used, the blood may be passed through a leukocyte and platelet depleting filter to reduce pyrogens, antibodies and/or other items that may cause inflammation in the organ. Thus, in some embodiments, the solution employs whole blood that has been at least partially depleted of leukocytes and/or whole blood that has been at least partially depleted of platelets.

[0245] The solutions are preferably provided at a physiological temperature and maintained thereabout throughout perfusion and recirculation. As used herein, “physiological temperature” is referred to as temperatures between about 25° C. and about 37° C., for example, between about 30° C. and about 37° C., such as between about 34° C. and about 37° C.

[0246] Table 1 sets forth components that are used in an exemplary aqueous priming solution. The component amounts in Table 1 are relative to each other and to the amount of aqueous solvent employed in the solution (about 500 mL in the exemplary embodiment) and may be scaled as appropriate. In certain embodiments, the quantity of aqueous solvent varies \pm about 10%.

TABLE 1

Composition of Exemplary Priming Solution (about 500 mL aqueous solution)		
Component	Amount	Specification
Mannitol	12.5 g	\pm about 10%
Sodium Chloride	4.8 g	\pm about 10%
Potassium Chloride	185 mg	\pm about 10%
Magnesium Sulfate heptahydrate	185 mg	\pm about 10%
Sodium Glycerophosphate	900 mg	\pm about 10%

The exemplary priming solution is added to the system **100** through priming step **924**, as more fully described with reference to FIG. **29A**.

[0247] With regard to the nutritional supplement solution **116**, in certain embodiments it includes one or more carbohydrates and may also include a phosphate source. The nutritional supplement solution **116** is typically maintained at a pH of about 5.0 to about 6.5, for example about 5.5 to about 6.0.

[0248] Table 2 sets forth components that are used in an exemplary nutritional supplement solution **116**. In some embodiments, the nutritional solution **116** further includes sodium glycerol phosphate. The amount of components in Table 2 is relative to the amount of aqueous solvent employed in the solution **116** (about 500 mL) and may be scaled as appropriate. In some embodiments, the quantity of aqueous solvent varies \pm about 10%.

TABLE 2

Components of Exemplary Nutritional Solution (about 500 mL)		
Component	Amount	Specification
Dextrose	40 g	\pm about 10%

[0249] In certain embodiments the nutritional solution **116** includes one or more carbohydrates and may also include a phosphate source. The nutritional solution **116** is typically maintained at a pH of about 5.0 to about 6.5, for example of about 5.5 to about 6.0.

[0250] The preservation solution **118** may include one or more preservatives. In an exemplary embodiment, one or more cardio stimulants are included for assisting normal physiologic function of the heart **102** during perfusion and transplantation. Such stimulants may include, for example, catecholamines, such as epinephrine and/or norepinephrine, which facilitate beating of the heart.

[0251] Other components may be added to the preservation solution **118**, including, for example, adenosine, magnesium, phosphate, calcium, and/or sources thereof. In some instances, additional components are provided to assist the organ in conducting its metabolism during perfusion. These components include, for example, forms of adenosine, which may be used for ATP synthesis, for maintaining endothelial function, and/or for attenuating ischemia and/or reperfusion injury. Components may also include other nucleosides, such as guanosine, thymidine (**5-Me-uridine**), cytidine, and uridine, as well as other naturally and chemically modified nucleosides including nucleotides thereof. According to some implementations, a magnesium ion source is provided with a phosphate source, and in certain embodiments, with adenosine to further enhance ATP synthesis within the cells of the perfused organ. A plurality of amino acids may also be added to support protein synthesis by the heart's **102** cells. Applicable amino acids may include, for example, any of the naturally-occurring amino acids, as well as those mentioned above.

[0252] Table 3 sets forth components that may be used in a solution **118** for preserving an organ as described herein. The solution **118** may include one or more of the components described in Table 3.

TABLE 3

Component of Exemplary Composition for Preservative Solution	
Component	Exemplary Concentration Ranges in Preservative Solution
Alanine	about 1 mg/L-about 10 g/L
Arginine	about 1 mg/L-about 10 g/L
Asparagine	about 1 mg/L-about 10 g/L
Aspartic Acid	about 1 mg/L-about 10 g/L
Cysteine	about 1 mg/L-about 10 g/L
Cystine	about 1 mg/L-about 10 g/L
Glutamic Acid	about 1 mg/L-about 10 g/L
Glutamine	about 1 mg/L-about 10 g/L
Glycine	about 1 mg/L-about 10 g/L
Histidine	about 1 mg/L-about 10 g/L
Hydroxyproline	about 1 mg/L-about 10 g/L
Isoleucine	about 1 mg/L-about 10 g/L
Leucine	about 1 mg/L-about 10 g/L
Lysine	about 1 mg/L-about 10 g/L
Methionine	about 1 mg/L-about 10 g/L
Phenylalanine	about 1 mg/L-about 10 g/L
Proline	about 1 mg/L-about 10 g/L
Serine	about 1 mg/L-about 10 g/L
Threonine	about 1 mg/L-about 10 g/L
Tryptophan	about 1 mg/L-about 10 g/L
Tyrosine	about 1 mg/L-about 10 g/L
Valine	about 1 mg/L-about 10 g/L
Adenine	about 1 mg/L-about 10 g/L
ATP	about 10 ug/L-about 100 g/L
Adenylic Acid	about 10 ug/L-about 100 g/L
ADP	about 10 ug/L-about 100 g/L
AMP	about 10 ug/L-about 100 g/L
Ascorbic Acid	about 1 ug/L-about 10 g/L
D-Biotin	about 1 ug/L-about 10 g/L
Vitamin D-12	about 1 ug/L-about 10 g/L
Cholesterol	about 1 ug/L-about 10 g/L
Dextrose (Glucose)	about 1 g/L-about 150 g/L

TABLE 3-continued

Component of Exemplary Composition for Preservative Solution	
Component	Exemplary Concentration Ranges in Preservative Solution
Multi-vitamin Adult	about 1 mg/L-about 20 mg/L or 1 unit vial
Epinephrine	about 1 ug/L-about 1 g/L
Folic Acid	about 1 ug/L-about 10 g/L
Glutathione	about 1 mg/L-about 10 g/L
Guanine	about 1 ug/L-about 10 g/L
Inositol	about 1 g/L-about 100 g/L
Riboflavin	about 1 ug/L-about 10 g/L
Ribose	about 1 ug/L-about 10 g/L
Thiamine	about 1 mg/L-about 10 g/L
Uracil	about 1 mg/L-about 10 g/L
Calcium Chloride	about 1 mg/L-about 100 g/L
NaHCO ₃	about 1 mg/L-about 100 g/L
Magnesium sulfate	about 1 mg/L-about 100 g/L
Potassium chloride	about 1 mg/L-about 100 g/L
Sodium glycerophosphate	about 1 mg/L-about 100 g/L
Sodium Chloride	about 1 mg/L-about 100 g/L
Sodium Phosphate	about 1 mg/L-about 100 g/L
Insulin	about 1 IU-about 150 IU
Serum albumin	about 1 g/L-about 100 g/L
Pyruvate	about 1 mg/L-about 100 g/L
Coenzyme A	about 1 ug/L-about 10 g/L
Serum	about 1 ml/L-about 100 ml/L
Heparin	about 500 U/L-about 1500 U/L
Solumedrol	about 200 mg/L-about 500 mg/L
Dexamethasone	about 1 mg/L-about 1 g/L
FAD	about 1 ug/L-about 10 g/L
NADP	about 1 ug/L-about 10 g/L
adenosine	about 1 mg/L-about 10 g/L
guanosine	about 1 mg/L-about 10 g/L
GTP	about 10 ug/L-about 100 g/L
GDP	about 10 ug/L-about 100 g/L
GMP	about 10 ug/L-about 100 g/L

[0253] Table 4 sets forth components that are used in an exemplary preservative solution 118. The amounts provided in Table 4 describe preferred amounts relative to other components in the table and may be scaled to provide compositions of sufficient quantity. In some embodiments, the amounts listed in Table 4 can vary by \pm about 10% and still be used in the solutions described herein.

TABLE 4

Components of Exemplary Preservative Solution	
Component	Amount
Adenosine	About 675 mg-About 825 mg
Calcium Chloride dihydrate	About 2100 mg-About 2600 mg
Glycine	About 315 mg-About 385 mg
L-Alanine	About 150 mg-About 200 mg
L-Arginine	About 600 mg-About 800 mg
L-Aspartic Acid	About 220 mg-About 270 mg
L-Glutamic Acid	About 230 mg-About 290 mg
L-Histidine	About 200 mg-About 250 mg
L-Isoleucine	About 100 mg about 130 mg
L-Leucine	About 300 mg-About 380 mg
L-Methionine	About 50 mg-About 65 mg
L-Phenylalanine	About 45 mg-About 60 mg
L-Proline	About 110 mg-About 140 mg
L-Serine	About 80 mg-About 105 mg
L-Threonine	About 60 mg-About 80 mg
L-Tryptophan	About 30 mg-About 40 mg
L-Tyrosine	About 80 mg-About 110 mg
L-Valine	About 150 mg-About 190 mg
Lysine Acetate	About 200 mg-About 250 mg
Magnesium Sulfate Heptahydrate	About 350 mg-About 450 mg
Potassium Chloride	About 15 mg-About 25 mg

TABLE 4-continued

Components of Exemplary Preservative Solution	
Component	Amount
Sodium Chloride	About 1500 mg-About 2000 mg
Dextrose	About 25 gm-About 120 gm
Epinephrine	About 0.25 mg-About 1.0 mg
Insulin	About 75 Units-About 150 Units
MVI-Adult	1 unit vial
SoluMedrol	about 200 mg-500 mg
Sodium Bicarbonate	About 10-25 mEq

[0254] In the exemplary embodiment of a solution 118, the components in Table 4 are combined in the relative amounts listed therein per about 1 L of aqueous fluid to form the solution 118. In some embodiments, the components in Table 4 are combined in the relative amounts listed therein per about 500 mL of aqueous fluid and then combined with the solution 116, also about 500 mL, to provide a maintenance solution 116/118 of about 1 L of aqueous fluid. In some embodiments the quantity of aqueous fluid in solutions 116, 118, and/or 116/118 can vary \pm about 10%. The pH of the solution 118 may be adjusted to be between about 7.0 and about 8.0, for example about 7.3 and about 7.6. The solution 118 may be sterilized, for example by autoclaving, to provide for improved purity.

[0255] Table 5 sets forth another exemplary preservative solution 118, comprising a tissue culture media having the components identified in Table 5 and combined with an aqueous fluid, which may be used in the perfusion fluid 108 as described herein. The amounts of components listed in Table 5 are relative to each other and to the quantity of aqueous solution used. In some embodiments, about 500 mL of aqueous fluid is used. In other embodiments about 1 L of aqueous fluid is used. For example, combination of about 500 mL of preservative solution 118 with 500 mL of nutritional solution 116 affords a maintenance solution 116/118 of about 1 L. In some embodiments, the quantity of aqueous solution can vary \pm about 10%. The component amounts and the quantity of aqueous solution may be scaled as appropriate for use. The pH of the preservative solution 118, in this embodiment, may be adjusted to be about 7.0 to about 8.0, for example about 7.3 to about 7.6.

TABLE 5

Composition of Another Exemplary Preservative Solution (about 500 mL aqueous solution)		
Tissue Culture Component	Amount	Specification
Adenosine	750 mg	\pm about 10%
Calcium Chloride dihydrate	2400 mg	\pm about 10%
Glycine	350 mg	\pm about 10%
L-Alanine	174 mg	\pm about 10%
L-Arginine	700 mg	\pm about 10%
L-Aspartic Acid	245 mg	\pm about 10%
L-Glutamic Acid	258 mg	\pm about 10%
L-Histidine	225 mg	\pm about 10%
L-Isoleucine	115.5 mg	\pm about 10%
L-Leucine	343 mg	\pm about 10%
L-Methionine	59 mg	\pm about 10%
L-Phenylalanine	52 mg	\pm about 10%
L-Proline	126 mg	\pm about 10%
L-Serine	93 mg	\pm about 10%
L-Threonine	70 mg	\pm about 10%
L-Tryptophan	35 mg	\pm about 10%
L-Tyrosine	92 mg	\pm about 10%

TABLE 5-continued

Composition of Another Exemplary Preservative Solution (about 500 mL aqueous solution)		
Tissue Culture Component	Amount	Specification
L-Valine	171.5 mg	±about 10%
Lysine Acetate	225 mg	±about 10%
Magnesium Sulfate Heptahydrate	400 mg	±about 10%
Potassium Chloride	20 mg	±about 10%
Sodium Chloride	1750 mg	±about 10%

[0256] Since amino acids are the building blocks of proteins, the unique characteristics of each amino acid impart certain important properties on a protein such as the ability to provide structure and to catalyze biochemical reactions. The selection and concentrations of the amino acids provided in the preservative solutions provide support of normal physiologic functions such as metabolism of sugars to provide energy, regulation of protein metabolism, transport of minerals, synthesis of nucleic acids (DNA and RNA), regulation of blood sugar and support of electrical activity, in addition to providing protein structure. Additionally, the concentrations of specific amino acids found in the preservative solutions can be used to predictably stabilize the pH of the maintenance solution **116/118** and perfusion fluid **108**.

[0257] Certain embodiments of the preservative solution **118** include epinephrine and a plurality of amino acids. In certain embodiments, the preservative solution **118** includes electrolytes, such as calcium and magnesium.

[0258] In one embodiment, a maintenance solution **116/118** is made from the combination of the preservative solution **118**, including one or more amino acids, and the nutritional solution **116**, including one or more carbohydrates, such as glucose or dextrose. The maintenance solution **116/118** may also have additives, such as those described herein, administered at the point of use just prior to infusion into the organ perfusion system. For example, additional additives that can be included with the solution or added at the point of use by the user include hormones and steroids, such as dexamethasone and insulin, as well as vitamins, such as an adult multi-vitamin, for example adult multivitamins for infusion, such as MVI-Adult. Additional small molecules and large bio-molecules may also be included with the solution or added at the point of use by the user at port **762**, for example, therapeutics and/or components typically associated with blood or blood plasma, such as albumin.

[0259] In some embodiments, therapeutics that may be included in the compositions, solutions, and systems described herein include hormones, such as thyroid hormones, for example T₃ and/or T₄ thyroid hormones. Further therapeutics that may be included include drugs such as anti-arrhythmic drugs, for example, for heart therapy, and beta blockers. For instance, in certain embodiments, one or more thyroid hormones, one or more anti-arrhythmic drugs, and one or more beta blockers are added to the nutritional solution **116**, the preservative solution **118**, and/or the maintenance solutions **116/118** either before or during perfusion of the organ. The above therapeutics may also be added directly to the system, for example, to the perfusion fluid **108**, before or during perfusion of the organ.

[0260] With further reference to Table 4, certain components used in the exemplary preservation solution **118** are molecules, such as small organic molecules or large bio-

molecules, that would be inactivated, for example through decomposition or denaturing, if passed through sterilization. According to the system **100**, the inactivatable components of the solution **118** may be prepared separately from the remaining components of the solution **118**. The separate preparation involves separately purifying each component through known techniques. The remaining components of the solution **118** are sterilized, for example through an autoclave, then combined with the biological components.

[0261] Table 6 lists certain biological components that may be separately purified and added to the solutions described herein after sterilization, according to this two-step process. These additional or supplemental components may be added to solutions **118**, **116**, **116/118**, the priming solution or a combination thereof individually, in various combinations, all at once as a composition, or as a combined solution. For example, in certain embodiments, the epinephrine, insulin, and MVI-Adult, listed in Table 6, are added to the maintenance solution **116/118**. In another example, the SoluMedrol and the sodium bicarbonate, listed in Table 6, are added to the priming solution. The additional components may also be combined in one or more combinations or all together and placed in solution before being added to solutions **116**, **118**, **116/118**, and/or the priming solution. In some embodiments, the additional components are added directly to the perfusion fluid **108** through port **762**. The component amounts listed in Table 6 are relative to each other and/or to the amounts of components listed in one or more of Tables 1-5 as well as the amount of aqueous solution used in preparing solutions **116**, **118**, **116/118**, and/or the priming solution and may be scaled as appropriate for the amount of solution required.

TABLE 6

Exemplary Biological Components Added Prior to Use			
Component	Amount	Type	Specification
Epinephrine	About 0.50 mg	Catecholamine Hormone	±about 10%
Insulin	about 100 Units	Hormone	±about 10%
MVI-Adult	1 mL unit vial	Vitamin	±about 10%
SoluMedrol	About 250 mg	Steroid	±about 10%
Sodium Bicarbonate	About 20 mEq	Buffer	±about 10%

[0262] In one embodiment, a composition for use in a maintenance solution **116/118** is provided comprising one or more carbohydrates, one or more organ stimulants, and a plurality of amino acids that do not include asparagine, glutamine, or cysteine. The composition may also include other substances, such as those used in solutions described herein.

[0263] In another embodiment, a system for perfusing an organ, such as a heart, is provided comprising an organ and a substantially cell-free composition, comprising one or more carbohydrates, one or more organ stimulants, and a plurality of amino acids that do not include asparagine, glutamine, or cysteine. Substantially cell-free includes systems that are substantially free from cellular matter; in particular, systems that are not derived from cells. For example, substantially cell-free includes compositions and solutions prepared from non-cellular sources.

[0264] In another aspect, the solutions **116** and **118** may be provided in the form of a kit that includes one or more organ

maintenance solutions. An exemplary maintenance solution may include components identified above in one or more fluid solutions for use in an organ perfusion fluid **108**. In certain embodiments, the maintenance solution **116/118** may include multiple solutions, such as a preservation solution **118** and a nutritional solution **116** and/or a supplemental composition or solution, or may include dry components that may be regenerated in a fluid to form one or more solutions **116/118**. The kit may also comprise components from the solutions **116** and/or **118** in one or more concentrated solutions which, on dilution, provide a preservation, nutritional, and/or supplemental solution as described herein. The kit may also include a priming solution. In an exemplary embodiment, the maintenance solution includes a preservation solution **118** and a nutritional solution **116** such as those described above, and a priming solution such as that described above.

[0265] In certain embodiments, the kit is provided in a single package, wherein the kit includes one or more solutions (or components necessary to formulate the one or more solutions by mixing with an appropriate fluid), and instructions for sterilization, flow and temperature control during perfusion and use and other information necessary or appropriate to apply the kit to organ perfusion. In certain embodiments, a kit is provided with only a single solution **116**, **118** and/or **116/118** (or set of dry components for use in a solution upon mixing with an appropriate fluid), and the single solution **116**, **118** and/or **116/118** (or set of dry components) is provided along with a set of instructions and other information or materials necessary or useful to operate the solution **116**, **118** and/or **116/118** in the system **100**.

[0266] In another aspect, the systems, solutions and methods may be used to deliver therapeutics to an organ during perfusion. For example, one or more of the solutions and/or systems described above may include one or more drugs, biologics, gene therapy vectors, or other therapeutics which are delivered to the organ during perfusion. Suitable exemplary therapeutics may include drugs, biologics, or both. Suitable drugs may include, for example, anti-fungals, anti-microbials or anti-biotics, anti-inflammatories, anti-proliferatives, anti-virals, steroids, retinoids, NSAIDs, vitamin D3 and vitamin D3 analogs, calcium channel blockers, complement neutralizers, ACE inhibitors, immuno-suppressants, and other drugs. Suitable biologics may include proteins; suitable biologics may also include vectors loaded with one or more genes for gene therapy application.

[0267] For example, suitable steroids include but are not limited to androgenic and estrogenic steroid hormones, androgen receptor antagonists and 5- α -reductase inhibitors, and corticosteroids. Specific examples include but are not limited to alclometasone, clobetasol, fluocinolone, fluocortolone, diflucortolone, fluticasone, halcinonide, mometasone, prednisone, prednisolone, methylprednisolone, triamcinolone, betamethasone, and dexamethasone, and various esters and acetones thereof.

[0268] Suitable retinoids include but are not limited to retinol, retinal, isotretinoin, acitretin, adapalene, tazarotene, and bexarotene.

[0269] Suitable NSAIDs include but are not limited to naproxen, suprofen, ketoprofen, ibuprofen, flurbiprofen, diclofenac, indomethacin, celecoxib, and rofecoxib.

[0270] Suitable vitamin D3 analogues include but are not limited to doxercalciferol, seocalcitol, calcipotriene, tacalcitol, calcitriol, ergocalciferol, and calcifediol.

[0271] Suitable anti-viral agents include but are not limited to trifluridine, cidofovir, acyclovir, penciclovir, famciclovir, valacyclovir, gancyclovir, and docosanol.

[0272] Suitable human carbonic anhydrase inhibitors include but are not limited to methazolamide, acetazolamide, and dorzolamide.

[0273] Suitable anti-proliferative agents include but are not limited to 5-FU, taxol, daunorubicin, and mitomycin.

[0274] Suitable antibiotic (antimicrobial) agents include but are not limited to bacitracin, chlorhexidine, chlorhexidine digluconate, ciprofloxacin, clindamycin, erythromycin, gentamicin, lomefloxacin, metronidazole, minocycline, moxifloxacin, mupirocin, neomycin, ofloxacin, polymyxin B, rifampicin, riflozacin, tetracycline, tobramycin, triclosan, and vancomycin. The antiviral and antibacterial prodrugs described herein may be used to treat appropriately responsive systemic infections.

[0275] In certain embodiments, a solution system for use in a perfusion fluid **108**, comprising a first chamber containing a first solution, such as a preservation solution **118**, that includes one or more cardio stimulants and a plurality of amino acids that do not include asparagine, glutamine, or cysteine, and a second chamber, containing a second solution, such as a nutritional solution **116**, that includes one or more carbohydrates, such as dextrose. The system may also include a sterilization system for sterilizing the first solution and the second solution prior to using the solutions to perfuse a heart. In some embodiments, one or more of the solutions **118** and **116** includes one or more therapeutics. In some embodiments the solution system includes a third chamber comprising a priming solution, such as is described above, which may have one or more carbohydrates. In certain embodiments, the first solution **118** includes epinephrine, adenosine, insulin, one or more immuno-suppressants, a multi-vitamin, and/or one or more electrolytes.

[0276] Certain experimental data are available to describe certain embodiments of the solutions described herein and their use in organ perfusion. Certain data are set forth in FIGS. **31-33**. FIG. **31** depicts a chart demonstrating electrolyte stability for an organ under going perfusion in forward mode according to an embodiment of the system **100**. In the embodiment associated with FIG. **31**, the organ is a heart **102** wherein perfusion is conducted in forward mode (as described above) by pumping perfusion fluid **108** containing solution **116/118** to the left atria **152** and out of the aorta **158**. The rate of perfusion is approximately 30 mL/hr. As can be seen from FIG. **31**, the levels of various electrolytes: sodium, potassium, calcium, and chloride ions, as well as dissolved glucose, remain at stable levels throughout the course of perfusion, from before the organ is cannulated to the perfusion system **100** to six hours after cannulation within the system **100**.

[0277] FIG. **32** depicts a chart demonstrating electrolyte stability for an organ under going retrograde perfusion according to another embodiment of the system **100**. In the embodiment associated with FIG. **32**, the organ is a heart wherein perfusion occurs by pumping the perfusion fluid **108** containing the solution **116/118** into the aorta **158** and through the coronary sinus **155**. The rate of perfusion is approximately 30 mL/hr. As can be seen from FIG. **32**, the levels of various electrolytes: sodium, potassium, calcium, and chloride ions, as well as dissolved glucose, remain at stable levels throughout the course of perfusion, from before the organ is cannulated to the perfusion system **100** to six

hours after cannulation. FIG. 32 also demonstrates that the levels of the electrolytes and glucose remain at levels similar to those for the base line (BL) normal physiological state for the organ.

[0278] FIG. 33 depicts a chart demonstrating the arterial blood gas profile for an organ under going perfusion according to another embodiment of the invention. As can be seen from FIG. 33, the levels of various blood gasses: carbon dioxide and oxygen, and pH remain at stable levels throughout the six hour course of perfusion. FIG. 33 also demonstrates that the levels of carbon dioxide, oxygen, and pH remain at levels similar to those for two base line (BL) measurements for the normal physiological state for the organ. FIGS. 31-33 demonstrate the ability of the present systems and methods to maintain an organ under stable physiological or near physiological conditions.

[0279] It is to be understood that while the invention has been described in conjunction with the various illustrative embodiments, the forgoing description is intended to illustrate and not limit the scope of the invention, which is defined by the scope of the appended claims. For example, a variety of systems and/or methods may be implemented based on the disclosure and still fall within the scope of the invention. Other aspects, advantages, and modifications are within the scope of the following claims. All references cited herein are incorporated by reference in their entirety and made part of this application.

1-33. (canceled)

34. A method comprising:

- placing an ex-vivo organ in a chamber of an organ care system;
- connecting the ex-vivo organ to a perfusion fluid circuit of the organ care system;
- initiating a pumping, via the perfusion fluid circuit, of a perfusion fluid to the ex-vivo organ;
- testing the ex-vivo organ or the organ care system;
- adjusting a property of the organ care system in response to a result of the testing the ex-vivo organ or the organ care system; and
- after adjusting the property of the organ care system in response to the result of the testing the ex-vivo organ or the organ care system, re-testing the ex-vivo organ or the organ care system.

35. The method of claim 34, wherein the testing comprises performing, on the ex-vivo organ, an ultrasound, an echocardiogram, a blood chemistry analysis, a pressure volume loop evaluation, or a Millar pressure evaluation.

36. The method of claim 35, wherein performing, on the ex-vivo organ, the blood chemistry analysis comprises measuring, in the perfusion fluid, a carbon dioxide level, an oxygen level, or a pH level.

37. The method of claim 34, wherein the testing comprises:

- opening an outer lid of the chamber of the organ care system; and
- examining the ex-vivo organ through a flexible membrane.

38. The method of claim 34, wherein adjusting the property of the organ care system comprises selecting the property of the organ care system from the group consisting of a fluid-flow rate of the perfusion fluid, a pressure of the perfusion fluid, a temperature of the perfusion fluid, an oxygenation level of the perfusion fluid, or a nutrition level of the perfusion fluid.

39. The method of claim 34, wherein adjusting the property of the organ care system comprises applying a defibrillation signal to the ex-vivo organ.

40. The method of claim 34, comprising:

- after re-testing the ex-vivo organ or the organ care system,
- evaluating the ex-vivo organ for compatibility with an intended recipient.

41. The method of claim 40, wherein evaluating the ex-vivo organ for compatibility with the intended recipient comprises performing, while the ex-vivo organ is connected to the organ care system, a Human Leukocyte Antigen (HLA) matching test on the ex-vivo organ.

42. The method of claim 34, comprising:

- performing, while the ex-vivo organ is connected to the organ care system, a surgical procedure on the ex-vivo organ.

43. The method of claim 34, comprising:

- providing, to the ex-vivo organ, an immunosuppressive treatment, a chemotherapy treatment, a genetic therapy, or an irradiation therapy.

44. The method of claim 34, comprising:

- allowing the ex-vivo organ to remain connected to the perfusion fluid circuit for at least three days.

45. The method of claim 34, comprising:

- after adjusting the property of the organ care system in response to the result of the testing, initiating a pumping of the perfusion fluid in a retrograde flow direction.

46. The method of claim 34, comprising:

- slowing or stopping a retrograde flow of the perfusion fluid; and
- after slowing or stopping the retrograde flow of the perfusion fluid, initiating a pumping of the perfusion fluid in a forward direction.

47. The method of claim 46, wherein initiating the pumping of the perfusion fluid in the forward direction comprises initiating the pumping of the perfusion fluid in the forward direction at a flow rate between about 1 Liter/minute and about 5 Liters/minute.

48. A method comprising:

- receiving an ex-vivo organ in a chamber of an organ care system;
- pumping, via a perfusion fluid circuit of the organ care system, a perfusion fluid to the ex-vivo organ, wherein the ex-vivo organ is connected to the perfusion fluid circuit;

allowing for testing of the ex-vivo organ or the organ care system;

receiving an adjustment of a property of the organ care system in response to a result of the testing of the ex-vivo organ or the organ care system; and

after receiving the adjustment of the property of the organ care system in response to the result of the testing of the ex-vivo organ or the organ care system, allowing for re-testing of the ex-vivo organ or the organ care system.

49. The method of claim 48, wherein allowing for testing of the ex-vivo organ or the organ care system comprises allowing for measuring, with respect to the ex-vivo organ, of an electrocardiogram signal, a hematocrit saturation level, an oxygen saturation level, an arterial blood gas level, a metabolite level, or an electrolyte level.

50. The method of claim 48, wherein allowing for testing comprises allowing for measuring a fluid flow rate of the perfusion fluid, a pressure of the perfusion fluid, or a temperature of the perfusion fluid.

51. The method of claim **48**, wherein allowing for testing comprises allowing for performing, on the ex-vivo organ, an echocardiogram or a blood chemistry analysis.

52. The method of claim **48**, wherein receiving the adjustment of the property of the organ care system comprises receiving an application of a defibrillation signal to the ex-vivo organ.

53. The method of claim **48**, comprising:
after receiving the adjustment of the property of the organ care system in response to the result of the testing, pumping the perfusion fluid in a retrograde flow direction.

54. The method of claim **48**, comprising:
slowing or stopping a retrograde flow of the perfusion fluid; and
after slowing or stopping the retrograde flow of the perfusion fluid, pumping the perfusion fluid in a forward direction.

55. The method of claim **54**, wherein pumping the perfusion fluid in the forward direction comprises pumping the perfusion fluid in the forward direction at a flow rate between about 1 Liter/minute and about 5 Liters/minute.

56. An organ care system comprising:
a chassis; and
a perfusion fluid circuit,
wherein the organ care system is configured to:
pump a perfusion fluid through the perfusion fluid circuit;
allow for testing of an ex-vivo organ or of the organ care system; and
receive an adjustment of a property of the organ care system in response to a result of the testing of the ex-vivo organ or of the organ care system.

57. The organ care system of claim **56**, wherein the organ care system comprises a sensor configured to measure, with respect to the ex-vivo organ, an electrocardiogram signal, a hematocrit saturation level, an oxygen saturation level, an arterial blood gas level, a metabolite level, or an electrolyte level.

58. The organ care system of claim **56**, wherein the organ care system comprises a sensor configured to measure, in the perfusion fluid, a carbon dioxide level, an oxygen level, or a pH level.

59. The organ care system of claim **56**, wherein the organ care system comprises an outer lid operatively connected to the chassis, and wherein the outer lid is configured to open to allow examining the ex-vivo organ through a flexible membrane.

60. The organ care system of claim **56**, wherein the property of the organ care system is one of a fluid flow rate of the perfusion fluid, a pressure of the perfusion fluid, a temperature of the perfusion fluid, an oxygenation level of the perfusion fluid, or a nutrition level of the perfusion fluid.

61. The organ care system of claim **56**, wherein the organ care system is configured to allow the ex-vivo organ to be connected to the organ care system for at least three days.

62. The organ care system of claim **56**, wherein the organ care system is configured to pump the perfusion fluid in a retrograde flow direction.

63. The organ care system of claim **62**, wherein the organ care system is configured to:
slow or stop a retrograde flow of the perfusion fluid; and
pump the perfusion fluid in a forward direction.

* * * * *