



(19) **United States**
(12) **Patent Application Publication**
Madhani et al.

(10) **Pub. No.: US 2010/0292708 A1**
(43) **Pub. Date: Nov. 18, 2010**

(54) **ARTICULATED SURGICAL INSTRUMENT FOR PERFORMING MINIMALLY INVASIVE SURGERY WITH ENHANCED DEXTERITY AND SENSITIVITY**

(75) Inventors: **Akhil J. Madhani**, Glendale, CA (US); **J. Kenneth Salisbury**, Mountain View, CA (US)

Correspondence Address:
PATENT DEPT
INTUITIVE SURGICAL OPERATIONS, INC
1266 KIFER RD, BUILDING 101
SUNNYVALE, CA 94086 (US)

(73) Assignee: **Intuitive Surgical Operations, Inc.**, Sunnyvale, CA (US)

(21) Appl. No.: **12/833,766**

(22) Filed: **Jul. 9, 2010**

Related U.S. Application Data

(63) Continuation of application No. 11/945,424, filed on Nov. 27, 2007, now Pat. No. 7,780,651, which is a continuation of application No. 11/243,730, filed on Oct. 4, 2005, now Pat. No. 7,316,681, which is a continuation of application No. 10/076,812, filed on Feb.

15, 2002, now Pat. No. 6,991,627, which is a continuation of application No. 09/340,946, filed on Jun. 28, 1999, now Pat. No. 6,371,952, which is a continuation of application No. 09/030,661, filed on Feb. 25, 1998, now Pat. No. 5,976,122, which is a continuation of application No. 08/857,776, filed on May 16, 1997, now Pat. No. 5,792,135.

(60) Provisional application No. 60/017,981, filed on May 20, 1996.

Publication Classification

(51) **Int. Cl.**
A61B 19/00 (2006.01)
A61B 17/94 (2006.01)

(52) **U.S. Cl.** **606/130**

(57) **ABSTRACT**

An articulated surgical instrument for enhancing the performance of minimally invasive surgical procedures. The instrument has a high degree of dexterity, low friction, low inertia and good force reflection. A unique cable and pulley drive system operates to reduce friction and enhance force reflection. A unique wrist mechanism operates to enhance surgical dexterity compared to standard laparoscopic instruments. The system is optimized to reduce the number of actuators required and thus produce a fully functional articulated surgical instrument of minimum size.

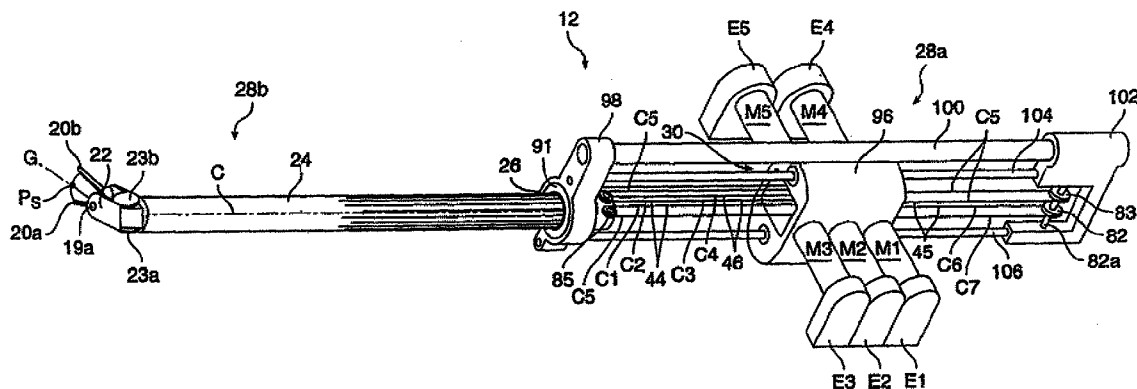

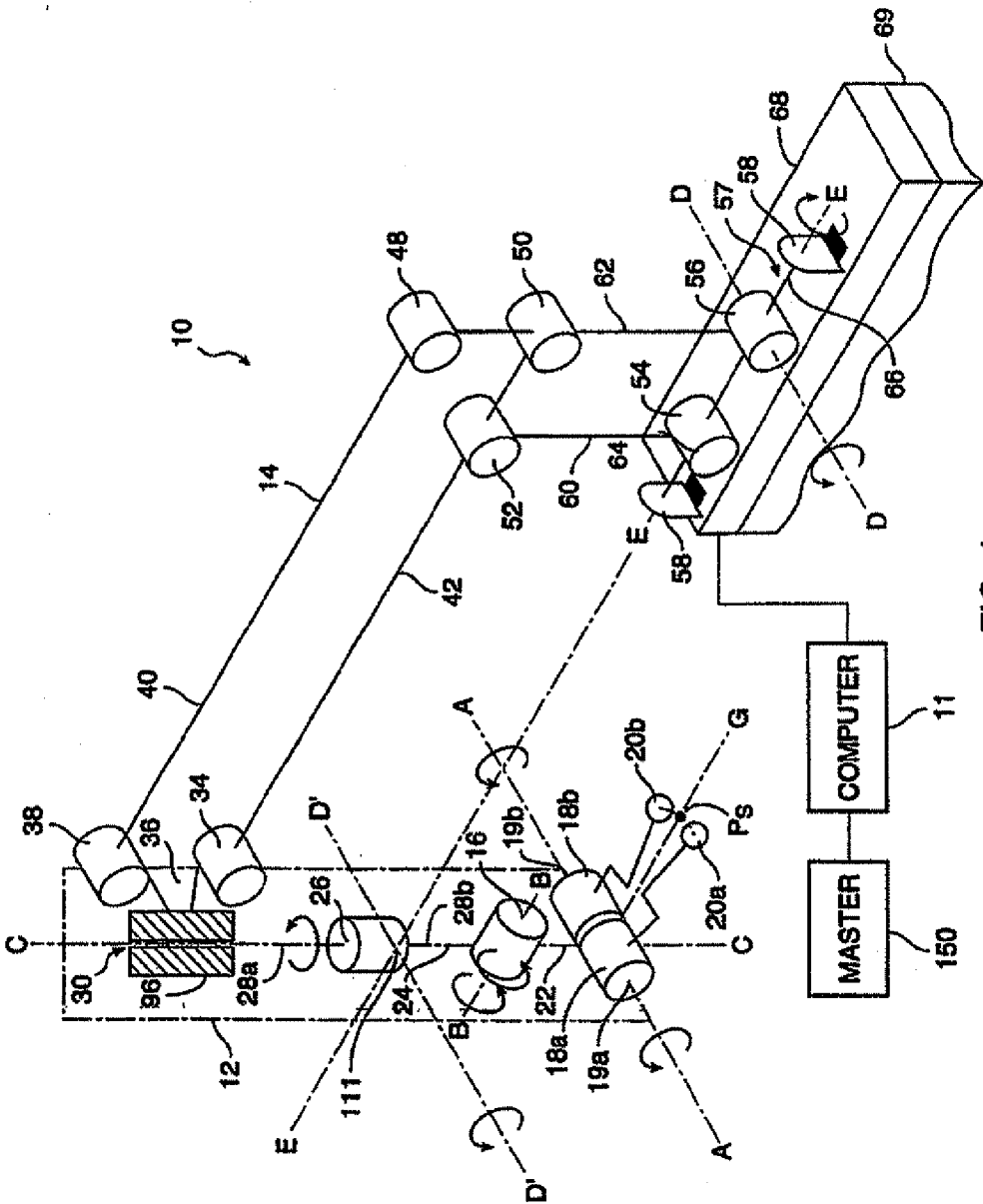

FIG. 1

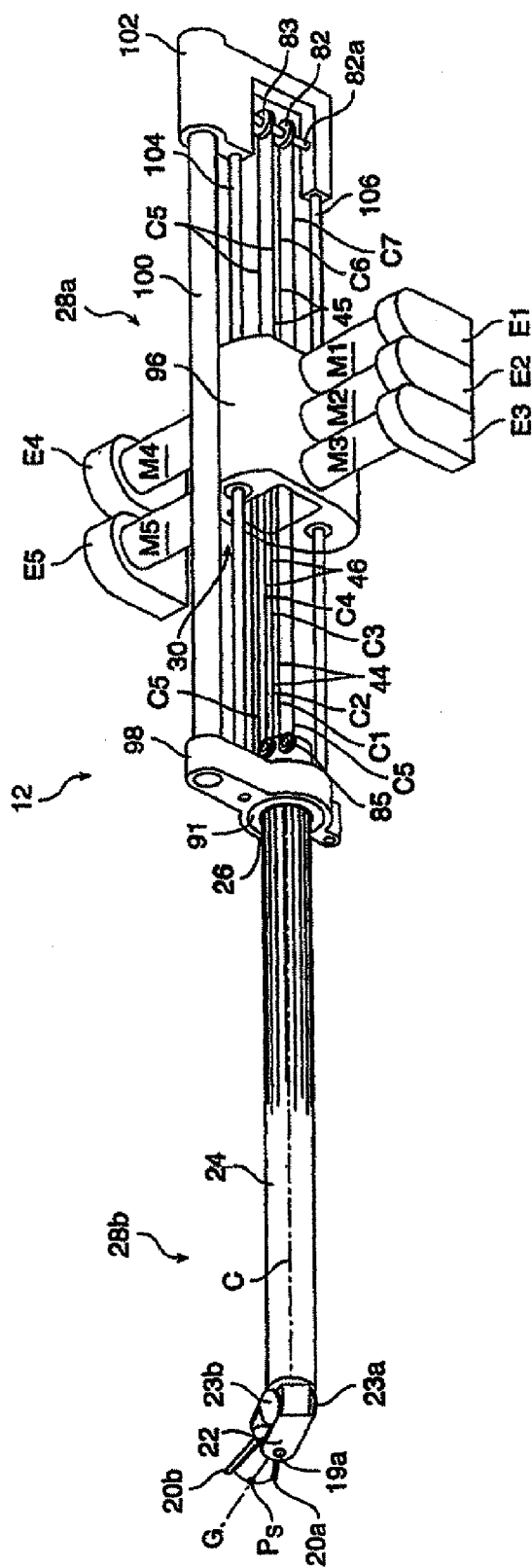

FIG. 3

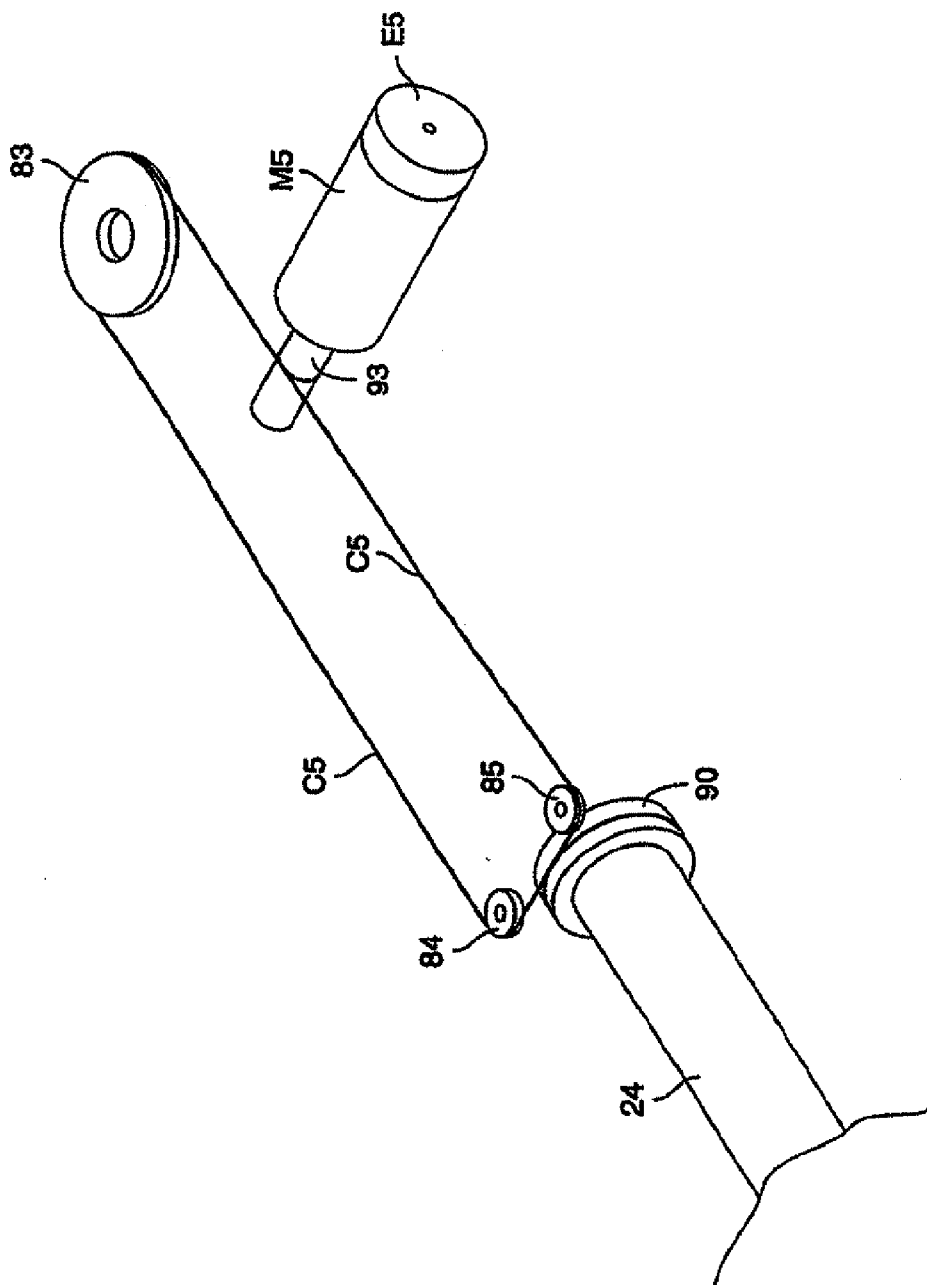

FIG. 4

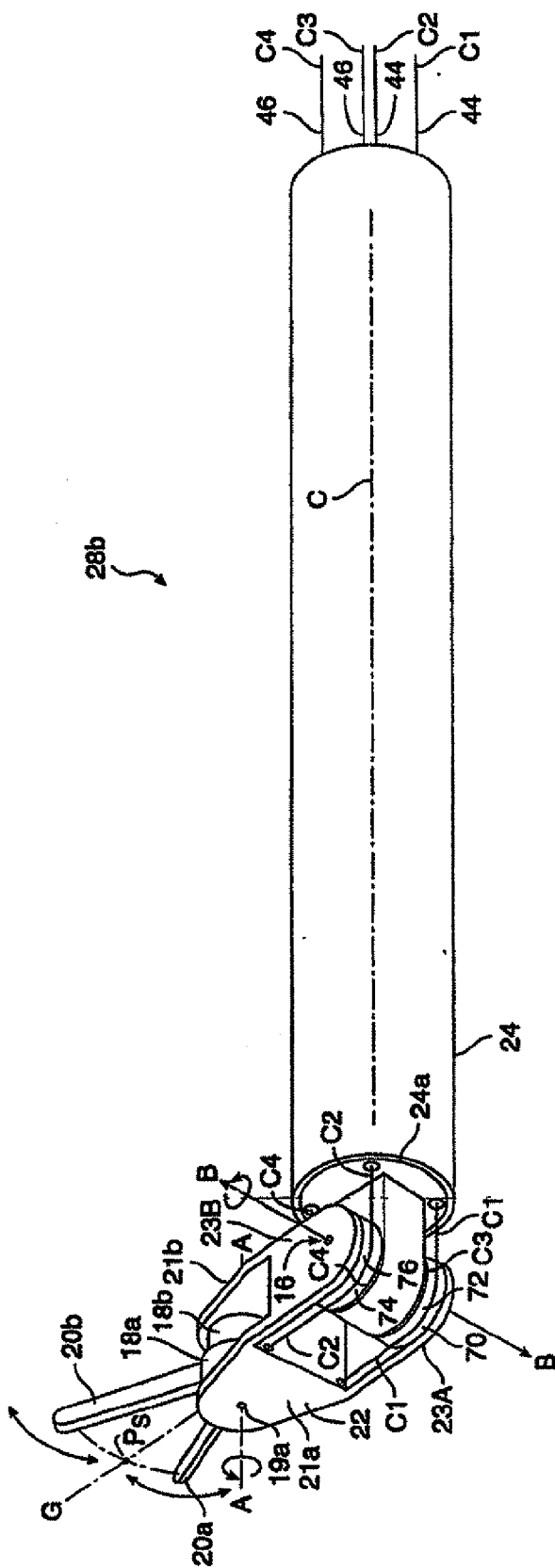

FIG. 5

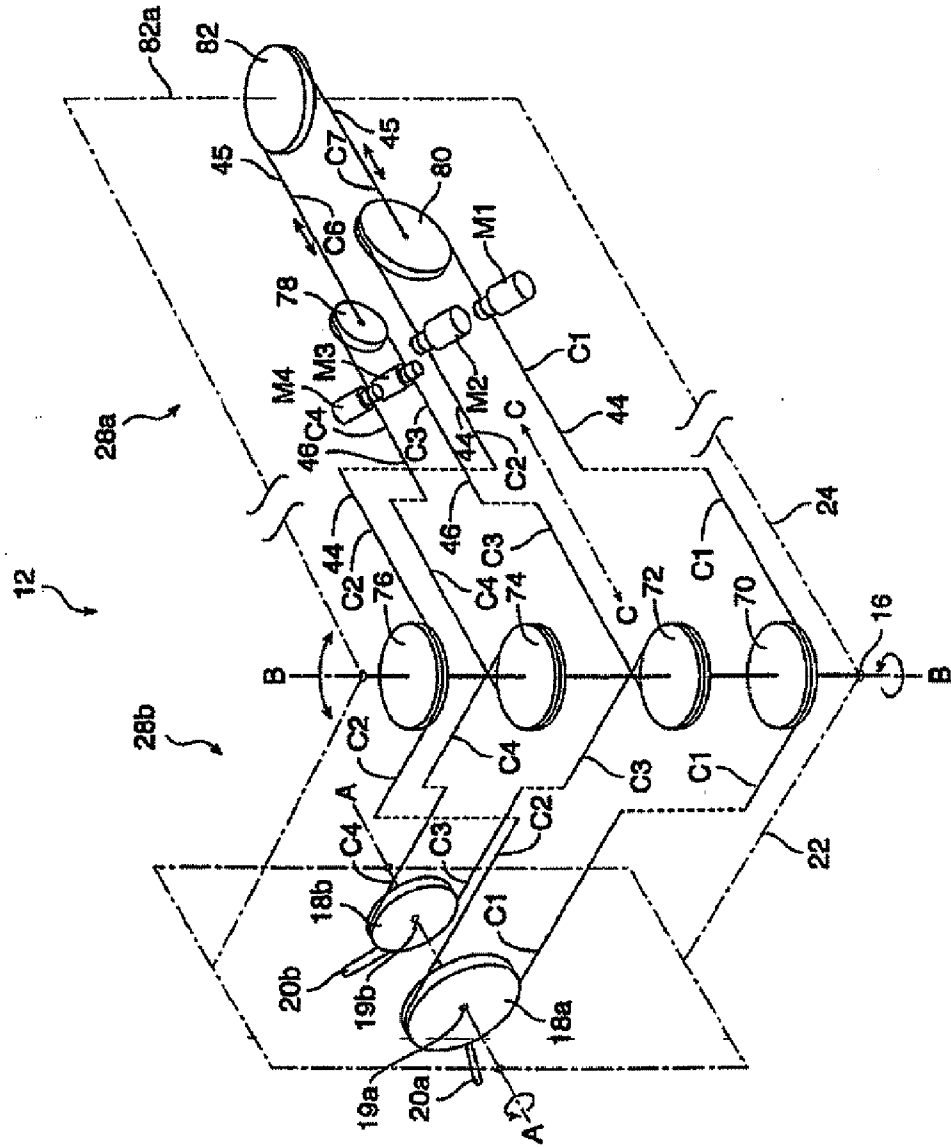

FIG. 6

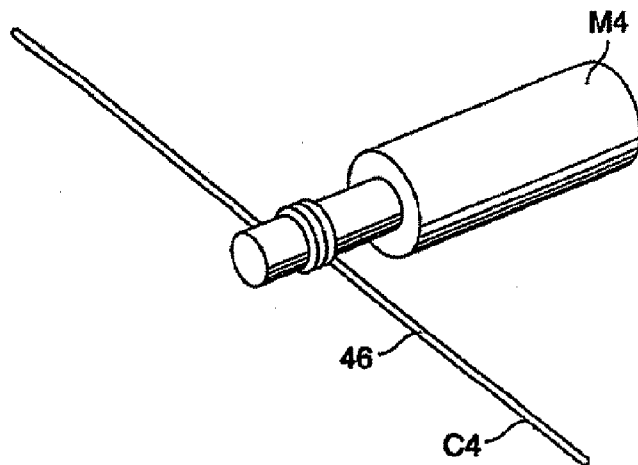

FIG. 7A

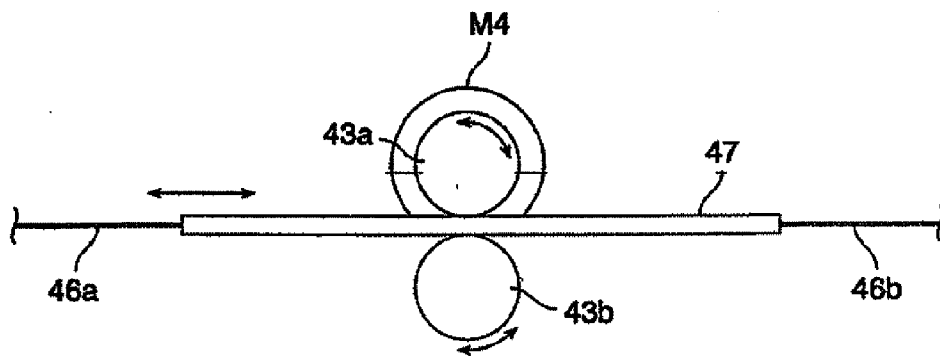

FIG. 7B

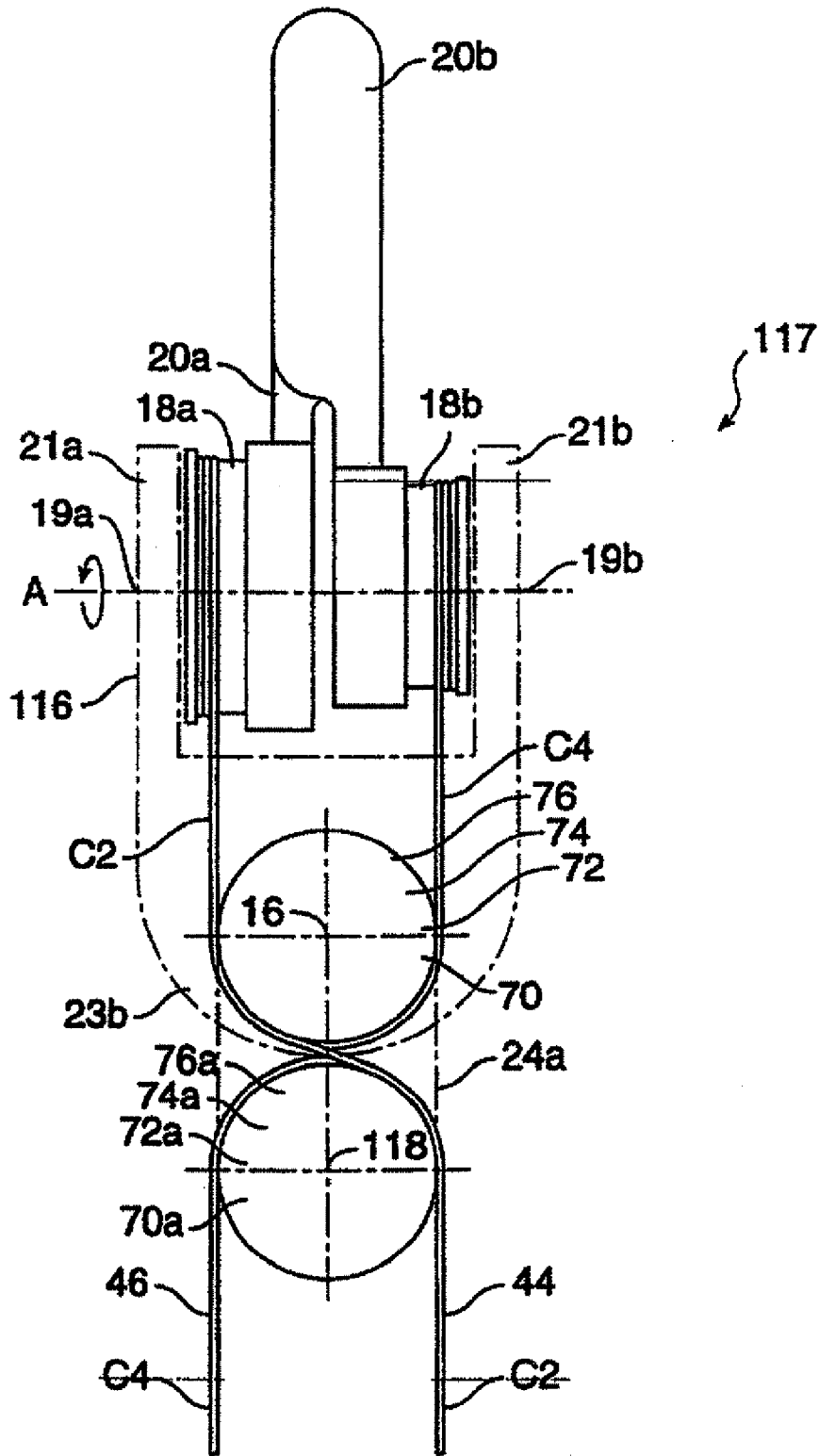

FIG. 8

**ARTICULATED SURGICAL INSTRUMENT
FOR PERFORMING MINIMALLY INVASIVE
SURGERY WITH ENHANCED DEXTERITY
AND SENSITIVITY**

[0001] This application is a continuation of, and claims the benefit of priority from, co-pending U.S. patent application Ser. No. 10/076,812, filed Feb. 15, 2002, which is a continuation of Ser. No. 09/340,946, filed Jun. 28, 1999, which is a continuation of U.S. patent application Ser. No. 09/030,661, filed Feb. 25, 1998 (now U.S. Pat. No. 5,976,122), which is a continuation of U.S. patent application Ser. No. 08/857,776, filed May 16, 1997 (now U.S. Pat. No. 5,792,135), which claims priority to U.S. Provisional Application No. 60/017,981, filed May 20, 1996, the full disclosures of which are incorporated herein by reference.

FIELD OF THE INVENTION

[0002] This invention relates generally to methods and apparatus for enhancing the performance of minimally invasive surgery. This invention relates particularly to surgical instruments that augment a surgeon's ability to perform minimally invasive surgical procedures. This invention relates more particularly to a novel articulated surgical instrument for minimally invasive surgery which provides a high degree of dexterity, low friction, low inertia and good force reflection.

BACKGROUND OF THE INVENTION

[0003] Minimally invasive medical techniques are aimed at reducing the amount of extraneous tissue which must be damaged during diagnostic or surgical procedures, thereby reducing patient recovery time, discomfort, and deleterious side effects. Approximately 21,000,000 surgeries are now performed each year in the United States. It is estimated that 8,000,000 of these surgeries can potentially be performed in a minimally invasive manner. However, only about 1,000,000 surgeries currently use these techniques due to limitations in minimally invasive surgical instruments and techniques and the additional surgical training required to master them.

[0004] Advances in minimally invasive surgical technology could have a dramatic impact. The average length of a hospital stay for a standard surgery is 8 days, while the average length for the equivalent minimally invasive surgery is 4 days. Thus, the complete adoption of minimally invasive techniques could save 28,000,000 hospital days, and billions of dollars annually in hospital residency costs alone. Patient recovery times, patient discomfort, surgical side effects, and time away from work are also reduced with minimally invasive surgery.

[0005] The most common form of minimally invasive surgery is endoscopy. Probably the most common form of endoscopy is laparoscopy which is minimally-invasive inspection and surgery inside the abdominal cavity. In standard laparoscopic surgery, a patient's abdomen is insufflated with gas, and cannula sleeves are passed through small (approximately ½ inch) incisions to provide entry ports for laparoscopic surgical instruments.

[0006] The laparoscopic surgical instruments generally include a laparoscope for viewing the surgical field, and working tools such as clamps, graspers, scissors, staplers, and needle holders. The working tools are similar to those used in

conventional (open) surgery, except that the working end of each tool is separated from its handle by an approximately 12-inch long extension tube.

[0007] To perform surgical procedures, the surgeon passes instruments through the cannula and manipulates them inside the abdomen by sliding them in and out through the cannula, rotating them in the cannula, levering (i.e., pivoting) the instruments in the abdominal wall and actuating end effectors on the distal end of the instruments. The instruments pivot around centers of rotation approximately defined by the incisions in the muscles of the abdominal wall. The surgeon monitors the procedure by means of a television monitor which displays the abdominal worksite image provided by the laparoscopic camera.

[0008] Similar endoscopic techniques are employed in arthroscopy, retroperitoneoscopy, pelviscopy, nephroscopy, cystoscopy, cisternoscopia, sinoscopy, hysteroscopy and urethroscopy. The common feature of all of these minimally invasive surgical techniques is that they visualize a worksite within the human body and pass specially designed surgical instruments through natural orifices or small incisions to the worksite to manipulate human tissues and organs thus avoiding the collateral trauma caused to surrounding tissues which would result from creating open surgical access.

[0009] There are many disadvantages of current minimally invasive surgical technology. For example, existing MIS instruments deny the surgeon the flexibility of tool placement found in open surgery. Most laparoscopic tools have rigid shafts and are constrained to approach the worksite from the direction of the small incision. Additionally, the length and construction of many endoscopic instruments reduces the surgeon's ability to feel forces exerted by tissues and organs on the end effector of the tool. The lack of dexterity and sensitivity provided by endoscopic tools is a major impediment to the expansion of minimally invasive surgery.

[0010] Telesurgery systems for use in surgery are being developed to increase a surgeon's dexterity as well as to allow a surgeon to operate on a patient from a remote location. Telesurgery is a general term for surgical systems where the surgeon uses some form of servomechanism to manipulate the surgical instruments movements rather than directly holding and moving the tools. In a system for telesurgery, the surgeon is provided with an image of the patient's body at the remote location. While viewing the three-dimensional image, the surgeon performs the surgical procedures on the patient by manipulating a master device which controls the motion of a servomechanism-actuated instrument. The surgeon's hands and the master device are positioned relative to the image of the operation site in the same orientation as the instrument is positioned relative to the act. During the operation, the instrument provides mechanical actuation and control of a variety of surgical instruments, such as tissue graspers, needle drivers, etc., that each perform various functions for the surgeon, i.e., holding or driving a needle, grasping a blood vessel or dissecting tissue.

[0011] Such telesurgery systems have been proposed for both open and endoscopic procedures. An overview of the state of the art with respect to telesurgery technology can be found in "Computer Integrated Surgery Technology And Clinical Applications" (MIT Press, 1996). Moreover, prior systems for telesurgery are described in U.S. Pat. Nos. 5,417,210, 5,402,801, 5,397,323, 5,445,166, 5,279,309, 5,299,288.

[0012] However methods of performing telesurgery using telemanipulators still require the development of dexterous

surgical instruments capable of transmitting position, force, and tactile sensations from the surgical instrument back to the surgeon's hands as he/she operates the telesurgery system such that the system the surgeon has the same feeling as if manipulating the surgical instruments directly by hand. A system's ability to provide force reflection is limited by factors such as friction within the mechanisms, gravity, the inertia of the surgical instrument and forces exerted on the instrument at the surgical incision.

[0013] What is needed, therefore, is a surgical instrument that increases the dexterity with which a surgeon can perform minimally invasive surgical procedures.

[0014] It would also be desirable to provide a dexterous surgical apparatus having a wrist with two degrees-of-freedom.

[0015] It would further be desirable to provide a wrist mechanism that has low friction in order to provide the surgeon with sensitive feedback of forces exerted on the surgical instrument.

[0016] It would still further be desirable to provide a surgical instrument having a wrist mechanism for minimally invasive surgery which is suitable for operation in a telemanipulator mechanism.

SUMMARY AND OBJECTS OF THE INVENTION

[0017] Accordingly, it is an object of this invention to provide a surgical instrument that increases the dexterity with which a surgeon can perform minimally invasive surgical procedures.

[0018] It is also an object of this invention to provide a dexterous surgical apparatus having a wrist with two degrees-of-freedom.

[0019] It is a further object of this invention to provide a wrist mechanism that has low friction in order to provide the surgeon with sensitive feedback of forces exerted on the surgical instrument.

[0020] It is a still further object of this invention to provide a surgical instrument having a wrist mechanism for minimally invasive surgery which is suitable for, operation in a telemanipulator mechanism.

[0021] In accordance with the above objects of the invention applicants describe a compact articulated surgical instrument suitable for endoscopic surgery. The instrument has two opposed pivoting jaws and a pivoting wrist member. The instrument is capable of providing force reflection with high sensitivity. The instrument is adapted to be coupled via a servomechanism to a master control operated by a surgeon.

BRIEF DESCRIPTION OF THE DRAWINGS

[0022] The foregoing and other objects, features and advantages of the invention will be apparent from the following more particular description of preferred embodiments of the drawings in which like reference characters refer to the same parts throughout the different views. The drawings are not necessarily to scale, emphasis instead being placed upon illustrating the principles of the invention.

[0023] FIG. 1 is a schematic drawing of a servomechanical surgery system including a force-reflecting surgical instrument mounted to a positioning mechanism.

[0024] FIG. 2 is a schematic drawing of a positioning mechanism in forward and rearward positions with the surgical instrument inserted into a patient.

[0025] FIG. 3 is a perspective view of a force-reflecting surgical instrument.

[0026] FIG. 4 is a schematic view of the cable drive actuation of the rotary motion of the force-reflecting surgical instrument.

[0027] FIG. 5 is a perspective view of the distal end of the force-reflecting surgical instrument.

[0028] FIG. 6 is a simplified schematic drawing of the force-reflecting surgical instrument showing the relationship of the cables and pulleys.

[0029] FIG. 7a is a perspective view of a cable wrapped around the drive shaft of a drive motor.

[0030] FIG. 7b is a schematic drawing showing another preferred method for driving the cables in the present invention.

[0031] FIG. 8 is a top view of the wrist member of another preferred force-reflecting surgical instrument.

DETAILED DESCRIPTION OF THE PREFERRED EMBODIMENTS

[0032] The surgical instrument in the first embodiment includes an elongate support member having a proximal portion and a distal portion lying along a longitudinal axis. A distal wrist member is rotatably coupled to the distal portion of the support member by a wrist joint. First and second opposed work members are mounted to respective first and second driven capstans. The first and second driven capstans are rotatably mounted to the wrist member by respective first and second capstan joints which preferably have a common axis. First, second, third and fourth intermediate idler pulleys are rotatably mounted to the wrist member about the wrist joint. A cable drive system including first, second, third and fourth cables is provided. Each intermediate idler pulley is engaged by one cable and each driven capstan is drivingly engaged by two cables. The cable drive system is capable of pivoting the wrist member about the wrist joint and pivoting the work members independently of each other about the capstan joints.

[0033] In preferred embodiments, a linear bearing is mounted in sliding engagement with the support member for allowing the distal portion of the support member to be reciprocated along the longitudinal axis relative to the proximal portion of the support member. In such embodiments the cable drive system is capable of translating the support member along the longitudinal axis. In preferred embodiments, the support member may also include a rotary joint separating the proximal and distal portions of the support member for allowing rotation of the distal portion relative to the proximal portion about the longitudinal axis. In such embodiments the first through fourth cables are capable of twisting about the longitudinal axis during rotation of the distal portion and the cable drive system comprises a fifth cable coupled to the rotary joint for rotating the distal portion about the longitudinal axis.

[0034] The present invention also provides a novel system for tensioning the first, second, third and fourth cables. A first proximal idler pulley rotatably engages and tensions the first and second cables. A second proximal idler pulley rotatably engages and tensions the third and fourth cables. Fifth and sixth cables are connected to the first and second proximal idler pulleys for tensioning the first and second proximal idler pulleys. A third more proximal idler pulley is rotatably mounted to a support member for rotatably engaging and tensioning the fifth and sixth cables.

[0035] The surgical instrument further includes a plurality of actuators, each for driving one of the cables of the cable drive system. The instrument preferably comprises one actuator for each degree-of-freedom of the instrument. The actuators are preferably servomotors which are positioned between the intermediate idler pulleys and the proximal idler pulleys. The servomotors are preferably directly coupled to the cables by means of a drive capstan mounted on the drive shaft of the servomotor.

[0036] The surgical instrument is adapted to be a slave device which is controlled by a master device and a controller. Movements of the instrument and the master device as well as forces exerted thereon may be scaled between the instrument and the master device. A positioning mechanism having two degrees-of-freedom may be mounted to the instrument for positioning the instrument over a work site. The positioning mechanism may provide the instrument with redundant degrees-of-freedom for positioning the endpoint. The combination of a positioning mechanism with the applicants articulated surgical instrument is adapted to enable a surgeon operating the master device to feel forces that are experienced by the instrument during positioning and use of the instrument with greater sensitivity than with prior systems.

[0037] Details about the preferred attributes of the surgical system are also described in applicants' copending applications titled "Force-Reflecting Surgical Instrument And Positioning Mechanism For Performing Minimally Invasive Surgery With Enhanced Dexterity And Sensitivity" and "Wrist Mechanism For Surgical Instrument For Performing Minimally Invasive Surgery With Enhanced Dexterity And Sensitivity" filed on even date herewith. The disclosures of these applications are incorporated herein by reference.

[0038] Referring to FIG. 1, telesurgery system 10 allows a surgeon at one location to perform surgery on a patient at another location. The surgeon may be in the same operating room as the patient or many miles away. Telesurgery system 10 includes a force-reflecting surgical instrument 12 which is mounted by a bracket 36 to a positioning mechanism 14. Instrument 12 and positioning mechanism 14 are controlled by a computer 11 and a master device 150 which is manipulated by a surgeon at a remote location. Instrument 12 and positioning mechanism 14 are driven by drive motors M1, M2, M3, M4, M5, M6 and M7 (FIGS. 3, 4, 6 and 7a-b) in conjunction with a series of cables and pulleys.

[0039] Instrument 12 has low friction, low inertia and high bandwidth but a small range of motion. Positioning mechanism 14 has a large range of motion but typically has a higher inertia and a lower bandwidth than the instrument. The combination of instrument 12 and positioning mechanism 14 in a macro/micro actuation scheme results in a system with increased dynamic range compared to either of its individual components. Positioning mechanism 14 provides telesurgery system 10 with redundant degrees-of-freedom and helps position instrument 12 at a surgical worksite so that instrument 12 is generally in the proper location for performing the necessary surgery. Thus, by mounting instrument 12 on positioning mechanism 14, telesurgery system 10 is provided with high quality force control through the use of instrument 12 while at the same time having a large range of motion due to positioning mechanism 14. Instrument 12 is mounted on positioning mechanism 14 by means of mounting bracket 36. Preferably, the Instrument 12 is releasably attached to positioning mechanism 14 using any suitable releasable attachment means such as screws, bolts, clamps.

[0040] Instrument 12 has a proximal portion 28a which is rotatably coupled to a distal portion 28b by a rotary joint 26. Proximal portion 28a is slidably coupled to a sliding bracket 96 which forms a sliding joint 30. Sliding bracket 96 is fixed to bracket 36. Bracket 36 is a mounting bracket which releasably connects instrument 12 to positioning mechanism 14. Distal portion 28b of instrument 12 includes a wrist member which is rotatably coupled to a tubular support member 24 by a wrist joint 16. Two opposed work members 20a and 20b are fixed to respective driven capstans 18a and 18b which are rotatably coupled to wrist member 22 about capstan joints 19a and 19b. The work members 20a and 20b can be the operative end of standard surgical instruments such as scissors, retractors, needle drivers and electrocautery instruments.

[0041] Instrument 12 has five degrees-of-freedom with sliding joint 30 providing linear motion along longitudinal axis C-C, rotary joint 26 providing rotational motion about axis C-C, wrist joint 16 providing rotational motion about axis B-B and capstan joints 19a and 19b providing rotational motion about axis A-A for work members 20a and 20b. Instrument 12 provides master device 150 with four degrees of force reflection so that the surgeon can have tactile feedback of surgical procedures. These degrees of force reflection include x, y and z forces exerted on the work members 20a and 20b, as well as the holding force between work members 20a and 20b. However, force reflection can be provided on more or fewer motion axes as required in any particular embodiment.

[0042] Positioning mechanism 14 is a two degree-of-freedom linkage which is preferably a four bar linkage which rotates about an axis E-E. Positioning mechanism 14 has a series of rigid members 36, 40, 42, 60 and 62 which are joined together by joints 34, 38, 48, 50, 52, 54, 56. Positioning mechanism 14 also includes a base 68 having ears 58 which engage shafts 64 and 66 to form a joint 57 for pivoting about axis E-E. Joint 56 allows link 62 to rotate about axis D-D which is orthogonal to axis E-E. The four bar linkage of rigid members 36, 40, 42, 60 and 62 transmits this rotation to instrument 12 via bracket 36 causing instrument 12 to rotate about axis E-E and axis D'-D' (axis D'-D' is parallel to axis D-D and intersects axis E-E orthogonally). Thus the four bar linkage operates to move point P.sub.s of instrument 12 about the surface of a sphere having its center at a remote center 111. Although a four bar linkage has been shown, the articulated surgical instrument of the present invention can be supported by any suitable positioning mechanism. To be suitable for minimally invasive surgery the positioning mechanism must pivot the surgical instrument about axes that intersect at the orifice through which the instrument is inserted into the patient.

[0043] Haptic master device 150 suitable to control instrument 12 is a seven degree-of-freedom input device. During use the master 150 is fixed in place to a console or cart or similar stationary support such that the mount provides a fixed reference point. During use, the surgeon manipulates the position and orientation of the master mechanism relative to its stationary support. Linkages, motors and encoders of the master detect the surgeon's movements and transmit them to the computer. The motors of the master preferably also provide force feedback to the surgeon. This controls motions of instrument 12 and positioning mechanism 14 and thus controls the position of the distal end of instrument 12 relative to the surgical site.

[0044] One apparatus suitable for use as a master in the presently described system is described in U.S. Pat. No. 5,587,937, titled Force Reflecting Haptic Interface the contents of which are incorporated by reference herein. Another suitable master device is described in U.S. Pat. No. 5,576,727, titled Electromechanical Human-Computer Interface With Force-Feedback the contents of which are incorporated by reference herein. The haptic master apparatus disclosed in the above references would require the addition of a further powered degree-of-freedom to provide force reflection from gripping the work members. For example, finger grippers may be attached to a motor and encoder on a separate mechanism for operation by the other hand of the surgeon. Alternatively, finger grippers may be attached to a motor and encoder on the same device for operation by the surgeon.

[0045] When employing telesurgery system 10 for laparoscopic surgery, positioning mechanism 14 is mounted to a manually-operated setup joint (not shown). After the setup joint has been used to position the tool and lock the tool in place, the surgeon then manipulates master device 150 to move instrument 12 through a cannula 113 inserted through small incision 112 in the abdominal wall 110 of the patient. In response to manipulation of master device 150, the distal portion 28b of the instrument 12 is translated downwardly relative to positioning mechanism 14 along sliding joint 30 for insertion through cannula 113 and abdominal wall 110.

[0046] Once within the abdomen, the distal portion 28b of instrument 12 is further positioned over the desired surgical site. FIG. 2 depicts motion of mechanism 14 pivoted about axis D-D in forward and rearward positions for making large position movements. Positioning mechanism 14 pivots about axes D-D and E-E to perform large movements of telesurgery system 10 while precise movements are made by the joints of instrument 12. Point 111 on instrument 12 is a remote point of rotation from positioning mechanism 14 which coincides with entry wound 112. When positioning mechanism 14 is pivoted about axes D and E, instrument 12 pivots about point 111. Note that point 111 adjacent incision 112 remains stationary as the instrument 12 is pivoted within the patient. As a result, incision 112 only needs to be large enough to accept instrument 12.

[0047] As positioning mechanism 14 pivots, if wrist member 22 or work members 20a/20b engage tissue causing rotation about joints 16 or 19a/19b, instrument 12 will reorient itself so that instrument 12 is maintained relative to positioning mechanism 14 in the middle of its workspace. If necessary, positioning mechanism 14 can slow down as instrument 12 is reorienting itself.

[0048] Once instrument 12 is in the proper position, by further manipulating master device 150, the surgeon can perform the necessary surgical procedures on the patient with instrument 12. Forces experienced by instrument 12 are reflected back to the surgeon by master device 150. The reflected forces may be scaled up in order to allow the surgeon to better "feel" the surgical procedures. As a result, the surgeon can feel instrument 12 engaging types of tissue that do not provide much resistance. In addition, movements of master device 150 relative to instrument 12 may be scaled down so that the precision and dexterity of instrument 12 can be increased.

[0049] Positioning mechanism 14, because it is optimized to have a large range of motion, is likely to have higher inertia, higher friction and lower resolution than instrument 12.

Moreover, friction forces in cannula 113 and disturbance forces at incision 112 may be applied to the positioning mechanism.

[0050] However, in applicants' preferred embodiment, primarily the surgical instrument detects forces for force reflection. Therefore, the higher inertia and friction of the positioning mechanism and the extraneous forces acting on it are excluded from the force reflection system. Thus, the quality of the force reflection between the tip of the instrument 12 and the master device is greatly improved.

[0051] Referring to FIGS. 3, 4 and 5, instrument 12 is now described in greater detail. Tubular support member 24 of distal portion lies along axis C-C and houses a series of cables C1, C2, C3 and C4 which travel the length of tubular support member 24. Cables C1, C2, C3 and C4 control the rotation of joints 19a, 19b and 16 for controlling the operation of work members 20a and 20b and the orientation of wrist member 22. Wrist member 22 includes two opposed distal ears 21a and 21b forming a clevis for supporting driven capstans 18a and 18b at respective capstan joints 19a and 19b which lie along axis A-A. Wrist member 22 also includes two opposed proximal ears 23a and 23b forming a clevis for supporting intermediate idler pulleys 70 and 72 which lie along axis B-B between ear 23a and tongue 24a at wrist joint 16. Intermediate idler pulleys 74 and 76 are supported between ear 23b and tongue 24a. Cables C1, C2, C3 and C4 engage driven capstans 18a/18b as well as intermediate idler pulleys 70, 72, 74 and 76 as described later in greater detail.

[0052] Work members 20a and 20b may be removably fixed to respective driven capstans 18a and 18b. Although work members 20a and 20b are depicted in the figures as being grippers, work members 20a and 20b can be replaced with other types of work members such as scissors, cutters, graspers, forceps or needle holders for stitching sutures. Typically, the work members are fixed to driven capstans 18a and 18b by a screw, clip or other suitable fastener. However, the work members may also be permanently affixed to the driven capstans by soldering or welding or the like or may be formed in one piece with the driven capstans.

[0053] Work members 20a and 20b together comprise one form of surgical end effector. Other surgical end effectors may be used in the surgical instrument of the present invention. End effectors simply may comprise standard surgical or endoscopic instruments with their handles removed including, for example, retractors, electrocautery instruments, microforceps, microneedle holders, dissecting scissors, blades, irrigators, and sutures. The end effectors will typically comprise one or two work members.

[0054] Proximal portion 28a of instrument 12 includes support brackets 98 and 102 which are connected together by a support rod 100 as well as two guide rails 104 and 106. A rotary bearing 91 forming rotary joint 26 is housed within support bracket 98 for supporting tubular support member 24. Sliding bracket 96 is slidably mounted to guide rails 104 and 106 along linear bearings. As shown in FIG. 1, sliding bracket 96 is connected by bracket 36 to positioning mechanism 14. Sliding bracket 96 preferably has about 8 inches of travel for surgical applications.

[0055] Drive motors M1, M2, M3, M4 and M5 are mounted to sliding bracket 96 and drive respective cables C1, C2, C3 and C4 and C5. Sliding bracket 96 supports each of the drive motors. During operation sliding bracket 96 is connected to positioning mechanism 14 by mounting bracket 36. When instrument 12 is mounted on positioning mechanism 14, the

drive motors operate to move distal portion **28b** relative to sliding bracket **96**. Sliding bracket **96** thus forms the support bracket of the surgical instrument. Each drive motor **M1**, **M2**, **M3**, **M4** and **M5** includes a respective encoder **E1**, **E2**, **E3**, **E4** and **E5** for providing computer **11** with the rotational position of their respective drive shafts.

[0056] As shown in FIG. 4, drive motor **M5** has a drive shaft capstan **93** which engages a cable drive loop consisting of Cable **C5**. The cable passes around rear tensioning pulley **83**. The cable passes around idler pulleys **84** and **85** and around drive capstan **90** which forms the proximal end of tubular support member **24**. Thus rotation of actuation of motor **M5** can be used to rotate tubular support member **24** and the end effector it supports.

[0057] Referring to FIG. 6, the cable drive system of instrument **12** is now described in greater detail. Work members **20a** and **20b**, wrist member **22** and the translation of instrument **12** along longitudinal axis C-C are driven by cables **C1**, **C2**, **C3** and **C4** which are arranged in an N+1 actuation scheme. The N+1 actuation scheme allows the actuation of a three degree-of-freedom wrist using four cables. Four cables is the theoretical minimum possible number of tension elements required to drive three degrees-of-freedom and thus allows the instrument to be of minimum size and weight. Alternative actuation schemes using more cables may be desirable in situations where the forces required for actuation of different motions differ greatly in magnitude. The disadvantage of using more cables is an increase in weight, complexity and minimum size.

[0058] In FIG. 6, the rotational motion of joint **26** about axis C-C is omitted in order to more easily show cables **C1-C4**. Such rotation results only in twisting of the cables **C1-C4** between motors **M1-M4** and pulleys **70**, **72**, **74** and **76**. The cables are however arranged in tubular support member **24** such that this twisting does not significantly change the length of the cable path. Care should however be taken to prevent over-rotation of the instrument which would cause the cables to twist into contact with each other and create friction between the cables.

[0059] As shown in FIG. 6, cables **C1** and **C2** form two sides of a continuous cable loop **44**. Cable **C1** of loop **44** engages a proximal idler pulley **80**, the drive shaft of motor **M1**, intermediate idler pulley **70** and driven capstan **18a**. Cable loop **44** returns from driven capstan **18a** as cable **C2** and engages intermediate idler pulley **76**, the drive shaft of motor **M2** and proximal idler pulley **80**.

[0060] As shown in FIG. 6, cables **C3** and **C4** form two sides of a continuous loop of cable **46**. Cable **C3** of cable loop **46** engages proximal idler pulley **78**, the drive shaft of motor **M3**, intermediate idler pulley **72** and driven capstan **18b**. Cable loop **46** returns from driven capstan **18b** as cable **C4** and engages intermediate idler pulley **74**, the drive shaft of motor **M4** and proximal idler pulley **78**.

[0061] As shown in FIG. 6, proximal idler pulleys **78** and **80** are tensioned by cables **C7** and **C6** which are fixed to the center of proximal idler pulleys **78** and **80**. Cables **C7** and **C6** form two sides of a single cable **45** which engages proximal idler pulley **82** which is rotatably mounted to support bracket **102** by shaft **82a**. Shaft **82a** is preferably movably mounted to support bracket **102** by a mechanism such as a lead screw. The lead screw may then be adjusted to appropriately tension cables **C7** and **C6**. The tension is also applied via idler pulleys **78** and **80** to cables **C1**, **C2**, **C3** and **C4**. A similar lead screw tensioning scheme can be used to tension cable **C5** by longi-

tudinal movement of idler pulley **83**. It may be required for idler pulleys **82** and **83** to be mounted on separately adjustable shafts for these purpose instead of single shaft **82a** illustrated in FIG. 3.

[0062] Driven capstans **18a** and **18b** may have different diameters in order to allow cables **C1** through **C4** to suitably engage their respective intermediate idler pulleys. Cables **C1** and **C2** engage the outer intermediate idler pulleys **70** and **76** while cables **C3** and **C4** engage the inner intermediate idler pulleys **72** and **74**. Proximal idler pulleys **78** and **80** are sized such that pulley **80** is larger than pulley **78** to keep the cables straight.

[0063] Drive motors **M1**, **M2**, **M3** and **M4** control rotation of wrist member **22** about axis B-B, translation of instrument **12** longitudinally along axis C-C and rotation of work members **22a** and **22b** independent of each other about axis A-A by driving cables **C1**, **C2**, **C3** and **C4**. Drive motors **M1** and **M2** drive cables **C1/C2** in unison in opposition to cables **C3/C4** driven by drive motors **M3** and **M4** in order to rotate wrist member **22** about axis B-B. Drive motor **M1** drives cable **C1** in opposition to cable **C2** driven by drive motor **M2** to rotate capstan **18a** and attached work member **20a** about axis A-A. In addition, drive motor **M3** drives cable **C3** in opposition to cable **C4** driven by drive motor **M4** to rotate capstan **18b** and attached work member **20b** about axis A-A. All four drive motors **M1**, **M2**, **M3** and **M4** drive cables **C1**, **C2**, **C3** and **C4** simultaneously to translate instrument **12** along longitudinal axis C-C.

[0064] Locating drive motors **M1**, **M2**, **M3**, **M4** and **M5** on sliding bracket **96** makes the distal portion **28b** of instrument **12** have a small moving mass since the motors themselves remain stationary during actuation of the instrument. Although the motors are moved by positioning mechanism **14**, the weight and inertia, of the motors do not affect force reflection. This is because, as stated above, in the preferred embodiment, only the instrument is used to reflect forces to the master. In addition, employing cables instead of gears to control instrument **12** minimizes the amount of friction and backlash within instrument **12**. The combination of small moving masses and low friction enables instrument **12** to provide force reflection to master device **150** with high sensitivity.

[0065] Certain possible changes to the configuration of pulleys, cables and motors described above will be apparent to those of skill in the art. Although cables **C1/C2**, **C3/C4**, **C5** and **C7/C6** have been depicted to be sides of the same cables, cables **C1-C7** alternatively can each be individual cables which are fixed to driven capstans **18a** and **18b**, and proximal idler pulleys **78**, **80** and **82**. Moreover, although drive motors **M1**, **M2**, **M3** and **M4** have been depicted to drive cables **C1**, **C2**, **C3** and **C4** respectively, alternatively, some drive motors can be relocated from cables **C1-C4** onto cables **C7** and **C6** for driving cables **C7** and **C6**. The choice of the particular drive scheme employed in a particular embodiment will depend on the constraints of the forces required to be exerted by the instrument and the need to reduce the inertia and friction of the parts of the instrument that move during its actuation.

[0066] The surgical instrument of the present invention has been illustrated as using drive motors **M1**, **M2**, **M3**, **M4** and **M5**. This drive motors may be standard servo motors having position encoders as shown in FIG. 3. However, other actuators may be used, such as hydraulic actuators and piezoelectric motors. To be used as an actuator in the present surgical

instrument a drive mechanism should be able to provide variable and controllable force and position control.

[0067] Cables C1, C2, C3, C4, C7, C8 and C9 are driven by being wrapped about the drive shaft of their respective drive motors M1, M2, M3, M4, M5, M6 and M7. This cable drive method and an alternative cable drive method are illustrated in more detail in FIGS. 7a and 7b. For example, in FIG. 7a, cable C4 of cable loop 46 is wrapped around the drive shaft of motor M4. Cable C4 is preferably wrapped two times around the drive shaft to provide enough friction between the cable C4 and the drive shaft to prevent slippage. In order to further prevent slippage the cable may be fixed to the drive shaft at one point by soldering, welding or mechanical fixing means. However, in such an embodiment the range of motion of the cable is limited by the length of cable wrapped around the drive shaft or capstan thus several turns of cable are usually required.

[0068] FIG. 7b depicts another preferred method for driving cables. For example, motor M4 includes a drive wheel 43a and an idler wheel 43b for frictionally driving an elongate member 47 therebetween. Cable C4 consists of two halves, 46a and 46b which are fixed to opposite ends of member 47.

[0069] FIG. 8 depicts the distal end and wrist member 116 of another preferred instrument 117. Instrument 117 differs from instrument 12 in that instrument 117 includes eight intermediate idler pulleys instead of four. Instrument 117 includes intermediate idler pulleys 76, 74, 72 and 70 at wrist joint 16 but also includes intermediate idler pulleys 76a, 74a, 72a and 70a which are positioned adjacent to idler pulleys 76, 74, 72 and 70 on tongue 24a along shaft 118. Cables C1, C2, C3 and C4 do not make a complete wrap around each intermediate idler pulley but instead contacts a variable amount of the surface of each pulley varying in a range between 0.degree. and 180.degree. over the range of motion of the wrist about axis 16. This prevents the cables from crossing each other and rubbing together which prevents friction and noise.

[0070] Although the present invention has been described for performing laparoscopic surgery, it may also be used for other forms of endoscopic surgery as well as open surgery. The present manipulator could also be employed for any suitable remote controlled application requiring a dexterous manipulator with high quality force feedback. Moreover, while this invention has been particularly shown and described with references to preferred embodiments thereof, it will be understood by those skilled in the art that various changes in form and details may be made therein without departing from the spirit and scope of the invention as defined by the appended claims.

1. (canceled)
2. An articulated surgical instrument for minimally invasive surgery comprising:
 - a sliding bracket coupled to at least one guide rail, the sliding bracket configured to slide along the longitudinal axis of the at least one guide rail;
 - an elongate support member having a proximal end coupled to the sliding bracket and to the at least one guide rail, the support member being movable along its longitudinal axis by sliding the sliding bracket relative to the at least one guide rail;

- a wrist member coupled to the distal end of the elongate support member, the wrist member rotatable relative to the elongate support member about a first axis;
 - a surgical end effector coupled to the wrist member, the surgical end effector comprising a first work member rotatable relative to the wrist member about a second axis; and
 - actuators disposed at the sliding bracket, the actuators coupled to the wrist member by cables to rotate the wrist member about the first axis, the actuators further coupled to the first work member by cables to rotate the first work member about the second axis.
3. The instrument of claim 2, the first axis being perpendicular to the second axis:
 4. The instrument of claim 3, further comprising an auxiliary actuator coupled to the proximal end of the elongate support member by an auxiliary cable, the auxiliary actuator disposed on the sliding bracket, the auxiliary actuator rotating the support member about its longitudinal axis relative to the sliding bracket by pulling the auxiliary cable.
 5. The instrument of claim 2, further comprising a mounting bracket coupled to the sliding bracket, the mounting bracket adapted to releasably connect the articulated surgical instrument to a positioning mechanism.
 6. The instrument of claim 5, the positioning mechanism comprising a remote centering mechanism for pivoting said instrument about a minimally invasive surgical entry point.
 7. The instrument of claim 2, the actuators disposed at the sliding bracket being configurable to translate the support member along its longitudinal axis.
 8. A surgical instrument comprising:
 - a sliding bracket a sliding bracket coupled to at least one guide rail, the sliding bracket configured to slide along the longitudinal axis of the at least one guide rail;
 - an elongate support member having a proximal end coupled to the sliding bracket and to the at least one guide rail, the support member being movable along its longitudinal axis by sliding the sliding bracket relative to the at least one guide rail;
 - a wrist member coupled to the distal end of the elongate support member, the wrist member rotatable relative to the elongate support member about a first axis;
 - a surgical end effector coupled to the wrist member, the surgical end effector comprising a first work member rotatable relative to the wrist member about a second axis;
 - pulley means disposed at the wrist member for moving the wrist member and the surgical end effector; and
 - actuation means disposed at the sliding bracket for selectively actuating the pulley means.
 9. The instrument of claim 8, the actuation means further comprising means for driving the elongate support member to cause the support member to move along its longitudinal axis.
 10. A method of actuating a surgical instrument, the surgical instrument comprising a sliding bracket coupled to at least one guide rail, the instrument further comprising an elongate support member having a proximal end coupled to the sliding bracket and to the at least one guide rail, a wrist member coupled to the distal end of the elongate support member, and a surgical end effector coupled to the wrist member, the surgical end effector comprising a first work member, the method comprising:

moving the support member along its longitudinal axis by sliding the sliding bracket relative to the at least one guide rail;
selectively actuating a plurality of actuators disposed at the sliding bracket;
rotating the wrist member relative to the elongate support member about a first axis in response to said selective actuation; and

rotating the first work member relative to the wrist member about a second axis in response to said selective actuation.

11. The method of claim **10**, further comprising translating the support member along its longitudinal axis in response to said selective actuation.

* * * * *