

(12) STANDARD PATENT
(19) AUSTRALIAN PATENT OFFICE

(11) Application No. **AU 2005200490 B9**

(54) Title
Bed construction with reduced sagging

(51) International Patent Classification(s)
A47C 27/06 (2006.01) **A47C 23/00** (2006.01)
A47C 19/00 (2006.01) **A47C 27/04** (2006.01)

(21) Application No: **2005200490** (22) Date of Filing: **2005.02.04**

(43) Publication Date: **2005.02.24**

(43) Publication Journal Date: **2005.02.24**

(44) Accepted Journal Date: **2008.07.03**

(48) Corrigenda Journal Date: **2008.08.07**

(62) Divisional of:
2001226384

(71) Applicant(s)
Dreamwell, Ltd.

(72) Inventor(s)
Gladney, Rick F.;Kinde, Douglass D.;Ling, Kurtis

(74) Agent / Attorney
Shelston IP, 60 Margaret Street, Sydney, NSW, 2000

Abstract

A bed construction having a one-sided mattress assembly supported on a rigid foundation. The one-sided mattress assembly includes a core of pocketed coil springs
5 having a layer of resiliently compressible material covering the upper surface thereof
and having a bottom surface constructed of a substantially rigid material without a
compressible layer. The core of coil springs is attached to the bottom surface around its
periphery. The foundation has a rigid inner construction and a noncompressible top
10 layer. The bed construction reduces the amount of compressible padding in the mattress
by one-half and consequently the mattress is capable of exhibiting a substantial
reduction in the amount of permanent deflection in use.

FIG 2

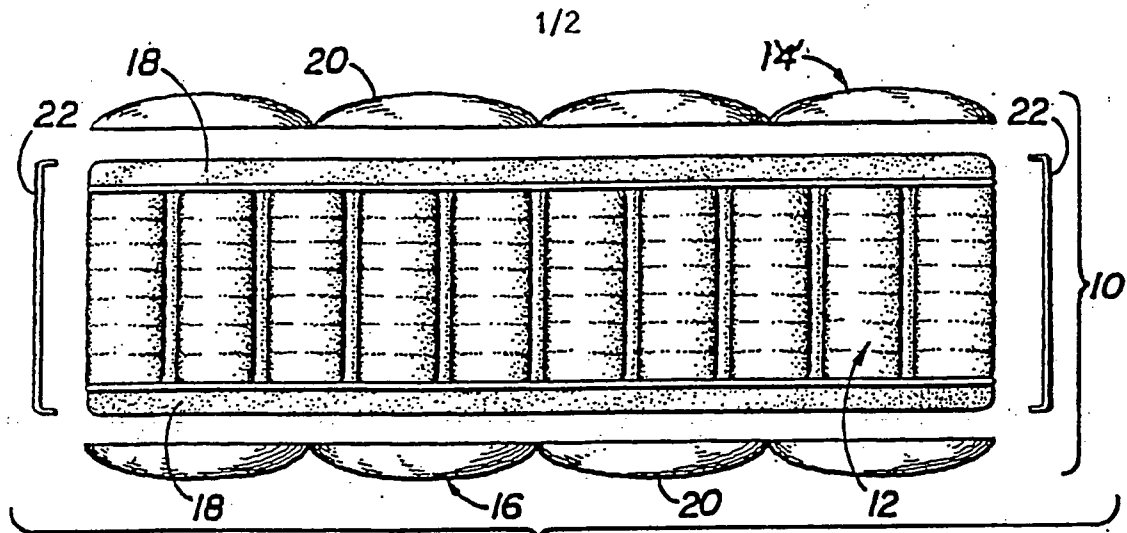

(PRIOR ART)

FIG 1

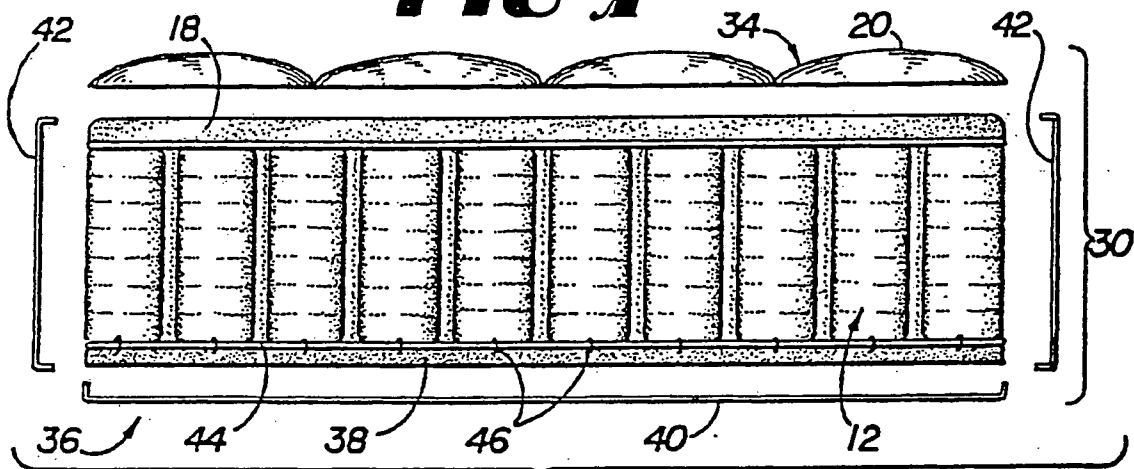

FIG 2

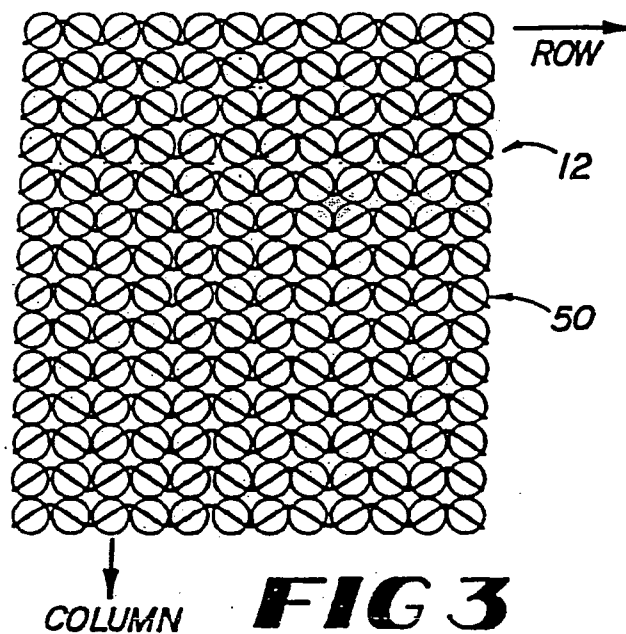

FIG 3

AUSTRALIA

PATENTS ACT 1990

COMPLETE SPECIFICATION

FOR A STANDARD PATENT

ORIGINAL

Name of Applicant: Dreamwell, Ltd

Actual Inventors: Rick F. Gladney and Kurtis Ling and Douglass D. Kinde

Address for Service is:

SHELSTON IP
60 Margaret Street
SYDNEY NSW 2000

Telephone No: (02) 9777 1111
Facsimile No. (02) 9241 4666

CCN: 3710000352

Attorney Code: SW

Invention Title: BED CONSTRUCTION WITH REDUCED SAGGING

Details of Original Application No. 2001226384 dated 10 January 2001

The following statement is a full description of this invention, including the best method of performing it known to us:-

File: 35972AUP01

BED CONSTRUCTION WITH REDUCED SAGGING

BACKGROUND OF THE INVENTION

The present invention relates generally to a bed construction, and more particularly
5 to a bed construction having a one-sided mattress assembly supported on a rigid
foundation that offers significant reduction in the amount of permanent deflection or
sagging of sleeping surface of the mattress.

Any discussion of the prior art throughout the specification should in no way be
considered as an admission that such prior art is widely known or forms part of common
10 general knowledge in the field.

A conventional inner spring mattress as known in the bedding industry generally
comprises a resilient construction consisting of two sleep surfaces (a top layer and a
bottom layer) enclosing an assembly of wire springs. The wire springs are typically
covered with padding layers on the top and bottom surfaces, and the whole assembly is
15 encased within a ticking, often quilted, that is sewn closed around its periphery to a
border or boxing. For many years, one form of spring assembly construction has been
known as Marshall construction. In Marshall construction, individual wire coils are each
encapsulated in fabric pockets and attached together in strings which are arranged to
form a closely packed array of coils in the general size of the mattress. Examples of such
20 construction are disclosed in U.S. Patent No. 685,160, U.S. Patent No. 4,234,983, U.S.
Patent No. 4,234,984, U.S. Patent No. 4,439,977, U.S. Patent No. 4,451,946, U.S. Patent
No. 4,523,344, U.S. Patent No. 4,578,834, U.S. Patent No. 5,016,305 and U.S. Patent
No. 5,621,935, the disclosures of which are incorporated herein by reference in their
entireties.

25 Conventionally, inner spring mattresses, with either pocketed coils or open coils,
have had identical top and bottom layers. During normal life of such conventional
mattresses some degree of permanent deflection, or sag, can develop in the mattress
surfaces due to compaction of the component padding materials in the top and bottom
layers. This permanent deflection can interfere with the mattresses' intended function of
30 providing a supportive and resilient sleep surface. Inner spring mattress manufacturers
recommend periodically rotating and turning over the mattress thereby utilizing the top
and bottom sleep surfaces in order to counteract, minimize, and/or delay the
aforementioned permanent deflection or sag. Under continued use, this compaction or

sag becomes more permanent. The degree of permanent deflection is directly related to the type and amount of padding installed both over and under the wire spring core assembly. To remedy this shortcoming, manufacturers utilize materials that produce less permanent compaction. These materials are generally more dense but can be less comfortable and more expensive.

Conventional foundations, such as box springs, often contributed to the problem of sagging by providing a compressible top layer. Any additional compaction of the top layer of the foundation contributes to the overall sagging of the sleeping surface of the mattress.

It is an object of the present invention to overcome or ameliorate at least one of the disadvantages of the prior art, or to provide a useful alternative.

In particular, it is desirable to provide a bed construction having an inner spring mattress assembly which exhibits a reduced amount of permanent deflection due to compaction of padding materials while at the same time exhibiting substantial comfort in use. It is further desirable to provide a mattress assembly that can be constructed by conventional known manufacturing techniques. Still further, it is desirable to provide a mattress assembly that is cost-effective to produce.

SUMMARY OF THE INVENTION

According to a first aspect of the invention, there is provided an inner spring mattress assembly adapted to be used with only one of its sides as a sleeping surface for a user, comprising:

- a central core comprising a wire spring assembly;
 - an upper padding layer extending over a top surface of the core; and
 - a lower relatively rigid layer underlying the core;
- wherein the lower layer is a high density foam, having a firmness of greater than 30 ILD, that is resistant to compaction by the central core of springs, thereby reducing permanent deflection of the sleeping surface by the user.

According to a second aspect of the invention, there is provided a bed construction comprising:

- a full-length inner spring mattress assembly adapted to be used with only one of its sides as a sleeping surface for a user comprising:
 - a full-length central core comprising a wire spring assembly;

a full-length quilted upper padding layer extending over a top surface of the core and defining the sleeping surface;

a lower relatively rigid layer underlying the core,

wherein the lower layer is a high density foam with a firmness of greater than 30
5 ILD that supports the central core and is resistant to compaction by the central core of springs, thereby reducing permanent deflection of the sleeping surface by the user; and
a rigid foundation facing said lower layer and supporting the mattress.

According to a third aspect of the invention, there is provided a one-sided inner spring mattress assembly comprising:

10 a central core comprising a wire spring assembly having a lower border wire;
an upper padding layer extending over a top surface of the core and defining a sleeping surface; and

a lower rigid layer secured to the lower border wire and being disposed underlying and against the central core,

15 wherein the lower layer contacts and supports the central core to reduce permanent deflection from within the sleeping surface arising from compaction of a lower compressible layer by the wire spring assembly of the central core.

According to a fourth aspect of the invention, there is provided a one-sided inner spring mattress assembly comprising:

20 a central core comprising a wire spring assembly;
an upper padding layer extending over a top surface of the core and defining a sleeping surface; and

a lower rigid layer underlying the central core and disposed against the central core without a compressible layer therebetween,

25 wherein the lower layer is a solid plastic material that is resistant to compaction by the central core of springs and wherein the core is surrounded by a lower border wire and is secured to said lower layer by attaching said border wire to said lower layer.

According to a fifth aspect of the invention, there is provided a bed construction comprising:

30 a one-sided inner spring mattress assembly comprising:

a central core comprising a wire spring assembly and a wire placed around a lower border of the wire spring assembly;

an upper padding layer extending over a top surface of the core;

a lower relatively rigid layer underlying the core;
wherein the lower layer is a high density foam that is resistant to compaction by the central core of springs and the wire around the lower border of the wire spring assembly is secured to the lower layer, and

5 a rigid foundation for supporting the mattress.

According to a sixth aspect of the invention, there is provided a bed construction comprising:

a one-sided inner spring mattress assembly comprising:

a central core comprising a wire spring assembly;

10 an upper padding layer extending over a top surface of the core;

a lower relatively rigid layer underlying the core;

wherein the lower layer is a solid plastic material that is resistant to compaction by the central core of springs and wherein the core is surrounded by a lower border wire and is secured to said lower layer by attaching said border wire to said lower layer, and

15 a rigid foundation for supporting the mattress.

According to a seventh aspect of the invention, there is provided a method of manufacturing a one-sided inner spring mattress assembly, comprising:

providing a central core having a top surface and a bottom surface and having a wire spring assembly having a plurality of wire spring elements and a lower border wire;

20 attaching an upper padding layer over the top surface of the central core to define a sleeping surface;

positioning the lower layer against the central core to support the wire spring assembly and attaching a lower layer of a substantially rigid material to the lower border wire of the central core, and whereby the lower layer contacts the central core to reduce permanent deflection from within the sleeping surface and arising from movement of

25 one or more of the wire spring elements settling into a lower layer of padding; and

upholstering the lower layer by attaching a layer of material directly over an exterior surface of the lower layer.

Thus, the present invention at least in its preferred embodiment improves over the
30 prior art by providing a bed construction with a one-sided mattress assembly supported on a rigid foundation. The one-sided mattress assembly includes a core of wire springs including, but not limited to, pocketed or open coil springs. The spring core of the mattress is covered by a layer of resiliently compressible material covering the upper

sleeping surface thereof. The spring core of the mattress is supported on a bottom layer constructed of a substantially rigid material that is not generally compressible. The core of coil springs is attached to the bottom layer around its periphery. The rigid bottom layer of the mattress assures firm support for the coil springs and thereby reduces
5 sagging that may result from the springs being poorly supported by the compressible padding under the springs of a conventional two-sided mattress.

In connection with the present invention, the padding for the top layer is selected to resist permanent compaction or deflection. Moreover, padding is only needed on the top layer of the mattress thereby reducing by one-half the amount of padding required.
10 Consequently, the mattress construction of the present invention with a padded top layer and a rigid bottom layer necessarily reduces the amount of material that is subject to permanent compaction and therefore reduces the amount of permanent deflection of the mattress overall. Maintenance of the mattress of the present invention by rotating or turning the mattress over is also avoided.

15 In order to further reduce sagging of the sleeping surface of the mattress, a rigid foundation is provided to give further support to the rigid bottom layer of the one-sided mattress and therefore the spring core.

Unless the context clearly requires otherwise, throughout the description and the claims, the words 'comprise', 'comprising', and the like are to be construed in an
20 inclusive sense as opposed to an exclusive or exhaustive sense; that is to say, in the sense of "including, but not limited to".

BRIEF DESCRIPTION OF THE DRAWINGS

The foregoing and other novel features and advantages of the invention will be
25 better understood upon a reading of the following detailed description taken in conjunction with the accompanying drawings wherein.

FIG. 1 is an exploded cross-section view of a conventional two-sided inner spring mattress;

FIG. 2 is an exploded cross-sectional view of a one-sided inner spring mattress
30 constructed according to the principles of the invention;

FIG. 3 is a schematic plan view of a complete assembly of Marshall coils for use in the mattress construction according to the present invention illustrated in FIG. 2;

FIG. 4 is a partial perspective view, partly broken away, of the Marshall coil assembly illustrated in FIG. 3; and

FIG. 5 is a partially exploded elevation view of a foundation used in connection with the present invention.

5

DETAILED DESCRIPTION OF THE INVENTION

Referring now to the drawings, and initially to FIG. 1, a conventional two-sided mattress is illustrated in exploded cross-section and designated generally by the reference numeral 10. The conventional mattress 10 includes as a principal component a wire spring assembly 12 of Marshall spring coils, as will be described in detail hereinafter and which comprises the central core of the mattress 10. The mattress 10 could also incorporate an assembly of open coil springs or other wire inner springs. The mattress 10 has an upper sleep surface 14 and a lower sleep surface 16, and therefore, is of a conventional type intended to be turned over periodically to help minimize compaction of its padding material and the resulting sagging of the mattress 10. Padding material 18, which is identical on both sides 14 and 16 includes a layer of closed-cell foam such as polyurethane. Covering the material 18, on both sides of the mattress, is a ticking layer 20 which may be quilted and which may include additional foam in a manner well-known in the art. The ticking layers 20 are fastened such as by sewing to a border 22 which extends around the entire periphery of the core 12 of coil springs.

Turning now to FIG. 2, a mattress 30 constructed according to the invention is shown in exploded cross-section. The mattress 30, like the conventional mattress 10 illustrated in FIG. 1, has a central core 12 of the Marshall coils. The mattress 30, however, may have a central core 12 comprising open coil springs or other wire springs. An upper sleep surface 34 is formed over the central core 12 by a layer of foam padding 18 and a layer of ticking 20. In accordance with the invention, however, the mattress 30 has an underside 36, positioned under the central core 12 and which comprises a substantially rigid layer 38 of material covered by a thin layer 40 of a non-woven sheeting. A border 42 connects the ticking 20 and sheeting layer 40 and extends around the periphery of the coil spring assembly 12. A lower border wire 44 is secured to the coil spring assembly 12 around its periphery as well as to the layer 38 such as by hog rings 46.

FIGS. 3 and 4 illustrate one form of mattress core 12 of the aforementioned Marshall coil construction. In this construction, closely positioned coil springs are aligned in a string assembly 50 (FIG. 4) wherein individual springs 52 are each encapsulated within a pocket of 54 of fabric material 56 which may be sewn or
5 ultrasonically welded to create the pockets 54 and to create a unitary Marshall coil type assembly 12. An example of such construction is more fully disclosed in U.S. Patent No. 5,621,935 which is commonly assigned herewith and the disclosure of which is incorporated herein by reference in its entirety. A person of ordinary skill in the art will appreciate that opened coil springs or other wire springs may be used for the mattress
10 core 12 as well as Marshall coil springs.

As previously described, the sleeping surface 34 comprises a layer of foam padding 18 and a layer of ticking 20. The ticking 20 is of conventional construction. In accordance with the present invention, however, the foam padding 18 is specifically selected to provide comfort yet minimize compaction. Particularly, the foam padding 18
15 is a high density polyurethane foam having a density from about 1.0 lbs./cu. ft to 2.5 lbs./cu. ft. The foam layer 38 also has a firmness in a range of between 10 and 55 ILD, where "ILD" refers to the standard Indented Load Deflection test. Within the ranges specified, the foam padding 18 for the sleeping surface 34 is selected to provide varying degrees of firmness or softness to accommodate individual preferences.

20 The relatively rigid bottom layer 38 is a high density polyurethane foam having a density of approximately 1.85 lbs./cu. ft. The foam layer 38 also has a firmness above 30 ILD. In practice, an ILD above 55 has proven to be most effective based on considerations of cost and durability. Other rigid materials may be used in place of the foam layer 38. Such materials may include solid plastic, wood, or other nonyielding
25 rigid materials. To the extent such materials for the layer 38 yield to pressure, such materials must have at least a high degree of recoverability once the pressure has been removed so that the materials are not compacted.

Turning to Fig. 5, there is shown a foundation 60 for use in connection with the construction of a bed in accordance with the present invention. The most important
30 aspect of the foundation 60 for the present invention is providing a rigid top surface 62 to support the mattress 30 (Fig. 2). Rigid support of the mattress 30 by the foundation 60 further reduces the amount of sagging of the sleeping surface 34. In order to achieve rigid support of the mattress 30, the foundation 60 is constructed in accordance with the

disclosure of commonly assigned United States Patent No. 5,940,908, and particularly Fig. 6 of that patent.

The foundation 60 has a structural frame 64. The structural frame 64 has a rectangular border including a pair of side rails (only rail 66 is shown in Fig. 5). The side rails may be formed from standard lumber of construction grade in nominal 1x3 size, 5 connected at a head end of the frame 64 by a head end rail 68 and at the foot end of the frame 64 by a foot end rail 70. The end rails 68 and 70 may be formed, for example, from a lower 1x2 end filler slat which butts the side rails in the plane thereof. Cross slats 72, 74, 76, 78, 80, 82, and 84 are positioned on the upper surfaces of the side rails and 10 extend laterally to span the transverse distance between the side rails. Optionally, a longitudinally extending center support rail may be attached to an undersurface of the head and foot rails 68 and 70 and secured to an underside of each of the cross slats 72-84 to provide additional structural integrity and strength for the frame 64.

As further illustrated in FIG. 5, it will be seen that cross slats 80, 82, and 84 are 15 centrally positioned along the length of the frame 10 and have an L-shaped cross-section configuration. However, it should be noted that the L-shaped cross slats may be positioned elsewhere along the length of the frame 64 or be employed in a lesser or a greater number. The L-shaped cross slats 80, 82, and 84 act as reinforcing braces or beams to reduce deflection of the frame 64.

As illustrated in FIG. 5, the non-resilient bedding foundation 60 has a mattress 20 support assembly 86. The mattress support assembly 86 comprises a plurality of wire support members 88 supported on and attached to the cross slats 68, 70, 72, 74, 76, 78, 80, 82, and 84. In this embodiment, a top layer 63 is applied over the assembly 86 and a cover or ticking 90 is provided to form the exterior surface for the entire foundation 60. 25 The top layer 63 is similar in construction and performance to the bottom layer 68 of the mattress 30. Particularly, the top layer 63 is designed to provide a rigid support surface for the mattress 30 with a firmness above 30 ILD and specifically above 55 ILD.

The one-sided inner spring mattress 30 constructed according to the invention 30 offers considerable advantages over prior art conventional two-sided mattresses in terms of reducing the amount of permanent deflection of the sleeping surface due to undesirable compaction of padding materials. Because the mattress 30 essentially has a 50 percent reduction in padding due to the rigid bottom layer 38, the coil assembly 12 does not settle into and compact a lower padding layer as would happen with a two-

sided mattress of conventional construction having identical padding layers on both sides. The addition of a rigid foundation beneath the one-sided mattress 30 also provides additional support for the coil springs of the mattress 30 and thus helps further reduce sagging.

5 The one-sided mattress 30 of the invention also offers the advantage of eliminating maintenance of the mattress by periodically turning it over as is recommended for conventional two-sided mattresses. Accordingly, the one-sided mattress 30 is more convenient for the consumer to use. Further, the Marshall coil construction or open spring construction use conventional materials so that the one-sided
10 mattress 30 may be readily manufactured by techniques that are well known in the industry. The foundation 60 likewise can be constructed using conventional manufacturing techniques.

 While the present invention has been described in connection with certain embodiments thereof, it will be apparent to those skilled in the art that many changes
15 and modifications can be made without departing from the true spirit and scope of the present invention. Accordingly, it is intended by the appended claims to cover all such changes and modifications as come within the scope of the invention.

THE CLAIMS DEFINING THE INVENTION ARE AS FOLLOWS:-

1. An inner spring mattress assembly adapted to be used with only one of its sides as a sleeping surface for a user, comprising:
 - a central core comprising a wire spring assembly;
 - 5 an upper padding layer extending over a top surface of the core; and
 - a lower relatively rigid layer underlying the core;
 - wherein the lower layer is a high density foam, having a firmness of greater than 30 ILD, that is resistant to compaction by the central core of springs, thereby reducing permanent deflection of the sleeping surface by the user.
- 10 2. The mattress assembly of claim 1 wherein the lower layer has a density of approximately 1.85 lbs./cu. ft. and a firmness of approximately 55 ILD.
3. The mattress assembly of claim 1 or claim 2 wherein the central core comprises
15 pocketed springs.
4. The mattress assembly of any one of claims 1 to 3 wherein the core is surrounded by a lower border wire and is secured to said lower layer by attaching said border wire to said lower layer.
- 20 5. A bed construction comprising:
 - a full-length inner spring mattress assembly adapted to be used with only one of its sides as a sleeping surface for a user comprising:
 - a full-length central core comprising a wire spring assembly;
 - 25 a full-length quilted upper padding layer extending over a top surface of the core and defining the sleeping surface;
 - a lower relatively rigid layer underlying the core,
 - wherein the lower layer is a high density foam with a firmness of greater than 30 ILD that supports the central core and is resistant to compaction by the central core of
30 springs, thereby reducing permanent deflection of the sleeping surface by the user; and
 - a rigid foundation facing said lower layer and supporting the mattress.

6. The mattress assembly of claim 5, wherein the lower layer has a density of approximately 1.85 lbs./cu. ft. and a firmness of approximately 55 ILD.
7. The mattress assembly of claim 5 or claim 6, wherein the central core comprises
5 pocketed springs.
8. The mattress assembly of any one of claims 5 to 7 wherein the core is surrounded by a lower border wire and is secured to said lower layer by attaching said border wire to said lower layer.

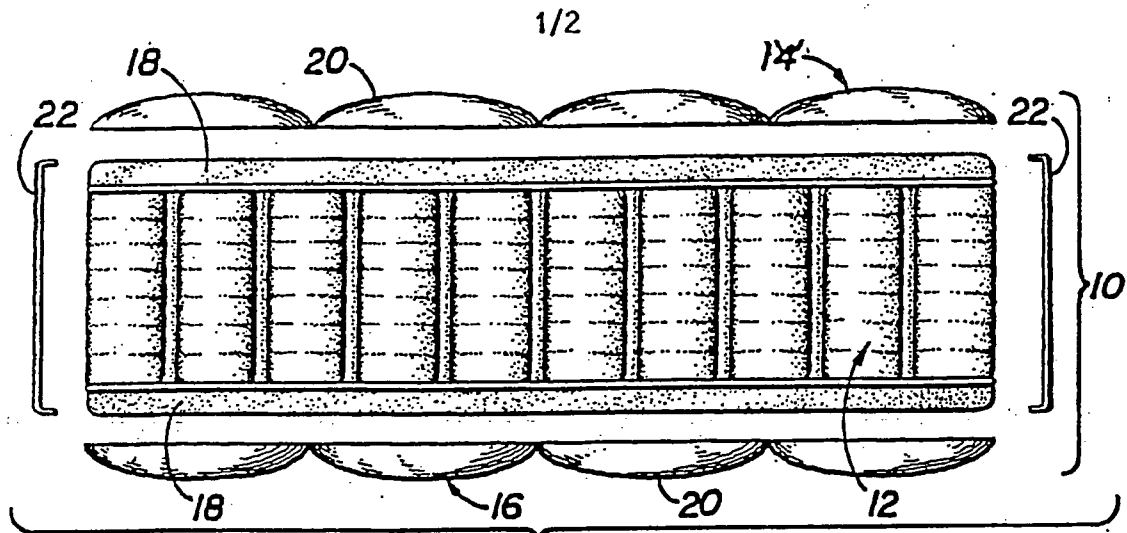

(PRIOR ART)

FIG 1

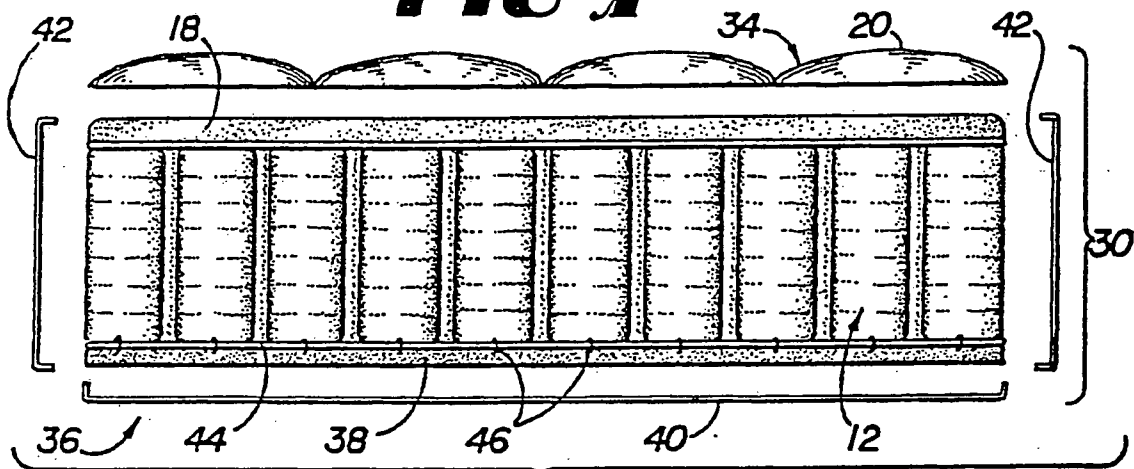

FIG 2

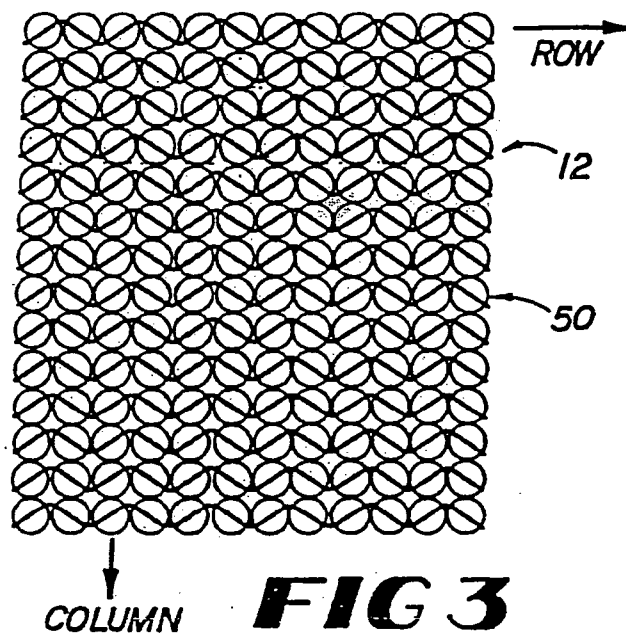

FIG 3

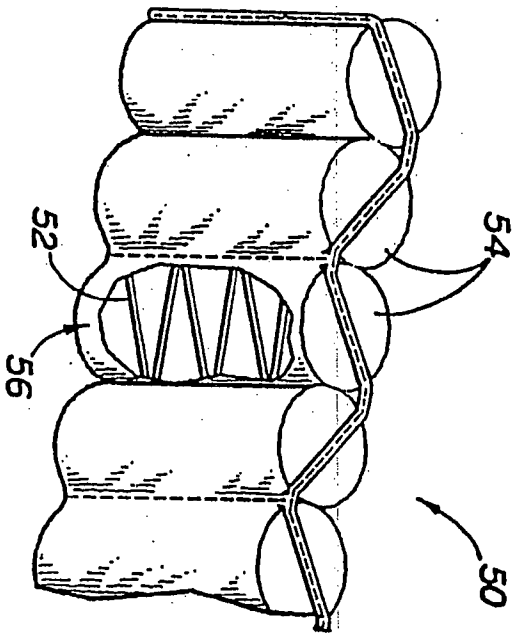

FIG 4

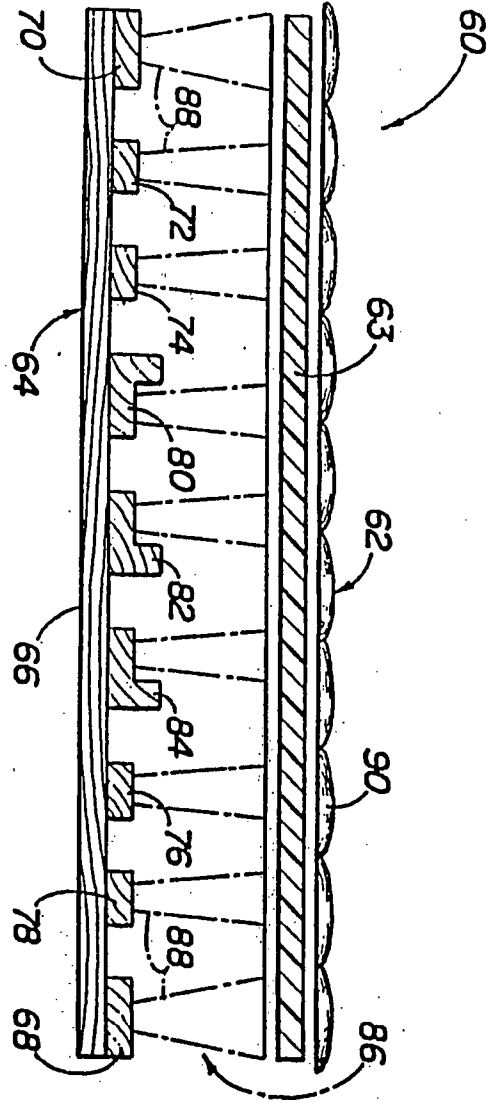

FIG 5