

FIG. 1

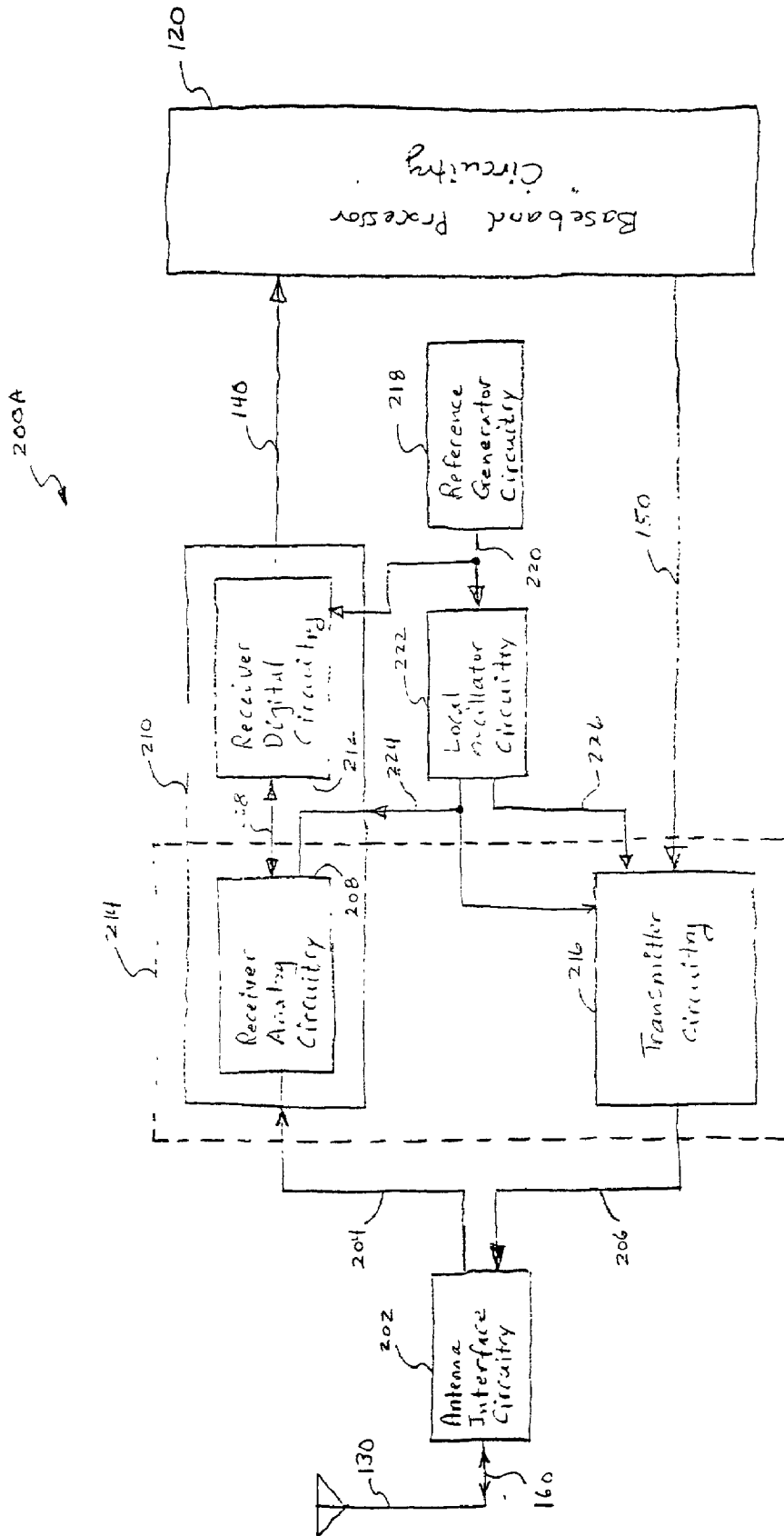

FIG. 2 A

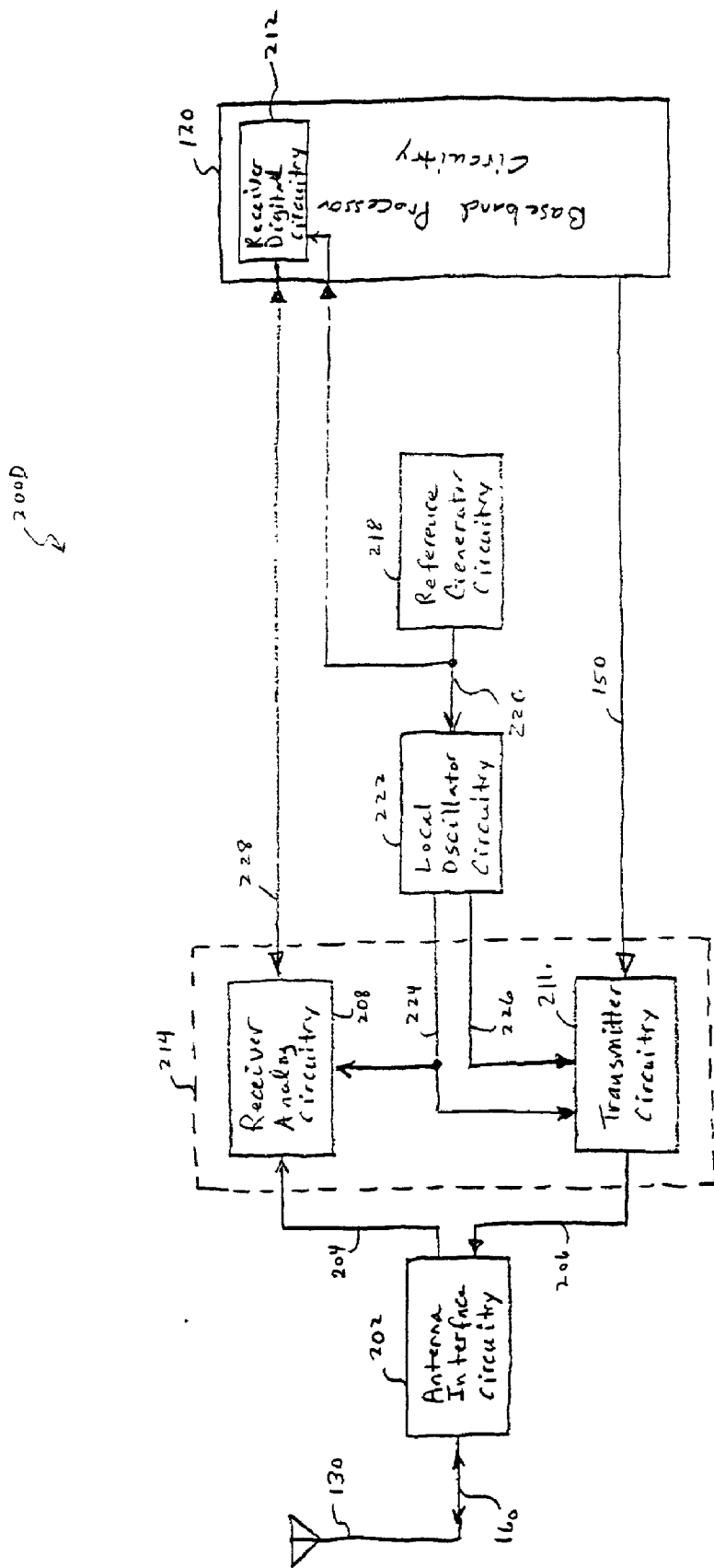

FIG. 2D

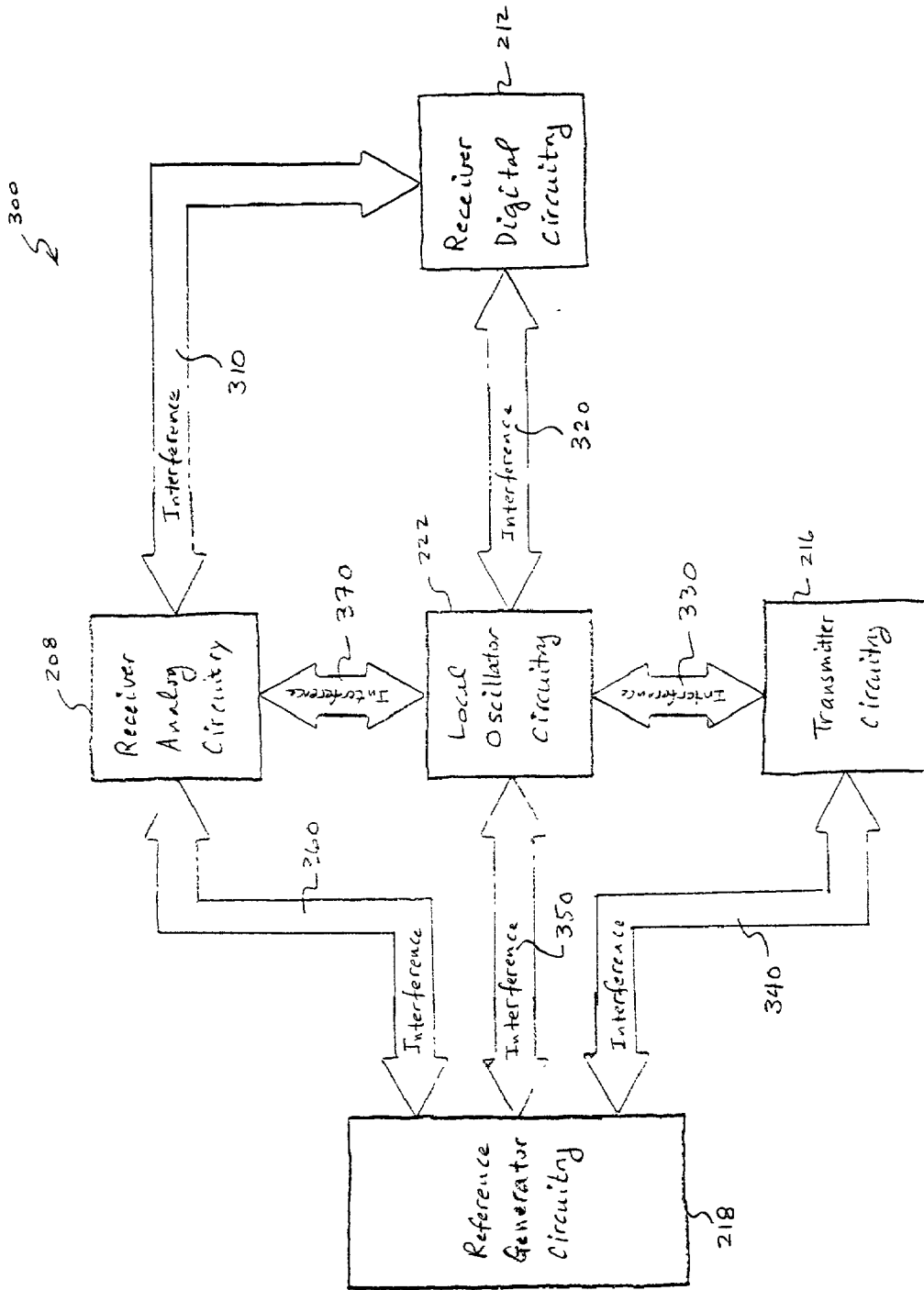

FIG. 3

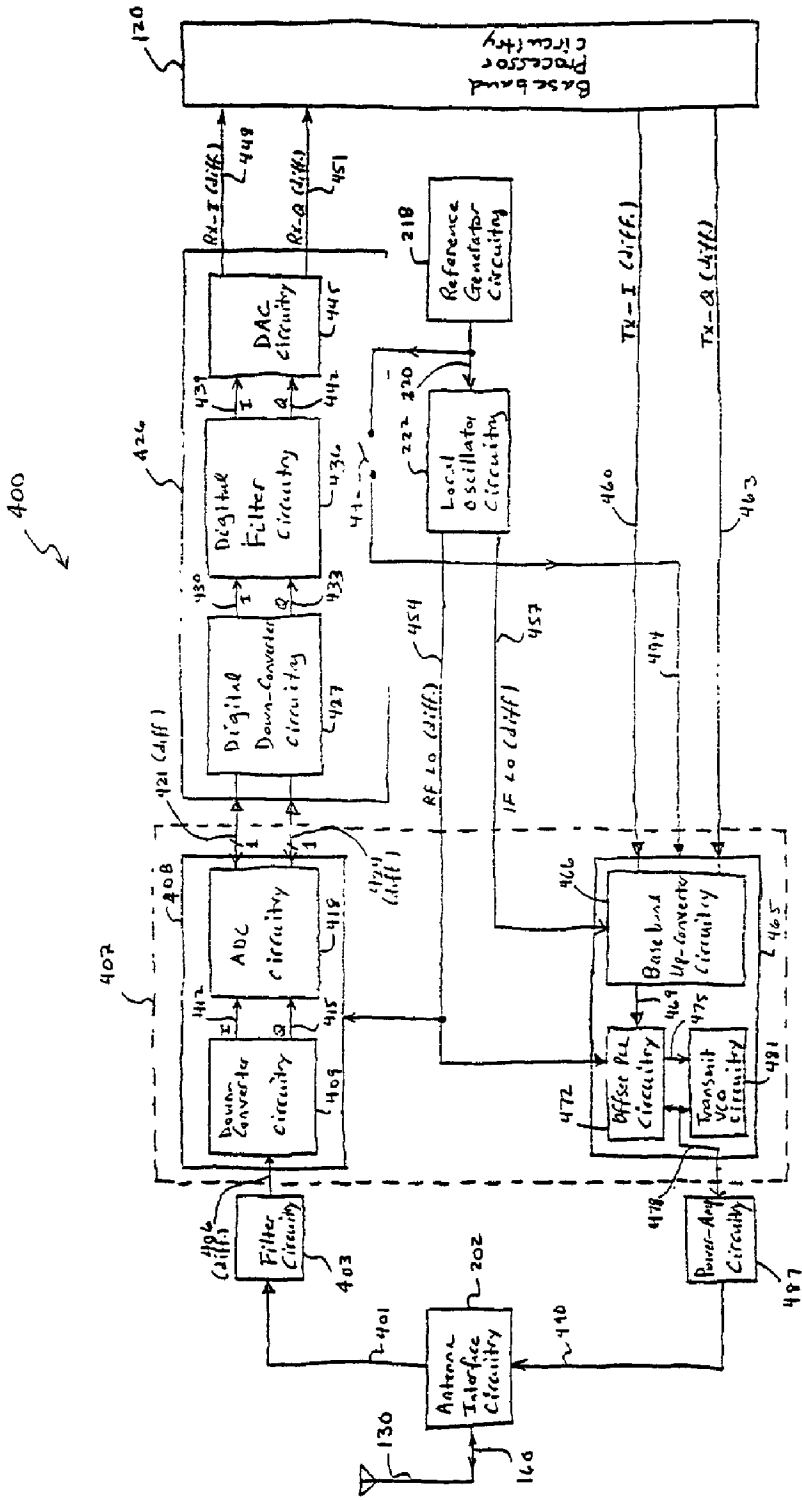

FIG. 4

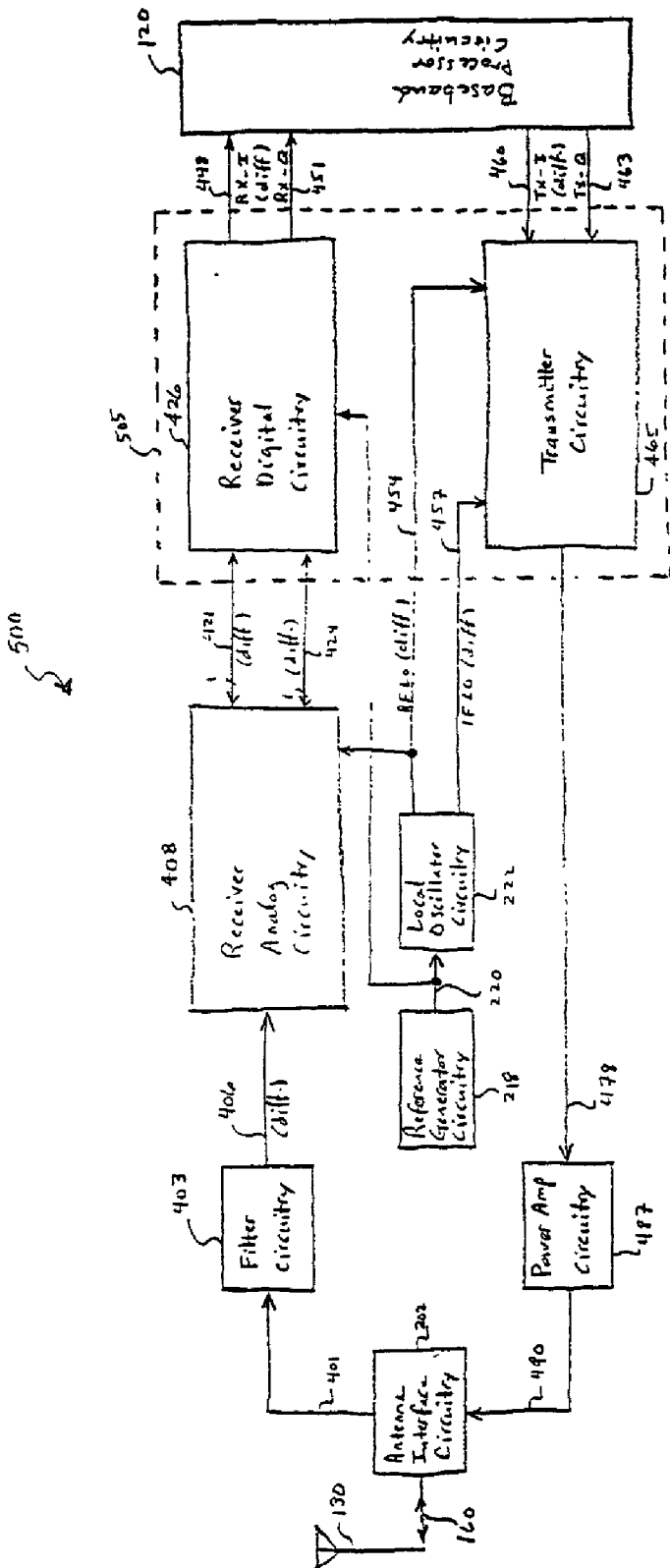

FIG. 5

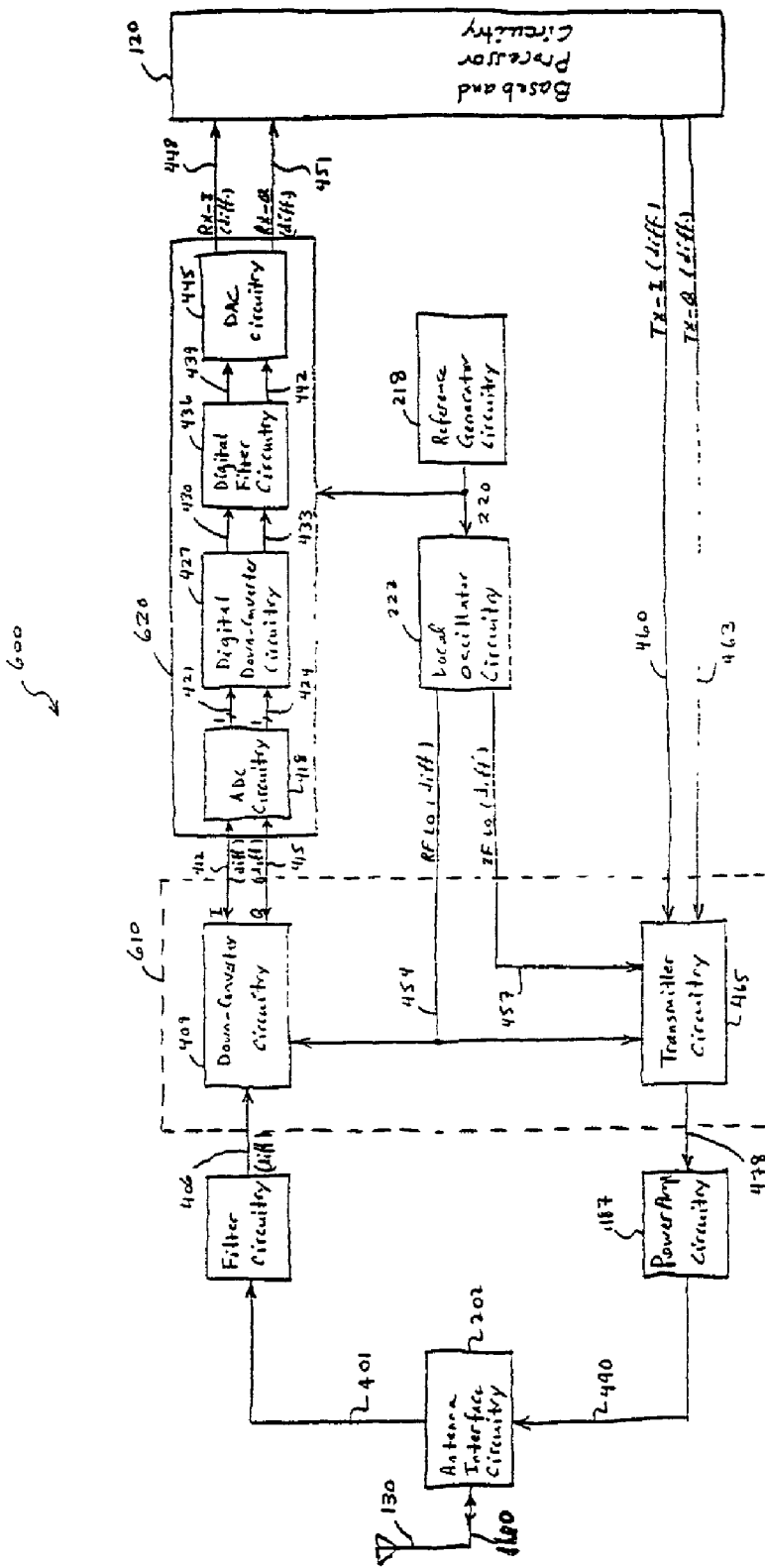

FIG. 6

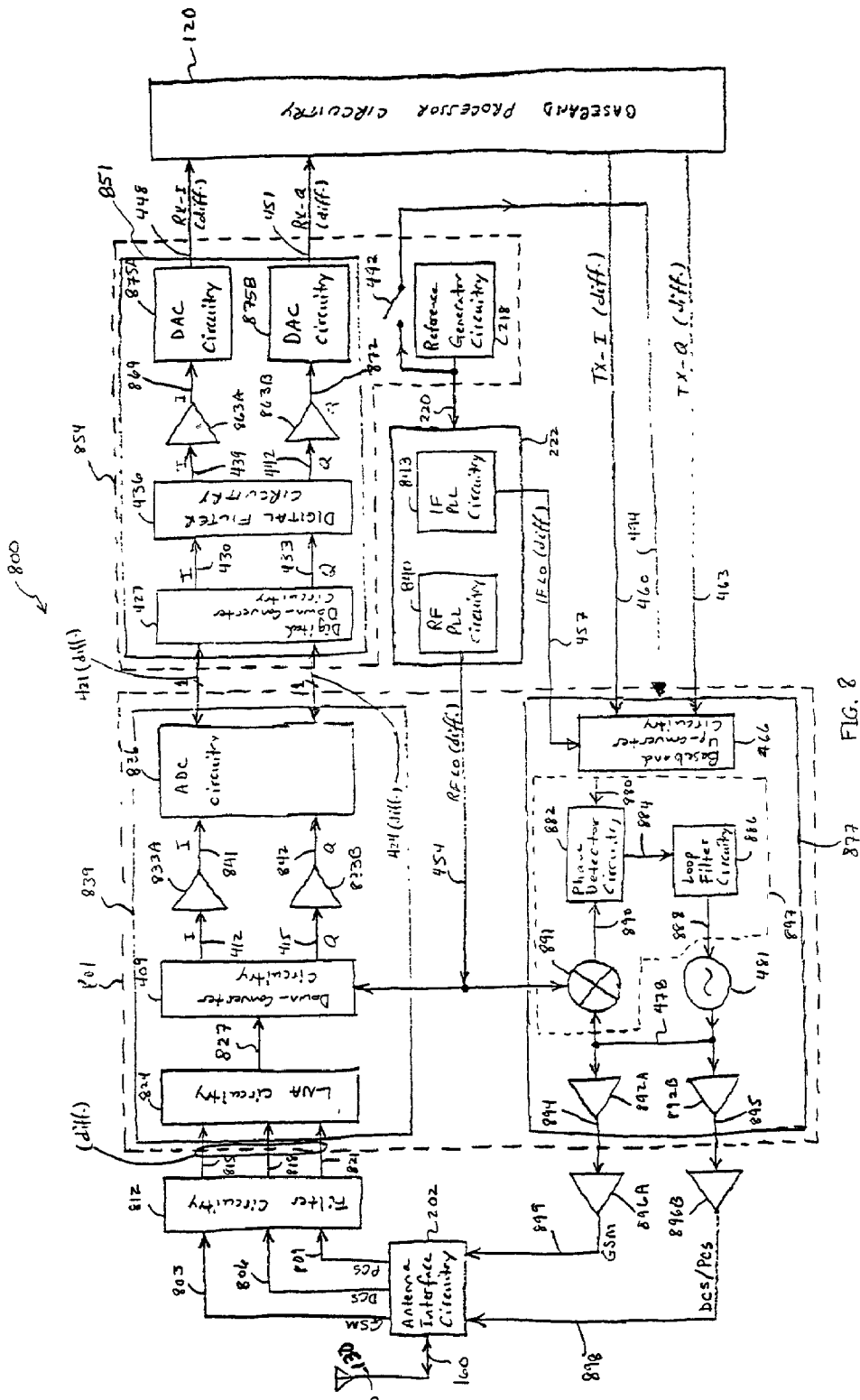

FIG. 8

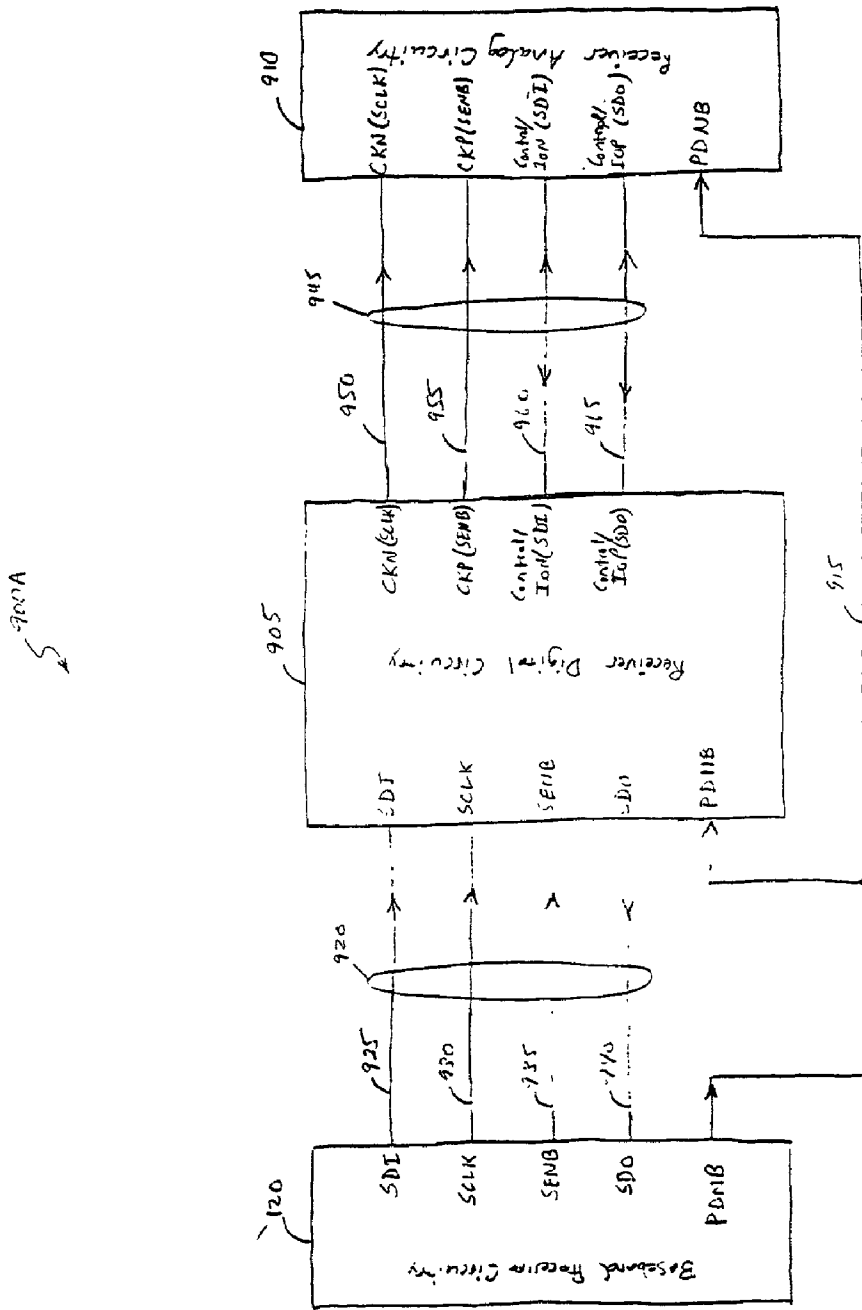

FIG. 9A

900B

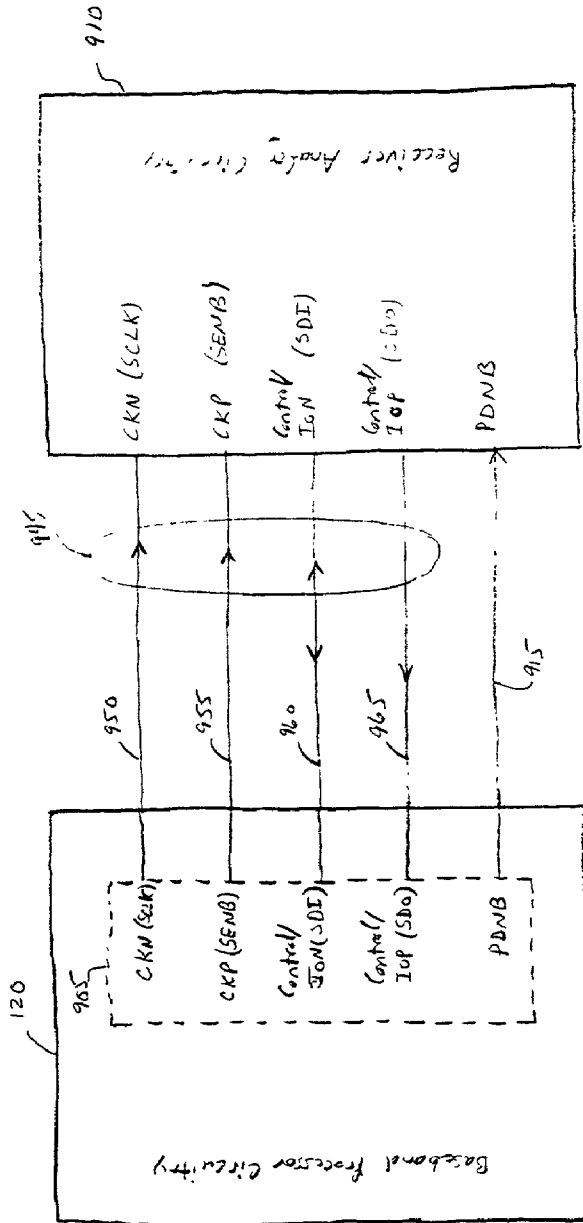

FIG. 9B

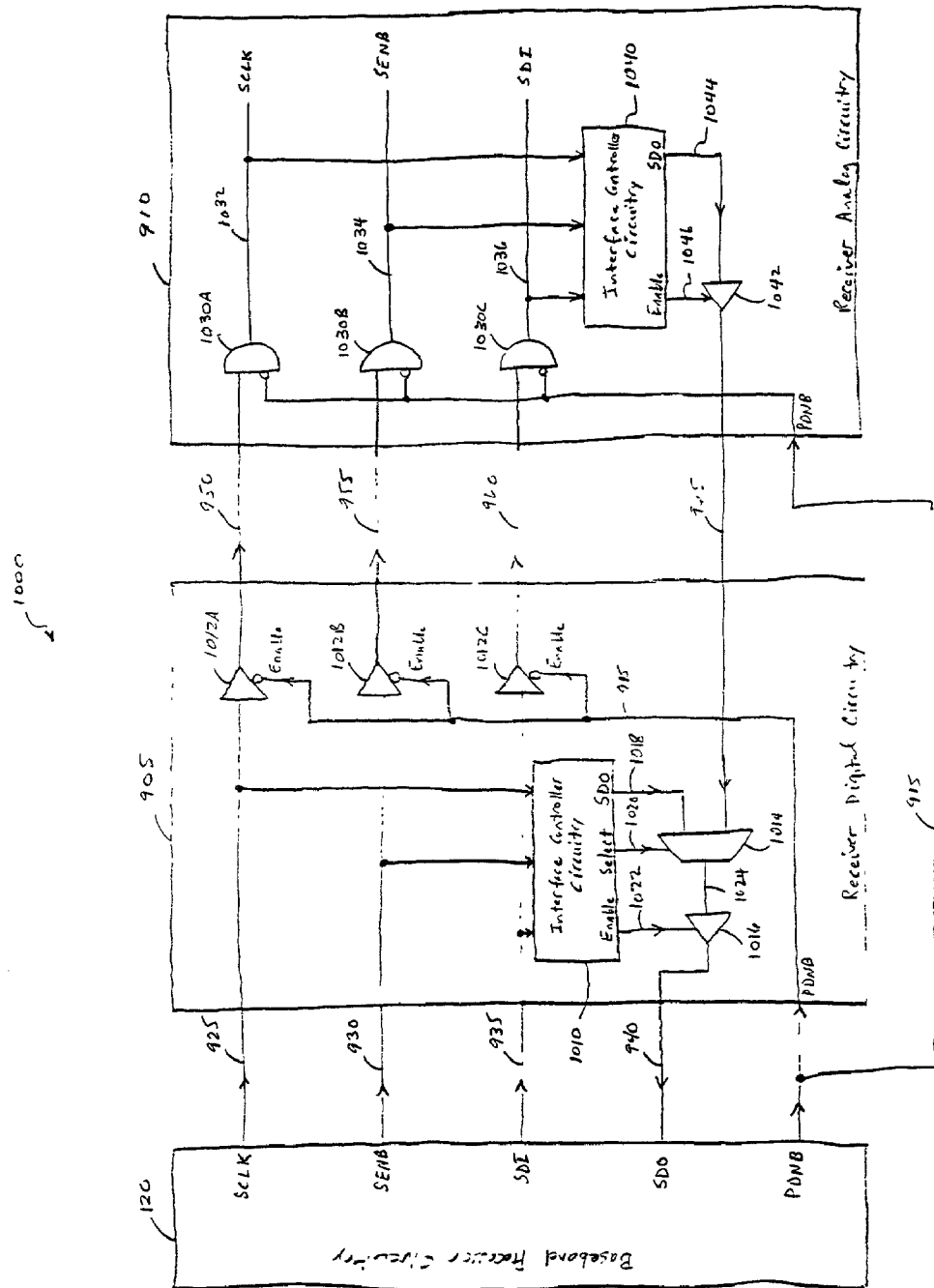

FIG. 10

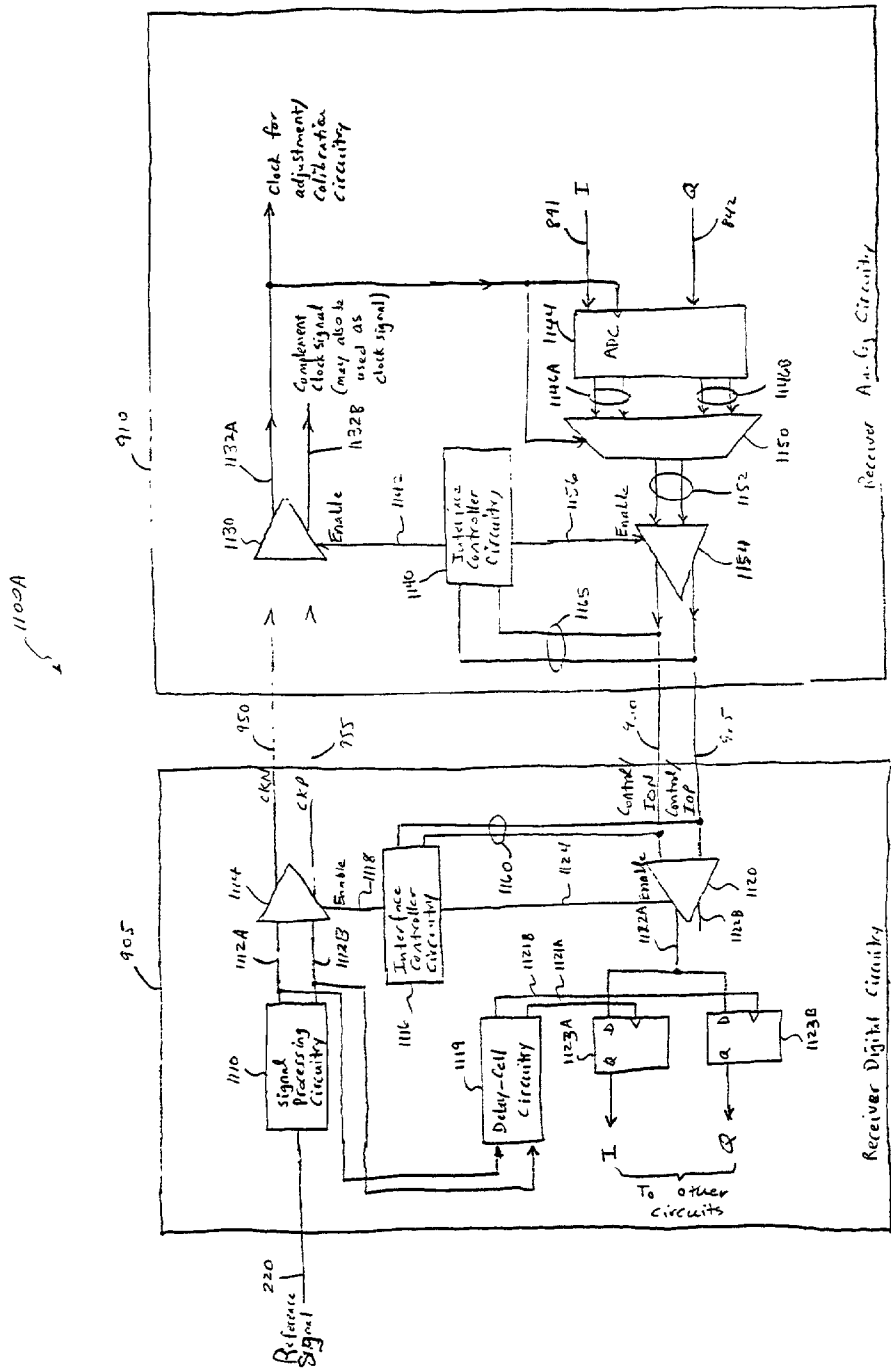

FIG. 11A

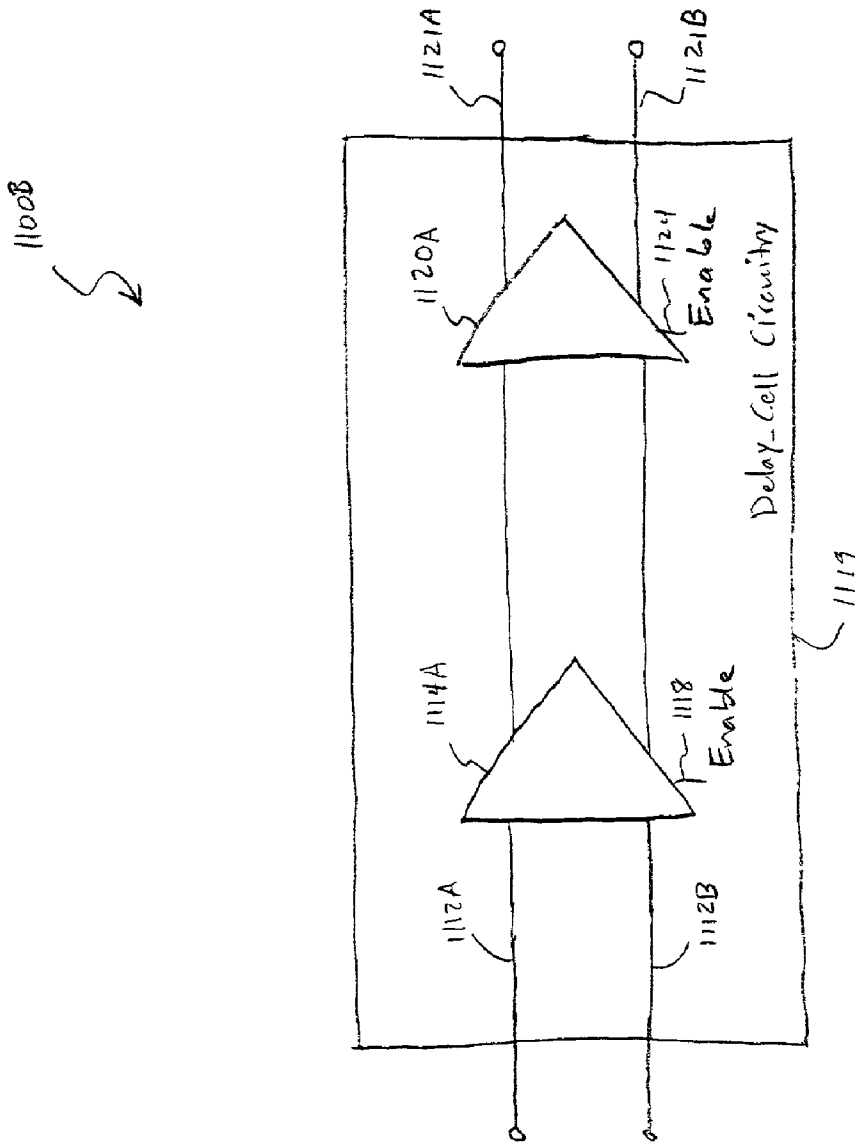

FIG. 11B

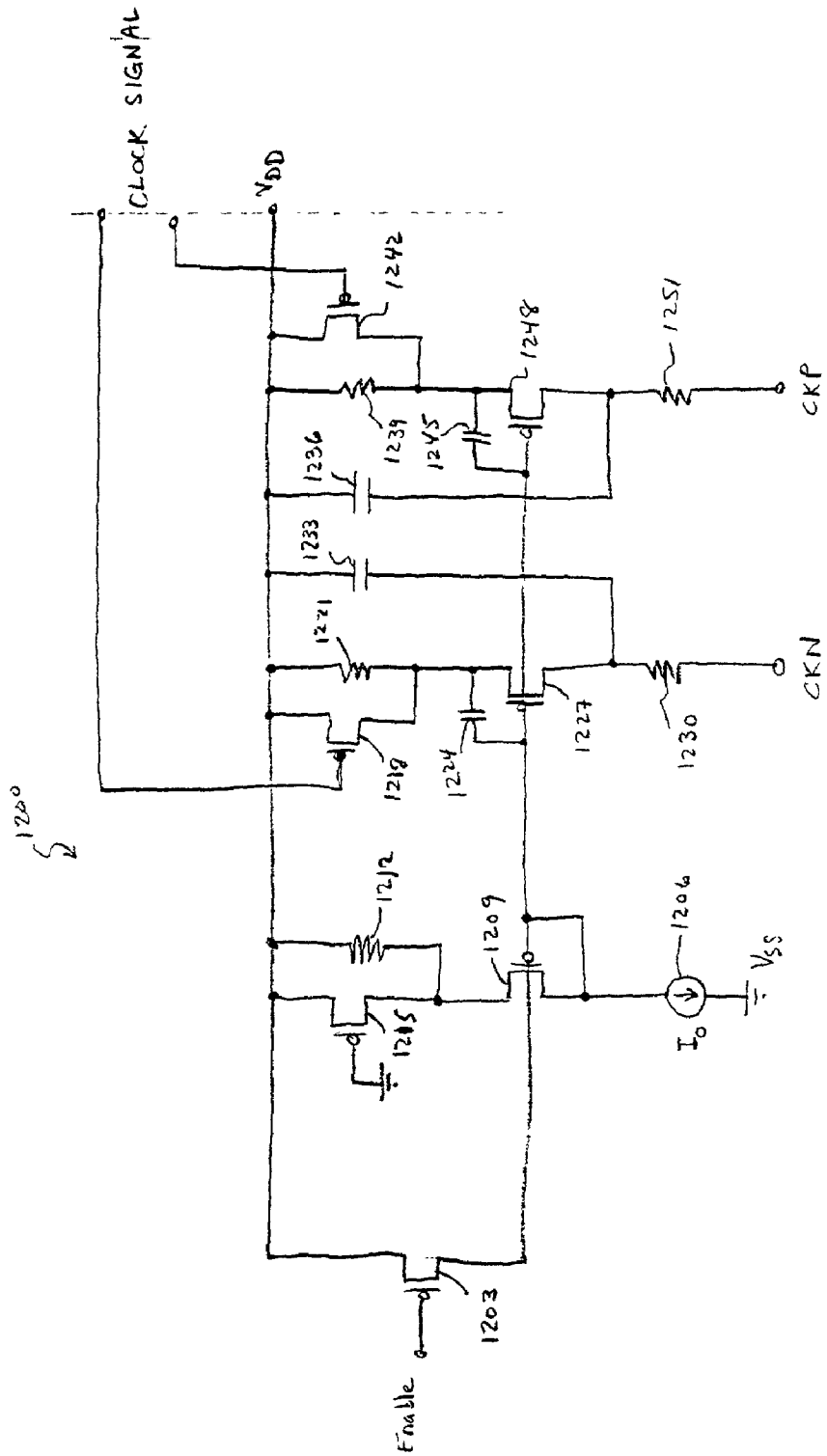

FIG. 12

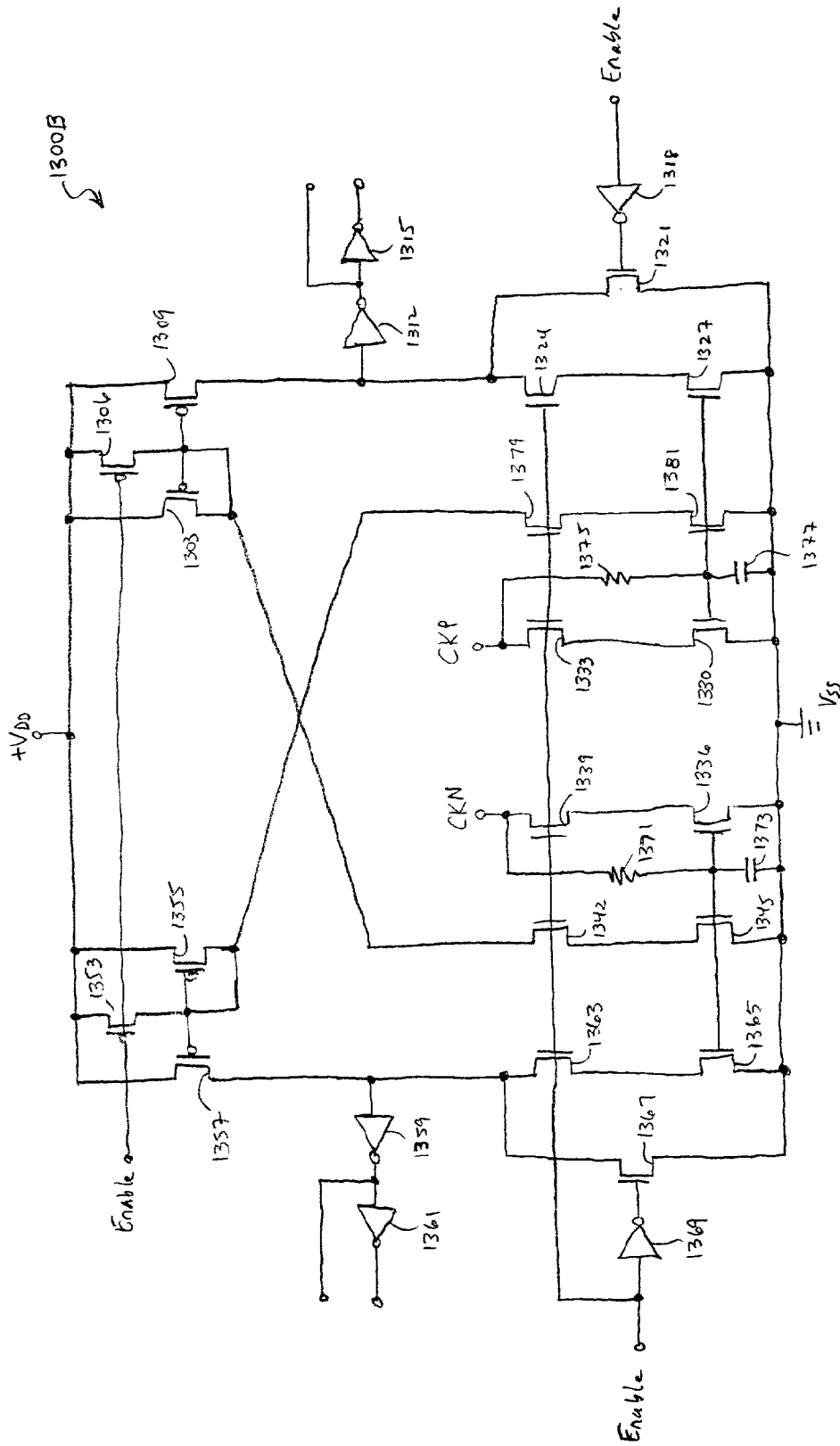

FIG. 13B

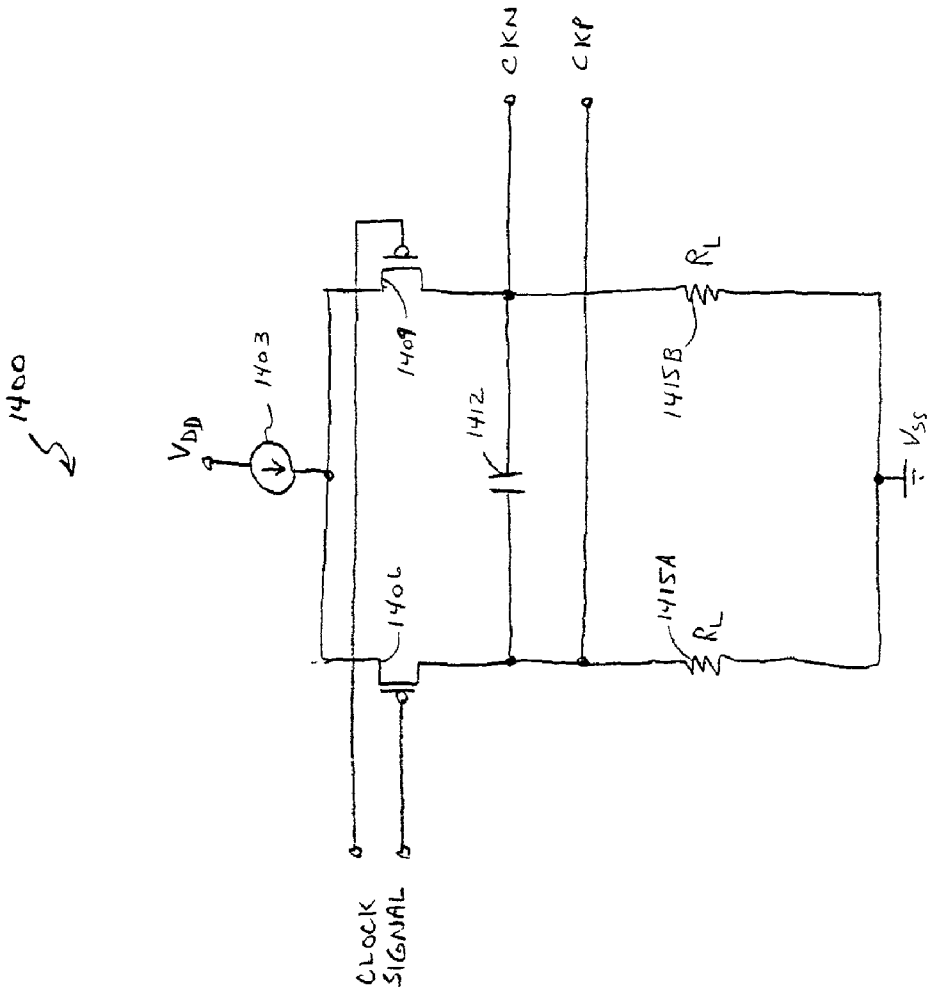

FIG. 14

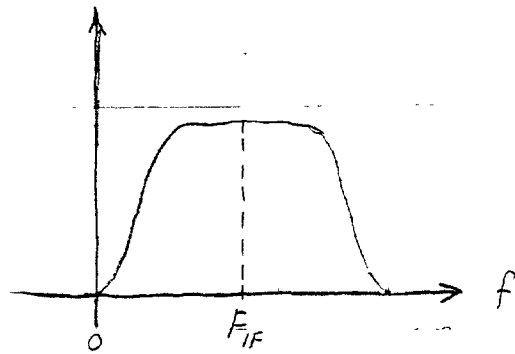

FIG. 15

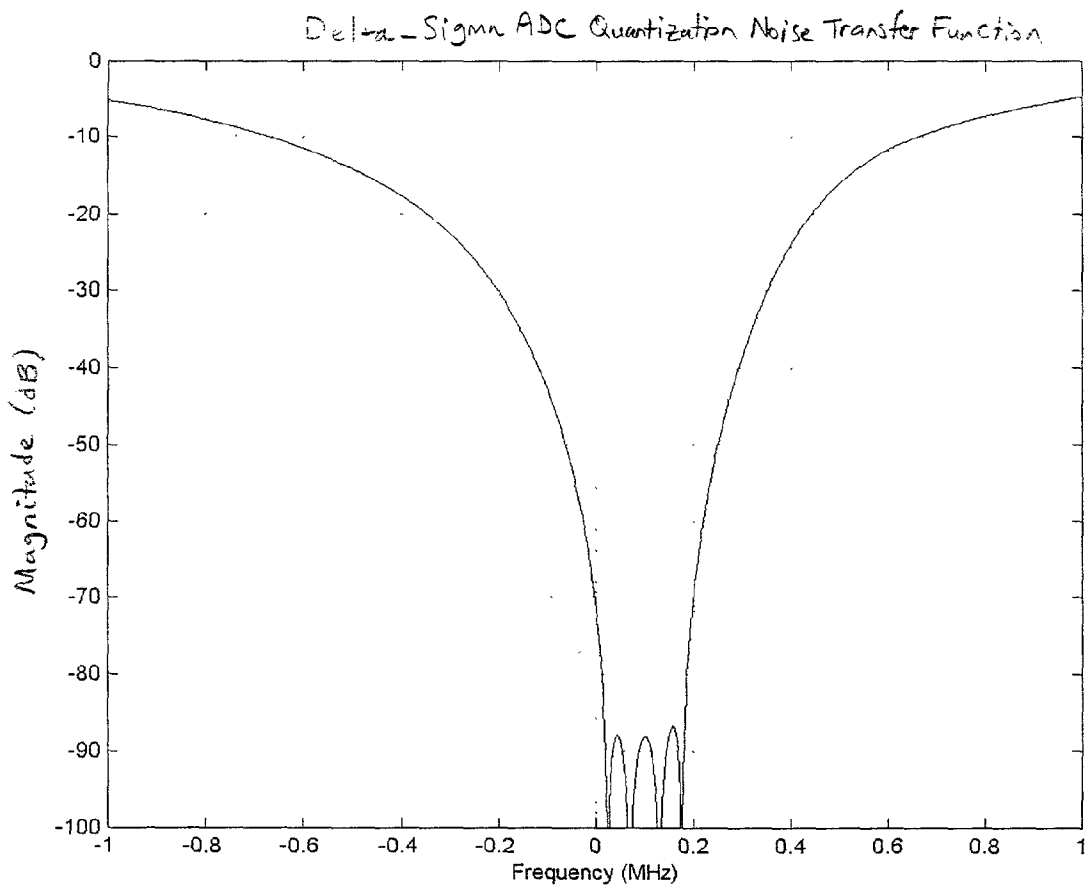

FIG. 16

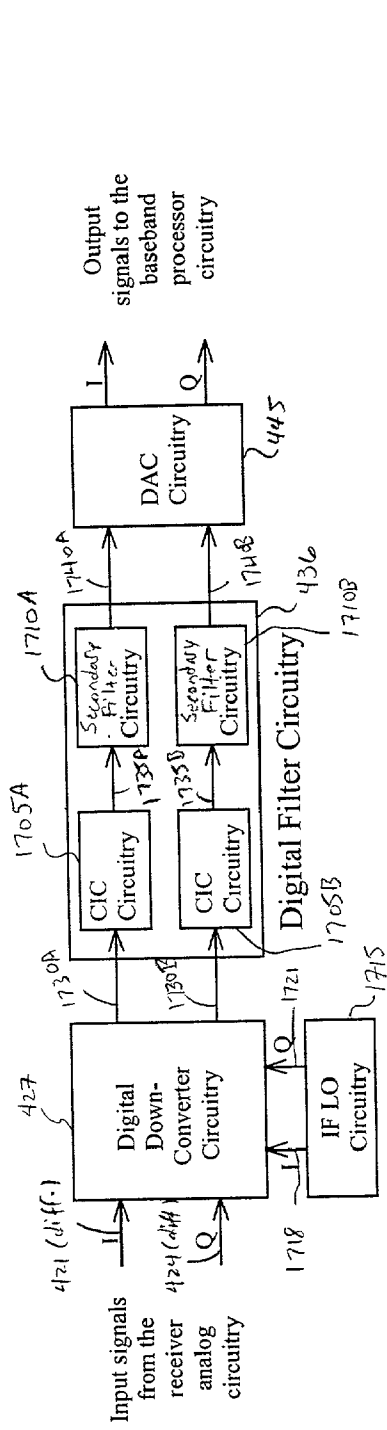

FIG. 17A

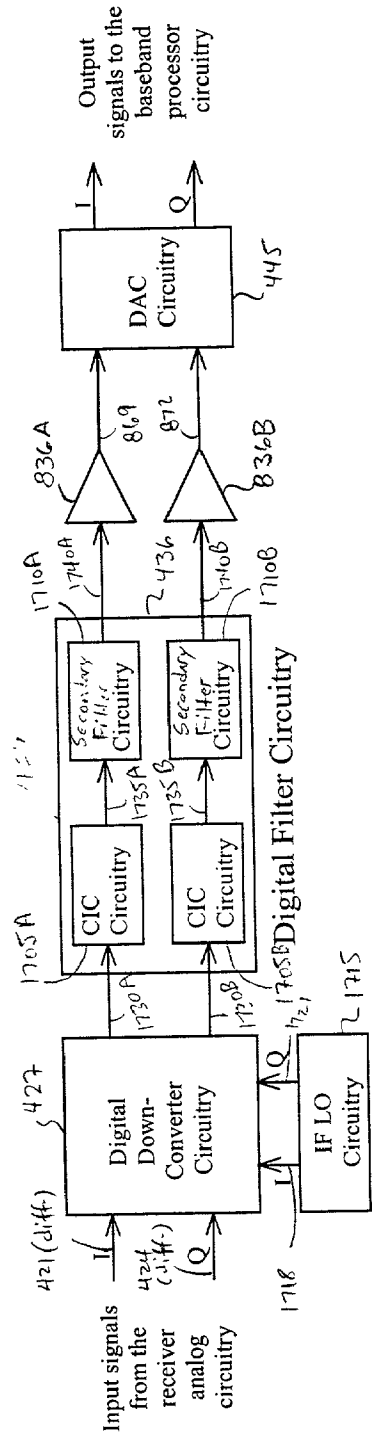

FIG. 17B

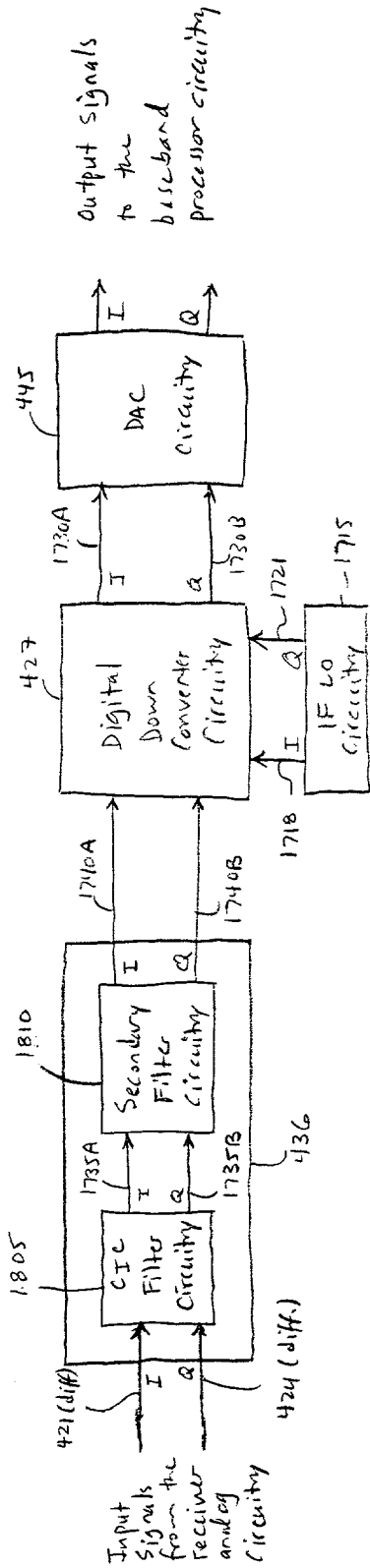

FIG. 18A

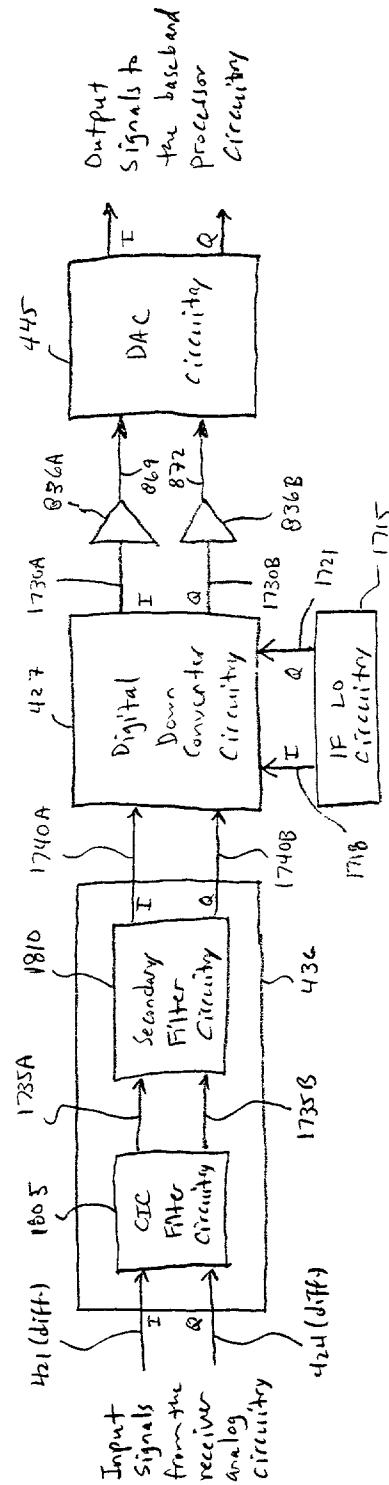

FIG. 18B

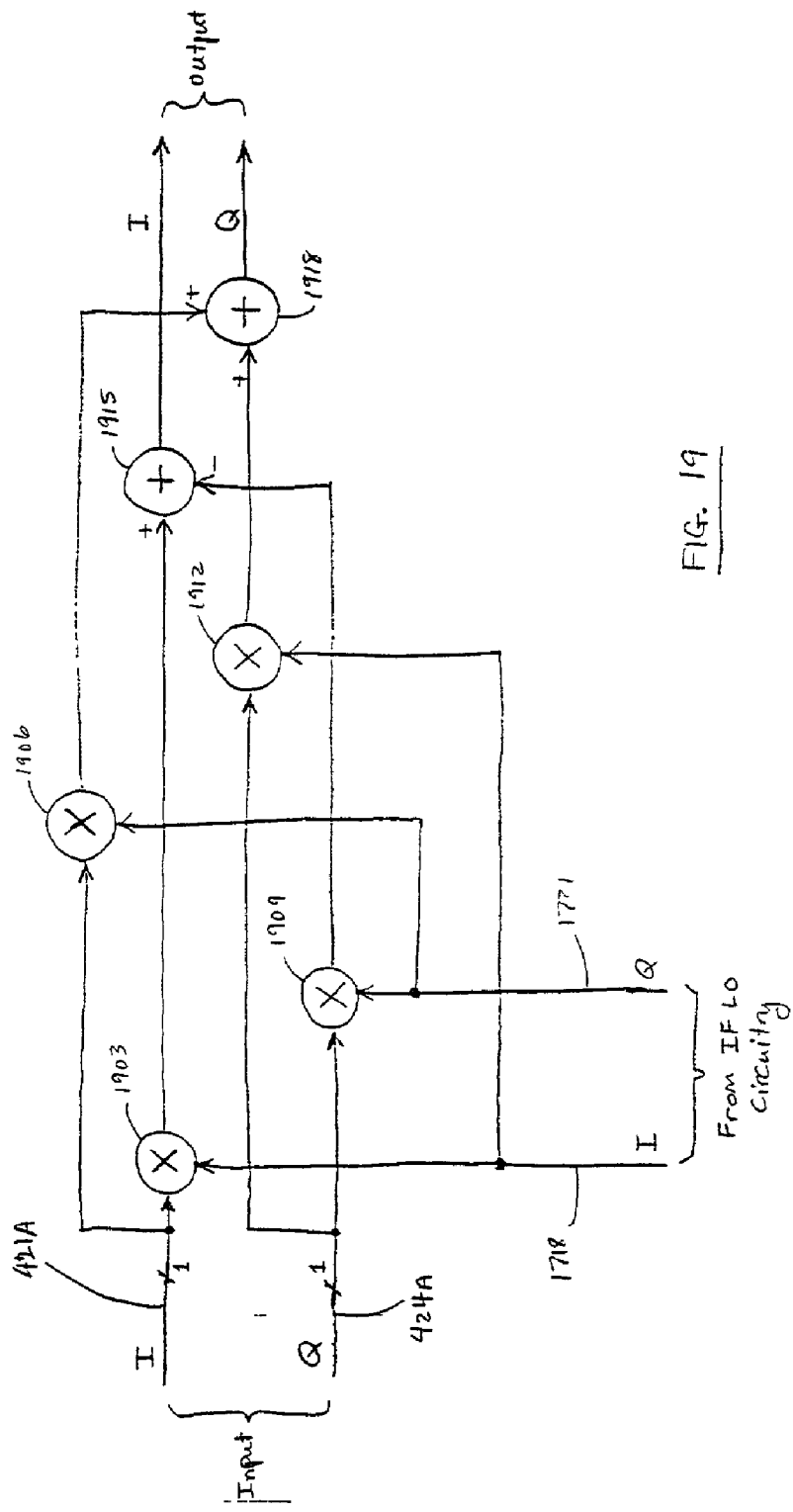

FIG. 19

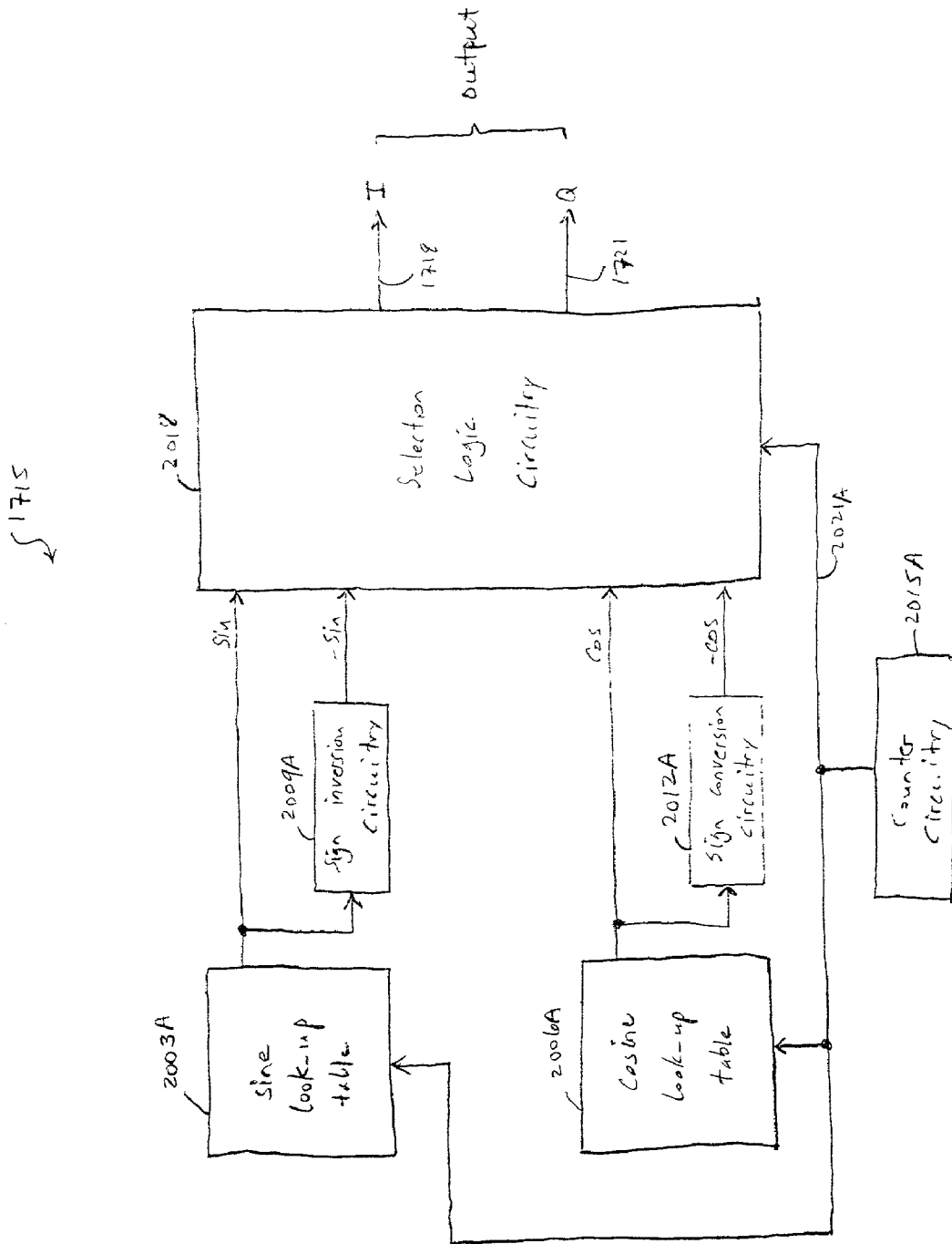

FIG. 20A

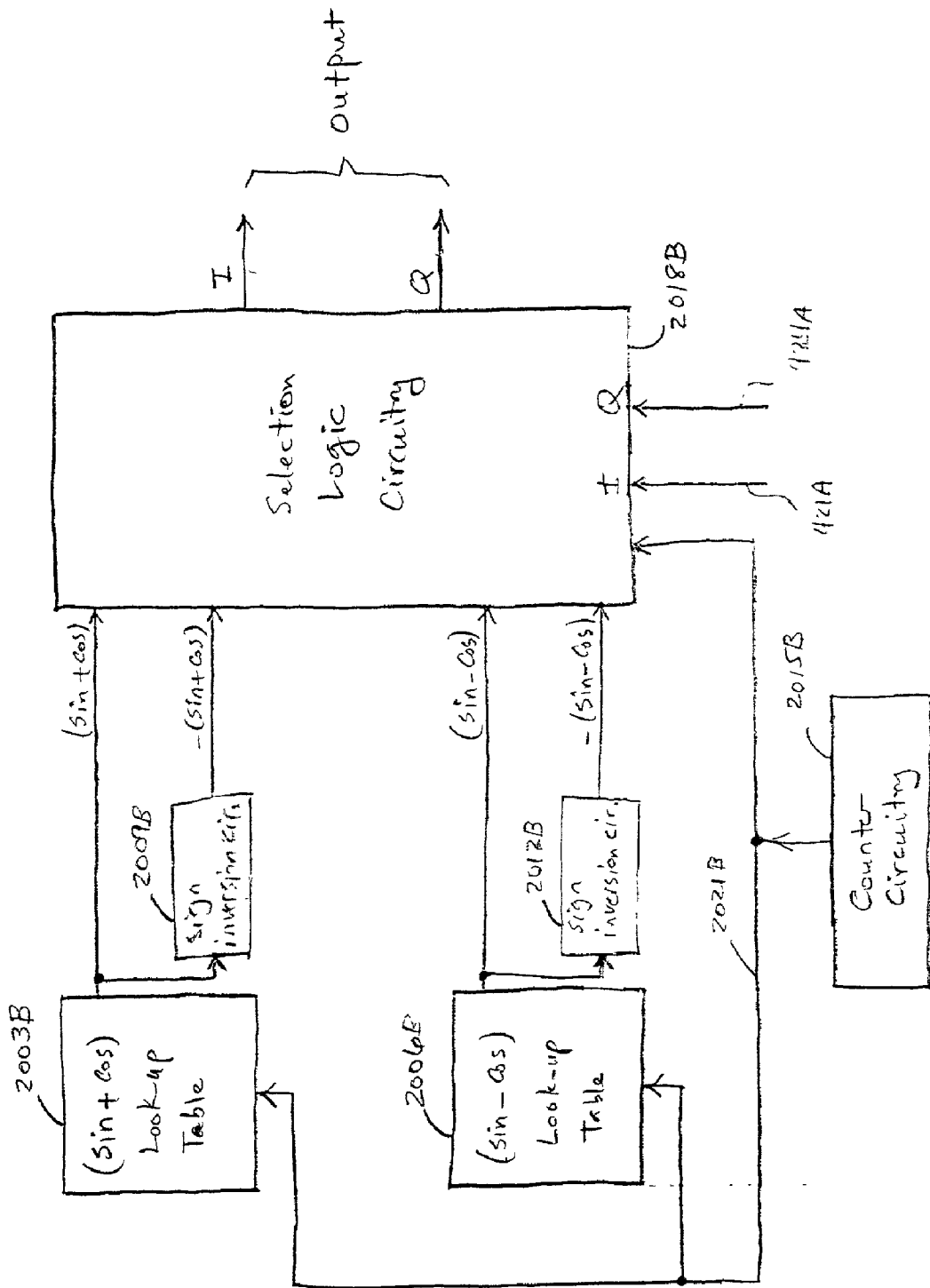

FIG. 20A

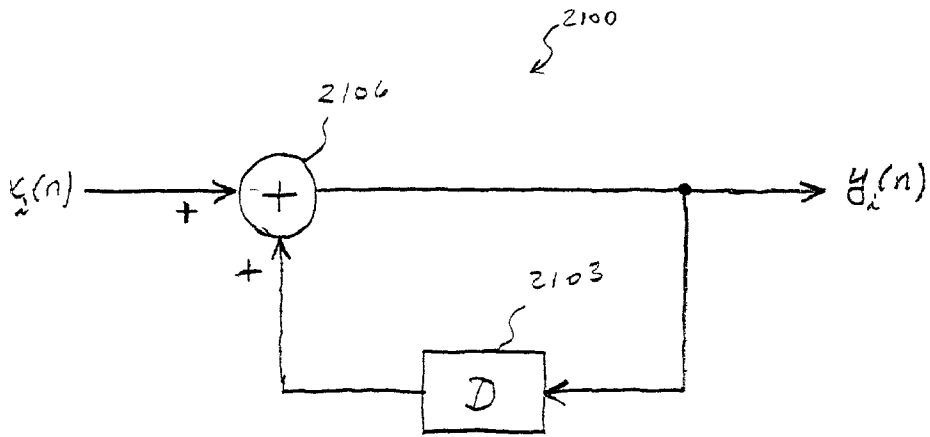

FIG. 21

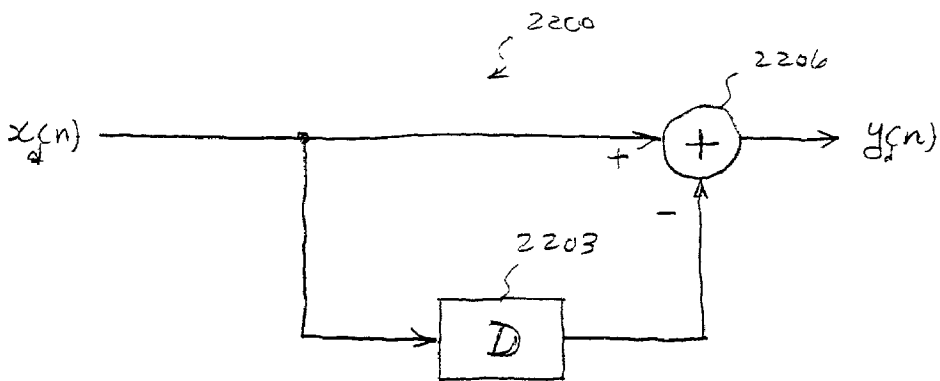

FIG. 22

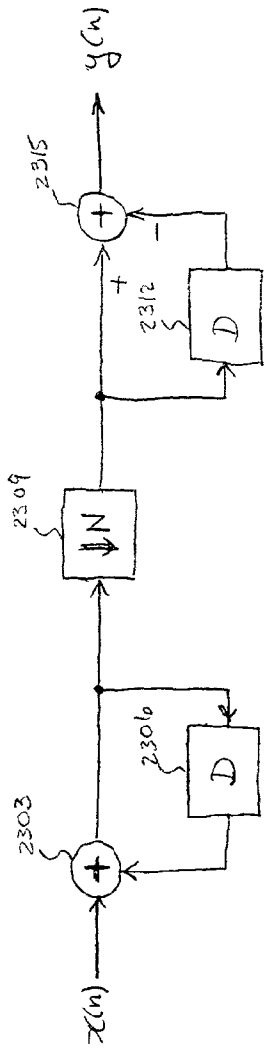

FIG. 23

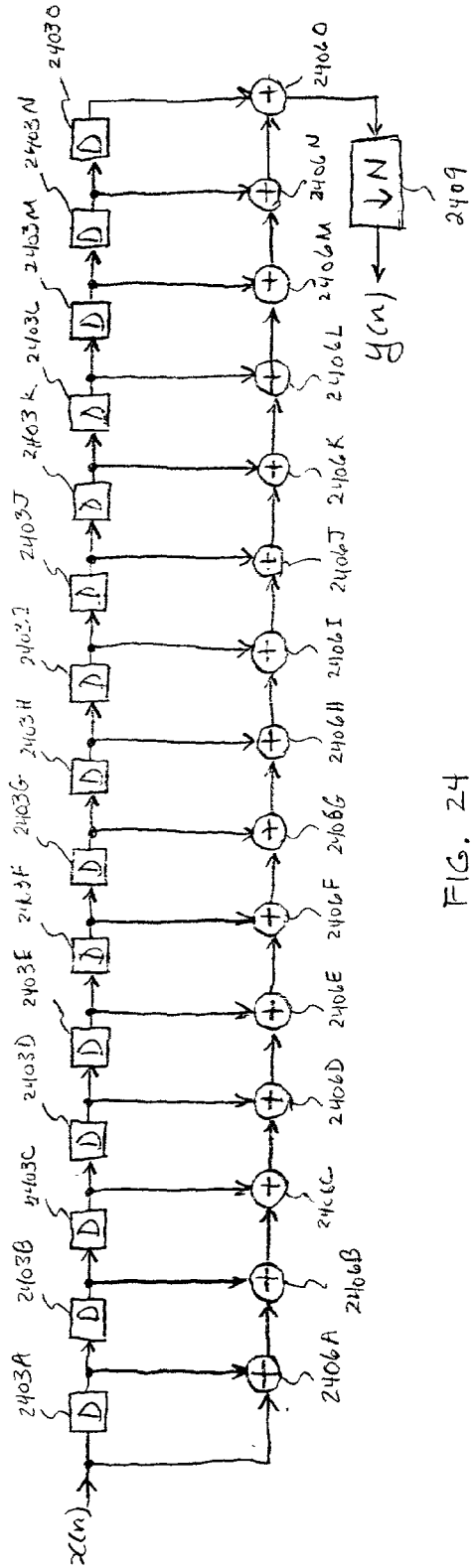

FIG. 24

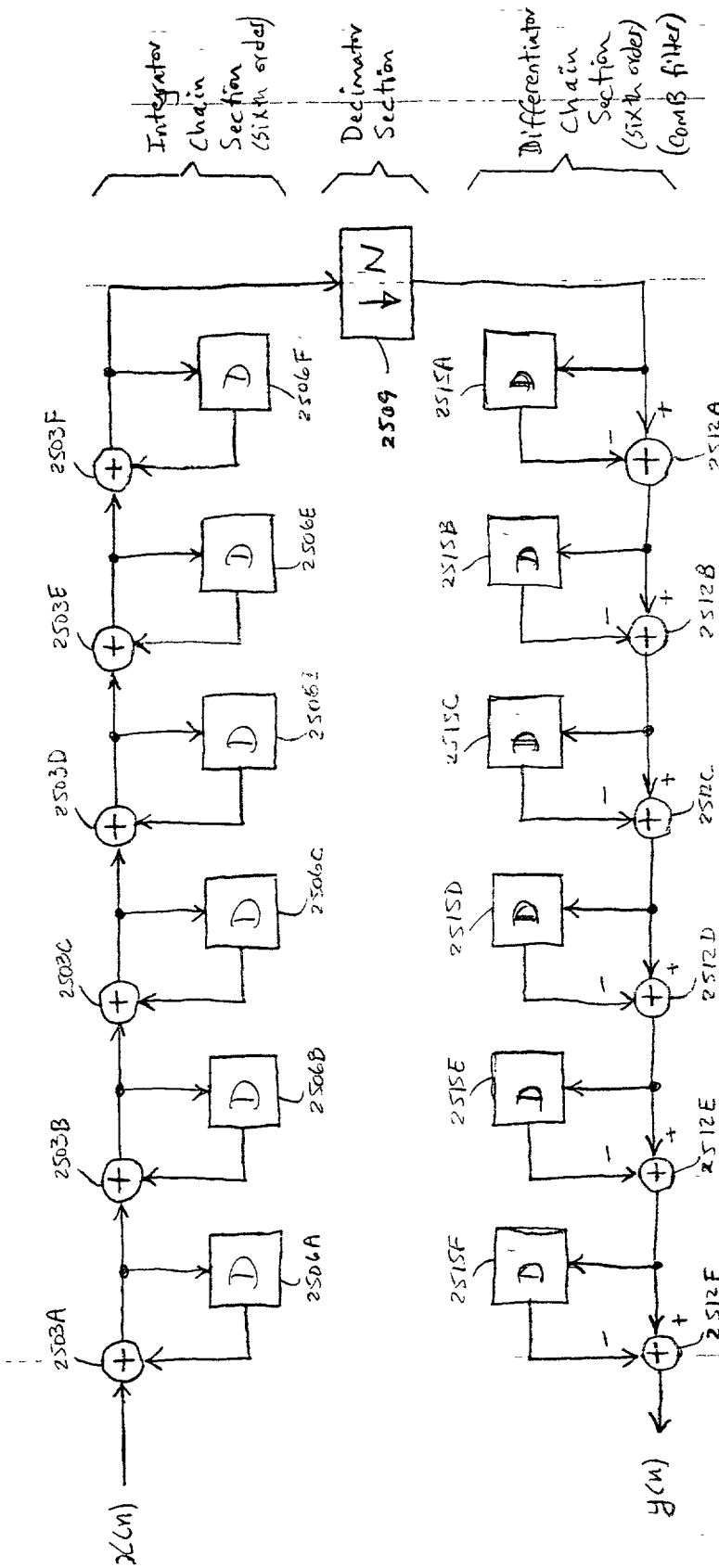

FIG. 25

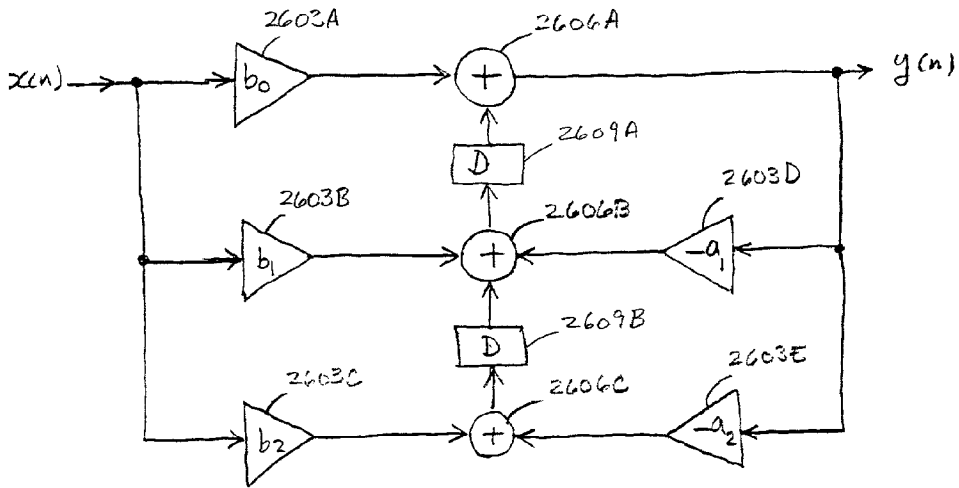

FIG. 26

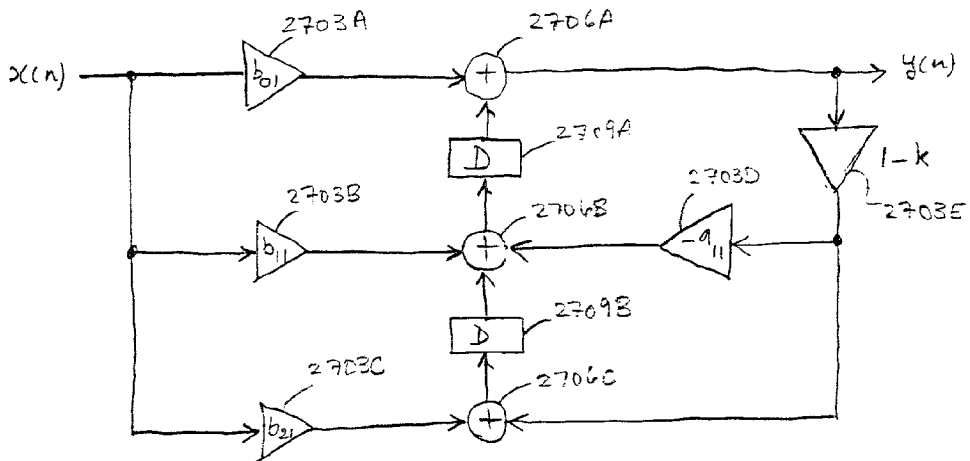

FIG. 27

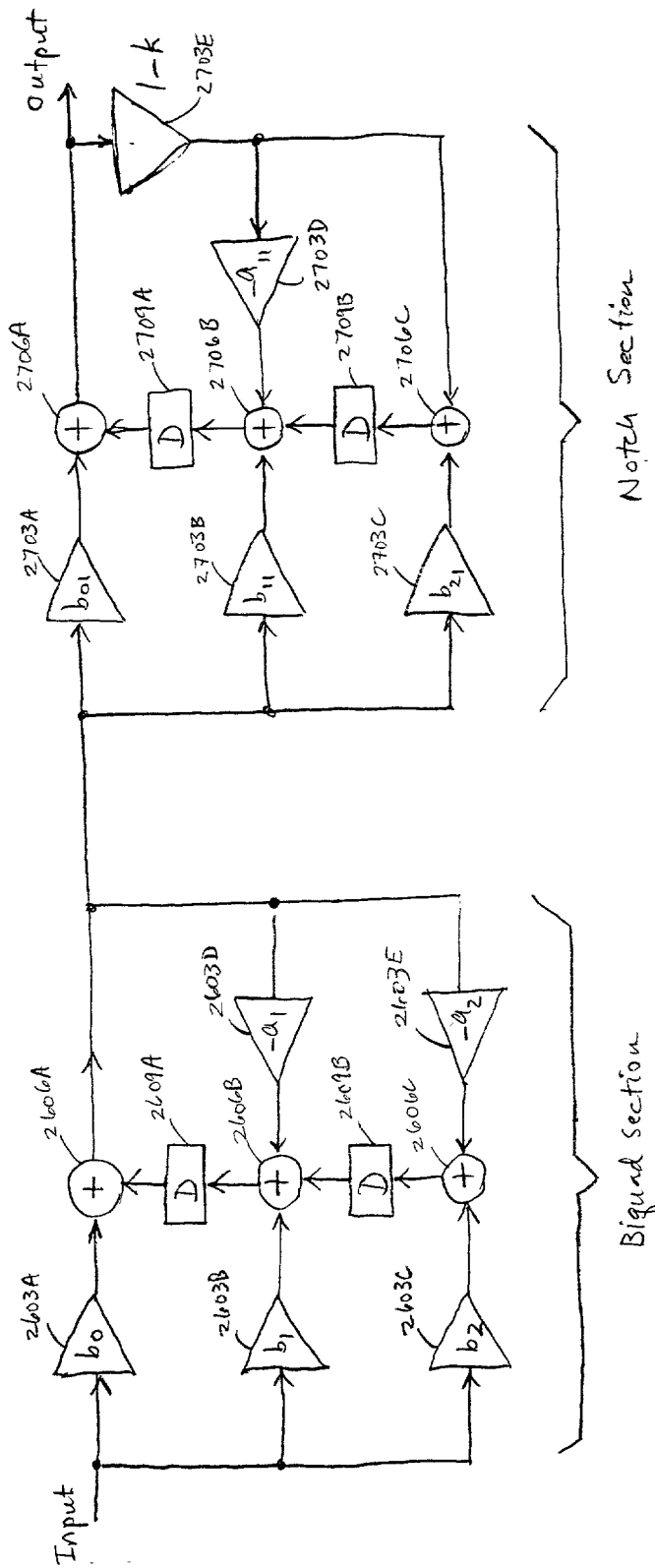

FIG. 28A

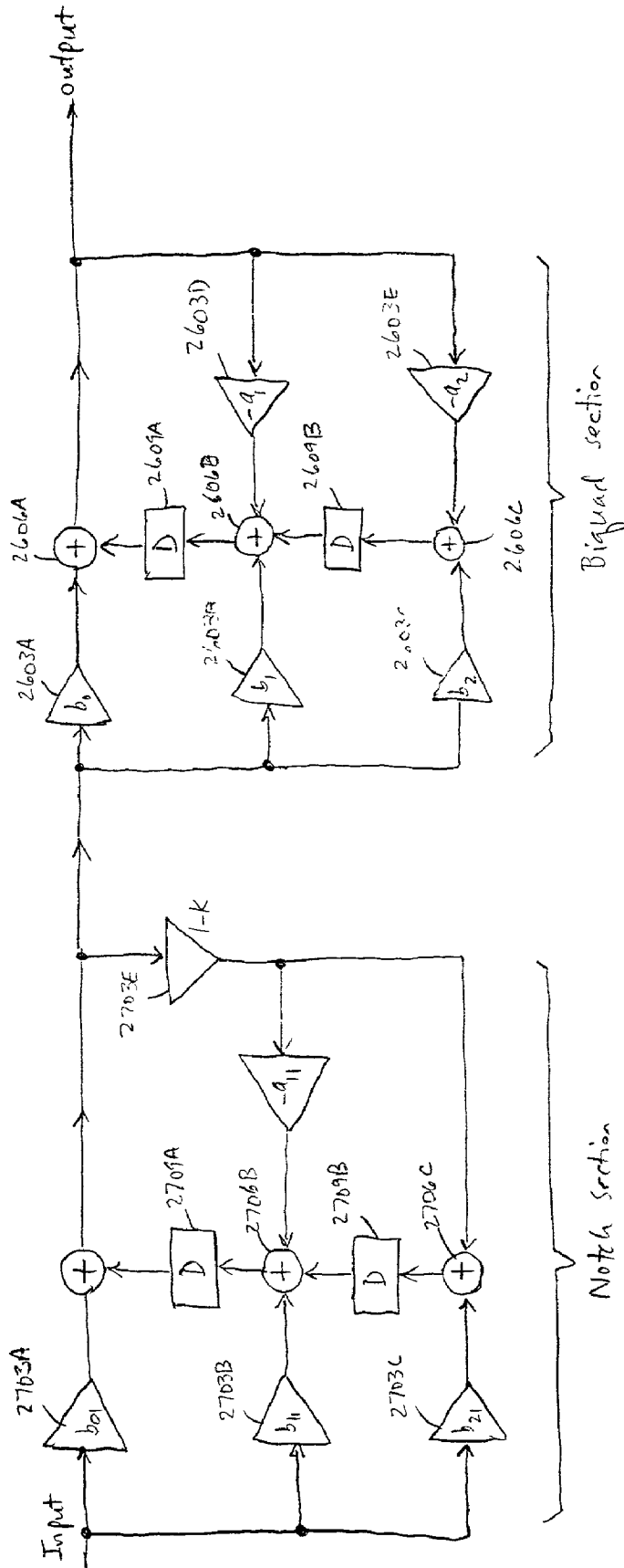

FIG. 28B

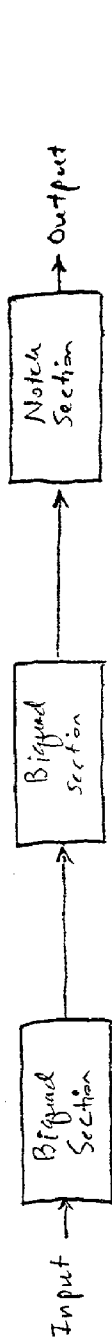

FIG. 29A



FIG. 29B



FIG. 29C

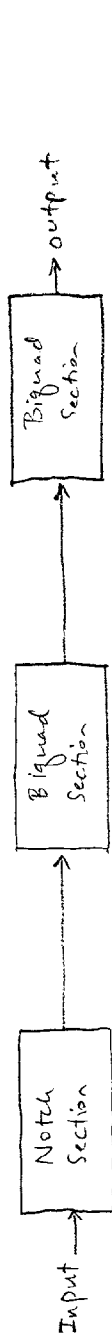

FIG. 29D

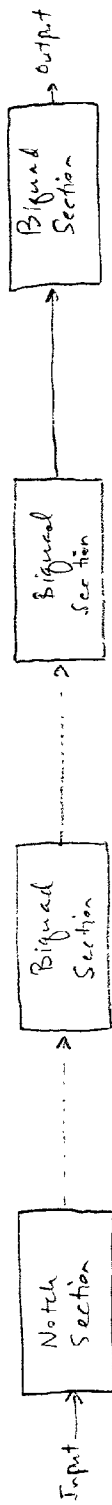

FIG. 29E

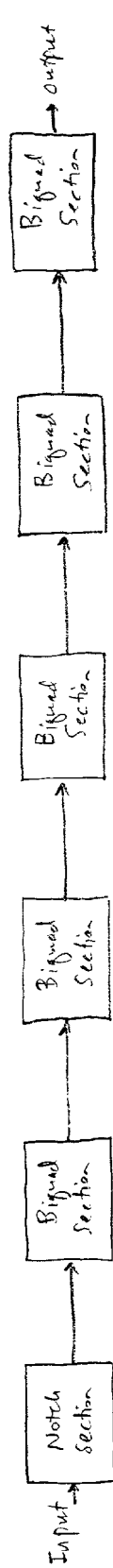

FIG. 29F

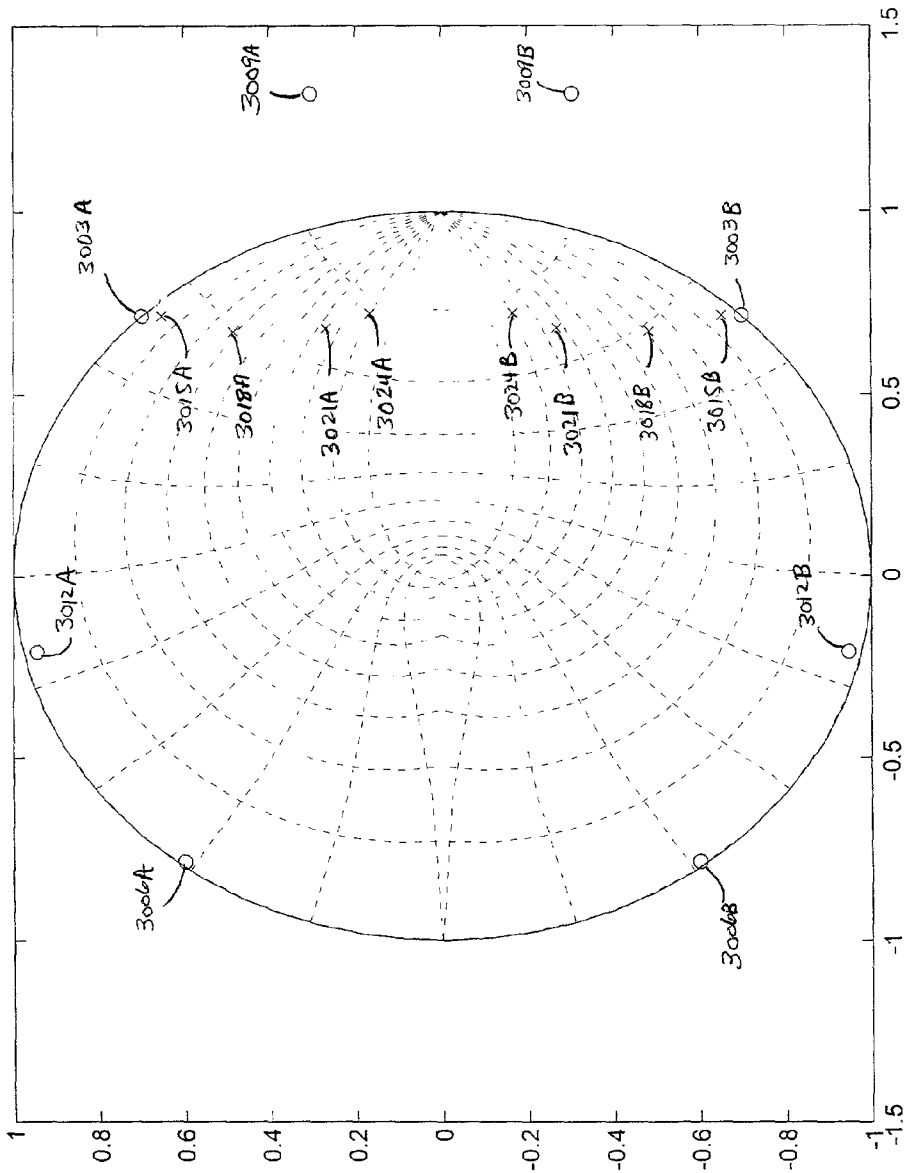

FIG. 30A

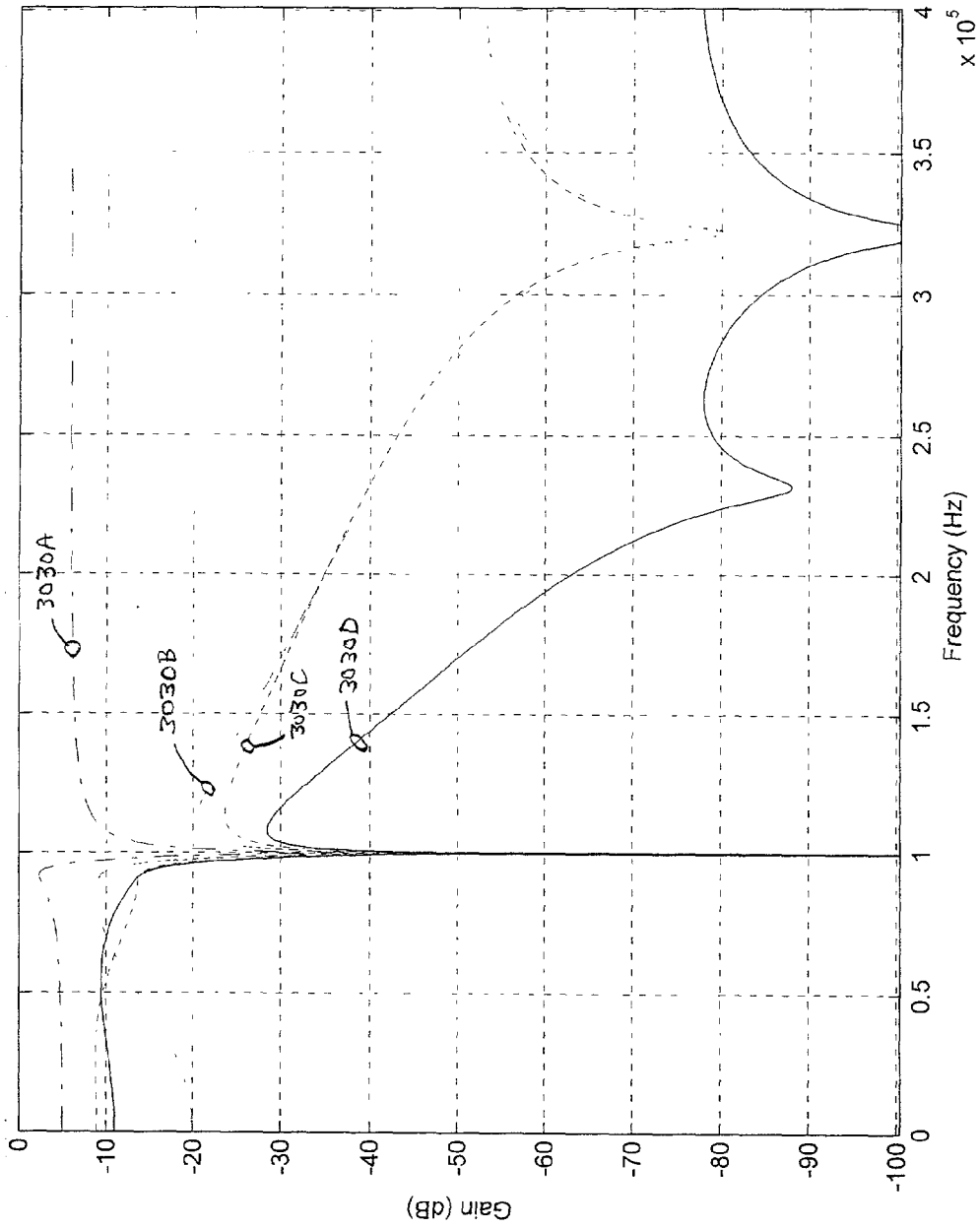

FIG. 30B

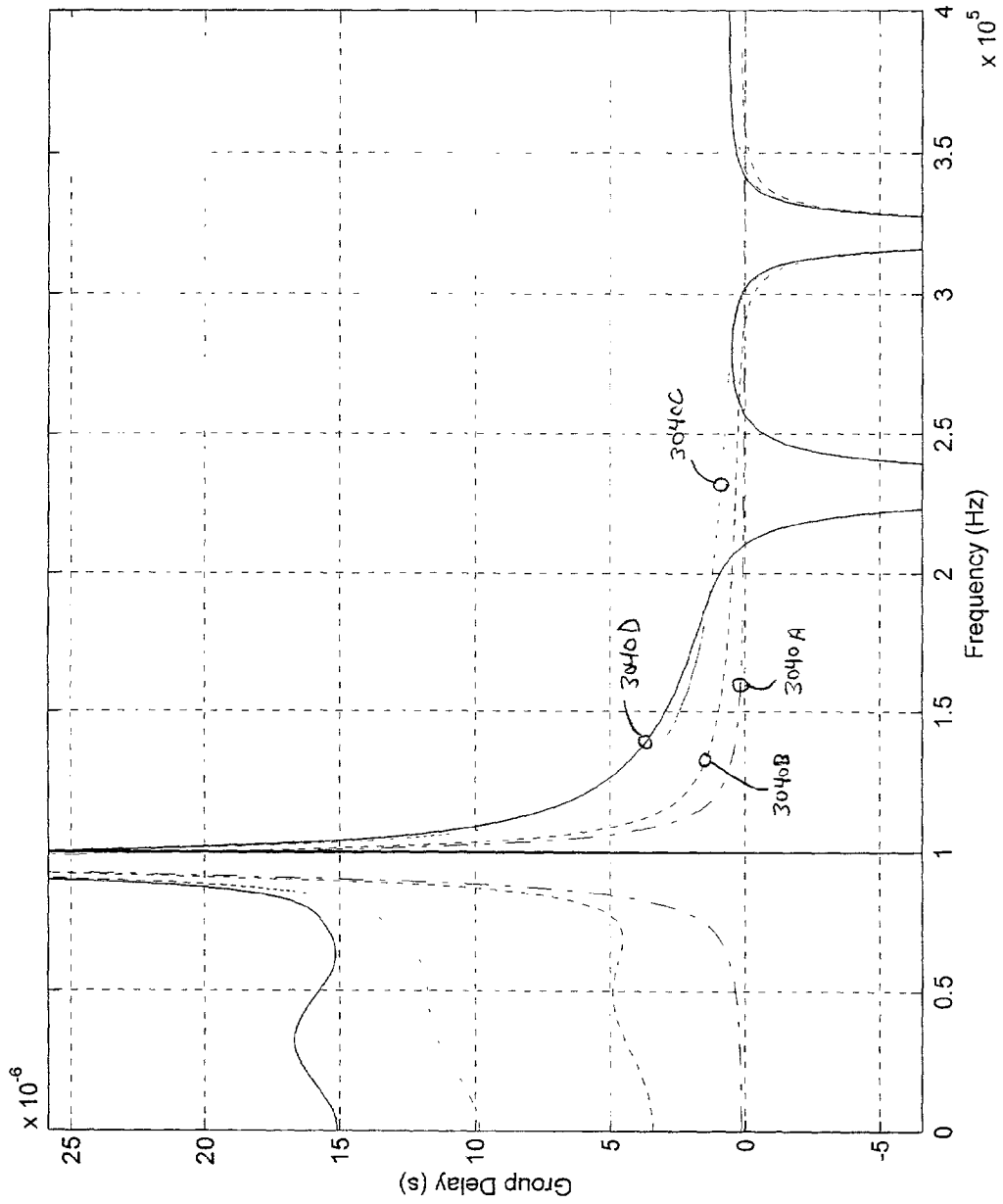

FIG. 30C

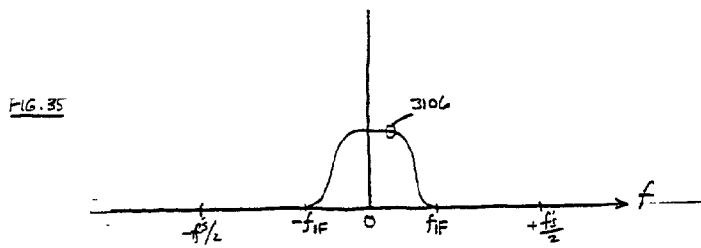
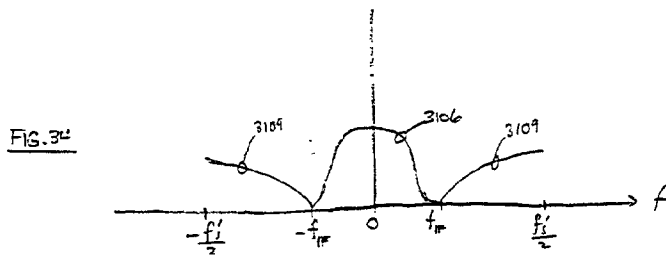
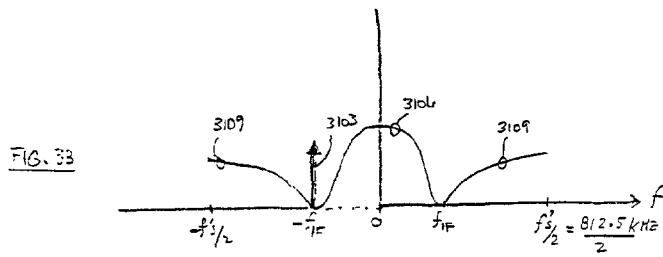
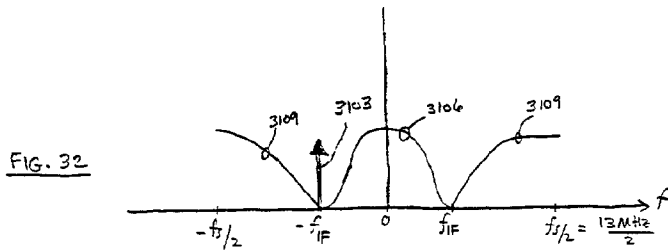
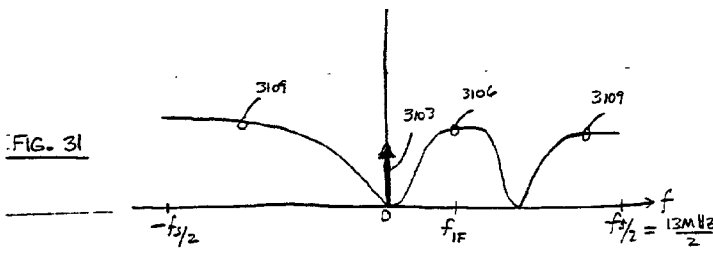

FIG. 36A

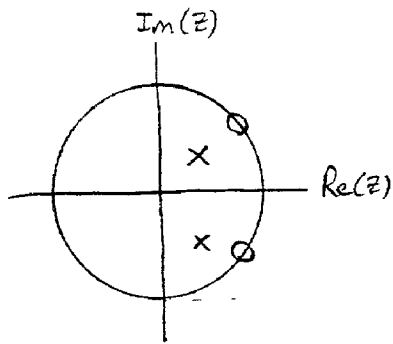

FIG. 36B

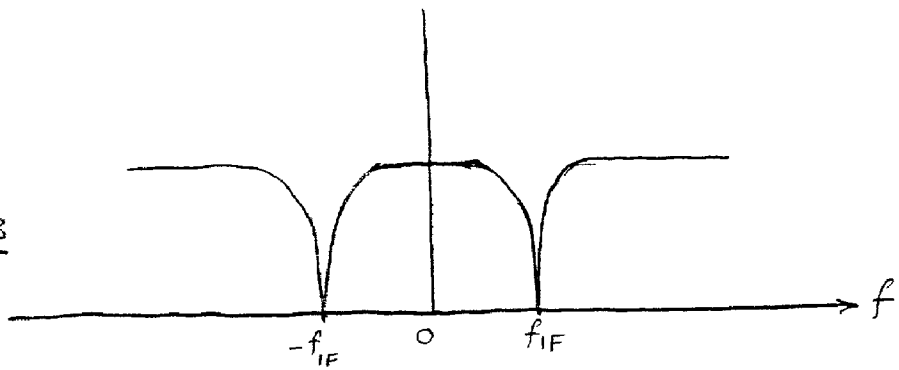

FIG. 37A

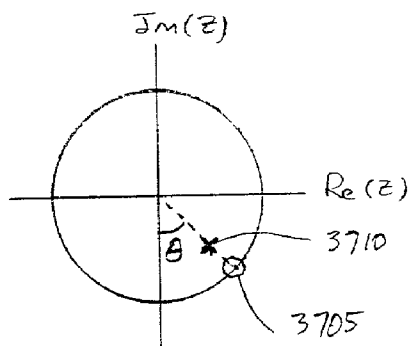
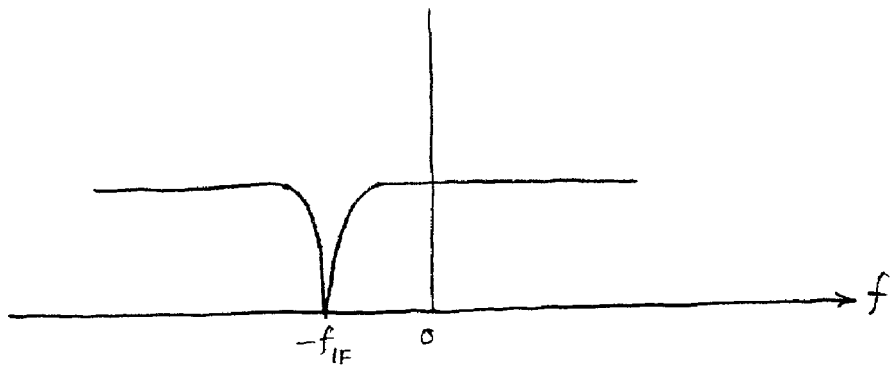

FIG. 37B



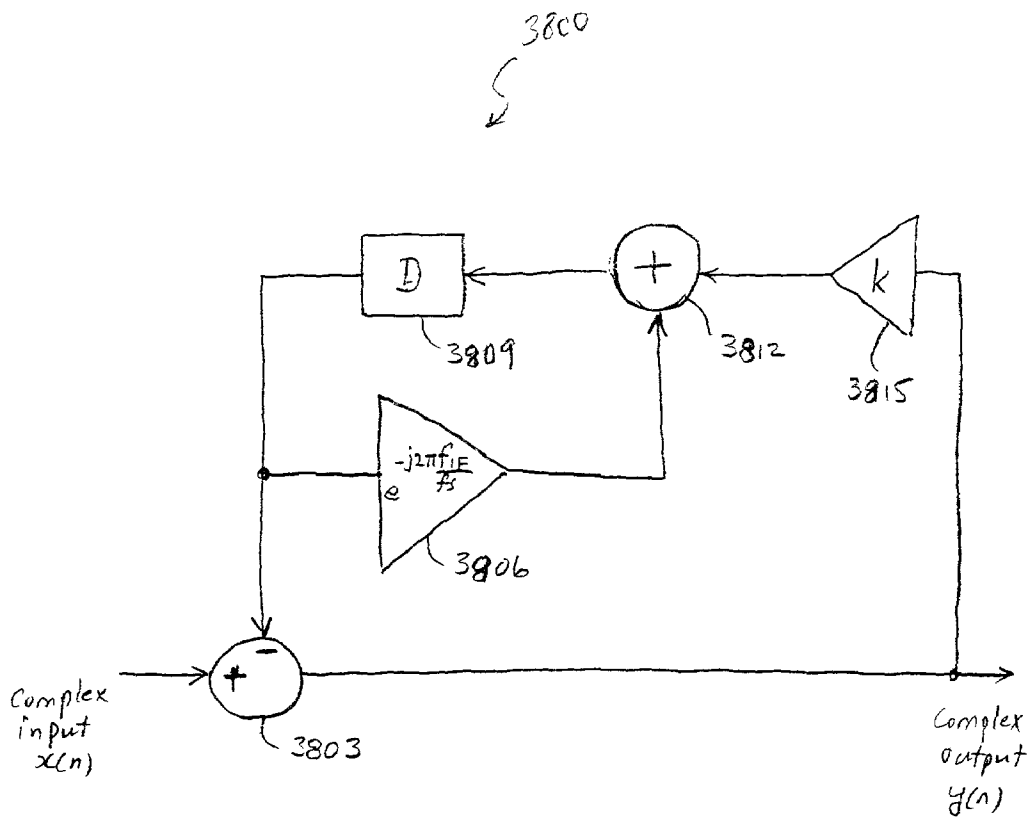

FIG. 38

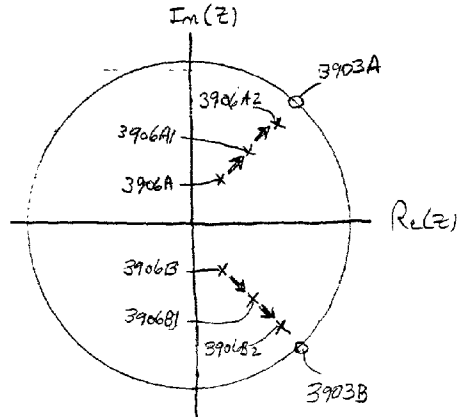

FIG. 39

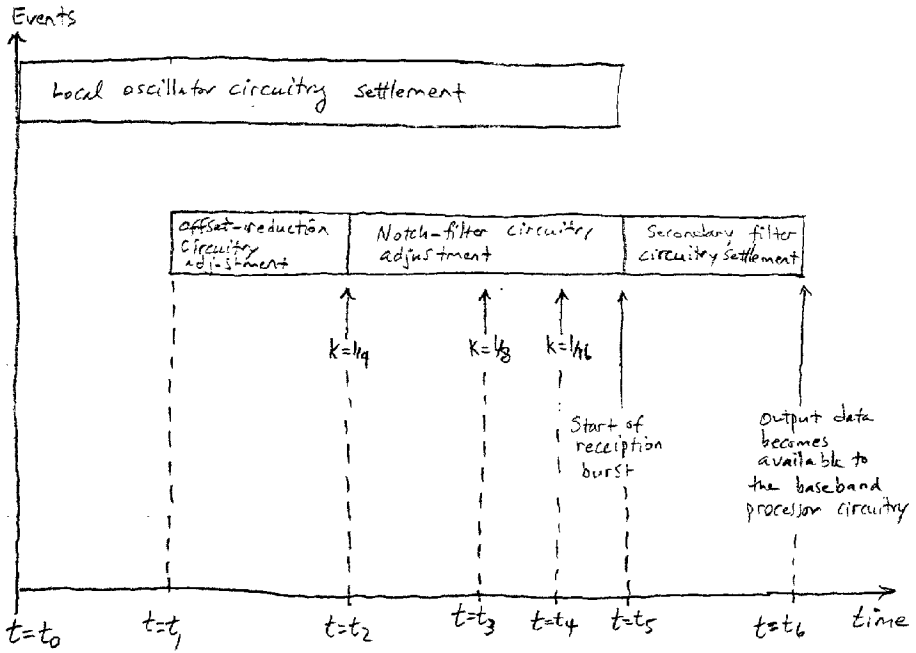

FIG. 40

NOTCH FILTER FOR DC OFFSET REDUCTION IN RADIO-FREQUENCY APPARATUS AND ASSOCIATED METHODS

CROSS-REFERENCE TO RELATED APPLICATIONS

[0001] This patent application is a continuation-in-part of U.S. patent application Ser. No. 09/821,342, Attorney Docket No. SILA:072, titled "Partitioned Radio-Frequency Apparatus and Associated Methods," and filed on Mar. 29, 2001. This patent application claims priority to Provisional U.S. patent application Ser. No. 60/261,506, Attorney Docket No. SILA:072PZ1, filed on Jan. 12, 2001; Provisional U.S. patent application Ser. No. 60/273,119, Attorney Docket No. SILA:072PZ2, titled "Partitioned RF Apparatus with Digital Interface and Associated Methods," and filed on Mar. 2, 2001; and Provisional U.S. patent application Ser. No. 60/333,520, filed on Nov. 27, 2001.

[0002] Furthermore, this patent application incorporates by reference the following patent documents: U.S. patent application Ser. No. _____, Attorney Docket No. SILA:078, titled "Digital Architecture for Radio-Frequency Apparatus and Associated Methods"; and U.S. patent application Ser. No. _____, Attorney Docket No. SILA:098, titled "DC Offset Reduction in Radio-Frequency Apparatus and Associated Methods."

TECHNICAL FIELD OF THE INVENTION

[0003] This invention relates to radio-frequency (RF) receivers and transceivers. More particularly, the invention concerns a (i) digital architecture for RF receiver or transceiver circuitry, and (ii) notch filter circuitry and architecture for offset reduction in the RF receiver or transceiver circuitry.

BACKGROUND

[0004] The proliferation and popularity of mobile radio and telephony applications has led to market demand for communication systems with low cost, low power, and small form-factor radio-frequency (RF) transceivers. As a result, recent research has focused on providing monolithic transceivers using low-cost complementary metal-oxide semiconductor (CMOS) technology. One aspect of research efforts has focused on providing an RF transceiver within a single integrated circuit (IC). The integration of transceiver circuits is not a trivial problem, as it must take into account the requirements of the transceiver's circuitry and the communication standards governing the transceiver's operation. From the perspective of the transceiver's circuitry, RF transceivers typically include sensitive components susceptible to noise and interference with one another and with external sources. Integrating the transceiver's circuitry into one integrated circuit may exacerbate interference among the various blocks of the transceiver's circuitry. Moreover, communication standards governing RF transceiver operation outline a set of requirements for noise, inter-modulation, blocking performance, output power, and spectral emission of the transceiver.

[0005] Unfortunately, no known technique for addressing all of the above issues in high-performance RF receivers or transceivers, for example, RF transceivers used in cellular and telephony applications, has been developed. A need

therefore exists for techniques of partitioning and integrating RF receivers or transceivers that would provide low-cost, low form-factor RF transceivers for high-performance applications, for example, in cellular handsets.

[0006] A further aspect of RF receivers and transceivers relates to providing high-performance signal processing functions in an integrated form. Typical conventional receivers and transceivers rely on baseband processor circuitries to implement various signal processing functions, such as channelization filtering. Some baseband processor circuitries, however, do not contain their own channelization filtering. Furthermore, the system designer may choose to not implement channelization filtering in a baseband processor circuitry in order to, for example, reduce performance requirements for data converter circuitries present in the receiver or transceiver. The migration of the signal processing functions to the baseband processor circuitry may also result in its increased complexity. Moreover, front-end analog circuitry contributes DC offsets that impact the processing of the desired signal. A further need therefore exists for RF apparatus that provide high performance signal processing functions to implement functions ranging from reduction or cancellation of DC offsets to signal processing within the RF apparatus signal path, such as channelization filtering.

SUMMARY OF THE INVENTION

[0007] This invention relates to reducing DC offset in RF apparatus. The inventive concepts provide a solution to the problem of DC offset in RF apparatus and its adverse impact on the processing of the desired or in-band signal. One aspect of the invention concerns apparatus for DC offset reduction.

[0008] In one embodiment, a receiver digital circuitry includes a digital down-converter circuitry and a digital filter circuitry. The digital down-converter circuitry mixes a digital input signal provided by a receiver analog circuitry with a digital intermediate frequency (IF) local oscillator signal. The mixing of the two signals generates a digital down-converted signal. The digital filter circuitry filters the digital down-converted signal to generate a filtered digital signal. The digital filter circuitry provides a notch at a frequency that corresponds to a residual DC offset of the receiver analog circuitry.

DESCRIPTION OF THE DRAWINGS

[0009] The appended drawings illustrate only exemplary embodiments of the invention and therefore do not limit its scope. The disclosed inventive concepts lend themselves to other equally effective embodiments. In the drawings, the same numerals used in more than one drawing denote the same, similar, or equivalent functionality, components, or blocks.

[0010] **FIG. 1** illustrates the block diagram of an RF transceiver that includes radio circuitry that operates in conjunction with a baseband processor circuitry.

[0011] **FIG. 2A** shows RF transceiver circuitry partitioned according to the invention.

[0012] **FIG. 2B** depicts another embodiment of RF transceiver circuitry partitioned according to the invention, in which the reference generator circuitry resides within the same circuit partition, or circuit block, as does the receiver digital circuitry.

[0013] FIG. 2C illustrates yet another embodiment of RF transceiver circuitry partitioned according to invention, in which the reference generator circuitry resides within the baseband processor circuitry.

[0014] FIG. 2D shows another embodiment of RF transceiver circuitry partitioned according to the invention, in which the receiver digital circuitry resides within the baseband processor circuitry.

[0015] FIG. 3 illustrates interference mechanisms among the various blocks of an RF transceiver, which the embodiments of the invention in FIGS. 2A-2D, depicting RF transceivers partitioned according to the invention, seek to overcome, reduce, or minimize.

[0016] FIG. 4 shows a more detailed block diagram of RF transceiver circuitry partitioned according to the invention.

[0017] FIG. 5 illustrates an alternative technique for partitioning RF transceiver circuitry.

[0018] FIG. 6 shows yet another alternative technique for partitioning RF transceiver circuitry.

[0019] FIG. 7 depicts a more detailed block diagram of RF transceiver circuitry partitioned according to the invention, in which the receiver digital circuitry resides within the baseband processor circuitry.

[0020] FIG. 8 illustrates a more detailed block diagram of a multi-band RF transceiver circuitry partitioned according to the invention.

[0021] FIG. 9A shows a block diagram of an embodiment of the interface between the receiver digital circuitry and receiver analog circuitry in an RF transceiver according to the invention.

[0022] FIG. 9B depicts a block diagram of another embodiment of the interface between the baseband processor circuitry and the receiver analog circuitry in an RF transceiver according to the invention, in which the receiver digital circuitry resides within the baseband processor circuitry.

[0023] FIG. 10 illustrates a more detailed block diagram of the interface between the receiver analog circuitry and the receiver digital circuitry, with the interface configured as a serial interface.

[0024] FIG. 11A shows a more detailed block diagram of an embodiment of the interface between the receiver analog circuitry and the receiver digital circuitry, with the interface configured as a data and clock signal interface.

[0025] FIG. 11B illustrates a block diagram of an embodiment of a delay-cell circuitry that includes a clock driver circuitry in tandem with a clock receiver circuitry.

[0026] FIG. 12 depicts a schematic diagram of an embodiment of a signal-driver circuitry used to interface the receiver analog circuitry and the receiver digital circuitry according to the invention.

[0027] FIGS. 13A and 13B illustrate schematic diagrams of embodiments of signal-receiver circuitries used to interface the receiver analog circuitry and the receiver digital circuitry according to the invention.

[0028] FIG. 14 shows a schematic diagram of another signal-driver circuitry that one may use to interface the receiver analog circuitry and the receiver digital circuitry according to the invention.

[0029] FIG. 15 depicts a portion of a typical spectrum in exemplary embodiments of the invention of the output signal of the receiver analog circuitry that includes the desired signal.

[0030] FIG. 16 illustrates a typical plot of the quantization noise transfer function of the analog-digital converter circuitries in exemplary embodiments of the invention.

[0031] FIG. 17A shows a conceptual or functional block diagram that provides more details of a receiver digital circuitry according to the invention.

[0032] FIG. 17B illustrates a conceptual or functional block diagram that provides more details of a receiver digital circuitry according to the invention that includes programmable-gain amplifier circuitries.

[0033] FIG. 18A depicts a conceptual or functional block diagram that provides more details of an alternative architecture for a receiver digital circuitry according to the invention.

[0034] FIG. 18B shows a conceptual or functional block diagram that provides more details of an alternative architecture for a receiver digital circuitry according to the invention that includes programmable-gain amplifier circuitries.

[0035] FIG. 19 illustrates a conceptual or functional block diagram of an exemplary embodiment of a digital down-converter circuitry for use in receiver digital circuitry according to the invention.

[0036] FIG. 20A shows a conceptual or functional block diagram of an exemplary embodiment of an intermediate-frequency local-oscillator (IF LO) circuitry for use in receiver digital circuitry according to the invention.

[0037] FIG. 20B illustrates a conceptual or functional block diagram of another exemplary embodiment of a combined digital down-converter circuitry and IF LO circuitry for use in receiver digital circuitry according to the invention.

[0038] FIG. 21 depicts a conceptual or functional block diagram of a digital integrator circuitry for use in exemplary embodiments of digital filter circuitry according to the invention.

[0039] FIG. 22 illustrates a conceptual or functional block diagram of a digital differentiator circuitry for use in exemplary embodiments of digital filter circuitry according to the invention.

[0040] FIG. 23 shows a conceptual or functional block diagram of signal flow within a first-order cascaded integrator/comb (CIC) filter circuitry for use in exemplary embodiments of digital filter circuitry according to the invention.

[0041] FIG. 24 depicts a conceptual or functional block diagram of a boxcar filter circuitry for use in exemplary embodiments of digital filter circuitry according to the invention.

[0042] FIG. 25 illustrates a conceptual or functional block diagram of a CIC filter circuitry, which includes decimator circuitry, for use in exemplary embodiments of digital filter circuitry according to the invention.

[0043] FIG. 26 shows a conceptual or functional block diagram of a second-order filter circuitry for use in exemplary embodiments of digital filter circuitry according to the invention.

[0044] FIG. 27 depicts a conceptual or functional block diagram of a notch filter circuitry for use in exemplary embodiments of digital filter circuitry according to the invention.

[0045] FIG. 28A illustrates a conceptual or functional block diagram of a cascade arrangement of a biquad filter circuitry and a notch filter circuitry for use in digital filter circuitry according to the invention.

[0046] FIG. 28B illustrates a conceptual or functional block diagram of a cascade arrangement of a notch filter circuitry and a biquad filter circuitry for use in digital filter circuitry according to the invention.

[0047] FIG. 29A shows a conceptual or functional block diagram of a digital filter circuitry for use in RF apparatus according to the invention, which includes two biquad filter sections and a notch filter section.

[0048] FIG. 29B depicts a conceptual or functional block diagram of a digital filter circuitry for use in RF apparatus according to the invention that includes three biquad filter sections and a notch filter section.

[0049] FIG. 29C illustrates a conceptual or functional block diagram of digital filter circuitry for use in RF apparatus according to the invention that includes five biquad filter sections and a notch filter section.

[0050] FIG. 29D shows a conceptual or functional block diagram of a digital filter circuitry for use in RF apparatus according to the invention, which includes a notch filter section and two biquad filter sections.

[0051] FIG. 29E depicts a conceptual or functional block diagram of a digital filter circuitry for use in RF apparatus according to the invention that includes a notch filter section and three biquad filter sections.

[0052] FIG. 29F illustrates a conceptual or functional block diagram of digital filter circuitry for use in RF apparatus according to the invention that includes a notch filter section and five biquad filter sections.

[0053] FIG. 30A shows a pole-zero diagram on a unit circle for the IIR filter circuitry illustrated in FIG. 29E.

[0054] FIG. 30B depicts plots of magnitude response curves for the IIR filter circuitry illustrated in FIG. 29E.

[0055] FIG. 30C illustrates plots of group delay response curves for the IIR filter circuitry illustrated in FIG. 29E.

[0056] FIG. 31 shows a typical spectrum of the signal at the input of the receiver digital circuitry in exemplary embodiments of the invention.

[0057] FIG. 32 depicts a typical spectrum of the signal at an output of a digital down-converter circuitry in exemplary embodiments of the invention.

[0058] FIG. 33 illustrates a typical spectrum of the signal at an output of a decimator circuitry in exemplary embodiments of the invention.

[0059] FIG. 34 shows a typical spectrum of the signal at an output of a notch-filter circuitry in exemplary embodiments of the invention.

[0060] FIG. 35 depicts a typical spectrum of the signal at an output of the IIR filter circuitry in exemplary embodiments of the invention.

[0061] FIG. 36A illustrates a pole-zero diagram of a double-sided notch-filter circuitry for use in exemplary embodiments of the invention.

[0062] FIG. 36B shows a frequency-domain response spectrum for the double-sided notch-filter circuitry for use in exemplary embodiments of the invention.

[0063] FIG. 37A depicts a pole-zero diagram of a single-sided notch-filter circuitry for use in exemplary embodiments of the invention.

[0064] FIG. 37B illustrates a frequency-domain response spectrum for a single-sided notch-filter circuitry for use in exemplary embodiments of the invention.

[0065] FIG. 38 shows a conceptual or functional block diagram of an alternative notch-filter circuitry for use in exemplary embodiments of the invention.

[0066] FIG. 39 illustrates a typical pole-zero diagram that demonstrates adjustment or gear-shifting of a notch-filter circuitry in exemplary embodiments of the invention.

[0067] FIG. 40 shows a timeline for the operation of various blocks, including the notch filter circuitry, in exemplary embodiments of the invention.

DETAILED DESCRIPTION OF THE INVENTION

[0068] This invention in part contemplates partitioning RF apparatus so as to provide highly integrated, high-performance, low-cost, and low form-factor RF solutions. One may use RF apparatus according to the invention in high-performance communication systems. More particularly, the invention in part relates to partitioning RF receiver or transceiver circuitry in a way that minimizes, reduces, or overcomes interference effects among the various blocks of the RF receiver or transceiver, while simultaneously satisfying the requirements of the standards that govern RF receiver or transceiver performance. Those standards include the Global System for Mobile (GSM) communication, Personal Communication Services (PCS), Digital Cellular System (DCS), Enhanced Data for GSM Evolution (EDGE), and General Packet Radio Services (GPRS). RF receiver or transceiver circuitry partitioned according to the invention therefore overcomes interference effects that would be present in highly integrated RF receivers or transceivers while meeting the requirements of the governing standards at low cost and with a low form-factor. The description of the invention refers to circuit partition and circuit block interchangeably.

[0069] FIG. 1 shows the general block diagram of an RF transceiver circuitry 100 according to the invention. The RF transceiver circuitry 100 includes radio circuitry 110 that couples to an antenna 130 via a bi-directional signal path

160. The radio circuitry **110** provides an RF transmit signal to the antenna **130** via the bi-directional signal path **160** when the transceiver is in transmit mode. When in the receive mode, the radio circuitry **110** receives an RF signal from the antenna **130** via the bi-directional signal path **160**.

[0070] The radio circuitry **110** also couples to a baseband processor circuitry **120**. The baseband processor circuitry **120** may comprise a digital-signal processor (DSP). Alternatively, or in addition to the DSP, the baseband processor circuitry **120** may comprise other types of signal processor, as persons skilled in the art understand. The radio circuitry **110** processes the RF signals received from the antenna **130** and provides receive signals **140** to the baseband processor circuitry **120**. In addition, the radio circuitry **110** accepts transmit input signals **150** from the baseband processor **120** and provides the RF transmit signals to the antenna **130**.

[0071] FIGS. 2A-2D show various embodiments of RF transceiver circuitry partitioned according to the invention. FIG. 3 and its accompanying description below make clear the considerations that lead to the partitioning of the RF transceiver circuitry as shown in FIGS. 2A-2D. FIG. 2A illustrates an embodiment **200A** of an RF transceiver circuitry partitioned according to the invention. In addition to the elements described in connection with FIG. 1, the RF transceiver **200A** includes antenna interface circuitry **202**, receiver circuitry **210**, transmitter circuitry **216**, reference generator circuitry **218**, and local oscillator circuitry **222**.

[0072] The reference generator circuitry **218** produces a reference signal **220** and provides that signal to the local oscillator circuitry **222** and to receiver digital circuitry **212**. The reference signal **220** preferably comprises a clock signal, although it may include other signals, as desired. The local oscillator circuitry **222** produces an RF local oscillator signal **224**, which it provides to receiver analog circuitry **208** and to the transmitter circuitry **216**. The local oscillator circuitry **222** also produces a transmitter intermediate-frequency (IF) local oscillator signal **226** and provides that signal to the transmitter circuitry **216**. Note that, in RF transceivers according to the invention, the receiver analog circuitry **208** generally comprises mostly analog circuitry in addition to some digital or mixed-mode circuitry, for example, analog-to-digital converter (ADC) circuitry and circuitry to provide an interface between the receiver analog circuitry and the receiver digital circuitry, as described below.

[0073] The antenna interface circuitry **202** facilitates communication between the antenna **130** and the rest of the RF transceiver. Although not shown explicitly, the antenna interface circuitry **202** may include a transmit/receive mode switch, RF filters, and other transceiver front-end circuitry, as persons skilled in the art understand. In the receive mode, the antenna interface circuitry **202** provides RF receive signals **204** to the receiver analog circuitry **208**. The receiver analog circuitry **208** uses the RF local oscillator signal **224** to process (e.g., down-convert) the RF receive signals **204** and produce a processed analog signal. The receiver analog circuitry **208** converts the processed analog signal to digital format and supplies the resulting digital receive signals **228** to the receiver digital circuitry **212**. The receiver digital circuitry **212** further processes the digital receive signals **228** and provides the resulting receive signals **140** to the baseband processor circuitry **120**.

[0074] In the transmit mode, the baseband processor circuitry **120** provides transmit input signals **150** to the transmitter circuitry **216**. The transmitter circuitry **216** uses the RF local oscillator signal **224** and the transmitter IF local oscillator signal **226** to process the transmit input signals **150** and to provide the resulting transmit RF signal **206** to the antenna interface circuitry **202**. The antenna interface circuitry **202** may process the transmit RF signal further, as desired, and provide the resulting signal to the antenna **130** for propagation into a transmission medium.

[0075] The embodiment **200A** in FIG. 2A comprises a first circuit partition, or circuit block, **214** that includes the receiver analog circuitry **208** and the transmitter circuitry **216**. The embodiment **200A** also includes a second circuit partition, or circuit block, that includes the receiver digital circuitry **212**. The embodiment **200A** further includes a third circuit partition, or circuit block, that comprises the local oscillator circuitry **222**. The first circuit partition **214**, the second circuit partition **212**, and the third circuit partition **222** are partitioned from one another so that interference effects among the circuit partitions tend to be reduced. The first, second, and third circuit partitions preferably each reside within an integrated circuit device. In other words, preferably the receiver analog circuitry **208** and the transmitter circuitry **216** reside within an integrated circuit device, the receiver digital circuitry **212** resides within another integrated circuit device, and the local oscillator circuitry **222** resides within a third integrated circuit device.

[0076] FIG. 2B shows an embodiment **200B** of an RF transceiver circuitry partitioned according to the invention. The embodiment **200B** has the same circuit topology as that of embodiment **200A** in FIG. 2A. The partitioning of embodiment **200B**, however, differs from the partitioning of embodiment **200A**. Like embodiment **200A**, embodiment **200B** has three circuit partitions, or circuit blocks. The first and the third circuit partitions in embodiment **200B** are similar to the first and third circuit partitions in embodiment **200A**. The second circuit partition **230** in embodiment **200B**, however, includes the reference signal generator **218** in addition to the receiver digital circuitry **212**. As in embodiment **200A**, embodiment **200B** is partitioned so that interference effects among the three circuit partitions tend to be reduced.

[0077] FIG. 2C illustrates an embodiment **200C**, which constitutes a variation of embodiment **200A** in FIG. 2A. Embodiment **200C** shows that one may place the reference signal generator **218** within the baseband processor circuitry **120**, as desired. Placing the reference signal generator **218** within the baseband processor circuitry **120** obviates the need for either discrete reference signal generator circuitry **218** or an additional integrated circuit or module that includes the reference signal generator **218**. Embodiment **200C** has the same partitioning as embodiment **200A**, and operates in a similar manner.

[0078] Note that FIGS. 2A-2C show the receiver circuitry **210** as a block to facilitate the description of the embodiments shown in those figures. In other words, the block containing the receiver circuitry **210** in FIGS. 2A-2C constitutes a conceptual depiction of the receiver circuitry within the RF transceiver shown in FIGS. 2A-2C, not a circuit partition or circuit block.

[0079] FIG. 2D shows an embodiment **200D** of an RF transceiver partitioned according to the invention. The RF

transceiver in **FIG. 2D** operates similarly to the transceiver shown in **FIG. 2A**. The embodiment **200D**, however, accomplishes additional economy by including the receiver digital circuitry **212** within the baseband processor circuitry **120**. As one alternative, one may integrate the entire receiver digital circuitry **212** on the same integrated circuit device that includes the baseband processor circuitry **120**. Note that one may use software (or firmware), hardware, or a combination of software (or firmware) and hardware to realize the functions of the receiver digital circuitry **212** within the baseband processor circuitry **120**, as persons skilled in the art who have the benefit of the description of the invention understand. Note also that, similar to the embodiment **200C** in **FIG. 2C**, the baseband processor circuitry **120** in embodiment **200D** may also include the reference signal generator **218**, as desired.

[0080] The partitioning of embodiment **200D** involves two circuit partitions, or circuit blocks. The first circuit partition **214** includes the receiver analog circuitry **208** and the transmitter circuitry **216**. The second circuit partition includes the local oscillator circuitry **222**. The first and second circuit partitions are partitioned so that interference effects between them tend to be reduced.

[0081] **FIG. 3** shows the mechanisms that may lead to interference among the various blocks or components in a typical RF transceiver, for example, the transceiver shown in **FIG. 2A**. Note that the paths with arrows in **FIG. 3** represent interference mechanisms among the blocks within the transceiver, rather than desired signal paths. One interference mechanism results from the reference signal **220** (see **FIGS. 2A-2D**), which preferably comprises a clock signal. In the preferred embodiments, the reference generator circuitry produces a clock signal that may have a frequency of 13 MHz (GSM clock frequency) or 26 MHz. If the reference generator produces a 26 MHz clock signal, RF transceivers according to the invention preferably divide that signal by two to produce a 13 MHz master system clock. The clock signal typically includes voltage pulses that have many Fourier series harmonics. The Fourier series harmonics extend to many multiples of the clock signal frequency. Those harmonics may interfere with the receiver analog circuitry **208** (e.g., the low-noise amplifier, or LNA), the local oscillator circuitry **222** (e.g., the synthesizer circuitry), and the transmitter circuitry **216** (e.g., the transmitter's voltage-controlled oscillator, or VCO). **FIG. 3** shows these sources of interference as interference mechanisms **360**, **350**, and **340**.

[0082] The receiver digital circuitry **212** uses the output of the reference generator circuitry **218**, which preferably comprises a clock signal. Interference mechanism **310** exists because of the sensitivity of the receiver analog circuitry **208** to the digital switching noise and harmonics present in the receiver digital circuitry **212**. Interference mechanism **310** may also exist because of the digital signals (for example, clock signals) that the receiver digital circuitry **212** communicates to the receiver analog circuitry **208**. Similarly, the digital switching noise and harmonics in the receiver digital circuitry **212** may interfere with the local oscillator circuitry **222**, giving rise to interference mechanism **320** in **FIG. 3**.

[0083] The local oscillator circuitry **222** typically uses an inductor in an inductive-capacitive (LC) resonance tank (not shown explicitly in the figures). The resonance tank may

circulate relatively large currents. Those currents may couple to the sensitive circuitry within the transmitter circuitry **216** (e.g., the transmitter's VCO), thus giving rise to interference mechanism **330**. Similarly, the relatively large currents circulating within the resonance tank of the local oscillator circuitry **222** may saturate sensitive components within the receiver analog circuitry **208** (e.g., the LNA circuitry). **FIG. 3** depicts this interference source as interference mechanism **370**.

[0084] The timing of the transmit mode and receive mode in the GSM specifications help to mitigate potential interference between the transceiver's receive-path circuitry and its transmit-path circuitry. The GSM specifications use time-division duplexing (TDD). According to the TDD protocol, the transceiver deactivates the transmit-path circuitry while in the receive mode of operation, and vice-versa. Consequently, **FIG. 3** does not show potential interference mechanisms between the transmitter circuitry **216** and either the receiver digital circuitry **212** or the receiver analog circuitry **208**.

[0085] As **FIG. 3** illustrates, interference mechanisms exist between the local oscillator circuitry **222** and each of the other blocks or components in the RF transceiver. Thus, to reduce interference effects, RF transceivers according to the invention preferably partition the local oscillator circuitry **222** separately from the other transceiver blocks shown in **FIG. 3**. Note, however, that in some circumstances one may include parts or all of the local oscillator circuitry within the same circuit partition (for example, circuit partition **214** in **FIGS. 2A-2D**) that includes the receiver analog circuitry and the transmitter circuitry, as desired. Typically, a voltage-controlled oscillator (VCO) within the local oscillator circuitry causes interference with other sensitive circuit blocks (for example, the receiver analog circuitry) through undesired coupling mechanisms. If those coupling mechanisms can be mitigated to the extent that the performance characteristics of the RF transceiver are acceptable in a given application, then one may include the local oscillator circuitry within the same circuit partition as the receiver analog circuitry and the transmitter circuitry. Alternatively, if the VCO circuitry causes unacceptable levels of interference, one may include other parts of the local oscillator circuitry within the circuit partition that includes the receiver analog circuitry and the transmitter circuitry, but exclude the VCO circuitry from that circuit partition.

[0086] To reduce the effects of interference mechanism **310**, RF transceivers according to the invention partition the receiver analog circuitry **208** separately from the receiver digital circuitry **212**. Because of the mutually exclusive operation of the transmitter circuitry **216** and the receiver analog circuitry **208** according to GSM specifications, the transmitter circuitry **216** and the receiver analog circuitry **208** may reside within the same circuit partition, or circuit block. Placing the transmitter circuitry **216** and the receiver analog circuitry **208** within the same circuit partition results in a more integrated RF transceiver overall. The RF transceivers shown in **FIGS. 2A-2D** employ partitioning techniques that take advantage of the above analysis of the interference mechanisms among the various transceiver components. To reduce interference effects among the various circuit partitions or circuit blocks even further, RF

transceivers according to the invention also use differential signals to couple the circuit partitions or circuit blocks to one another.

[0087] FIG. 4 shows a more detailed block diagram of an embodiment 400 of an RF transceiver partitioned according to the invention. The transceiver includes receiver analog circuitry 408, receiver digital circuitry 426, and transmitter circuitry 465. In the receive mode, the antenna interface circuitry 202 provides an RF signal 401 to a filter circuitry 403. The filter circuitry 403 provides a filtered RF signal 406 to the receiver analog circuitry 408. The receiver analog circuitry 408 includes down-converter (i.e., mixer) circuitry 409 and analog-to-digital converter (ADC) circuitry 418. The down-converter circuitry 409 mixes the filtered RF signal 406 with an RF local oscillator signal 454, received from the local oscillator circuitry 222. The down-converter circuitry 409 provides an in-phase analog down-converted signal 412 (i.e., I-channel signal) and a quadrature analog down-converted signal 415 (i.e., Q-channel signal) to the ADC circuitry 418.

[0088] The ADC circuitry 418 converts the in-phase analog down-converted signal 412 and the quadrature analog down-converted signal 415 into a one-bit in-phase digital receive signal 421 and a one-bit quadrature digital receive signal 424. (Note that FIGS. 4-8 illustrate signal flow, rather than specific circuit implementations; for more details of the circuit implementation, for example, more details of the circuitry relating to the one-bit in-phase digital receive signal 421 and the one-bit quadrature digital receive signal 424, see FIGS. 9-14.) Thus, The ADC circuitry 418 provides the one-bit in-phase digital receive signal 421 and the one-bit quadrature digital receive signal 424 to the receiver digital circuitry 426. As described below, rather than, or in addition to, providing the one-bit in-phase and quadrature digital receive signals to the receiver digital circuitry 426, the digital interface between the receiver analog circuitry 408 and the receiver digital circuitry 426 may communicate various other signals. By way of illustration, those signals may include reference signals (e.g., clock signals), control signals, logic signals, hand-shaking signals, data signals, status signals, information signals, flag signals, and/or configuration signals. Moreover, the signals may constitute single-ended or differential signals, as desired. Thus, the interface provides a flexible communication mechanism between the receiver analog circuitry and the receiver digital circuitry.

[0089] The receiver digital circuitry 426 includes digital down-converter circuitry 427, digital filter circuitry 436, and digital-to-analog converter (DAC) circuitry 445. The digital down-converter circuitry 427 accepts the one-bit in-phase digital receive signal 421 and the one-bit quadrature digital receive signal 424 from the receiver analog circuitry 408. The digital down-converter circuitry 427 converts the received signals into a down-converted in-phase signal 430 and a down-converted quadrature signal 433 and provides those signals to the digital filter circuitry 436. The digital filter circuitry 436 preferably comprises an infinite impulse response (IIR) channel-select filter that performs various filtering operations on its input signals. The digital filter circuitry 436 preferably has programmable response characteristics. Note that, rather than using an IIR filter, one may

use other types of filter (e.g., finite impulse-response, or FIR, filters) that provide fixed or programmable response characteristics, as desired.

[0090] The digital filter circuitry 436 provides a digital in-phase filtered signal 439 and a digital quadrature filtered signal 442 to the DAC circuitry 445. The DAC circuitry 445 converts the digital in-phase filtered signal 439 and the digital quadrature filtered signal 442 to an in-phase analog receive signal 448 and a quadrature analog receive signal 451, respectively. The baseband processor circuitry 120 accepts the in-phase analog receive signal 448 and the quadrature analog receive signal 451 for further processing.

[0091] The transmitter circuitry 465 comprises baseband up-converter circuitry 466, offset phase-lock-loop (PLL) circuitry 472, and transmit voltage-controlled oscillator (VCO) circuitry 481. The transmit VCO circuitry 481 typically has low-noise circuitry and is sensitive to external noise. For example, it may pick up interference from digital switching because of the high gain that results from the resonant LC-tank circuit within the transmit VCO circuitry 481. The baseband up-converter circuitry 466 accepts an intermediate frequency (IF) local oscillator signal 457 from the local oscillator circuitry 222. The baseband up-converter circuitry 466 mixes the IF local oscillator signal 457 with an analog in-phase transmit input signal 460 and an analog quadrature transmit input signal 463 and provides an up-converted IF signal 469 to the offset PLL circuitry 472.

[0092] The offset PLL circuitry 472 effectively filters the IF signal 469. In other words, the offset PLL circuitry 472 passes through it signals within its bandwidth but attenuates other signals. In this manner, the offset PLL circuitry 472 attenuates any spurious or noise signals outside its bandwidth, thus reducing the requirement for filtering at the antenna 130, and reducing system cost, insertion loss, and power consumption. The offset PLL circuitry 472 forms a feedback loop with the transmit VCO circuitry 481 via an offset PLL output signal 475 and a transmit VCO output signal 478. The transmit VCO circuitry 481 preferably has a constant-amplitude output signal.

[0093] The offset PLL circuitry 472 uses a mixer (not shown explicitly in FIG. 4) to mix the RF local oscillator signal 454 with the transmit VCO output signal 478. Power amplifier circuitry 487 accepts the transmit VCO output signal 478, and provides an amplified RF signal 490 to the antenna interface circuitry 202. The antenna interface circuitry 202 and the antenna 130 operate as described above. RF transceivers according to the invention preferably use transmitter circuitry 465 that comprises analog circuitry, as shown in FIG. 4. Using such circuitry minimizes interference with the transmit VCO circuitry 481 and helps to meet emission specifications for the transmitter circuitry 465.

[0094] The receiver digital circuitry 426 also accepts the reference signal 220 from the reference generator circuitry 218. The reference signal 220 preferably comprises a clock signal. The receiver digital circuitry 426 provides to the transmitter circuitry 465 a switched reference signal 494 by using a switch 492. Thus, the switch 492 may selectively provide the reference signal 220 to the transmitter circuitry 465. Before the RF transceiver enters its transmit mode, the receiver digital circuitry 426 causes the switch 492 to close, thus providing the switched reference signal 494 to the transmitter circuitry 465.

[0095] The transmitter circuitry 465 uses the switched reference signal 494 to calibrate or adjust some of its components. For example, the transmitter circuitry 465 may use the switched reference signal 494 to calibrate some of its components, such as the transmit VCO circuitry 481, for example, as described in commonly owned U.S. Pat. No. 6,137,372, incorporated by reference here in its entirety. The transmitter circuitry 465 may also use the switched reference signal 494 to adjust a voltage regulator within its output circuitry so as to transmit at known levels of RF radiation or power.

[0096] While the transmitter circuitry 465 calibrates and adjusts its components, the analog circuitry within the transmitter circuitry 465 powers up and begins to settle. When the transmitter circuitry 465 has finished calibrating its internal circuitry, the receiver digital circuitry 426 causes the switch 492 to open, thus inhibiting the supply of the reference signal 220 to the transmitter circuitry 465. At this point, the transmitter circuitry may power up the power amplifier circuitry 487 within the transmitter circuitry 465. The RF transceiver subsequently enters the transmit mode of operation and proceeds to transmit.

[0097] Note that FIG. 4 depicts the switch 492 as a simple switch for conceptual, schematic purposes. One may use a variety of devices to realize the function of the controlled switch 492, for example, semiconductor switches, gates, or the like, as persons skilled in the art who have the benefit of the disclosure of the invention understand. Note also that, although FIG. 4 shows the switch 492 as residing within the receiver digital circuitry 426, one may locate the switch in other locations, as desired. Placing the switch 492 within the receiver digital circuitry 426 helps to confine to the receiver digital circuitry 426 the harmonics that result from the switching circuitry.

[0098] The embodiment 400 in FIG. 4 comprises a first circuit partition 407, or circuit block, that includes the receiver analog circuitry 408 and the transmitter circuitry 465. The embodiment 400 also includes a second circuit partition, or circuit block, that includes the receiver digital circuitry 426. Finally, the embodiment 400 includes a third circuit partition, or circuit block, that comprises the local oscillator circuitry 222. The first circuit partition 407, the second circuit partition, and the third circuit partition are partitioned from one another so that interference effects among the circuit partitions tend to be reduced. That arrangement tends to reduce the interference effects among the circuit partitions by relying on the analysis of interference effects provided above in connection with FIG. 3. Preferably, the first, second, and third circuit partitions each reside within an integrated circuit device. To further reduce interference effects among the circuit partitions, the embodiment 400 in FIG. 4 uses differential signals wherever possible. The notation “(diff.)” adjacent to signal lines or reference numerals in FIG. 4 denotes the use of differential lines to propagate the annotated signals.

[0099] Note that the embodiment 400 shown in FIG. 4 uses an analog-digital-analog signal path in its receiver section. In other words, the ADC circuitry 418 converts analog signals into digital signals for further processing, and later conversion back into analog signals by the DAC circuitry 445. RF transceivers according to the invention use this particular signal path for the following reasons. First,

the ADC circuitry 418 obviates the need for propagating signals from the receiver analog circuitry 408 to the receiver digital circuitry 426 over an analog interface with a relatively high dynamic range. The digital interface comprising the one-bit in-phase digital receive signal 421 and the one-bit quadrature digital receive signal 424 is less susceptible to the effects of noise and interference than would be an analog interface with a relatively high dynamic range.

[0100] Second, the RF transceiver in FIG. 4 uses the DAC circuitry 445 to maintain compatibility with interfaces commonly used to communicate with baseband processor circuitry in RF transceivers. According to those interfaces, the baseband processor accepts analog, rather than digital, signals from the receive path circuitry within the RF transceiver. In an RF transceiver that meets the specifications of those interfaces, the receiver digital circuitry 426 would provide analog signals to the baseband processor circuitry 120. The receiver digital circuitry 426 uses the DAC circuitry 445 to provide analog signals (i.e., the in-phase analog receive signal 448 and the quadrature analog receive signal 451) to the baseband processor circuitry 120. The DAC circuitry 445 allows programming the common-mode level and the full-scale voltage, which may vary among different baseband processor circuitries.

[0101] Third, compared to an analog solution, the analog-digital-analog signal path may result in reduced circuit size and area (for example, the area occupied within an integrated circuit device), thus lower cost. Fourth, the digital circuitry provides better repeatability, relative ease of testing, and more robust operation than its analog counterpart. Fifth, the digital circuitry has less dependence on supply voltage variation, temperature changes, and the like, than does comparable analog circuitry.

[0102] Sixth, the baseband processor circuitry 120 typically includes programmable digital circuitry, and may subsume the functionality of the digital circuitry within the receiver digital circuitry 426, if desired. Seventh, the digital circuitry allows more precise signal processing, for example, filtering, of signals within the receive path. Eighth, the digital circuitry allows more power-efficient signal processing. Finally, the digital circuitry allows the use of readily programmable DAC circuitry and PGA circuitry that provide for more flexible processing of the signals within the receive path. To benefit from the analog-digital-analog signal path, RF transceivers according to the invention use a low-IF signal (for example, 100 KHz for GSM applications) in their receive path circuitry, as using higher IF frequencies may lead to higher performance demands on the ADC and DAC circuitry within that path. The low-IF architecture also eases image-rejection requirements, and allows on-chip integration of the digital filter circuitry 436. Moreover, RF transceivers according to the invention use the digital down-converter circuitry 427 and the digital filter circuitry 436 to implement a digital-IF path in the receive signal path. The digital-IF architecture facilitates the implementation of the digital interface between the receiver digital circuitry 426 and the receiver analog circuitry 408.

[0103] If the receiver digital circuitry 426 need not be compatible with the common analog interface to baseband processors, one may remove the DAC circuitry 445 and use a digital interface to the baseband processor circuitry 120, as desired. In fact, similar to the RF transceiver shown in FIG.

2D, one may realize the function of the receiver digital circuitry 426 within the baseband processor circuitry 120, using hardware, software, or a combination of hardware and software. In that case, the RF transceiver would include two circuit partitions, or circuit blocks. The first circuit partition, or circuit block, 407 would include the receiver analog circuitry 408 and the transmitter circuitry 465. A second circuit partition, or circuit block, would comprise the local oscillator circuitry 222. Note also that, similar to the RF transceiver shown in FIG. 2C, one may include within the baseband processor circuitry 120 the functionality of the reference generator circuitry 218, as desired.

[0104] One may partition the RF transceiver shown in FIG. 4 in other ways. FIGS. 5 and 6 illustrate alternative partitioning of the RF transceiver of FIG. 4. FIG. 5 shows an embodiment 500 of an RF transceiver that includes three circuit partitions, or circuit blocks. A first circuit partition includes the receiver analog circuitry 408. A second circuit partition 505 includes the receiver digital circuitry 426 and the transmitter circuitry 465. As noted above, the GSM specifications provide for alternate operation of RF transceivers in receive and transmit modes. The partitioning shown in FIG. 5 takes advantage of the GSM specifications by including the receiver digital circuitry 426 and the transmitter circuitry 465 within the second circuit partition 505. A third circuit partition includes the local oscillator circuitry 222. Preferably, the first, second, and third circuit partitions each reside within an integrated circuit device. Similar to embodiment 400 in FIG. 4, the embodiment 500 in FIG. 5 uses differential signals wherever possible to further reduce interference effects among the circuit partitions.

[0105] FIG. 6 shows another alternative partitioning of an RF transceiver. FIG. 6 shows an embodiment 600 of an RF transceiver that includes three circuit partitions, or circuit blocks. A first circuit partition 610 includes part of the receiver analog circuitry, i.e., the down-converter circuitry 409, together with the transmitter circuitry 465. A second circuit partition 620 includes the ADC circuitry 418, together with the receiver digital circuitry, i.e., the digital down-converter circuitry 427, the digital filter circuitry 436, and the DAC circuitry 445. A third circuit partition includes the local oscillator circuitry 222. Preferably, the first, second, and third circuit partitions each reside within an integrated circuit device. Similar to embodiment 400 in FIG. 4, the embodiment 600 in FIG. 6 uses differential signals wherever possible to further reduce interference effects among the circuit partitions.

[0106] FIG. 7 shows a variation of the RF transceiver shown in FIG. 4. FIG. 7 illustrates an embodiment 700 of an RF transceiver partitioned according to the invention. Note that, for the sake of clarity, FIG. 7 does not explicitly show the details of the receiver analog circuitry 408, the transmitter circuitry 465, and the receiver digital circuitry 426. The receiver analog circuitry 408, the transmitter circuitry 465, and the receiver digital circuitry 426 include circuitry similar to those shown in their corresponding counterparts in FIG. 4. Similar to the RF transceiver shown in FIG. 2D, the embodiment 700 in FIG. 7 shows an RF transceiver in which the baseband processor 120 includes the function of the receiver digital circuitry 426. The baseband processor circuitry 120 may realize the function of the

receiver digital circuitry 426 using hardware, software, or a combination of hardware and software.

[0107] Because the embodiment 700 includes the function of the receiver digital circuitry 426 within the baseband processor circuitry 120, it includes two circuit partitions, or circuit blocks. A first circuit partition 710 includes the receiver analog circuitry 408 and the transmitter circuitry 465. A second circuit partition comprises the local oscillator circuitry 222. Note also that, similar to the RF transceiver shown in FIG. 2C, one may also include within the baseband processor circuitry 120 the functionality of the reference generator circuitry 218, as desired.

[0108] FIG. 8 shows an embodiment 800 of a multi-band RF transceiver, partitioned according to the invention. Preferably, the RF transceiver in FIG. 8 operates within the GSM (925 to 960 MHz for reception and 880-915 MHz for transmission), PCS (1930 to 1990 MHz for reception and 1850-1910 MHz for transmission), and DCS (1805 to 1880 MHz for reception and 1710-1785 MHz for transmission) bands. Like the RF transceiver in FIG. 4, the RF transceiver in FIG. 8 uses a low-IF architecture. The embodiment 800 includes receiver analog circuitry 839, receiver digital circuitry 851, transmitter circuitry 877, local oscillator circuitry 222, and reference generator circuitry 218. The local oscillator circuitry 222 includes RF phase-lock loop (PLL) circuitry 840 and intermediate-frequency (IF) PLL circuitry 843. The RF PLL circuitry 840 produces the RF local oscillator, or RF LO, signal 454, whereas the IF PLL circuitry 843 produces the IF local oscillator, or IF LO, signal 457.

[0109] Table 1 below shows the preferred frequencies for the RF local oscillator signal 454 during the receive mode:

TABLE 1

Band	RF Local Oscillator Frequency (MHz)
GSM	1849.8-1919.8
DCS	1804.9-1879.9
PCS	1929.9-1989.9
All Bands	1804.9-1989.9

[0110] Table 2 below lists the preferred frequencies for the RF local oscillator signal 454 during the transmit mode:

TABLE 2

Band	RF Local Oscillator Frequency (MHz)
GSM	1279-1314
DCS	1327-1402
PCS	1423-1483
All Bands	1279-1483

[0111] During the receive mode, the IF local oscillator signal 457 is preferably turned off. In preferred embodiments, during the transmit mode, the IF local oscillator signal 457 preferably has a frequency between 383 MHz and 427 MHz. Note, however, that one may use other frequencies for the RF and IF local oscillator signals 454 and 457, as desired.

[0112] The reference generator 218 provides a reference signal 220 that preferably comprises a clock signal, although

one may use other signals, as persons skilled in the art who have the benefit of the description of the invention understand. Moreover, the transmitter circuitry **877** preferably uses high-side injection for the GSM band and low-side injection for the DCS and PCS bands.

[0113] The receive path circuitry operates as follows. Filter circuitry **812** accepts a GSM RF signal **803**, a DCS RF signal **806**, and a PCS RF signal **809** from the antenna interface circuitry **202**. The filter circuitry **812** preferably contains a surface-acoustic-wave (SAW) filter for each of the three bands, although one may use other types and numbers of filters, as desired. The filter circuitry **812** provides a filtered GSM RF signal **815**, a filtered DCS RF signal **818**, and a filtered PCS RF signal **821** to low-noise amplifier (LNA) circuitry **824**. The LNA circuitry **824** preferably has programmable gain, and in part provides for programmable gain in the receive path circuitry.

[0114] The LNA circuitry **824** provides an amplified RF signal **827** to down-converter circuitry **409**. In exemplary embodiments according to the invention, amplified RF signal **827** includes multiple signal lines, which may be differential signal lines, to accommodate the GSM, DCS, and PCS bands. Note that, rather than using the LNA circuitry with a real output, one may use an LNA circuitry that has complex outputs (in-phase and quadrature outputs), together with a poly-phase filter circuitry. The combination of the complex LNA circuitry and the poly-phase filter circuitry provides better image rejection, albeit with a somewhat higher loss. Thus, the choice of using the complex LNA circuitry and the poly-phase filter circuitry depends on a trade-off between image rejection and loss in the poly-phase filter circuitry.

[0115] The down-converter circuitry **409** mixes the amplified RF signal **827** with the RF local oscillator signal **454**, which it receives from the RF PLL circuitry **840**. The down-converter circuitry **409** produces the in-phase analog down-converted signal **412** and the quadrature in-phase analog down-converted signal **415**. The down-converter circuitry **409** provides the in-phase analog down-converted signal **412** and the quadrature in-phase analog down-converted signal **415** to a pair of programmable-gain amplifiers (PGAs) **833A** and **833B**.

[0116] The PGA **833A** and PGA **833B** in part allow for programming the gain of the receive path. The PGA **833A** and the PGA **833B** supply an analog in-phase amplified signal **841** and an analog quadrature amplified signal **842** to complex ADC circuitry **836** (i.e., both I and Q inputs will affect both I and Q outputs). The ADC circuitry **836** converts the analog in-phase amplified signal **841** into a one-bit in-phase digital receive signal **421**. Likewise, the ADC circuitry **836** converts the analog quadrature amplified signal **842** into a one-bit quadrature digital receive signal **424**.

[0117] Note that RF transceivers and receivers according to the invention preferably use a one-bit digital interface. One may, however, use a variety of other interfaces, as persons skilled in the art who have the benefit of the description of the invention understand. For example, one may use a multi-bit interface or a parallel interface. Moreover, as described below, rather than, or in addition to, providing the one-bit in-phase and quadrature digital receive signals to the receiver digital circuitry **851**, the digital interface between the receiver analog circuitry **839** and the

receiver digital circuitry **851** may communicate various other signals. By way of illustration, those signals may include reference signals (e.g., clock signals), control signals, logic signals, hand-shaking signals, data signals, status signals, information signals, flag signals, and/or configuration signals. Furthermore, the signals may constitute single-ended or differential signals, as desired. Thus, the interface provides a flexible communication mechanism between the receiver analog circuitry and the receiver digital circuitry.

[0118] The receiver digital circuitry **851** accepts the one-bit in-phase digital receive signal **421** and the one-bit quadrature digital receive signal **424**, and provides them to the digital down-converter circuitry **427**. The digital down-converter circuitry **427** converts the received signals into a down-converted in-phase signal **430** and a down-converted quadrature signal **433** and provides those signals to the digital filter circuitry **436**. The digital filter circuitry **436** preferably comprises an IIR channel-select filter that performs filtering operations on its input signals. Note, however, that one may use other types of filters, for example, FIR filters, as desired.

[0119] The digital filter circuitry **436** provides the digital in-phase filtered signal **439** to a digital PGA **863A** and the digital quadrature filtered signal **442** to a digital PGA **863B**. The digital PGA **863A** and PGA **863B** in part allow for programming the gain of the receive path circuitry. The digital PGA **863A** supplies an amplified digital in-phase signal **869** to DAC circuitry **875A**, whereas the digital PGA **863B** supplies an amplified digital quadrature signal **872** to DAC circuitry **875B**. The DAC circuitry **875A** converts the amplified digital in-phase signal **869** to the in-phase analog receive signal **448**. The DAC circuitry **875B** converts the amplified digital quadrature signal **872** signal into the quadrature analog receive signal **451**. The baseband processor circuitry **120** accepts the in-phase analog receive signal **448** and the quadrature analog receive signal **451** for further processing, as desired.

[0120] Note that the digital circuit blocks shown in the receiver digital circuitry **851** depict mainly the conceptual functions and signal flow. The actual digital-circuit implementation may or may not contain separately identifiable hardware for the various functional blocks. For example, one may re-use (in time, for instance, by using multiplexing) the same digital circuitry to implement both digital PGA **863A** and digital PGA **863B**, as desired.

[0121] Note also that, similar to the RF transceiver in FIG. 4, the RF transceiver in FIG. 8 features a digital-IF architecture. The digital-IF architecture facilitates the implementation of the one-bit digital interface between the receiver digital circuitry **426** and the receiver analog circuitry **408**. Moreover, the digital-IF architecture allows digital (rather than analog) IF-filtering, thus providing all of the advantages of digital filtering.

[0122] The transmitter circuitry **877** comprises baseband up-converter circuitry **466**, transmit VCO circuitry **481**, a pair of transmitter output buffers **892A** and **892B**, and offset PLL circuitry **897**. The offset PLL circuitry **897** includes offset mixer circuitry **891**, phase detector circuitry **882**, and loop filter circuitry **886**. The baseband up-converter circuitry **466** accepts the analog in-phase transmit input signal **460** and the analog quadrature transmit input signal **463**, mixes those signals with the IF local oscillator signal **457**, and

provides a transmit IF signal **880** to the offset PLL circuitry **897**. The offset PLL circuitry **897** uses the transmit IF signal **880** as a reference signal. The transmit IF signal **880** preferably comprises a modulated single-sideband IF signal but, as persons skilled in the art who have the benefit of the description of the invention understand, one may use other types of signal and modulation, as desired.

[0123] The offset mixer circuitry **891** in the offset PLL circuitry **897** mixes the transmit VCO output signal **478** with the RF local oscillator signal **454**, and provides a mixed signal **890** to the phase detector circuitry **882**. The phase detector circuitry **882** compares the mixed signal **890** to the transmit IF signal **880** and provides an offset PLL error signal **884** to the loop filter circuitry **886**. The loop filter circuitry **886** in turn provides a filtered offset PLL signal **888** to the transmit VCO circuitry **481**. Thus, the offset PLL circuitry **897** and the transmit VCO circuitry **481** operate in a feedback loop. Preferably, the output frequency of the transmit VCO circuitry **481** centers between the DCS and PCS bands, and its output is divided by two for the GSM band.

[0124] Transmitter output buffers **892A** and **892B** receive the transmit VCO output signal **478** and provide buffered transmit signals **894** and **895** to a pair of power amplifiers **896A** and **896B**. The power amplifiers **896A** and **896B** provide amplified RF signals **899** and **898**, respectively, for transmission through antenna interface circuitry **202** and the antenna **130**. Power amplifier **896A** provides the RF signal **899** for the GSM band, whereas power amplifier **896B** supplies the RF signal **898** for the DCS and PCS bands. Persons skilled in the art who have the benefit of the description of the invention, however, understand that one may use other arrangements of power amplifiers and frequency bands. Moreover, one may use RF filter circuitry within the output path of the transmitter circuitry **877**, as desired.

[0125] The embodiment **800** comprises three circuit partitions, or circuit blocks. A first circuit partition **801** includes the receiver analog circuitry **839** and the transmitter circuitry **877**. A second circuit partition **854** includes the receiver digital circuitry **851** and the reference generator circuitry **218**. Finally, a third circuit partition comprises the local oscillator circuitry **222**. The first circuit partition **801**, the second circuit partition **854**, and the third circuit partition are partitioned from one another so that interference effects among the circuit partitions tend to be reduced. That arrangement tends to reduce the interference effects among the circuit partitions because of the analysis of interference effects provided above in connection with **FIG. 3**. Preferably, the first, second, and third circuit partitions each reside within an integrated circuit device. To further reduce interference effects among the circuit partitions, the embodiment **800** in **FIG. 8** uses differential signals wherever possible. The notation "(diff.)" adjacent to signal lines or reference numerals in **FIG. 8** denotes the use of differential lines to propagate the annotated signals.

[0126] Note that, similar to the RF transceiver shown in **FIG. 4** and described above, the embodiment **800** shown in **FIG. 8** uses an analog-digital-analog signal path in its receiver section. The embodiment **800** uses this particular signal path for reasons similar to those described above in connection with the transceiver shown in **FIG. 4**.

[0127] Like the transceiver in **FIG. 4**, if the receiver digital circuitry **851** need not be compatible with the common analog interface to baseband processors, one may remove the DAC circuitry **875A** and **875B**, and use a digital interface to the baseband processor circuitry **120**, as desired. In fact, similar to the RF transceiver shown in **FIG. 2D**, one may realize the function of the receiver digital circuitry **851** within the baseband processor circuitry **120**, using hardware, software, or a combination of hardware and software. In that case, the RF transceiver would include two circuit partitions, or circuit blocks. The first circuit partition **801** would include the receiver analog circuitry **839** and the transmitter circuitry **877**. A second circuit partition would comprise the local oscillator circuitry **222**. Note also that, similar to the RF transceiver shown in **FIG. 2C**, in the embodiment **800**, one may include within the baseband processor circuitry **120** the functionality of the reference generator circuitry **218**, as desired.

[0128] Another aspect of the invention includes a configurable interface between the receiver digital circuitry and the receiver analog circuitry. Generally, one would seek to minimize digital switching activity within the receiver analog circuitry. Digital switching activity within the receiver analog circuitry would potentially interfere with the sensitive analog RF circuitry, for example, LNAs, or mixers. As described above, the receiver analog circuitry includes analog-to-digital circuitry (ADC), which preferably comprises sigma-delta-type ADCs. Sigma-delta ADCs typically use a clock signal at their output stages that generally has a pulse shape and, thus, contains high-frequency Fourier series harmonics. Moreover, the ADC circuitry itself produces digital outputs that the receiver digital circuitry uses. The digital switching present at the outputs of the ADC circuitry may also interfere with sensitive analog circuitry within the receiver analog circuitry.

[0129] The invention contemplates providing RF apparatus according to the invention, for example, receivers and transceivers, that include an interface circuitry to minimize or reduce the effects of interference from digital circuitry within the RF apparatus. **FIG. 9A** shows an embodiment **900A** of an interface between the receiver digital circuitry **905** and the receiver analog circuitry **910**. The interface includes configurable interface signal lines **945**. The baseband processor circuitry **120** in the transceiver of **FIG. 9A** communicates configuration, status, and setup information with both the receiver digital circuitry **905** and the receiver analog circuitry **910**. In the preferred embodiments of RF transceivers according to the invention, the baseband processor circuitry **120** communicates with the receiver digital circuitry **905** and the receiver analog circuitry **910** by sending configuration data to read and write registers included within the receiver digital circuitry **905** and the receiver analog circuitry **910**.

[0130] The receiver digital circuitry **905** communicates with the baseband processor circuitry **120** through a set of serial interface signal lines **920**. The serial interface signal lines **920** preferably include a serial data-in (SDI) signal line **925**, a serial clock (SCLK) signal line **930**, a serial interface enable (SENB) signal line **935**, and a serial data-out (SDO) signal line **940**. The transceiver circuitry and the baseband processor circuitry **120** preferably hold all of the serial interface signal lines **920** at static levels during the transmit and receive modes of operation. The serial interface prefer-

ably uses a 22-bit serial control word that comprises 6 address bits and 16 data bits. Note, however, that one may use other serial interfaces, parallel interfaces, or other types of interfaces, that incorporate different numbers of signal lines, different types and sizes of signals, or both, as desired. Note also that, the SENB signal is preferably an active-low logic signal, although one may use a normal (i.e., an active-high) logic signal by making circuit modifications, as persons skilled in the art understand.

[0131] The receiver digital circuitry 905 communicates with the receiver analog circuitry 910 via configurable interface signal lines 945. Interface signal lines 945 preferably include four configurable signal lines 950, 955, 960, and 965, although one may use other numbers of configurable signal lines, as desired, depending on a particular application. In addition to supplying the serial interface signals 920, the baseband processor circuitry 120 provides a control signal 915, shown as a power-down (PDNB) signal in FIG. 9A, to both the receiver digital circuitry 905 and the receiver analog circuitry 910. The receiver digital circuitry 905 and the receiver analog circuitry 910 preferably use the power-down (PDNB) signal as the control signal 915 to configure the functionality of the interface signal lines 945. In other words, the functionality of the interface signal lines 945 depends on the state of the control signal 915. Also, the initialization of the circuitry within the receive path and the transmit path of the transceiver occurs upon the rising edge of the PDNB signal. Note that the PDNB signal is preferably an active-low logic signal, although one may use a normal (i.e., an active-high) logic signal, as persons skilled in the art would understand. Note also that, rather than using the PDNB signal, one may use other signals to control the configuration of the interface signal lines 945, as desired.

[0132] In the power-down or serial interface mode (i.e., the control signal 915 (for example, PDNB) is in the logic low state), interface signal line 950 provides the serial clock (SCLK) and interface signal line 955 supplies the serial interface enable signal (SENB). Furthermore, interface signal line 960 provides the serial data-in signal (SDI), whereas interface signal line 965 supplies the serial data-out (SDO) signal. One may devise other embodiments according to the invention in which, during this mode of operation, the transceiver may also perform circuit calibration and adjustment procedures, as desired (for example, the values of various transceiver components may vary over time or among transceivers produced in different manufacturing batches. The transceiver may calibrate and adjust its circuitry to take those variations into account and provide higher performance).

[0133] In the normal receive mode of operation (i.e., the control signal, PDNB, is in the logic-high state), interface signal line 950 provides a negative clock signal (CKN) and interface signal line 955 supplies the positive clock signal (CKP). Furthermore, interface signal line 960 provides a negative data signal (ION), whereas interface signal line 965 supplies a positive data signal (IOP).

[0134] In preferred embodiments of the invention, the CKN and CKP signals together form a differential clock signal that the receiver digital circuitry 905 provides to the receiver analog circuitry 910. The receiver analog circuitry 910 may provide the clock signal to the transmitter circuitry within the RF transceiver in order to facilitate calibration

and adjustment of circuitry, as described above. During the receive mode, the receiver analog circuitry 910 provides the ION and IOP signals to the receiver digital circuitry 905. The ION and IOP signals preferably form a differential data signal. As noted above, the transceiver disables the transmitter circuitry during the receive mode of operation.

[0135] In preferred embodiments according to the invention, clock signals CKN and CKP are turned off when the transmitter circuitry is transmitting signals. During the transmit mode, interface signal lines 960 and 965 preferably provide two logic signals from the receiver digital circuitry 905 to the receiver analog circuitry 910. The signal lines may provide input/output signals to communicate data, status, information, flag, and configuration signals between the receiver digital circuitry 905 and the receiver analog circuitry 910, as desired. Preferably, the logic signals control the output buffer of the transmit VCO circuitry. Note that, rather than configuring interface signal lines 960 and 965 as logic signal lines, one may configure them in other ways, for example, analog signal lines, differential analog or digital signal lines, etc., as desired. Furthermore, the interface signal lines 960 and 965 may provide signals from the receiver digital circuitry 905 to the receiver analog circuitry 910, or vice-versa, as desired.

[0136] In addition to using differential signals, RF transceivers according to the invention preferably take other measures to reduce interference effects among the various transceiver circuits. Signals CKN, CKP, ION, and IOP may constitute voltage signals, as desired. Depending on the application, the signals CKN, CKP, ION, and IOP (or logic signals in the transmit mode) may have low voltage swings (for example, voltage swings smaller than the supply voltage) to reduce the magnitude and effects of interference because of the voltage switching on those signals.

[0137] In preferred embodiments according to the invention, signals CKN, CKP, ION, and IOP constitute current, rather than voltage, signals. Moreover, to help reduce the effects of interference even further, RF transceivers according to the invention preferably use band-limited signals. RF transceivers according to the invention preferably use filtering to remove some of the higher frequency harmonics from those signals to produce band-limited current signals.

[0138] Table 3 below summarizes the preferred functionality of the configurable interface signal lines 950, 955, 960, and 965 as a function of the state of the control signal 915 (for example, PDNB):

TABLE 3

Signal Line	Control = 0	Control = 1	Control = 1
		(During Reception)	(During Transmission)
950	SCLK	CKN	(CKN off)
955	SENB	CKP	(CKP off)
960	SDI	ION	Logic Signal
965	SDO	IOP	Logic Signal

[0139] Using configurable interface signal lines 945 in the interface between the receiver digital circuitry 905 and the receiver analog circuitry 910 allows using the same physical connections (e.g., pins on an integrated-circuit device or electrical connectors on a module) to accomplish different

functionality. Thus, the configurable interface between the receiver digital circuitry 905 and the receiver analog circuitry 910 makes available the physical electrical connections available for other uses, for example, providing ground pins or connectors around sensitive analog signal pins or connectors to help shield those signals from RF interference. Moreover, the configurable interface between the receiver digital circuitry 905 and the receiver analog circuitry 910 reduces packaging size, cost, and complexity.

[0140] FIG. 9B shows an embodiment 900B that includes a configurable interface according to the invention. Here, the baseband processor circuitry 120 subsumes the functionality of the receiver digital circuitry 905. The baseband processor circuitry 120 realizes the functionality of the receiver digital circuitry 905, using hardware, software, or both, as desired. Because the baseband processor circuitry 120 has subsumed the receiver digital circuitry 905, the baseband processor circuitry 120 may communicate with the receiver analog circuitry 910 using configurable interface signal lines 945, depending on the state of the control signal 915 (e.g., the PDNB signal). The configurable interface signal lines 945 perform the same functions described above in connection with FIG. 9A, depending on the state of the control signal 915. As noted above, one may reconfigure the interface signal lines 960 and 965 during transmit mode to implement desired functionality, for example, logic signals.

[0141] FIG. 10 shows a conceptual block diagram of an embodiment 1000 of a configurable interface according to the invention within an RF transceiver in the power-down or serial interface mode (i.e., the control signal 915 is in a logic-low state). A logic low state on the control signal 915 enables the driver circuitry 1012A, 1012B, and 1012C, thus providing the configurable serial interface signal lines 950, 955, and 960 to the receiver analog circuitry 910. Similarly, the logic low state on the control signal 915 causes the AND gates 1030A, 1030B, and 1030C to provide configurable interface signal lines 950, 955, and 960 to other circuitry within the receiver analog circuitry 910. The outputs of the AND gates 1030A, 1030B, and 1030C comprise a gated SCLK signal 1032, a gated SENB signal 1034, and a gated SDI signal 1036, respectively.

[0142] Interface controller circuitry 1040 accepts as inputs the gated SCLK signal 1032, the gated SENB signal 1034, and the gated SDI signal 1036. The interface controller circuitry 1040 resides within the receiver analog circuitry 910 and produces a receiver analog circuitry SDO signal 1044 and an enable signal 1046. By controlling tri-state driver circuitry 1042, the enable signal 1046 controls the provision of the receiver analog circuitry SDO signal 1044 to the receiver digital circuitry 905 via the configurable interface signal line 965.

[0143] Interface controller circuitry 1010 within the receiver digital circuitry 905 accepts the SCLK signal 925, the SENB signal 930, and the SDI signal 935 from the baseband processor circuitry 120. By decoding those signals, the interface controller circuitry 1010 determines whether the baseband processor circuitry 120 intends to communicate with the receiver digital circuitry 905 (e.g., the baseband processor circuitry 120 attempts to read a status or control register present on the receiver digital circuitry 905). If so, the interface controller circuitry 1010 provides the SCLK signal 925, the SENB signal 930, and the SDI signal

935 to other circuitry (not shown explicitly) within the receiver digital circuitry 905 for further processing.

[0144] Interface controller circuitry 1010 provides as output signals a receiver digital circuitry SDO signal 1018, a select signal 1020, and an enable signal 1022. The receiver digital circuitry SDO signal 1018 represents the serial data-out signal for the receiver digital circuitry 905, i.e., the serial data-out signal that the receiver digital circuitry 905 seeks to provide to the baseband processor circuitry 120. The interface controller circuitry 1010 supplies the select signal 1020 to multiplexer circuitry 1014. The multiplexer circuitry 1014 uses that signal to selectively provide as the multiplexer circuitry output signal 1024 either the receiver digital circuitry SDO signal 1018 or the receiver analog circuitry SDO signal 1044, which it receives through configurable interface signal line 965. Tri-state driver circuitry 1016 provides the multiplexer circuitry output signal 1024 to the baseband processor circuitry 120 under the control of the enable signal 1022.

[0145] Tri-state driver circuitry 1012A, 1012B, and 1012C use an inverted version of the control signal 915 as their enable signals. Thus, a logic high value on the control signal 915 disables the driver circuitry 1012A, 1012B, and 1012C, thus disabling the serial interface between the receiver digital circuitry 905 and the receiver analog circuitry 910. Similarly, AND gates 1030A, 1030B, and 1030C use an inverted version of the control signal 915 to gate interface signal lines 950, 955, and 960. In other words, a logic high value on the control signal 915 inhibits logic switching at the outputs of AND gates 1030A, 1030B, and 1030C, which reside on the receiver analog circuitry 910.

[0146] FIG. 11A shows a conceptual block diagram of an embodiment 1100A of a configurable interface according to the invention, in an RF transceiver operating in the normal receive mode of operation (i.e., the control signal 915 is in a logic-high state). As noted above, in this mode, the receiver digital circuitry 905 provides a clock signal to the receiver analog circuitry 910 through the configurable interface signal lines 950 and 955. Configurable interface signal line 950 provides the CKN signal, whereas configurable interface signal line 955 supplies the CKP signal. Also in this mode, the receiver analog circuitry 910 provides a data signal to the receiver digital circuitry 905 through the configurable interface signal lines 960 and 965.

[0147] The receiver digital circuitry 905 provides the CKN and CKP signals to the receiver analog circuitry 910 by using clock driver circuitry 1114. The clock driver circuitry 1114 receives a clock signal 1112A and a complement clock signal 1112B from signal processing circuitry 1110. Signal processing circuitry 1110 receives the reference signal 220 and converts it to the clock signal 1112A and complement clock signal 1112B. Interface controller circuitry 1116 provides an enable signal 1118 that controls the provision of the CKN and CKP clock signals to the receiver analog circuitry 910 via the interface signal lines 950 and 955, respectively.

[0148] Receiver analog circuitry 910 includes clock receiver circuitry 1130 that receives the CKN and CKP clock signals and provides a clock signal 1132A and a complement clock signal 1132B. Interface controller circuitry 1140 within the receiver analog circuitry 910 provides an enable signal 1142 that controls the operation of the clock receiver circuitry 1130.

[0149] The clock signal **1132A** clocks the ADC circuitry **1144**, or other circuitry (for example, calibration circuitry), or both, as desired. Note that, rather than using the clock signal **1132A**, one may use the complement clock signal **1132B**, or both the clock signal **1132A** and the complement clock signal **1132B**, by making circuit modifications as persons skilled who have the benefit of the description of the invention understand. The ADC circuitry **1144** provides to multiplexer circuitry **1150** a one-bit differential in-phase digital signal **1146A** and a one-bit differential quadrature digital signal **1146B**. The multiplexer circuitry **1150** provides a one-bit differential digital output signal **1152** to data driver circuitry **1154**. The output signal **1152** therefore constitutes multiplexed I-channel data and Q-channel data. The data driver circuitry **1154** supplies the differential data signal comprising ION and IOP to the receiver digital circuitry **905**, using the configurable interface signal lines **960** and **965**, respectively.

[0150] The clock signal **1132A** also acts as the select signal of multiplexer circuitry **1150**. On alternating edges of the clock signal **1132A**, the multiplexer circuitry **1150** selects, and provides to, the data driver circuitry **1154** the one-bit differential in-phase digital signal **1146A** (i.e., I-channel data) and the one-bit differential quadrature digital signal **1146B** (i.e., Q-channel data). The interface controller circuitry **1140** supplies an enable signal **1156** to the data driver circuitry **1154** that controls the provision of the configurable interface signal **960** and the configurable interface signal **965** to the receiver digital circuitry **905** via the configurable interface signal lines **960** and **965**.

[0151] The receiver digital circuitry **905** includes data receiver circuitry **1120**. Data receiver circuitry **1120** accepts from the receiver analog circuitry **910** the signals provided via the configurable interface signal lines **960** and **965**. The data receiver circuitry **1120** provides a pair of outputs **1122A** and **1122B**. An enable signal **1124**, supplied by the interface controller circuitry **1116**, controls the operation of the data receiver circuitry **1120**.

[0152] The receiver digital circuitry **905** also includes a delay-cell circuitry **1119** that accepts as its inputs the clock signal **1112A** and the complement clock signal **1112B**. The delay-cell circuitry **1119** constitutes a delay-compensation circuit. In other words, ideally, the signal-propagation delay of the delay-cell circuitry **1119** compensates for the delays the signals experience as they propagate from the receiver digital circuitry **905** to the receiver analog circuitry **910**, and back to the receiver digital circuitry **905**.

[0153] The delay-cell circuitry **1119** provides as its outputs a clock signal **1121A** and a complement clock signal **1121B**. The clock signal **1121A** and the complement clock signal **1121B** clock a pair of D flip-flop circuitries **1123A** and **1123B**, respectively. The D flip-flop circuitries **1123A** and **1123B** latch the output **1122A** of the data receiver circuitry **1120** alternately. In other words, the clock signal **1121A** causes the latching of the I-channel data by the D flip-flop circuitry **1123A**, whereas the complement clock signal **1121B** causes the D flip-flop circuitry **1123B** to latch the Q-channel data.

[0154] The output signals of the delay-cell circuitry **1119** help the receiver digital circuitry **905** to sample the I-channel data and the Q-channel data that it receives from the receiver analog circuitry **910**. The receiver digital circuitry

905 receives multiplexed I-channel data and the Q-channel data through the ION signal **960** and the IOP signal **965**. Thus, the D flip-flop circuitries **1123A** and **1123B** perform a de-multiplexing function on the multiplexed I-channel data and Q-channel data.

[0155] In the normal receive or transmit modes, (i.e., the control signal **915** is in the logic-high state), interface signal line **950** provides the negative clock signal (CKN) and interface signal line **955** supplies the positive clock signal (CKP). In preferred embodiments of the invention, the CKN and CKP signals together form a differential clock signal that the receiver digital circuitry **905** provides to the receiver analog circuitry **910**.

[0156] During the receive mode, interface signal line **960** provides the negative data signal (ION), whereas interface signal line **965** supplies the positive data signal (IOP). The ION and IOP signals preferably form a differential data signal.

[0157] In the transmit mode, the data signal may function as an input/output signal to communicate data, status, information, flag, and/or configuration signals between the receiver digital circuitry **905** and the receiver analog circuitry **910**. Preferably, the interface signal lines **960** and **965** function as two logic signal lines in the transmit mode. As noted above, the transceiver disables the receiver circuitry during the transmit mode of operation. In RF transceivers partitioned according to the invention (see, e.g., FIGS. 2A-2D, 4, and 8), the clock receiver circuitry **1130** may provide the clock signal **1132A**, the complement clock signal **1132B**, or both, to transmitter circuitry (partitioned together with the receiver analog circuitry **910**) for circuit calibration, circuit adjustment, and the like, as described above.

[0158] In the transmit mode, once circuit calibration and adjustment has concluded, however, the clock driver circuitry **1114** uses the enable signal **1118** to inhibit the propagation of the CKN and CKP clock signals to the receiver analog circuitry **910**. In this manner, the clock driver circuitry **1114** performs the function of the switch **492** in FIGS. 4 and 8. Note that, during the normal transmit mode of operation, the ADC circuitry **1144** does not provide any data to the receiver digital circuitry **905** via the ION and IOP signals because, according to the TDD protocol, the receiver path circuitry is inactive during the normal transmit mode of operation. Instead, the receiver digital circuitry **905** provides control signals to the receiver analog circuitry **910** via interface signal lines **960** and **965**.

[0159] During the transmit mode, the interface controller circuitry **1116** provides control signals via signal lines **1160** to the interface signal lines **960** and **965**. The interface controller circuitry **1140** receives the control signals via signal lines **1165** and provides them to various blocks within the receiver analog circuitry, as desired. During the receive mode, the interface controller circuitry **1116** inhibits (e.g., high-impedance state) the signal lines **1160**. Similarly, the interface controller circuitry **1140** inhibits the signal lines **1165** during the receive mode.

[0160] For the purpose of conceptual illustration, FIG. 11A shows the interface controller circuitry **1116** and the interface controller circuitry **1140** as two blocks of circuitry distinct from the interface controller circuitry **1010** and the

interface controller circuitry **1040** in **FIG. 10**, respectively. One may combine the functionality of the interface controller circuitry **1010**, as desired. Likewise, one may combine the functionality of interface controller circuitry **1140** with the functionality of the interface controller circuitry **1040**, as desired. Moreover, one may combine the functionality of the signal processing circuitries **1110** with the functionality of the interface controller circuitry **1116** and the interface controller circuitry **1140**, respectively. Combining the functionality of those circuits depends on various design and implementation choices, as persons skilled in the art understand.

[0161] **FIG. 11B** illustrates a block diagram of a preferred embodiment **1100B** of a delay-cell circuitry **1119** according to the invention. The delay-cell circuitry **1119** includes a replica of the clock driver circuitry **1114A** in tandem with a replica of the data receiver circuitry **1120A**. In other words, the block labeled “**1114A**” is a replica of the clock driver circuitry **1114**, and the block labeled “**1120A**” is a replica of the data receiver circuitry **1120**. (Note that the delay-cell circuitry **1119** may alternatively include a replica of the data driver circuitry **1154** in tandem with a replica of the clock receiver circuitry **1130**.) The replica of the clock driver circuitry **1114A** accepts the clock signal **1112A** and the complement clock signal **1112B**. The replica of the clock driver circuitry **1114A** provides its outputs to the replica of the data receiver circuitry **1120A**. The replica of the data receiver circuitry **1120A** supplies the clock signal **1121A** and the complement clock signal **1121B**. The clock signal **1121A** and the complement clock signal **1121B** constitute the output signals of the delay-cell circuitry **1119**. The delay-cell circuitry **1119** also receives as inputs enable signals **1118** and **1124** (note that **FIG. 11A** does not show those input signals for the sake of clarity). The enable signal **1118** couples to the replica of the clock driver circuitry **1114A**, whereas the enable signal **1124** couples to the replica of the data receiver circuitry **1120A**.

[0162] Note that **FIG. 11B** constitutes a conceptual block diagram of the delay-cell circuitry **1119**. Rather than using distinct blocks **1114A** and **1120A**, one may alternatively use a single block that combines the functionality of those two blocks, as desired. Moreover, one may use a circuit that provides an adjustable, rather than fixed, delay, as desired. Note also that the embodiment **1100B** of the delay-cell circuitry **1119** preferably compensates for the delay in the clock driver circuitry **1114** in **FIG. 11A**. In other words, the delay-cell circuitry **1119** preferably compensates sufficiently for the round-trip delay in the signals that travel from the receiver digital circuitry **905** to the receiver analog circuitry **910** and back to the receiver digital circuitry **905** to allow for accurate sampling in the receiver digital circuitry of the I-channel data and the Q-channel data. Note that in the embodiment **1100B**, the replica of the clock driver circuitry **1114A** mainly compensates for the round-trip delay, whereas the replica of the data receiver circuitry **1120A** converts low-swing signals at the output of the replica of the clock driver circuitry **1114A** into full-swing signals.

[0163] The receiver digital circuitry **905** and the receiver analog circuitry **910** preferably reside within separate integrated-circuit devices. Because those integrated-circuit devices typically result from separate semiconductor fabrication processes and manufacturing lines, their process

parameters may not match closely. As a result, the preferred embodiment **1100B** of the delay-cell circuitry **1119** does not compensate for the delay in the clock receiver circuitry **1130**, the data driver circuitry **1154**, and the data receiver circuitry **1120** in **FIG. 11A**.

[0164] Note, however, that if desired, the delay-cell circuitry **1119** may also compensate for the signal delays of the clock receiver circuitry **1130**, the data driver circuitry **1154**, and the data receiver circuitry **1120**. Thus, in situations where one may match the process parameters of the receiver digital circuitry **905** and the receiver analog circuitry **910** relatively closely (for example, by using thick-film modules, silicon-on-insulator, etc.), the delay-cell circuitry **1119** may also compensate for the delays of other circuit blocks. As another alternative, one may use a delay-cell circuitry **1119** that provides an adjustable delay and then program the delay based on the delays in the receiver digital circuitry **905** and the receiver analog circuitry **910** (e.g., provide a matched set of receiver digital circuitry **905** and receiver analog circuitry **910**), as persons skilled in the art who have the benefit of the description of the invention understand. Furthermore, rather than an open-loop arrangement, one may use a closed-loop feedback circuit implementation (e.g., by using a phase-locked loop circuitry) to control and compensate for the delay between the receiver analog circuitry **910** and the receiver digital circuitry **905**, as desired.

[0165] Note that the digital circuit blocks shown in **FIGS. 11A** and **11B** depict mainly the conceptual functions and signal flow. The actual circuit implementation may or may not contain separately identifiable hardware for the various functional blocks. For example, one may combine the functionality of various circuit blocks into one circuit block, as desired.

[0166] **FIG. 12** shows a schematic diagram of a preferred embodiment **1200** of a signal-driver circuitry according to the invention. One may use the signal-driver circuitry as the clock driver circuitry **1114** and the data driver circuitry **1154** in **FIG. 11A**. In the latter case, the input signals to the signal-driver circuitry constitute the output signals **1152** and the enable signal **1156**, whereas the output signals of the signal-receiver circuitry constitute the ION and IOP signals **960** and **965**, respectively, in **FIG. 11A**.

[0167] The signal-driver circuitry in **FIG. 12** constitutes two circuit legs. One circuit leg includes MOSFET devices **1218** and **1227** and resistor **1230**. The second leg includes MOSFET devices **1242** and **1248** and resistor **1251**. The input clock signal controls MOSFET devices **1218** and **1242**. Current source **1206**, MOSFET devices **1209** and **1215**, and resistor **1212** provide biasing for the two circuit legs.

[0168] MOSFET devices **1227** and **1248** drive the CKN and CKP output terminals through resistors **1230** and **1251**, respectively. Depending on the state of the clock signal, one leg of the signal-driver circuitry conducts more current than the other leg. Put another way, the signal-driver circuitry steers current from one leg to the other in response to the clock signal (i.e., in response to the clock signal, one leg of the circuit turns on and the other leg turns off, and vice-versa). As a result, the signal-driver circuitry provides a differential clock signal that includes current signals CKN and CKP.

[0169] If the enable signal is high, MOSFET device **1203** is off and therefore does not affect the operation of the rest

of the circuit. In that case, a current I_o flows through the current source **1206** and diode-connected MOSFET device **1209**. The flow of current generates a voltage at the gate of MOSFET device **1209**. MOSFET devices **1227** and **1248** share the same gate connection with MOSFET device **1209**. Thus, MOSFET devices **1227** and **1248** have the same gate-source voltage, V_{gs} , as MOSFET device **1209** when the appropriate MOSFET devices are in the on state. MOSFET devices **1218** and **1242** cause current steering between the first and second circuit legs. Only one of the MOSFET devices **1218** and **1242** is in the on state during the operation of the circuit. Depending on which MOSFET device is in the on state, the mirroring current I_o flows through the circuit leg that includes the device in the on state.

[0170] Resistors **1221** and **1239** provide a small trickle current to the circuit leg that includes the MOSFET device (i.e., MOSFET device **1218** or MOSFET device **1242**) that is in the off state. The small trickle current prevents the diode-connected MOSFET devices in the signal receiver circuitry (see **FIG. 13**) from turning off completely. The trickle current helps to reduce the delay in changing the state of the circuit in response to transitions in the input clock signal. The trickle currents also help to reduce transient signals at the CKP and CKN terminals and, thus, reduce interference effects.

[0171] Capacitors **1224** and **1245** provide filtering so that when MOSFET device **1218** and MOSFET device **1242** switch states, the currents through the first and second circuit legs (CKN and CKP circuit legs) do not change rapidly. Thus, capacitors **1224** and **1245** reduce the high-frequency content in the currents flowing through the circuit legs into the CKN and CKP terminals. The reduced high-frequency (i.e., band-limited) content of the currents flowing through the CKN and CKP terminals helps reduce interference effects to other parts of the circuit, for example, the LNA circuitries, as described above. Capacitors **1233** and **1236** and resistors **1230** and **1251** help to further reduce the high-frequency content of the currents flowing through the CKN and CKP terminals. Thus, the circuit in **FIG. 12** provides smooth steering of current between the two circuit legs and therefore reduces interference effects with other circuitry.

[0172] When the enable signal goes to the low state, MOSFET device **1203** turns on and causes MOSFET device **1209** to turn off. MOSFET devices **1227** and **1248** also turn off, and the circuit becomes disabled. Note that the enable signal may be derived from the power-down PDNB signal.

[0173] **FIG. 13A** shows a schematic diagram of an exemplary embodiment **1300A** of a signal-receiver circuitry according to the invention. One may use the signal-receiver circuitry as the clock receiver circuitry **1130** and the data receiver circuitry **1120** in **FIG. 11A**. In the latter case, the input signals to the signal-receiver circuitry constitute the ION and IOP signals **960** and **965** and the enable signal **1124**, whereas the output signals constitute the signals at the outputs **1122A** and **1122B**, respectively, in **FIG. 11A**.

[0174] The signal receiver circuitry in **FIG. 13A** helps to convert differential input currents into CMOS logic signals. The signal-receiver circuitry in **FIG. 13A** constitutes two circuit legs. The first circuit leg includes MOSFET devices **1303**, **1342**, and **1345**. The second leg includes MOSFET devices **1309**, **1324**, and **1327**. Note that, preferably, the

scaling of MOSFET devices **1303** and **1309** provides a current gain of 1:2 between them. Likewise, the scaling of MOSFET devices **1330** and **1327** preferably provides a current gain of 1:2 between them. The current gains help to reduce phase noise in the signal-receiver circuitry.

[0175] MOSFET devices **1339**, **1342**, **1333**, and **1324** provide enable capability for the circuit. When the enable input is in the high state, MOSFET devices **1339**, **1342**, **1333**, and **1324** are in the on state. MOSFET devices **1345** and **1336** are current mirrors, as are MOSFET devices **1303** and **1309**. MOSFET devices **1330** and **1327** also constitute current mirrors.

[0176] The currents flowing through the CKN and CKP terminals mirror to the MOSFET devices **1327** and **1309**. The actual current flowing through the second circuit leg depends on the currents that MOSFET device **1327** and MOSFET device **1309** try to conduct; the lower of the two currents determines the actual current that flows through the second circuit leg.

[0177] The difference between the currents that MOSFET device **1327** and MOSFET device **1309** try to conduct flows through the parasitic capacitance at node **1360**. The current flow charges or discharges the capacitance at node **1360**, thus making smaller the drain-source voltage (V_{ds}) of whichever of MOSFET devices **1327** and **1309** that seeks to carry the higher current. Ultimately, the lower of the currents that MOSFET devices **1327** and **1309** seek to conduct determines the current through the second leg of the circuit.

[0178] A pair of inverters **1312** and **1315** provide true and complement output signals **1351** and **1348**, respectively. The signal receiver circuitry therefore converts differential input currents into CMOS logic output signals.

[0179] In exemplary embodiments of the invention, the signal receiver circuitry provides fully differential output signals. **FIG. 13B** shows an embodiment **1300B** of such a signal receiver circuitry. One may use embodiment **1300B** in a similar manner and application as embodiment **1300A**, using the same input signals, as desired. Unlike embodiment **1300A**, however, embodiment **1300B** includes fully differential circuitry to generate fully differential output signals.

[0180] Embodiment **1300B** includes the same devices as does embodiment **1300A**, and the common devices operate in a similar manner. Furthermore, embodiment **1300B** includes additional devices and components. Embodiment **1300B** constitutes two circuit legs and replica of those circuit legs. The first circuit leg includes MOSFET devices **1303**, **1342**, and **1345**. The replica of the first circuit leg includes devices **1355**, **1379**, and **1381**. The second circuit leg includes MOSFET devices **1309**, **1324**, and **1327**. The replica of the second circuit leg include devices **1357**, **1363**, and **1365**. The scaling of MOSFET devices **1303** and **1309** provides a current gain of 1:2 between them, as does the scaling of MOSFET devices **1330** and **1327**. Likewise, scaling of MOSFET devices **1355** and **1357** provides a current gain of 1:2 between them, as does the scaling of MOSFET devices **1336** and **1365**. The current gains help to reduce phase noise in the signal-receiver circuitry.

[0181] Embodiment **1300B** generally operates similarly to embodiment **1300A**. Devices **1381**, **1379**, **1355**, **1353**, **1357**, **1363**, **1365**, **1367**, **1369**, **1359**, and **1361** perform the same functions as do devices **1345**, **1342**, **1303**, **1306**, **1309**, **1324**,

1327, 1321, 1318, 1312, and 1315, respectively. The enable function also operates similarly to embodiment **1300A**. Resistors **1371 and 1375** and capacitors **1373 and 1377** filter the input clock (e.g., 13 MHz clock). Inverters **1312, 1315, 1361, and 1359** provide fully differential true and complement output signals.

[0182] FIG. 14 shows an embodiment **1400** of an alternative signal-driver circuitry according to **10** the invention. The signal-driver circuitry in FIG. 14 includes two circuit legs. The first circuit leg includes MOSFET device **1406** and resistor **1415A**. The second circuit leg includes MOSFET device **1409** and resistor **1415B**. A current source **1403** supplies current to the two circuit legs.

[0183] The input clock signal controls MOSFET devices **1406** and **1409**. MOSFET devices **1406** and **1409** drive the CKP and CKN output terminals, respectively. Depending on the state of the clock signal, one leg of the signal-driver circuitry conducts current. Put another way, the signal-driver circuitry steers current from one leg to the other in response to the clock signal. As a result, the signal-driver circuitry provides a differential clock signal that includes signals CKN and CKP. Capacitor **1412** filters the output signals CKN and CKP. Put another way, capacitor **1412** provides band-limiting of the output signals CKN and CKP. Note that the current source **1403** supplies limited-amplitude signals by providing current through resistors **1415A** and **1415B**.

[0184] Note that the signal-driver circuitries (clock driver and data driver circuitries) according to the invention preferably provide current signals CKN and CKP. Similarly, signal-receiver circuitries (clock receiver and data receiver circuitries) according to the invention preferably receive current signals. As an alternative, one may use signal-driver circuitries that provide as their outputs voltage signals, as desired. One may also implement signal-receiver circuitries that receive voltage signals, rather than current signals. As noted above, depending on the application, one may limit the frequency contents of those voltage signals, for example, by filtering, as desired.

[0185] Generally, several techniques exist for limiting noise, for example, digital switching-noise, in the interface between the receiver analog circuitry and the receiver digital circuitry according to the invention. Those techniques include using differential signals, using band-limited signals, and using amplitude-limited signals. RF apparatus according to the invention may use any or all of those techniques, as desired. Furthermore, one may apply any or all of those techniques to interface circuitry that employs voltage or current signals, as persons of ordinary skill in the art who have the benefit of the description of the invention understand.

[0186] Note also that the RF transceiver embodiments according to the invention lend themselves to various choices of circuit implementation, as a person skilled in the art who have the benefit of the description of the invention understand. For example, as noted above, each of the circuit partitions, or circuit blocks, of RF transceivers partitioned according to the invention, resides preferably within an integrated circuit device. Persons skilled in the art, however, will appreciate that the circuit partitions, or circuit blocks, may alternatively reside within other substrates, carriers, or packaging arrangements. By way of illustration, other partitioning arrangements may use modules, thin-film modules,

thick-film modules, isolated partitions on a single substrate, circuit-board partitions, and the like, as desired, consistent with the embodiments of the invention described here.

[0187] One aspect of the invention contemplates partitioning RF transceivers designed to operate within several communication channels (e.g., GSM, PCS, and DCS). Persons skilled in the art, however, will recognize that one may partition according to the invention RF transceivers designed to operate within one or more other channels, frequencies, or frequency bands, as desired.

[0188] Moreover, the partitioning of RF transceivers according to the invention preferably applies to RF apparatus (e.g., receivers or transceivers) with a low-IF, digital-IF architecture. Note, however, that one may apply the partitioning and interfacing concepts according to the invention to other RF receiver or transceiver architectures and configurations, as persons of ordinary skill in the art who have the benefit of the description of the invention understand. By way of illustration, one may use the partitioning and interface concepts according to the invention in RF apparatus that includes:

[0189] low-IF receiver circuitry;

[0190] low-IF receiver circuitry and offset-PLL transmitter circuitry;

[0191] low-IF receiver circuitry and direct up-conversion transmitter circuitry;

[0192] direct-conversion receiver circuitry;

[0193] direct-conversion receiver circuitry and offset-PLL transmitter circuitry; or

[0194] direct-conversion receiver circuitry and direct up-conversion transmitter circuitry.

[0195] As an example of the flexibility of the partitioning concepts according to the invention, one may include the LO circuitry in one partition, the receiver digital circuitry in a second partition, and the transmitter up-converter circuitry and the receiver analog circuitry in a third partition. As another illustrative alternative, one may include the LO circuitry and the transmitter up-converter circuitry within one circuit partition, depending on the noise and interference characteristics and specifications for a particular implementation.

[0196] Note that, in a typical direct-conversion RF receiver or transceiver implementation, the receiver digital circuitry would not include the digital down-converter circuitry (the receiver analog circuitry, however, would be similar to the embodiments described above). Furthermore, in a typical direct up-conversion transmitter circuitry, one would remove the offset PLL circuitry and the transmit VCO circuitry from the transmitter circuitry. The LO circuitry would supply the RF LO signal to the up-conversion circuitry of the transmitter circuitry, rather than the offset-PLL circuitry. Also, in a direct up-conversion implementation, the LO circuitry typically does not provide an IF LO signal.

[0197] Furthermore, as noted above, one may use the partitioning and interface concepts according to the invention not only in RF transceivers, but also in RF receivers for high-performance applications. In such RF receivers, one may partition the receiver as shown in FIGS. 2A-2D and 4-8, and as described above. In other words, the RF receiver may

have a first circuit partition that includes the receiver analog circuitry, and a second circuit partition that includes the receiver digital circuitry.

[0198] The RF receiver may also use the digital interface between the receiver analog circuitry and the receiver digital circuitry, as desired. By virtue of using the receiver analog circuitry and the receiver digital circuitry described above, the RF receiver features a low-IF, digital-IF architecture. In addition, as noted above with respect to RF transceivers according to the invention, depending on performance specifications and design goals, one may include all or part of the local oscillator circuitry within the circuit partition that includes the receiver analog circuitry, as desired. Partitioning RF receivers according to the invention tends to reduce the interference effects between the circuit partitions.

[0199] As noted above, although RF apparatus according to the invention use a serial interface between the receiver analog circuitry and the receiver digital circuitry, one may use other types of interface, for example, parallel interfaces, that incorporate different numbers of signal lines, different types and sizes of signals, or both, as desired. Moreover, the clock driver circuitries and the data driver circuitries may generally constitute signal-driver circuitries that one may use in a variety of digital interfaces between the receiver analog circuitry and the receiver digital circuitry according to the invention.

[0200] Likewise, the clock receiver circuitries and data receiver circuitries may generally constitute signal-receiver circuitries that one may use in a variety of digital interfaces between the receiver analog circuitry and the receiver digital circuitry according to the invention. In other words, one may use signal-driver circuitries and signal-receiver circuitries to implement a wide variety of digital interfaces, as persons of ordinary skill who have the benefit of the description of the invention understand.

[0201] As described above in detail, RF apparatus (such as receivers and transceivers) perform some of the processing of the input RF signal in the digital domain and provide resulting digital signals, for example, to a baseband processor circuitry. The receiver digital circuitry according to the invention, such as receiver digital circuitry shown in **FIGS. 2 and 4-8**, performs several tasks as described below in detail.

[0202] First, in certain interfaces where the baseband processor circuitry accepts analog signals, the receiver digital circuitry may convert the processed digital signals to analog output signals, as desired. Second, the receiver digital circuitry translates the signal spectrum from an intermediate frequency to baseband (i.e., centered around zero frequency or DC). Third, the receiver digital circuitry applies a programmable gain to the processed signals so that the amplitude of its output signals falls within a certain range suitable for the baseband processor circuitry, as desired. Fourth, the receiver digital circuitry removes residual DC offsets that result from non-ideal circuit behavior in the receiver analog circuitry. The removal of the residual DC offsets according to the invention operates in the presence of interference signals (e.g., interferers and blockers) and the desired signal. Fifth, the receiver digital circuitry filters out undesired energy present in its input signals.

[0203] The undesired energy may originate from a number of sources, such as the quantization noise of the ADC

circuitry in the receiver analog circuitry (see **FIGS. 2 and 4-8** and their respective discussions), and RF noise and spurious signals. The undesired RF energy may fall within the signal band of interest, as well as outside of it.

[0204] The RF noise and spurious signals include interferers and blockers. GSM specification provide a for a channel spacing of **200 kHz**. An interferer constitutes a signal in the desired signal band of interest that results from another GSM user's operation of RF apparatus that inject energy within the RF spectrum. Blockers refer to spurious RF signals that originate from apparatus that operates outside or inside the GSM band. Blockers may result from other RF apparatus, such as military radios, global positioning satellite (GPS) systems, and other users of the electromagnetic spectrum. The digital filter circuitry in the receiver digital circuitry filters and attenuates energy from interferers and blockers.

[0205] The quantization noise of the ADC circuitry constitutes another source of undesired energy. Exemplary embodiments of RF apparatus according to the invention include measures that aim to reduce interference with the desired signal by the quantization noise of the ADC circuitry. **FIG. 15** shows a typical plot of the spectrum of the signal of interest that constitutes part of the output signal of the receiver analog circuitry. As noted above, exemplary embodiments of the invention employ a 100 kHz IF frequency. In **FIG. 15**, the spectrum of the signal of interest spans a 200 kHz band of frequencies from DC to +200 kHz. The spectrum centers around the IF frequency, f_{IF} . The quantization noise of the ADC circuitry appears mainly below DC and above 200 kHz.

[0206] To reduce interference with the desired signal band, the sigma-delta ADC circuitry in it exemplary embodiments of RF apparatus according to the invention employ noise-shaping techniques. The noise-shaping techniques shape the characteristics of the quantization noise of the ADC circuitry so as to move the quantization noise out of the signal band of interest, e.g., DC to 200 kHz. **FIG. 16** shows a typical plot of the quantization noise power density for the ADC circuitry in exemplary embodiments of the invention. Note that the quantization noise within the signal band of interest is several orders of magnitude lower than outside the signal band of interest.

[0207] As noted above, sigma-delta ADC circuitry provide one-bit digital outputs to the receiver digital circuitry. Those output signals constitute over-sampled digital signals. Typically, reducing quantization noise results from using more resolution (i.e., more bits) in the ADC circuitry. By using sigma-delta ADC circuitry, however, RF apparatus according to the invention spectrally shape the quantization noise so that it occupies frequency bands outside the signal band of interest, as persons skilled in the art who read this disclosure will understand.

[0208] Once it has received the one-bit in-phase and quadrature signals from the receiver analog circuitry, the receiver digital circuitry performs signal processing operations on those signals. **FIGS. 17A and 17B** show more detailed conceptual or functional block diagrams of exemplary embodiments of receiver digital circuitry according to the invention. Note that one may use either of receiver digital circuitry in **FIG. 17A** or the receiver digital circuitry in **FIG. 17B** as the receiver digital circuitries shown in

FIGS. 2 and 4-8. FIG. 17A illustrates a conceptual or functional block diagram of a receiver digital circuitry that includes a cascade of digital down-converter **427**, digital filter circuitry **436**, and optional DAC circuitry **445** (for interfacing to baseband processor circuitries that accept analog input signals, as described above). IF LO circuitry **1715** couples to digital down-converter circuitry **427** and provides IF LO in-phase signal **1718** and IF LO quadrature signal **1721** to the digital down-converter circuitry **427**.

[**0209**] The digital filter circuitry **436** includes cascaded integrator/comb (CIC) filter circuitry **1705A**, secondary filter circuitry **1710A**, CIC filter circuitry **1705B**, and secondary filter circuitry **1710B**. CIC filter circuitry **1705A** and secondary filter circuitry **1710A** provide the in-phase signal path within the digital filter circuitry **436**. Similarly, CIC filter circuitry **1705B** and secondary filter circuitry **1710B** provide the quadrature signal path within the digital filter circuitry **436**.

[**0210**] **FIG. 17B** shows a conceptual or functional block diagram of another receiver digital circuitry according to the invention. The receiver digital circuitry in **FIG. 17B** includes a cascade of digital down-converter circuitry **427**, digital filter circuitry **436**, PGA circuitries **836A-836B**, and optional DAC circuitry **445** (for interfacing to baseband processor circuitries that accept analog input signals, as described above). IF LO circuitry **1715** couples to digital down-converter circuitry **427** and provides IF LO in-phase signal **1718** and IF LO quadrature signal **1721** to the digital down-converter circuitry **427**.

[**0211**] The digital filter circuitry **436** includes cascaded integrator/comb (CIC) filter circuitry **1705A**, secondary filter circuitry **1710A**, CIC filter circuitry **1705B**, and secondary filter circuitry **1710B**. CIC filter circuitry **1705A** and secondary filter circuitry **1710A** provide the in-phase signal path within the digital filter circuitry **436**. Similarly, CIC filter circuitry **1705B** and secondary filter circuitry **1710B** provide the quadrature signal path within the digital filter circuitry **436**. PGA circuitry **836A** provides programmable gain for the in-phase signal path within the receiver digital circuitry. Likewise, PGA circuitry **836B** provides programmable gain for the quadrature signal path of the receiver digital circuitry.

[**0212**] One may control the programmable gain of PGA circuitries **836A-836B** in a variety of ways, as desired. In exemplary embodiments of the invention, the baseband processor circuitry (not shown explicitly in the figure) controls the PGA circuitries **836A-836B** in order to keep the signals provided to the baseband circuitry within a certain range. To do so, the baseband processor circuitry uses a gain-control algorithm that modifies the gain of the PGA circuitries **836A-836B** depending on the level of the signals that the receiver digital circuitry provides to the baseband circuitry. In other words, if the level of those signals is too low, the baseband circuitry increases the gain of the PGA circuitry **836A** and/or **836B**, and vice-versa. The details of the gain-control algorithm depend on the specifics of the baseband processor implementation, as persons of ordinary skill in the art would understand.

[**0213**] One may use in RF apparatus according to the invention receiver digital circuitry with architectures different than shown in **FIGS. 17A-17B**. For example, **FIGS. 18A and 18B** show conceptual or functional block diagrams of

alternative architectures of receiver digital circuitries for use in exemplary embodiments of the invention. Conceptually, the circuit arrangements shown in **FIGS. 18A and 18B** change the order of processing that the circuits in **FIGS. 17A and 17B** perform on the signals they receive from the receiver analog circuitry. Note that one may use either of receiver digital circuitry in **FIG. 18A** or the receiver digital circuitry in **FIG. 18B** as the receiver digital circuitries shown in **FIGS. 2 and 4-8**.

[**0214**] **FIG. 18A** illustrates a conceptual or functional block diagram of a receiver digital circuitry that includes a cascade of digital filter circuitry **436**, digital down-converter **427**, and optional DAC circuitry **445** (for interfacing to baseband processor circuitries that accept analog input signals, as described above). IF LO circuitry **1715** couples to digital down-converter circuitry **427** and provides IF LO in-phase signal **1718** and IF LO quadrature signal **1721** to the digital down-converter circuitry **427**.

[**0215**] Similar to the circuit in **FIG. 17A**, the digital filter circuitry **436** in **FIG. 18A** includes complex CIC filter circuitry **1805** and complex secondary filter circuitry **1810**. Unlike the circuit in **FIG. 17A**, however, the receiver digital circuitry in **FIG. 18A** first filters the input signals using the digital filter circuitry **436** and then mixes down the filtered signal to baseband by using the digital down-converter circuitry **427**.

[**0216**] **FIG. 18B** shows a conceptual or functional block diagram of an alternative architecture for a receiver digital circuitry according to the invention. Similar to the circuit arrangement in **FIG. 17B**, the receiver digital circuitry in **FIG. 18B** includes a cascade of digital filter circuitry **436**, digital down-converter circuitry **427**, PGA circuitries **836A-836B**, and optional DAC circuitry **445** (for interfacing to baseband processor circuitries that accept analog input signals, as described above), but in a different order. Like the circuit in **FIG. 17B**, the digital filter circuitry **436** in **FIG. 18B** includes CIC filter circuitry **1805** and secondary filter circuitry **1810**. IF LO circuitry **1715** couples to digital down-converter circuitry **427** and provides IF LO in-phase signal **1718** and IF LO quadrature signal **1721** to the digital down-converter circuitry **427**.

[**0217**] PGA circuitry **836** provides programmable gain for the in-phase signal path within the receiver digital circuitry. Likewise, PGA circuitry **836B** provides programmable gain for the quadrature signal path of the receiver digital circuitry. Similar to **FIG. 17B** described above, in exemplary embodiments of the invention, the baseband processor circuitry (not shown explicitly in the figure) controls the PGA circuitries **836A-836B** in **FIG. 18B** in order to keep the signals provided to the baseband circuitry within a certain range. To accomplish that goal, the baseband processor circuitry uses a gain-control algorithm that changes the gain of the PGA circuitries **836A-836B** depending on the level of the signals that the receiver digital circuitry provides to the baseband circuitry. In other words, if the level of those signals is too low, the baseband circuitry increases the gain of the PGA circuitries **836A** and/or **836B**, and vice-versa. The details of the gain-control algorithm depend on the specifics of the baseband processor implementation, as persons of ordinary skill in the art would understand.

[**0218**] As an alternative to the arrangement shown in **FIG. 18B**, one may place the PGA circuitries **836A-836B**

between the secondary filter circuitry **1810** and the digital down-converter circuitry **427**. By using feedback automatic gain control (AGC) to keep a constant level, the alternative embodiment reduces the number of signal bits provided to the digital down-converter circuitry **427**. Consequently, one may implement the digital down-converter circuitry **427** in a simpler, less expensive manner.

[0219] Generally, note that one may re-use hardware resources to implement the PGA circuitries **836A-836B** (for example, by using a multiplier circuitry within a DSP engine, as described below in detail) in various embodiments of the invention, as desired. By doing so, one may obtain improved signal flow. Furthermore, exemplary embodiments of the invention use IIR-type filter circuitries as the secondary filter circuitries. One, however, may use other types of filters, as desired. For example, one may use FIR, time-varying, non-linear filter circuitries, or complex filter structures. The choice of the type of filter depends on various performance and design criteria, such as magnitude and group delay response, power consumption, use of silicon area, etc., as persons of ordinary skill in the art would understand.

[0220] Note that, unlike conventional circuits, RF receivers or transceivers according to the invention provide channelization filtering within the receiver circuitry itself. Conventional circuits provide channelization filtering as part of the baseband processor circuitry that accompanies the RF circuitry. RF receivers or transceivers according to the invention, however, provide channelization filtering within the receiver digital circuitry. The CIC filter circuitry and the secondary filter circuitry within the receiver digital circuitry perform channelization filtering. In other words, they transmit the desired signal channel while rejecting other users' channels and interfering signals.

[0221] Providing channelization filtering within the RF circuitry reduces the processing load on the baseband processor circuitry. Furthermore, where the baseband processor circuitry accepts analog signals from the RF circuitry, providing channelization filtering within the RF circuitry overcomes the requirement for the DAC circuitries at the output of the RF circuitry to cope with adjacent channel signals. Consequently, one may use cheaper, less complex, or smaller DAC circuitries and/or baseband processor circuitries.

[0222] FIG. 19 provides a conceptual or functional signal flow-diagram of the digital down-converter circuitry **427**. One may use the digital down-converter circuitry of FIG. 19 in the RF apparatus shown in FIGS. 2 and 4-8, as desired. The digital down-converter circuitry **427** includes four multiplier circuitries **1903**, **1906**, **1909**, and **1912**. The digital down-converter circuitry also includes two combiner circuitries **1915** and **1918**. The multiplier circuitries **1903**, **1906**, **1909**, and **1912** perform a fully complex multiplication of the input signals from the receiver analog circuitry (i.e., single-ended versions of the in-phase digital receive signal **421** and the quadrature digital receive signal **424**) with the input signals from the IF LO (i.e., the IF LO in-phase signal **1718** and the IF LO quadrature signal **1721**). Table 4 below lists the input operands to each of the multiplier circuitries **1903**, **1906**, **1909**, and **1912**. Signals **421A** and **424A** represent single-ended versions of the differential one-bit in-phase and quadrature digital receive signals **421** and **424**, respectively.

TABLE 4

Multiplier Circuitry	First Operand	Second Operand
1903	In-phase digital receive signal 421A	IF LO in-phase signal 1718
1906	In-phase digital receive signal 421A	IF LO quadrature signal 1721
1909	Quadrature digital receive signal 424A	IF LO quadrature signal 1721
1912	Quadrature digital receive signal 424A	IF LO in-phase signal 1718

[0223] Combiner circuitry **1915** subtracts the output of multiplier circuitry **1909** from the output of multiplier circuitry **1903** to generate the in-phase output signal of the digital down-converter circuitry **427**. Combiner circuitry **1918** adds together the output signals of multiplier circuitry **1906** and multiplier circuitry **1912** to provide the quadrature output signal of the digital down-converter **427**. Note that this circuit arrangement applies to a signal centered at $+f_{IF}$. For a signal centered at $-f_{IF}$, one may switch around the operands applied to the combiner circuitries **1915** and **1918**.

[0224] Note that the in-phase digital receive signal **421** and the quadrature digital receive signal **424** are one-bit digital signals. In exemplary embodiments of the invention, the in-phase and quadrature digital receive signals **421** and **424** have numerical values of +1 and -1, which map to binary logic zero and one levels. Note that one may assign the numerical values and the corresponding binary logic values to the in-phase and quadrature digital receive signals **421** and **424**, as desired. The IF LO in-phase signal **1718** and the IF LO quadrature signal **1721** are multi-bit digital signals. Consequently, the output signals of the multiplier circuitries **1903**, **1906**, **1909**, and **1912** are multi-bit digital signals.

[0225] As noted above, one of the operands for each of the multiplier circuitries **1903**, **1906**, **1909**, and **1912** constitutes a one-bit digital signal (i.e., the in-phase digital receive signal **421** and quadrature digital receive signal **424**). As a result, the digital down-converter circuitry **427** according to the invention may employ simple circuit arrangements to implement multiplier circuitries **1903**, **1906**, **1909**, and **1912**, rather than full multiplier circuitries. In exemplary embodiments, the multiplier circuitries **1903**, **1906**, **1909**, and **1912** include circuitry that conditionally changes the sign of the other respective operand to multiplier circuitries **1903**, **1906**, **1909**, and **1912** (i.e., the IF LO in-phase signal **1718** and the IF LO quadrature signal **1721**). In other words, in this embodiment, each of the multiplier circuitries **1903**, **1906**, **1909**, and **1912** maps the two logic levels of the in-phase digital receive signal **421** and quadrature digital receive signal **424** to either +1 or -1, respectively, and changes the sign of the IF LO in-phase signal **1718** and the IF LO quadrature signal **1721** accordingly. This implementation results in simplified structures for the digital down-converter circuitry **427** and, thus, hardware, power, and cost savings.

[0226] By using the architectures shown in FIG. 18 rather than the architectures in FIG. 17, one may trade off the simplicity in the digital down-converter circuitry **427** for simplicity in the digital filter circuitry **436**. In other words,

the digital filter circuitries **436** in **FIG. 18** receive one-bit signals **421** and **424** from the receiver analog circuitry. Because the digital filter circuitries **436** operate on one-bit, rather than multiple-bit signals, they may have a simplified architecture and/or structure. The output signals of the digital filter circuitries **436**, however, provide multiple-bit output signals to the digital down-converter circuitries **427**. The digital down-converter circuitries **427** in **FIG. 18** are relatively more complex compared to the digital down-converter circuitries **427** in **FIG. 17**, because they operate on multiple-bit signals. Thus, by using the architectures shown in **FIG. 18**, one trades off the simplicity of the digital down-converter circuitry **427** for simplicity in the digital filter circuitry **436**.

[0227] **FIGS. 20A and 20B** illustrate conceptual or functional block diagrams of IF LO circuitry **1715** according to the invention. **FIG. 20A** shows a conceptual or functional block diagram of one embodiment of an IF LO circuitry **1715** that uses sine and cosine look-up tables. The IF LO circuitry **1715** in **FIG. 20A** includes a sine look-up table **2003A**, a cosine look-up table **2006A**, sign inversion circuitries **2006A** and **2009A**, counter circuitry **2015A**, and selection-logic circuitry **2018A**. The sine look-up table **2003A** includes digital words that correspond to sine values. Similarly, the cosine look-up table **2006A** stores digital words that correspond to cosine values. In response to count value **2021A** from the counter circuitry **2015A**, the sine look-up table **2003A** and the cosine look-up table **2006A** provide sine and cosine values, respectively.

[0228] Exemplary embodiments of the invention use read-only memory (ROM) circuitries (not shown in **FIG. 20A**) to implement the sine look-up table **2003A** and the cosine look-up table **2006A**. A first ROM circuitry stores digital words for the sine values, whereas a second ROM circuitry stores digital words for the cosine values. One, however, may implement the sine look-up table **2003A** and the cosine look-up table **2006A** in a variety of ways, as persons skilled in the art would understand.

[0229] One may provide digital values corresponding to the sine and cosine values with a variety of resolutions (i.e., the number of bits in each output word), as desired. Furthermore, one may use the inventive concepts with other techniques for providing sine and cosine values, as persons of ordinary skill in the art who read the description of the invention will understand. For example, rather than using look-up tables, one may compute sine and cosine values in real time, as desired. As another example, one may use one ROM circuitry to store both sine and cosine values.

[0230] The sine look-up table **2003A** provides its output value (i.e., the sine value) to the selection-logic circuitry **2018A** and the sign inversion circuitry **2009A**. At its output, the sign inversion circuitry **2009A** provides the negative of the sine values. Similarly, the cosine look-up table **2006A** provides cosine values to both the selection-logic circuitry **2018A** and the sign inversion circuitry **2012A**. The sign inversion circuitry **2012A** changes the sign of the cosine value and provides the result (i.e., $-\cos$) to the logic-selection circuitry **2018A**. Thus, the selection-logic circuitry **2018A** receives the following four quantities: \sin , $-\sin$, \cos , and $-\cos$.

[0231] The counter circuitry **2015A** counts through a set of digital numbers. The counter circuitry **2015A** provides its

count value **2021A** to the sine look-up table **2003A** and the cosine look-up table **2006A**. The count value **2021A** serves as a pointer or index to the sine look-up table **2003A** and the cosine look-up table **2006A**. In exemplary embodiments of the invention, the sine look-up table **2003A** and the cosine look-up table **2006A** use the count value **2021A** as an address input in their respective ROM circuitries in order to retrieve the sine and cosine values.

[0232] The counter circuitry **2015A** also provides the count value **2021A** to the selection-logic circuitry **2018A**. The count value **2021A** signifies the quadrant for which the selection-logic circuitry **2018A** provides output signals. The selection-logic circuitry **2018A** uses the count value **2021A** and the quantities it receives from sine look-up table **2003A**, the cosine look-up table **2006A**, sign inversion circuitry **2009A**, and sign inversion circuitry **2012A** (i.e., \sin , $-\sin$, \cos , and $-\cos$, respectively) to generate the IF LO in-phase signal **1718** and the IF LO quadrature signal **1721**.

[0233] In exemplary embodiments of the invention, the logic-selection circuitry **2018A** includes a multiplexer circuitry (not shown explicitly) to select from the input signals of the logic-selection circuitry **2018A**. The logic-selection circuitry **2018A** uses the count value **2021A** to select from the input terms (i.e., \sin , $-\sin$, \cos , and $-\cos$), and provide the selected terms as IF LO in-phase signal **1718** and IF LO quadrature signal **1721** signal. By using the circuit arrangement shown in **FIG. 20A** in exemplary embodiments, one may reduce the size of the look-up tables **2003A** and **2006A** by taking advantage of the symmetries in the sine and cosine functions. In other words, the look-up tables **2003A** and **2006A** may store one-fourth of the waveforms for sine and cosine functions and use the symmetry in those functions to derive values for other portions of the waveforms.

[0234] Note that **FIG. 20A** shows one possible arrangement for the IF LO circuitry **1715**. As persons of ordinary skill in the art who read the disclosure of the invention will understand, however, one may use a variety of arrangements and implementations for the IF LO circuitry **1715**, as desired. For example, **FIGS. 19 and 20A** show conceptual block diagrams of the digital down-converter circuitry **427** and the IF LO circuitry **1715** as separate blocks of circuitry. One, however, may combine the functionality of the digital down-converter circuitry **427** and the IF LO circuitry **1715** into one block, as desired.

[0235] **FIG. 20B** shows a conceptual or functional block diagram of a circuit arrangement that combines the functionality of the IF LO circuitry **1715** with the functionality of the digital down-converter **427**. The circuit arrangement in **FIG. 20B** includes a $(\sin+\cos)$ look-up table **2003B**, a $(\sin-\cos)$ look-up table **2006B**, sign inversion circuitries **2006B** and **2009B**, counter circuitry **2015B**, and selection-logic circuitry **2018B**. The $(\sin+\cos)$ look-up table **2003B** includes digital words that correspond to sine plus cosine values. Similarly, the $(\sin-\cos)$ look-up table **2006B** stores digital words that correspond to sine minus cosine values. In response to the count value **2021B** from the counter circuitry **2015B**, the $(\sin+\cos)$ look-up table **2003B** and the $(\sin-\cos)$ look-up table **2006B** provide $(\sin+\cos)$ and $(\sin-\cos)$ values, respectively.

[0236] Exemplary embodiments of the invention use read-only memory (ROM) circuitries (not shown in **FIG. 20B**) to implement the $(\sin+\cos)$ look-up table **2003B** and the $(\sin-$

cos) look-up table **2006B**. A first ROM circuitry stores digital words for the sine plus cosine values, whereas a second ROM circuitry stores digital words for the sine minus cosine values. One, however, may implement the (sin+cos) look-up table **2003B** and the (sin-cos) look-up table **2006B** in a variety of ways, as persons skilled in the art would understand. In exemplary embodiments of the invention, the (sin+cos) look-up table **2003B** and the (sin-cos) look-up table **2006B** provide 19-bit digital values as their respective outputs. One, however, may choose to provide digital values with other resolutions, as desired, by making modifications that persons skilled in the art would understand.

[0237] Moreover, by using the circuit arrangement shown in **FIG. 20B** in exemplary embodiments, one may reduce the size of the look-up tables **2003B** and **2006B** by taking advantage of the symmetries in the sine and cosine functions. In other words, the look-up tables **2003B** and **2006B** may store one-fourth of the waveforms for the (sin+cos) and (sin-cos) functions and use the symmetry properties of sine and cosine functions to derive values for other portions of the waveforms. Furthermore, note that one may use the inventive concepts with other techniques for providing sine and cosine values, as persons of ordinary skill in the art who read the description of the invention will understand. For example, rather than using look-up tables, one may compute sine and cosine values and, hence, (sin+cos) and the (sin-cos) values, in real time, as desired.

[0238] The (sin+cos) look-up table **2003B** provides its output value (i.e., the sine plus cosine value) to the selection-logic circuitry **2018B** and the sign inversion circuitry **2009B**. At its output, the sign inversion circuitry **2009B** provides the negative of sine plus cosine, or $-(\text{sin}+\text{cos})$. Similarly, the (sin-cos) look-up table **2006B** provides sine minus cosine values to both the selection-logic circuitry **2018B** and the sign inversion circuitry **2012B**. The sign inversion circuitry **2012B** changes the sign of the sine minus cosine value and provides the result (i.e., $-(\text{sin}-\text{cos})$) to the logic-selection circuitry **2018B**. Thus, the selection-logic circuitry **2018B** receives the following four quantities: (sin+cos), $-(\text{sin}+\text{cos})$, (sin-cos), and $-(\text{sin}-\text{cos})$.

[0239] The counter circuitry **2015B** counts through a set of digital numbers. The counter circuitry **2015B** provides its count value **2021B** to the (sin+cos) look-up table **2003B** and the (sin-cos) look-up table **2006B**. The count value **2021B** serves as a pointer or index to the (sin+cos) look-up table **2003B** and the (sin-cos) look-up table **2006B**. In exemplary embodiments of the invention, the (sin+cos) look-up table **2003B** and the (sin-cos) look-up table **2006B** use the count value **2021B** as an address input in their respective ROM circuitries in order to retrieve the (sin+cos) and (sin-cos) values.

[0240] The counter circuitry **2015B** also provides the count value **2021B** to the selection-logic circuitry **2018B**. The selection-logic circuitry **2018B** uses the count value **2021B** (i.e., quadrant information) and the quantities it receives from (sin+cos) look-up table **2003B**, the (sin-cos) look-up table **2006B**, sign inversion circuitry **2009B**, and sign inversion circuitry **2012B** (i.e., (sin+cos), $-(\text{sin}+\text{cos})$, (sin-cos), and $-(\text{sin}-\text{cos})$, respectively) to generate the in-phase and quadrature output signals. In addition, the selection-logic circuitry **2018B** uses in-phase digital receive

signal **421A** and quadrature digital receive signal **424A** to generate its in-phase and quadrature output signals.

[0241] The circuit arrangement shown in **FIG. 20B** incorporates into the logic-selection circuitry **2018B** the multipliers (e.g., multiplier circuitries **1903**, **1906**, **1909**, and **1912** in **FIG. 19**) that one would use if one were to implement a separate digital down-converter circuitry **427**. Furthermore, using the circuit arrangement in **FIG. 20B** uses stored (sin+cos) and (sin-cos) values in order to implement the function of adders in the digital down-converter circuitry (e.g., adder circuitries **1915** and **1918** in **FIG. 19**).

[0242] Note that **FIG. 20B** shows one possible arrangement for the combined functionality of the IF LO circuitry **1715** and the digital down-converter circuitry **427**. As persons of ordinary skill in the art who read the disclosure of the invention will understand, however, one may use a variety of arrangements and implementations, as desired.

[0243] The signal processing blocks within the digital filter circuitry **436** use as building blocks digital integrator circuitries and digital differentiator circuitries. **FIGS. 21** and **22** show a digital integrator circuitry **2100** and a digital differentiator circuitry **2200**, respectively, for use in exemplary embodiments of the invention.

[0244] The digital integrator circuitry **2100** in **FIG. 21** includes a delay (or z^{-1} block) circuitry **2103** and combiner circuitry **2106**. The delay circuitry **2103** generates a delayed version of the output signal $y_i(n)$ and provides the delayed signal to the combiner circuitry **2106**. The combiner circuitry **2106** sums the input signal $x_i(n)$ with the delayed version of the output signal $y_i(n)$. The output signal of the combiner circuitry **2106** defines the output signal $y_i(n)$ of the digital integrator circuitry **2100**. The digital integrator circuitry **2100** has the following transfer function, $H_i(D)$:

$$H_i(D) = \frac{1}{1-D}$$

[0245] Referring to **FIG. 22**, the digital differentiator circuitry **2200** has a delay circuitry **2203** that generates a delayed version of the input signal, $x_d(n)$. The delay circuitry **2203** provides the delayed input signal to combiner circuitry **2206**. The combiner circuitry **2206** subtracts the delayed version of the input signal $x_d(n)$ from the input signal $x_d(n)$. The output signal of the combiner circuitry **2206** defines the output signal $y_d(n)$ of the digital differentiator circuitry **2200**. The digital differentiator circuitry **2200** has the transfer function:

$$H_d(D) = 1-D.$$

[0246] **FIG. 23** shows a conceptual or functional block diagram of a CIC filter circuitry for use in exemplary embodiments of the invention. The CIC filter circuitry includes combiner circuitry **2303**, delay circuitry **2306**, decimator circuitry **2309**, combiner circuitry **2315**, and delay circuitry **2312**. The decimator circuitry **2309** represents a circuit that decimates its input data by is N. One may implement the decimator circuitry **2309** as a delay element (such as a flip-flop) clocked at a frequency of 1/N of the sampling frequency of its input signal. In the exemplary embodiment shown in **FIG. 23**, the decimator circuitry **2309**

decimates its input data by 16 (i.e., N=16) although, generally, one may use other values of N, as desired.

[0247] Note that combiner circuitry 2303 and delay circuitry 2306 together provide an integrator circuitry (see FIG. 21). Likewise, note that the delay circuitry 2312 and combiner circuitry 2315 together make a differentiator circuitry (see FIG. 22). Thus, the CIC filter circuitry in FIG. 23 effectively includes a cascade of an integrator circuitry, a decimator circuitry 2309, and a differentiator circuitry.

[0248] The CIC filter circuitry has the following impulse response at a sampling frequency that equals the input sampling frequency (i.e., 13 MHz in exemplary embodiments):

$$0, 0, 0, 1, 1, 1, 1, 1, 1, 1, 1, 1, 1, 1, 1, 1, 1, 1, 1, 1, 0, 0, 0, \dots$$

↑
Time=0

[0249] Note that the above impulse response represents the impulse response viewed at the input clock rate, rather than at the output clock rate. Thus, the impulse response of the CIC filter circuitry has the shape of a rectangular window in the time domain. The number of “1”s in the impulse response equals the decimation factor. In exemplary embodiments, the decimation factor equals 16. One, however, may use other values of decimation factors, as desired. The rectangular impulse response in the time domain corresponds to a sinc function in the frequency domain.

[0250] As persons skilled in the art would appreciate, the CIC filter circuitry has a transfer function:

$$H_{CIC}(D)=\frac{1+D+D^2+D^3+D^4+D^5+D^6+D^7+D^8+D^9+D^{10}+D^{11}+D^{12}+D^{13}+D^{14}+D^{15}}{D^{16}}$$

[0251] Note that the CIC filter circuitry in FIG. 23 includes feedback (through delay circuitry 2306 in the integrator circuitry), so it appears to constitute an infinite-impulse response circuit. Because of pole-zero cancellation, however, the CIC filter circuitry behaves (from an input-output point of view) as a finite-impulse response circuit.

[0252] FIG. 24 illustrates a conceptual or functional block diagram of a boxcar filter circuitry that one may use in exemplary embodiments of the invention. The boxcar filter circuitry includes a cascade of delay circuitries 2403A-2403O. An input signal drives the first delay circuitry 2403A. The boxcar filter circuitry also includes a cascade of combiner circuitries 2406A-2406O. The input signal also drives one input of the first combiner circuitry 2406A. The output signal of delay circuitry 2403A drives another input of the first combiner circuitry 2406A. Each of the succeeding combiner circuitries 2406B-2406O receives one of its input signals from the output of the preceding combiner circuitry. Each of the succeeding combiner circuitries 2406B-2406O in the chain also receives a second input from a corresponding delay circuitry 2403B-2403O. For example, combiner circuitry 2406B receives one operand from the output of combiner circuitry 2406A and another operand from the output of delay circuitry 2403B, and so on.

[0253] The output of the last combiner circuitry, i.e., combiner circuitry 2406O, drives a decimator circuitry 2409. The decimator circuitry 2409 generally decimates by a

factor N. In exemplary embodiments of the invention, N equals 16, although one may generally use other values of N, as desired. Note that the boxcar filter circuitry in FIG. 24 includes 15 delay circuitries 2403A-2403O and 15 combiner circuitries 2406A-2406O. Depending on a given set of specifications and targeted performance, however, one may use other numbers of delay and combiner circuitries, as desired.

[0254] The boxcar filter circuitry in FIG. 24 has the same impulse response and transfer function as does the CIC filter circuitry in FIG. 23. From a hardware realization point of view, however, the CIC filter circuitry provides a more efficient arrangement. The CIC filter circuitry uses two combiner circuitries and three registers (to implement the delay circuitries), whereas the boxcar filter circuitry uses 15 combiner circuitries and 16 registers. One may use either the CIC filter circuitry or the boxcar filter circuitry to implement embodiments of the invention, depending on desired performance and specifications, as persons skilled in the art would understand.

[0255] FIG. 25 shows a conceptual or functional block diagram of a sixth-order CIC filter circuitry for use in the receiver digital circuitry in exemplary embodiment of the invention. The CIC filter circuitry includes a cascade of an integrator chain section, a decimator circuitry 2509, and a differentiator chain section (the differentiator chain section constitutes a comb filter circuitry). The CIC filter circuitry in FIG. 25 has a similar signal-flow architecture to the CIC filter circuitry in FIG. 23. Note, however, that the CIC filter circuitry in FIG. 25 uses sixth-order integrator and differentiator chain sections, whereas the CIC filter circuitry of FIG. 23 uses first-order integrators and differentiators. Depending on a given set of specifications and performance targets, one may use other numbers of integrators and differentiators, as desired. The 6th-order integrator and differentiator chain sections corresponds to a transfer function in the frequency domain that constitutes a sinc function raised to the sixth power.

[0256] The integrator chain section includes a cascade of six integrator circuitries (each similar to the integrator circuitry in FIG. 21) that use combiner circuitries 2503A-2503F and delay circuitries 2506A-2506F. The output of the integrator chain section drives the decimator circuitry 2509. The decimator circuitry 2509 generally decimates by a factor of N. In exemplary embodiments of the invention, N equals 16, although one may generally use other values of N, as desired.

[0257] The differentiator chain includes a cascade of six differentiator circuitries (each similar to the differentiator circuitry in FIG. 22) that use combiner circuitries 2512A-2512F and delay circuitries 2515A-2515F. Each combiner circuitry 2512A-2512F subtracts the output signal of a corresponding delay circuitry 2515A-2515F from the output signal of the preceding stage. The output of the differentiator chain section (i.e., the output of combiner circuitry 2512F) constitutes the output signal of the CIC filter circuitry.

[0258] As FIGS. 17 and 18 illustrate, the output of the CIC filter circuitry in each of the in-phase and quadrature signal paths drives a secondary filter circuitry, such as an IIR filter circuitry. In exemplary embodiments, the IIR filter circuitry includes a cascade of one or more second-order, or biquad, filter circuitries and a notch filter circuitry. Each of the biquad filter circuitries and the notch filter circuitry

constitutes a second-order filter. Note that the IIR filter circuitries and, more generally, the secondary filter circuitries, follow the CIC filter circuitries and, hence, the decimator circuitry. Thus, the IIR filter circuitries or secondary filter circuitries operate at a lower sample rate than the sample rate of the input signals to the CIC filter circuitries (13 MHz in exemplary embodiments of the invention). Operation at a lower sample rate results in less stringent hardware specifications and less power consumption, for example, in CMOS implementations of the invention. In exemplary embodiments of the invention, the IIR filter circuitries or secondary filter circuitries operate at a sample rate of 812.5 kHz, although one may use other clock rate and sample rate arrangements, as desired.

[0259] FIG. 26 shows a conceptual or functional block diagram of a biquad filter circuitry for use in exemplary embodiments of the invention. The biquad filter circuitry includes five gain circuitries 2603A-2603E, three combiner circuitries 2606A-2606C, and two delay circuitries 2609A-2609B. Gain circuitries 2603A-2603C have gain values (or coefficients) of b_0 , b_1 , and b_2 , respectively. Similarly, gain circuitries 2603D-2603E have gain values of $-a_1$ and $-a_2$, respectively. Note that delay circuitries 2609A-2609B operate at the sample rate of the biquad filter circuitry, i.e., 812.5 kHz in exemplary embodiments of the invention.

[0260] Gain circuitry 2603C scales the input signal by b_2 and provides the result to combiner circuitry 2606C. Combiner circuitry 2606C also receives as a second input signal the output signal (i.e., the output signal of the combiner circuitry 2606A), scaled by $-a_2$ by gain circuitry 2603E. Combiner circuitry 2606C provides the sum of its two input signals to delay circuitry 2609B. Combiner circuitry 2606B receives one input from delay circuitry 2609B. Two other inputs to combiner circuitry 2606B constitute the input signal scaled by b_1 (provided by gain circuitry 2603B), and the output signal scaled by $-a_1$ (provided by gain circuitry 2603D), respectively. Combiner circuitry 2606B sums its three input signals and provides the resulting quantity to delay circuitry 2609A. Combiner circuitry 2606A provides the output signal of the biquad filter circuitry by summing together the output signal of delay circuitry 2609A and a version of the input signal scaled by b_0 (provided by gain circuitry 2603A).

[0261] The overall biquad filter circuitry has the following transfer function:

$$H_B(D) = \frac{b_0 + b_1D + b_2D^2}{1 + a_1D + a_2D^2}.$$

[0262] As the above transfer function indicates, the biquad filter circuitry has two zeros and two poles. The values of b_0 , b_1 , and b_2 control the location of the zeros of the biquad filter circuitry, whereas the values of a_1 and a_2 control its pole locations.

[0263] FIG. 27 depicts a conceptual or functional block diagram of a notch filter circuitry for use in exemplary embodiments of the invention. The notch filter circuitry has a similar signal-flow architecture to the signal-flow architecture of the biquad filter circuitry in FIG. 26. The notch filter circuitry includes five gain circuitries 2703A-2703E,

three combiner circuitries 2706A-2706C, and two delay circuitries 2709A-2709B. Gain circuitries 2703A-2703C have gain values of b_{01} , b_{11} , and b_{21} , respectively. Gain circuitry 2703D has a gain value of $-a_{11}$, and gain circuitry 2703E has a gain value of $1-k$. Gain circuitry 2703E controls some of the characteristics of the notch filter circuitry, as described below in more detail.

[0264] Gain circuitry 2703C scales the input signal by b_2 , and provides the result to combiner circuitry 2706C. A version of the output signal, scaled by $1-k$ by gain circuitry 2703E, constitutes a second input to combiner circuitry 2706C. Combiner circuitry 2706C provides the sum of its input signals to delay circuitry 2709B. Combiner circuitry 2706B receives one input from delay circuitry 2709B. Two additional inputs to combiner circuitry 2706B constitute, respectively, the input signal scaled by b_1 , (provided by gain circuitry 2703B), and the output signal of gain circuitry 2703E (i.e., the output signal of the notch filter circuitry scaled by $1-k$) scaled by $-a_{11}$ (provided by gain circuitry 2703D). Combiner circuitry 2706B sums its three input signals and provides the resulting quantity to delay circuitry 2709A. Combiner circuitry 2706A provides the output signal of the notch filter circuitry by summing together the output signal of delay circuitry 2709A, and the input signal scaled by b_0 , (provided by gain circuitry 2703A), respectively.

[0265] As noted above, in exemplary embodiments, the secondary filter circuitries or IIR filter circuitries in FIGS. 17 and 18 use cascade arrangements of biquad and notch filter circuitries. FIGS. 28A and 28B illustrates examples of such cascade arrangements. As persons of ordinary skill in the art who read the description of the invention will understand, depending on design and performance specifications, one may use either arrangement, as desired. The arrangement in FIG. 28A includes one biquad filter circuitry and one notch filter circuitry. The biquad filter circuitry appears before the notch filter circuitry. The arrangement in FIG. 28B also includes one biquad filter circuitry and one notch filter circuitry. Unlike the arrangement in FIG. 28A, however, the notch filter circuitry in the arrangement in FIG. 28B appears before the biquad filter circuitry.

[0266] The biquad and notch filter circuitries may constitute the biquad filter circuitry and the notch filter circuitry that FIGS. 26 and 27 depict, respectively. The arrangements in FIGS. 28A and 28B are fourth-order filter circuitries overall. One, however, may use a different number of filter circuitries to provide a desired overall order for the filter circuitry, as FIG. 29 and its description below illustrate.

[0267] One may implement the biquad and notch filter circuitries using a variety of digital filter hardware realization techniques, as persons of ordinary skill in the art would understand. For example, one may use dedicated hardware, finite-state machines, standard cells, programmable hardware (e.g., PLDs, CPLDs, or FPGAs), or a combination of hardware and software, as desired.

[0268] Exemplary embodiments of the invention realize the biquad filter circuitry and the notch filter circuitry using DSP engines. The DSP engines constitute custom hardware, designed to perform a relatively limited set of signal processing operations. A control logic circuitry includes hardwired, pre-selected operations. Depending on the design and performance specifications for a particular implementation,

however, one may use other arrangements, such as signal processing hardware with programmable operations, as desired. The choice of the signal processing hardware for a particular implementation falls within the knowledge of persons skilled in the art who read the description of the invention.

[0269] The DSP engines have multiply and add capabilities, together with a set of registers for storing operands and the results of calculations. The DSP engines use a clock frequency that is a multiple (16 in exemplary embodiments) of the filter circuitries' data sample rate. For example, in some embodiments, the DSP engines use a 13 MHz clock, whereas the filter circuitries have an 812.5 kHz clock, although one may use other clocking arrangements, as desired. Using different clocking rates for the DSP engines and the filter circuitries allows time-multiplexing the multiply and add operations used to realize the filter circuitries.

[0270] In exemplary embodiments of the invention, each DSP engine can implement the functionality of two biquad filter circuitries, or one biquad filter circuitry and one notch filter circuitry, and the programmable-gain circuitries for both the in-phase and quadrature signal paths. Note, however, that one may implement different numbers of filter circuitries by each DSP engine, as desired. Exemplary embodiments of the invention use three DSP engines, thus providing the capability for filter circuitries up to 12th order. Note, however, that one may use different numbers and/or types of DSP engines to realize other filter orders, as desired, by making modifications that persons of ordinary skill in the art understand.

[0271] DSP engines in exemplary embodiments of the invention use coefficient values stored in ROM circuitries. In those embodiments, one may change the coefficient values by modifying the contents of the ROM circuitries. Note, however, that one may implement and/or store the coefficient values in a variety of ways, as persons skilled in the art would understand. For example, one may store the coefficient values in register circuitries that an accompanying baseband processor circuitry programs. As another example, one may store the coefficient values in erasable programmable ROM (EPROM), electrically erasable programmable ROM (EEPROM), or electrically erasable ROM (EEROM) circuitries, or flash memory circuitries, as desired.

[0272] One may use coefficient values and state variables with a desired bit precision in the digital filter circuitry. Exemplary embodiments of the invention use bit precisions that tend to reduce quantization noise in typical applications. In those embodiments, the state variables each include 26 bits. Filter coefficients, with the exception of b_0 and b_{01} in FIGS. 26-28, use a simple floating-point representation, with a 12-bit mantissa and a 3-bit exponent.

[0273] Coefficients b_0 and b_{01} , result from simple shift operations on the input data, $x(n)$, of the biquad filter circuitry and the notch filter circuitry, respectively. In other words, to realize coefficients b_0 and b_{01} the hardware shifts the input data corresponding to $x(n)$. As persons of ordinary skill in the art understand, a right-shift operation corresponds to a divide-by-two operation. Thus, by using N right-shift operations, one may in effect multiply the input samples $x(n)$ by $\frac{1}{2}N$. Conversely, by using M left-shift operations, one may multiply the input samples by 2^M . Using the shift operations to realize multiplication or division by

powers of 2, rather than using a full multiplier, provides hardware savings and circuit simplification in exemplary embodiments of the invention. Note, however, that one may use multipliers in order to implement arbitrary filter coefficients b_0 and b_{01} , as desired. Because the shift operations do not use a multiplier circuitry in the DSP engines, one may use the multiplier circuitry to implement the functionality of PGA circuitries 836A and 836B.

[0274] In exemplary embodiments, coefficient b_{11} has a 19-bit mantissa and a 3-bit exponent. The increased bit precision of the mantissa tends to allow more precise positioning of the notch filter circuitry's notch frequency. The desired precision of the various coefficients may vary, depending on design and specification factors for each particular embodiment of the invention. One may therefore use other precisions and arrangements of the various coefficients, as desired.

[0275] FIGS. 29A-29F show exemplary arrangements of biquad filter circuitries and notch filter circuitries to provide various desired overall order for the secondary filter circuitry. The overall order of the filter circuitry influences the characteristics of the filter circuitry, such as its magnitude response and group-delay characteristics, as persons of ordinary skill in the art would understand.

[0276] FIGS. 29A-29C illustrate a cascade arrangement of biquad and notch sections where the notch section appears after the biquad sections. FIG. 29A illustrates a cascade arrangement of two biquad filter circuitries and a notch filter circuitry. The overall filter circuitry constitutes a 6th-order filter. FIG. 29B depicts a similar arrangement. The cascade arrangement in FIG. 29B includes three biquad filter circuitries and a notch filter circuitry. Thus, the overall filter circuitry is an 8th-order filter. FIG. 29C shows a cascade arrangement of five biquad filter circuitries and a notch filter circuitry. The overall cascade arrangement constitutes a 12th-order filter.

[0277] FIGS. 29D-29F illustrate a cascade arrangement of notch and biquad sections where the notch section appears before the biquad sections. Placing the notch filter circuitry before the biquad filter circuitries may lead to a quicker settling time when used in combination with the adjustment of the notch filter circuitry, described below in detail. FIG. 29D illustrates a cascade arrangement of a notch filter circuitry and two biquad filter circuitries. The overall filter circuitry constitutes a 6th-order filter. FIG. 29E depicts a similar arrangement, where the cascade arrangement includes a notch filter circuitry and three biquad filter circuitries. Thus, the overall filter circuitry is an 8th-order filter. FIG. 29F shows a cascade arrangement of a notch filter circuitry and five biquad filter circuitries. The overall cascade arrangement constitutes a 12th-order filter.

[0278] Note that FIG. 29 illustrates filter circuitry arrangements in exemplary embodiments of the invention. One, however, may use other arrangements that use different numbers of biquad and notch filter circuitries, as desired, depending on various design and performance criteria, as persons skilled in the art would understand. For example, one may use different numbers of biquad filter circuitries and/or different numbers of notch filter circuitries, as desired. Furthermore, one may reverse the order of the biquad section (or sections) and the notch section. In other words, the notch section may appear between two biquad sections, as desired. As one example, the notch filter in

FIGS. 29A and 29D may appear between the two biquad sections, rather than either before them (as in FIG. 29D) or after them (as in FIG. 29A).

[0279] Tables 5-7 provides the values of filter circuitry coefficients for various exemplary embodiments of the invention, as shown in FIGS. 29D-29F. The "Block" column refers to the position of a block within FIG. 29. For example, "Biquad 1" refers to the first biquad section in FIGS. 29D-29F. Table 5 below lists the various coefficient values for the filter circuitry arrangement of FIG. 29D:

TABLE 5

Block	Coefficient	Value
Notch	b ₀₁	1/2
	b ₁₁	-93795/131072
	b ₂₁	1/2
	a ₁₁	-(1559/1024)*(15/16)
	1-k	15/16
Biquad 1	b ₀	1/16
	b ₁	1204/65536
	b ₂	4092/65536
	a ₁	-4880/4096
	a ₂	1483/4096
Biquad 2	b ₀	1/4
	b ₁	-53920/65536
	b ₂	45248/65536
	a ₁	-5704/4096
	a ₂	2552/4096

[0280] Table 6 lists the various coefficient values for the filter circuitry arrangement of FIG. 29E:

TABLE 6

Block	Coefficient	Value
Notch	b ₀₁	1/2
	b ₁₁	-93795/131072
	b ₂₁	1/2
	a ₁₁	-(1563/1024)*(15/16)
	1-k	15/16
Biquad 1	b ₀	1/32
	b ₁	3210/65536
	b ₂	1995/65536
	a ₁	-2786/2048
	a ₂	1095/2048
Biquad 2	b ₀	1/2
	b ₁	-86208/65536
	b ₂	59744/65536
	a ₁	-2752/2048
	a ₂	1403/2048
Biquad 3	b ₀	1/8
	b ₁	3434/65536
	b ₂	7692/65536
	a ₁	-2956/2048
	a ₂	1123/2048

[0281] Finally, Table 7 lists the coefficient values for the filter circuitry arrangement shown in FIG. 29F:

TABLE 7

Block	Coefficient	Value
Notch	b ₀₁	1/2
	b ₁₁	-93795/131072
	b ₂₁	1/2
	a ₁₁	-(1526/1024)*(15/16)
	1-k	15/16

TABLE 7-continued

Block	Coefficient	Value
Biquad 1	b ₀	1/32
	b ₁	1443/65536
	b ₂	1937/65536
	a ₁	-3198/2048
	a ₂	1660/2048
Biquad 2	b ₀	1/8
	b ₁	-4640/65536
	b ₂	7372/65536
	a ₁	-2986/2048
	a ₂	1088/2048
Biquad 3	b ₀	1/2
	b ₁	-75072/65536
	b ₂	48064/65536
	a ₁	-3144/2048
	a ₂	1246/2048
Biquad 4	b ₀	1/2
	b ₁	-89920/65536
	b ₂	61664/65536
	a ₁	-3198/2048
	a ₂	1396/2048
Biquad 5	b ₀	1/4
	b ₁	-6640/65536
	b ₂	14848/65536
	a ₁	-2950/2048
	a ₂	1683/2048

[0282] FIG. 30 illustrates various characteristics of an 8th-order filter circuitry arrangement, such as the filter circuitry shown in FIG. 29E. The filter circuitry includes three biquad sections and one notch section, thus providing an 8th-order overall transfer function. FIG. 30A depicts a pole-zero map in the z-plane. The pole-zero map includes eight zeros, grouped as zero pairs 3003A-3003B, 3006A-3006B, 3009A-3009B, and 3012A-3012B. The pole-zero map also shows eight poles, grouped as pole pairs 3015A-3015B, 3018A-3018B, 3021A-3021B, 3024A-3024B. The paired zeros and poles indicate that the filter circuitry has a real transfer function.

[0283] FIG. 30B illustrates a single-sided magnitude response (i.e., symmetrical around zero frequency, or DC) of the 8th-order filter circuitry. FIG. 30B includes four plots, each corresponding to the cumulative input-output magnitude response of the blocks in FIG. 29E. In other words, plots 3030A, 3030B, 3030C, and 3030D provide the magnitude responses between the input to the notch section and the outputs of the notch section, the first biquad section, the second biquad section, and the third biquad section, respectively, of the embodiment shown in FIG. 29E. Hence, plot 3030D corresponds to the transfer function from the input of the notch section to the output of the last biquad section. As plot 3030D shows, the filter circuitry provides a low-pass transfer function. Furthermore, the notch section provides a notch at 100 kHz.

[0284] Note that the circuit arrangements in FIG. 29 contemplate a real filter circuitry for the in-phase signal-path and a real filter circuitry for the quadrature signal-path. Consequently, the overall filter circuitry constitutes a real filter that has symmetrical characteristics (around DC or zero frequency) in the frequency domain.

[0285] FIG. 30C shows the group delay response of the 8th-order filter circuitry. FIG. 30C includes four plots, each corresponding to the cumulative group delay of the blocks in FIG. 29E. Thus, plots 3040A, 3040B, 3040C, and 3040D

provide the group delay responses between the input to the notch section and the outputs of the notch section, the first biquad section, the second biquad section, and the third biquad section, respectively, of the embodiment shown in FIG. 29E. Accordingly, plot 3040D corresponds to the group delay from the input of the notch section to the output of the last biquad section.

[0286] One may use different bit precisions for the digital signals in various embodiments of the invention, as desired. In one exemplary embodiment of the invention, the IF LO in-phase signal 1718 and the IF LO quadrature signal 1721 each contain 18 bits, and the output signals of the multiplier circuitries 1903, 1906, 1909, and 1912 each include 18 bits. The output signals 1730A-1730B of the digital down-converter circuitry 427 each have 19 bits of resolution. The secondary filter circuitry 1710A-1710B (IIR-type filters) use 26-bit state variables and have 26-bit output signals 1740A-1740B, and the PGA circuitries 836A-836B have 10-bit output signals 869, 872. Furthermore, the CIC circuitries 1705A-1705B use 6th-order integrator and differentiator chain sections, as shown in FIG. 25. The integrator chain section uses different bit precisions for each of the integrator circuitries within the chain. Table 8 below describes the bit precisions for the loop signal and the output signal of each of the six integrator circuitries:

TABLE 8

Integrator No.	Loop Signal	Output Signal
1	43 bits	39 bits
2	39 bits	35 bits
3	35 bits	31 bits
4	31 bits	27 bits
5	27 bits	23 bits
6	23 bits	18 bits

[0287] The differentiator circuitries in the differentiator chain section use 18-bit signals and has 18-bit output signals (i.e., the CIC circuitries 1705A-1705B have 18-bit output signals 1735A-1735B).

[0288] Note, however, that, rather than using the above bit precisions, one may use other number of bits to provide signals with various resolutions, as desired, by making modifications that persons of ordinary skill in the art would understand. Furthermore, generally, the signals in exemplary embodiments of the invention use two's complement signed number notation. One, however, may use other number representation formats, as desired, by making modifications that artisans who read the description of the invention will understand.

[0289] The notch filter circuitry within the digital filter circuitry 437 operates to remove residual DC offsets from the signal of interest. As noted above, the removal of the residual DC offsets according to the invention operates in the presence of interference signals (e.g., interferers and blockers) and the desired signal. Because of circuit non-idealities and non-ideal circuit behavior, DC offsets appear within, and at the outputs of, the receiver analog circuitry. The receiver analog circuitry includes DC offset reduction or cancellation circuitry, as described in co-pending, commonly owned patent application Ser. No. _____, Attorney Docket No. SILA:098, titled "DC Offset Reduction in Radio-Frequency Apparatus and Associated Methods." Some residual DC

offsets, however, may appear at the outputs of the receiver analog circuitry and therefore enter the receiver digital circuitry. The signal processing in the receiver digital circuitry, for example, as shown in FIG. 17, translates or shifts the DC offsets to a frequency of -100 kHz. The notch filter provides a notch at -100 kHz, thus removing any residual DC offsets, as described below in detail.

[0290] Because RF apparatus according to the invention use a relatively low IF frequency (100 kHz in exemplary embodiments), the low-pass filtering by the low-pass sections of the digital filter circuitry (i.e., the circuitry besides the notch filter circuitry) by themselves would not easily remove the DC offsets. A low-pass filter circuitry for removing the residual DC offset would typically have a high order, require more signal processing (thus, more hardware or longer processing time, and/or higher power consumption), and have long transient-response characteristics. A long transient-response characteristic would lead to the receiver digital circuitry having to power up long before the beginning of the reception of a burst of data.

[0291] The notch filter circuitry in exemplary embodiments constitutes a 2nd-order filter that provides a relatively narrow and relatively deep notch at -100 kHz. The notch filter circuitry removes the -100 kHz signal, thus canceling or reducing the effects of any residual DC offsets that enter the receiver digital circuitry. Moreover, the notch filter circuitry can adjust the location of its poles, which tends to reduce its settling time. The reduced settling time allows the receiver digital circuitry to power up at a later time during the reception phase. Delaying the powering up of the receiver digital circuitry helps to save power in portable or battery-operated applications. The reduced settling time also provides more time for the transmit and receive operations and, thus, higher data transfer rates (for example, when using GPRS techniques).

[0292] The notch filter circuitry removes a tone at -100 kHz, which results from the operation of the digital down-converter circuitry 427. FIGS. 31-35 show the waveforms corresponding to the frequency spectrum of signals at various points in the receiver digital circuitry in exemplary embodiments of the invention, for example, as shown in FIG. 17. FIG. 31 illustrates a spectrum of input signals (i.e., in-phase and quadrature signals) of the receiver digital circuitry. The residual DC offset 3103 appears at DC, or zero frequency. The signal band of interest 3106, centered at the IF frequency, appears to the right of the residual DC offset 3103. Noise and interference spectra 3109 fall below DC and to the right of the signal band of interest 3106. The sampling frequency, f_s , is 13 MHz, with a Nyquist rate of $13/2$ MHz, or 6.5 MHz.

[0293] FIG. 32 depicts the spectrum of the output signals of the digital down-converter circuitry 427. Because of the mixing with the IF LO signals 1718 and 1721 in the digital down-converter circuitry 427, the tone corresponding to the residual DC offset 3103 shifts to -100 kHz. Also because of the mixing within the digital down-converter circuitry 427, the signal band of interest 3106 falls within the band from $-f_{IF}$ to f_{IF} , and centers around DC. The noise and interference spectra 3019 occupy the region below $-f_{IF}$ and above f_{IF} .

[0294] FIG. 33 shows the frequency spectrum of the output signal of the CIC circuitry, such as CIC circuitries 1705A-1705B in FIG. 17. Note that the decimator circuitry, such as decimator circuitry 2509 in FIG. 25, reduces the sampling frequency from f_s to f'_s (from 13 MHz to 812.5 kHz in exemplary embodiments). Accordingly, the Nyquist rate reduces from $f_s/2$ to $f'_s/2$. The residual DC offset 3103 still results in a -100 kHz tone, and the signal band of interest 3106 occupies the region between $-f_{IF}$ to f_{IF} , centered around DC. The CIC filter circuitry reduces the amplitude of the noise and interference spectra 3109, which occupy the region below $-f_{IF}$ and above f_{IF} .

[0295] FIG. 34 shows the spectrum of the signals at the output of the notch filter circuitry. The notch filter circuitry has removed the residual DC offset, thus leaving the signal band of interest 3106 in the region between $-f_{IF}$ and f_{IF} . Note that the noise and interference spectra 3109, which occupy the region below f_{IF} and above f_{IF} , remain. FIG. 35 shows the spectrum of the signals at the output of the final biquad section of the IIR filter circuitry, for example, one of the final biquad sections in FIGS. 29D-F. Note that compared to FIG. 33, the biquad sections of the IIR filter circuitry have attenuated the noise and interference spectra 3109. The signal band of interest 3106, which occupies the range between f_{IF} and f_{IF} , remains.

[0296] The plots presented in FIGS. 31-35 correspond to a receiver digital circuitry (e.g., the architecture shown in FIG. 17) that first down-converts the input signal to the receiver digital circuitry and then uses a notch filter circuitry to remove the tone corresponding to the residual DC offset. One, however, may reverse the order of those operations by using a notch filter circuitry to remove the residual offset at DC before the mixing operation of the digital down-converter circuitry 427. One may use such a signal-flow architecture with a receiver digital circuitry as shown in FIG. 18, as desired.

[0297] The notch filter circuitry in exemplary embodiments constitutes a real filter, and therefore has notches at both -100 kHz and $+100$ kHz, but the residual DC offset translates to a tone at -100 kHz. One may use a complex filter (e.g., a filter that has a notch at -100 kHz), as desired. The choice of the type of filter depends on design and performance considerations, as persons of ordinary skill in the art would understand. In general, however, real filters tend to be easier and simpler to implement than complex filters.

[0298] FIGS. 36 and 37 show, respectively, the characteristics of a real notch filter circuitry and a complex notch filter circuitry for use in RF apparatus according to the invention. FIG. 36A illustrates a typical pole-zero diagram for a 2nd-order real notch filter circuitry. The pole-zero diagram includes two zeros and two poles. The zeros reside on the unit circle. The poles fall inside the unit circle to ensure stability of the filter. The relative closeness of the poles to the unit circle tends to affect the settling time of the notch filter circuitry. FIG. 36B provides a frequency response diagram for the notch filter circuitry of FIG. 36A. The notch filter circuitry has two notches, one at $-f_{IF}$, and another at f_{IF} . The notch filter circuitry substantially transmits signals in the frequency band between $-f_{IF}$ and f_{IF} as well as frequencies outside that range, while substantially attenuating tones at the notch frequency.

[0299] FIG. 37A depicts a typical pole-zero diagram for a complex notch filter circuitry. The pole-zero diagram includes a single zero 3705 and a single pole 3710, rather than the complex-conjugate poles of the real notch filter circuitry of FIG. 36. The zero 3705 resides on the unit circle. The pole 3710 resides inside the unit circle. The location of the pole 3710 within the unit circle tends to affect the settling time of the notch filter circuitry. The zero 3705 has a location given by:

[0300] The pole 3710 has a location given by:

$$z_{zero} = e^{-j2\pi \frac{f_{IF}}{f_s}},$$

$$z_{pole} \approx \alpha e^{-j2\pi \frac{f_{IF}}{f_s}},$$

[0301] where α is a function of k . The angle θ , which denotes the angle between the locations of zero 3705 and pole 3710 and the real axis, has the value:

$$\theta = -2\pi \frac{f_{IF}}{f_s}$$

[0302] Note that the zero 3705 resides on the unit circle. Furthermore, note that the location of the pole 3710 depends on the value of k ($1-k$ constitutes one of the coefficients of the notch filter circuitry, as FIGS. 27 and 28 show). The location of the pole 3710 controls the width of the notch.

[0303] FIG. 37B provides a frequency response diagram for the notch filter circuitry of FIG. 37A. The notch filter circuitry has a single notch at $-f_{IF}$. The notch filter circuitry substantially transmits signals in the frequency bands below and above $-f_{IF}$.

[0304] One may use a number of different topologies and architectures for the notch filter circuitry. FIG. 38 shows one example of an alternative notch filter circuitry 3800. The notch filter circuitry 3800 constitutes a complex notch filter realized by means of a complex band-pass filter circuitry arranged within a feedback loop. All signals within the notch filter circuitry 3800 are complex signals. The notch filter circuitry 3800 includes combiner circuitry 3803, gain circuitry 3806, delay circuitry 3809, combiner circuitry 3812, and gain circuitry 3815.

[0305] Gain circuitry 3815, having a gain value of k , scales the output signal of the notch filter circuitry to provide a scaled output signal. The scaled output signal constitutes one operand for combiner circuitry 3812. Combiner circuitry 3812 provides an output signal to delay circuitry 3809. The output of delay circuitry 3809 feeds an input of gain circuitry 3806. An output of gain circuitry 3806 constitutes another operand for combiner circuitry 3812. Gain circuitry 3806 provides a gain of e

$$e^{-j2\pi \frac{f_{IF}}{f_s}}$$

[0306] The output of delay circuitry 3809 also serves as one operand for combiner circuitry 3803. The input signal of the notch filter circuitry provides a second operand for combiner circuitry 3803. Combiner circuitry 3803 subtracts the output of delay circuitry 3809 from the input signal and provides the result as the output signal of the notch filter circuitry.

[0307] As noted above, one may adjust or modify the characteristics of the notch filter circuitry by, among other things, adjusting the location of its poles. More particularly, adjusting the location of the poles of the notch filter circuitry affects the width of the notch and the settling time of the notch filter circuitry. Ideally, one would use a notch filter circuitry that has both a relatively narrow notch and a relatively fast settling time. The width of the notch and the settling speed of the notch filter circuitry, however, have an inverse relationship. Put another way, placing the poles so as to decrease the width of the notch increases the settling time of the notch filter circuitry, and vice-versa.

[0308] Notch filter circuitry in exemplary embodiments of the invention include provisions for adjusting the width of the notch (also called "gear-shifting") and, hence, the settling time of the notch filter circuitry. Although exemplary embodiments of the invention use adjustable notch filter circuitries, depending on performance and design considerations, one may use notch filter circuitries with fixed pole locations, as desired. The adjustment feature of the notch filter circuitry, however, provides a notch with a programmable or adjustable width and settling speed. The adjustment feature also helps the notch filter circuitry to perform its function of canceling or reducing the residual DC offset in the presence of the desired signal, interference, blockers, sweeping interference (for example, resulting from settling operation of the local oscillator circuitry), sweeping blockers, and quantization noise, while maintaining a relatively fast acquisition. By adjusting the width of the notch, notch filter circuitries in exemplary embodiments of the invention provide a trade-off between noise immunity and acquisition speed and accuracy.

[0309] In exemplary embodiments, the notch filter circuitry has an adjustment cycle during which the location of the poles of the filter circuitry vary. In the beginning of the adjustment cycle, the poles reside relatively close to the origin of the z-plane, thus providing a relatively art wide notch, but a relatively fast settling time. Subsequently in the adjustment cycle, the poles of the notch filter circuitry move progressively away from the origin of the z-plane. The movement of the poles progressively decreases the width of the notch to a relatively narrow notch and less distortion to the in-band signal. At the end of the adjustment cycle, the notch stays relatively narrow.

[0310] In exemplary embodiment, the adjustment cycle of the notch filter circuitry ends before the reception of a data burst by the receiver digital circuitry begins. Note, however, that more generally the adjustment cycle of the notch filter circuitry may not end before the reception of a data burst begins. The adjustment of the width of the notch occurs by modifying the values of k (1-k constitutes one of the coefficients of the notch filter circuitry), In exemplary embodiments, the time instances when the value of k changes are programmable (e.g., through instructions from the baseband processor circuitry). A relatively large initial

value of k provides faster acquisition of the DC offset, albeit with more susceptibility to noise, interference, blockers, and quantization noise. Relatively smaller subsequent values of k provide more noise-resistant, more accurate acquisitions of the DC offset.

[0311] FIG. 39 illustrates the adjustment of the poles of the notch filter circuitry, such as the embodiment shown in FIG. 27, as a function of k. FIG. 39 represents a pole-zero diagram on a z-plane for an adjustable notch filter circuitry in exemplary embodiments of the invention. The notch filter circuitry has two zeros 3903A and 3903B, as well as a pole pair 3906A and 3906B. During the adjustment process, the value of k decreases as a function of time, thus causing the location of the poles 3906A-3906B to change.

[0312] Initially, the pole pair 3906A-3906B resides relatively close to the origin of the unit circle. The initial location of the pole pair 3906A-3906B corresponds to k=¼. As the value of k decreases, pole pair 3906A-3906B moves toward the periphery of the unit circle. In other words, the pole pair 3906A-3906B moves to locations denoted by 3906A1 and 3906B1 as k decreases from ¼ to ⅛. A further decrease in the value of k from ⅛ to ⅙ causes the pole pair 3906A-3906B to migrate to locations 3906A2 and 3906B2.

[0313] As noted above, in explemary embodiments, the times at which the value of k changes are also adjustable. The time instances, however, have default values in those embodiments of the invention. Table 9 below provides the default times and the corresponding values of k:

TABLE 9

Time (µs)	k
0	¼
60	⅛
80	⅙
>80	⅙

[0314] For time values of time larger than about 80 µs until the end of the operation cycle of the notch filter circuitry, the value of k remains at ⅙.

[0315] FIG. 40 depicts a timeline for the adjustment of the notch filter circuitry with respect to several other events within RF apparatus according to the invention. In preparation for the commencement of a data reception burst, the local oscillator circuitry powers up and begins to settle. In FIG. 40, the local oscillator circuitry powers up at t=t₀. At t=t₁, DC offset cancellation or reduction begins in the receiver analog circuitry. DC offset cancellation or reduction in the receiver analog circuitry uses an adjustment technique similar to the adjustment of the notch filter circuitry, as described in detail in patent application Ser. No. _____, Attorney Docket No. SILA:098, titled "DC Offset Reduction in Radio-Frequency Apparatus and Associated Methods," referenced above.

[0316] Subsequently, at t=t₂, adjustment of the notch filter circuitry starts with an initial value of k=¼. As part of the adjustment process, the value of k changes to ⅛ and b/16 at t=t₃ and t=t₄, respectively. At t=t₅, the local oscillator circuitry has settled and the data reception burst starts. Also at t=t₅, the secondary filter circuitry begins to settle. Finally, at t=t₆, output data becomes available to the DAC circuitries

and, subsequently, to the baseband processor circuitry. Note that, rather than providing final output data, one may output intermediate data (i.e., data available before the secondary filter circuitry settles) to the DAC circuitries and the baseband processor circuitry, as desired.

[0317] The description of the invention refers to providing a notch at minus the intermediate frequency, or -100 kHz in exemplary embodiments of the invention. Note that that discussion applies to a receiver digital circuitry that has an architecture similar to the architectures in FIGS. 17A-17B. If one uses an architecture that performs the digital filtering operations (including the notch filtering operation) before the digital down-conversion operation, however, the notch filter circuitry should provide a notch at a correspondingly different frequency. For example, if one chooses to use the alternative architectures shown in FIGS. 18A-18B, the notch filter circuitry should provide a notch at zero frequency, or DC. Because in the alternative architectures in FIG. 18A-18B the notch filter circuitry operates on signals that the digital down-converter circuitry 427 has not yet shifted, the notch filter provides the notch at zero frequency.

[0318] Referring to FIGS. 17-29 and 38, the various blocks shown in those figures depict mainly the conceptual functions and signal flow. The actual circuit implementation may or may not contain separately identifiable hardware for the various functional blocks. For example, one may combine the functionality of various blocks into one circuit block, as desired. Furthermore, one may realize the functionality of a single block in several circuit blocks, as desired. The choice of circuit implementation depends on various factors, such as particular design and specifications for a given implementation, as persons of ordinary skill in the art who read the disclosure of the invention will understand.

[0319] Note that one may use the inventive digital architecture and DC offset reduction apparatus and methods in a variety of RF apparatus, such as those described above with respect to partitioning and digital interface concepts, by making modification within the knowledge of persons of ordinary skill in the art who read the description of the invention. Further modifications and alternative embodiments of the invention will be apparent to persons skilled in

the art who read this description of the invention. Accordingly, this description teaches those skilled in the art the manner of carrying out the invention and are to be construed as illustrative only.

[0320] The forms of the invention shown and described should be taken as the presently preferred embodiments. Persons skilled in the art may make various changes in the shape, size and arrangement of parts without departing from the scope of the invention described in this document. For example, persons skilled in the art may substitute equivalent elements for the elements illustrated and described here. Moreover, persons skilled in the art who have the benefit of this description of the invention may use certain features of the invention independently of the use of other features, without departing from the scope of the invention.

We claim:

1. A receiver digital circuitry, comprising:

digital down-converter circuitry configured to mix a digital input signal provided by a receiver analog circuitry with a digital intermediate frequency (IF) local oscillator signal to generate a digital down-converted signal; and

digital filter circuitry configured to filter the digital down-converted signal to generate a filtered digital signal,

wherein the digital filter circuitry provides a notch at a frequency that corresponds to a residual DC offset of the receiver analog circuitry.

2. A radio-frequency (RF) apparatus, comprising:

a first circuit partition, comprising receiver analog circuitry configured to produce a digital receive signal from an analog radio-frequency signal; and

a second circuit partition, comprising receiver digital circuitry configured to accept the digital receive signal, wherein the first and second circuit partitions are partitioned so that interference effects between the first circuit partition and the second circuit partition tend to be reduced.

* * * * *