



US 20220017156A1

(19) **United States**

(12) **Patent Application Publication**

**Fenton**

(10) **Pub. No.: US 2022/0017156 A1**

(43) **Pub. Date: Jan. 20, 2022**

(54) **SPLINE JOINTS AND CONTAINER HAVING SAME**

(52) **U.S. Cl.**  
CPC ..... **B62D 33/046** (2013.01); **B62D 33/044** (2013.01); **B65D 88/12** (2013.01); **B65D 90/08** (2013.01); **B65D 90/026** (2013.01)

(71) Applicant: **STI Holdings, Inc.**, Stoughton, WI (US)

(72) Inventor: **Gary L. Fenton**, Edgerton, WI (US)

(57) **ABSTRACT**

(21) Appl. No.: **17/490,308**

(22) Filed: **Sep. 30, 2021**

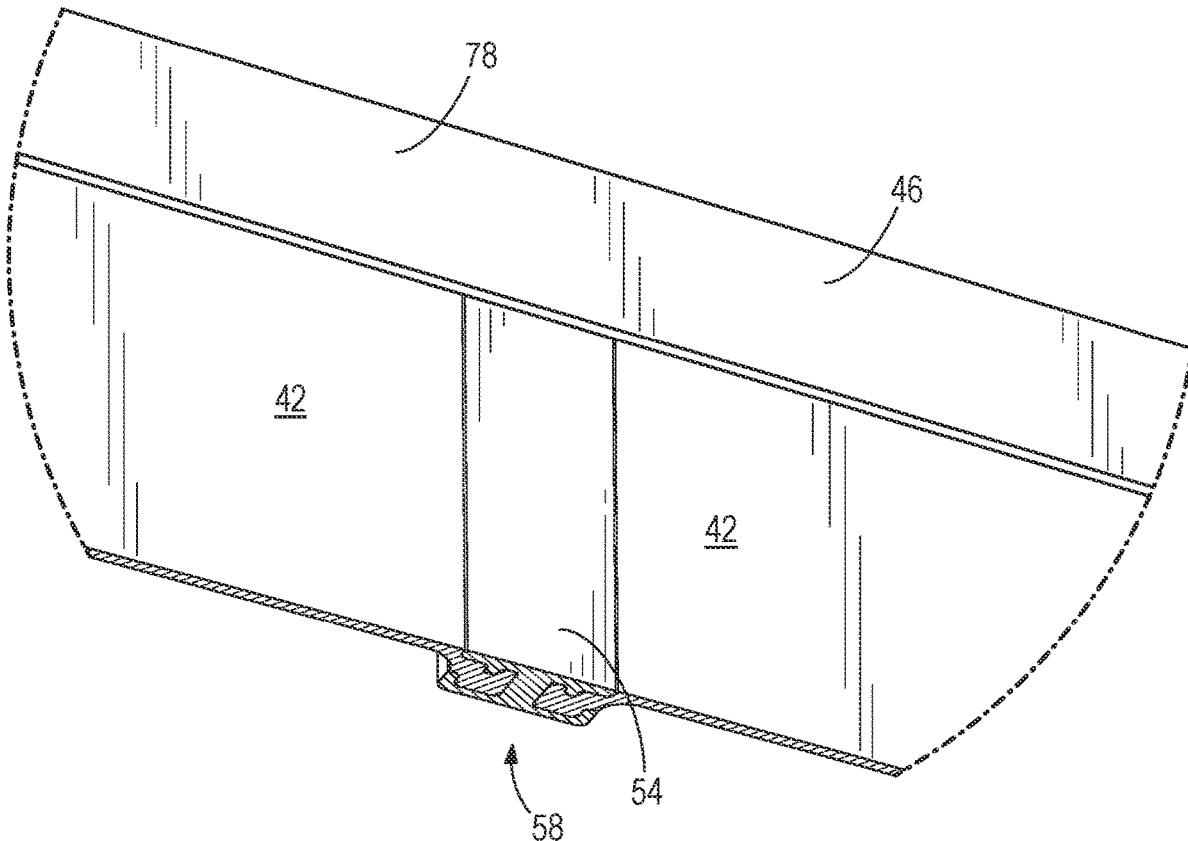
**Related U.S. Application Data**

(63) Continuation of application No. 16/852,646, filed on Apr. 20, 2020, now Pat. No. 11,136,073, which is a continuation of application No. 15/962,341, filed on Apr. 25, 2018, now Pat. No. 10,625,790.

**Publication Classification**

(51) **Int. Cl.**  
**B62D 33/04** (2006.01)  
**B65D 90/02** (2006.01)  
**B65D 90/08** (2006.01)  
**B65D 88/12** (2006.01)

A container including a first panel with a first edge having a first protrusion with a first contoured profile with at least one projection, a second panel with a second edge having a second protrusion with a second contoured profile with at least one projection, and a spline with a first channel that defines a recess with an interior profile, and a second channel separate from the first channel that defines a recess with an interior profile. The first and second channels receive the first and second protrusions, respectively, such that the first contoured profile is complementary to a portion of the interior profile and the second contoured profile is complementary to a portion of the interior profile. The first and second panel include a mid-section extending from the first and second edges, respectively. The first and second edges have a greater thickness than the thickness of the mid-sections.



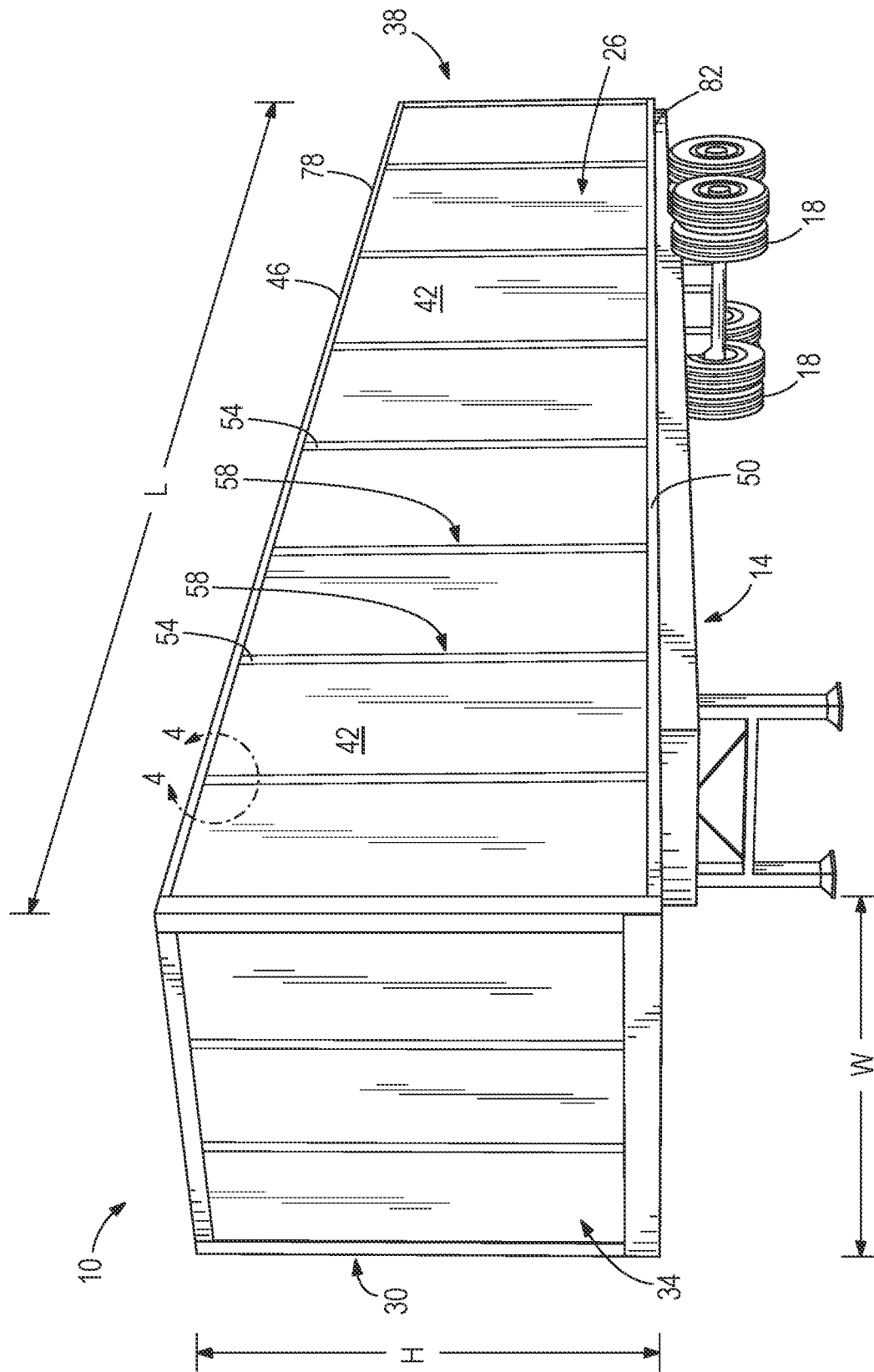


FIG. 1

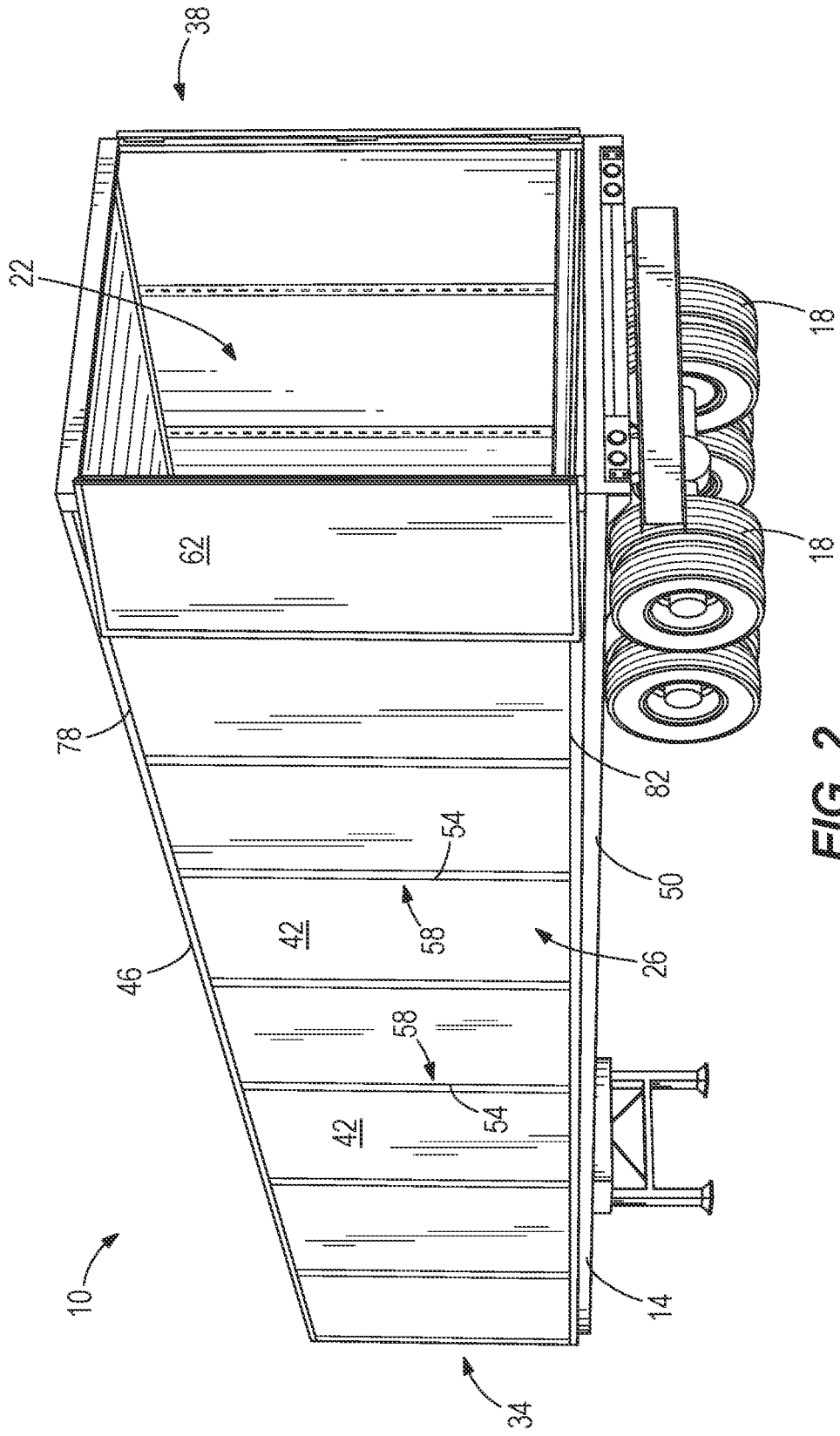
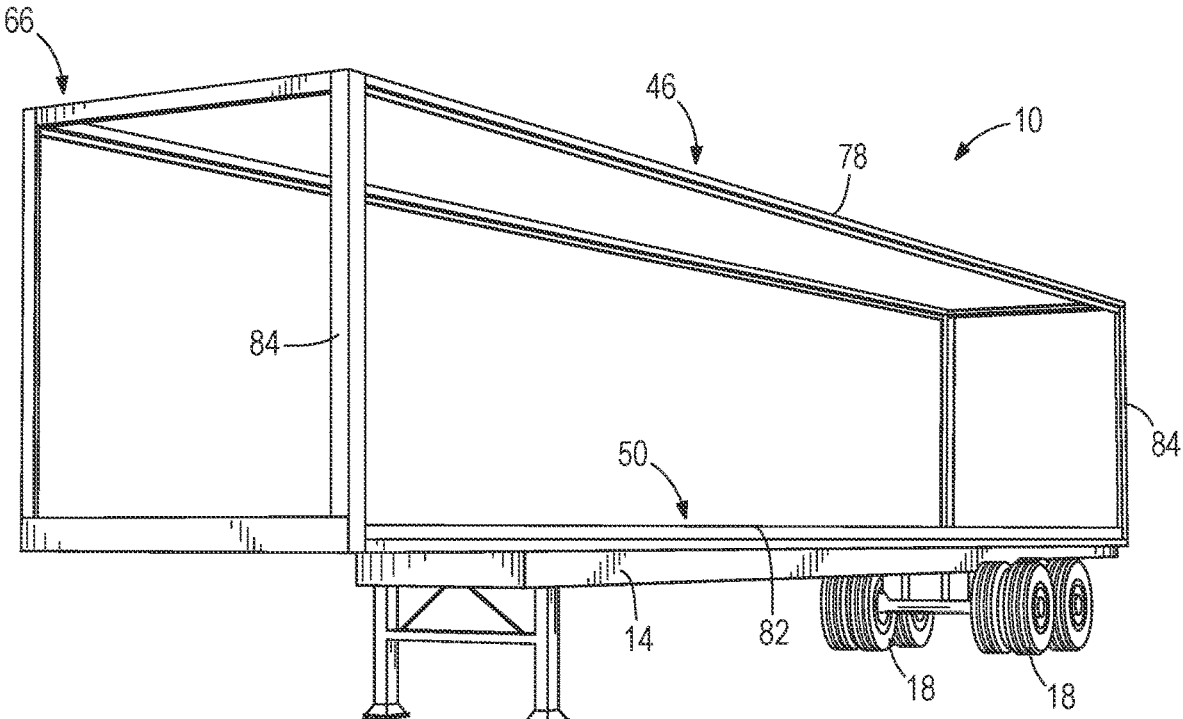
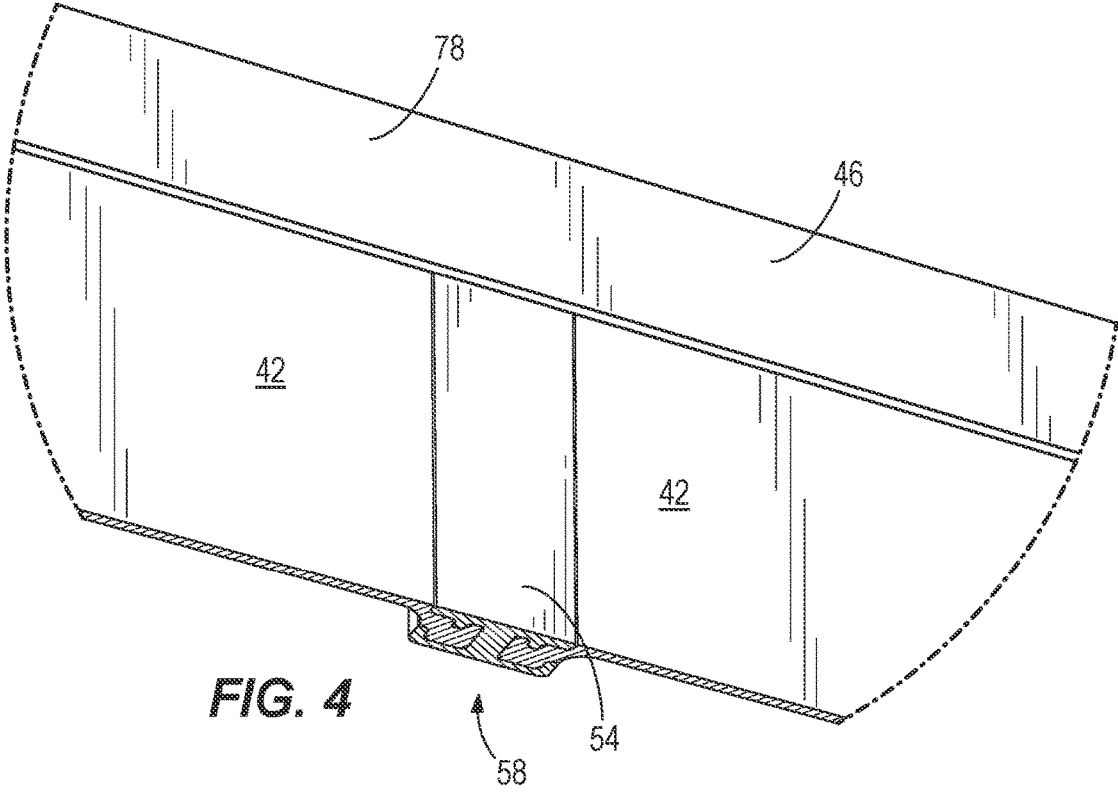


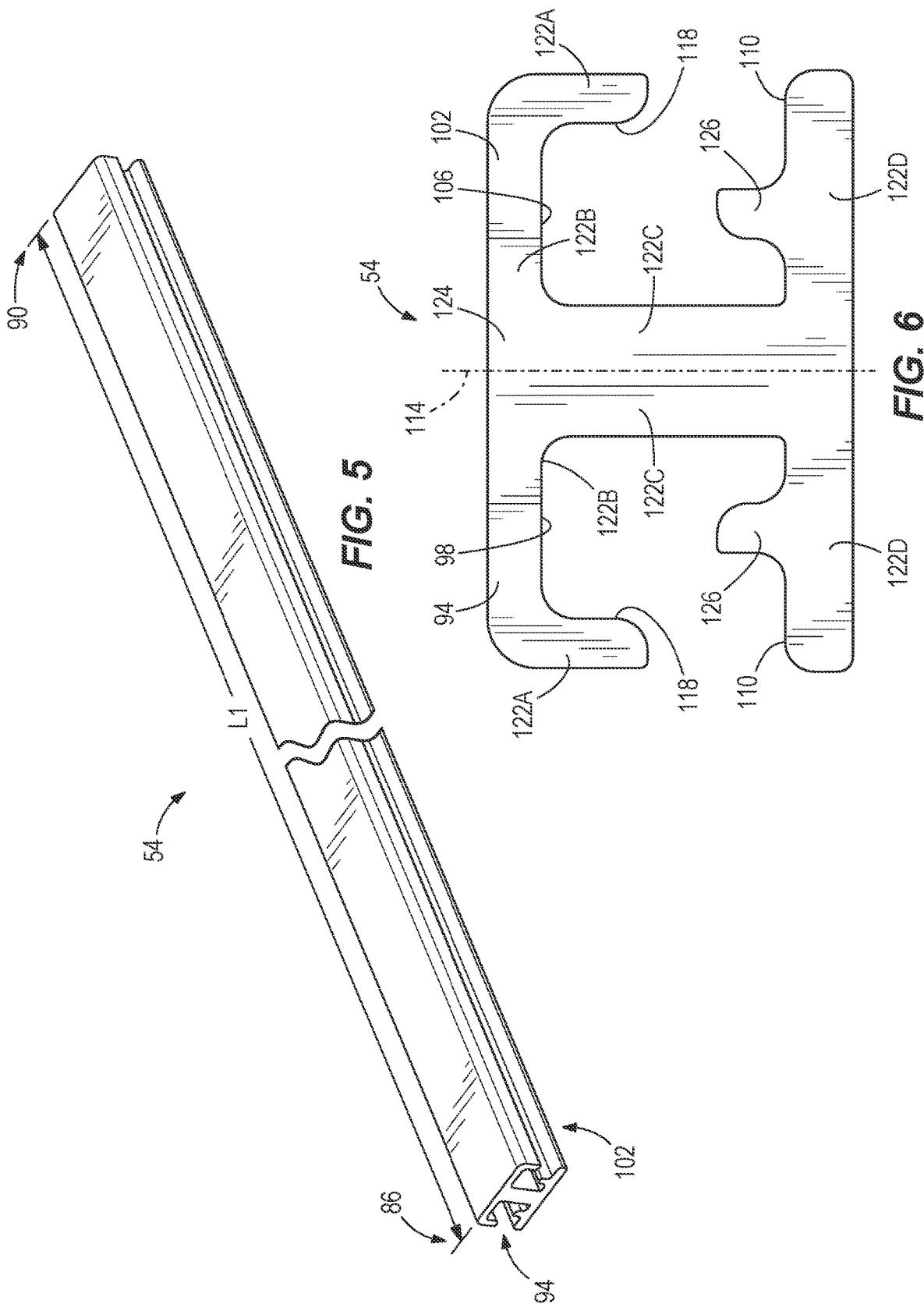
FIG. 2

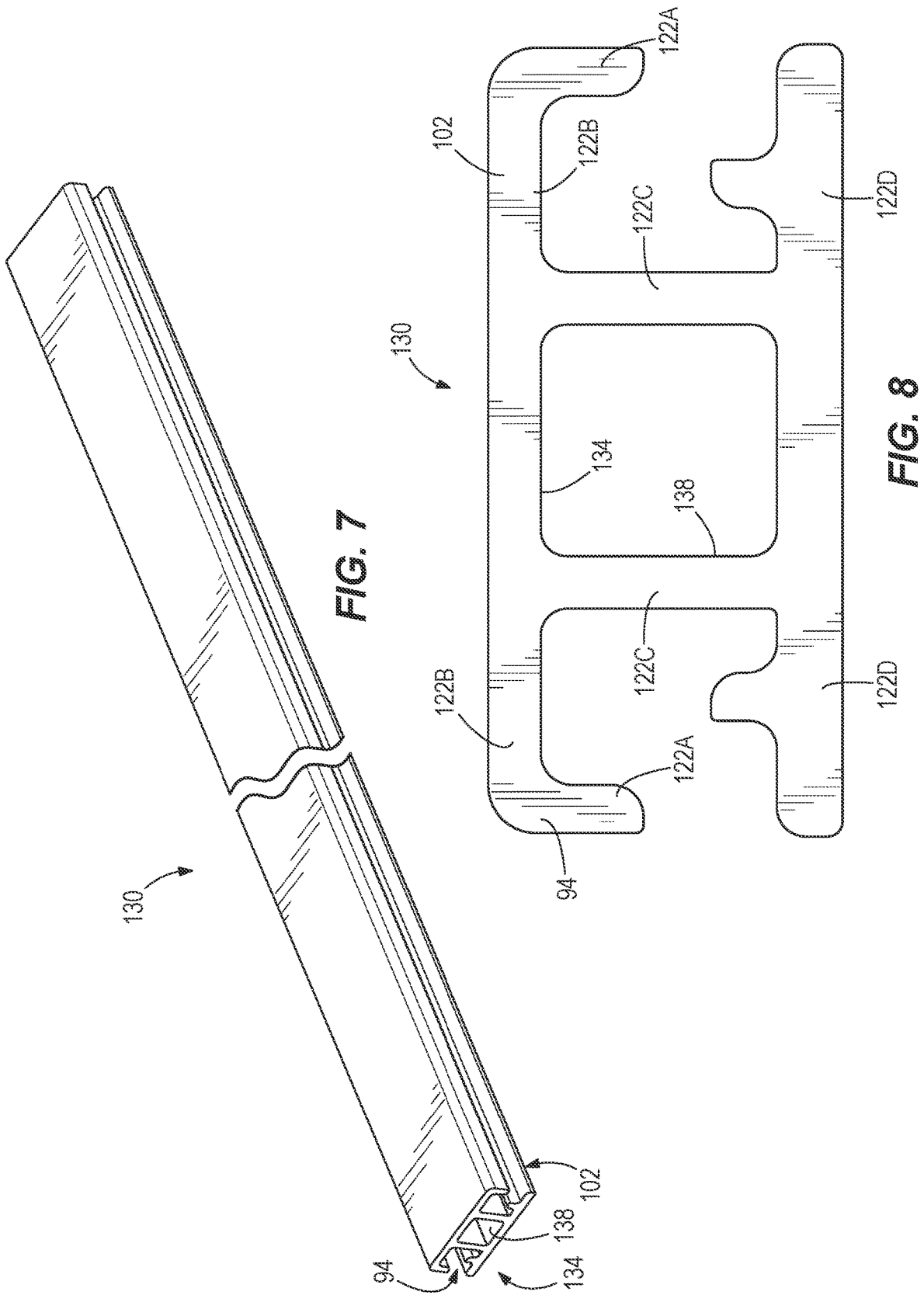


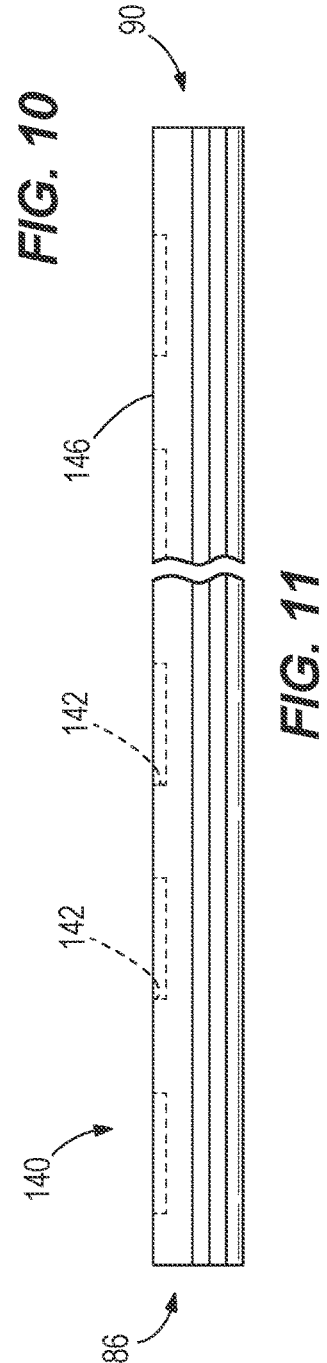
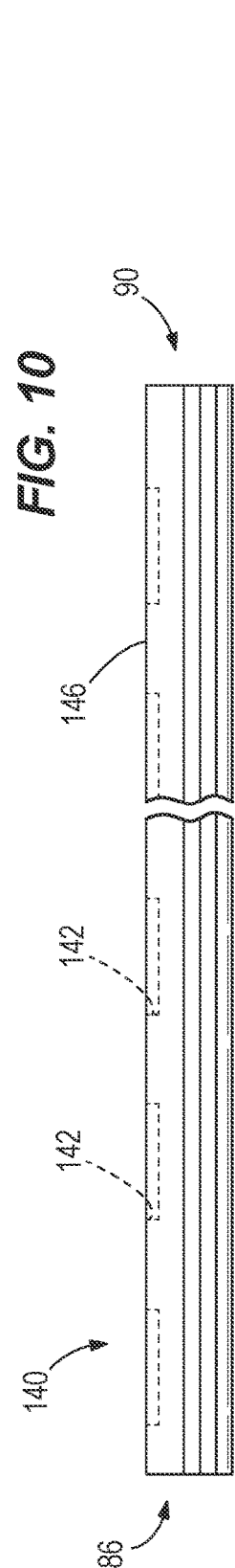
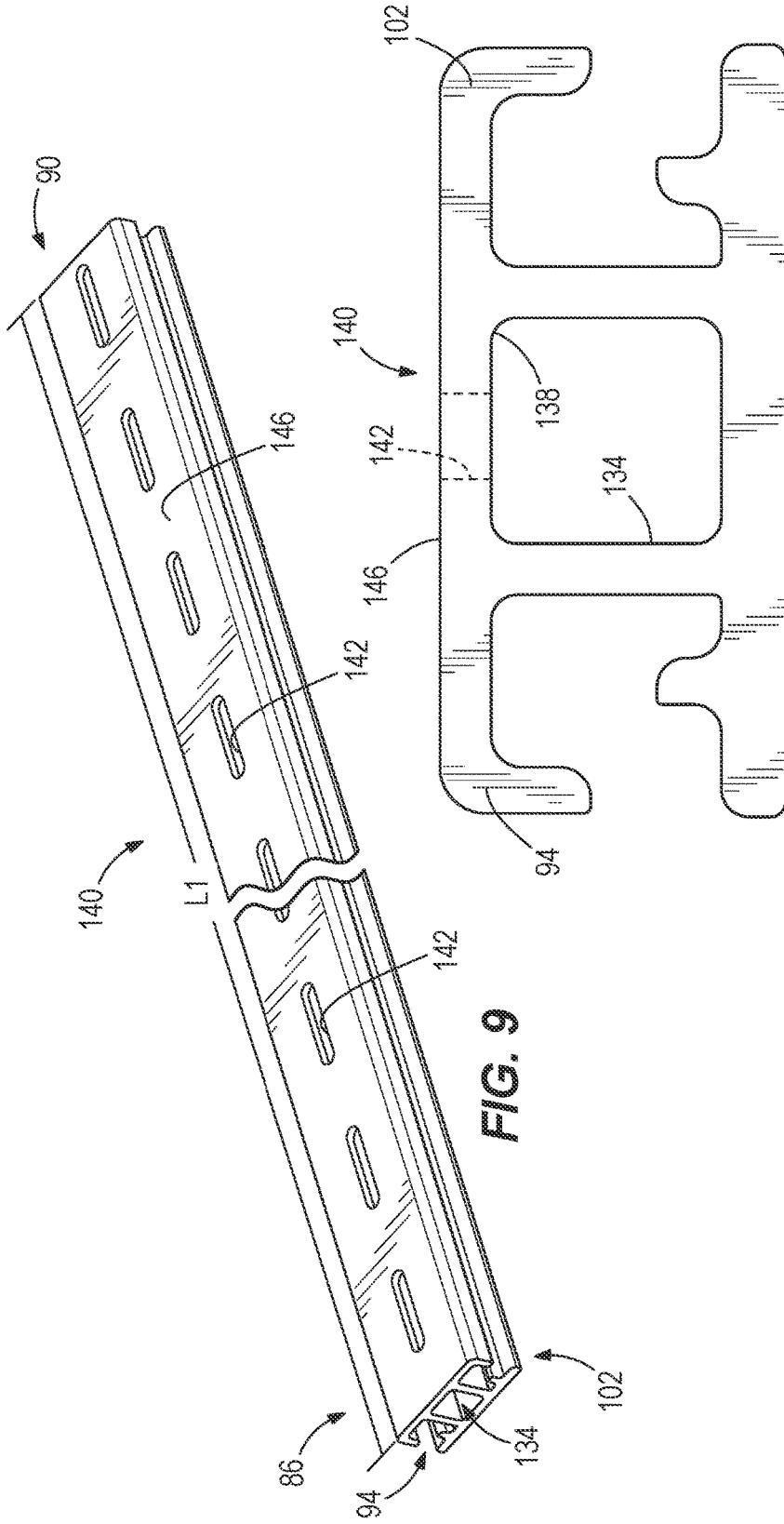
**FIG. 3**

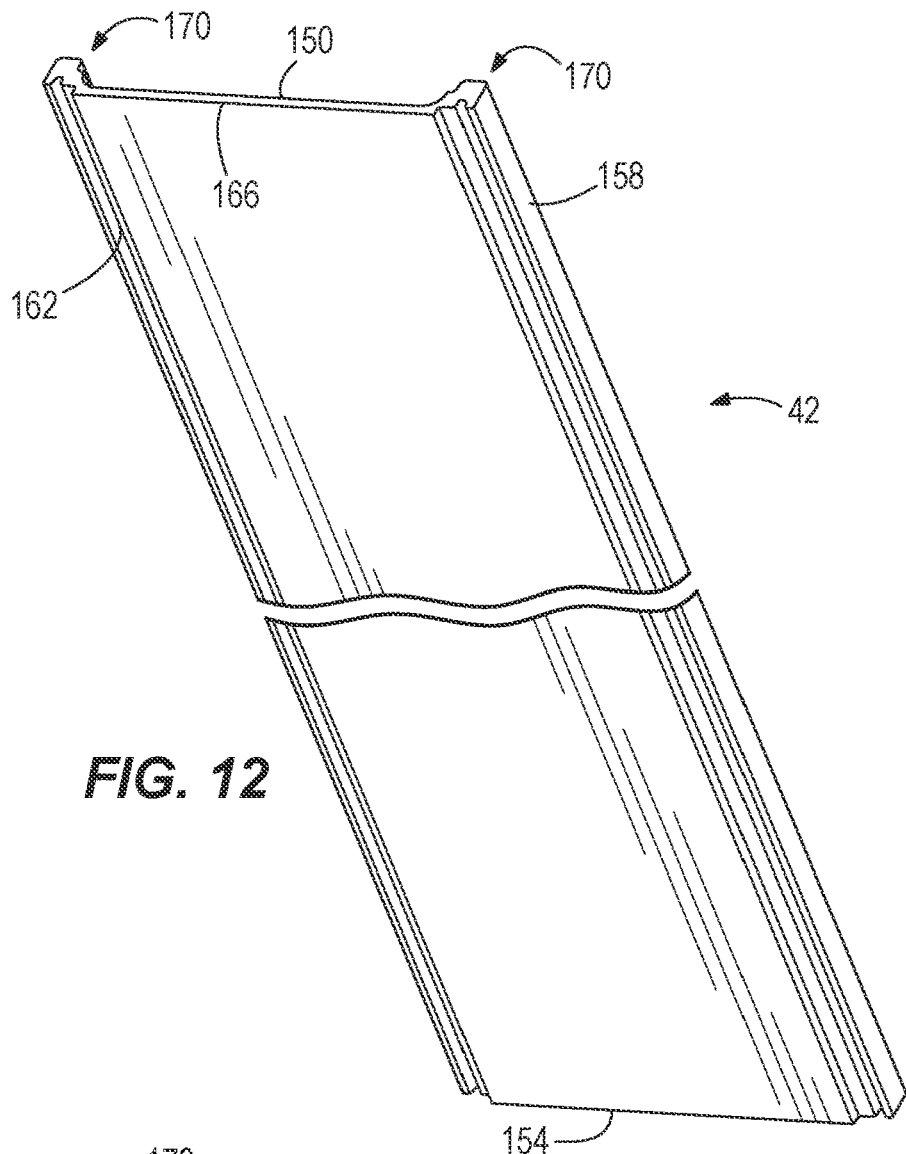


**FIG. 4**

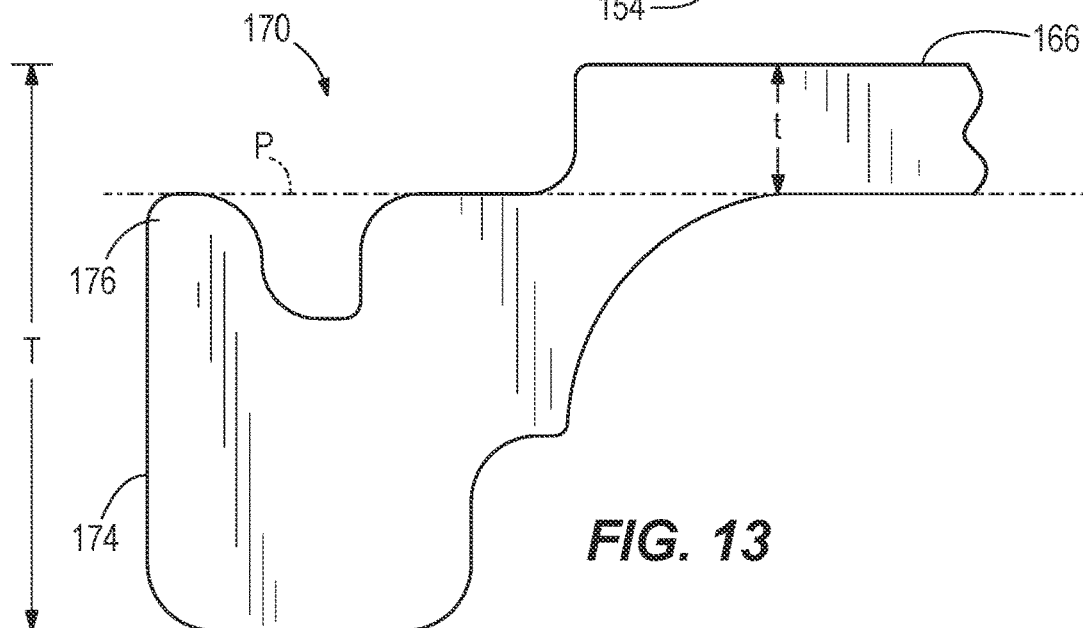






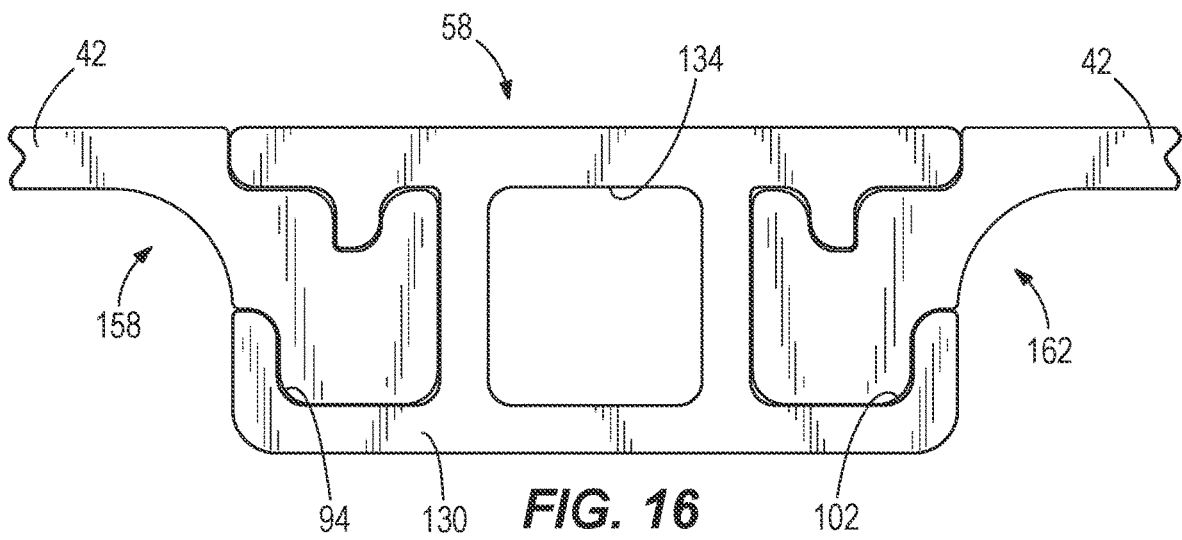
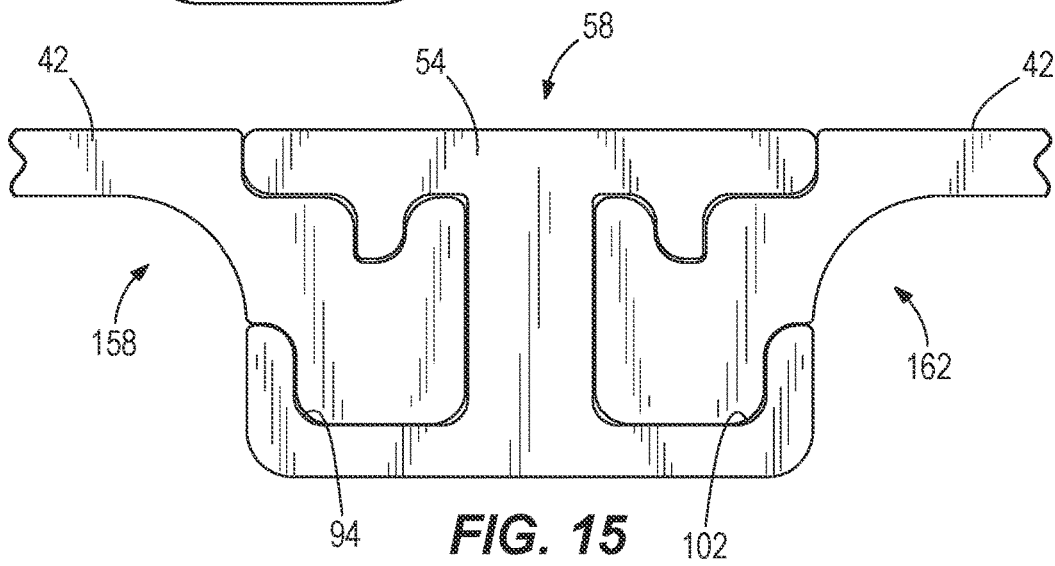
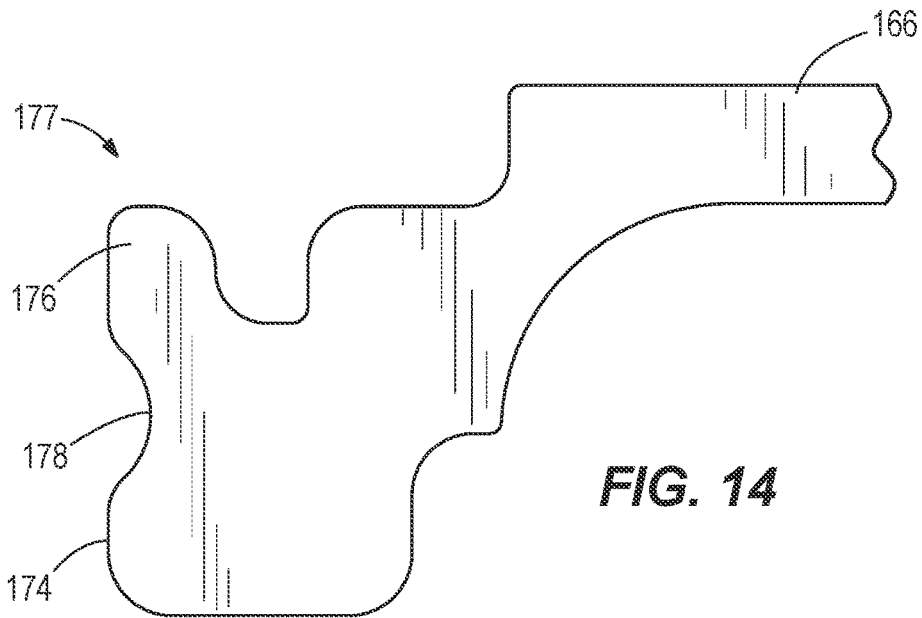


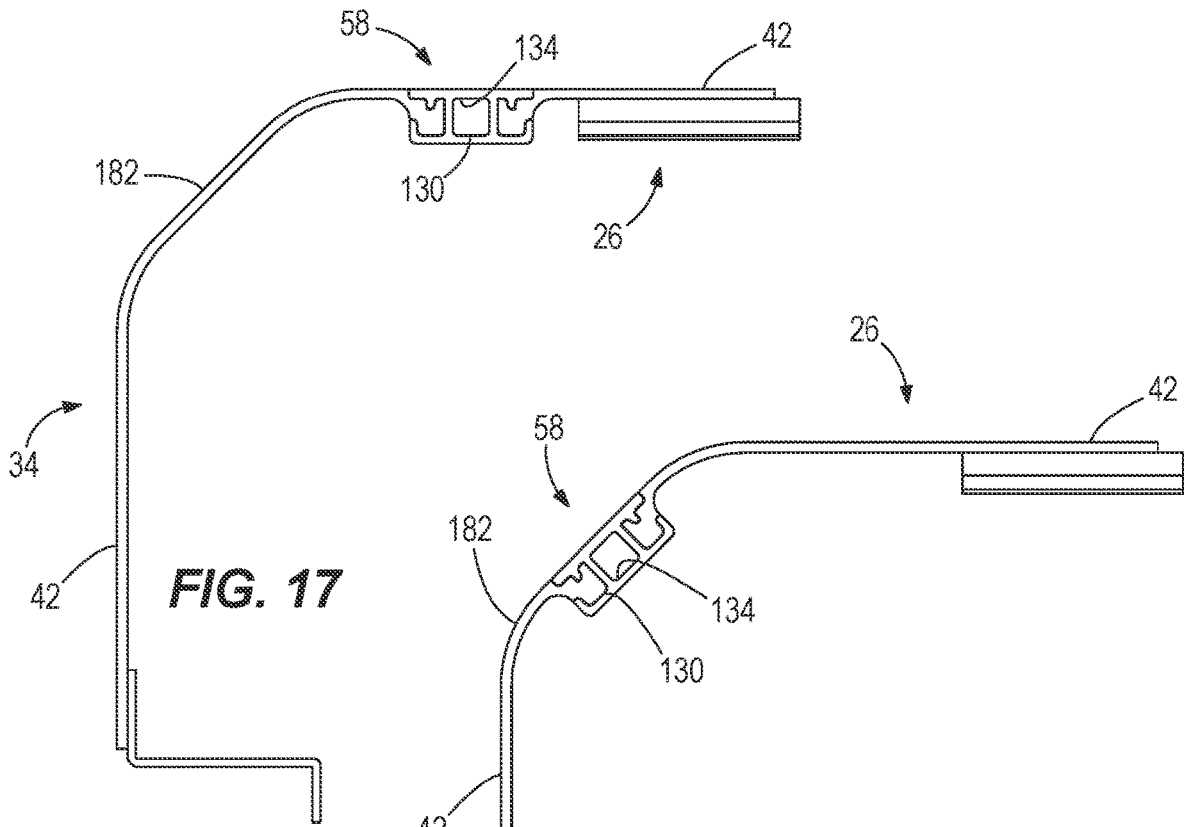
**FIG. 12**



**FIG. 13**

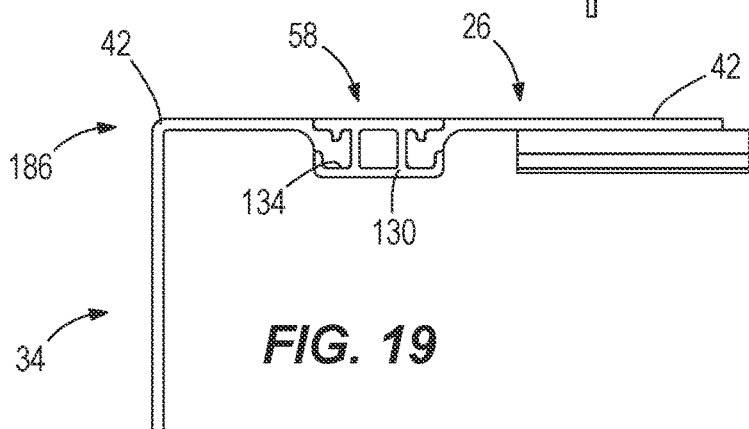




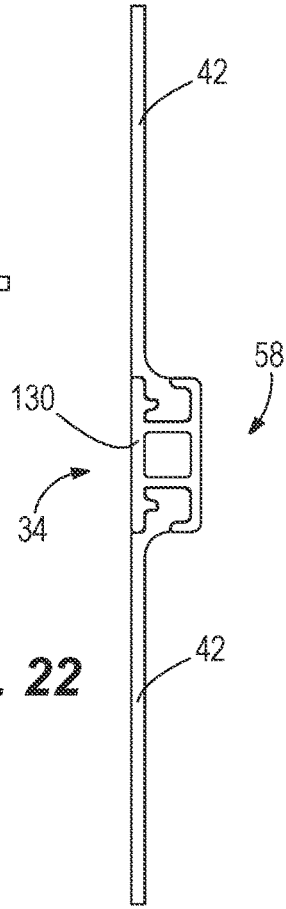
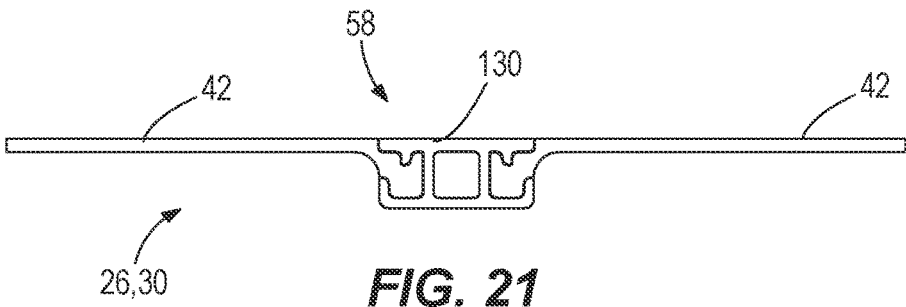
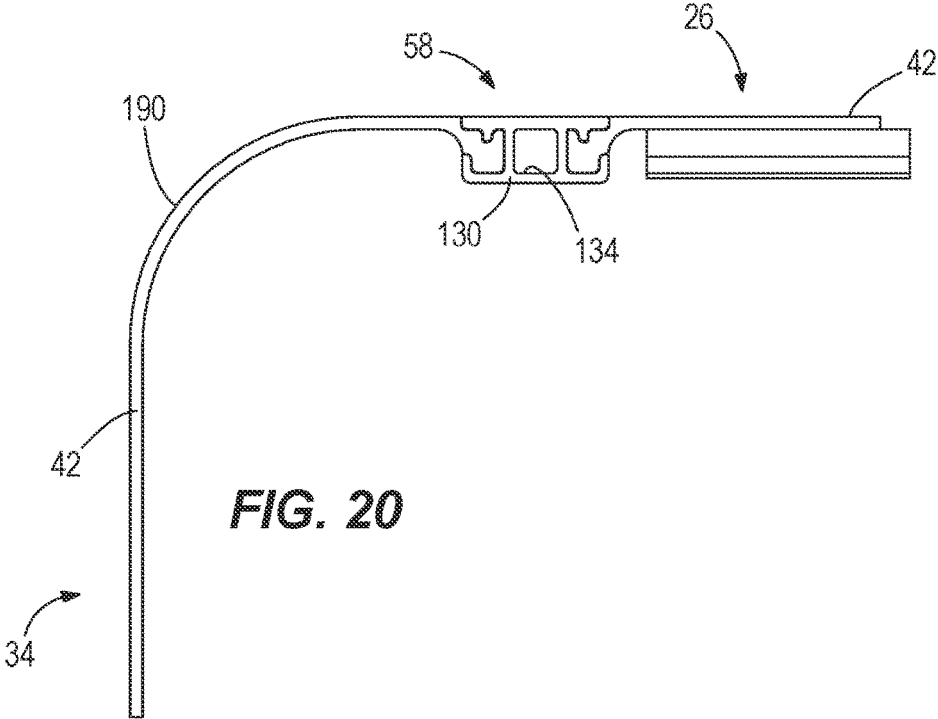


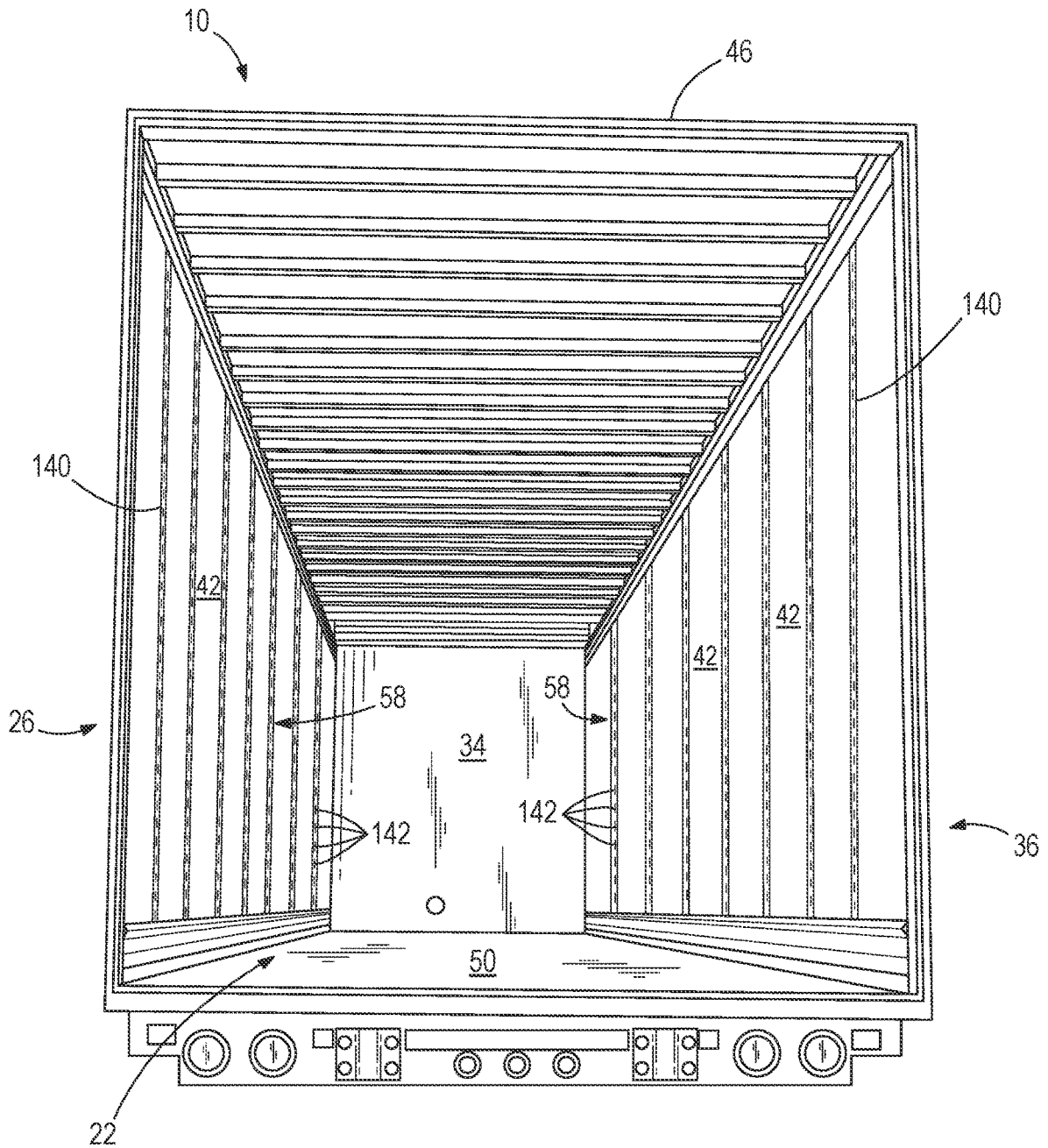
**FIG. 17**

**FIG. 18**



**FIG. 19**





**FIG. 23**

## SPLINE JOINTS AND CONTAINER HAVING SAME

### RELATED APPLICATIONS

**[0001]** This application is a continuation of U.S. application Ser. No. 16/852,646, filed Apr. 20, 2020, now U.S. Pat. No. 11,136,073, which is a continuation of U.S. application Ser. No. 15/962,341, filed Apr. 25, 2018, now U.S. Pat. No. 10,625,790, the entire contents of both of which are hereby incorporated by reference.

### FIELD OF THE INVENTION

**[0002]** The present invention relates to containers, and in particular, to joints for connecting wall panels of containers.

### BACKGROUND

**[0003]** Containers, for example commercial containers transported by trucks, commercial nautical vessels, trains, and the like include a set of walls that enclose the space of the container. The walls and connections therebetween are typically formed by assembling respective wall panels together forming a joint, often including additional splice plates, and then fastening the joints with numerous fasteners such as screws or rivets.

### SUMMARY

**[0004]** In one aspect, the invention provides a container defining a cargo receiving interior defined by a plurality of panels. The container includes a first panel having a first edge. The first edge including a first protrusion with a first contoured profile. The first contoured profile includes at least one projection. The container also includes a second panel with a second edge. The second edge includes a second protrusion with a second contoured profile. The contoured profile includes at least one projection. The container further includes a spline having a first channel that defines a recess with an interior profile and a second channel separate from the first channel that defines a recess with an interior profile. The first channel receives the first protrusion of the first panel such that the first contoured profile is complementary to a portion of the interior profile. The second channel receives the second protrusion of the second panel such that the second contoured profile is complementary to a portion of the interior profile. The first panel further includes a mid-section extending from the first edge and the second panel further includes a mid-section extending from the second edge. The first edge has a greater thickness than the thickness of the mid-section of the first panel and the second edge has a greater thickness than the thickness of the mid-section of the second panel.

**[0005]** In another aspect, the invention provides a container defining a cargo receiving interior defined by a plurality of panels. The container including a first contoured edge of a first panel, a second contoured edge of a second panel, and a spline with a first channel that receives the first contoured edge and a second channel that receives the second contoured edge to form a spline joint securing the first and second panels together. The first and second channels are symmetrical with openings in opposite directions. Each of the first and second contoured edges includes a concavity containing an adhesive that bonds a surface of the respective first and second contoured edges with a surface of respective first and second channels of the spline.

**[0006]** In another aspect, the invention provides a method of assembling a container. The container defines a cargo receiving interior defined by a plurality of panels. The method includes providing a first panel with a first contoured edge and a second panel with a second contoured edge. The first panel and the second panel are held fixed relative to each other to define a space between the first and second contoured edges. The method also includes providing a spline with two symmetrical channels that open in opposite directions and sliding the spline axially and simultaneously onto the first and second contoured edges and into the space therebetween so that a first one of the two symmetrical channels receives the first contoured edge and a second one of the two symmetrical channels receives the second contoured edge to from a spline joint securing the first panel to the second panel. The method further includes, after the first and second panels are secured, applying an adhesive to a concavity on the first contoured edge to bond a surface of the first contoured edge with a surface of one of the two symmetrical channels, and applying an adhesive to a concavity on the second contoured edge to bond a surface of the second contoured edge with a surface of the other of the two symmetrical channels after the first and second panels are secured.

**[0007]** In another aspect, the invention provides a container defining a cargo receiving interior defined by a plurality of panels. The container includes a first panel having a first edge. The first edge including a first protrusion with a first contoured profile. The first contoured profile includes at least one projection. The container also includes a second panel with a second edge. The second edge includes a second protrusion with a second contoured profile. The contoured profile includes at least one projection. The container further includes a spline having a first channel that defines a recess with an interior profile and a second channel separate from the first channel that defines a recess with an interior profile. The first channel receives the first protrusion of the first panel such that the first contoured profile is complementary to a portion of the interior profile. The second channel receives the second protrusion of the second panel such that the second contoured profile is complementary to a portion of the interior profile. Each of the first and second contoured profiles includes a concavity containing an adhesive that bonds a surface of the respective first and second contoured profiles with a surface of the interior profile of the respective first and second channels of the spline.

**[0008]** Other aspects of the invention will become apparent by consideration of the detailed description and accompanying drawings.

### BRIEF DESCRIPTION OF THE DRAWINGS

**[0009]** FIG. 1 is a first perspective view of a container.  
**[0010]** FIG. 2 is a second perspective view of the container of FIG. 1.  
**[0011]** FIG. 3 is a perspective view of the container of FIG. 1 without walls.  
**[0012]** FIG. 4 is a perspective view of a spline joint on the container of FIG. 1.  
**[0013]** FIG. 5 is a perspective view of a spline according to one embodiment of the invention.  
**[0014]** FIG. 6 is a top view of the spline of FIG. 5.  
**[0015]** FIG. 7 is a perspective view of a spline according to another embodiment of the invention.

[0016] FIG. 8 is a top view of the spline of FIG. 7.  
 [0017] FIG. 9 is a perspective view of a spline according to another embodiment of the invention.  
 [0018] FIG. 10 is a top view of the spline of FIG. 9.  
 [0019] FIG. 11 is a side view of the spline of FIG. 9.  
 [0020] FIG. 12 is a perspective view of a wall panel of the container of FIG. 1.  
 [0021] FIG. 13 is a detail view of a side edge of the wall panel of FIG. 12 according to one embodiment of the invention.  
 [0022] FIG. 14 is a detail view of a side edge of the wall panel of FIG. 12 according to another embodiment of the invention.  
 [0023] FIG. 15 is a top view of the spline joint of FIG. 4.  
 [0024] FIG. 16 is a top view of a spline joint according to another embodiment of the invention.  
 [0025] FIG. 17 is a top view of a spline joint according to another embodiment of the invention.  
 [0026] FIG. 18 is a top view of a spline joint according to another embodiment of the invention.  
 [0027] FIG. 19 is a top view of a spline joint according to another embodiment of the invention.  
 [0028] FIG. 20 is a top view of a spline joint according to another embodiment of the invention.  
 [0029] FIG. 21 is a top view of a spline joint according to another embodiment of the invention.  
 [0030] FIG. 22 is a top view of a spline joint according to another embodiment of the invention.  
 [0031] FIG. 23 is a perspective view of an interior of the container of FIG. 1.

#### DETAILED DESCRIPTION

[0032] Before any embodiments of the invention are explained in detail, it is to be understood that the invention is not limited in its application to the details of construction and the arrangement of components set forth in the following description or illustrated in the accompanying drawings. The invention is capable of other embodiments and of being practiced or of being carried out in various ways. It should be understood that the description of specific embodiments is not intended to limit the disclosure from covering all modifications, equivalents, and alternatives falling within the spirit and scope of the disclosure. Also, it is to be understood that the phraseology and terminology used herein is for the purpose of description and should not be regarded as limiting.

[0033] The term “laterally” or variations thereof refer to a sideways direction. The terms “top,” “upper,” “bottom,” and “lower” are intended to indicate directions when viewing the container when positioned for use. The term “coupled” means connected to or engage with, whether either directly or indirectly, for example with an intervening member, and does not require the engagement to be fixed or permanent, although engagement can be fixed or permanent. It should be understood that the use of numerical terms “first,” “second,” “third,” etc. as used herein does not refer to any particular sequence or order of components; for example, “first” and “second” portions may refer to any sequence of such components, and is not limited to the first and second components of a particular configuration.

[0034] FIGS. 1 and 2 illustrate a container, embodied here as a trailer 10 for over-the-road use with a truck to transport large cargo volumes. In other embodiments, the container may be a fixed storage construction, a cargo container, a

shipping container, a straight truck, or the like. As shown, the trailer 10 is a semi-trailer configured for use with a road tractor (i.e., in forming a so called 18-wheeler). Aspects of the invention are not necessarily limited to such a trailer 10, and aspects of the disclosure will be understood as also applying to other trailers and containers of various configurations. The trailer 10 includes a chassis 14 having axles with multiple sets of wheels 18, although similar containers may be provided with alternate rolling chassis configurations or none at all. The trailer 10 defines a length L in a longitudinal or transport direction. The length L can be 53 feet in some constructions, although the trailer 10 can be manufactured in other lengths greater than or less than 53 feet. Perpendicular to the longitudinal direction, the trailer 10 defines a width W and a height H. The width W cooperates with the length L to define a plan view footprint of the trailer 10, while the height H of the trailer 10 is measured perpendicular to the footprint (i.e., perpendicular to the ground). Subtracting for wall thicknesses, the length L, the width W, and the height H cooperate to define a cargo receiving interior 22 (FIG. 2) of the trailer 10.

[0035] The trailer 10 includes a first side defined by a first side wall 26, a second side defined by a second side wall 30 opposite the first side wall 26, a front defined by a front wall 34, and a rear 38. Wall panels 42 may form walls that span the first side wall 26, second side wall 30, and front wall 34. Each of the first side wall 26, second side wall 30, and front wall 34 can be constructed of one or more wall panels 42. Further in some embodiments, a wall panel may wrap around a corner of the trailer and form parts of multiple walls (e.g., the front wall and one of the first and second side walls). All of the wall panels 42 extend between a roof 46 of the trailer 10 and a floor 50 of the trailer 10. Consecutive wall panels 42 can be joined together by a spline 54 forming a joint (e.g., spline joint 58, FIG. 4) that extends parallel to the direction of the height H of the trailer 10 between the roof 46 and floor 50 of the trailer 10. As shown in FIG. 2, the rear 38 of the trailer 10 includes at least one door panel 62 provided to selectively open for accessing the interior 22 for loading and unloading.

[0036] As shown in FIG. 3, the trailer 10 includes a frame 66 including, on each side, a top rail 78 adjacent the roof 46, a bottom rail 82 adjacent the floor 50, and support posts 84. The top rail 78 and the bottom rail 82 extend parallel to the longitudinal or lengthwise direction of the trailer 10. The support posts 84 are positioned perpendicular to the longitudinal direction and spaced along the length L of the trailer 10.

[0037] With reference to FIGS. 5 and 6, the spline 54 includes a first end 86, a second end 90 opposite the first end 86, and a length L1 between the first and second ends 86, 90. The length L1 of the spline 54 defines the length of the spline joint 58. The spline 54 also includes a first channel 94 that defines a first recess 98 and a second channel 102 that defines a second recess 106. Each of the first and second channels 94, 102 is formed as an open-channel or structure and the first and second channels 94, 102 forming the spline 54 can be integrally formed as a single piece or separately formed and joined together. The first and second channels 94, 102 both have openings 110 to their respective recesses 98, 106 that open in opposite directions of one another. The first and second channels 94, 102 are also symmetrical about an axis 114 that extends through the center of the spline 54. Each of the first and second recesses 98, 106 includes a

respective interior profile 118 that spans the inside of their respective channels 94, 102. The interior profiles 118 are defined along four sides 122A-D that form a rectangular arrangement with adjacent sides 122A-D being perpendicular to one another. The two directly adjacent sides 122C of the respective first and second channels 94, 102 cooperatively form a web 124 of the spline 54 that extends between, on one end of the web 124, the sides 122C arranged toward the interior and, on the other end of the web 124, the sides 122D arranged toward the exterior. Although referred to herein as individual sides, the two sides 122C are arranged in the illustrated construction to be coextensive, forming one side of the spline 54 as a whole, and the same may be said of the two sides 122D. For example, the spline 54 may be viewed as having a modified I-beam shape, where the web 124 extends between the midsections of two parallel, spaced sides.

[0038] Each of the interior profiles 118 of the spline 54 includes a male projection 126 that extends from one side (e.g., the exterior side 122D) of the channel 94, 102 into the open space that otherwise forms the female recess 98, 106. As illustrated, each projection 126 extends perpendicularly from the side 122D. In the case that the projections 126 extend from the exterior sides 122D in both channels 94, 102, this means that the projections 126 extend in a direction toward the interior of the trailer 10. As shown in FIG. 6, one side of each projection 126 is flat while another side (e.g., an opposite side) is curved. As shown, the two projections 126 of the spline 54 are arranged so that the two curved sides are facing each other and the two flat sides are facing away from each other. Although the interior profiles 118 are shown to include exactly one pair of mirror-image projections 126, one or both of the interior profiles 118 can alternately include more or fewer projections 126. Further, the projections 126 are not mirror-images in other constructions, and each projection 126 can have any convenient number of flat and/or round sides. In further embodiments, each interior profile 118 may include more or less than the four sides as illustrated, and the sides of the interior profiles may differ in shape from that shown.

[0039] FIGS. 7 and 8 illustrate a spline 130 according to another embodiment. The spline 130 is similar to the spline 54, with like features being represented by like reference numerals. The spline 130 includes an additional channel 134 (e.g., a central channel 134) that extends the length L1 of the spline 130 at a position between the first and second channels 94, 102. The central channel 134 can be positioned exactly centrally within the spline 130, or offset therefrom. Although the central channel 134 has a regular, symmetrical shape, alternate shapes are optional. The central channel 134 is defined between the separate, spaced apart sides 122C of the first channel 94 and the second channel 102. These two sides 122C form parallel webs that bound the central channel 134. The central channel 134 defines an interior 138 that is rectangular, notwithstanding the rounded corners, and is positioned between the first and second channels 94, 102.

[0040] FIGS. 9-11, illustrate a spline 140 according to another embodiment. The spline 140 is similar to the splines 54, 130 with like features being represented by like reference numerals. The spline 140 includes the central channel 134 and a plurality of slots 142 (e.g., logistic slots) that extend into the interior 138 of the central channel 134 through an interior-facing wall 146 of the spline 140. The slots 142 extend the entire length L1 of the spline 140 from

the first end 86 to the second end 90 of the spline 140. The slots 142 may take any number of different shapes, including the simple elongate holes as illustrated. When a spline joint 58 including a spline 140 is assembled, the logistic slots 142 are exposed to the interior 22 of the trailer 10 so as to provide attachment points for load separators or other restraints that may be secured to the interior 22 of the trailer 10.

[0041] Referring to FIG. 12, some or all of the wall panels 42 of the trailer 10 include a top edge 150, a bottom edge 154 opposite the top edge 150, a first side edge 158 (right), a second side edge 162 (left) opposite the first side edge 158, and a mid-section 166 spanning between the first and second side edges 158, 162. In the illustrated embodiment, the first and second side edges 158, 162 extend the entire length of the wall panels 42 from the bottom edge 154 to the top edge 150. In other embodiments, the first and second side edges 158, 162 only extend a majority portion of the length between the top and bottom edges 150, 154. Referring now to FIG. 13, the first and second side edges 158, 162 of any respective wall panel 42 are oblong shaped and include a protrusion 170 that extends towards the interior 22 of the trailer 10 when the wall panel 42 is positioned for use. In other words, the protrusion 170 is offset inwards from a plane P that is defined by an interior surface of the wall panel 42 at a location (e.g., the mid-section 166) along the wall panel 42 that is spaced away from the protrusion 170. Each of the protrusions 170 on respective first and second side edges 158, 162 of the wall 42 include a contoured profile 174. In other words, the contoured profiles 174 are irregularly shaped and not strictly defined by flat or straight ends. The contoured profile 174 includes a projection 176 that extends towards the plane P (e.g., extending toward the exterior when assembled for use). In the illustrated embodiment, the contoured profile 174 of the protrusion 170 on the first side edge 158 of the wall panel 42 corresponds to the interior profile 118 of the first channel 94 of the spline 54 and the contoured profile 174 of the protrusion 170 on the second side edge 162 of the wall panel 42 corresponds to the interior profile 118 of the second channel 102 of the spline 54. The protrusion 170 on the first edge 158 of the wall 42 is complementary in shape to the first channel 94, and the protrusion 170 on the second edge 162 of the wall panel 42 is complementary in shape to the second channel 102 of the spline 54. Although in the illustrated embodiment, the contoured profiles 174 are mirror-images of one another, each including a single projection 176, the contoured profiles 174 are, in some constructions, different from each other and either one or both may differ in shape from that shown herein, e.g., the contoured profile 174 may include more or fewer projections 176 or projections 176 of alternate shapes. It is noted here that the projections 176 as shown, similar to the spline projections 126, include one flat side and one curved side opposite the flat side. In some embodiments, the contoured profiles 174 may correspond (e.g., form fit) to the interior profiles 118 of the channels 94, 102. In further embodiments, the contoured profile 174 may be complementary in shape to only a portion(s) of the shape of the interior profiles 118 of the spline 54. In other embodiments, the contoured profiles 174 may be entirely complementary in shape to the interior profiles 118 of the spline 54. In other words, the contoured profiles 174 may fully occupy the space provided by the recesses 98, 106 of the spline 54 with no void space. However, some gaps between the

contoured profiles **174** and the interior profiles **118** may exist due to manufacturing tolerances or assembly clearances but the general shapes of the interior profiles **118** and contoured profiles do not vary. The first and second side edges **158, 162** of the wall panels **42** have a thickness **T** that is greater than the thickness **t** of the mid-section **166** of the wall panels **42** when measured in a common direction, i.e., the direction transverse to a direction of extension, or width, of the wall panel **42** between the respective first and second side edges **158, 162**.

[0042] As discussed earlier, the wall panels **42** can span along the side walls **26, 30**, and front wall **34** of the trailer **10**, or a wall panel **42** can span the entire length of one of the side walls **26, 30**, or front wall **34** of the trailer **10**. As such, the length between the first and second side edges **158, 162** of the wall panels **42** can vary significantly, along with the resulting aspect ratio of length to width. The thicknesses **T, t** may also vary as needed, based on construction material and strength requirements. In some embodiments, the first and second side edges **158, 162** of the wall panels **42** may be reinforced with a coating. In some embodiments, the wall panels **42** may be made out of a composite material. In further embodiments, the wall panels **42** may be made out of a sheet metal material such as aluminum.

[0043] FIG. **14** illustrates an alternate protrusion **177** for the first and second side edges **158, 162** of the wall panels **42** according to the preceding description. The protrusion **177** is similar to the protrusion **170**, with like features being represented by like reference numerals. However, the protrusion **177** of FIG. **14** further includes an additional concavity **178**. The concavity **178** extends the entire length of the first and second side edges **158, 162**. The concavity **178** provides a volume and a surface for an adhesive to be applied between the spline **54** and the respective side edges **158, 162**. The adhesive may be applied along the surface of the concavity **178** to bond the first and second side edges **158, 162** to the first and second channels **94, 102** of the spline **54**, respectively.

[0044] To assemble one of the spline joints **58** according to the present disclosure, the spline **54** is installed axially or lengthwise onto the two side edges **158, 162** of respective wall panels **42** being joined. Although reference is made directly to the spline **54** in the discussion of the assembly, it will be appreciated that the discussion also applies to splines of any number of alternate constructions, such as splines **130, 140**. Before the spline **54** is installed, a first side edge **158** of a respective first wall panel **42** is positioned parallel to a second side edge **162** of a respective second wall panel **42**. The first side edge **158** and the second side edge **162** are positionally fixed relative to each other to define a space therebetween, which space corresponds directly to the spacing between the channels **94, 102** of the spline **54**. Next, the spline **54** is arranged such that the first channel **94** is positioned above and aligned with the first side edge **158** of the first wall panel **42**, and the second channel **102** is positioned above and aligned with the second side edge **162** of the second wall panel **42**. The spline **54** is then moved axially in a direction parallel to its lengthwise direction into the space between the two wall panels **42** such that the contoured profiles **174** of the first and second side edges **158, 162** align with and slide into engagement with the interior profiles **118** of the first and second channels **94, 102** of the spline **54**. In some constructions, the spline joints **58** are established with the wall panels **42** in their final position

within the trailer **10**, in which case the spline **54** is installed parallel to the trailer height **H** direction. During lengthwise installation of the spline **54**, the projections **126** on the interior profiles **118** of the first and second channels **94, 102** are aligned with and received by complementary recesses formed in the protrusions **170** along the first and second side edges **158, 162**. Furthermore, the projections **176** on the contoured profiles **174** of the first and second side edges **158, 162** are installed to be positioned directly alongside the projections **126**. Finally, the spline **54** is slid axially further along the contoured profiles **174** of the first and second protrusions **170** to occupy an entire lengthwise extent of the space therebetween, or a majority thereof. The first wall panel **42** is mechanically secured to the second wall panel **42** immediately upon installation of the spline **54**. In the illustrated embodiment, the contoured profile **174** of the first wall panel **42** is entirely complementary to the first interior profile **118** of the first channel **94** and the contoured profile **174** of the second wall panel **42** is entirely complementary to the interior profile **118** of the second channel **102**, with the exception of assembly clearances that may exist between the interior profiles of the first and second channels **94, 102** and the contoured profiles **174** of the first and second contoured profiles. Multiple spline joints **58** can then be assembled around the side walls **26, 30**, and front wall **34** of the trailer **10** in a similar manner to connect multiple wall panels **42** together. In some constructions, every joint between adjacent pairs of wall panels **42** throughout the entire trailer **10** is made by a spline joint **58** as described herein.

[0045] As mentioned above, in some embodiments, the first and second side edges **158, 162** of the wall panels **42** include a concavity **178** in the contoured profile **174**. When the spline joint **58** is assembled, the sides **122C** of the interior profiles **118** of respective first and second channels **94, 102** close the concavity **178**. Once the first wall panel **42** has been secured to the second wall panel **42**, adhesive can be applied to the concavities **178** on both the contoured profiles **174**. The adhesive fills the concavities **178** for the entire length of the spline **54**, or portions thereof, to bond the surface of the concavity **178** with the sides **122A-D** of the interior profiles **118**. The interior profiles **118** are completely filled and have no voids, although in this construction the protrusions **174** along with the adhesive cooperatively fill the interior profiles **118**.

[0046] It should be noted that each of the protrusions **170** on the first and second side edges **158, 162** cannot be forced in a direction perpendicular to the length **L1** of the spline **54, 130, 140** into the respective first and second channels **94, 102** of the spline **54, 130, 140** in order to form the spline joint **58** therebetween. In other words, the spline joints **58** are not capable of being established by snapping or clicking into place via elastic deformation of one or both mating components, and the protrusions **170** will only fit into respective first and second channels **94, 102** if the spline **54, 130, 140** is slid axially onto the first and second side edges **158, 162** of the wall panels **42**.

[0047] FIG. **15** illustrates a spline joint **58** including a spline **54** without the central channel **134**. The spline joint **58** includes a first side edge **158** of a first wall panel **42** received within a first channel **94** and a second side edge **162** of a second wall panel **42** received within a second channel **102**. FIG. **16** illustrates a spline joint **58** including a spline **130** with the central channel **134**. The spline joint **58** also includes a first side edge **158** of a first wall panel **42** received



within a first channel **94** and a second side edge **162** of a second wall panel **42** received within a second channel **102**.

**[0048]** As discussed earlier, the wall panels **42** of the trailers **10** may span in a multitude of ways around the side walls **26**, **30**, and front wall **34** of the trailer **10**. For example, a spline joint **130** may join two wall panels **42** on the first side wall **26** or the second side wall **30** of the trailer **10** (FIG. **21**) or a spline joint **130** may join two wall panels **42** on the front wall **34** of the trailer **10** (FIG. **22**). As such, the spline joints **58** may be spaced around the side walls **26**, **30**, and front wall **34** of the trailer **10** in a variety of ways. In addition, the side walls **26**, **30**, and front wall **34** of the trailer **10** may meet in different ways to form different kinds of corners (e.g., beveled **182**, square **186**, rounded **190**, etc.). For example, as shown in FIG. **17**, a spline joint **58** including a spline **130** with the central channel **134** may be positioned on either the first or second side wall **26**, **30** of the trailer **10** next to a beveled corner **182** connecting a wall panel **42** on the front wall **34** to a wall panel **42** on one of the side walls **26**, **30**. With reference to FIG. **18**, a spline joint **58** including a spine **130** may be positioned on a beveled corner **182** connecting a wall panel **42** on the front wall **34** to a wall panel **42** on one of the side walls **26**, **30**. Another example of a spline joint **58** with a spline **130**, as shown in FIG. **19**, may be positioned on either the first or second side wall **26**, **30** of the trailer **10** next to a square corner **186** connecting a wall panel **42** on one of the side walls **26**, **30** to a wall panel **42** on the front wall **34**. A further example, as shown in FIG. **20**, a spline joint **58** including the spline **130** with the central channel **134** may be positioned on either the first or second sidewalls **26**, **30** of the trailer **10** next to a rounded corner **190** connecting a wall panel **42** on one of the side walls **26**, **30** to a wall panel **42** on the front wall **34**. Although FIGS. **17-22** illustrate spline joints **58** including the spline **130** of FIGS. **7** and **8** and no concavities **178**, any or all of these joints can also be made with other embodiments disclosed herein, or various feature combinations thereof (e.g., with or without the central channel **134** and with or without the concavities **178** in any particular combination).

**[0049]** FIG. **23** illustrates the interior **22** of the trailer **10** with all the wall panels **42** secured. The spline joints **58** are spaced around the first side wall **26**, the second side wall **30**, and the front wall **34**. The splines **140** of the spline joints **58** all include logistic slots **142** that are configured to support fastening of additional structures inside the interior **22** of the trailer **10**. In other embodiments, only selected splines **140**, or none of the spline **140**, include logistic slots **142**.

**[0050]** In some embodiments, the spline **54**, **130**, **140** of the spline joint **58** does not extend the entire length between the top edge **150** and bottom edge **154** of the first and second wall panels **42**. The spline **54**, **130**, **140** may only extend partially between the top and bottom edges **150**, **154** of the first and second wall panels **42** to allow space for additional fastening means above and below the spline joint **58**. In further embodiments, the spline **54**, **130**, **140** may extend further than the first and second wall panels **42** to establish direct or indirect engagement with the top and bottom rails **78**, **82**.

**[0051]** Various features and advantages of the invention are set forth in the following claims.

What is claimed is:

1. A container defining a cargo receiving interior defined by a plurality of panels, the container comprising:

- a first panel having a first edge, the first edge having a first protrusion with a first contoured profile, the first contoured profile having at least one projection;
  - a second panel having a second edge, the second edge having a second protrusion with a second contoured profile, the contoured profile having at least one projection; and
  - a spline including a first channel that defines a rectangular recess with an interior profile at least partially closed on four sides, and a second channel separate from the first channel that defines a rectangular recess with an interior profile at least partially closed on four sides, wherein the first channel of the spline receives the first protrusion of the first panel such that the first contoured profile contacts all four sides of the rectangular recess of the first channel, and wherein the second channel of the spline receives the second protrusion of the second panel such that the second contoured profile contacts all four sides of the rectangular recess of the second channel.
2. The container of claim 1, wherein the first panel further includes a mid-section extending from the first edge and the second panel further includes a mid-section extending from the second edge, wherein the first edge has a greater thickness than the thickness of the mid-section of the first panel and the second edge has a greater thickness than the thickness of the mid-section of the second panel.
3. The container of claim 1, wherein the rectangular recess of each of the first and second channels includes a male projection having both a flat side and a curved side opposite the flat side.
4. The container of claim 1, wherein the first and second protrusions of the first and second edges of the first and second panels are offset inward toward an interior of the container from a plane that is defined by an interior surface of each of the first and second panels.
5. The container of claim 1, wherein the first contoured profile extends an entire length of the first edge from a top edge of the first panel to a bottom edge of the first panel, and wherein the second contoured profile extends an entire length of the second edge from a top edge of the second panel to a bottom edge of the second panel.
6. The container of claim 1, wherein the first and second channels of the spline open in opposite directions.
7. The container of claim 6, wherein the first and second channels of the spline are symmetrical to each other about a plane that extends through the spline.
8. The container of claim 1, wherein the spline further includes a central channel positioned between the first channel and the second channel.
9. The container of claim 8, wherein the spline further includes slots through an interior wall of the central channel, the interior wall facing an interior of the container.
10. A container defining a cargo receiving interior defined by a plurality of panels, the container comprising:
- a first panel having a first edge, the first edge having a first protrusion with a first contoured profile, the first contoured profile having at least one projection;
  - a second panel having a second edge, the second edge having a second protrusion with a second contoured profile, the contoured profile having at least one projection; and
  - a spline including first and second separate channels, the channels defining respective interior profiles, wherein

- the first channel receives the first protrusion of the first panel such that the first contoured profile is complementary to a portion of the interior profile of the first channel, and wherein the second channel receives the second protrusion of the second panel such that the second contoured profile is complementary to a portion of the interior profile of the second channel,
- wherein the interior profiles of the first and second channels include respective male projections extending into the respective first and second channels, each male projection having both a flat side and a curved side opposite the flat side.
- 11.** The container of claim **10**, wherein the first panel further includes a mid-section extending from the first edge and the second panel further includes a mid-section extending from the second edge, wherein the first edge has a greater thickness than the thickness of the mid-section of the first panel and the second edge has a greater thickness than the thickness of the mid-section of the second panel.
- 12.** The container of claim **10**, wherein each of the first and second channels of the spline defines a rectangular recess at least partially closed on four sides.
- 13.** The container of claim **10**, wherein the first and second protrusions of the first and second edges of the first and second panels are offset inward toward an interior of the container from a plane that is defined by an interior surface of each of the first and second panels.
- 14.** The container of claim **10**, wherein the first contoured profile extends an entire length of the first edge from a top edge of the first panel to a bottom edge of the first panel, and wherein the second contoured profile extends an entire length of the second edge from a top edge of the second panel to a bottom edge of the second panel.
- 15.** The container of claim **10**, wherein the first and second channels of the spline open in opposite directions.
- 16.** The container of claim **15**, wherein the first and second channels of the spline are symmetrical to each other about a plane that extends through the spline.
- 17.** The container of claim **10**, wherein the spline further includes a central channel positioned between the first channel and the second channel.
- 18.** The container of claim **17**, wherein the spline further includes slots through an interior wall of the central channel, the interior wall facing an interior of the container.
- 19.** A container defining a cargo receiving interior defined by a plurality of panels, the container comprising:
- a first panel having a first edge, the first edge having a first protrusion with a first contoured profile, the first contoured profile having at least one projection, wherein the first panel further includes a mid-section extending from the first edge;
  - a second panel having a second edge, the second edge having a second protrusion with a second contoured profile, the contoured profile having at least one projection, wherein the second panel further includes a mid-section extending from the second edge; and
- a spline including first and second separate channels, the channels defining respective interior profiles, wherein the first channel receives the first protrusion of the first panel, and wherein the second channel receives the second protrusion of the second panel,
  - wherein the first channel has an opening that opens in a direction perpendicular to the mid-section of the first panel, and the second channel has an opening that opens in a direction perpendicular to the mid-section of the second panel,
  - wherein the first protrusion of the first panel is oversized with respect to the opening of the first channel to preclude passage of the first protrusion through the opening of the first channel, and the second protrusion of the second panel is oversized with respect to the opening of the second channel to preclude passage of the second protrusion through the opening of the second channel.
- 20.** The container of claim **19**, wherein each of the first and second channels of the spline includes a male projection having both a flat side and a curved side opposite the flat side.
- 21.** The container of claim **19**, wherein each of the first and second channels of the spline defines a rectangular recess at least partially closed on four sides,
- wherein the first channel of the spline receives the first protrusion of the first panel such that the first contoured profile contacts all four sides of the rectangular recess of the first channel, and
  - wherein the second channel of the spline receives the second protrusion of the second panel such that the second contoured profile contacts all four sides of the rectangular recess of the second channel.
- 22.** The container of claim **19**, wherein the first and second protrusions of the first and second edges of the first and second panels are offset inward toward an interior of the container from a plane that is defined by an interior surface of each of the first and second panels.
- 23.** The container of claim **19**, wherein the first contoured profile extends an entire length of the first edge from a top edge of the first panel to a bottom edge of the first panel, and wherein the second contoured profile extends an entire length of the second edge from a top edge of the second panel to a bottom edge of the second panel.
- 24.** The container of claim **19**, wherein the first and second channels of the spline open in opposite directions.
- 25.** The container of claim **24**, wherein the first and second channels of the spline are symmetrical to each other about a plane that extends through the spline.
- 26.** The container of claim **19**, wherein the spline further includes a central channel positioned between the first channel and the second channel.
- 27.** The container of claim **26**, wherein the spline further includes slots through an interior wall of the central channel, the interior wall facing an interior of the container.