



US008197467B2

(12) **United States Patent**
Heaton et al.

(10) **Patent No.:** **US 8,197,467 B2**
(45) **Date of Patent:** **Jun. 12, 2012**

(54) **MODULAR, REDUCED-PRESSURE, WOUND-CLOSURE SYSTEMS AND METHODS**

2,632,443 A 3/1953 Leshner
2,682,873 A 7/1954 Evans et al.
2,910,763 A 11/1959 Lauterbach
2,969,057 A 1/1961 Simmons
3,066,672 A 12/1962 Crosby, Jr. et al.

(75) Inventors: **Keith Patrick Heaton**, Poole (GB);
Christopher Guy Coward, Wareham (GB);
Colin John Hall, Poole (GB)

(Continued)

FOREIGN PATENT DOCUMENTS

(73) Assignee: **KCI Licensing, Inc.**, San Antonio, TX (US)

AU 550575 A1 8/1982
(Continued)

(*) Notice: Subject to any disclaimer, the term of this patent is extended or adjusted under 35 U.S.C. 154(b) by 315 days.

OTHER PUBLICATIONS

(21) Appl. No.: **12/467,168**

N.A. Bagautdinov, "Variant of External Vacuum Aspiration in the Treatment of Purulent Diseases of the Soft Tissues," *Current Problems in Modern Clinical Surgery: Interdepartmental Collection*, edited by V. Ye Volkov et al. (Chuvashia State University, Cheboksary, U.S.S.R. 1986);pp. 94-96.

(22) Filed: **May 15, 2009**

(Continued)

(65) **Prior Publication Data**

US 2010/0106187 A1 Apr. 29, 2010

Related U.S. Application Data

(60) Provisional application No. 61/109,410, filed on Oct. 29, 2008, provisional application No. 61/109,486, filed on Oct. 29, 2008, provisional application No. 61/109,390, filed on Oct. 29, 2008, provisional application No. 61/109,448, filed on Oct. 29, 2008.

Primary Examiner — Tatyana Zalukaeva

Assistant Examiner — Benedict L Hanrahan

(74) *Attorney, Agent, or Firm* — SNR Denton US, LLP

(51) **Int. Cl.**
A61M 1/00 (2006.01)

(52) **U.S. Cl.** **604/540**; 604/317

(58) **Field of Classification Search** 604/19, 604/289, 290, 304-317, 319, 327, 540, 541, 604/543; 602/2, 42; 601/6

See application file for complete search history.

(57) **ABSTRACT**

A modular, reduced-pressure, wound-closure system for providing a closing force on a surface wound includes a flexible strap operable to be formed into a closed loop inbound and around the surface wound and a plurality of modular closing members coupled to the flexible strap. A reduced-pressure source is fluidly coupled to the plurality of modular closing members. The modular closing members are operable to generate a closing force on the surface wound. A portion of the modular closing members are releasably attached to the patient's epidermis proximate the surface wound and another portion are attached to the flexible strap. A reduced pressure from the reduced-pressure source is delivered to each modular closing member to generate the closing force on the surface wound. Methods and other systems are presented.

(56) **References Cited**

U.S. PATENT DOCUMENTS

1,355,846 A 10/1920 Rannells
2,547,758 A 4/1951 Keeling

19 Claims, 5 Drawing Sheets

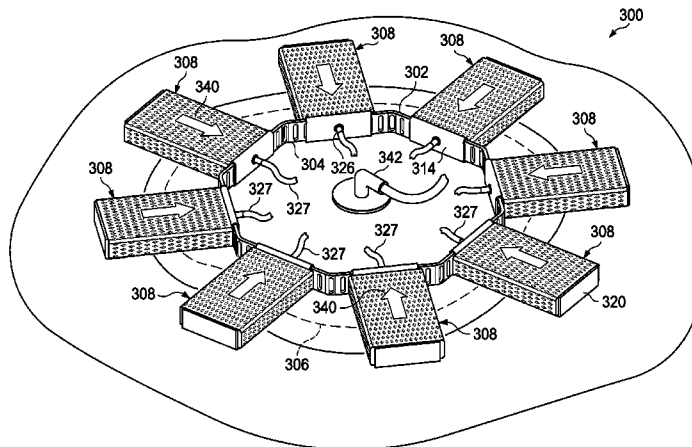

U.S. PATENT DOCUMENTS					
3,367,332 A	2/1968	Groves	5,167,613 A	12/1992	Karami et al.
3,520,300 A	7/1970	Guiles, Jr.	5,176,663 A	1/1993	Svedman et al.
3,556,101 A	1/1971	Economou	5,192,266 A	3/1993	Wilk
3,568,675 A	3/1971	Harvey	5,215,522 A	6/1993	Page et al.
3,648,692 A	3/1972	Wheeler	5,232,453 A	8/1993	Plass et al.
3,682,180 A	8/1972	McFarlane	5,261,893 A	11/1993	Zamierowski
3,826,254 A	7/1974	Mellor	5,278,100 A	1/1994	Doan et al.
3,830,238 A	8/1974	Kurtz et al.	5,279,550 A	1/1994	Habib et al.
4,080,970 A	3/1978	Miller	5,298,015 A	3/1994	Komatsuzaki et al.
4,096,853 A	6/1978	Weigand	5,342,376 A	8/1994	Ruff
4,139,004 A	2/1979	Gonzalez, Jr.	5,344,415 A	9/1994	DeBusk et al.
4,165,748 A	8/1979	Johnson	5,358,494 A	10/1994	Svedman
4,184,510 A	1/1980	Murry et al.	5,437,622 A	8/1995	Carion
4,233,969 A	11/1980	Lock et al.	5,437,651 A	8/1995	Todd et al.
4,245,630 A	1/1981	Lloyd et al.	5,437,683 A	8/1995	Neumann et al.
4,250,882 A	2/1981	Adair	5,441,481 A	8/1995	Mishra et al.
4,256,109 A	3/1981	Nichols	5,443,848 A	8/1995	Kramer et al.
4,261,363 A	4/1981	Russo	5,466,231 A	11/1995	Cercone et al.
4,275,721 A	6/1981	Olson	5,484,399 A	1/1996	Diresta et al.
4,284,079 A	8/1981	Adair	5,484,428 A	1/1996	Drainvill et al.
4,294,240 A	10/1981	Thill	5,527,293 A	6/1996	Zamierowski
4,297,995 A	11/1981	Golub	5,549,584 A	8/1996	Gross
4,333,468 A	6/1982	Geist	5,556,375 A	9/1996	Ewall
4,346,711 A	8/1982	Agdanowski et al.	5,607,388 A	3/1997	Ewall
4,373,519 A	2/1983	Errede et al.	5,636,643 A	6/1997	Argenta et al.
4,382,441 A	5/1983	Svedman	5,637,103 A	6/1997	Kerwin et al.
4,392,853 A	7/1983	Muto	5,645,081 A	7/1997	Argenta et al.
4,392,858 A	7/1983	George et al.	5,662,598 A	9/1997	Tobin
4,419,097 A	12/1983	Rowland	5,701,917 A	12/1997	Khoury
4,430,084 A	2/1984	Deaton	5,792,173 A	8/1998	Breen et al.
4,465,485 A	8/1984	Kashmer et al.	5,893,368 A	4/1999	Sugerman
4,475,909 A	10/1984	Eisenberg	5,902,260 A	5/1999	Gilman et al.
4,480,638 A	11/1984	Schmid	5,938,626 A	8/1999	Sugerman
4,525,166 A	6/1985	Leclerc	6,042,539 A	3/2000	Harper et al.
4,525,374 A	6/1985	Vaillancourt	6,051,747 A	4/2000	Lindqvist et al.
4,540,412 A	9/1985	Van Overloop	6,071,267 A	6/2000	Zamierowski
4,543,100 A	9/1985	Brodsky	6,135,116 A	10/2000	Vogel et al.
4,548,202 A	10/1985	Duncan	6,174,306 B1	1/2001	Fleischmann
4,551,139 A	11/1985	Plaas et al.	6,241,747 B1	6/2001	Ruff
4,569,348 A	2/1986	Hasslinger	6,264,979 B1	7/2001	Svedman
4,605,399 A	8/1986	Weston et al.	6,287,316 B1	9/2001	Agarwal et al.
4,608,041 A	8/1986	Nielson	6,345,623 B1	2/2002	Heaton et al.
4,633,865 A	1/1987	Hengstberger et al.	6,383,162 B1	5/2002	Sugarbaker
4,640,688 A	2/1987	Hauser	6,458,109 B1	10/2002	Henley et al.
4,655,754 A	4/1987	Richmond et al.	6,488,643 B1	12/2002	Tumey et al.
4,664,662 A	5/1987	Webster	6,493,568 B1	12/2002	Bell et al.
4,710,165 A	12/1987	McNeil et al.	6,537,241 B1	3/2003	Odland
4,728,642 A	3/1988	Pawelchak et al.	6,553,998 B2	4/2003	Heaton et al.
4,733,659 A	3/1988	Edenbaum et al.	6,626,891 B2	9/2003	Ohmstede
4,743,232 A	5/1988	Kruger	6,685,681 B2	2/2004	Lockwood et al.
4,758,220 A	7/1988	Sundblom et al.	6,695,823 B1	2/2004	Line et al.
4,787,888 A	11/1988	Fox	6,752,794 B2	6/2004	Lockwood et al.
4,815,468 A	3/1989	Annand	6,814,079 B2	11/2004	Heaton et al.
4,825,866 A	5/1989	Pierce	6,855,135 B2	2/2005	Lockwood et al.
4,826,494 A	5/1989	Richmond et al.	6,936,037 B2	8/2005	Bubb et al.
4,838,883 A	6/1989	Matsuura	6,951,553 B2	10/2005	Bubb et al.
4,840,187 A	6/1989	Brazier	6,979,324 B2	12/2005	Bybordi et al.
4,844,072 A	7/1989	French et al.	7,105,001 B2	9/2006	Mandelbaum
4,863,449 A	9/1989	Therriault et al.	7,128,735 B2 *	10/2006	Weston 604/543
4,872,450 A	10/1989	Austad	7,195,624 B2	3/2007	Lockwood et al.
4,878,901 A	11/1989	Sachse	7,276,051 B1	10/2007	Henley et al.
4,897,081 A	1/1990	Poirier et al.	7,284,730 B2 *	10/2007	Walsh et al. 248/74.3
4,899,965 A	2/1990	Usui	7,322,971 B2	1/2008	Shehada
4,906,233 A	3/1990	Moriuchi et al.	7,338,482 B2	3/2008	Lockwood et al.
4,906,240 A	3/1990	Reed et al.	7,381,859 B2	6/2008	Hunt et al.
4,908,350 A	3/1990	Kramer et al.	7,476,205 B2	1/2009	Erdmann
4,919,654 A	4/1990	Kalt et al.	7,790,945 B1	9/2010	Watson, Jr.
4,941,882 A	7/1990	Ward et al.	7,951,100 B2	5/2011	Hunt
4,953,565 A	9/1990	Tachibana et al.	8,114,126 B2	2/2012	Heaton et al.
4,969,880 A	11/1990	Zamierowski	2002/0062097 A1	5/2002	Simpson
4,985,019 A	1/1991	Michelson	2002/0065494 A1	5/2002	Lockwood et al.
5,014,389 A	5/1991	Ogilvie et al.	2002/0077661 A1	6/2002	Saadat
5,037,397 A	8/1991	Kalt et al.	2002/0115951 A1	8/2002	Norstrem et al.
5,086,170 A	2/1992	Luheshi et al.	2002/0115956 A1	8/2002	Ross
5,092,858 A	3/1992	Benson et al.	2002/0120185 A1	8/2002	Johnson
5,100,396 A	3/1992	Zamierowski	2002/0143286 A1	10/2002	Tumey
5,134,994 A	8/1992	Say	2002/0161317 A1	10/2002	Risk et al.
5,149,331 A	9/1992	Ferdman et al.	2003/0208149 A1	11/2003	Coffey
			2004/0030304 A1	2/2004	Hunt et al.

2005/0085795	A1	4/2005	Lockwood
2005/0101922	A1	5/2005	Anderson et al.
2005/0131327	A1	6/2005	Lockwood et al.
2005/0222544	A1	10/2005	Weston
2005/0261642	A1	11/2005	Weston
2005/0273066	A1	12/2005	Wittmann
2006/0029650	A1	2/2006	Coffey
2006/0041247	A1	2/2006	Petrosenko et al.
2006/0079852	A1	4/2006	Bubb
2006/0189910	A1	8/2006	Johnson et al.
2007/0185426	A1	8/2007	Ambrosio et al.
2007/0282309	A1*	12/2007	Bengtson et al. 604/541
2007/0293830	A1	12/2007	Martin
2008/0058684	A1	3/2008	Ugander et al.
2008/0103462	A1	5/2008	Wenzel et al.
2008/0125687	A1	5/2008	Flick et al.
2008/0167593	A1	7/2008	Fleischmann
2008/0269658	A1	10/2008	Vinton et al.
2009/0099519	A1	4/2009	Kaplan
2010/0030132	A1	2/2010	Niezgoda et al.

FOREIGN PATENT DOCUMENTS

AU	745271	4/1999
AU	755496	2/2002
CA	2005436	6/1990
CA	2 303 085	3/1999
DE	26 40 413 A1	3/1978
DE	2754775 A1	6/1979
DE	43 06 478 A1	9/1994
DE	295 04 378 U1	10/1995
DE	20115990 U1	12/2001
DE	69806842 T2	1/2003
DE	60118546 T2	8/2006
DE	102006032870	1/2008
EP	0100148 A1	2/1984
EP	0117632 A2	9/1984
EP	0161865 A2	11/1985
EP	271491 B1	6/1988
EP	0358302 A2	3/1990
EP	0506992	10/1992
EP	0555293	8/1993
EP	0777504	6/1997
EP	0 853 950 B1	10/2002
EP	1284777	2/2003
EP	1 088 569 B1	8/2003
EP	1018967 B1	8/2004
EP	0 688 189 B2	6/2005
EP	0 620 720 B2	11/2006
GB	692578	6/1953
GB	2058227 A	4/1981
GB	2 195 255 A	4/1988
GB	2 197 789 A	6/1988
GB	2 220 357 A	1/1990
GB	2 235 877 A	3/1991
GB	2 333 965 A	8/1999
GB	2342584 A	4/2000
GB	2 329 127 B	8/2000
GB	2365350	2/2002
JP	3056429 U	5/1991
JP	4129536	4/1992
SG	71559	4/2002
WO	WO 80/02182	10/1980
WO	WO 87/01027 A1	2/1987
WO	WO 87/04626	8/1987
WO	WO 90/10424	9/1990
WO	WO 92/07519 A1	5/1992
WO	WO 93/09727	5/1993
WO	WO 94/20041	9/1994
WO	WO 96/05873	2/1996
WO	WO 96/34636 A	11/1996
WO	WO 97/18007	5/1997
WO	WO 99/01173 A1	1/1999
WO	WO 99/13793	3/1999
WO	WO 00/07653 A1	2/2000
WO	WO 00/42958 A1	7/2000
WO	WO 00/57794 A1	10/2000
WO	WO 00/59418 A1	10/2000
WO	WO 00/59424 A1	10/2000
WO	WO 01/34223 A1	5/2001

WO	WO 01/71231 A1	9/2001
WO	WO 01/85248 A	11/2001
WO	WO 01/89431 A1	11/2001
WO	WO 03/057307 A1	7/2003
WO	WO 03/086232	10/2003
WO	WO 2006/048246 A1	5/2006
WO	WO 2006/114637 A2	11/2006
WO	WO 2007/031762 A	3/2007
WO	WO 2007/041642 A	4/2007
WO	WO 2007/109209 A2	9/2007
WO	WO 2007/133618 A2	11/2007
WO	WO 2008/014358 A2	1/2008
WO	WO 2008/040020 A	4/2008
WO	WO 2008/041926 A1	4/2008
WO	WO 2008/103625 A2	8/2008

OTHER PUBLICATIONS

Louis C. Argenta, MD and Michael J. Morykwas, PhD; "Vacuum-Assisted Closure: A New Method for Wound Control and Treatment: Clinical Experience"; *Annals of Plastic Surgery*, vol. 38, No. 6, Jun. 1997; pp. 563-576.

Susan Mendez-Eastmen, RN; "When Wounds Won't Heal" *RN* Jan. 1998, vol. 61 (1); Medical Economics Company, Inc., Montvale, NJ, USA; pp. 20-24.

James H. Blackburn, II, MD, et al; "Negative-Pressure Dressings as a Bolster for Skin Grafts"; *Annals of Plastic Surgery*, vol. 40, No. 5, May 1998, pp. 453-457.

John Masters; "Reliable, Inexpensive and Simple Suction Dressings"; Letter to the Editor, *British Journal of Plastic Surgery*, 1998, vol. 51 (3), p. 267; Elsevier Science/The British Association of Plastic Surgeons, UK.

S.E. Greer, et al "The Use of Subatmospheric Pressure Dressing Therapy to Close Lymphocutaneous Fistulas of the Groin" *British Journal of Plastic Surgery* (2000), 53, pp. 484-487.

George V. Letsou, MD., et al; "Stimulation of Adenylate Cyclase Activity in Cultured Endothelial Cells Subjected to Cyclic Stretch"; *Journal of Cardiovascular Surgery*, 31, 1990, pp. 634-639.

Orringer, Jay, et al; "Management of Wounds in Patients with Complex Enterocutaneous Fistulas"; *Surgery, Gynecology & Obstetrics*, Jul. 1987, vol. 165, pp. 79-80.

International Search Report for PCT International Application PCT/GB95/01983; Nov. 23, 1995.

PCT International Search Report for PCT International Application PCT/GB98/02713; Jan. 8, 1999.

PCT Written Opinion; PCT International Application PCT/GB98/02713; Jun. 8, 1999.

PCT International Examination and Search Report, PCT International Application PCT/GB96/02802; Jan. 15, 1998 & Apr. 29, 1997.

PCT Written Opinion, PCT International Application PCT/GB96/02802; Sep. 3, 1997.

Dattilo, Philip P., JR., et al; "Medical Textiles: Application of an Absorbable Barbed Bi-directional Surgical Suture"; *Journal of Textile and Apparel, Technology and Management*, vol. 2, Issue 2, Spring 2002, pp. 1-5.

Kostyuchenok, B.M., et al; "Vacuum Treatment in the Surgical Management of Purulent Wounds"; *Vestnik Khirurgi*, Sep. 1986, pp. 18-21 and 6 page English translation thereof.

Davydov, Yu. A., et al; "Vacuum Therapy in the Treatment of Purulent Lactation Mastitis"; *Vestnik Khirurgi*, May 14, 1986, pp. 66-70, and 9 page English translation thereof.

Yusupov, Yu. N., et al; "Active Wound Drainage", *Vestnik Khirurgi*, vol. 138, Issue 4, 1987, and 7 page English translation thereof.

Davydov, Yu. A., et al; "Bacteriological and Cytological Assessment of Vacuum Therapy for Purulent Wounds"; *Vestnik Khirurgi*, Oct. 1988, pp. 48-52, and 8 page English translation thereof.

Davydov, Yu. A., et al; "Concepts for the Clinical-Biological Management of the Wound Process in the Treatment of Purulent Wounds by Means of Vacuum Therapy"; *Vestnik Khirurgi*, Jul. 7, 1980, pp. 132-136, and 8 page English translation thereof.

Chariker, Mark E., M.D., et al; "Effective Management of incisional and cutaneous fistulae with closed suction wound drainage"; *Contemporary Surgery*, vol. 34, Jun. 1989, pp. 59-63.

- Egnell Minor, Instruction Book, First Edition, 300 7502, Feb. 1975, pp. 24.
- Egnell Minor: Addition to the Users Manual Concerning Overflow Protection—Concerns all Egnell Pumps, Feb. 3, 1983, pp. 2.
- Svedman, P.: “Irrigation Treatment of Leg Ulcers”, *The Lancet*, Sep. 3, 1983, pp. 532-534.
- Chinn, Steven D. et al.: “Closed Wound Suction Drainage”, *The Journal of Foot Surgery*, vol. 24, No. 1, 1985, pp. 76-81.
- Arnljots, Björn et al.: “Irrigation Treatment in Split-Thickness Skin Grafting of Intractable Leg Ulcers”, *Scand J. Plast Reconstr. Surg.*, No. 19, 1985, pp. 211-213.
- Svedman, P.: “A Dressing Allowing Continuous Treatment of a Biosurface”, *IRCS Medical Science: Biomedical Technology, Clinical Medicine, Surgery and Transplantation*, vol. 7, 1979, p. 221.
- Svedman, P. et al.: “A Dressing System Providing Fluid Supply and Suction Drainage Used for Continuous or Intermittent Irrigation”, *Annals of Plastic Surgery*, vol. 17, No. 2, Aug. 1986, pp. 125-133.
- K.F. Jeter, T.E. Tintle, and M. Chariker, “Managing Draining Wounds and Fistulae: New and Established Methods,” *Chronic Wound Care*, edited by D. Krasner (Health Management Publications, Inc., King of Prussia, PA 1990), pp. 240-246.
- G. Živadinović, V. Đukić, Ž. Maksimović, Đ. Radak, and P. Peška, “Vacuum Therapy in the Treatment of Peripheral Blood Vessels,” *Timok Medical Journal* 11 (1986), pp. 161-164.
- F.E. Johnson, “An Improved Technique for Skin Graft Placement Using a Suction Drain,” *Surgery, Gynecology, and Obstetrics* 159 (1984), pp. 584-585.
- A.A. Safronov, Dissertation Abstract, *Vacuum Therapy of Trophic Ulcers of the Lower Leg with Simultaneous Autoplasty of the Skin* (Central Scientific Research Institute of Traumatology and Orthopedics, Moscow, U.S.S.R. 1967).
- M. Schein, R. Saadia, J.R. Jamieson, and G.A.G. Decker, “The ‘Sandwich Technique’ in the Management of the Open Abdomen,” *British Journal of Surgery* 73 (1986), pp. 369-370.
- D.E. Tribble, An Improved Sump Drain-Irrigation Device of Simple Construction, *Archives of Surgery* 105 (1972) pp. 511-513.
- M.J. Morykwas, L.C. Argenta, E.I. Shelton-Brown, and W. McGuirt, “Vacuum-Assisted Closure: A New Method for Wound Control and Treatment: Animal Studies and Basic Foundation,” *Annals of Plastic Surgery* 38 (1997), pp. 553-562 (Morykwas I).
- C.E. Tennants, “The Use of Hypermia in the Postoperative Treatment of Lesions of the Extremities and Thorax,” *Journal of the American Medical Association* 64 (1915), pp. 1548-1549.
- Selections from W. Meyer and V. Schmieden, *Bier’s Hyperemic Treatment in Surgery, Medicine, and the Specialties: A Manual of Its Practical Application*, (W.B. Saunders Co., Philadelphia, PA 1909), pp. 17-25, 44-64, 90-96, 167-170, and 210-211.
- V.A. Solovev et al., Guidelines, The Method of Treatment of Immature External Fistulas in the Upper Gastrointestinal Tract, editor-in-chief Prov. V.I. Parahonyak (S.M. Kirov Gorky State Medical Institute, Gorky, U.S.S.R. 1987) (“Solovev Guidelines”).
- V.A. Kuznetsov & N.A. Bagautdinov, “Vacuum and Vacuum-Sorption Treatment of Open Septic Wounds,” in II All-Union Conference on Wounds and Wound Infections: Presentation Abstracts, edited by B.M. Kostyuchenok et al. (Moscow, U.S.S.R. Oct. 28-29, 1986) pp. 91-92 (“Bagautdinov II”).
- V.A. Solovev, Dissertation Abstract, Treatment and Prevention of Suture Failures after Gastric Resection (S.M. Kirov Gorky State Medical Institute, Gorky, U.S.S.R. 1988) (“Solovev Abstract”).
- The V.A.C. TM Vacuum Assisted Closure, Assisting in Wound Closure, Brochure, Jan. 1996, 5 pages, 1-A-042, KCI®, San Antonio, Texas.
- Argenta et al.: “The V.A.C. TM, Case Study #4”, Case Study, Mar. 1995, 1 page, 35-D-004, KCI®, San Antonio, Texas.
- Argenta et al.: “The V.A.C. TM, Case Study #3”, Case Study, Mar. 1995, 1 page, 35-D-003, KCI®, San Antonio, Texas.
- “The V.A.C. ® Operations Summary, The V.A.C. ® Wound Closure System Applications”, Brochure, Mar. 1997, 4 pages, 1-A-060, KCI®, San Antonio, Texas.
- “The V.A.C. ® Operations Summary, The V.A.C. ® Wound Closure System Applications”, Brochure, Mar. 1999, 2 pages, 1-A-060, KCI®, San Antonio Texas.
- Argenta et al.: “V.A.C. ® Wound Closure Device Case Study #3”, Case Study, Apr. 1998, 1 page, 35-D-003, KCI®, San Antonio, Texas.
- Argenta et al.: “V.A.C. ® Wound Closure Device Case Study #1”, Case Study, Apr. 1998, 1 page, 35-D-001, KCI®, San Antonio, Texas.
- The V.A.C.® Case Study #8, Case Study, Jun. 1996, 2 pages, 35-D-008, KCI®, San Antonio, Texas.
- The V.A.C.® Case Study #7, Case Study, Jun. 1996, 2 pages, 35-D-007, KCI®, San Antonio, Texas.
- The V.A.C.® Case Study #6, Case Study, Jun. 1996, 2 pages, 35-D-006, KCI®, San Antonio, Texas.
- The V.A.C.® Case Study #9, Case Study, Jun. 1996, 2 pages, 35-D-009, KCI®, San Antonio, Texas.
- The V.A.C.® Case Study #5, Case Study, Aug. 1994, 2 pages, 35-D-005, KCI®, San Antonio, Texas.
- The V.A.C.® Case Study #4, Case Study, Aug. 1994, 2 pages, 35-D-004, KCI®, San Antonio, Texas.
- The V.A.C.® Case Study #3, Case Study, Aug. 1994, 2 pages, 35-D-003, KCI®, San Antonio, Texas.
- The V.A.C.® Case Study #2, Case Study, Aug. 1994, 2 pages, 35-D-002, KCI®, San Antonio, Texas.
- The V.A.C.® Case Study #1, Case Study, Aug. 1994, 2 pages, 35-D-001, KCI®, San Antonio, Texas.
- Ex parte Quayle Office Action dated Feb. 7, 2005 for U.S. Appl. No. 10/275,671.
- Amendment filed Apr. 8, 2005 for U.S. Appl. No. 10/275,671.
- Non-Final Office Action dated Jun. 27, 2005 for U.S. Appl. No. 10/275,671.
- Response filed Oct. 19, 2005 for U.S. Appl. No. 10/275,671.
- Non-Final Office Action dated Jan. 10, 2006 for U.S. Appl. No. 10/275,671.
- Response filed Jul. 10, 2006 for U.S. Appl. No. 10/275,671.
- Supplemental Amendment filed Aug. 10, 2006 for U.S. Appl. No. 10/275,671.
- Final Office Action dated Apr. 17, 2007 for U.S. Appl. No. 10/275,671.
- Response filed Jun. 12, 2007 for U.S. Appl. No. 10/275,671.
- Advisory Action dated Jul. 11, 2007 for U.S. Appl. No. 10/275,671.
- Response filed Aug. 17, 2007 for U.S. Appl. No. 10/275,671.
- Non-Final Office Action dated Sep. 5, 2007 for U.S. Appl. No. 10/275,671.
- Response filed Sep. 5, 2007 for U.S. Appl. No. 10/275,671.
- Notice of Allowance and Fee(s) Due dated Feb. 4, 2008 for U.S. Appl. No. 10/275,671.
- Restriction Requirement date mailed Nov. 10, 2009 for U.S. Appl. No. 12/127,668.
- Response filed Dec. 10, 2009 for U.S. Appl. No. 12/127,668.
- Office Action date mailed Mar. 23, 2010 for U.S. Appl. No. 12/127,668.
- Response filed Jun. 23, 2010 for U.S. Appl. No. 12/127,668.
- Interview Summary date mailed May 25, 2010 for U.S. Appl. No. 12/466,973.
- Final Office Action date mailed Aug. 12, 2010 for U.S. Appl. No. 12/466,973.
- Final Office Action date mailed Sep. 16, 2010 for U.S. Appl. No. 12/127,668.
- Meyer et al, “A new abdominal drain for overflowing lavage in instances of severe pancreatitis with persistent peritoneal contamination”, *Surg. Gynecol Obstet.* Sep. 1987: 165(3): 271-3.
- Poritz, “Percutaneous drainage and ileocectomy for spontaneous intraabdominal abscess in Chrohns Disease” *J. Gastrointest Surg.* Feb. 2007; 11(2): 204-8.
- Khurram et al, “Percutaneous postoperative intra-abdominal abscess drainage after elective colorectal surgery” *Tech Coloproctol* Dec. 2002; 6(3): 159-64.
- Reckard et al, “Management of Intraabdominal Hypertension by Percutaneous Catheter Drainage” *Journal of Vascular Interventional Journal of Vascular Interventional Radiology*, vol. 16, Issue 7, pp. 1019-1021.
- Latenser et al, “A Pilot Study Comparing Percutaneous Decompression with decompressive laparotomy for acute abdominal compartment syndrome in thermal injury”, *J Burn Care & Rehab*, 23(3): 190-195.

- Kubiak et al, "Reduced intra-peritoneal inflammation by negative pressure therapy moderates systemic inflammation in a porcine model of the abdominal compartment Syndrome (ACS)", *Critical Care I*, vol. 207, No. 3S, Sep. 2008, S34-35.
- Kaplan, "Managing the open abdomen" *Ostomy Wound Management*, Jan. 2004; 50 1A supply; C2; 1-8.
- Kaplan et al, "Guidelines for the Management of the Open Abdomen" *Wounds* Oct. 2005; 17 (Suppl 1); S1S24.
- Garner et al, "Vacuum-assisted wound closure provides early fascial reapproximation in trauma patients with open abdomens" *The American Journal of Surgery*, Dec. 2001; 182 (6); 630-8.
- Barker et al, "Vacuum pack of technique of temporary abdominal closure; a 7-year experience with 112 patients" *J Trauma* Feb. 1, 2000; 48 (2): 201-6.
- Brock et al, "Temporary closure of open abdominal wounds: the vacuum pack" *Am Surg* Jan. 1995; 61(1): 30-5.
- Sherck et al, "Covering the 'open abdomen': a better technique", *Am Surg* Sep. 1998; 64(9): 854-7.
- Dubick et al, "Issues of concern regarding the use of hypertonic/hyperoncotic fluid resuscitation of hemorrhagic hypotension" *Shock*, Apr. 2006; 25(4): 321-8.
- Burdette, "Systemic Inflammatory Response Syndrome", <http://emedicine.medscape.com/article/168943-print>, Apr. 2007.
- Beamis Hydrorhobic Rigid Canisters—<http://www.bemishealthcare.com/docs/CanisterHydrophobic.pdf> (date unknown).
- Fink et al, "Textbook of Critical Care", 5th ed. (Philadelphia: Elsevier, 2005), 1933-1943.
- Smith & Nephew GmbH Nullity Action date mailed Sep. 10, 2010. Response filed Oct. 4, 2010 for U.S. Appl. No. 12/466,973.
- Advisory Action date mailed Oct. 12, 2010 for U.S. Appl. No. 12/466,973.
- RCE/Response filed Nov. 2, 2010 for U.S. Appl. No. 12/466,973.
- International Search Report and Written Opinion date mailed Nov. 5, 2009; PCT International Application No. PCT/US2009/044264.
- International Search Report and Written Opinion date mailed Nov. 18, 2009; PCT International Application No. PCT/US2009/044230.
- International Search Report and Written Opinion date mailed Sep. 17, 2009; PCT International Application No. PCT/US2009/044240.
- International Search Report and Written Opinion date mailed Nov. 5, 2009; PCT International Application No. PCT/US2009/044268.
- International Search Report and Written Opinion date mailed Oct. 6, 2009; PCT International Application No. PCT/US2009/044226.
- International Search Report and Written Opinion date mailed Oct. 15, 2009; PCT International Application No. PCT/US2009/044244.
- International Search Report and Written Opinion date mailed Oct. 6, 2009; PCT International Application No. PCT/US2009/044266.
- International Search Report and Written Opinion date mailed Nov. 5, 2009; PCT International Application No. PCT/US2009/044245.
- International Search Report and Written Opinion date mailed Oct. 23, 2009; PCT International Application No. PCT/US2009/044235.
- Response filed May 20, 2010 to Non-Final Action date mailed Mar. 5, 2010 in U.S. Appl. No. 12/466,973.
- Kubiak et al, "Peritoneal Negative Pressure Therapy Prevents Multiple Organ Injury in a Chronic Porcine Sepsis and Ischemia/Reperfusion Model", *Shock*, vol. 34, No. 5, pp. 525-534, 2010. Response filed Nov. 9, 2010 for U.S. Appl. No. 12/127,668.
- Notice of Allowance date mailed Dec. 6, 2010 for U.S. Appl. No. 12/127,668.
- Restriction Requirement dated Jan. 4, 2010 in U.S. Appl. No. 12/466,973.
- Response filed Jan. 21, 2010 to Restriction Requirement dated Jan. 4, 2010 in U.S. Appl. No. 12/466,973.
- Non-Final Action date mailed Mar. 5, 2010 in U.S. Appl. No. 12/466,973.
- Interview Summary date mailed Jan. 6, 2012 for U.S. Appl. No. 12/467,123.
- Response filed Jan. 9, 2012 for U.S. Appl. No. 12/467,123.
- Interview Summary date mailed Dec. 21, 2011 for U.S. Appl. No. 13/113,914.
- Non-Final Office Action and Interview Summary date mailed Sep. 6, 2011 for U.S. Appl. No. 12/467,064.
- Restriction Requirement date mailed Aug. 12, 2011 for U.S. Appl. No. 12/467,211.
- Restriction Requirement date mailed Jul. 21, 2011 for U.S. Appl. No. 12/467,123.
- Response filed for U.S. Appl. No. 12/467,123.
- Restriction Requirement date mailed Aug. 4, 2011 for U.S. Appl. No. 12/467,153.
- Response filed for U.S. Appl. No. 12/467,153.
- Restriction Requirement date mailed Jul. 27, 2011 for U.S. Appl. No. 12/467,199.
- Response filed for U.S. Appl. No. 12/467,199.
- Non-Final Office Action date mailed Sep. 8, 2011 for U.S. Appl. No. 12/467,203.
- Response filed Nov. 15, 2011 for U.S. Appl. 12/467,203.
- Interview Summary date mailed Nov. 17, 2011 for U.S. Appl. No. 12/467,203.
- Notice of Allowance date mailed Dec. 2, 2011 for U.S. Appl. No. 12/467,203.
- Response filed Sep. 9, 2011 for U.S. Appl. No. 12/467,211.
- Non-Final Office action date mailed Nov. 21, 2011 for U.S. Appl. No. 12/467,211.
- Non-Final Office Action date mailed Sep. 8, 2011 for U.S. Appl. No. 12/466,844.
- Response filed Nov. 18, 2011 for U.S. Appl. No. 12/466,844.
- Non-Final Office Action date mailed Sep. 14, 2011 for U.S. Appl. No. 13/113,914.
- Notice of Allowance date mailed Nov. 4, 2011 for U.S. Appl. No. 12/467,199.
- Response filed Nov. 15, 2011 for U.S. Appl. No. 12/467,064.
- Non-Final Office Action date mailed Nov. 4, 2011 for U.S. Appl. No. 12/467,123.
- Response filed Nov. 15, 2011 for U.S. Appl. No. 12/467,203.
- Response filed Dec. 14, 2011 for U.S. Appl. No. 13/113,914.
- Notice of Allowance date mailed Feb. 9, 2012 for U.S. Appl. No. 12/467,064.
- Response filed Feb. 8, 2012 for U.S. Appl. No. 12/467,211.
- Final Office Action date mailed Jan. 30, 2012 for U.S. Appl. No. 12/466,844.
- Interview Summary date mailed Feb. 29, 2012 for U.S. Appl. No. 12/466,844.
- Response filed Mar. 5, 2012 for U.S. Appl. No. 12/466,844.
- Notice of Allowance date mailed Feb. 24, 2012 for U.S. Appl. No. 13/113,914.
- Notice of Allowance date mailed Jan. 31, 2012 for U.S. Appl. No. 12/467,153.
- US 6,216,701, 04/2001, Heaton (withdrawn)

* cited by examiner

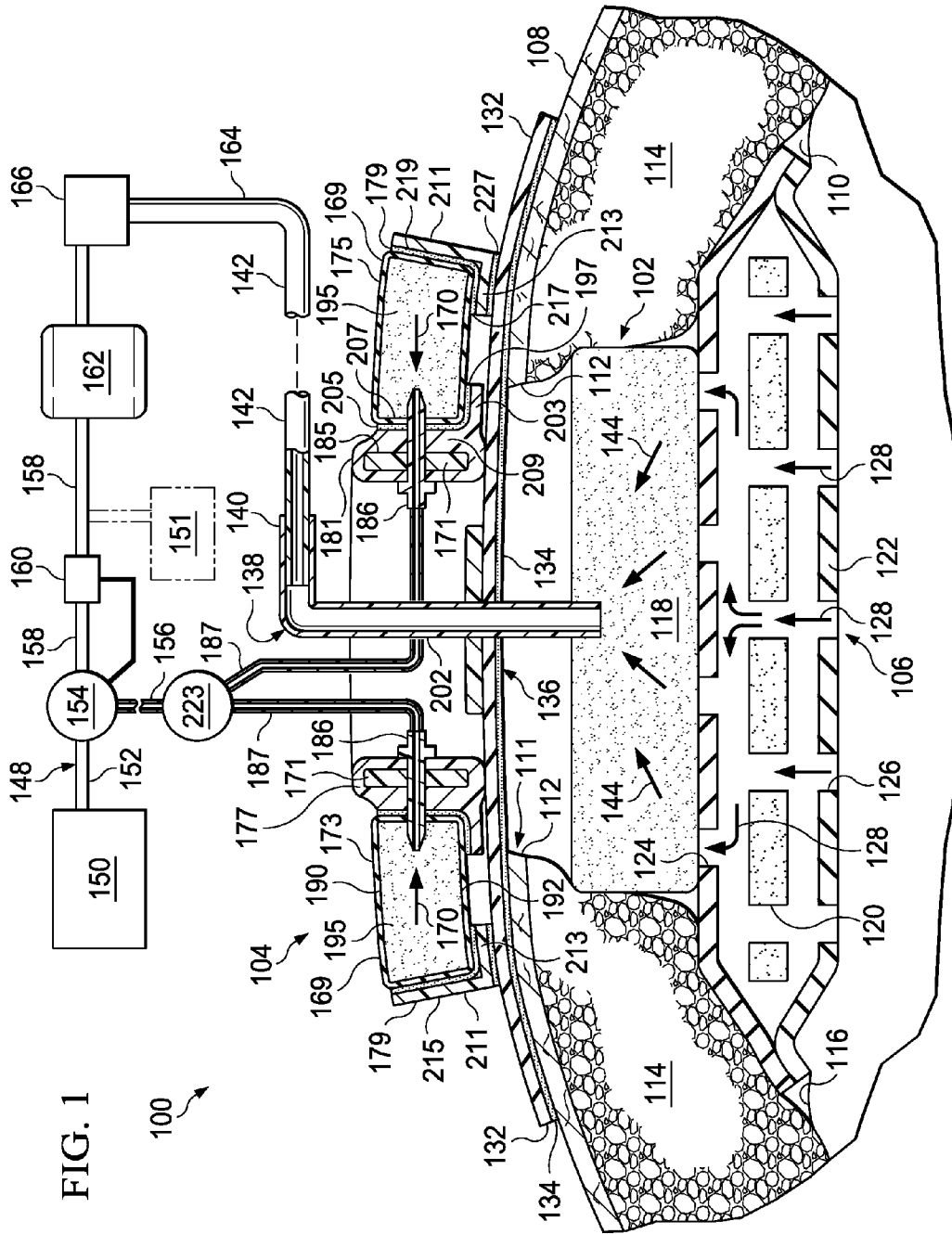
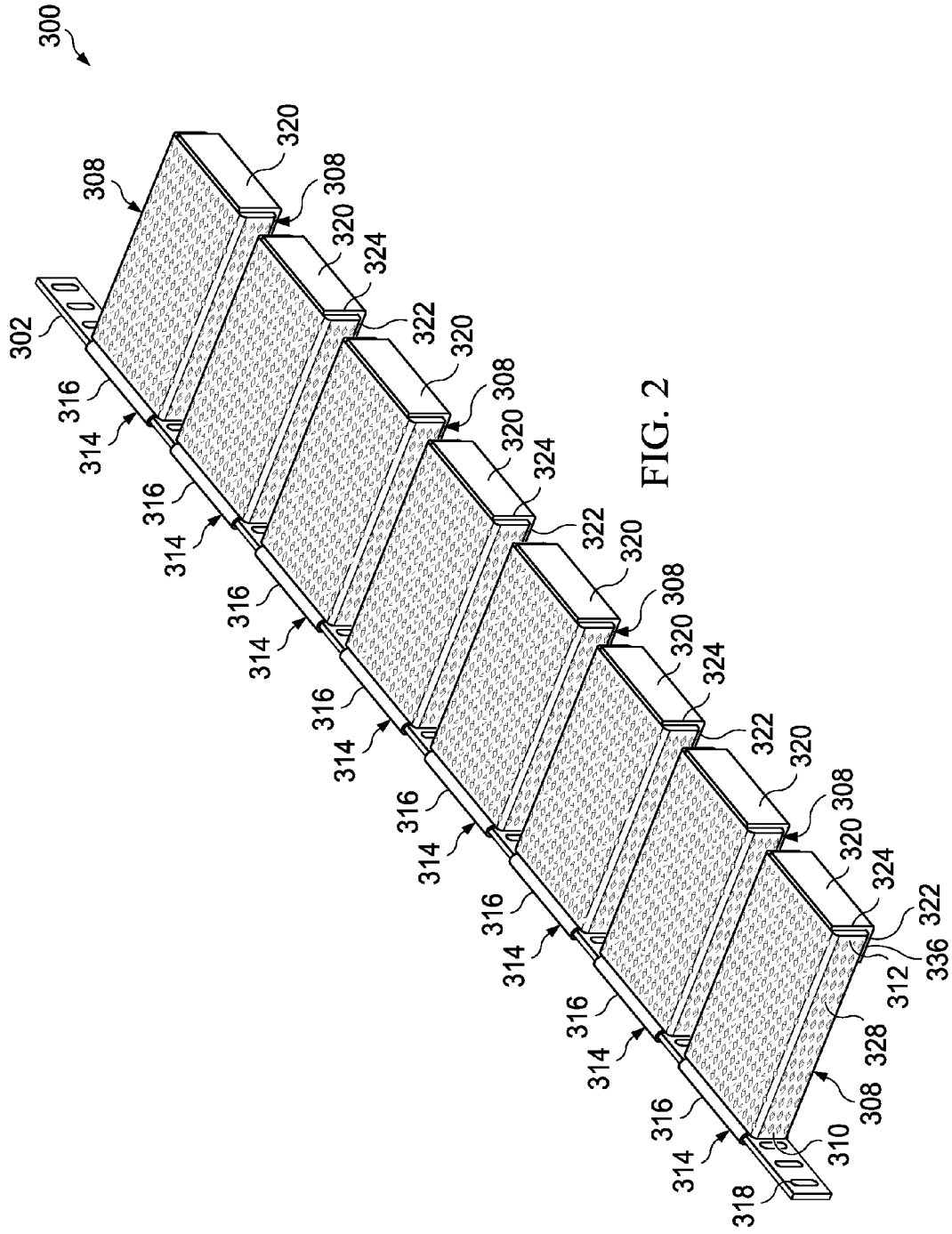

FIG. 1

100



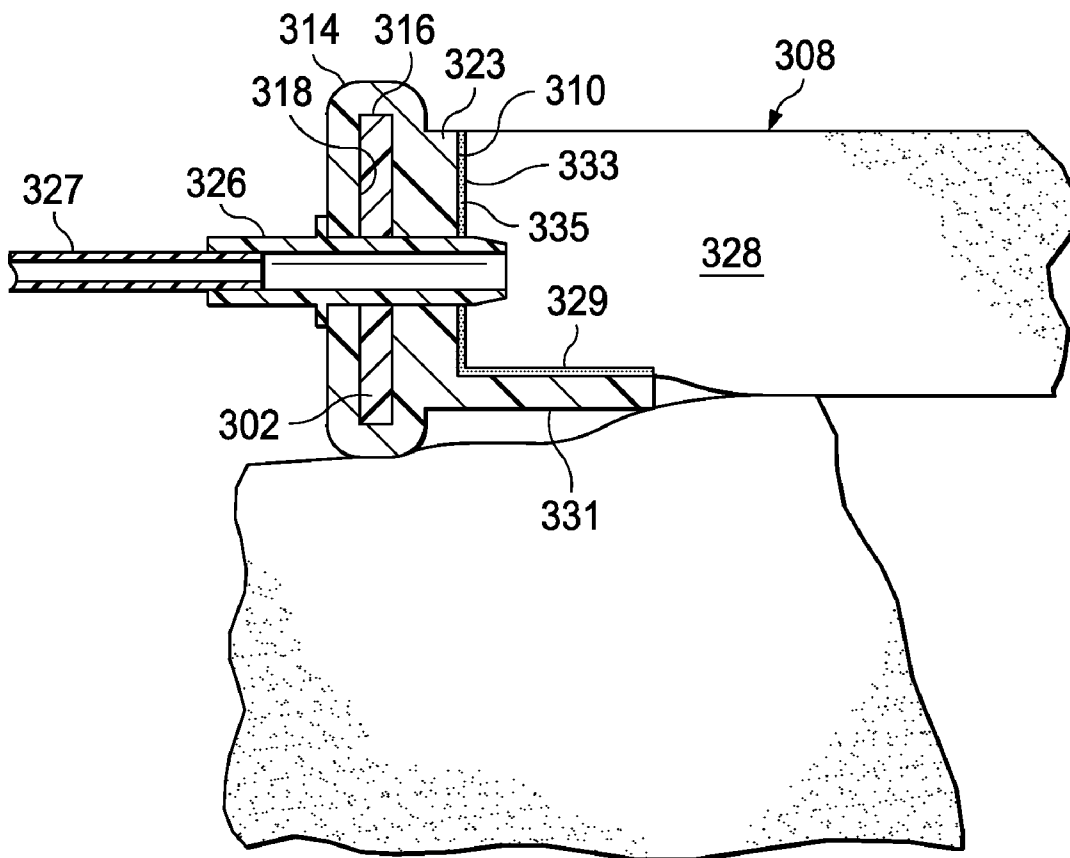

FIG. 3

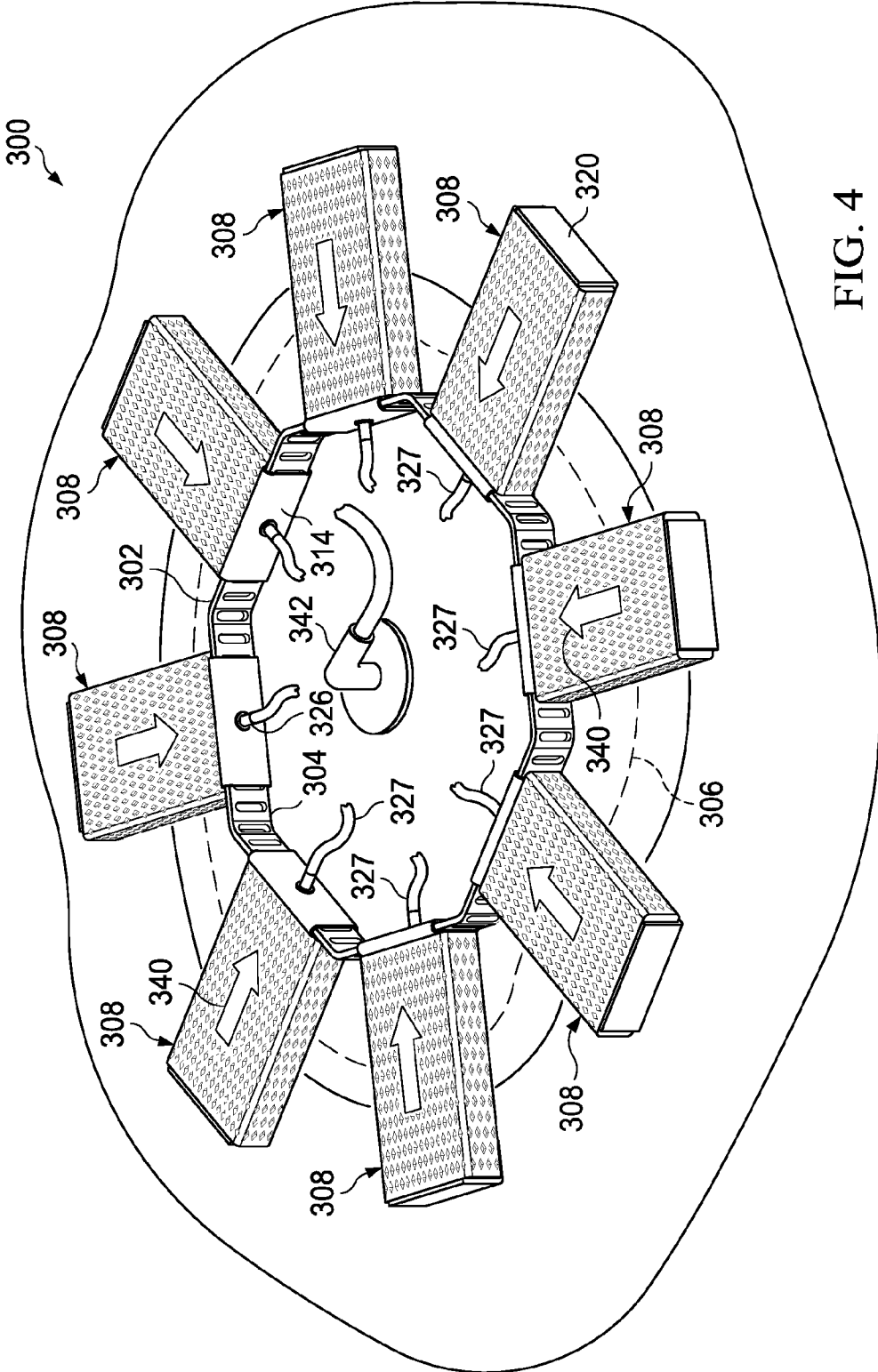
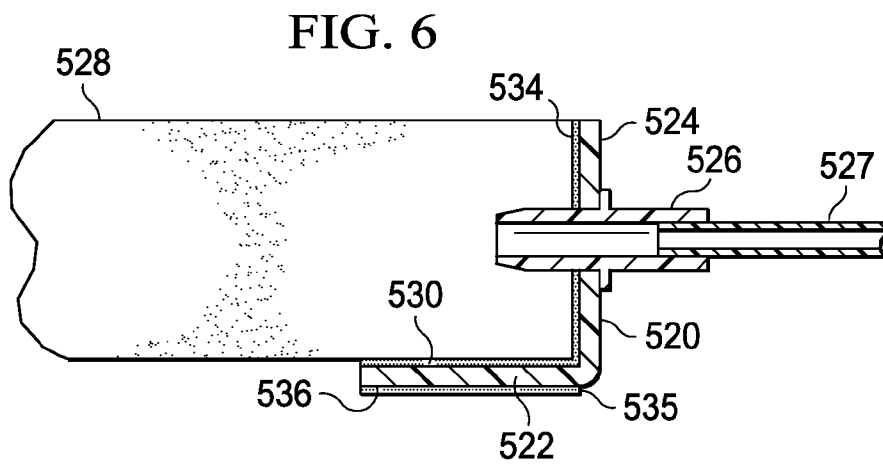
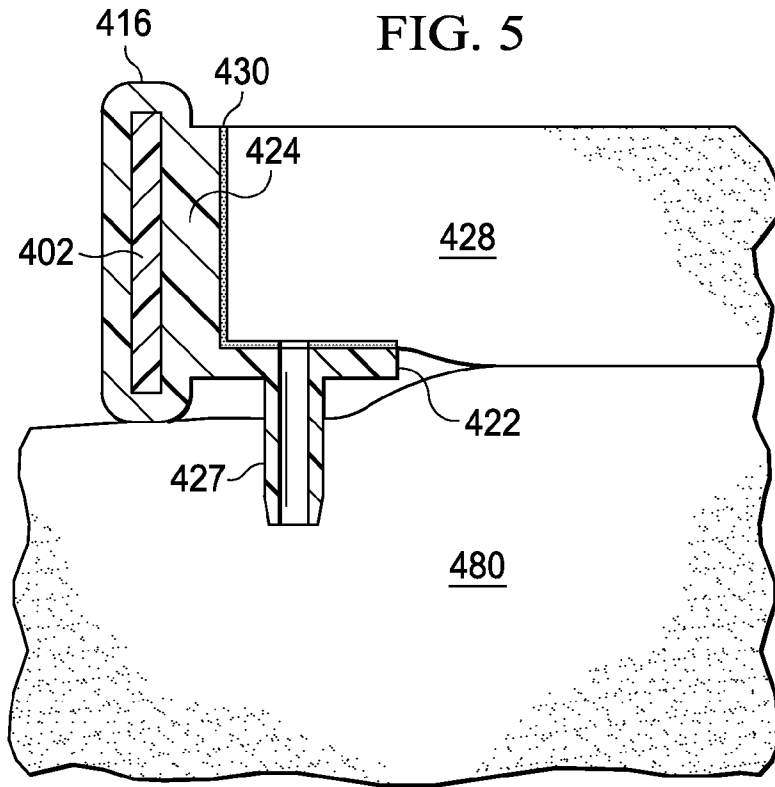

FIG. 4



MODULAR, REDUCED-PRESSURE, WOUND-CLOSURE SYSTEMS AND METHODS

RELATED APPLICATIONS

The present invention claims the benefit, under 35 USC §119(e), of the filing of U.S. Provisional Patent Application Ser. No. 61/109,410, entitled "Reduced-Pressure, Wound-Closure System and Method," filed Oct. 29, 2008; U.S. Provisional Patent Application Ser. No. 61/109,486, entitled "Reduced-Pressure, Abdominal Treatment System and Method," filed Oct. 29, 2008; U.S. Provisional Patent Application Ser. No. 61/109,390, entitled "Open-Cavity, Reduced-Pressure Wound Dressing and System," filed Oct. 29, 2008; and U.S. Provisional Patent Application Ser. No. 61/109,448, entitled "Reduced-Pressure, Deep-Tissue Closure System and Method," filed Oct. 29, 2008. All of these provisional applications are incorporated herein by reference for all purposes.

BACKGROUND

The present invention relates generally to medical treatment systems and, more particularly, to modular, reduced-pressure, wound-closure systems and methods.

Whether the etiology of a wound, or damaged area of tissue, is trauma, surgery, or another cause, proper care of the wound is important to the outcome. Unique challenges exist when the wound involves locations that require reentry, such as the peritoneal cavity and more generally the abdominal cavity. Many times when surgery or trauma involves the abdominal cavity, establishing a wound management system that facilitates reentry allows for better and easier care and helps to address such things as peritonitis, abdominal compartment syndrome (ACS), and infections that might inhibit final healing of the wound and the internal organs. In providing such care, it may be desirable to remove unwanted fluids from the cavity, help approximate the fascia and other tissues, or finally to help provide a closing force on the wound itself at the level of the epidermis. Unless otherwise indicated, as used herein, "or" does not require mutual exclusivity.

Currently, an abdominal opening on the epidermis may be closed using sutures, staples, clips, and other mechanical devices to allow the skin to be held and pulled. Such devices often cause puncture wounds or other wounds. Moreover, if severe edema occurs, tremendous pressure may be placed on the closure device and the pressure may cause harm. For example, if the pressure rises due to edema, the sutures may tear out.

With respect to an overall system for allowing reentry into the abdominal cavity, a number of techniques have been developed. One approach is to place towels into the cavity and then use clips, such as hemostats, to close the skin over the towels. While simple and fast, the results are regarded as suboptimal. Another approach is the so-called "Bogota bag." With this approach, a bag is sutured into place to cover the open abdomen in order to provide a barrier. Still another approach, sometimes called a "vac pack," is to pack towels in the wound and then place a drain into the abdomen and cover the abdomen with a drape. Finally, a reduced pressure approach has been used. Such an approach is shown in U.S. Pat. No. 7,381,859 to Hunt et al. and assigned to KCI Licensing, Inc. of San Antonio, Tex. U.S. Pat. No. 7,381,859 is incorporated herein by reference for all purposes.

SUMMARY

Problems with existing wound closure devices and reduced-pressure treatment systems are addressed by the sys-

tems, apparatus, and methods of the illustrative embodiments described herein. According to one illustrative embodiment, a modular, reduced-pressure wound-closure system includes a flexible strap operable to be formed into a closed loop and a plurality of modular closing members selectively coupled to the flexible strap. Each of the plurality of modular closing members includes an attachment member, a sealed contracting member, and a connection member. Each attachment member is for releasably attaching to a portion of the patient's epidermis proximate an edge of a surface wound and to a portion of a sealed contracting member. Each sealed contracting member is operable to contract under reduced pressure. Each connection member is coupled to a corresponding sealed contracting member and is operable to selectively couple to the flexible strap. Each modular closing member also includes a reduced-pressure interface fluidly coupled to the sealed contracting member for delivering a reduced pressure to the sealed contracting member. The modular, reduced-pressure wound-closure system also includes a reduced-pressure source fluidly coupled to each reduced-pressure interface of each of the plurality of modular closing members.

According to another illustrative embodiment, a method of manufacturing a modular, reduced-pressure, wound-closure system includes the steps of forming a flexible strap operable to be shaped into a closed loop and forming a plurality of modular closing members. The step of forming a plurality of modular closing members may include, for each of the plurality of modular closing members, the steps of forming an attachment member for releasably attaching to a portion of the patient's epidermis proximate an edge of the wound and forming a sealed contracting member. The sealed contracting member is operable to contract when placed under reduced pressure. The step of forming a plurality of modular closing members further includes coupling a second end of the sealed contracting member to the attachment member and forming a connection member. The connection member is operable to selectively couple to the flexible strap. The step of forming a plurality of modular closing members further includes coupling the connection member to a first end of the sealed contracting member. The illustrative method may further include the steps of fluidly coupling the closing, reduced pressure source to the plurality of modular closing members. The closing reduced-pressure source is operable to deliver a reduced pressure to each of the plurality of modular closing members.

According to another illustrative embodiment, a method of providing a closing force to a surface wound on a patient includes the steps of providing a flexible strap operable to be shaped into a closed loop and providing a plurality of modular closing members. The method of providing a closing force further includes the steps of shaping the flexible strap into a closed loop proximate the surface wound and providing a reduced pressure source. The method of providing a closing force further includes the steps of fluidly coupling the reduced-pressure source to the plurality of modular closing members and delivering reduced pressure to each of the plurality of modular closing members. When reduced pressure is delivered, the modular closing members generate a closing force. In this illustrative embodiment, each of the plurality of modular closing members includes an attachment member for releasably attaching to a portion of the patient's epidermis proximate an edge of the surface wound and a sealed contracting member, which has a first end and a second end. The second end of the sealed contracting member is coupled to the attachment member. The sealed contracting member is operable to contract when placed under reduced pressure. Each of the plurality of modular closing members further includes a

3

connection member coupled to the first end of the sealed contracting member and a reduced-pressure interface fluidly coupled the sealed contracting member for delivering reduced pressure to the sealed contracting member.

Other objects, features, and advantages of the illustrative embodiments will become apparent with reference to the drawings and detailed description that follow.

BRIEF DESCRIPTION OF THE DRAWINGS

FIG. 1 is a schematic cross-section, with a portion presented as a block diagram, of an illustrative embodiment of a modular, reduced-pressure, wound-closure and treatment system;

FIG. 2 is a schematic, perspective view of an illustrative embodiment of a portion of a modular, reduced-pressure, wound-closure system;

FIG. 3 is a schematic, cross-section of a portion of a modular closing member of the modular, reduced-pressure, wound-closure system of FIG. 2;

FIG. 4 is a schematic, perspective view of the illustrative modular, reduced-pressure, wound-closure system of FIGS. 2-3 shown deployed over a surface wound of a patient;

FIG. 5 is a schematic, cross-sectional view of an illustrative embodiment of a portion of a modular closing member; and

FIG. 6 is a schematic, cross-sectional view of an illustrative embodiment of a portion of a modular closing member.

DETAILED DESCRIPTION OF ILLUSTRATIVE EMBODIMENTS

In the following detailed description of the illustrative embodiments, reference is made to the accompanying drawings that form a part hereof. These embodiments are described in sufficient detail to enable those skilled in the art to practice the invention, and it is understood that other embodiments may be utilized and that logical structural, mechanical, electrical, and chemical changes may be made without departing from the spirit or scope of the invention. To avoid detail not necessary to enable those skilled in the art to practice the embodiments described herein, the description may omit certain information known to those skilled in the art. The following detailed description is, therefore, not to be taken in a limiting sense, and the scope of the illustrative embodiments are defined only by the appended claims.

Referring to FIG. 1, an illustrative embodiment of a reduced-pressure, wound-closure and treatment system 100 is presented. The reduced-pressure, wound-closure and treatment system 100 may include a reduced-pressure treatment subsystem 102 and a modular, reduced-pressure, wound-closure subsystem 104. The reduced-pressure treatment subsystem 102 may be used for treating a tissue site 106 with a reduced pressure. The tissue site 106 may be the bodily tissue of any human, animal, or other organism, including bone tissue, adipose tissue, muscle tissue, dermal tissue, vascular tissue, connective tissue, cartilage, tendons, ligaments, or any other tissue. The tissue site 106 may be within a body cavity, such as an abdominal cavity 110, and may include various tissue layers including a wound in epidermis 108. Treatment with the reduced-pressure treatment subsystem 102 may include removing fluids, such as ascites or exudates, delivering reduced pressure, or providing a protective barrier.

In the illustrative embodiment, the reduced-pressure, wound-closure and treatment system 100 is presented in the context of the abdominal cavity 110 and a surface wound 111, which has wound edges 112. Other subdermal tissue 114 may also have been opened, such as fat tissue, muscles, fascia, etc.

4

The abdominal cavity 110 is shown with abdominal contents 116, which form a surface or support.

The reduced-pressure treatment subsystem 102 of the reduced-pressure, wound-closure and treatment system 100 helps to deliver reduced pressure to the tissue site 106 and the abdominal cavity 110. The reduced-pressure treatment subsystem 102 includes a manifold 118 disposed within the abdominal cavity 110 to distribute reduced pressure within the abdominal cavity 110 and to receive fluids. The manifold 118 may include or be associated with a manifold member 120, or second manifold, in a non-adherent envelope 122. The non-adherent envelope 122 has apertures 124 on a first side and apertures 126 on a second, inward-facing (tissue-facing) side. The apertures 124 and 126 facilitate flow of fluids as suggested by arrows 128. The apertures 124 and 126 may take any shape, such as rectangular openings, circular openings, polygons, slits (elongated slots), etc. The non-adherent envelope 122 may be formed from a flexible film, such as a polyurethane film, a drape material, or any non-adherent material.

Reduced pressure may be applied by reduced-pressure treatment subsystem 102 to the abdominal cavity 110 and the tissue site 106 to help promote removal of exudates, ascites, or other liquids, bacteria, fibrin, dead tissue, toxins, residual blood, etc. Reduced pressure may also be used in certain situations to stimulate growth of additional tissue. In the case of a wound at the tissue site 106, the growth of granulation tissue and removal of exudates and bacteria may help to promote healing of the wound. In the situation of a non-wounded or non-defective tissue, reduced pressure may be used to promote the growth of tissue that may be harvested and transplanted to another tissue site. In other situations, fluid removal may be the main reason for applying reduced pressure.

As used herein, "reduced pressure" generally refers to a pressure less than the ambient pressure at the tissue site 106. In most cases, the reduced pressure will be less than atmospheric pressure at which the patient is located. Alternatively, the reduced pressure may be less than the hydrostatic pressure of the tissue site 106. Unless otherwise indicated, values of pressure stated herein are gauge pressures.

The manifold 118 and manifold member 120 are disposed in the abdominal cavity 110 and may be disposed at or near the tissue site 106. Typically, the non-adherent envelope 122, which contains the manifold member 120, is disposed against the tissue site 106 and, in particular, proximate the abdominal contents 116. The manifold 118 is disposed adjacent the non-adherent envelope 122. The manifold 118 and manifold member 120 may take many forms. The term "manifold" as used herein generally refers to a substance or structure that is provided to assist in applying reduced pressure to, delivering fluids to, or removing fluids from a tissue site, such as tissue site 106. The manifold 118 and manifold member 120 typically include a plurality of flow channels or pathways that distribute fluids provided to and removed from the area proximate the manifold 118 and manifold member 120. In one embodiment, the manifold 118 and manifold member 120 include a plurality of flow channels or pathways that are interconnected to improve distribution of fluids. The manifold 118 and manifold member 120 may be formed from a biocompatible material that is capable of being placed in contact with tissue and that distributes reduced pressure. Examples of manifolds may include, without limitation, devices that have structural elements arranged to form flow channels, cellular foam, such as open-cell foam, porous tissue collections, and liquids, gels and foams that include or cure to include flow channels.

The manifold **118** and manifold member **120** may be porous and may be made from foam, gauze, felted mat, or any other material suited to a particular biological application. In one embodiment, the manifold **118** and manifold member **120** are made from a porous foam that includes a plurality of interconnected cells or pores that act as flow channels. The porous foam may be a polyurethane, open-cell, reticulated foam, such as a GranuFoam® material manufactured by Kinetic Concepts, Incorporated of San Antonio, Tex. Other embodiments may include “closed cells.” In some situations, the manifold **118**, the manifold member **120**, and the non-adherent envelope **122** may be used to distribute fluids, such as medications, antibacterials, growth factors, and other solutions to the tissue site **106**. Other layers may be included as part of the manifold **118** or manifold member **120**, such as absorptive material, wicking material, hydrophobic material, and hydrophilic material.

A sealing member **132** may be placed over the surface wound **111** in epidermis **108** and, in particular, made to overlap the wound edges **112** to provide a pneumatic seal. Thus, the sealing member **132** provides a seal over the manifold **118** and the non-adherent envelope **122**. The sealing member **132** may be a cover that is used to secure the manifold **118** and non-adherent envelope **122** at the tissue site **106**. While the sealing member **132** may be impermeable or semi-permeable, the sealing member **132** is capable of maintaining a reduced pressure at the tissue site **106** after installation of the sealing member **132** over the manifold **118**. The sealing member **132** may be a flexible over-drape or film formed from a silicone based compound, acrylic, hydrogel or hydrogel-forming material, or any other biocompatible material that includes the impermeability or permeability characteristics desired for the intended tissue site.

The sealing member **132** may further include an attachment device **136** to secure the sealing member **132** to a patient’s epidermis **108**. The attachment device **136** may take many forms; for example, a sealing tape might be used or an adhesive **134** may be positioned along a perimeter of the sealing member **132** or any portion of the sealing member **132** to provide a pneumatic seal. The adhesive **134** might also be pre-applied and covered with a releasable member (not shown) that is removed at the time of application.

A first reduced-pressure interface **138**, such as a port **140** or connector, may be used to deliver reduced pressure from a first reduced-pressure delivery conduit **142** to the manifold **118**. The first reduced-pressure interface **138** may also deliver any exudate, ascites, or other fluids from the manifold **118**. The reduced pressure in the manifold **118** pulls the fluid in the direction shown by arrows **144** and to the first reduced-pressure delivery conduit **142**. The first reduced-pressure interface **138** permits the passage of fluid from the manifold **118** to the first reduced-pressure delivery conduit **142**. For example, fluids collected from the tissue site **106** using the manifold member **120** and the manifold **118** may enter the first reduced-pressure delivery conduit **142** via the first reduced-pressure interface **138**. In another embodiment, the reduced-pressure treatment subsystem **102** may exclude the first reduced-pressure interface **138**, and the first reduced-pressure delivery conduit **142** may be inserted directly into the sealing member **132** and the manifold **118**. The first reduced-pressure delivery conduit **142** may be a medical conduit, multi-lumen member, tubing, or any other means for delivering a reduced pressure.

A reduced-pressure subsystem **148** may be used to supply the reduced pressure that is delivered to the first reduced-pressure delivery conduit **142**. The reduced-pressure subsystem **148** may include a first reduced-pressure unit, or

source, **150** that delivers reduced pressure to a conduit **152**, which delivers the reduced pressure to a three-way valve **154**. One portion of the reduced pressure may leave the three-way valve **154** through a second reduced-pressure delivery conduit **156**. Another portion of the reduced pressure may leave the three-way valve **154** through a reduced-pressure conduit **158**. Located on the reduced-pressure conduit **158** may be any number of devices, such as a reduced-pressure feedback unit **160**, which may, for example, give feedback to the three-way valve **154** concerning the regulation of the reduced pressure within the reduced-pressure conduit **158**. The reduced-pressure conduit **158** delivers the reduced pressure to a canister **162**, which is operable to hold any fluids delivered to the canister **162** from the tissue site **106**. Reduced pressure leaving the canister **162** is delivered to the first reduced-pressure delivery conduit **142**. The first reduced-pressure delivery conduit **142** may be referred to as delivering a treatment-reduced-pressure because the reduced pressure therein has been placed, by the reduced-pressure subsystem **148**, at the desired pressure and conditions for use in reduced-pressure treatment at the tissue site **106**. The reduced pressure delivered to the first reduced-pressure delivery conduit **142** is typically selected to be in the range of -50 mm Hg to -500 mm Hg and more typically in the range of -100 mm Hg to -300 mm Hg at the tissue site **106**.

A number of different devices, e.g., device **166**, may be added to a medial portion **164** of the first reduced-pressure delivery conduit **142**. The device **166** might be a pressure feedback device, a volume detection system, a blood detection system, an infection detection system, a flow monitoring system, a temperature monitoring system, etc. Some of these devices may be formed integrally to other parts; for example, the canister **162** may include one or more filters, e.g., a hydrophobic filter that prevents liquid from exiting.

There are many ways of developing or supplying the reduced pressure to be used with the reduced-pressure, wound-closure and treatment system **100**. In the illustrative embodiment shown, the first reduced-pressure unit **150** is used for both applications, i.e., for wound closing and for reduced-pressure treatment. In an alternative embodiment, it may be desirable to use the first reduced-pressure unit **150** as the source for the second reduced-pressure delivery conduit **156** and have a second reduced-pressure unit **151** (shown in broken lines) to deliver reduced pressure to the reduced-pressure conduit **158**.

As an aspect of the reduced-pressure, wound-closure and treatment system **100**, it is also desirable to help provide a closing force to the surface wound **111** and in particular to apply a closing force between the wound edges **112**. As shown in FIG. **1**, the modular, reduced-pressure, wound-closure subsystem **104** may be used for this purpose. The modular, reduced-pressure, wound-closure subsystem **104** develops a closing force represented by arrows **170**. The closing force is communicated to the epidermis **108** and urges the wound edges **112** towards each other. The modular, reduced-pressure, wound-closure subsystem **104** may be a stand-alone system for closing any surface wound or used as part of a larger system, e.g., the reduced-pressure, wound-closure and treatment system **100**.

The modular, reduced-pressure, wound-closure subsystem **104** includes a spacing member, such as a flexible strap **171**, which is shaped into a closed loop inboard of the wound edges **112** (see, e.g., FIG. **4**), and a plurality of modular closing members **169** associated with the flexible strap **171**. Alternatively, the spacing member may be one or more tie wires that hold the modular closing members **169** in a spaced relationship or a flexible adhesive film placed on top of the modular

closing members **169** that hold the modular closing members **169** in a spaced relationship. Each modular closing member **169** has a sealed contracting member **195**, a connection member **181**, and an attachment member **211**. Before forming the closed loop, the plurality of modular closing members **169**, e.g., a first modular closing member **173** and a second modular closing member **175**, are attached to the flexible strap **171**. The plurality of modular closing members **169** is analogous to the modular closing members **308** in FIG. 2. The number of modular closing members **169** included on the flexible strap **171** is determined by the size of the loop needed to surround the surface wound **111**.

Each modular closing member of the plurality of modular closing members **169** has a first end **177**, which is typically placed inboard of the surface wound **111**, and a second end **179**, which is typically placed outboard of the surface wound **111**. Each connection member **181** is coupled to the first end **177** of the corresponding modular closing member **169**. In the illustrative embodiment of FIG. 1, each connection member **181** includes an attachment opening or loop **185** through which the flexible strap **171** may be placed. The attachment loops **185** allow each modular closing member **169** to be positioned in a desired location along the flexible strap **171**.

A reduced-pressure interface **186** is coupled to each modular connection member **181**. A plurality of reduced-pressure conduits **187** is fluidly coupled to the reduced-pressure interface **186** to provide reduced pressure thereto. The reduced pressure supplied through the second reduced-pressure delivery conduit **156** is fluidly coupled to a distributor **223** that is fluidly coupled to the plurality of reduced-pressure conduits **187** that are fluidly coupled to the plurality of reduced-pressure interfaces **186** to deliver reduced pressure to each modular closing member **169**. For each modular closing member **169**, the reduced-pressure interface **186** delivers reduced pressure to the sealed contracting member **195**. Each reduced-pressure interface **186** may also function as a pin to hold the corresponding connection member **181** in place relative to the flexible strap **171**.

Each modular closing member **169** of the modular, wound-closure subsystem **104** includes the sealed contracting member **195** that is used to develop a closing force. The sealed contracting member **195** may be formed from a contracting manifold material, which may be the same type of material as the manifold **118**. Alternatively, it may be desirable to use a contracting manifold material that has fewer apertures or holes than the material used for the manifold **118**. In addition, it may be desirable to have a material that will contract less in the vertical (for the orientation shown in FIG. 1) and more in the horizontal, or lateral, plane (for the orientation shown in FIG. 1). In an alternative embodiment, the sealed contracting member **195** may be formed with a pneumatic device to develop a closing force. For example, a chamber that collapses under reduced pressure may be used. The sealed contracting member **195** has a first side **190** and a second, inward-facing side **192**. The sealed contracting member **195** is sealed to form a pneumatic seal about an interior space of the sealed contracting member **195**.

Each connection member **181** of the plurality of modular closing members **169** includes a base **203** and a wall **209**. The base **203** and wall **209** are formed integrally or are otherwise coupled by any technique, such as welding, bonding, adhesives, cements, etc. Each attachment member **211** has a base **213** and a wall **215**. The base **213** and wall **215** of the attachment member **211** are formed integrally or otherwise coupled by any technique, such as those previously mentioned. An adhesive **197** or other attachment device may be used to hold the sealed contracting member **195** to the base **203** of the

corresponding connection member **181**. An adhesive **205** or other attachment device may be also be used to attach a peripheral edge **207** of the sealed contracting member **195** to a wall **209** of the corresponding connection member **181**. An adhesive **217** or other attachment device may be used to hold the sealed contracting member **195** to the base **213** of the corresponding attachment member **211**. An adhesive **219** or other attachment device may also be used to hold the sealed contracting member **195** to the wall **215** of the corresponding attachment member **211**. An adhesive **227** or other attachment device may be used to releasably attach the base **213** to the epidermis **108** (or sealing member if already deployed on epidermis).

In operation, the reduced-pressure, wound-closure and treatment system **100** may be used in a body cavity, e.g., abdominal cavity **110**, by first applying a manifold material on the abdominal contents **116**. For example, the manifold member **120** with the non-adherent envelope **122** may be placed on the abdominal contents **116** and the manifold **118** disposed proximate the non-adherent envelope **122**. The wound edges **112** of the surface wound **111** may be brought together to the extent possible, and then the sealing member **132** placed onto the epidermis **108** to provide a pneumatic seal over the surface wound **111**.

The healthcare provider may measure or estimate the circumference of the surface wound **111** and then using a look-up table, determine the number of modular closing members **169**, e.g., first modular closing member **173**, which need to be added to the flexible strap **171**. The flexible strap **171** is also cut or otherwise sized to a proper length. The plurality of modular closing members **169**, e.g., modular closing members **173** and **175**, desired are added to the flexible strap **171**. The flexible strap **171** is formed into a closed loop that has a circumference less than the circumference of the surface wound **111**. The closed loop is substantially centered on the surface wound **111** and each of the attachment members **211** are secured to the patient's epidermis **108** (or to the sealing member **132**). In this regard, as used herein, references to attaching to the patient's epidermis **108** should be deemed to include attachment to a sealing member **132** on the epidermis **108**.

The first reduced-pressure interface **138**, which may be the reduced-pressure port **140**, may be applied such that an extended portion **202** reaches into the manifold **118**. The first reduced-pressure delivery conduit **142** may be coupled to the first reduced-pressure interface **138** to provide a fluid coupling with the first reduced-pressure unit **150** (or an optional second reduced-pressure unit **151**). The second reduced-pressure delivery conduit **156** may be fluidly coupled to the distributor **223**. The plurality of reduced-pressure conduits **187** are fluidly coupled to the distributor **223** and to the plurality of reduced-pressure interfaces **186**.

The reduced-pressure, wound-closure and treatment system **100** is activated such that the first reduced-pressure unit **150** delivers reduced pressure through the three-way valve **154**, which prepares the treatment-reduced-pressure that is delivered to the first reduced-pressure delivery conduit **142** and a closing-reduced-pressure that is delivered to the second reduced-pressure delivery conduit **156**. The treatment-reduced-pressure delivered through the first reduced-pressure delivery conduit **142** is realized at the manifold **118**, which pulls fluids as suggested by arrows **144** and **128** and distributes reduced pressure within the abdominal cavity **110**. The closing-reduced-pressure is delivered through the second reduced-pressure delivery conduit **156** to the distributor **223** and through the plurality of reduced-pressure conduits **187** to the plurality of modular closing members **169**. The closing-

reduced-pressure is received by the plurality of modular closing members 169 and is delivered to the interior of each of the sealed contracting member 195, and causes each of the sealed contracting members 195 to contract and thereby to develop a closing force between the flexible strap 171 and the attachment members 211. The net result is to provide a closing force urging the wound edges 112 inward.

Referring now to FIGS. 2-4, an illustrative embodiment of a modular, reduced-pressure, wound-closure system 300 is presented. The modular, reduced-pressure, wound-closure system 300 may be used as the modular, wound-closure subsystem 104 of FIG. 1. The modular, reduced-pressure, wound-closure system 300 may include a flexible strap 302 with a plurality of modular closing members 308. Each modular closing member 308 includes an attachment member 320 and a connection member 314. Use of modular members 308 allows numerous sizes and shapes of surface wounds to be accommodated without requiring a large stock of different sizes and shapes of wound dressings or devices.

The flexible strap 302 is shown in a linear position in FIG. 2 and shaped into a closed loop 304 in FIG. 4. The flexible strap 302 is shaped into the closed loop 304 around a surface wound 306, such as an opening on a patient's epidermis. The plurality of modular closing members 308 is selectively coupled to the flexible strap 302. The number of modular closing members 308 included on the flexible strap 302 is determined by the size of the closed loop 304 needed to surround the surface wound 306. Thus, to surround the surface wound 306 in FIG. 4, eight modular closing members 308 have been included on the flexible strap 302. Referring again to FIG. 2, each modular closing member 308 has a first end 310 and a second end 312.

Each connection member 314 is coupled to the first end 310 of each modular closing member 308. In the illustrative embodiment of FIG. 2, each connection member 314 includes an attachment loop or opening 316 through which the flexible strap 302 may be placed. The attachment loops 316 allow each modular closing member 308 to be positioned in a desired location along the flexible strap 302. A portion of each attachment loop 316 may interface with a strap opening 318 to help hold the connection member 314 in position on the flexible strap 302. Alternatively or in addition, a reduced-pressure interface 326 may function as a peg to hold the connection member 314 in place relative to the flexible strap 302.

Referring now primarily to FIG. 3, a connection member 314 is presented. The reduced-pressure interface 326 is shown coupled to the connection member 314. A reduced-pressure conduit 327 is fluidly coupled to the reduced-pressure interface 326 to provide reduced pressure to the reduced-pressure interface 326. The reduced-pressure interface 326 delivers the reduced pressure to a sealed contracting member 328 and, as previously mentioned, the reduced-pressure interface 326 may function as a pin to hold the connection member 314 in place relative to the flexible strap 302.

The sealed contracting member 328 is made of the same or similar materials as the previously mentioned sealed contracting member 195 of FIG. 1. The sealed contracting member 328 is sealed to form a pneumatic seal about an interior space of the sealed contracting member 328. An adhesive 329 or other attachment device (e.g., cement, weld, hooks, etc.) may be used to hold the sealed contracting member 328 to a base 331. An adhesive 335 or other attachment device (e.g., cement, weld, hooks, etc.) may be also be used to attach a peripheral edge 333 of the sealed contracting member 328 to a wall 323 of the connection member 314.

Referring again primarily to FIG. 2, an attachment member 320 may be coupled to each of the second ends 312 of the sealed contracting member 328. Each of the attachment members 320 may be formed with a base 322 and a wall 324. An adhesive (not explicitly shown) or other attachment device (e.g., cement, weld, hooks, etc.) may be used to hold the sealed contracting member 328 to the base 322. An adhesive (not explicitly shown) or other attachment device (e.g., cement, weld, hooks, etc.) may also be used to hold the sealed contracting member 328 to the wall 324.

Referring now primarily to FIG. 5, an alternative reduced-pressure interface 427 is presented as part of a connection member 416. Reduced pressure may be provided to a sealed contracting member 428 through the connection member 416. The connection member 416 selectively attaches to a flexible strap 402. An adhesive 430 may be used to hold the sealed contracting member 428 to the connection member 416. The connection member 416 may have a wall 424 and a base 422 that are formed integrally or otherwise coupled by any technique, e.g., welding (RF weld or ultrasonic), bonding, adhesives, cements, etc. The reduced-pressure interface 427 may be formed on the base 422 and configured to enter a manifold 480, or manifold pad. The reduced-pressure interface 427 is sized and configured to engage the manifold 480, which is in fluid communication with, or is fluidly coupled to, a reduced pressure source. The reduced pressure is delivered to the manifold 480 which communicates the reduced pressure through the reduced-pressure interface 427 to the sealed contracting member 428.

Referring again primarily to FIGS. 2-4, one illustrative method of operating the modular, reduced-pressure, wound-closure system 300 will be presented. In operation, a healthcare provider assesses the size of the surface wound 306 and determines the number of modular closing members 308 that are appropriate for the size of the surface wound 306. A look-up chart or table based on a measurement of the circumference of the surface wound 306 may be used to suggest the appropriate number of the modular closing members 308. The appropriate number of the modular closing members 308 is then selectively coupled to the flexible strap 302. The flexible strap 302 is then shaped into the closed loop 304, which is preferably sized to be inboard of the peripheral edges of surface wound 306. The flexible strap 302 is secured to form the closed loop 304 using any number of means, such as a ratchet, snap, fastener, ratchet ties, flexible peg and slot members, etc. Then, each of the plurality of attachment members 320 is attached to the patient's epidermis proximate the edge of the surface wound 306. As before, the statement that the attachment members 320 are attached to the epidermis may include that the attachment members 320 are attached to a sealing member being used for reduced-pressure treatment.

In applying each attachment member 320, the base 322 may have an adhesive (see adhesive 227 in FIG. 1) or other attachment device applied on a second, inward-facing surface 336. The adhesive may have a releasable backing on the adhesive that is removed prior to use. Thus, the healthcare provider would pull off the backing, exposing the adhesive, and then press the adhesive on the epidermis (or sealing member). Then, each reduced-pressure interface 326 associated with each of the plurality of connection members 314 is coupled to a reduced-pressure source, such as by a reduced-pressure conduit 327 or a distributor (not shown). (Alternatively, the reduced-pressure interface 427 of FIG. 5 may have already been introduced into the manifold 480 if used.) After activating the reduced-pressure source, reduced pressure is supplied to the reduced-pressure conduit 327 which delivers the reduced pressure through the reduced-pressure interface

326 to the sealed contracting member 328. The reduced pressure causes the sealed contracting member 328 to contract. As the sealed contracting member 328 contracts, the sealed contracting member 328 develops a closing force represented by arrows 340 in FIG. 4. The closed loop 304 remains substantially in relative position, and thus each attachment member 320 pulls the epidermis inward.

The closed loop 304 provides an open area in the middle of the closed loop 304 that readily accommodates a reduced-pressure interface 342 if reduced-pressure treatment is also desired. The reduced-pressure interface 342 may be used to supply reduced pressure to a reduced-pressure treatment system (see, e.g., reduced-pressure treatment subsystem 102 in FIG. 1).

Referring now primarily to FIG. 6, another alternative, illustrative embodiment of a reduced-pressure interface 526 is presented. The reduced-pressure interface 526 is formed as part of an attachment member 520. The attachment member 520 includes a base 522 and a wall 524 formed integrally or otherwise coupled. An adhesive 530 or other attachment device (e.g., bond, cements, weld, etc.) may hold, or secure, a portion of a contracting member 528 to the base 522. An adhesive 534 or other attachment device (e.g., bond, cements, weld, etc.) may hold a portion of the contracting member 528 to the wall 524. An adhesive 535 or other attachment device (e.g., bond, cements, suture, etc.) on an inward-facing side 536 of the base 522 may be used to attach the base 522 to a patient's epidermis (or sealing member). In this illustrative embodiment, the reduced-pressure interface 526, which is fluidly coupled to a reduced-pressure conduit 527, extends through the wall 524 and delivers reduced pressure to the sealed contracting member 528.

Referring again to FIG. 4, another embodiment will be presented. In this alternative embodiment, a set number of the modular closing members 308 are slideably attached to the strap 302 and may be provided in a closure kit as such. When applying the wound-closure system 300, the healthcare provider appropriately spaces the set number of modular closing members 308—usually equidistant from one another—on a portion of the strap 302 to be used and forms the closed loop 304. Any extra portion of the strap 302, i.e., a portion not needed to form the closed loop 304, may be cut and removed.

According to another illustrative embodiment, a modular wound closure system for closing a wound on a patient's epidermis using reduced pressure includes a plurality of closing devices that contract when under the influence of reduced pressure. Each of the closing devices have a distal end and a proximal end. The system further includes a flexible member for maintaining the plurality of closing devices in a spaced relationship with the proximal ends inboard of an edge of the wound. The system also includes a plurality of attachment apparatuses for releasably coupling the distal ends of the plurality of closing devices to the patient's epidermis outboard of the edge of the wound. The system further includes a plurality of reduced-pressure connectors for providing reduced pressure to the plurality of closing devices. The plurality of closing devices may be formed as a plurality of sealed contracting members. The plurality of closing devices may be detachably mated to the flexible member. The plurality of closing devices have a first volume (V1) at an ambient pressure and have a second volume (V2) at a reduced pressure and wherein $V1 > V2$. The plurality of closing devices may be slideably mated to the flexible member.

Although the present invention and its advantages have been disclosed in the context of certain illustrative, non-limiting embodiments, it should be understood that various changes, substitutions, permutations, and alterations can be

made without departing from the scope of the invention as defined by the appended claims.

We claim:

1. A modular, reduced-pressure wound-closure system for providing a closing force on a surface wound, the system comprising:

a flexible strap operable to be formed into a closed loop; and

a plurality of modular closing members selectively coupled to the flexible strap, each of the plurality of modular closing members comprising:

an attachment member for releasably attaching to a portion of a patient's epidermis proximate an edge of the surface wound, the attachment member having a base and a wall,

a sealed contracting member, which has a pneumatically sealed interior, having a first end and a second end, the second end coupled to the attachment member, wherein the sealed contracting member is operable to contract under reduced pressure,

a connection member coupled to the first end of the sealed contracting member, the connection member operable to selectively couple to the flexible strap, and a reduced-pressure interface fluidly coupled to the pneumatically sealed interior of the sealed contracting member for delivering a reduced pressure to the sealed contracting member.

2. The modular, reduced-pressure wound-closure system of claim 1 further comprising a reduced-pressure source fluidly coupled to each reduced-pressure interface of each of the plurality of modular closing members, the reduced-pressure source operable to deliver reduced pressure to each reduced-pressure interface of the plurality of modular closing members.

3. The modular, reduced-pressure wound-closure system of claim 1 further comprising a reduced-pressure source fluidly coupled to each reduced-pressure interface of each of the plurality of modular closing members, the reduced-pressure source operable to deliver reduced pressure to each reduced-pressure interface of the plurality of modular closing members and wherein for each modular closing member, the reduced-pressure interface is coupled to the connection member.

4. The modular, reduced-pressure wound-closure system of claim 1 further comprising a reduced-pressure source fluidly coupled to each reduced-pressure interface of each of the plurality of modular closing members, the reduced-pressure source operable to deliver reduced pressure to each reduced-pressure interface of the plurality of modular closing members and wherein for each modular closing member, the reduced-pressure interface is coupled to the attachment member.

5. The modular, reduced-pressure wound-closure system of claim 1 wherein the flexible strap is formed with a plurality of strap openings and wherein each reduced-pressure interface of each of the plurality of modular closing members is sized and configured to extend through a strap opening.

6. The modular, reduced-pressure wound-closure system of claim 1 wherein each sealed contracting member comprises a contracting manifold material.

7. The modular, reduced-pressure wound-closure system of claim 1 wherein:

for each modular closing member, the reduced-pressure interface is coupled to the connection member;

the flexible strap is formed with a plurality of strap openings and wherein each reduced-pressure interface of

13

each of the plurality of modular closing members is sized and configured to extend through a strap opening; and
 and
 each sealed contracting member comprises a contracting manifold material.

8. A method of manufacturing a modular, reduced-pressure, wound-closure system for generating a closing force on a surface wound, the method comprising the steps of:

forming a flexible strap operable to be shaped into a closed loop; and

forming a plurality of modular closing members, wherein the step of forming a plurality of modular closing members comprises, for each of the plurality of modular closing members, the steps of:

forming an attachment member, the attachment member for releasably attaching to a portion of a patient's epidermis proximate an edge of the surface wound,

forming a pneumatically sealed contracting member having a first end and a second end, wherein the sealed contracting member is operable to contract under reduced pressure,

coupling the second end of the sealed contracting member to the attachment member,

forming a connection member, the connection member operable to selectively couple to the flexible strap, and coupling the connection member to the first end of the sealed contracting member.

9. The method of manufacturing of claim 8 further comprising:

fluidly coupling a reduced-pressure interface to the sealed contracting member of each modular closing member for delivering a reduced pressure to the sealed contracting member.

10. The method of manufacturing of claim 8 further comprising the steps of:

providing a closing, reduced-pressure source; and

fluidly coupling the closing, reduced pressure source to each reduced-pressure interface of the plurality of modular closing members, the closing reduced-pressure source operable to deliver reduced pressure to each reduced-pressure interface of the plurality of modular closing members.

11. The method of manufacturing of claim 9 wherein the step of fluidly coupling a reduced-pressure interface to the sealed contracting member comprises coupling a reduced-pressure interface to the connection member.

12. The method of manufacturing of claim 9 wherein the step of fluidly coupling a reduced-pressure interface to the

14

sealed contracting member comprises coupling a reduced-pressure interface to the attachment member.

13. The method of manufacturing of claim 8 wherein the step of forming a flexible strap comprises the step of forming a flexible strap with a plurality of strap openings.

14. The method of manufacturing of claim 8 wherein the step of forming a sealed contracting member comprises the step of forming a sealed contracting member that includes a contracting manifold material.

15. The method of manufacturing of claim 9 wherein:

the step of fluidly coupling a reduced-pressure interface to the sealed contracting member comprising coupling a reduced-pressure interface to the connection member; the step of forming a flexible strap comprises the step of forming a flexible strap with a plurality of strap openings; and

the step of forming a sealed contracting member comprises the step of forming a sealed contracting member that includes a contracting manifold material.

16. A modular wound closure system for closing a wound on a patient's epidermis using reduced pressure, the system comprising:

a plurality of closing devices that contract when under the influence of reduced pressure, each closing device having a distal end and a proximal end, the plurality of closing devices comprising a plurality of sealed contracting members having a pneumatically sealed interior;

a flexible member for maintaining the plurality of closing devices in a spaced relationship with the proximal ends inboard of an edge of the wound;

a plurality of attachment apparatuses for releasable coupling the distal ends of the plurality of closing devices to the patient's epidermis outboard of the edge of the wound; and

a plurality of reduced-pressure connectors for providing reduced pressure to the pneumatically sealed interiors of the plurality of closing devices.

17. The wound closure system of claim 16 wherein the plurality of closing devices are detachably mated to the flexible member.

18. The wound closure system of claim 16 wherein the plurality of closing devices have a first volume (V_1) at an ambient pressure and have a second volume (V_2) at a reduced pressure and wherein $V_1 > V_2$.

19. The wound closure system of claim 16 wherein the plurality of closing devices are slideably mated to the flexible member.

* * * * *