



- (51) **International Patent Classification:**  
*C09J 9/02* (2006.01) *F03D 1/06* (2006.01)
- (21) **International Application Number:**  
PCT/US2019/024563
- (22) **International Filing Date:**  
28 March 2019 (28.03.2019)
- (25) **Filing Language:** English
- (26) **Publication Language:** English
- (30) **Priority Data:**  
62/649,054 28 March 2018 (28.03.2018) US
- (71) **Applicant:** ZOLTEK CORPORATION [US/US]; 3101 McKelvey Road, Bridgeton, MO 63044 (US).
- (72) **Inventors:** BALDINI, Steven, Eric; c/o Zoltek Corporation, 3101 McKelvey Road, Bridgeton, MO 63044 (US). CORBIN, David, Michael; c/o Zoltek Corporation, 3101 McKelvey Road, Bridgeton, MO 63044 (US).
- (74) **Agent:** COHEN, Joshua, L. et al.; RatnerPrestia, 2200 Renaissance Boulevard, Suite 350, King of Prussia, PA 19406 (US).
- (81) **Designated States** (unless otherwise indicated, for every kind of national protection available): AE, AG, AL, AM, AO, AT, AU, AZ, BA, BB, BG, BH, BN, BR, BW, BY, BZ, CA, CH, CL, CN, CO, CR, CU, CZ, DE, DJ, DK, DM, DO, DZ, EC, EE, EG, ES, FI, GB, GD, GE, GH, GM, GT, HN, HR, HU, ID, IL, IN, IR, IS, JO, JP, KE, KG, KH, KN, KP, KR, KW, KZ, LA, LC, LK, LR, LS, LU, LY, MA, MD, ME,

MG, MK, MN, MW, MX, MY, MZ, NA, NG, NI, NO, NZ, OM, PA, PE, PG, PH, PL, PT, QA, RO, RS, RU, RW, SA, SC, SD, SE, SG, SK, SL, SM, ST, SV, SY, TH, TJ, TM, TN, TR, TT, TZ, UA, UG, US, UZ, VC, VN, ZA, ZM, ZW.

- (84) **Designated States** (unless otherwise indicated, for every kind of regional protection available): ARIPO (BW, GH, GM, KE, LR, LS, MW, MZ, NA, RW, SD, SL, ST, SZ, TZ, UG, ZM, ZW), Eurasian (AM, AZ, BY, KG, KZ, RU, TJ, TM), European (AL, AT, BE, BG, CH, CY, CZ, DE, DK, EE, ES, FI, FR, GB, GR, HR, HU, IE, IS, IT, LT, LU, LV, MC, MK, MT, NL, NO, PL, PT, RO, RS, SE, SI, SK, SM, TR), OAPI (BF, BJ, CF, CG, CI, CM, GA, GN, GQ, GW, KM, ML, MR, NE, SN, TD, TG).

**Declarations under Rule 4.17:**

- as to applicant's entitlement to apply for and be granted a patent (Rule 4.17(ii))
- as to the applicant's entitlement to claim the priority of the earlier application (Rule 4.17(iii))

**Published:**

- with international search report (Art. 21(3))
- before the expiration of the time limit for amending the claims and to be republished in the event of receipt of amendments (Rule 48.2(h))

(54) **Title:** ELECTRICALLY CONDUCTIVE ADHESIVE

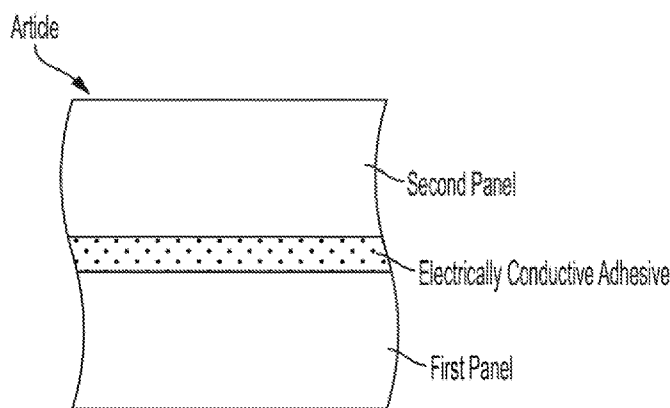

FIG. 5

(57) **Abstract:** Disclosed herein is an electrically conductive adhesive composition, articles comprising at least two components adhesively bonded by the electrically conductive adhesive composition and methods of making such adhesives and articles. The electrically conductive adhesive composition includes milled carbon fibers dispersed in a thermosetting resin and a curative agent.



**ELECTRICALLY CONDUCTIVE ADHESIVE**

## CROSS-REFERENCE TO RELATED APPLICATIONS

[0001] This Application is related to, and claims the benefit of priority of U.S. Provisional Application No. 62/649,054, entitled ELECTRICALLY CONDUCTIVE ADHESIVE, filed on 28 March 2018, the contents of which are incorporated herein by reference in their entirety for all purposes.

## FIELD OF THE INVENTION

[0002] The present disclosure relates generally to electrically conductive adhesive composition including milled carbon fibers dispersed in a thermosetting resin and a curative agent. The present disclosure also relates generally to articles comprising at least two components adhesively bonded by the electrically conductive adhesive composition and methods of making such adhesives and articles.

## BACKGROUND OF THE INVENTION

[0003] Many electrically conductive surfaces when bonded using an adhesive display good longitudinal or surface electrical conductivity, but poor through-thickness transverse electrical conductivity. Hence, there is a need for an improved electrically conductive adhesive for bonding electrically conductive surfaces and for improving the through-thickness transverse electrical conductivity of bonded surfaces.

## SUMMARY OF THE INVENTION

[0004] In an aspect, there is an electrically conductive adhesive composition comprising milled carbon fibers dispersed in a thermosetting resin and a curative agent.

[0005] In another aspect, there is an article comprising at least two components, where a portion of a first component is adhesively bonded to a portion of a second component using the electrically conductive adhesive composition of the present invention.

[0006] In yet another aspect, there is a spar cap comprising a plurality of fiber-reinforced resin composite sheets adhesively bonded to each other using the electrically conductive adhesive composition of the present invention, wherein each fiber-reinforced resin composite sheet comprises 50 to 80% by volume of carbon fibers fused with a binder resin, wherein the amount in % by volume is based on the total volume of the fiber-reinforced resin composite sheet.

[0007] In yet another aspect, there is a method comprising the steps of dispersing milled carbon fibers in a thermosetting resin to form a mixture and adding a curative agent to the mixture and optionally curing to form an electrically conductive adhesive.

## BRIEF DESCRIPTION OF THE DRAWINGS

[0008] The accompanying drawings, which are incorporated in and constitute a part of this specification, illustrate one (several) embodiment(s) of the invention, and together with the written description, serve to explain certain principles of the invention.

[0009] FIG. 1 shows a method of making an electrically conductive adhesive, in accordance with various embodiments of the present invention.

[0010] FIG. 2 shows another method of making an electrically conductive adhesive, in accordance with various embodiments of the present invention.

[0011] FIG. 3 shows results of difference in the mixing methods: without and with vacuum.

[0012] FIG. 4 shows a method of application of electrically conductive adhesive of the present invention on to a surface of a panel.

[0013] FIG. 5 shows a sectional view of a portion of an exemplary article comprising a composite panel, in accordance with various embodiments of the present invention.

[0014] FIG. 6 shows a sectional view of a portion of another exemplary article comprising a composite panel, in accordance with various embodiments of the present invention.

[0015] FIG. 7 shows an exemplary schematic sectional diagram of a portion of a spar cap, in accordance with various embodiments of the present invention.

[0016] FIG. 8 shows another exemplary schematic sectional diagram of a portion of a spar cap, in accordance with various embodiments of the present invention.

[0017] FIG. 9 shows an exemplary experimental set-up for measuring through thickness electrical conductivity in accordance to ANSI ANSI/ESD STM11.12.

[0018] FIG. 10 shows a graph showing through-thickness electrical conductivity of a composite panel comprising two pultruded sheets adhesively bonded by the electrically conductive adhesive of the present invention made by two different mixing methods, as a function of filler content, wherein each pultruded sheet comprises 20–80 % by volume of carbon fiber fused with a vinyl ester resin.

[0019] FIG. 11 shows a graph showing through-thickness electrical conductivity of a composite panel comprising two pultruded sheets adhesively bonded by the electrically conductive adhesive of the present invention, as a function of filler content, wherein each pultruded sheet comprises 20–80% by volume of carbon fiber.

[0020] FIG. 12 shows a graph showing through-thickness electrical conductivity of a composite panel comprising two pultruded sheets adhesively bonded by the electrically conductive adhesive of the present invention made by two different mixing

methods, as a function of filler content, wherein each pultruded sheet comprises 20–80 % by volume of carbon fiber fused with an epoxy resin.

[0021] FIG. 13 shows the results of an electrical strike in a non-conductive adhesive joint and a conductive adhesive joint.

5 [0022] FIG. 14 shows a picture of an exemplary C-section, in accordance with various embodiments of the present invention.

#### DETAILED DESCRIPTION OF THE INVENTION

[0023] Although the invention is illustrated and described herein with reference to specific embodiments, the invention is not intended to be limited to the details shown. Rather, various modifications may be made in the details within the scope and range of equivalents of the claims and without departing from the invention.

[0024] The wind energy industry requires lightning protection for the blades in which carbon fiber-reinforced resin composites have been commonly used for the spar caps. Procured carbon fiber-reinforced resin composites are typically bonded together in a stack using a binder resin which is not electrically conductive. Due to the strong anisotropy of the electrical conductivity of the carbon fibers and uni-directional planar tow form of these carbon fiber-reinforced resin composites, the lengthwise conductivity of these carbon fiber-reinforced resin composites can be four orders of magnitude higher than transverse conductivity. Hence, as a result of this anisotropy, during a lightning strike, the high energy electricity would flow lengthwise, but would arc transversely, which could result in elevation in temperature, and thereby can cause delamination or incineration of the spar cap. Therefore, it has been discovered that there is a need to effectively enhance the through-thickness transverse electrical conductivity of the carbon fiber-reinforced resin composites forming the spar cap. It has been contemplated to increase the electrical conductivity of materials by various techniques, such as:

- Incorporating nanomaterials in adhesives. However, nanomaterials are expensive and may require special precautions in handling further increasing COM, as powdered nanomaterials can be considered a hazardous material in some environments.
- Incorporating metal particles and/or metal coated particles in adhesives.
- Improving conductivities of prepreg materials rather than adhesives
- Some targeted film making
- Some targeted surface films and treatments

35 [0025] To the extent that these approaches have various issues, alternative approaches may be more efficient and cost effective for enhancing the electrical conductivity of adhesives. Further, enhancing the electrical conductivity of adhesives provides a way to assure electrical continuity through the entire thickness of a bonded

- 4 -

stack of plates in a spar cap. It is the objective of the present invention to effectively enhance the electrical conductivity of adhesives.

[0026] Disclosed herein is an electrically conductive adhesive composition, articles comprising at least two components adhesively bonded by the electrically  
5 conductive adhesive composition and methods of making thereof.

[0027] In an aspect, there is an electrically conductive adhesive composition comprising milled carbon fibers dispersed in a thermosetting resin and a curative agent. The milled carbon fibers can be present in an amount in the range of 2 to 40 weight%, or 1 to 50 weight%, based on the total weight of the electrically conductive  
10 adhesive composition.

[0028] In an embodiment, the adhesive composition has a linear conductivity in the range of  $10^{-14}$  –  $10^{-10}$  siemens/cm.

[0029] Any suitable milled carbon fibers can be used, whether they are milled from pristine carbon fibers or recycled carbon fibers. In an embodiment, the milled  
15 carbon fibers are recycled milled carbon fibers, free of sizing. As used herein, the phrase "recycled milled carbon fibers, free of sizing" refers to carbon fibers that end up as waste at some point in their lifecycle. The fiber source of the recycled milled carbon fibers could be fiber that was deemed unsuitable for continuous or chopped fiber product, fiber that was cut off during normal production of the fiber, or left over from  
20 the manufacturing process of carbon fiber intermediate products. Additionally, there is a little bit of fiber left over at the end of each fiber production run – that can be used as fiber source for making recycled milled carbon fiber. These wasted carbon fibers are stripped of any sizing that they might have had before being milled and converted into milled carbon fibers.

[0030] In an embodiment, the milled carbon fibers have an electrical resistivity of about 0.00155 Ohm-cm. The milled carbon fibers can have an average diameter in the range of 5 to 10 microns, and an average length in the range of 5 to 300 microns. In an embodiment, milled carbon fibers can have an average diameter of 7.2 microns and an average length of 100 microns. Suitable examples of commercially available  
30 milled carbon fibers include, but are not limited to: PX35MF0150, PX35MF0200, all available from Zoltek Corporation.

[0031] Any suitable thermosetting resin can be used, including, but not limited to at least one of epoxy resin, vinyl ester resins, phenolic resins (such as , phenolic formaldehyde (PF) resins, phenolic neoprene, resorcinol formaldehydes (RF)),  
35 unsaturated polyesters, thermoset polyurethanes, polyimides, bismaleimide resins, benzoxazine resins, silicone resins, and any combination, copolymer, and/or derivative thereof.

[0032] In an embodiment, the thermosetting resin is an epoxy resin. Some examples of commercially available thermosetting resin include, but are not limited to: Sikadur WTG-1280 Part A, available from Sika Corporation; Körapur 4W-Komp A, available from Kömmerling Corporation.

5 [0033] In another embodiment, the curative agent comprises an amine functional group. Some examples of commercially available curative agent include, but are not limited to: Sikadur WTG-1050 Part B, available from Sika Corporation; and Köracur 4W-Komp B available from Kömmerling Corporation.

10 [0034] In yet another embodiment, the thermosetting resin and the curative agent are available as a two component adhesive kit. Some examples of commercially available two component adhesive kit include, but are not limited to: Sikadur WTG-1280, available from Sika Corporation; and Körapur 4W available from Kömmerling Corporation.

[0035] In an embodiment, the electrically conductive adhesive composition of the present invention is suitable for use in the wind blade bonding applications.

[0036] The electrically conductive adhesive of the present disclosure could be used for various conductive bonding applications besides spar caps, such as the connection of the cables connecting the spar cap to the main down conductor cable that is part of the lightning protection system for the blade.

20 Method of Making An Adhesive Composition

[0037] In an aspect, there is a method comprising the steps of dispersing milled carbon fibers in a thermosetting resin to form a mixture, adding a curative agent to the mixture, followed by mixing thoroughly and optionally curing to form an electrically conductive adhesive. Any suitable mechanical means can be used for the step of dispersing milled carbon fibers in a thermosetting resin to form a mixture. In an embodiment, the step of adding curative agent to the mixture and mixing is done in air, or under inert environment. In another embodiment, the step of adding curative agent to the mixture and mixing is done under vacuum. The amount of time required for each mixing step will depend upon the composition and the mechanical means and can be in the range 30 seconds to 60 minutes.

30 Article

[0038] In another aspect, there is an article comprising at least two components, where a portion of a first component is adhesively bonded to a portion of a second component using the electrically conductive adhesive composition, as disclosed hereinabove.

[0039] Any suitable material can be used for the components. In one embodiment, at least one of the at least two components comprises a fiber-reinforced

resin composite. The fiber-reinforced resin composite may include a fiber and a binder resin.

[0040] In an embodiment of the fiber-reinforced resin composite, the fiber is a carbon fiber. In another embodiment, the fiber is an electrically conductive sized fiber.

5 [0041] In yet another embodiment, the fiber-reinforced resin composite comprises carbon fibers fused with a binder resin.

[0042] The fiber-reinforced resin composites according to the present invention may be formed from and based on any binder resin known in the art.

10 [0043] Non-limiting examples of a binder resin that is a thermoset (co)polymer includes unsaturated polyesters, epoxy resins, vinyl ester resins, phenolic resins, thermoset polyurethanes, polyimides, bismaleimide resins, benzoxazine resins, and silicone resins.

15 [0044] Non-limiting examples of a binder resin that is a thermoplastic (co)polymer includes, polyolefins, cyclic polyolefins, acrylonitrile butadiene styrene, polyvinyl chloride, polystyrene, thermoplastic polyesters, polyvinyl alcohols, polymethyl methacrylates, styrene maleic anhydrides, polyoxymethylene (acetals), thermoplastic polyurethanes, polyethylene terephthalates, polytrimethylene terephthalates, polybutylene terephthalates, polyamides, polycarbonates, polyvinylpyrrolidone, polytetrafluoroethylene, polysulfones, polyethersulfones, polyphenylene sulfides, 20 polyetherimides, polyamide-imides, polyetheretherketones, and polyaryletherketones, including alloys and blends.

[0045] In an embodiment, the fiber-reinforced resin composite is in the form of a pultruded sheet, a fabric, or a prepreg. In another embodiment, the fiber-reinforced resin composite in the form of a pultruded sheet includes carbon fibers in a planar tow 25 form fused with the binder resin. In yet another embodiment, the fiber-reinforced resin composite in the form of a fabric, with the fiber being a multidirectional fabric, a unidirectional fabric or a woven fabric.

30 [0046] In an embodiment, the fiber-reinforced resin composite includes at least one of 20–80% by volume of fiber reinforcement and a vinyl ester resin, 20–80% by volume of fiber reinforcement and a polyester resin or 20–80% by volume of fiber reinforcement and an epoxy resin, where the amount in % by volume is based on the total volume of the fiber-reinforced resin composite.

35 [0047] In an embodiment, the fiber-reinforced resin composite is in the form of a pultruded sheet, a resin-infused fabric, a pre-impregnated tape, or a sheet molding compound. In the pultruded form, the fiber may be present in an amount in the range of 40–80%, or preferably 60–72%, by volume, based on the total volume of the fiber-reinforced resin composite. In the pultruded form, the fiber may be present in an amount in the range of 40–80%, or preferably 60–72%, by volume, based on the total

volume of the fiber-reinforced resin composite. In the prepreg form, the fiber may be present in an amount in the range of 40-80%, or preferably 54-61%, by volume, based on the total volume of the fiber-reinforced resin composite. In the resin-infused fabric form, the fiber may be present in an amount in the range of 40-80%, or preferably 48-59%, by volume, based on the total volume of the fiber-reinforced resin composite.

[0048] The fiber-reinforced resin composite may also include any filler and/or particle, known in the art for reinforcing composites, such as polymer composites. Examples of such particles include, but are not limited to, talc, calcium carbonate, aluminum hydroxide, titanium oxides, and silica.

#### 10 Article

[0049] In an aspect, there is an article comprising at least two components adhesively bonded to each other using the electrically conductive adhesive composition, where at least one of the at least two components includes the fiber-reinforced resin composite, as disclosed hereinabove.

15 [0050] FIG. 5 shows a sectional view of a portion of an exemplary article comprising a composite panel, in accordance with various embodiments of the present invention. The exemplary composite panel includes two components, a first component adhesively bonded to a second component using the electrically conductive adhesive composition disposed between and in contact with the first component and the second component. In an embodiment, at least one of the two components comprises a fiber-reinforced resin composite.

[0051] FIG. 6 shows a sectional view of a portion of another exemplary article comprising a composite panel comprising a plurality of panels adhesively bonded to each other using the electrically conductive adhesive composition of the present disclosure. As shown in FIG. 6, the exemplary composite panel comprises at least four panels, a first panel is adhesively bonded to a second panel, the second panel adhesively bonded to a third panel and the third panel adhesively bonded to a fourth panel using the electrically conductive adhesive composition disposed between and in contact with the each panel. In an embodiment, the panels are stacked on top of each other such that at least one edge is slanted and has a slope. In an embodiment, at least one of the plurality of panels comprises a fiber-reinforced resin composite.

30 [0052] The composite panels of the present invention can have any suitable thickness, such as in the range of 0.5-30 mm.

[0053] In an embodiment, the article is a spar cap including a plurality of fiber-reinforced resin composite sheets adhesively bonded to each other using the electrically conductive adhesive composition of the present invention. FIG. 10 shows a schematic sectional diagram of a portion of a spar cap.



[0054] FIG. 7 shows an exemplary schematic sectional diagram of a portion of a spar cap, in accordance with various embodiments of the present invention. In particular, FIG. 7 shows a configuration of bonded plates in a spar cap.

[0055] FIG. 8 shows another exemplary schematic sectional diagram of a portion of a spar cap, in accordance with various embodiments of the present invention. In particular, FIG. 8 shows the use of the conductive adhesive to cover the end of the chamfer region of one plate and the surrounding surface area of the chamfered plate and the adjoining plate.

[0056] In an embodiment of the spar cap, the fiber-reinforced resin composite sheet comprises 20–80% by volume of carbon fibers fused with a vinyl ester resin. In another embodiment of the spar cap, the fiber-reinforced resin composite sheet comprises 20–80% by volume of fused with an epoxy resin. In another embodiment of the spar cap, the fiber-reinforced resin composite sheet comprises 20–80% by volume of fused with a polyester resin. In yet another embodiment of the spar cap, at least one of the plurality of fiber-reinforced resin composite sheets is a pultruded sheet comprising 40-80%, or preferably 60-72%, by volume of fiber, based on the total volume of the fiber-reinforced resin composite.

[0057] In an embodiment, there is an article comprising at least two components, where a portion of a first component is adhesively bonded to a portion of a second component by an electrically conductive adhesive of the present disclosure. In an embodiment, the article is a spar cap and the two components form a chamfer region. In another embodiment, the article further comprises the electrically conductive adhesive disposed over at least one of the at least two components. In yet another embodiment, the electrically conductive adhesive extends beyond the chamfer region onto both surfaces of the adjoining components.

[0058] It is believed that the electrical conductivity would be maintained between the adhesively bonded fiber-reinforced resin composite sheets using the conductive adhesive composition of the present application, thereby minimizing the arcing phenomenon. The resulting spar cap of the present invention will be far more lightning resistant than one without a conductive interlayer between the fiber-reinforced resin composite sheets.

#### Method of Making a Composite Panel

[0059] In an aspect, there is a method comprising applying the electrically conductive adhesive on a portion of a surface of a first panel; and adhesively bonding a second panel to the first panel, such that the electrically conductive adhesive is disposed between the first and the panel to form a composite panel. Any suitable method can be used for the application of adhesive, including but not limited to spray, web coating, wheel or brush coating. The method of application is based on specific

composition of the electrically conductive adhesive, the nature of the panels and production requirements. The method can further include curing the composite panel. The curing can be done thermally or photochemically, depending upon the nature of the curative agent present in the adhesive composition. The curing can be done in air, under inert environment or under vacuum.

[0060] In an embodiment, at least one of the first or the second panel comprises a fiber-reinforced resin composite, as disclosed hereinabove.

[0061] In an aspect, the method may further include forming a fiber-reinforced resin composite in the form of a pultruded sheet or a resin-infused fabric, or a pre-impregnated tape (prepreg, impregnated with a thermoplastic resin or a thermosetting resin), or a sheet molding compound (SMC). In an embodiment, the step of forming a fiber-reinforced resin composite can include arranging a fiber into a fabric and infusing the fabric with a binder resin to form a resin infused fabric or a prepreg. In another embodiment, the step of forming a fiber-reinforced resin composite can include arranging a fiber into a planar tow form, infusing the planar tow form with a binder resin and pultruding the resin infused planar tow form to form a pultruded sheet.

[0062] In another embodiment, the step of forming a fiber-reinforced resin composite can include arranging a combination of a fiber and a fabric into a structural cross section form, infusing the structural cross section form with a binder resin and pultruding the resin infused section form to result in a pultruded structural section (for example a C-section, J-section, or Pi-section). Figure 14 shows a picture of an exemplary C-section, in accordance with various embodiments of the present invention.

[0063] In another embodiment, the step of forming a fiber-reinforced resin composite can include compounding at least one of a plurality of chopped or a plurality of continuous fibers with a binder resin and compression molding or injection molding the resulting composition into an article.

[0064] In another embodiment, the method may include a step of making a composite panel in the form of a spar cap.

[0065] In an embodiment, the electrically conductive adhesive composition of the present invention is suitable for use in the wind blade applications.

[0066] The use of the electrically conductive adhesive composition of the present invention in adhesively bonding at least two components, provides several advantages over conventional adhesives, including, but not limited to:

- Low cost, as the milled fiber is much less expensive than the nanomaterials, as disclosed in the prior art. The characteristic dimension of nanoparticles is not needed for this application and hence would be an unnecessary cost burden. Furthermore, no special precautions must be taken with the powdered form of

- 10 -

milled carbon fiber. In contrast, powdered nanomaterials can be considered a hazardous material in some environments.

- Due to their aspect ratio, the milled fibers impart some structural/mechanical benefit to the adhesive.

5 

- Milled carbon fiber assures perfect compatibility with the carbon plates being bonded.

- Relatively low levels of milled carbon fiber are needed to assure electrical continuity through the thickness of a stack of carbon plates, as shown in FIGS. 7-9.

10 

- For the 2-part adhesive, the milled fiber can be premixed into the Part A (resin component), thereby providing to the user a 2 part electrically conductive adhesive. Hence, the user will maintain a common process when mixing and using the 2 part electrically conductive adhesive. Additionally, this enables point-of-use mixing with automatic mixing tube applicators.

15 

- For the wind blade manufacturing application, using the two-part adhesives already used provides maintenance of the process familiarity, mechanical bonding properties, and handling characteristics.

20 

- In contrast to all other known approaches, the present invention discloses the use of milled carbon fiber as the conductive filler. By using the resulting conductive adhesive in the lamination of procured carbon composites, the electrical conductivity reduces the flash over of electricity between layers during a lightning strike event in wind turbine blades.

[0067] More specifically, the following represents particular embodiments of the invention:

1. An electrically conductive adhesive composition comprising:

25 

- a) milled carbon fibers dispersed in a thermosetting resin; and
- b) a curative agent.

2. The electrically conductive adhesive composition according to embodiment 1, wherein the thermosetting resin is an epoxide resin.

30 3. The electrically conductive adhesive composition according to embodiments 1 or 2, wherein the curative agent comprises an amine functional group.

4. The electrically conductive adhesive composition according to any one of the preceding embodiments, wherein the thermosetting resin comprises at least one of epoxy resin, vinyl ester resins, phenolic resins, unsaturated polyesters, thermoset polyurethanes, polyimides, bismaleimide resins, benzoxazine resins, 35 silicone resins, and any combination, copolymer, and/or derivative thereof.

5. The electrically conductive adhesive composition according to any one of the preceding embodiments, wherein the milled carbon fibers are present in an

- 11 -

amount in the range of 1 to 20 weight%, based on the total weight of the electrically conductive adhesive composition

6. The electrically conductive adhesive composition according to any one of the preceding embodiments, wherein the milled carbon fibers have an average diameter in the range of 5 to 10 microns and an average length in the range of 1 to 300 microns.
7. The electrically conductive adhesive composition according to any one of the preceding embodiments, wherein the adhesive composition has a linear conductivity in the range of  $10^{-14}$  –  $10^{-10}$  siemens/cm.
8. The electrically conductive adhesive composition of according to any one of the preceding embodiments, wherein the milled carbon fibers are free of sizing.
9. The electrically conductive adhesive composition of according to any one of the preceding embodiments, wherein the milled carbon fibers are pristine or recycled milled carbon fibers, free of sizing.
10. An article comprising at least two components, where a portion of a first component is adhesively bonded to a portion of a second component using the electrically conductive adhesive composition according to any one of the embodiments 1-9.
11. The article according to embodiment 10, wherein at least one of the at least two components comprises a fiber-reinforced resin composite.
12. The article according to embodiment 11, wherein the fiber-reinforced resin composite comprises carbon fibers fused with a binder resin.
13. The article according to embodiment 10, wherein at least one of the at least two components is in the form of a pultruded sheet, a resin-infused fabric, a pre-impregnated tape, or a sheet molding compound.
14. The article according to embodiment 12, wherein the pultruded sheet comprises carbon fibers in a planar tow form fused with a binder resin.
15. The article according to embodiment 12, wherein the binder resin comprises a thermosetting binder resin chosen from among unsaturated polyesters, epoxy resins, vinyl ester resins, phenolic resins, thermoset polyurethanes, polyimides, bismaleimide resins, benzoxazine resins, and silicone resins.
16. The article according to embodiment 12, wherein the binder resin comprises a thermoplastic binder resin chosen from among polyolefins, cyclic polyolefins, acrylonitrile butadiene styrene, polyvinyl chloride, polystyrene, thermoplastic polyesters, polyvinyl alcohols, polymethyl methacrylates, styrene maleic anhydrides, polyoxymethylene (acetals), thermoplastic polyurethanes, polyethylene terephthalates, polytrimethylene terephthalates, polybutylene terephthalates, polyamides, polycarbonates, polyvinylpyrrolidone,

polytetrafluoroethylene, polysulfones, polyethersulfones, polyphenylene sulfides, polyetherimides, polyamide-imides, polyetheretherketones, and polyaryletherketones, including alloys and blends.

17. The article according to any one of embodiments 13, wherein the fabric  
5 comprises a multidirectional fabric, a unidirectional fabric or a woven fabric.
18. The article according to embodiment 13, wherein the pultruded sheet comprises at least one of:
- a) 20-80% by volume of carbon fibers fused with a vinyl ester resin, or
  - b) 20-80% by volume of carbon fibers fused with an epoxy resin,
- 10 wherein the amount in % by volume is based on the total volume of the fiber-reinforced resin composite.
19. A spar cap comprising a plurality of fiber-reinforced resin composite sheets adhesively bonded to each other using the adhesive composition according to any one of the embodiments 1-9,  
15 wherein each fiber-reinforced resin composite sheet comprises 50 to 80 % by volume of carbon fibers fused with a binder resin, wherein the amount in % by volume is based on the total volume of the fiber-reinforced resin composite sheet.
20. The spar cap according to embodiment 19, wherein the fiber-reinforced resin composite sheet comprises 20-80% by volume of carbon fibers fused with a vinyl ester resin.
21. The spar cap according to embodiment 19, wherein the fiber-reinforced resin composite sheet comprises 20-80% by volume of carbon fibers fused with an epoxy resin.
- 25 22. A method comprising:
- a) dispersing milled carbon fibers in a thermosetting resin to form a mixture; and
  - b) adding a curative agent to the mixture and optionally curing to form an electrically conductive adhesive.
- 30 23. The method according to embodiment 22 wherein the step of dispersing milled carbon fibers in a thermosetting resin to form a mixture is done mechanically.
24. The method according to embodiment 23, wherein the step of adding a curative agent to the mixture further comprises mixing under vacuum.
25. The method according to according to any one of the embodiments 22-24,  
35 further comprising:
- a) applying the electrically conductive adhesive on a portion of a surface of a first component; and

- 13 -

b) adhesively bonding a second component to the first component, such that the electrically conductive adhesive is disposed between the first and the components to form a composite panel.

26. The method according to embodiment 25, wherein at least one of the first or the second components comprises a fiber-reinforced resin composite.

27. The method according to embodiment 26, wherein the fiber-reinforced resin composite comprises carbon fibers fused with a binder resin.

28. The method according to embodiment 26, wherein the fiber-reinforced resin composite is in the form of a pultruded sheet, a resin-infused fabric, a pre-impregnated tape, or a sheet molding compound.

29. The method according to embodiment 28, wherein the pultruded sheet comprises carbon fibers in a planar tow form fused with a binder resin.

30. The method according to embodiment 27, wherein the binder resin comprises a thermosetting binder resin chosen from among unsaturated polyesters, epoxy resins, vinyl ester resins, phenolic resins, thermoset polyurethanes, polyimides, bismaleimide resins, benzoxazine resins, and silicone resins.

31. The method according to embodiment 27, wherein the binder resin comprises a thermoplastic binder resin chosen from among polyolefins, cyclic polyolefins, acrylonitrile butadiene styrene, polyvinyl chloride, polystyrene, thermoplastic polyesters, polyvinyl alcohols, polymethyl methacrylates, styrene maleic anhydrides, polyoxymethylene (acetals), thermoplastic polyurethanes, polyethylene terephthalates, polytrimethylene terephthalates, polybutylene terephthalates, polyamides, polycarbonates, polyvinylpyrrolidone, polytetrafluoroethylene, polysulfones, polyethersulfones, polyphenylene sulfides, polyetherimides, polyamide-imides, polyetheretherketones, and polyaryletherketones, including alloys and blends.

32. The method according to embodiment 28, wherein the fabric comprises a multidirectional fabric, a unidirectional fabric or a woven fabric.

33. The method according to embodiment 28, wherein the pultruded sheet comprises 20-80% by volume carbon fibers, based on the total volume of the fiber-reinforced resin composite.

34. The method according to embodiment 28, wherein the fiber-reinforced resin composite is in a form of a pultruded sheet comprising 20-80% by volume of carbon fibers fused with a vinyl ester resin.

35. The method according to embodiment 28, wherein the fiber-reinforced resin composite is in a form of a pultruded sheet comprising 20-80% by volume of carbon fibers fused with an epoxy resin.

36. The method according to any one of the embodiments 25-35, wherein the composite panel is in the form of a spar cap.

37. An article comprising at least two components, where a portion of a first component is adhesively bonded to a portion of a second component by an electrically conductive adhesive according to any one of the embodiments 1-9.

38. The article of claim 37 wherein the article is a spar cap and wherein the two components forms a chamfer region.

39. The article according to embodiment 37, further comprising the electrically conductive adhesive disposed over at least one of the at least two components.

40. The article according to embodiment 38, and wherein the electrically conductive adhesive extends beyond the chamfer region onto both surfaces of the adjoining components.

[0068] The invention will be further explained by the following Examples, which are intended to be purely exemplary of the invention, and should not be considered as limiting the invention in any way.

#### EXAMPLES

##### **Materials used:**

[0069] Thermosetting epoxy resin available as Sikadur WTG-1280 (Part A) and curative agent available as Sikadur WTG-1050 (Part B), were obtained from Sika Corporation. ZOLTEK PX35 MF200 milled fibers ( $\sim 5\mu\text{m}$  to  $150\mu\text{m}$  in length by  $\sim 7\mu\text{m}$  in diameter) were obtained from Zoltek Corporation. All materials were used as is.

##### **Pultruded profiles used:**

[0070] Profiles of pultruded sheet used in the examples below:

- 62% Fiber Volume Fraction (FVF) carbon fiber with 38% Vinyl ester
- 72% FVF carbon fiber with 28% Epoxy resin

##### **Testing Methods:**

[0071] Volume (through-thickness) electrical conductivity can be determined from electrical resistance per ANSI ANSI/ESD STM11.12, using a PROSTAT® PRS-801 Resistance System or similar instrument and PROSTAT PRF-911 Concentric Ring or similar apparatus, as shown in FIG. 9.

##### **Basic Process:**

[0072] Step 1: Method of Making an Electrically Conductive Adhesive as shown in FIGS. 1 and 2

[0073] Milled carbon fibers (PX35 MF200) were mixed into a thermosetting epoxy resin (Part A, Sikadur WTG-1280) of the two part adhesive. The milled carbon fibers were added in various amounts in the range of 2-37.5 weight%, based on the total weight of the adhesive composition. The mixing was done until the two components were thoroughly combined to form a uniform mixture. Then, the curative

**agent**/hardener portion (Part B, Sikadur WTG-1050) was added to the Part A/milled fiber mixture in a 50:50 ratio, according to the manufacturer's instructions, and mixed until thoroughly combined to form an electrically conductive adhesive.

[0074] As shown in FIGS. 1 and 2, the step of mixing of the Part A/milled fiber mixture with Part B can be done in air or partially under vacuum. FIG. 3 shows the difference between when the mixing is done in air versus when the step of mixing of the Part A/milled fiber mixture with Part B was done under vacuum. As is clear from FIG. 3, the mixing under vacuum provides certain advantages over when carried out in air, such as uniform mixing and no air bubbles. Air bubbles can be detrimental to attaining a thin uniform layer of adhesive over a panel.

[0075] Step 2: Method of Making a Composite Panel as shown in FIGS. 4-6

[0076] A pultruded composite panel was formed by first applying the fully mixed electrically conductive adhesive as a thin even layer on one side of one of a first pultruded plates (62% Vf Vinyl ester or 72% Vf Epoxy resin), as shown in FIG. 4. Then, the second pultruded plate is placed on top of the adhesive layer of the first pultruded plate to form a bonded stack of pultrude composite panel, as shown in FIG. 5.

[0077] This process of applying a thin layer of electrically conductive adhesive and adding subsequent plates to form a bonded stack of pultruded composite panel can be continued for as many panels as desired, as shown in FIG. 6.

[0078] The bonded stack of pultruded composite panels was cured under vacuum at the adhesive supplier's recommended cure cycle of curing under vacuum at 70°C for 5 hours.

[0079] Electrical conductivity testing was performed on composite panels to confirm dramatic improvement in conductivity through the thickness of the stack, as shown in FIGS. 10-12.

[0080] FIG. 10 shows a graph showing through-thickness electrical conductivity of a composite panel comprising two pultruded sheets adhesively bonded by the electrically conductive adhesive of the present invention made by two different mixing methods (regular mixing versus mixing done using a Resodyn LabRam model ResonantAcoustic® Mixer (RAM)), as a function of filler content, wherein each pultruded sheet comprises 62% by volume of carbon fiber fused with a vinyl ester resin. As can be seen in FIG. 10, the electrical conductivity of composite panel formed using ResonantAcoustic® mixer had lower conductivity as compared to one done in air, even though the mixing under vacuum resulted in uniform mixture with no air bubbles. This discrepancy was due to a portion of part B being stuck on the walls of the LabRam mixer resulting in an amount ratio of curative agent/hardener portion (Part B, Sikadur



WTG-1050) to the Part A/milled fiber mixture different from supplier suggested 50:50 ratio.

[0081] FIG. 11 shows a graph showing through-thickness electrical conductivity of a composite panel comprising two pultruded sheets adhesively bonded by the electrically conductive adhesive of the present disclosure, as a function of filler content, where each pultruded sheet comprises 62% by volume of carbon fiber.

[0082] FIG. 12 shows a graph showing through-thickness electrical conductivity of a composite panel comprising two pultruded sheets adhesively bonded by the electrically conductive adhesive of the various embodiments of the present disclosure, made by two different mixing methods, as a function of filler content, wherein each pultruded sheet comprises 72% by volume of carbon fiber fused with an epoxy resin.

[0083] FIGS. 11 and 12 shows that irrespective of the composition of fiber-reinforced composite, the adhesive composition provided a surprising and dramatic increase in the electrical conductivity measured through stack, as compared to neat adhesive and reaches close to that of single panel (single profile).

[0084] FIG. 13 compares the effect of using the conductive adhesive to chamfer region of two plates. The first panel in the FIG. 13 shows the results of a non-conductive joint when struck by electrical energy. The energy arcs from both the nearby surface of one plate (a) to the nearby surface of the second plate (b) and through the non-conductive adhesive layer itself.

[0085] The second panel in the FIG. 13 shows the results of the same electrical strike in a conductively bonded joint. In this panel, the electricity arcs using only one path only from nearby surface to nearby surface of the two plates. As shown in FIG. 13, the conductive joint shows no damage from the strike. A method of applying the conductive adhesive to the surface area of each plate adjacent to the joint and the chamfer will reduce the potential for arcing near the joint.

[0086] It will be apparent to those skilled in the art that various modifications and variations can be made in the practice of the present invention without departing from the scope or spirit of the invention. Other embodiments of the invention will be apparent to those skilled in the art from consideration of the specification and practice of the invention. It is intended that the specification and examples be considered as exemplary only, with a true scope and spirit of the invention being indicated by the following claims.

## What is Claimed:

1. An electrically conductive adhesive composition comprising:  
milled carbon fibers dispersed in a thermosetting resin; and  
a curative agent.
- 5 2. The electrically conductive adhesive composition according to claim 1,  
wherein the thermosetting resin is an epoxide resin.
3. The electrically conductive adhesive composition according to claim 1 or  
claim 2, wherein the curative agent comprises an amine functional group.
4. The electrically conductive adhesive composition according to any one of  
10 the preceding claims, wherein the thermosetting resin comprises at least one of epoxy  
resin, vinyl ester resins, phenolic resins, unsaturated polyesters, thermoset  
polyurethanes, polyimides, bismaleimide resins, benzoxazine resins, silicone resins, and  
any combination, copolymer, and/or derivative thereof.
5. The electrically conductive adhesive composition according to any one of  
15 the preceding claims, wherein the milled carbon fibers are present in an amount in the  
range of 1 to 20 weight%, based on the total weight of the electrically conductive  
adhesive composition
6. The electrically conductive adhesive composition according to any one of  
the preceding claims, wherein the milled carbon fibers have an average diameter in the  
20 range of 5 to 10 microns and an average length in the range of 1 to 300 microns.
7. The electrically conductive adhesive composition according to any one of  
the preceding claims, wherein the adhesive composition has a linear conductivity in the  
range of  $10^{-14}$  to  $10^{-10}$  siemens/cm.
8. The electrically conductive adhesive composition according to any one of  
25 the preceding claims, wherein the milled carbon fibers are free of sizing.
9. The electrically conductive adhesive composition according to any one of  
the preceding claims, wherein the milled carbon fibers are pristine or recycled milled  
carbon fibers, free of sizing.
10. An article comprising at least two components, where a portion of a first  
30 component is adhesively bonded to a portion of a second component using the  
electrically conductive adhesive composition according to any one of claims 1-9.
11. The article according to claim 10, wherein at least one of the at least two  
components comprises a fiber-reinforced resin composite.
12. The article according to claim 11, wherein the fiber-reinforced resin  
35 composite comprises carbon fibers fused with a binder resin.

13. The article according to claim 10, wherein at least one of the at least two components is in the form of a pultruded sheet, a resin-infused fabric, a pre-impregnated tape, or a sheet molding compound.

14. The article according to claim 12, wherein the pultruded sheet comprises  
5 carbon fibers in a planar tow form fused with a binder resin.

15. The article according to claim 12, wherein the binder resin comprises a thermosetting binder resin chosen from among unsaturated polyesters, epoxy resins, vinyl ester resins, phenolic resins, thermoset polyurethanes, polyimides, bismaleimide resins, benzoxazine resins, and silicone resins.

16. The article according to claim 12, wherein the binder resin comprises a  
10 thermoplastic binder resin chosen from among polyolefins, cyclic polyolefins, acrylonitrile butadiene styrene, polyvinyl chloride, polystyrene, thermoplastic polyesters, polyvinyl alcohols, polymethyl methacrylates, styrene maleic anhydrides, polyoxymethylene (acetals), thermoplastic polyurethanes, polyethylene terephthalates,  
15 polytrimethylene terephthalates, polybutylene terephthalates, polyamides, polycarbonates, polyvinylpyrrolidone, polytetrafluoroethylene, polysulfones, polyethersulfones, polyphenylene sulfides, polyetherimides, polyamide-imides, polyetheretherketones, and polyaryletherketones, including alloys and blends.

17. The article according to any one of claims 13-16, wherein the fabric  
20 comprises a multidirectional fabric, a unidirectional fabric or a woven fabric.

18. The article according to claim 13, wherein pultruded sheet comprises at least one of:

- a) 20-80% by volume of carbon fibers fused with a vinyl ester resin,  
or
- 25 b) 20-80% by volume of carbon fibers fused with an epoxy resin,  
wherein the amount in % by volume is based on the total volume of the fiber-reinforced resin composite.

19. A spar cap comprising a plurality of fiber-reinforced resin composite sheets adhesively bonded to each other using the adhesive composition according to  
30 any one of claims 1-9,

wherein each fiber-reinforced resin composite sheet comprises 50 to 80 % by volume of carbon fibers fused with a binder resin, wherein the amount in % by volume is based on the total volume of the fiber-reinforced resin composite sheet.

20. The spar cap according to claim 19, wherein the fiber-reinforced resin  
35 composite sheet comprises 20-80% by volume of carbon fibers fused with a vinyl ester resin.

21. The spar cap according to claim 19, wherein the fiber-reinforced resin composite sheet comprises 20-80% by volume of carbon fibers fused with an epoxy resin.

22. A method comprising the steps of:

- a) dispersing milled carbon fibers in a thermosetting resin to form a mixture; and
- b) adding a curative agent to the mixture and optionally curing to form an electrically conductive adhesive.

23. The method according to claim 22 wherein the step of dispersing milled carbon fibers in a thermosetting resin to form a mixture is done mechanically.

24. The method according to claim 23, wherein the step of adding a curative agent to the mixture further comprises mixing under vacuum.

25. The method according to any one of claims 22-24, further comprising

- c) applying the electrically conductive adhesive on a portion of a surface of a first component; and
- d) adhesively bonding a second component to the first component, such that the electrically conductive adhesive is disposed between the first and the components to form a composite panel.

26. The method according to claim 25, wherein at least one of the first or the second components comprises a fiber-reinforced resin composite.

27. The method according to claim 26, wherein the fiber-reinforced resin composite comprises carbon fibers fused with a binder resin.

28. The method according to claim 26, wherein the fiber-reinforced resin composite is in the form of a pultruded sheet, a resin-infused fabric, a pre-impregnated tape, or a sheet molding compound.

29. The method according to claim 28, wherein the pultruded sheet comprises carbon fibers in a planar tow form fused with a binder resin.

30. The method according to claim 27, wherein the binder resin comprises a thermosetting binder resin chosen from among unsaturated polyesters, epoxy resins, vinyl ester resins, phenolic resins, thermoset polyurethanes, polyimides, bismaleimide resins, benzoxazine resins, and silicone resins.

31. The method according to claim 27, wherein the binder resin comprises a thermoplastic binder resin chosen from among polyolefins, cyclic polyolefins, acrylonitrile butadiene styrene, polyvinyl chloride, polystyrene, thermoplastic polyesters, polyvinyl alcohols, polymethyl methacrylates, styrene maleic anhydrides, polyoxymethylene (acetals), thermoplastic polyurethanes, polyethylene terephthalates, polytrimethylene terephthalates, polybutylene terephthalates, polyamides,

polycarbonates, polyvinylpyrrolidone, polytetrafluoroethylene, polysulfones, polyethersulfones, polyphenylene sulfides, polyetherimides, polyamide-imides, polyetheretherketones, and polyaryletherketones, including alloys and blends.

32. The method according to claim 28, wherein the fabric comprises a  
5 multidirectional fabric, a unidirectional fabric or a woven fabric.

33. The method according to claim 28, wherein the pultruded sheet comprises 20-80% by volume carbon fibers, based on the total volume of the fiber-reinforced resin composite.

34. The method according to claim 28, wherein the fiber-reinforced resin  
10 composite is in a form of a pultruded sheet comprising 20-80% by volume of carbon fibers fused with a vinyl ester resin.

35. The method according to claim 28, wherein the fiber-reinforced resin composite is in a form of a pultruded sheet comprising 20-80% by volume of carbon fibers fused with an epoxy resin.

15 36. The method according to any one of claims 25-35, wherein the composite panel is in the form of a spar cap.

37. An article comprising at least two components, where a portion of a first component is adhesively bonded to a portion of a second component by an electrically conductive adhesive according to any one of claims 1-9.

20 38. The article according to claim 37 wherein the article is a spar cap and wherein the two components forms a chamfer region.

39. The article according to claim 37, further comprising the electrically conductive adhesive disposed over at least one of the at least two components.

25 40. The article according to claim 38, and wherein the electrically conductive adhesive extends beyond the chamfer region onto both surfaces of the adjoining components.

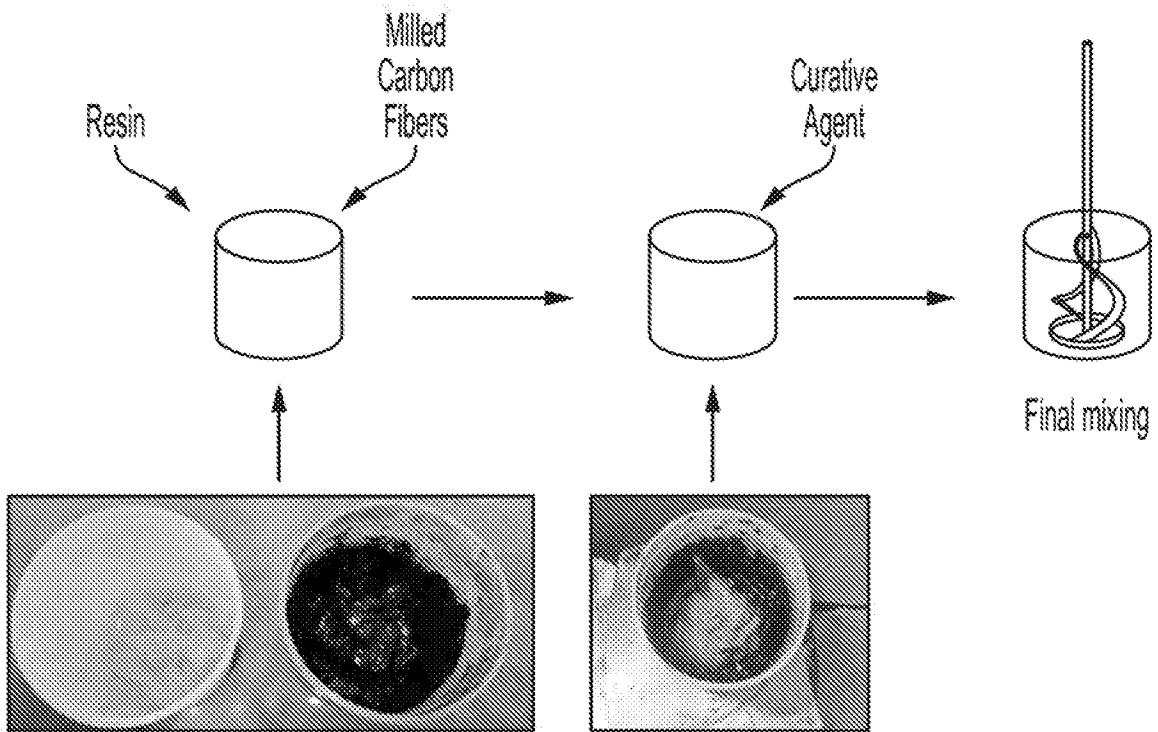

FIG. 1

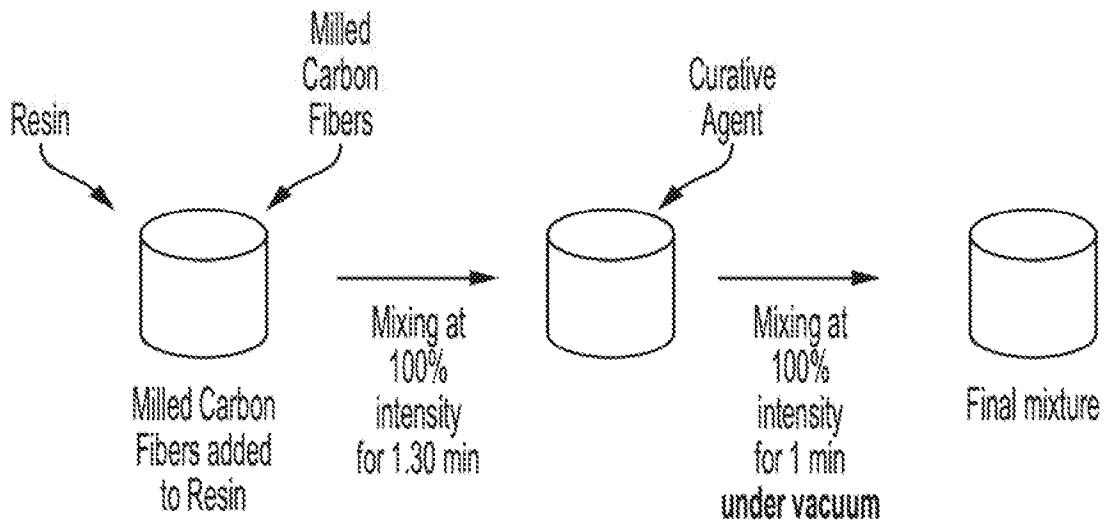

FIG. 2



FIG. 3

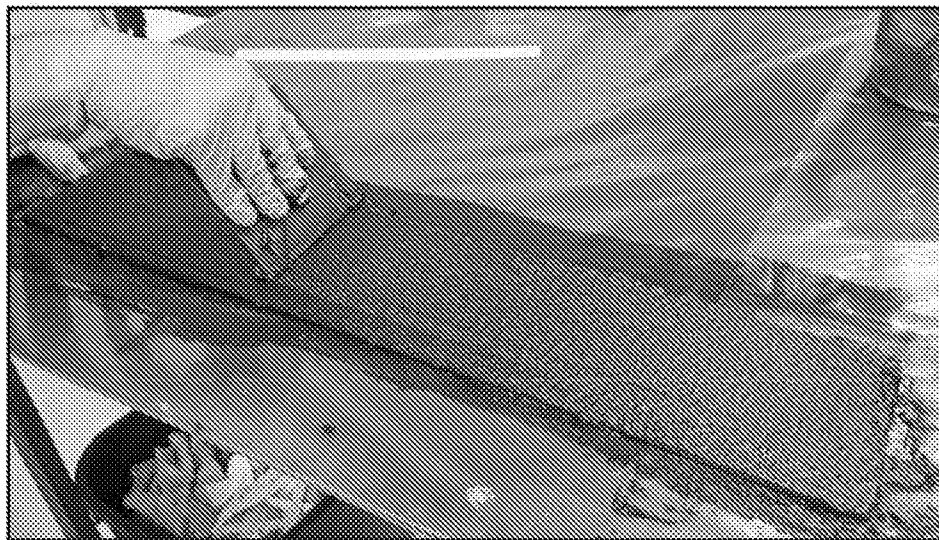

FIG. 4

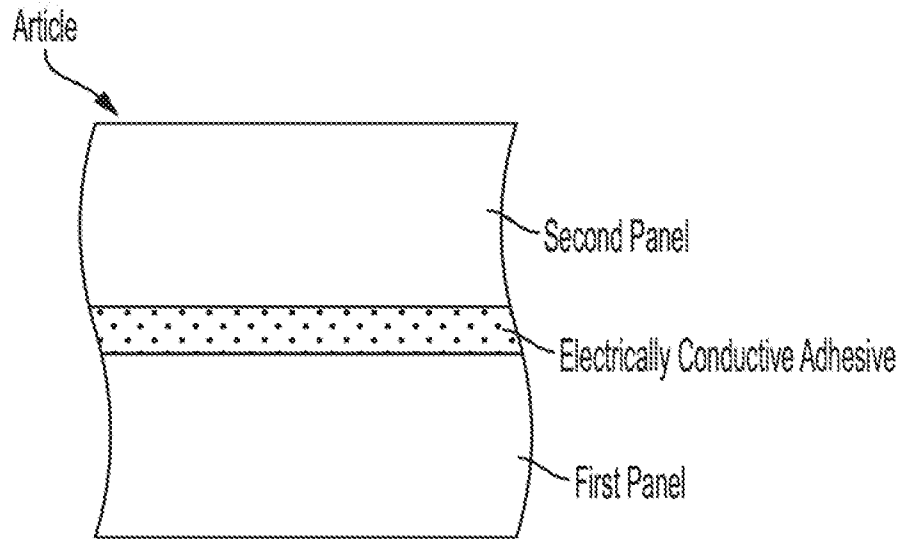

FIG. 5

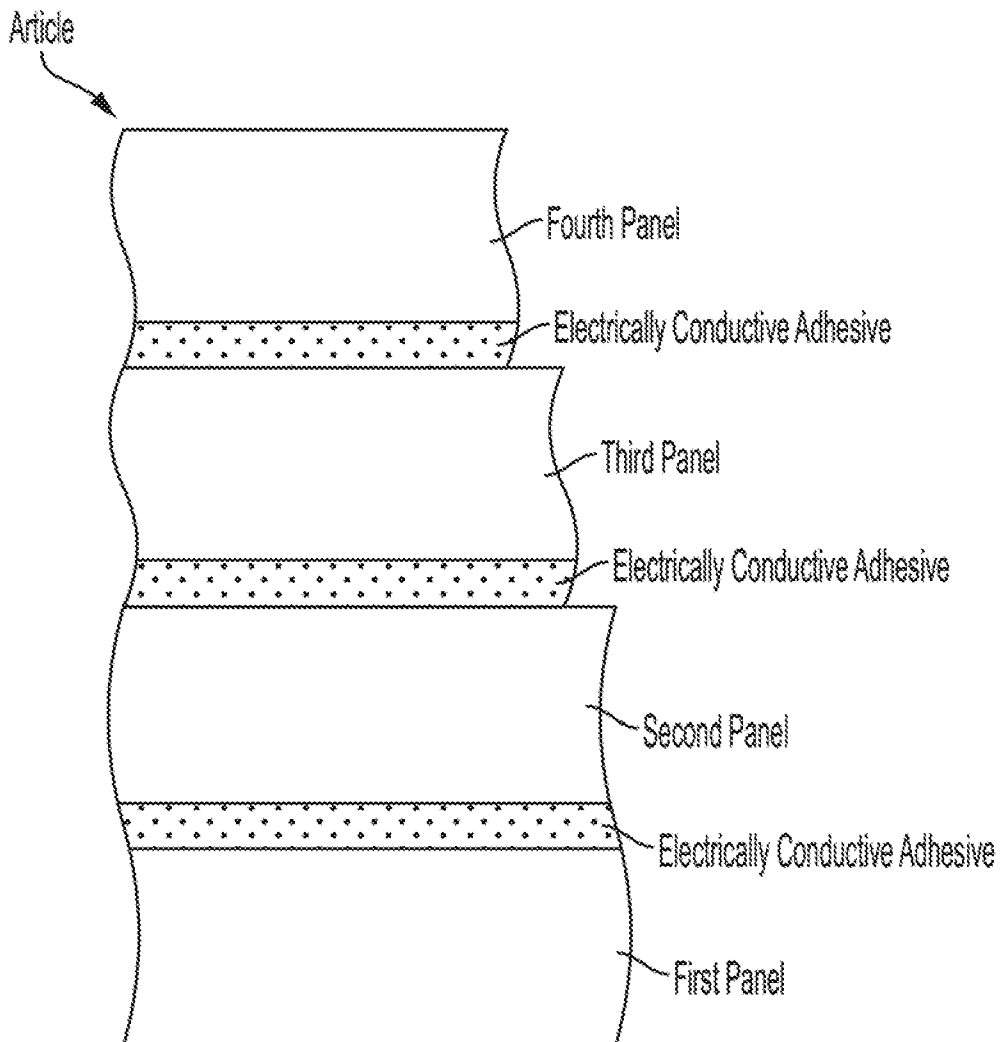

FIG. 6



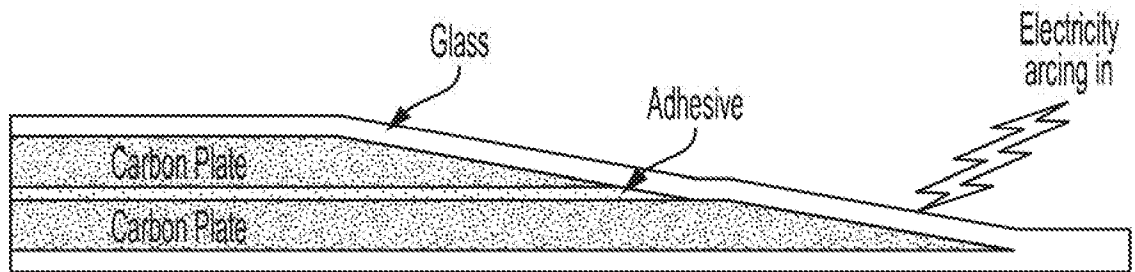
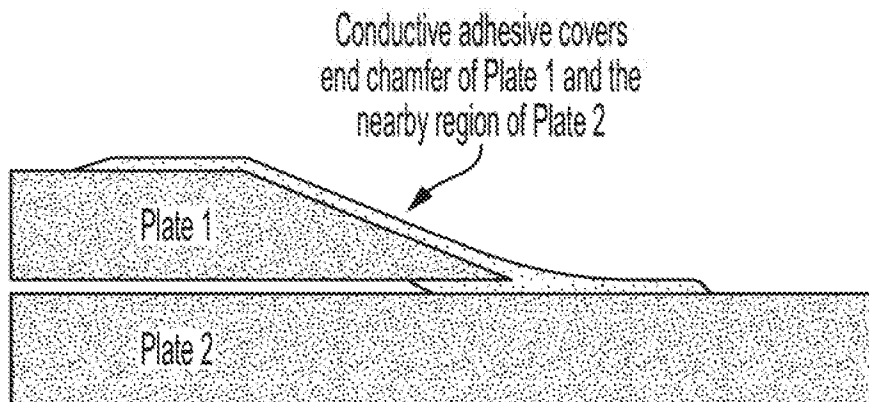

FIG. 7



Using the conductive adhesive to cover the exposed chamfer regions and nearby surface of adjoining plate resists electrical arcing at ply drop-off

FIG. 8

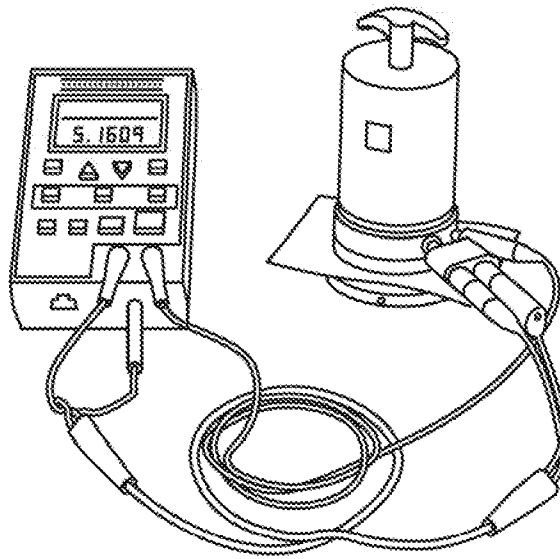

FIG. 9

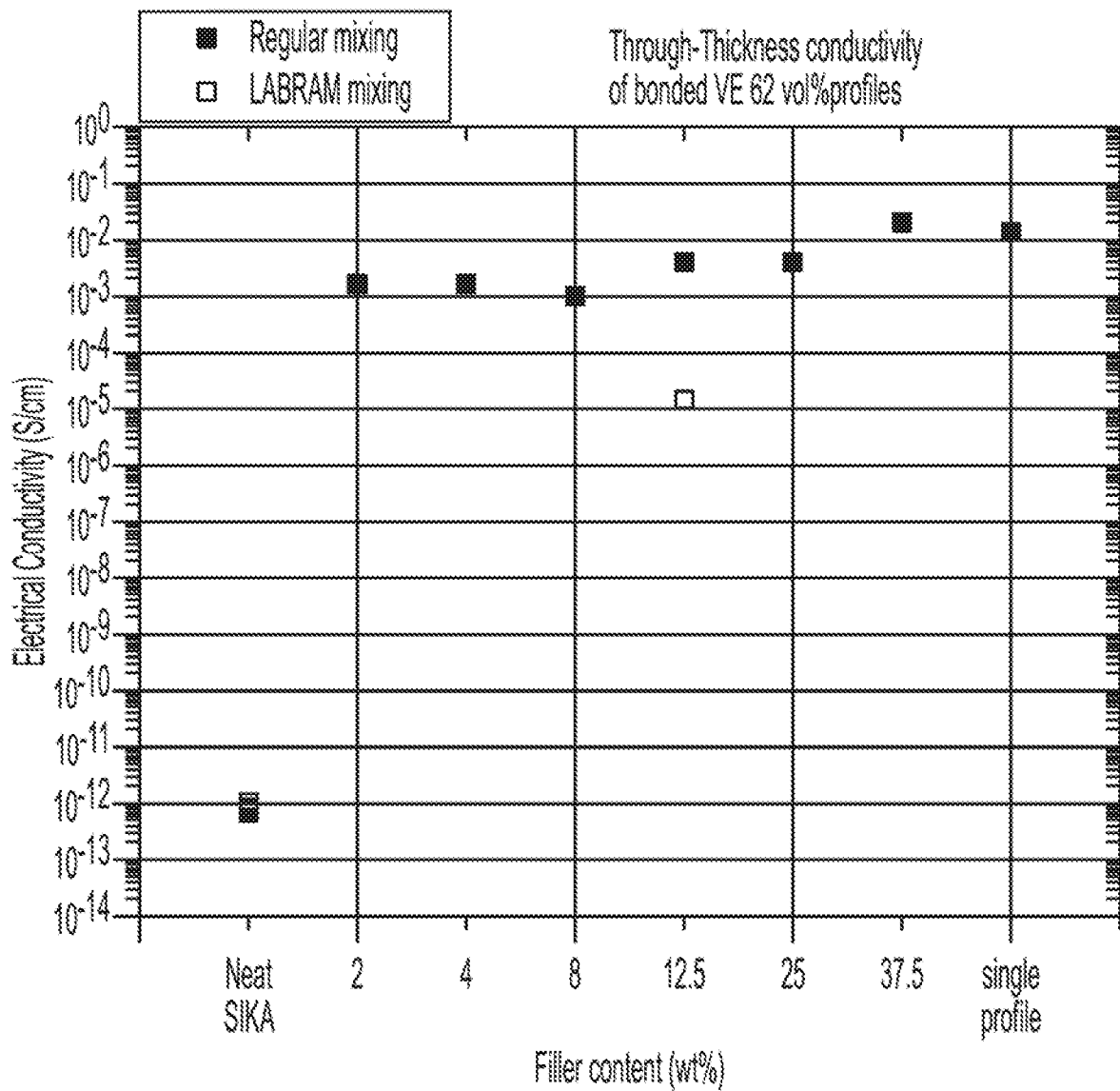

FIG. 10

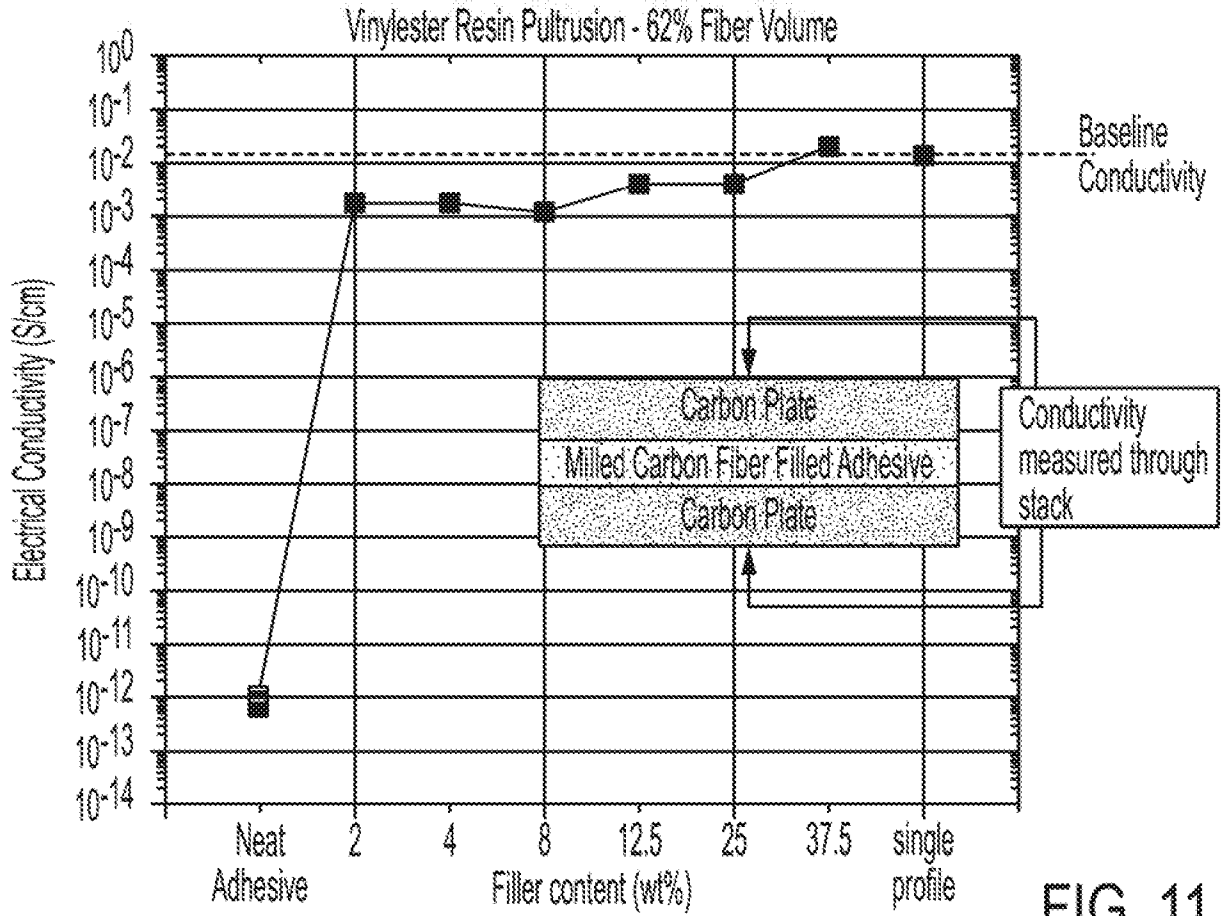

FIG. 11

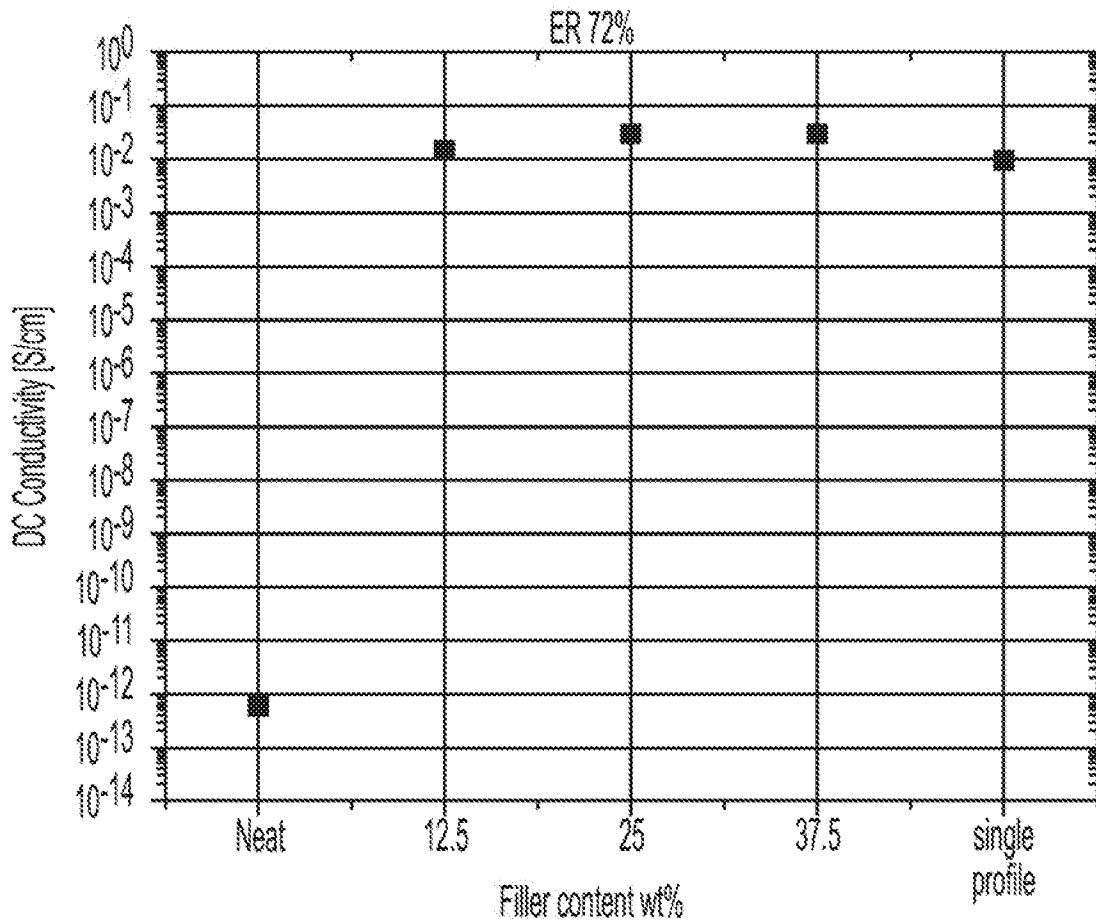
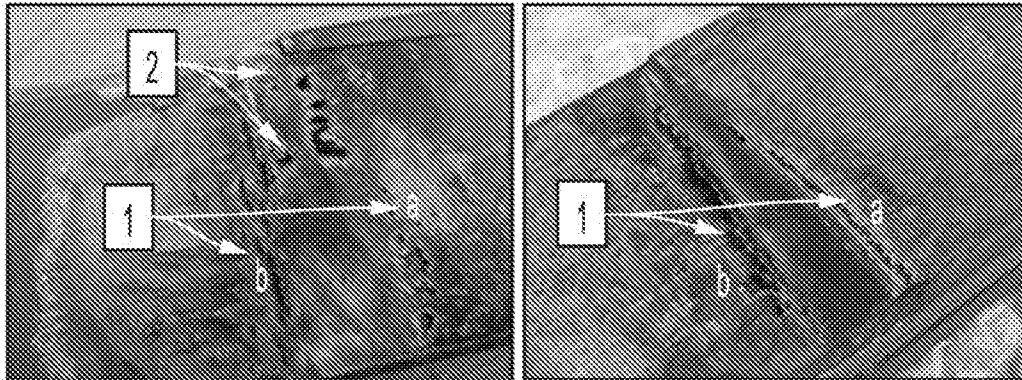

FIG. 12



**Non-conductive Adhesive Joint**

**Conductive Adhesive Joint**

Electrical energy arcs from plate 1 to plate 2 using two paths:

1. From the nearby surface of one plate (a) to the nearby surface of the second plate (b)
2. Through the non-conductive adhesive layer itself

Electrical energy arcs from plate 1 to plate 2 using only one path:

1. From the nearby surface of one plate (a) to the nearby surface of the second plate (b)

**FIG. 13**

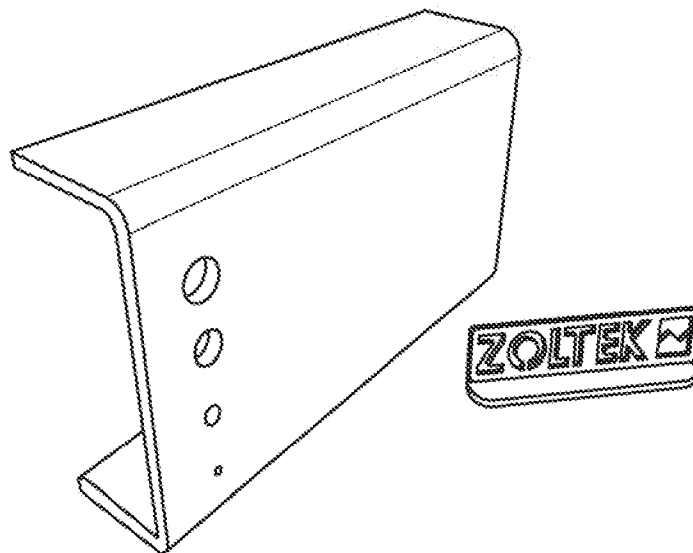

**FIG. 14**

INTERNATIONAL SEARCH REPORT

International application No  
PCT/US2019/024563

A. CLASSIFICATION OF SUBJECT MATTER  
INV. C09J9/02 F03D1/06  
ADD.  
According to International Patent Classification (IPC) or to both national classification and IPC

B. FIELDS SEARCHED  
Minimum documentation searched (classification system followed by classification symbols)  
C09J F03D

Documentation searched other than minimum documentation to the extent that such documents are included in the fields searched

Electronic data base consulted during the international search (name of data base and, where practicable, search terms used)  
EPO-Internal, WPI Data

C. DOCUMENTS CONSIDERED TO BE RELEVANT

Category*	Citation of document, with indication, where appropriate, of the relevant passages	Relevant to claim No.
X	DATABASE WPI Week 201211 Thomson Scientific, London, GB; AN 2012-A38824 XP002792788, & CN 102 277 097 A (IRICO GROUP CO LTD) 14 December 2011 (2011-12-14)	1-4, 6-18, 22-35, 37,39
Y	abstract	19-21, 36,38,40
A		5
X	----- US 2004/254294 A1 (CLULOW JOHN [US] ET AL) 16 December 2004 (2004-12-16)  paragraphs [0022] - [0025] -----  -/--	1,3-10, 22-24, 37,39

Further documents are listed in the continuation of Box C.

See patent family annex.

\* Special categories of cited documents :

- "A" document defining the general state of the art which is not considered to be of particular relevance
- "E" earlier application or patent but published on or after the international filing date
- "L" document which may throw doubts on priority claim(s) or which is cited to establish the publication date of another citation or other special reason (as specified)
- "O" document referring to an oral disclosure, use, exhibition or other means
- "P" document published prior to the international filing date but later than the priority date claimed

- "T" later document published after the international filing date or priority date and not in conflict with the application but cited to understand the principle or theory underlying the invention
- "X" document of particular relevance; the claimed invention cannot be considered novel or cannot be considered to involve an inventive step when the document is taken alone
- "Y" document of particular relevance; the claimed invention cannot be considered to involve an inventive step when the document is combined with one or more other such documents, such combination being obvious to a person skilled in the art
- "&" document member of the same patent family

Date of the actual completion of the international search  10 July 2019	Date of mailing of the international search report  23/07/2019
Name and mailing address of the ISA/ European Patent Office, P.B. 5818 Patentlaan 2 NL - 2280 HV Rijswijk Tel. (+31-70) 340-2040, Fax: (+31-70) 340-3016	Authorized officer  Saunders, Thomas

## INTERNATIONAL SEARCH REPORT

International application No  
PCT/US2019/024563

C(Continuation). DOCUMENTS CONSIDERED TO BE RELEVANT		
Category*	Citation of document, with indication, where appropriate, of the relevant passages	Relevant to claim No.
X	WO 2009/147415 A1 (HEXCEL COMPOSITES LTD [GB]; CAWSE JOHN LESLIE [GB] ET AL.) 10 December 2009 (2009-12-10) example 1 -----	1-9, 22-24
X	WO 2016/048885 A1 (CYTEC IND INC [US]) 31 March 2016 (2016-03-31) examples 1, 2 -----	1-8, 22-24
Y	EP 2 264 310 A2 (GEN ELECTRIC [US]) 22 December 2010 (2010-12-22) paragraphs [0008], [0015]; claim 1 -----	19-21, 36,38,40
A	WO 2009/079216 A1 (3M INNOVATIVE PROPERTIES CO [US]) 25 June 2009 (2009-06-25) claim 1 -----	1-18, 22-40
A	WO 2004/059663 A1 (SHOWA DENKO KK [JP]; MORITA TOSHIO [JP] ET AL.) 15 July 2004 (2004-07-15) claim 18; example 1 -----	1-40

## INTERNATIONAL SEARCH REPORT

Information on patent family members

International application No

PCT/US2019/024563

Patent document cited in search report	Publication date	Patent family member(s)	Publication date
CN 102277097	A	14-12-2011	NONE
US 2004254294	A1	16-12-2004	NONE
WO 2009147415	A1	10-12-2009	EP 2285879 A1 23-02-2011 ES 2639864 T3 30-10-2017 GB 2464085 A 07-04-2010 JP 5279053 B2 04-09-2013 JP 2011522920 A 04-08-2011 US 2011163275 A1 07-07-2011 US 2015060738 A1 05-03-2015 WO 2009147415 A1 10-12-2009
WO 2016048885	A1	31-03-2016	AU 2015321585 A1 16-03-2017 BR 112017005619 A2 23-01-2018 CA 2961910 A1 31-03-2016 CN 107107537 A 29-08-2017 EP 3197674 A1 02-08-2017 JP 2017535447 A 30-11-2017 RU 2017113772 A 24-10-2018 TW 201615390 A 01-05-2016 US 2016082691 A1 24-03-2016 US 2019143633 A1 16-05-2019 WO 2016048885 A1 31-03-2016
EP 2264310	A2	22-12-2010	CN 101900088 A 01-12-2010 DK 2264310 T3 18-07-2016 EP 2264310 A2 22-12-2010 US 2010132884 A1 03-06-2010
WO 2009079216	A1	25-06-2009	AT 524532 T 15-09-2011 CN 101903485 A 01-12-2010 EP 2231803 A1 29-09-2010 JP 2011506751 A 03-03-2011 KR 20100095018 A 27-08-2010 KR 20150095943 A 21-08-2015 TW 200946633 A 16-11-2009 US 2009155597 A1 18-06-2009 WO 2009079216 A1 25-06-2009
WO 2004059663	A1	15-07-2004	AT 395705 T 15-05-2008 AU 2003292554 A1 22-07-2004 CN 1732538 A 08-02-2006 EP 1588385 A1 26-10-2005 KR 20050090419 A 13-09-2005 US 2006035081 A1 16-02-2006 WO 2004059663 A1 15-07-2004