



US00D702598S

(12) **United States Design Patent**
Wada

(10) **Patent No.:** **US D702,598 S**

(45) **Date of Patent:** **** Apr. 15, 2014**

(54) **AUTOMOBILE AND/OR REPLICA THEREOF**

(71) Applicant: **Honda Motor Co., Ltd.**, Tokyo (JP)

(72) Inventor: **Riku Wada**, Wako (JP)

(73) Assignee: **Honda Motor Co., Ltd.**, Tokyo (JP)

(**) Term: **14 Years**

(21) Appl. No.: **29/437,676**

(22) Filed: **Nov. 20, 2012**

(30) **Foreign Application Priority Data**

May 25, 2012 (JP) 2012012382

(51) **LOC (10) Cl.** **12-08**

(52) **U.S. Cl.**
USPC **D12/92**

(58) **Field of Classification Search**
USPC D12/86, 90-92; D21/424, 433, 434;
296/181.1, 181.5

See application file for complete search history.

(56) **References Cited**

U.S. PATENT DOCUMENTS

D599,706 S * 9/2009 Tanaka et al. D12/92
D626,457 S * 11/2010 Lian et al. D12/92

D637,521 S * 5/2011 Kim D12/92
D637,944 S * 5/2011 Lee D12/92
D641,666 S * 7/2011 Yi D12/92
D647,823 S * 11/2011 Okumoto et al. D12/92
D667,756 S * 9/2012 Asakura et al. D12/92
D691,517 S * 10/2013 Kwon et al. D12/92

* cited by examiner

Primary Examiner — Melody Brown

(74) *Attorney, Agent, or Firm* — Plumsea Law Group, LLC

(57) **CLAIM**

The ornamental design for, an automobile and/or replica thereof, as shown and described.

DESCRIPTION

FIG. 1 is a front and right side perspective view of an automobile and/or replica thereof, showing our new design; FIG. 2 is a rear and right side perspective view thereof; FIG. 3 is a front elevation view thereof; FIG. 4 is a rear elevation view thereof; FIG. 5 is a top plan view thereof; FIG. 6 is a right side elevation view thereof; and, FIG. 7 is a left side elevation view thereof. The broken lines are for illustrative purposes only and form no part of the claimed design.

1 Claim, 7 Drawing Sheets

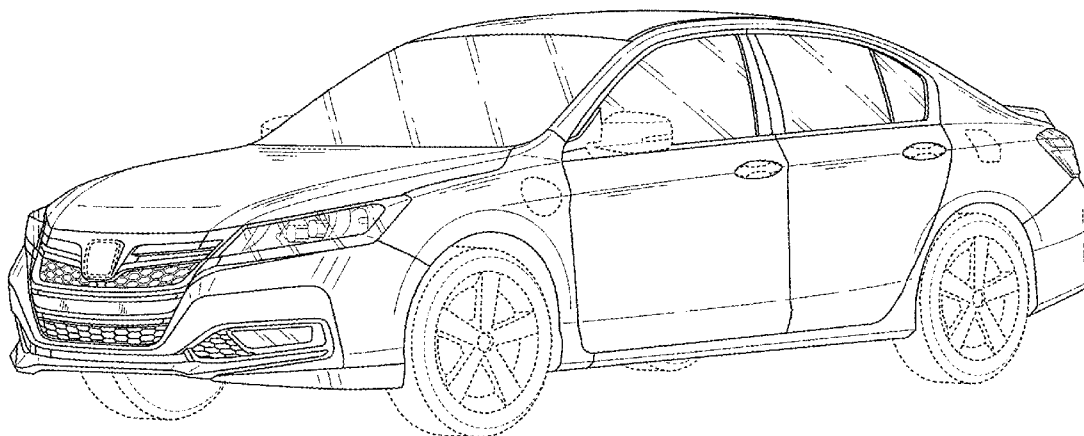

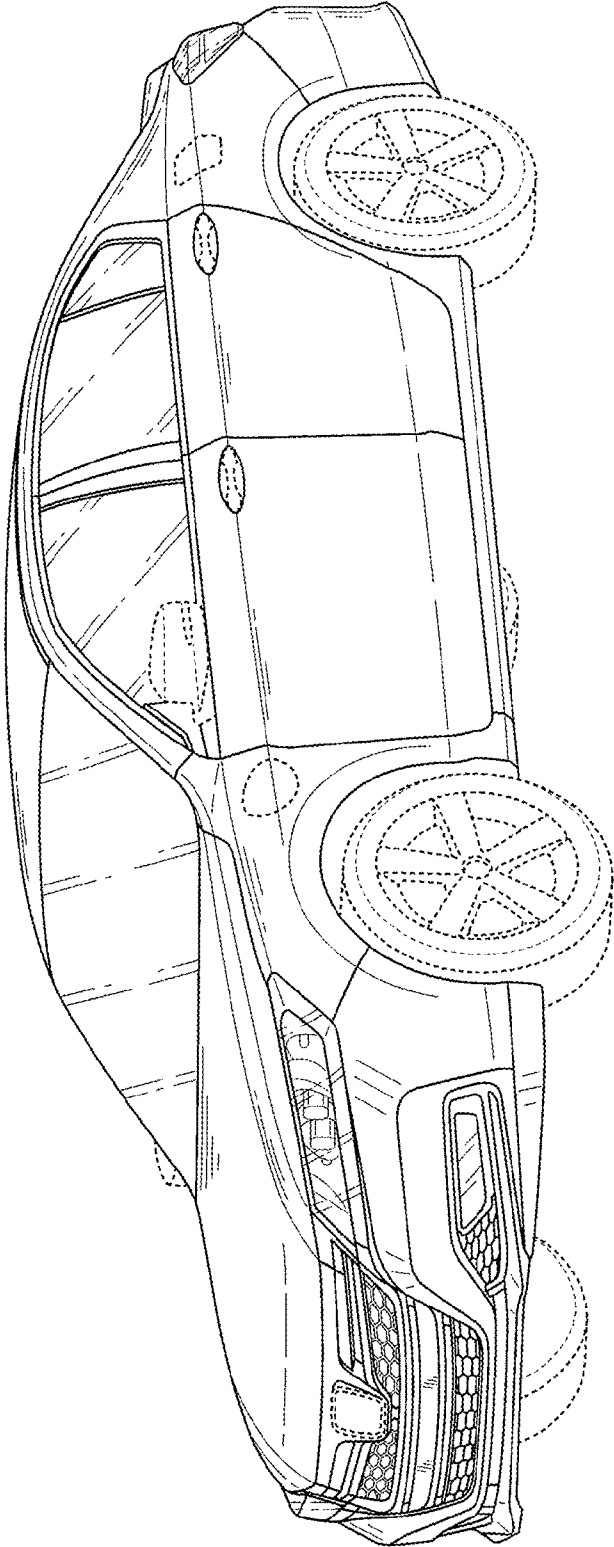
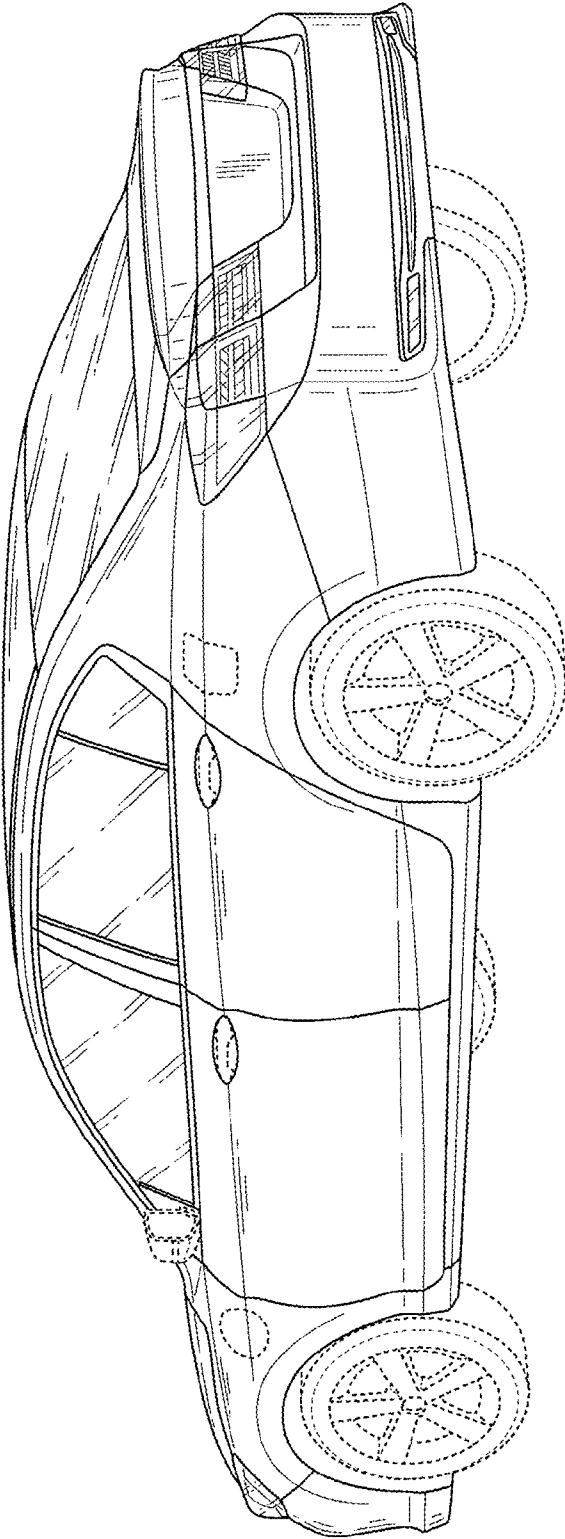

FIG. 1

FIG. 2



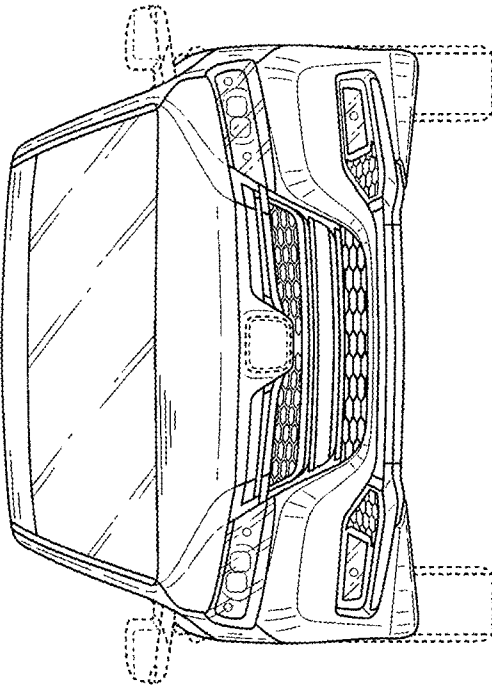

FIG. 3

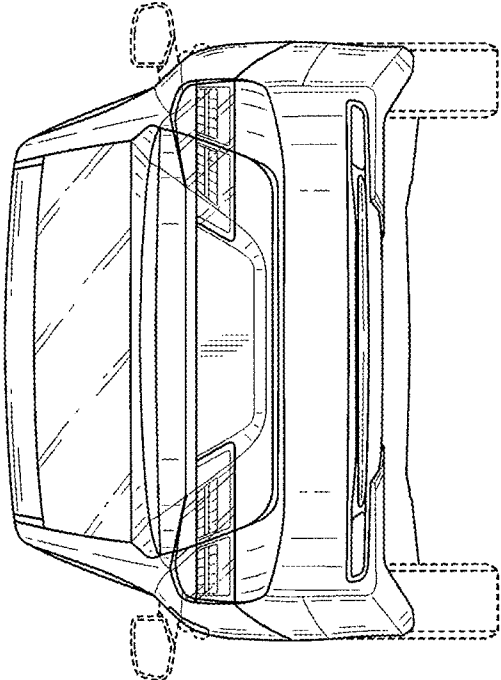
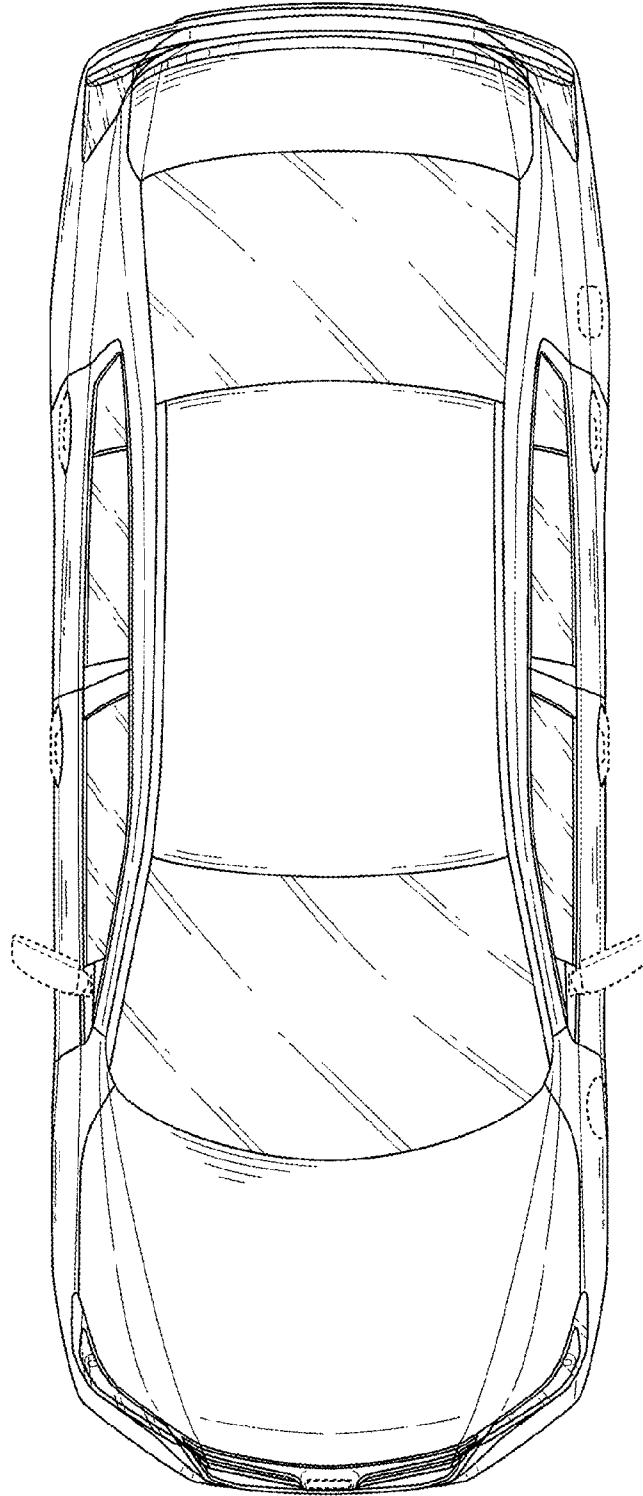

FIG. 4

FIG. 5



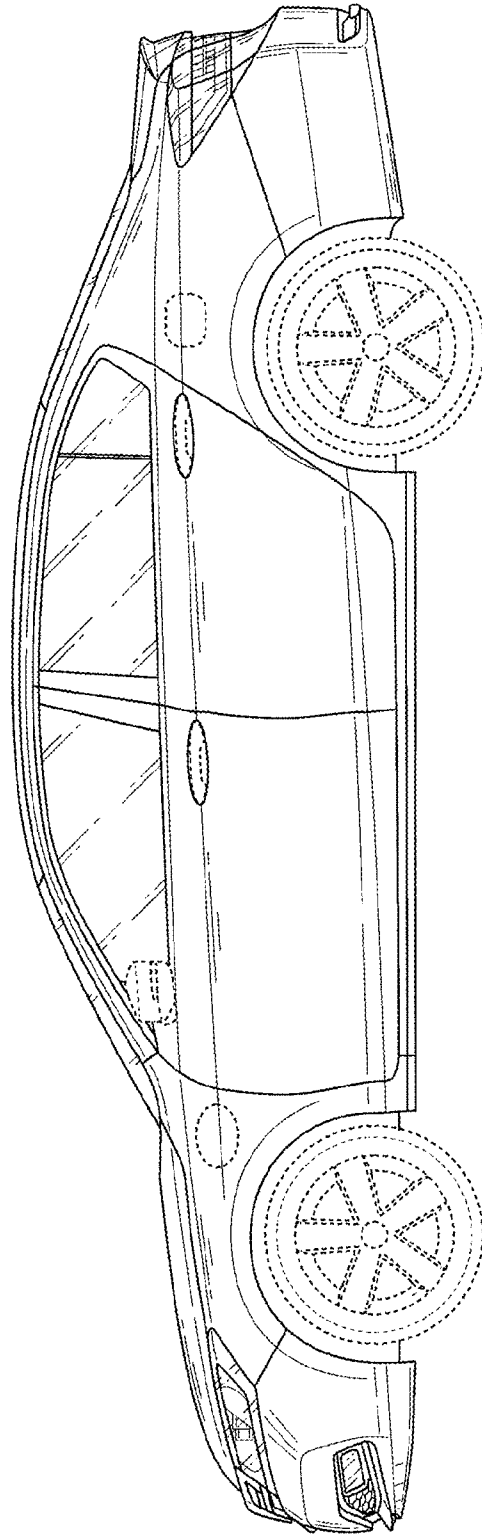

FIG. 6

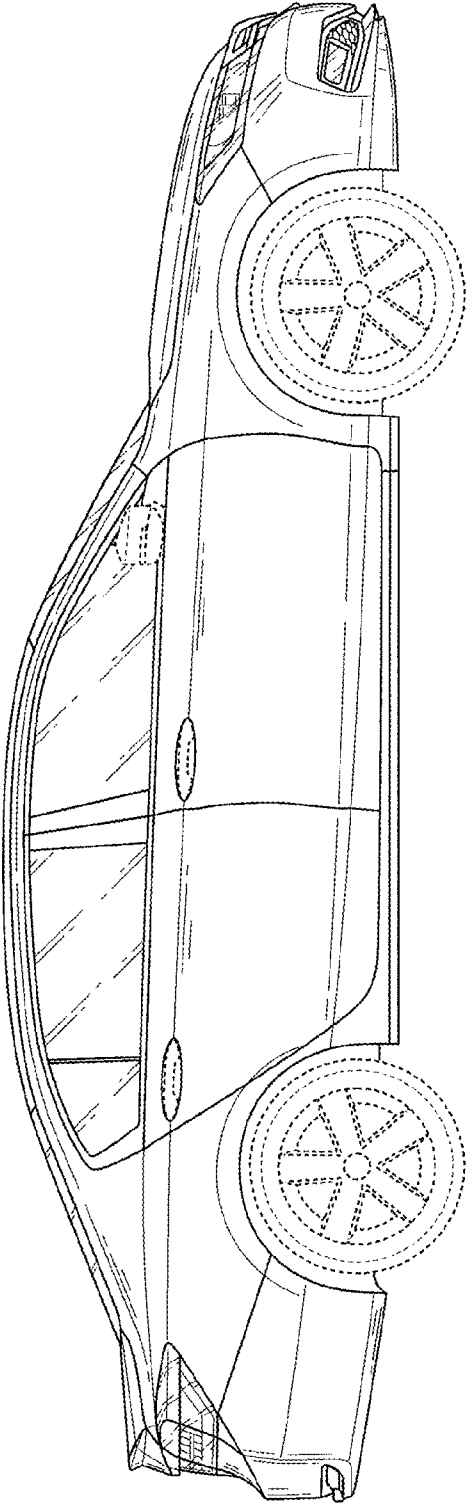

FIG. 7