



US 20210062464A1

(19) **United States**

(12) **Patent Application Publication**

**Pino, JR. et al.**

(10) **Pub. No.: US 2021/0062464 A1**

(43) **Pub. Date: Mar. 4, 2021**

(54) **ROADWAY ACCESS HOLE DRILL AND A METHOD OF MICROTRENCHING USING THE DRILL TO OPEN AN ACCESS HOLE IN THE ROADWAY**

(71) Applicant: **CCIP LLC**, New York, NY (US)

(72) Inventors: **Angelo J. Pino, JR.**, New York, NY (US); **Daniel Urban**, Austin, TX (US)

(21) Appl. No.: **16/905,549**

(22) Filed: **Jun. 18, 2020**

**Related U.S. Application Data**

(63) Continuation of application No. 16/812,777, filed on Mar. 9, 2020, now Pat. No. 10,808,379.

(60) Provisional application No. 62/892,698, filed on Aug. 28, 2019, provisional application No. 62/978,953, filed on Feb. 20, 2020.

**Publication Classification**

(51) **Int. Cl.**  
*E02F 5/08* (2006.01)  
*E01C 11/00* (2006.01)  
*G02B 6/50* (2006.01)  
*E02F 5/12* (2006.01)

(52) **U.S. Cl.**  
 CPC ..... *E02F 5/08* (2013.01); *E02F 5/12* (2013.01); *G02B 6/504* (2013.01); *E01C 11/005* (2013.01)

(57) **ABSTRACT**

A method of cutting a microtrench in which the buried utility is exposed by opening an access hole in a roadway above the buried utility using a roadway access hole drill that rotates and vibrates the drill bit. A roadway access hole drill having a down-the-hole jack-hammer drill bit and a motor to rotate the down-the-hole jack-hammer drill.

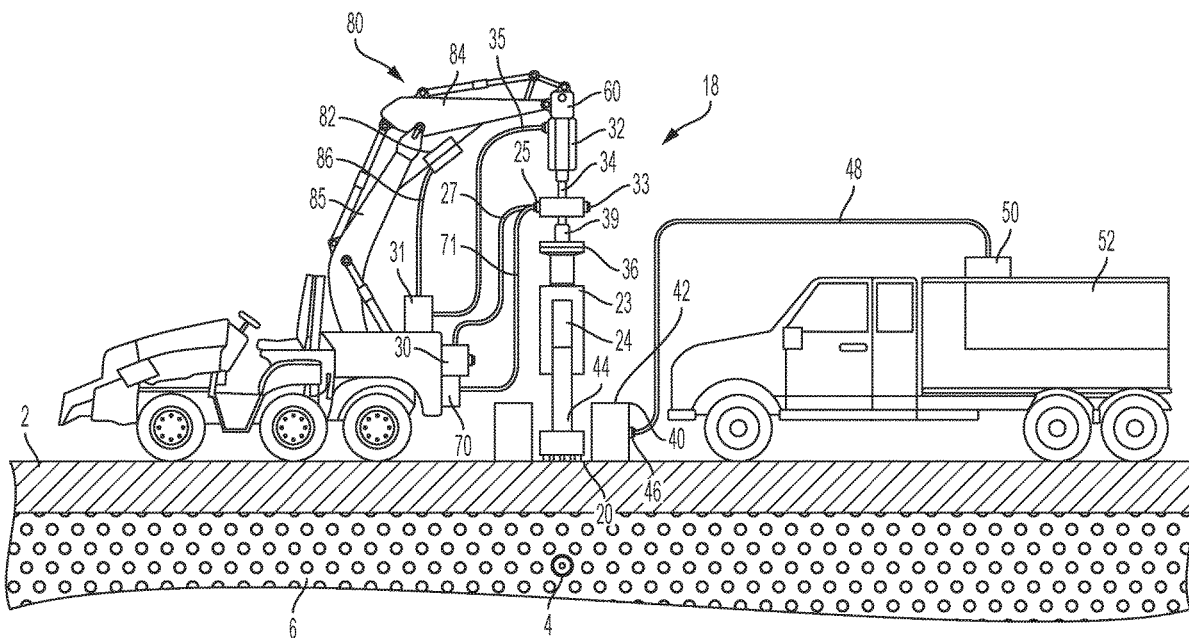

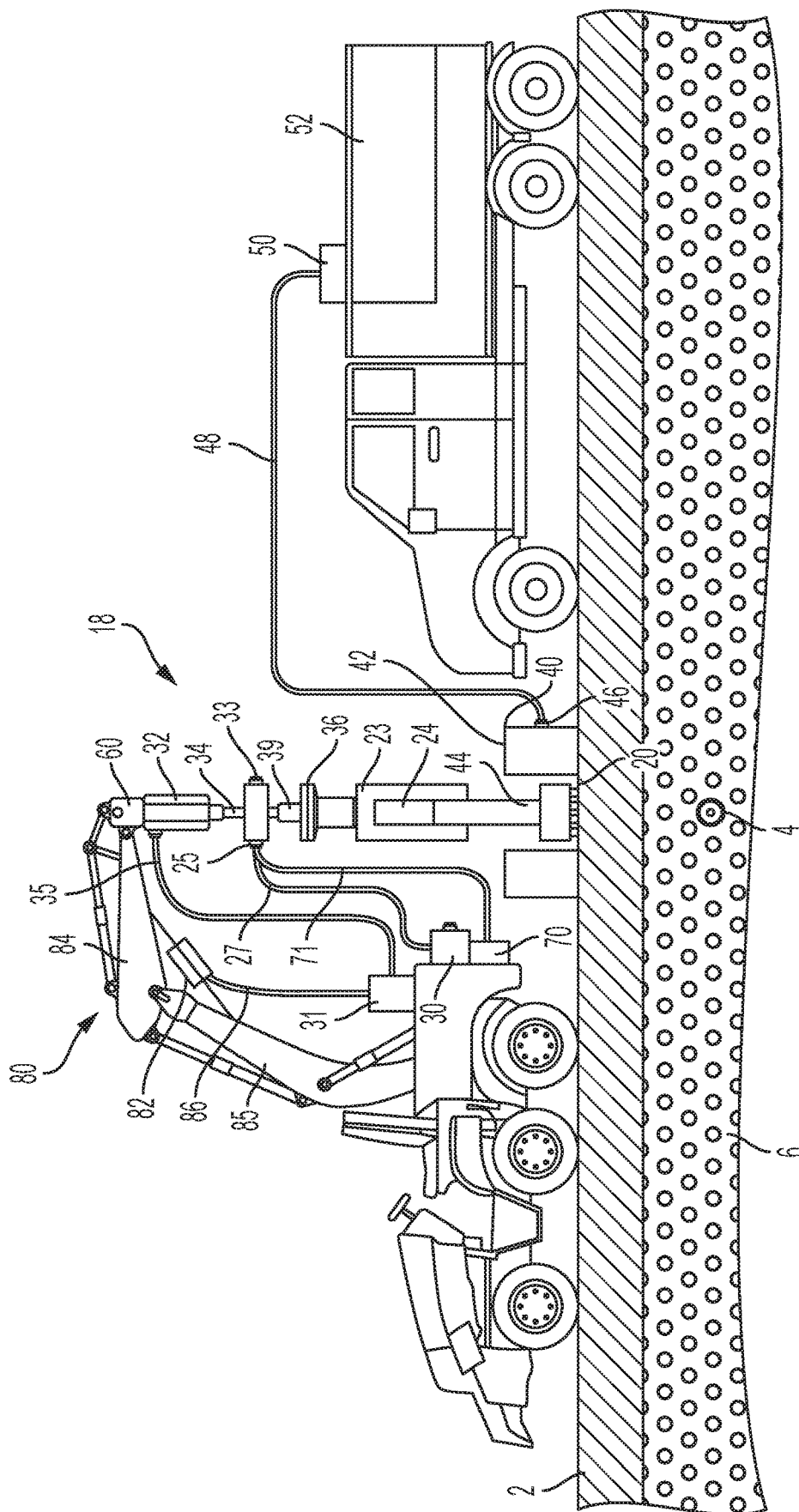

FIG. 1

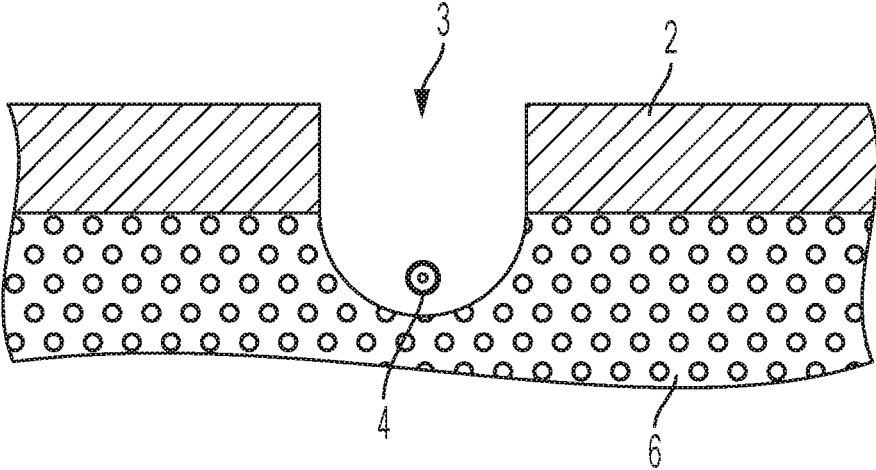

FIG. 2

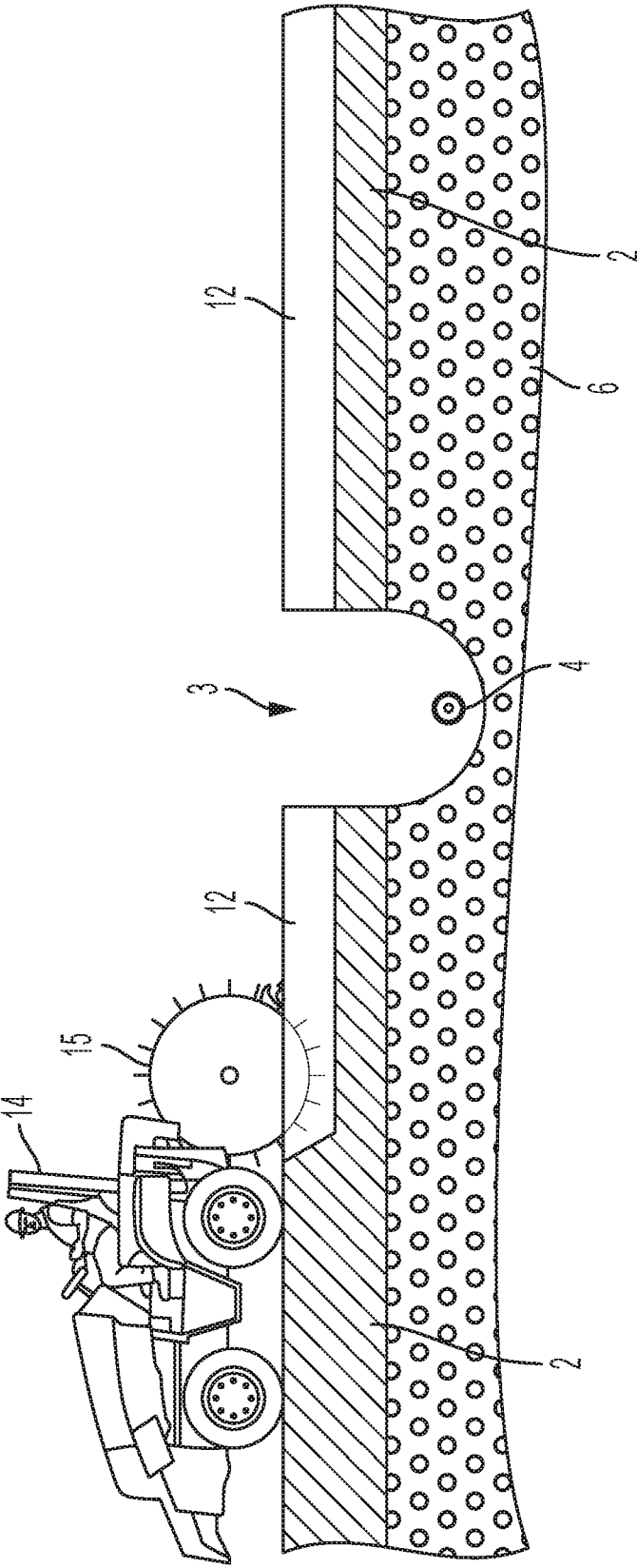

FIG. 3

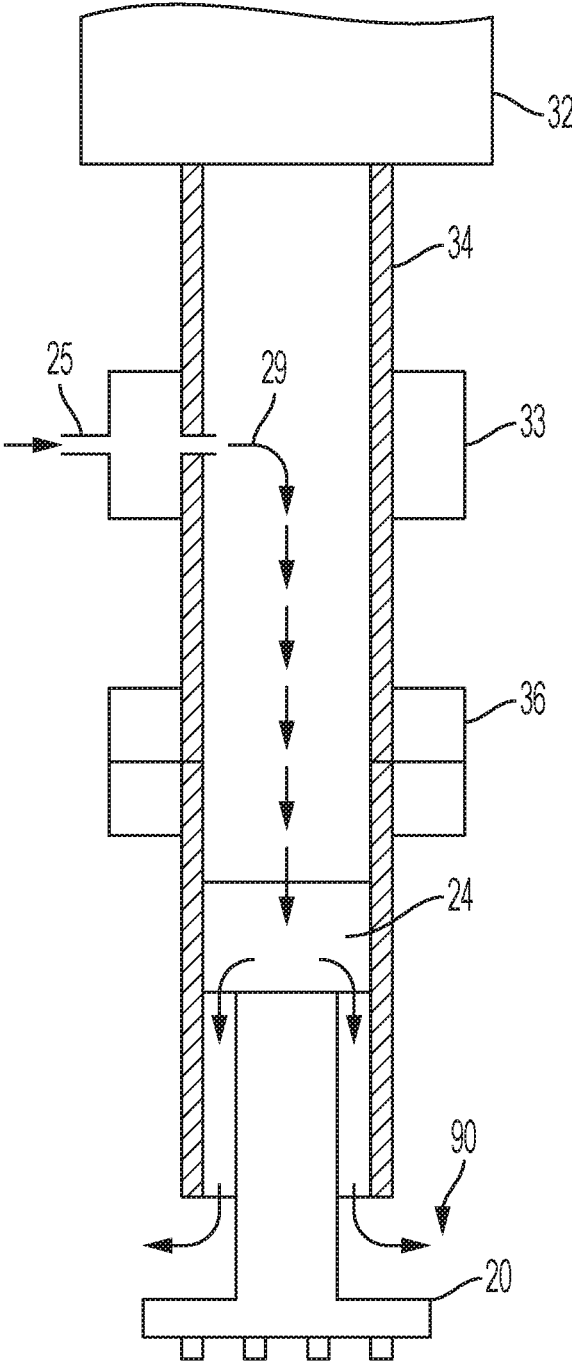

FIG. 4

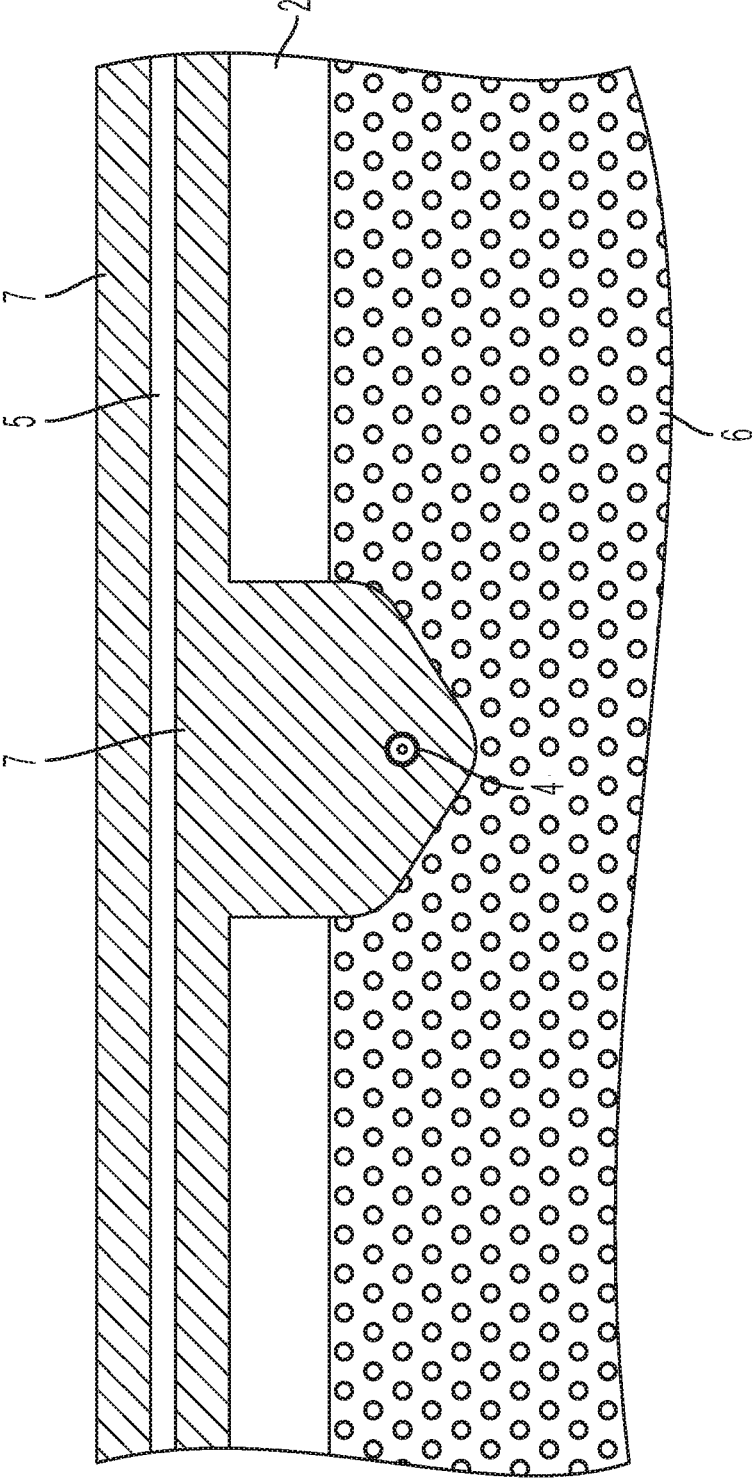

FIG. 5

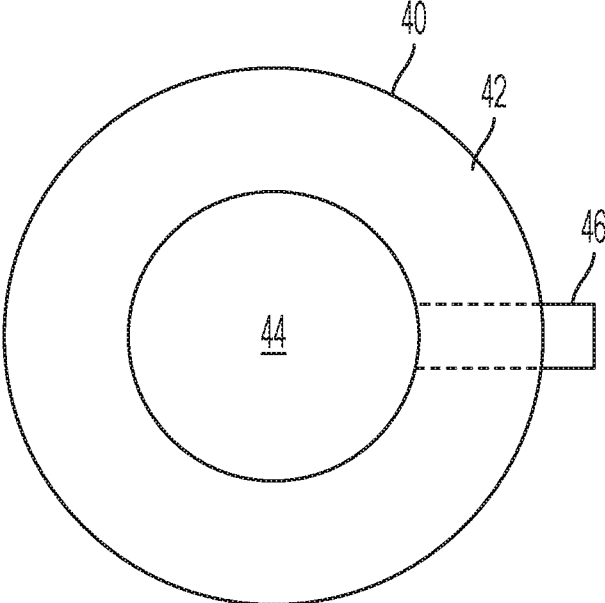

FIG. 6

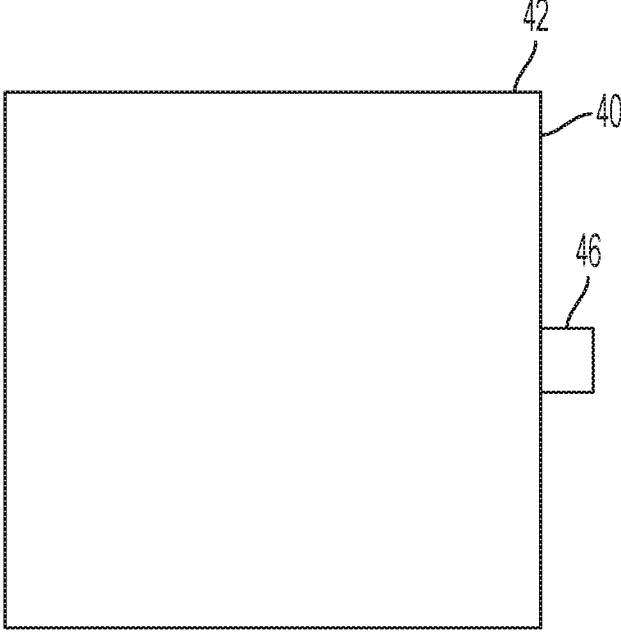

FIG. 7

**ROADWAY ACCESS HOLE DRILL AND A  
METHOD OF MICROTRENCHING USING  
THE DRILL TO OPEN AN ACCESS HOLE IN  
THE ROADWAY**

FIELD OF THE INVENTION

**[0001]** The invention generally relates to a roadway access hole drill and a method for creating a microtrench in a roadway and burying an optical fiber and/or innerduct/microduct below the roadway surface. The roadway access hole drill vibrates and rotates a drill bit to quickly cut an access hole in a roadway above a buried utility.

BACKGROUND OF THE INVENTION

**[0002]** Installing new optical fiber networks to a location is expensive and time consuming. There is a great need for faster and less expensive installation of optical fiber.

**[0003]** During installation of the optical fiber, a microtrench is cut in a roadway, the optical fiber and/or innerduct/microduct is laid in the microtrench and then a fill and sealant are applied over the optical fiber and/or innerduct/microduct to protect them from the environment. Methods of microtrenching that can be utilized in the present invention include the method described in my previous U.S. patent publication Nos. 20190226603, 20190086002, 20180292027, 20180156357, and 20180106015, the complete disclosures of which are incorporated in their entirety herein by reference.

**[0004]** Before cutting a microtrench in a roadway, the city must be notified. The city personnel will locate and mark buried utilities on the roadway. When a microtrench must cross a buried utility, the buried utility must first be exposed, which requires cutting an access hole through the roadway and then removing the dirt below the roadway through the roadway access hole. Currently, core saws, concrete saws, core drills and jack hammers are used to break through roadway, which takes about 25-30 minutes or more. The buried utility can be damaged by the current methods of opening the roadway. There is a need for a faster and safer method to open the roadway to expose the buried utility.

SUMMARY OF THE INVENTION

**[0005]** The present invention utilizes a roadway access hole drill comprising a down-the-hole jack-hammer drill (hereinafter DTH hammer), a motor to rotate the DTH hammer, and a debris containment collar to cover the drill bit in a novel and new way to provide an access hole in a roadway above a buried utility. The novel use of the DTH hammer provides a far faster and safer method to expose the buried utility. Using the present invention, the roadway can now be opened far faster, in about 5 minutes or less, compared to 25-30 minutes or more for conventional roadway cutting methods.

**[0006]** Objectives of the invention can be obtained by a method of installing optical fiber, innerduct or microduct under a roadway comprising:

**[0007]** providing a roadway access drill comprising a down-the-hole hammer drill having a drill bit and a jack-hammer that vibrates the drill bit, and a motor attached to the down-the-hole hammer drill that rotates the drill bit;

**[0008]** placing a debris containment collar on a roadway surface over a buried utility, the debris containment

collar having a debris containment collar body defining a hollow chamber sized to accept the drill bit;

**[0009]** inserting the drill bit into the hollow chamber of the debris containment collar so that the debris containment collar body surrounds the drill bit;

**[0010]** activating the motor and jack-hammer to provide a rotating and vibrating drill bit;

**[0011]** drilling an access hole in the roadway by lowering the rotating and vibrating drill bit into the roadway, wherein the debris containment collar prevents debris formed during the drilling from flying away;

**[0012]** removing dirt below the roadway through the access hole to expose the buried utility;

**[0013]** cutting a microtrench in the roadway using a microtrencher so that the microtrench crosses the buried utility and does not damage the buried utility;

**[0014]** laying the optical fiber, innerduct or microduct in the microtrench; and

**[0015]** filling the microtrench with a fill material to cover and protect the optical fiber, innerduct or microduct.

**[0016]** Objectives of the invention can further be obtained by a method of cutting an access hole in a roadway comprising:

**[0017]** providing a roadway access drill comprising a down-the-hole hammer drill having a drill bit and a jack-hammer that vibrates the drill bit, and a motor attached to the down-the-hole hammer drill that rotates the drill bit;

**[0018]** placing a debris containment collar on a roadway surface over a buried utility, the debris containment collar having a debris containment collar body defining a hollow chamber sized to accept the drill bit;

**[0019]** inserting the drill bit into the hollow chamber of the debris containment collar so that the debris containment collar body surrounds the drill bit;

**[0020]** activating the motor and jack-hammer to provide a rotating and vibrating drill bit; and

**[0021]** drilling an access hole in the roadway by lowering the rotating and vibrating drill bit into the roadway, wherein the debris containment collar prevents debris formed during the drilling from flying away.

**[0022]** Objectives of the invention can also be obtained by a roadway access drill comprising:

**[0023]** a down-the-hole hammer drill having a drill bit and a jack-hammer that vibrates the drill bit;

**[0024]** a motor attached to the down-the-hole hammer drill that rotates the drill bit; and

**[0025]** a debris containment collar having a debris containment collar body defining a hollow chamber sized to accept the drill bit and configured to contain debris.

BRIEF DESCRIPTION OF THE DRAWINGS

**[0026]** FIG. 1 illustrates a roadway access hole drill located over the roadway above a buried utility.

**[0027]** FIG. 2 illustrates hole in the roadway cut by the roadway access hole drill to expose the buried utility.

**[0028]** FIG. 3 illustrates a microtrencher cutting a microtrench in the roadway that crosses the exposed previously buried utility.

**[0029]** FIG. 4 illustrates air/water flow through the roadway access hole drill.

**[0030]** FIG. 5 illustrates an optical fiber sealed in the microtrench by a fill.



**[0031]** FIG. 6 illustrates a top view of a debris containment collar.

**[0032]** FIG. 7 illustrates a side view of a debris containment collar.

#### DETAILED DESCRIPTION OF THE INVENTION

**[0033]** The invention will be explained by reference to the attached non-limiting Figs. DTH hammers are used to cut through rock down in a hole core. The following description is from Center Rock Products, www.centerrock.com, "Center Rock offers one of the most complete lines of down the hole drills and downhole bits ranging from 3.5"-36" (89 mm-914 mm) which are designed for peak performance in all rock drilling applications including but not limited to; foundation & geotechnical drilling, blasthole drilling in quarries & mines, waterwell & geothermal boreholes, oil & gas underbalanced drilling, horizontal directional drilling, and utility transmission & distribution rock sockets." Suitable DTH hammers for use in the present invention include those commercially available from Center Rock Products, Everdigm, Sandvik, and others, DTH hammers require large and tall machinery to hold the long pipe extensions in order to drill a deep hole. Furthermore, the DTH hammer is usually contained within and supported by the pipe during cutting the bore hole.

**[0034]** The novel use of the DTH hammer **23** in the present invention does not require the long pipe extensions, the DTH hammer **23** does not have to be contained within a pipe, and a novel debris containment collar is utilized in the present invention. Preferably, the present roadway access hole drill **18** utilizes a DTH hammer **23** as shown in the attached Figs. in which the DTH hammer **23** moves up and down a length required to cut through a roadway, such as less than 10 feet, preferably less than 5 feet. The roadway access hole drill **18** can include an attachment **60** for mounting to a backhoe, or other common construction device. The roadway access drill **18** preferably is configured to be driven by conventional construction power devices, such as hydraulic pressure, compressed air, electric, gas engines or diesel engines.

**[0035]** The DTH hammer **23** includes a drill bit **20** and a jack-hammer **24** for aggressively vibrating the drill bit **20**. The jack-hammer **24** can be driven by pressurized fluid (hydraulic fluid) or compressed air. Preferably the jack-hammer **24** is driven by a mixture of compressed air and water so that when the water exits the DTH hammer **23** the water reduces the formation of airborne dust. The compressed air or hydraulic fluid (shown at **29**) enters and flows through the DTH hammer **23** and then preferably exits (shown at **90**) at the bottom near the drill bit **20**. Any suitable source of compressed air or hydraulic fluid can be utilized. Instead of air, the jackhammer can be driven by electric, hydraulic, gas, or other, as desired. An air compressor **30** can be used as the source of compressed air to power or activate the jack-hammer **24**. The DTH hammer **23** can have a diameter of about 6 to about 48 inches, preferably about 10 to about 24 inches. An example of suitable air pressure is 100 psi to 900 psi, preferably about 300 to 600 psi. The flow can be from 100 to 2000 cfm, preferably about 300 to about 1000 cfm. The example roadway access drill **18** shown in FIG. 1 was tested and cut a hole through a concrete roadway **2** in less than 5 minutes using about 500 psi in pressure and about 750 cfm in flow.

**[0036]** The roadway access drill **18** includes a motor **32** configured to rotate the drill bit **20**, and usually the entire DTH hammer **23**. The motor **32** can be powered by any desired source, such as electric, gas, diesel, or hydraulic. Preferably, the motor **32** is driven by a source of hydraulic pressure **31**. Bore hole motors for rotating a DTH hammer **23** for making a bore hole are well-known and any suitable conventional bore hole motor can be utilized as the motor **32**. Sources of hydraulic pressure are now well known and any desired source of hydraulic pressure **31** can be utilized, such as those used on backhoes and other equipment utilizing a hydraulic cylinder **82**. A hydraulic fluid hose **35** can connect the motor **32** to the source of hydraulic pressure **31**.

**[0037]** The motor **32** can be connected to the DTH hammer **23** by a drive connector **34**. A collar connector **36** can be utilized to removably connect the DTH hammer **23** to the drive connector **34**. The drive connector **34** can be a pipe having a hollow chamber **39**. A swivel connector **33** can be used to supply compressed air and/or pressurized fluid to the hollow chamber **39**. Swivel connectors **33** are now well known and any suitable swivel connector **33** can be utilized in the present invention, such as swivel connectors used in the oil and water well boring rigs. The chamber **39** connects the flow of compressed air and/or pressurized fluid from the swivel connector **33** to the DTH hammer **23**. The compressed air and/or pressurized fluid powers flow into and powers or activates the jack-hammer **24** and then can flow out of the DTH hammer **23** near the drill bit **20**. The swivel connector **33** encircles the drive connector **34** and is configured to allow the drive connector **34** to rotate within the swivel connector **33**. The swivel connector **33** includes a compressed air connection **25** that can be used to connect to a compressed air hose **27**, which can supply compressed air, a pressurized fluid, and preferably a mixture of compressed air and water to the swivel connector **33**. The collar connector **36** can be a chuck, threaded connector, or any suitable device for removably connecting two shafts or pipes together, such as those used in oil or water drilling rigs.

**[0038]** A source of pressurized water **70** can be connected to a pressurized water hose **71** connected to the compressed air connection **25** to supply pressurized water along with the compressed air to the DTH hammer **23**. The water exiting the DTH hammer **23** can reduce the airborne dust created during drilling the access hole. The water can be vacuumed up along with the debris using the debris containment collar **40**. Sources of pressurized water **70** are now well known and any suitable source can be utilized, such as power washer water pressurizers.

**[0039]** Any suitable lifting device can be connected to the lifting attachment **60** and used to lift and lower the roadway access hole drill **18**. A preferred example of a lifting device is a backhoe **80** having a boom **85** connected to an arm **84**, a hydraulic cylinder **82** for moving the arm **84** in relation to the boom **85**, the arm **84** is connected to the lifting attachment **60**, and the hydraulic cylinder **82** is connected to the source of pressurized hydraulic fluid **31** by hydraulic cylinder hose **86**. The engine of the backhoe **80** can be used to power a pump to pressurize the source of pressurized hydraulic fluid **31** in a conventional manner. Backhoes **80** are well-known and the hydraulic cylinder **82** can be operated in a conventional manner to lift and lower the arm **84**.

**[0040]** The debris containment collar **40** that sits on a surface of the roadway **2** can take the place of the pipe conventionally used in bore holes, so that the drill bit **20** sits

within the debris containment collar **40**. The debris containment collar **40** is placed on the roadway **2** over the buried utility **4** to be exposed. The debris containment collar **40** comprises a debris containment collar body **42** defining a hollow chamber **44** that is sized to fit around the drill bit **20**. A debris containment collar vacuum attachment **46** for attaching to a vacuum hose **48** attached to a source of vacuum **50**. The debris containment collar **40** is configured to provide a vacuum to the hollow chamber **44** during use. During use, the debris containment collar **40** rests on the roadway **2** surface and the debris, such as dust, chips, particles, etc., and water if present are vacuumed away through the vacuum hose **48** and into a vacuum storage container **52**. The debris containment collar **40** can also be used to align the drill bit **20**. The vacuum hose **48** can be any size as desired, such as from 4 to 12 inches in diameter. Sources of vacuum **50** are now well known and any suitable vacuum source can be utilized, such as those made by SCAG Giant Vac., DR Power, Vermeer, and Billy Goat.

[0041] The Figs. show how the DTH hammer **18** can be used to cut an access hole **3** in the roadway **2** in a far faster and safer way than previous methods. In FIG. 1, the debris containment collar **40** is placed on the roadway surface over the buried utility. The drill bit **20** is inserted into the chamber **44**. The motor **32** and jack-hammer **24** are activated to both rotate and vibrate the drill bit **20**. The drill bit **20** is lowered to cut an access hole **3** in the roadway **2** as shown in FIG. 2. The dirt **6** below the roadway is then removed to expose the buried utility **4**.

[0042] As shown in FIG. 3, once the buried utility **4** is exposed, a microtrencher **14** is used to cut a microtrench **12** in the roadway so that the microtrench **12** crosses the buried utility **4** without damaging the buried utility **4**. As shown in FIG. 5, the optical fiber, innerduct, or microduct **5** can be laid in the microtrench **12**, and the a fill **7** can be applied to cover the hole **3** and fill the microtrench **12** to cover and protect the optical fiber, innerduct, or microduct **5**.

[0043] Any suitable microtrencher **14** can be utilized in the present invention. Non-limiting examples of suitable micro trenchers include those made and sold by Ditch Witch, Vermeer, and Marais. A Vermeer RTX 1250 tractor can be used as the motorized vehicle for the microtrencher **14**. A microtrencher **14** has is a “small rock wheel” specially designed for work in rural or urban areas. The microtrencher **14** is fitted with a microtrencher blade **15** that cuts a microtrench **11** with smaller dimensions than can be achieved with conventional trench digging equipment. Microtrench **11** widths usually range from about 6 mm to 130 mm (¼ to 5 inches) with a depth of 750 mm (about 30 inches) or less. Other widths and depths can be used as desired.

[0044] With a microtrencher **14**, the structure of the road, sidewalk, driveway, or path is maintained and there is no associated damage to the road. Owing to the reduced microtrench **11** size, the volume of waste material (spoil **12**) excavated is also reduced. Microtrenchers **14** are used to minimize traffic or pedestrian disturbance during cable laying. The microtrencher **14** can work on sidewalks or in narrow streets of cities, and can cut harder ground than a chain trencher, including cutting through for example but not limited to solid stone, concrete, and asphalt.

## TERMS

[0045]	2 Roadway
[0046]	3 Access hole
[0047]	4 Buried utility
[0048]	5 Optical fiber, innerduct, microduct
[0049]	6 Dirt
[0050]	7 Fill
[0051]	12 Microtrench
[0052]	14 Microtrencher
[0053]	15 Microtrencher blade
[0054]	18 Roadway access hole drill
[0055]	20 Drill bit
[0056]	23 DTH hammer
[0057]	24 Jack-hammer
[0058]	25 Compressed air connection
[0059]	27 Compressed air hose
[0060]	29 Flow of compressed air/water
[0061]	30 Air compressor
[0062]	31 Source of pressurized hydraulic fluid
[0063]	32 Motor
[0064]	33 Swivel connector
[0065]	34 Drive connector
[0066]	35 Hydraulic hose
[0067]	36 Collar connector
[0068]	39 Hollow chamber
[0069]	40 Debris containment collar
[0070]	42 Debris containment collar body
[0071]	44 Hollow chamber
[0072]	46 Debris containment collar vacuum attachment
[0073]	48 Vacuum hose
[0074]	50 Source of vacuum
[0075]	52 Vacuum storage container
[0076]	60 Lifting attachment
[0077]	70 Source of water
[0078]	71 Pressurized water hose
[0079]	80 Backhoe
[0080]	84 Arm
[0081]	85 Boom
[0082]	82 Hydraulic cylinder
[0083]	86 Hydraulic cylinder hose
[0084]	90 Exiting air/water

[0085] It is to be understood that the foregoing illustrative embodiments have been provided merely for the purpose of explanation and are in no way to be construed as limiting of the invention. Words used herein are words of description and illustration, rather than words of limitation. In addition, the advantages and objectives described herein may not be realized by each and every embodiment practicing the present invention. Further, although the invention has been described herein with reference to particular structure, steps and/or embodiments, the invention is not intended to be limited to the particulars disclosed herein. Rather, the invention extends to all functionally equivalent structures, processes and uses, such as are within the scope of the appended claims. Those skilled in the art, having the benefit of the teachings of this specification, may affect numerous modifications thereto and changes may be made without departing from the scope and spirit of the invention. While the invention has been described to provide an access hole over a buried utility, the invention can be utilized wherever an access hole in the roadway is required.

1. A method of cutting an access hole in a roadway comprising:

providing a roadway access drill comprising a down-the-hole hammer drill having a drill bit and a jack-hammer that vibrates the drill bit, and a motor attached to the down-the-hole hammer drill that rotates the drill bit;

placing a debris containment collar on a roadway surface over a buried utility, the debris containment collar having a debris containment collar body defining a hollow chamber sized to accept the drill bit;

inserting the drill bit into the hollow chamber of the debris containment collar so that the debris containment collar body surrounds the drill bit;

activating the motor and jack-hammer to provide a rotating and vibrating drill bit; and

drilling an access hole in the roadway by lowering the rotating and vibrating drill bit into the roadway, wherein the debris containment collar prevents debris formed during the drilling from flying away.

2. The method according to claim 1, further providing a source vacuum to the hollow chamber of the debris containment collar and vacuuming debris from the access hole during drilling.

3. The method according to claim 1, further comprising powering the jack-hammer with compressed air from an air compressor.

4. The method according to claim 1, further comprising powering the motor with pressurized hydraulic fluid.

5. The method according to claim 1, further comprising powering the jack-hammer with compressed air and pres-

surized water, wherein water leaving the jack-hammer suppresses the formation of airborne dust during cutting of the access hole.

6. The method according to claim 1, further comprising attaching the roadway access hole drill to a backhoe, and using the backhoe to lift and lower the roadway access hole drill.

7. The method according to claim 6, further comprising attaching the motor to a source of pressurized hydraulic fluid present on the backhoe.

8. A roadway access drill comprising:

a down-the-hole hammer drill having a drill bit and a jack-hammer that vibrates the drill bit;

a motor attached to the down-the-hole hammer drill that rotates the drill bit; and

a debris containment collar having a debris containment collar body defining a hollow chamber sized to accept the drill bit and configured to contain debris.

9. The roadway access drill according to claim 8, further comprising a lifting device for lifting and lowering the roadway access drill.

10. The roadway access drill according to claim 8, wherein the debris containment collar comprising a vacuum attachment for attaching a source of vacuum to the hollow chamber.

\* \* \* \* \*