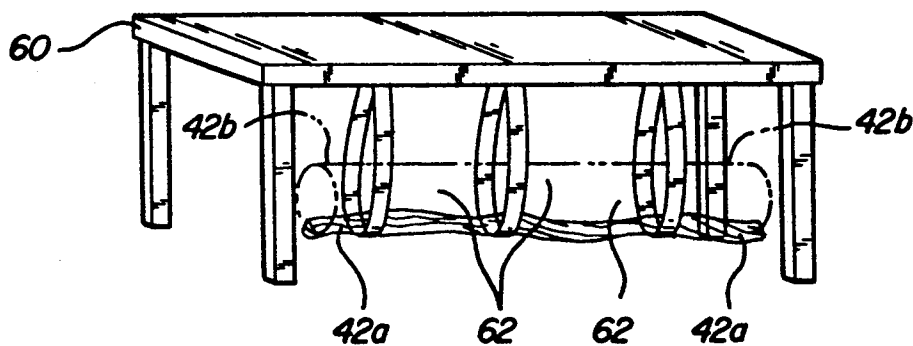

FIG-5



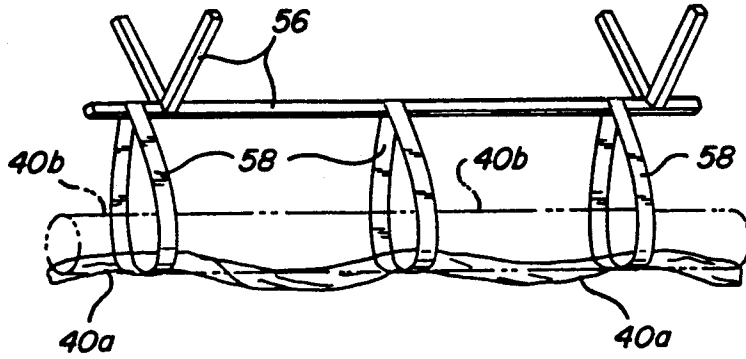

FIG-4

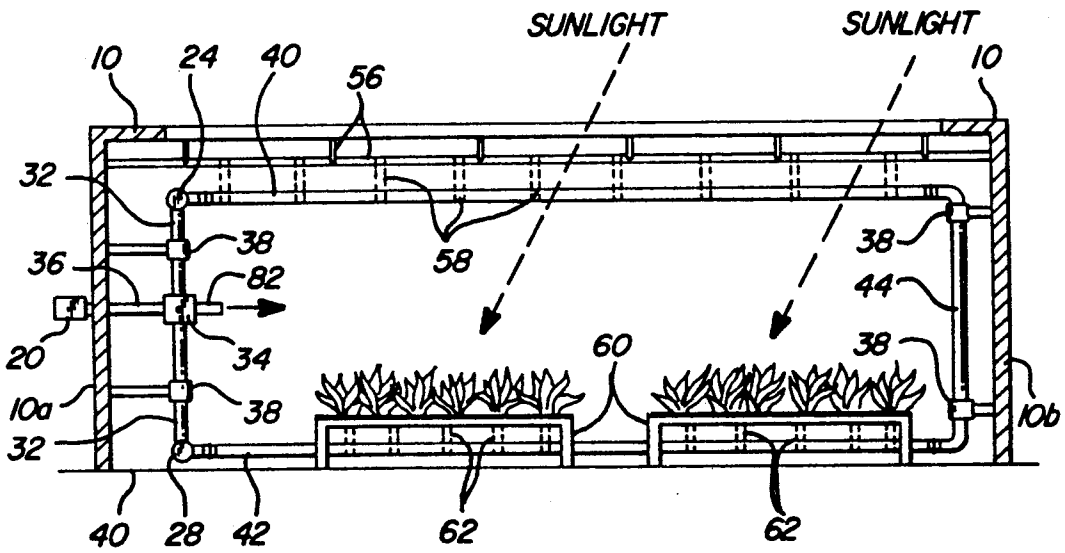

FIG-6

GREENHOUSE HEATING SYSTEM

FIELD OF THE INVENTION

This invention relates to heating systems and, more particularly, to radiant tube heating systems for greenhouses.

BACKGROUND OF THE INVENTION

In order to grow plants in greenhouses, a proper combination of light, heat, and humidity must be maintained. This combination of light, heat, and humidity should be consistent throughout the greenhouse so that plants grow uniformly regardless of position therein. At times, the requisite light and heat are provided naturally from the sun, which projects radiant energy through the elevated window areas of the greenhouse. However, it is often too cold during the winter to grow plants without some source of additional heat, especially in northern climates.

Heat may be provided by forced air heaters which distribute heated air directly into the greenhouse. However, this arrangement is not entirely satisfactory for many reasons. A forced air system unevenly distributes heated air initially in the greenhouse, and tends to concentrate the heat in the areas around the heated air outlets. Further, much of the hot air is lost through the roof and walls of the greenhouse before being dispersed throughout the greenhouse. As a result, during the winter days, the temperature in many areas of the greenhouse can be as low as 50 degrees which results in improper plant development.

Insulating materials have been used on the roof and walls of the greenhouse to address the previously mentioned heat loss problems associated with direct air heating. A system of this type is disclosed in Cary U.S. Pat. No. 4,064,648, and Ward et al U.S. Pat. No. 4,313,650. Such systems typically provide for reflective insulating panels which, at times, may block direct sunlight from entering the greenhouse and produce unwanted shadows therein. Such systems are also unsatisfactory since the plants need uniform heat and light for proper growth.

Radiant heating systems have been used to heat greenhouses. Radiant systems provide an indirect source of heat and are generally capable of having heating elements which can be more precisely positioned within a greenhouse. Radiant heating systems typically employ metallic energy-emitting tubular conduits mounted overhead in an area to be heated. Such systems further include a burner which fires a heated effluent into the conduit, an opaque reflector mounted over the conduit, and an exhaust system to expel the effluent and products of combustion outside the greenhouse. One such radiant heater system is disclosed in Johnson U.S. Pat. No. 3,399,833.

A characteristic of these radiant heating systems is the wide variance in the amount of thermal energy emitted from the conduit over its working length. While the temperature inside the metallic conduit immediately adjacent the burner may reach levels in excess of 1600° F., the temperature inside the conduit at the exhaust end, depending on length, may be as low as 200° F. This results in an uneven emission of thermal energy over the length of the conduit. Unless the spacing of the tube from the area being heated is varied, there are correspondingly uneven temperatures in the area being heated by the system. This is especially true

with low overhead mounted (7'-9') systems in high heat loss structures, such as greenhouses.

One attempt to more evenly distribute the thermal energy radiated by the metallic conduit is disclosed in Prince U.S. Pat. No. 4,319,125. Prince employs a dispersing reflector adjacent to the relatively hot initial portion of the metallic conduit and a parabolic or concentrating reflector adjacent to the colder end portion of the conduit to compensate for the varying intensity of thermal energy radiated over the length of the conduit. While the shaped reflector may provide some measure of improvement in the distribution of the thermal energy throughout the area serviced by the heater system, the opaque conduit and reflector obstruct sunlight entering the greenhouse and produce a shadow which adversely affects the growth of plants thereunder.

SUMMARY OF THE INVENTION

The present invention provides a radiant heating system of relatively simple and inexpensive construction which provides controlled and uniform heating of a greenhouse environment.

According to an important feature of the invention, the radiant heating system includes a tubular conduit which extends to an area to be heated and is formed from a length of gas impermeable plastic tubing. A burner connects to one end of the conduit so that the conduit receives the effluent output from the burner, thereby providing energy which radiates from the conduit. This arrangement provides an inexpensive radiator heating system which maintains a substantially even temperature throughout the length of the conduit.

According to a further feature of the invention, the tubular conduit is arranged overhead and formed from light transmitting material to allow the sunlight projecting into the greenhouse to pass through the conduit without substantially interfering with the transmission of light to the plants grown thereunder. This arrangement maintains a uniform light environment within the greenhouse for consistent plant growth. In the preferred embodiment, the tubing is formed from nylon reinforced polyethylene, or other suitable light transmitting material, so as to allow the use of a readily available inexpensive material for the conduit.

According to a further feature of the invention, the tubing is formed from nonrigid plastic material having a normally collapsed configuration and attains an inflated configuration by the action of the heated effluent transmitted through the tubing. This arrangement allows the tubing to normally assume a collapsed configuration, to facilitate shipping and storage, and yet allows the tubing to assume an inflated configuration in response to the passage of heated effluent therethrough.

According to a further feature of the invention, the system further includes a floor radiator formed of a length of substantially gas impermeable tubing, preferably of plastic although low emission sheet metal tubing may be used since sunlight is not a factor, communicating with the burner and disposed proximate the greenhouse floor and valve means operative to selectively direct the heated effluent from the burner to either the overhead radiator tubing or the floor radiator tubing. This arrangement allows the system to selectively provide radiant heat either to the upper regions of the greenhouse or to the floor regions of the greenhouse.

According to a further feature of the invention, the system further includes exhaust means, the free end of the overhead tubing is connected to the free end of the floor tubing, and the valve means is selectively operative to direct the heated effluent to the overhead tubing for subsequent movement through the floor tubing to the exhaust means or to direct the heated effluent to the floor tubing for subsequent movement through the overhead tubing to the exhaust means. This arrangement allows the heated effluent to be directed through an enclosed loop and allows selection of the direction of movement of the effluent through the loop to the exhaust.

Further, the exhaust means may direct the exhaust effluent either inside or outside of the enclosure depending on the configuration desired. For example, in a greenhouse system it is desirable to minimize heat loss and provide CO₂ for plants to use. As such, exhausting the effluent inside the structure aids in both factors. On the other hand, if the system were placed in a high human traffic area, the exhaust can be directed outside to minimize CO₂ buildup.

An additional related concern involves the placement of the inlet related to the source of heated air effluent for the system. To minimize humidity in the local environment, all or a portion of the ambient air may be ingested by the system. It is important in many applications to control the humidity and thus control the condensation within the structure. By placing the inlet and exhaust outlet either inside or outside the structure, humidity can be effectively controlled.

In the disclosed embodiment of the invention, the valve means is connected to the exhaust means and the burner, the valve means has an overhead outlet and a floor outlet, one end of the tubing of the overhead radiator is connected to the overhead outlet of the valve means, one end of the tubing of the floor radiator is connected to the floor outlet of the valve means, the valve means is configured to selectively direct the heated effluent from the burner to the overhead outlet or to the floor outlet and is further configured to allow the exhaust means to communicate with the outlet other than the outlet selected to receive the heated effluent from the burner. The system further includes connector means having an overhead port and a floor port with the overhead port of the connector means attached to the free end of the overhead radiant and the floor port of the connector means attached to the free end of the tubing of the floor radiator. This specific arrangement provides a simple and effective means for distributing the heated effluent initially through the overhead radiator for subsequent discharge through the floor radiator and exhaust means or to the floor radiator for subsequent discharge through the overhead radiator and the exhaust means.

According to a further feature of the invention, the effluent is heated to a temperature of approximate 200° F. so that the radiant output of the system corresponds to the absorptivity peak of the floor and surrounding equipment and structures which allows these components to reradiate the radiant energy. This arrangement optimizes the heat transfer efficiency of the system.

According to a further feature of the invention, the system includes a manifold communicating with the burner, the manifold has a plurality of upper manifold outlets and a plurality of lower manifold outlets, a corresponding plurality of tubular overhead radiators connect to the upper manifold outlets, a corresponding

plurality of tubular lower radiators connect to the lower manifold outlets, and a plurality of connector members operate to connect one of the overhead radiators to a respective one of the floor radiators. This arrangement provides a plurality of closed loop systems which may be positioned within the enclosure to uniformly and effectively heat the enclosure.

According to a feature of the invention methodology, a source of heated air is provided, one end of a normally non-rigid, collapsed tube is connected to the source of heated air, the tube is positioned within an enclosure to be heated, and heated air is blown from the source through the tube to inflate the tube and provide radiant heat to the enclosure. This methodology provides a ready, efficient and inexpensive means of uniformly heating an enclosure.

According to a further feature of the invention methodology, the step of providing a source of heated air comprises providing a burner and a blower, and the blower operates to blow ambient air through the tube in excess of the amount of air required for complete combustion of the fuel used by the burner so as to regulate the overall temperature of the air blown through the tube. This methodology allows the system to use the non-rigid type tube operating at a temperature below the melting point of associated components.

BRIEF DESCRIPTION OF THE DRAWINGS

These and other objects and aspects of the invention will become apparent in the detailed description of the invention hereinafter with respect to the drawings in which:

FIG. 1 is a perspective view of the invention heating system removed from any related enclosure;

FIG. 2 is a side view of the invention heating system disposed in a greenhouse;

FIG. 3 is a side view of a valve means and blower assembly used in the invention heating system;

FIG. 4 is a detailed view of a section of an overhead radiator used in the invention heating system;

FIG. 5 is a detailed view of a section of a lower radiator used in the invention heating system; and

FIG. 6 is a side view of an alternate configuration of the invention heating system disposed in a greenhouse.

DETAILED DESCRIPTION OF THE PREFERRED EMBODIMENT

The present invention provides for the heating of a greenhouse 10 in an easily assembled, substantially uniform, radiant heating system 12 of relatively simple and inexpensive construction. The heating system 12 is generally composed of a heat generating and distributing assembly 14 and a radiant heating assembly 16. Generally, the heat generating and distributing assembly 14 produces a heated air effluent which is projected through the radiant heating assembly 16 to the area to be heated.

With reference to FIGS. 1 and 2, the heat generating and distributing assembly 14 includes a burner/blower unit 20 and a manifold assembly 22.

Burner/Blower unit 20 includes a blower 70 which operates to project a flow of air from inlet 72 past burner 74 and into connector duct 36. The output of the burner/blower unit 20 is distributed through a valve assembly 34 to a manifold assembly 22 which includes an upper, horizontally disposed, air duct arm 24 having a plurality of outlets 26 distributed along the length thereof; a lower horizontally disposed air duct arm 28

also having a plurality of outlets 30 distributed along the length thereof; a valve assembly 34; a vertically extending duct 32 connecting the valve assembly to upper and lower arms 24, 28; a horizontally extending duct 36 connecting the valve assembly 24 to burner/blower unit 20; and an exhaust duct 82 connecting the valve assembly to the exhaust to the exterior of the greenhouse, through greenhouse end wall 10A. All of the components of the manifold assembly 22 are formed from a metallic material to provide structural strength to the overall system 12 and withstand any direct heat from the burner/blower unit 20.

Valve assembly 34 includes a substantially cubic housing 75 having an internal plate 76 pivoted about a horizontal axis 78 between a first position 76a and a second position 76b by operation of an external nob 80 mounted coaxially on the pivot axis 78. The exhaust duct 82 and connector duct 36 are connected to opposite side walls of the housing and vertical ducts 32 are connected to the top and bottom walls of the housing. The external nob 80 is preferably a motorized unit adapted to pivot internal plate 76 in a controlled manner without the need for physical manipulation.

The heat generating and distributing assembly 14 is disposed proximate end wall 10A of the greenhouse 10 by support arms 38 which engage vertical ducts 32 to position the lower air duct arm 28 and outlets 30 near the greenhouse floor 40. The dimensions of the manifold assembly 22 and, more specifically, the vertical ducts 32 are such that the upper air duct arm 24 and upper outlets 26 are correspondingly positioned at an elevated overhead position above the greenhouse floor 40.

The radiant heating assembly 16 includes a plurality of tubular overhead radiators 40, a corresponding plurality of lower tubular floor radiators 42, and a corresponding plurality of connector tubes 14. The connector tubes 44 are vertically oriented proximate the opposite wall 10B of the greenhouse 10 by additional support arms 38. Each connector tube 44 has an overhead port 48 and lower floor port 50. When the connector tubes 44 are attached to the opposite greenhouse wall the lower floor port 50 is positioned proximate the floor 40 and the upper port 48 is positioned at an elevated overhead position. Each overhead radiator 40 connects at one end to an upper outlet 26 by operation of a clamp 46 which secures the end of the radiator 40 against the outside of the outlet 26 inserted therein. The other end of each overhead radiator 40 attaches in like fashion to an upper connector port 48 using a clamp 46. Similarly, each lower tubular floor radiator 42 connects at one end to a lower outlet 30 of the manifold assembly 22 and at the other end to the floor port 50 of a connector tube 44. The radiant heating section 16 is thereby arranged as a sequence of closed loops formed by related overhead radiators 40, floor radiators 42 and connector tubes 44, which can be positioned in areas of the greenhouse to be heated. Typically, each closed loop of radiators 40, 42 would be positioned to extend above and below a series of one or more tables 60 in the greenhouse 10.

With reference also to FIGS. 4 and 5, each of the tubular radiators 40, 42, are configured as energy-emitting conduits formed from a length of non-rigid, polyethylene tubing having a diameter in the range of 8 to 20 inches to provide substantially gas impermeable plastic radiators 40, 42. The non-rigid polyethylene tubing has a relatively thin wall thickness so as to have a substantially collapsed normal configuration 40A, 42A which

attains an inflated configuration 40B, 42B, by action of the heated air effluent transmitted therethrough.

Further, the non-rigid, polyethylene tubing is substantially transparent so as to transmit light projected therethrough. The large diameter of the radiators 40, 42 provides sufficient surface area directed toward the area to be heated so as not to require an opaque reflector. By this construction, the radiators 40 allow sunlight projecting through the greenhouse window areas to be substantially transmitted through the tubing so as not to interfere with the transmission of light to the plants grown thereunder.

The overhead radiators 40 are suspended from ceiling braces 56 of the greenhouse 10 by hanging flexible plastic bands 58 which support the tubing at intervals along the length of a given overhead radiator 40. The plastic bands 58 are supported by the braces 56 and provide a non-invasive support for the overhead radiator 40 to maintain the integrity of the gas impermeable tubing. Further, the bands 58 are also substantially transparent so that they do not block sunlight.

The lower radiators are similarly suspended below greenhouse tables 60 by hanging strips 62. The tables 60 support the plants in the greenhouse 10, and provide a convenient framework for mounting hanging strips 62 which position the lower radiators 42 in proximity to the plants grown thereon.

With reference also to FIG. 3, since the polyethylene has a low melting point, the burner/blower unit 20 operates to produce a low grade heated air effluent of a temperature below the melting point of the polyethylene. Blower 70 operates to project an amount of air approximately 500% in excess of the amount required for the combustion processes of the burner 74. While the burner 74 may produce output temperatures considerably higher than the melting point of the polyethylene, the overall heated air effluent produced by the burner/blower unit 20 has a temperature below the melting point of the polyethylene as a result of the combination of the burner output and the excess ambient-temperature air.

Preferably, the resulting heated air effluent temperature is approximately 200° F. For example, a propane burner output of 1000 Btu requires approximately 10 cubic feet of air for complete combustion, and an additional 50 cubic feet of ambient air (or 500% excess air) will cool the overall temperature of the resulting effluent to approximately 200° F. Several external factors will vary this relationship, including the type of fuel burned and the temperature of the ambient air. However, this approximate relationship remains.

When plate 76 is positioned in first position 76A a flow of effluent occurs from the blower 70 through the manifold assembly 22 to the overhead radiators 40, through the connector ducts 36 and lower radiators 42 back to the manifold assembly 22, and out the exhaust duct 82 (as shown by solid arrow 84). When the plate 76 occupies the second position 76B the path is substantially reversed and a flow of effluent occurs from the blower 70 through the manifold assembly 22 to the lower radiators 42, through the connector ducts 36 and overhead radiators 40 back to the manifold assembly 22, and out the exhaust duct 82 (as shown by the dashed arrows 86). This allows the operator of the greenhouse to choose the radiator 40, 42 which will receive heated air effluent first and therefore act as the primary radiant heat source (the overhead radiator 40 in position 76A, or the floor radiator 42 in position 76B). The green-

house will further receive secondary, or residual, heating from the radiator 40, 42 which operates later in sequence.

Thus, the radiant heating system 12 provides for selective heating of the greenhouse 10. When the effluent is directed first to the lower floor radiators 42, the radiant heat is directed at the root zone of soil in containers placed on the tables 60. This type of heating is most appropriate for seedling operations where soil temperature is most critical. When the effluent is directed first to the overhead radiators 40, the radiant heat is directed at the plant canopy above the tables 60. This type of heating is most appropriate for more advanced plant growth where environment temperature is most critical.

The low grade 200° F. effluent temperature allows for primary radiator lengths of over 100 feet without substantial loss of effluent temperature over that length. Sufficient heat energy is radiated by a large volume of heated air effluent projected through the tubing and the large surface area of the polyethylene tubing. Further, since the effluent is heated to a temperature of approximately 200° F., the radiant output of the system further corresponds to the absorptivity peak of the floor and allows the floor to reradiate the radiant output of the lower radiators 42.

Preferably, the radiator tubing has a diameter greater than 8 inches, and within the range of 12 to 18 inches to closely match the outlet diameter on the typical burner manifold assembly and to provide sufficient surface area for heating the greenhouse with a convenient number of radiators 40 and 42. However, radiators of various diameters may be used to accommodate different heating configurations and specific heating needs. For example, in high heat loss situations, a large number of small diameter (approximately 4 inch) radiators may be disposed throughout a greenhouse to provide increased radiator surface area for heat transfer so as to more evenly distribute heat therein. Conversely, in low heat loss situations, fewer radiators of possibly larger diameter (up to 36 inches) may be utilized to maintain a minimum amount of radiator surface area for heat transfer. In either case, the apparatus is configured to allow for relatively complete radiant transfer of heat energy to the greenhouse such that the exhaust temperature of the effluent is within approximately 20 degrees or less of the ambient greenhouse temperature so as to be as thermally efficient as practical. Thus, the exact number, diameter, and lengths of the radiators depends upon the specific greenhouse parameters, such as heat loss, size, etc., for the given application.

Further, the exhaust means may direct the exhaust effluent either inside or outside of the enclosure depending on the configuration desired. For example, in a greenhouse system it is desirable to minimize heat loss and provide CO₂ for plants to use. As such, exhausting the effluent inside the structure aids in both factors. On the other hand, if the system were placed in a high human traffic area, the exhaust can be directed outside to minimize CO₂ buildup. Thus, by way of example, in FIG. 2, the exhaust duct 82 terminates outside the enclosure 10 so as to exhaust effluent and products of combustion outside of the enclosure 10, while, in FIG. 6, an alternative construction disposes the end of exhaust duct 82 inside the enclosure 10 to minimize heat loss and provide CO₂ for plants to use.

An additional related concern involves the placement of the inlet related to the source of heated air effluent

for the system. To minimize humidity in the local environment, all or a portion of the ambient air may be ingested by the system. It is important in many applications to control the humidity and thus control the condensation within the structure. By placing the inlet and exhaust outlet either inside or outside the structure, humidity can be effectively controlled. Thus, by way of example, the burner/blower unit 20 may be located inside the enclosure 10 (FIG. 2) or outside the enclosure 10 (FIG. 6) depending on the humidity needs of the structure. It should be noted, that the same function can occur by placing the inlet to the burner/blower unit 20 at a specific location without moving the entire burner/blower unit between the interior and exterior of the structure.

In further alternative embodiments, the greenhouse itself may be a temporary structure, such as a light transmissive tent adapted to be relocatably placed in various areas to protect outdoor plants from external elements, such as frost. In other applications, the enclosures heated with the present system may include other enclosures where the radiators may be exposed to the interior of the building, for example open-area warehouses, garages, or malls.

From the foregoing description of the preferred embodiment it can be seen that various alternative embodiments of the invention can be anticipated without departure from the scope of the invention as defined in the following claims.

We now claim:

1. A radiant heating system including a burner and a tubular energy-emitting conduit extending through an area to be heated and connected at one end thereof to the burner to receive the burner output, characterized in that the conduit comprises a length of tubing formed from a gas impermeable plastic material.
2. A radiant heating system for an enclosure having a burner arranged to transmit a heated effluent through an overhead radiator to heat an area of the greenhouse in proximity to the radiator, characterized in that the overhead radiator is formed from a length of light transmitting tubing which allows sunlight projecting into the greenhouse to be substantially transmitted therethrough.
3. The system of claim 2, wherein said tubing is formed from a substantially gas impermeable plastic material.
4. The system of claim 3, wherein said tubing is formed from polyethylene.
5. The system of claim 3, wherein said tubing is formed from non-rigid plastic material having a normally collapsed configuration and attains an inflated configuration by the action of the heated effluent transmitted therethrough.
6. The system of claim 3, wherein the system further includes:
 - a floor radiator formed of a length of substantially gas impermeable tubing communicating with the burner and disposed proximate to the enclosure floor.
7. The system of claim 6, wherein said floor radiator is formed from a plastic material.
8. The system of claim 6, wherein said overhead radiator and said floor radiator are formed from identical materials.
9. The system of claim 6, wherein said system further includes valve means operative to selectively direct the heated effluent from the

burner to one end of the overhead radiator tubing or to one end of the floor radiator tubing.

10. The system of claim 9, wherein said system further includes exhaust means; the other end of said overhead tubing is connected to the other end of said floor tubing; and said valve means is selectively operative to direct the heated effluent to the overhead tubing for subsequent movement through the floor tubing to the exhaust means or to direct the heated effluent to the floor tubing for subsequent movement through the overhead tubing to the exhaust means.

11. The system of claim 10, wherein said valve means is connected to said exhaust means and said burner, said valve means has an overhead outlet and a floor outlet, said one end of said tubing of said overhead radiator is connected to said overhead outlet, and one end of said tubing of said floor radiator is connected to said floor outlet, said valve means is configured to selectively direct the heated effluent from the burner to said overhead outlet or to said floor outlet, and further is configured to allow said exhaust means to communicate with the outlet other than the outlet selected to receive the heated effluent from the burner; and

said system further includes connector means having an overhead port and a floor port, said overhead port of said connector means being attached to the other end of said tubing of said overhead radiator, and said floor port of said connector means being attached to the other end of said tubing of said floor radiator.

12. The system of claim 2, wherein said light transmitting tubing is substantially transparent.

13. The system of claim 2, wherein said light transmitting tubing has a diameter of at least eight inches.

14. A radiant heating system for an enclosure including a burner, an elongated radiator connected at one end thereof to the burner to receive the burner effluent, and exhaust means at the other end of the radiator to discharge the burner effluent, characterized in that the radiator comprises a length of tubing formed from a substantially gas impermeable plastic material.

15. The system of claim 14, wherein said radiator is disposed overhead; said enclosure comprises a building having elevated window areas; and said substantially gas impermeable plastic material is substantially transparent to allow sunlight projecting through said window areas to be substantially transmitted therethrough.

16. The system of claim 14, wherein said tubing is formed from non-rigid plastic material having a normally collapsed configuration and attains an inflated configuration by the action of the heated effluent transmitted therethrough.

17. The system of claim 14, wherein the enclosure is a greenhouse, further characterized in that: said radiator is disposed proximate to the floor; and said effluent is heated to a temperature of approximately 200° F. so that the radiant output of the system corresponds to the absorptivity peak of the floor and allows the floor to reradiate the radiant output of the radiator.

18. The system of claim 17, wherein

said system further includes a second radiator communicating with the burner to allow heated effluent to be transmitted therethrough, said second radiator being disposed overhead and formed from a length of substantially transparent tubing to allow sunlight projecting into the greenhouse to be substantially transmitted therethrough.

19. The system of claim 18, wherein said system further includes valve means operative to selectively direct the heated effluent from the burner to one end of the overhead radiator tubing or to one end of the floor radiator tubing.

20. The system of claim 19, wherein said system further includes exhaust means; the other end of said overhead tubing is connected to the other end of said floor tubing; and said valve means is selectively operative to direct the heated effluent to the overhead tubing for subsequent movement through the floor tubing to the exhaust means or to direct the heated effluent to the floor tubing for subsequent movement through the overhead tubing to the exhaust means.

21. The system of claim 20, wherein said valve means is connected to said exhaust means and said burner, said valve means has an overhead outlet and a floor outlet, said one end of said tubing of said overhead radiator is connected to said overhead outlet, and said one end of said tubing of said floor radiator is connected to said floor outlet, said valve means is configured to selectively direct the heated effluent from the burner to said overhead outlet or to said floor outlet, and further is configured to allow said exhaust means to communicate with the outlet other than the outlet selected to receive the heated effluent from the burner; and said system further includes connector means having an overhead port and a floor port, said overhead port of said connector means being attached to the other end of said tubing of said overhead radiator, and said floor port of said connector means being attached to the other end of said tubing of said floor radiator.

22. The system of claim 14, wherein said exhaust means is adapted to discharge at least a portion of the burner effluent outside of the enclosure.

23. The system of claim 14, wherein said exhaust means is adapted to discharge at least a portion of the burner effluent inside said enclosure.

24. The system of claim 14, wherein said burner is configured to receive air from inside the enclosure.

25. The system of claim 14, wherein said burner is configured to receive air from outside the enclosure.

26. A radiant heating system for use in greenhouses, comprising:

a blower unit;
a burner arranged to heat the air from said blower unit;

a manifold communicating with said burner and said blower unit and having an upper manifold outlet and a lower manifold outlet;

valve means associated with said manifold to selectively direct heated air to said upper manifold outlet or said lower manifold outlet;

a tubular overhead radiator having first and second ends, said first end communicatively attached to

said upper manifold outlet so that heated air may be transmitted therethrough, said overhead radiator being disposed substantially above the floor of the greenhouse and formed from an elongated length of non-rigid substantially transparent gas impermeable plastic tubing which allows sunlight projecting into the greenhouse to be substantially transmitted therethrough, said tubing having a normally collapsed configuration and attaining an inflated configuration by the action of the heated air transmitted therethrough;

a tubular lower radiator having first and second ends, said first end communicatively attached to said lower manifold outlet so that heated air may be transmitted therethrough, said lower radiator being disposed proximate to the floor of the greenhouse; and

an exhaust system communicatively attaching to said second ends of said overhead and said lower radiators to discharge the heated air.

27. The system of claim 26, wherein said lower radiator is formed from an elongated length of non-rigid substantially gas impermeable plastic tubing which allows the floor to reradiate the radiant output of the radiator, said tubing having a normally collapsed configuration and attaining an inflated configuration by the action of the heated air transmitted therethrough.

28. The system of claim 26, wherein said overhead radiator is formed of polyethylene.

29. The system of claim 27, wherein said lower radiator is formed of polyethylene.

30. The system of claim 26, wherein said burner is operative to heat the air to a predetermined temperature not exceeding the melting point of the radiator material.

31. The system of claim 26, wherein said system further including connector means having an overhead port and a lower port, said overhead port of said connector means being attached to said second end of said overhead radiator, and said lower port of said connector means being attached to said second end of said lower radiator; said valve means is connected to an exhaust outlet; and

said valve means is operative to initially direct the heated air from the burner to either said overhead outlet or to said lower outlet, and is further operative to allow said exhaust outlet to communicate with the outlet other than the outlet selected to initially receive the heated air from the burner.

32. The system of claim 31, wherein said manifold has a plurality of upper manifold outlets and a plurality of lower manifold outlets; a corresponding plurality of tubular overhead radiators connect to said upper manifold outlets; a corresponding plurality of tubular lower radiators connect to said lower manifold outlets; and a plurality of connector means operate to connect one of said overhead radiators to a respective one of said floor radiators.

33. A radiant heating system for an enclosure, comprising:

- a blower unit;
- a burner arranged to heat the air from said blower unit to a predetermined temperature;

a manifold communicating with said burner and blower unit and having an upper manifold outlet and a lower manifold outlet;

an tubular overhead radiator having first and second ends, said first end communicatively attached to said upper manifold outlet so that heated air may be transmitted therethrough;

a tubular lower radiator having first and second ends, said first end communicatively attached to said lower manifold outlet so that heated air may be transmitted therethrough, the second end of said lower radiator connected to the second end of said overhead radiator;

an exhaust system arranged to expel the heated air from the system; and

valve means selectively operative to direct the heated air to the overhead radiator for subsequent movement through the lower radiator to the exhaust system or to direct the heated air to the lower radiator for subsequent movement through the overhead radiator to the exhaust system.

34. The system of claim 33, wherein said exhaust system is adapted to discharge at least a portion of the heated air outside the enclosure.

35. The system of claim 33, wherein said exhaust system is adapted to discharge at least a portion of the heated air inside the enclosure.

36. The system of claim 33, wherein said blower unit is adapted to receive air from outside of said enclosure.

37. The system of claim 33, wherein said blower unit is adapted to receive air from inside of said enclosure.

38. A radiant heating system for an enclosure, comprising:

- a blower unit;
- a burner arranged to heat the air from said blower unit to a predetermined temperature;

a manifold communicating with said burner and blower unit and having an upper manifold outlet, a lower manifold outlet, and an exhaust outlet;

a tubular overhead radiator having first and second ends, said first end communicatively attached to said upper manifold outlet so that heated air may be transmitted therethrough;

a tubular lower radiator having first and second ends, said first end communicatively attached to said lower manifold outlet so that heated air may be transmitted therethrough;

connector means having an overhead port and a lower port, said overhead port communicatively attached to said second end of said overhead radiator, and said lower port communicatively attached to said second end of said lower radiator;

an exhaust system attached to the exhaust outlet of said manifold arranged to expel the heated air apart from the system; and

valve means associated with said manifold operative to selectively direct the heated air from the burner initially to said overhead outlet or to said lower outlet, and further being operative to allow said exhaust outlet to communicate with the outlet other than the outlet selected to initially receive the heated air from the burner.

39. The system of claim 38, wherein said overhead radiator is formed from a length of light transmitting tubing which allows sunlight

13

projecting into the enclosure to be substantially transmitted therethrough.

40. The system of claim 39, wherein said light transmitting tubing is substantially transparent.

41. The system of claim 40, wherein the radiator comprises a length of tubing formed from a substantially gas impermeable plastic material.

42. The system of claim 38, wherein

5

10

15

20

25

30

35

40

45

50

55

60

65

14

said lower radiator comprises a length of tubing formed from a substantially gas impermeable plastic material.

43. The system of claim 38, wherein said manifold has a plurality of upper manifold outlets and a plurality of lower manifold outlets; a corresponding plurality of tubular overhead radiators connect to said upper manifold outlets; a corresponding plurality of tubular lower radiators connect to said lower manifold outlets; and a plurality of connector means operate to connect one of said overhead radiators to a respective one of said floor radiators.

* * * * *