



(11) **EP 2 736 206 A1**

(12) **EUROPEAN PATENT APPLICATION**
published in accordance with Art. 153(4) EPC

(43) Date of publication:
28.05.2014 Bulletin 2014/22

(51) Int Cl.:
H04L 27/00^(2006.01) H02J 17/00^(2006.01)
H04B 5/02^(2006.01)

(21) Application number: **11869517.0**

(86) International application number:
PCT/KR2011/005330

(22) Date of filing: **20.07.2011**

(87) International publication number:
WO 2013/012111 (24.01.2013 Gazette 2013/04)

(84) Designated Contracting States:
AL AT BE BG CH CY CZ DE DK EE ES FI FR GB GR HR HU IE IS IT LI LT LU LV MC MK MT NL NO PL PT RO RS SE SI SK SM TR

- **CHU, Inchang**
Seoul 151-050 (KR)
- **SEO, Jeongkyo**
Anyang-si
Gyeonggi-do 431-742 (KR)

(71) Applicant: **LG Electronics Inc.**
Seoul 150-721 (KR)

(74) Representative: **Katérle, Axel et al**
Wuesthoff & Wuesthoff
Patent- und Rechtsanwälte
Schweigerstraße 2
81541 München (DE)

(72) Inventors:
• **LEE, Jaesung**
Inje-gun
Gangwon-do 252-902 (KR)

(54) **TWO-WAY COMMUNICATION USING WIRELESS POWER SIGNAL**

(57) The present description relates to an apparatus for transmitting wireless power and a method for same, comprising: a power transmission control portion for generating a packet comprising data for at least one electronic device; a modulation/demodulation portion for modulating a carrier signal so as to comprise the packet that is generated; and a power conversion portion for forming the wireless power signal for transmitting power, based on the carrier signal that is modulated, wherein the power transmission control portion transmits the

packet to the at least one electronic device through the wireless power signal. Also, the present description relates to the electronic device and a method for receiving power by same, comprising: a power reception portion for receiving the wireless power signal from the apparatus for transmitting wireless power; a modulation/demodulation portion for demodulating the packet which is comprised in the wireless power signal; and a power reception control portion for obtaining data based on the packet that is demodulated.

FIG. 11

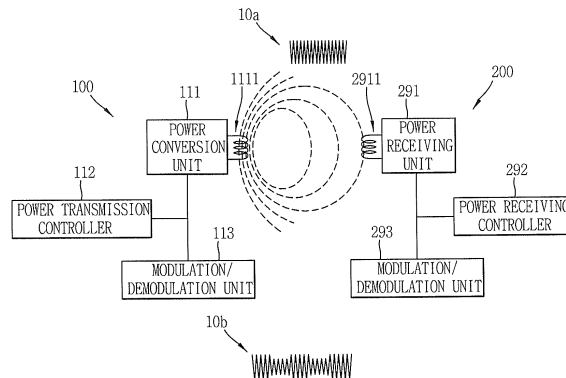

EP 2 736 206 A1

Description**TECHNICAL FIELD**

[0001] The present disclosure relates to wireless power transmission, and more particularly, to communication using a signal for power transmission in the wireless power transmission.

BACKGROUND ART

[0002] In recent years, the method of contactlessly supplying electrical energy to electronic devices in a wireless manner has been used instead of the traditional method of supplying electrical energy in a wired manner. The electronic device receiving energy in a wireless manner may be directly driven by the received wireless power, or a battery may be charged by using the received wireless power, then allowing the electronic device to be driven by the charged power.

DISCLOSURE OF THE INVENTION

[0003] The present disclosure discloses a wireless power transmitter for generating and modulating a packet containing data for at least one or more electronic devices, and forming a wireless power signal based on this to transmit the wireless power signal to one or more electronic devices in wireless power transmission, and a method thereof.

[0004] Furthermore, the present disclosure discloses an electronic device for receiving a wireless power signal from a wireless power transmitter, and demodulating a packet contained in the wireless power signal to acquire data from the wireless power transmitter based on this in wireless power transmission, and a method thereof.

[0005] A wireless power transmitter according to an embodiment disclosed in the present disclosure may include a power transmission controller configured to generate a packet containing data for one or more electronic devices, a modulation/demodulation unit configured to modulate a carrier signal to contain the generated packet, a power conversion unit configured to form a wireless power signal for power transmission based on the modulated carrier signal, wherein the power transmission controller transmits the packet to the one or more electronic devices through the wireless power signal.

[0006] According to an embodiment, the power conversion unit may receive a wireless power signal modulated by the one or more electronic devices, and the modulation/demodulation unit may demodulate the received wireless power signal.

[0007] According to an embodiment, the generated packet may include a destination address, and the destination address may indicate an electronic device for transmitting the data among the one or more electronic devices.

[0008] According to an embodiment, the destination

address may be an identifier of an electronic device for receiving the data or an identifier of a group to which one or more electronic devices for receiving the data belong.

[0009] According to an embodiment, the power transmission controller may determine status information on the electronic device according to whether or not a response packet for the data is received within an expiration period of time from the electronic device corresponding to the destination address.

[0010] According to an embodiment, the power transmission controller may determine the status information on the electronic device as a removed state when the response packet is not received from the electronic device corresponding to the destination address within the expiration period of time.

[0011] According to an embodiment, the power transmission controller may determine the status information on the electronic device as a normal state when the response packet is received from the electronic device corresponding to the destination address within the expiration period of time.

[0012] According to an embodiment, the power transmission controller may generate packets containing the destination addresses of electronic devices, respectively, having the status information of a normal state, and sequentially transmit the generated packets to electronic devices corresponding to the packets, respectively.

[0013] On the other hand, an electronic device according to an embodiment disclosed in the present disclosure may include a power receiver configured to receive a wireless power signal from a wireless power transmitter, a modulation/demodulation unit configured to demodulate a packet contained in the wireless power signal, and a power receiving controller configured to acquire data based on the demodulated packet.

[0014] According to an embodiment, the power receiving controller may transmit a response packet corresponding to the acquired data to the wireless power transmitter.

[0015] According to an embodiment, the packet may include a destination address.

[0016] According to an embodiment, the power receiving controller may determine whether or not to respond based on the destination address, and the determination of whether or not to respond may determine whether the destination address indicates an identifier of the electronic device or an identifier of a group to which the electronic device belongs.

[0017] According to an embodiment, the power receiving controller may transmit the response packet to the wireless power transmitter when a response is required as a result of the determination of whether or not to respond.

[0018] According to an embodiment, the modulation/demodulation unit may modulate the received wireless power signal, and the response packet may be modulated by the modulation/demodulation unit to be contained in the received wireless power signal for transmis-

sion.

[0019] On the other hand, a wireless power transmission method according to an embodiment disclosed in the present disclosure may include forming a first wireless power signal for power transmission, and transmitting the first wireless power signal to a first electronic device, wherein the first wireless power signal is formed based on a carrier signal modulated to contain a data packet generated for the first electronic device, and the packet is transmitted to the first electronic device through the first wireless power signal.

[0020] According to an embodiment, the packet may include a destination address, wherein destination address is information indicating the first electronic device.

[0021] According to an embodiment, the destination address may be an identifier of the first electronic device or an identifier of a group to which the first electronic device belongs.

[0022] According to an embodiment, the wireless power transmission method may further include determining whether or not a response packet for the data has been received within an expiration period of time from the first electronic device.

[0023] According to an embodiment, the wireless power transmission method may further include determining status information on the first electronic device as a removed state when the response packet is not received within the expiration period of time from the first electronic device.

[0024] According to an embodiment, the wireless power transmission method may further include determining status information on the first electronic device as a normal state when the response packet is received within the expiration period of time from the first electronic device.

[0025] According to an embodiment, the wireless power transmission method may further include modulating the response packet received from the first electronic device.

[0026] According to an embodiment, the wireless power transmission method may further include forming a second wireless power signal for power transmission, and transmitting the second wireless power signal to a second electronic device, wherein the second wireless power signal is formed based on a carrier signal modulated to contain a data packet generated for the second electronic device, and the packet is transmitted to the second electronic device through the second wireless power signal.

[0027] On the other hand, a wireless power receiving method according to an embodiment disclosed in the present disclosure may include receiving a wireless power signal from a wireless power transmitter, demodulating a packet contained in the wireless power signal, and acquiring data based on the demodulated packet.

[0028] According to an embodiment, the wireless power receiving method may further include transmitting a response packet corresponding to the acquired data to

the wireless power transmitter.

[0029] According to an embodiment, the packet may include a destination address.

[0030] According to an embodiment, the wireless power receiving method may further include determining whether or not to respond based on the destination address, wherein the determination of whether or not to respond determines whether the destination address indicates an identifier of the electronic device or an identifier of a group to which the electronic device belongs.

[0031] According to an embodiment, said transmitting a response packet may transmit the response packet to the wireless power transmitter when a response is required as a result of the determination of whether or not to respond.

[0032] According to an embodiment, said transmitting a response packet may modulate the received wireless power signal, and the response packet may be modulated to be contained in the received wireless power signal for transmission.

[0033] According to an embodiment, the response packet may be transmitted to the wireless power transmitter within an expiration period of time.

[0034] According to an embodiment disclosed in the present disclosure, when a wireless power transmitter supplies power to one or more electronic devices in a wireless manner, it may be possible to provide two-way communication in which a data packet is transmitted and received between the wireless power transmitter and the one or more electronic devices using a wireless power signal that transmits power.

[0035] In particular, according to a wireless power transmitter and an electronic device disclosed in the present disclosure, it may be possible to identify a specific electronic device for transmitting a wireless power signal among the one or more electronic devices using two-way communication. Furthermore, according to a wireless power transmitter and an electronic device disclosed in the present disclosure, it may be possible to control a wireless power signal transmitted to a specific electronic device among the one or more electronic devices using two-way communication.

BRIEF DESCRIPTION OF THE DRAWINGS

[0036]

FIG. 1 is an exemplary view conceptually illustrating a wireless power transmitter and an electronic device according to the embodiments of the present invention;

FIG. 2A is an exemplary block diagram illustrating the configuration of a wireless power transmitter that can be employed in the embodiments disclosed herein;

FIG. 2B is an exemplary block diagram illustrating the configuration of an electronic device that can be employed in the embodiments disclosed herein;

FIG. 3 is a view illustrating a concept in which power is transferred from a wireless power transmitter to an electronic device in a wireless manner according to an inductive coupling method;

FIG. 4A is an exemplary block diagram illustrating part of the configuration of the wireless power transmitter in an electromagnetic induction method that can be employed in the embodiments disclosed herein;

FIG. 4B is an exemplary block diagram illustrating part of the configuration of the electronic device in an electromagnetic induction method that can be employed in the embodiments disclosed herein;

FIG. 5 is a block diagram illustrating a wireless power transmitter configured to have one or more transmission coils receiving power according to an inductive coupling method that can be employed in the embodiments disclosed herein;

FIG. 6 is a view illustrating a concept in which power is transferred to an electronic device from a wireless power transmitter in a wireless manner according to a resonance coupling method;

FIG. 7A is an exemplary block diagram illustrating part of the configuration of the wireless power transmitter in a resonance method that can be employed in the embodiments disclosed herein;

FIG. 7B is an exemplary block diagram illustrating part of the configuration of the electronic device in a resonance method that can be employed in the embodiments disclosed herein;

FIG. 8 is a block diagram illustrating a wireless power transmitter configured to have one or more transmission coils receiving power according to a resonance coupling method that can be employed in the embodiments disclosed herein;

FIG. 9 is a block diagram illustrating a wireless power transmitter further including an additional element in addition to the configuration illustrated in FIG. 2A;

FIG. 10 is view illustrating a configuration in case where an electronic device according to the embodiments disclosed herein is implemented in the form of a mobile terminal;

FIG. 11 is a view illustrating a two-way communication concept using a wireless power signal between a wireless power transmitter and an electronic device according to the embodiments disclosed herein;

FIG. 12 is a conceptual view illustrating the process of allowing an electronic device to transmit a packet to a wireless power transmitter according to the embodiments disclosed herein;

FIG. 13A is a view illustrating a method of allowing the wireless power transmitter to modulate a packet containing a power control message;

FIG. 13B is a view illustrating a method of allowing the wireless power transmitter to display a data bit constituting a packet containing a power control message;

FIG. 13C is a view illustrating a method of allowing

the wireless power transmitter to display a byte constituting a packet containing a power control message;

FIG. 14A is a view illustrating the structure of a command packet used in two-way communication using a wireless power signal according to the embodiments disclosed herein;

FIG. 14B is a view illustrating the detailed configuration of a command packet used in two-way communication using a wireless power signal according to the embodiments disclosed herein;

FIG. 14C is a view illustrating the structure of a packet to which a preamble and a checksum used in two-way communication using a wireless power signal are added according to the embodiments disclosed herein;

FIG. 15 is a conceptual view illustrating the process of allowing a wireless power transmitter to transmit a packet to an electronic device according to the embodiments disclosed herein;

FIG. 16 is a conceptual view illustrating the process of allowing a wireless power transmitter to transmit a packet to an electronic device based on the flow of time according to the embodiments disclosed herein;

FIG. 17 is a view illustrating a two-way communication concept using a wireless power signal between a wireless power transmitter and one or electronic devices according to the embodiments disclosed herein;

FIG. 18 is a conceptual view illustrating the process of allowing a wireless power transmitter to transmit a packet to one or more electronic devices based on the flow of time according to the embodiments disclosed herein;

FIG. 19A is a flow chart illustrating the process of allowing a wireless power transmitter to perform two-way communication with one or more electronic devices using a wireless power signal according to the embodiments disclosed herein;

FIG. 19B is a flow chart illustrating the process of allowing an electronic device to perform two-way communication with an wireless power transmitter using a wireless power signal according to the embodiments disclosed herein; and

FIG. 20 is a view illustrating the operation phases of the wireless power transmitter and electronic device according to the embodiments disclosed herein.

MODES FOR CARRYING OUT THE PREFERRED EMBODIMENTS

[0037] The technologies disclosed herein may be applicable to wireless power transfer (contactless power transfer). However, the technologies disclosed herein are not limited to this, and may be also applicable to all kinds of power transmission systems and methods, wireless charging circuits and methods to which the techno-

logical spirit of the technology can be applicable, in addition to the methods and apparatuses using power transmitted in a wireless manner.

[0038] It should be noted that technological terms used herein are merely used to describe a specific embodiment, but not to limit the present invention. Also, unless particularly defined otherwise, technological terms used herein should be construed as a meaning that is generally understood by those having ordinary skill in the art to which the invention pertains, and should not be construed too broadly or too narrowly. Furthermore, if technological terms used herein are wrong terms unable to correctly express the spirit of the invention, then they should be replaced by technological terms that are properly understood by those skilled in the art. In addition, general terms used in this invention should be construed based on the definition of dictionary, or the context, and should not be construed too broadly or too narrowly.

[0039] Incidentally, unless clearly used otherwise, expressions in the singular number include a plural meaning. In this application, the terms "comprising" and "including" should not be construed to necessarily include all of the elements or steps disclosed herein, and should be construed not to include some of the elements or steps thereof, or should be construed to further include additional elements or steps.

[0040] In addition, a suffix "module" or "unit" used for constituent elements disclosed in the following description is merely intended for easy description of the specification, and the suffix itself does not give any special meaning or function.

[0041] Furthermore, the terms including an ordinal number such as first, second, etc. can be used to describe various elements, but the elements should not be limited by those terms. The terms are used merely for the purpose to distinguish an element from the other element. For example, a first element may be named to a second element, and similarly, a second element may be named to a first element without departing from the scope of right of the invention.

[0042] Hereinafter, preferred embodiments of the present invention will be described in detail with reference to the accompanying drawings, and the same or similar elements are designated with the same numeral references regardless of the numerals in the drawings and their redundant description will be omitted.

[0043] In describing the present invention, moreover, the detailed description will be omitted when a specific description for publicly known technologies to which the invention pertains is judged to obscure the gist of the present invention. Also, it should be noted that the accompanying drawings are merely illustrated to easily explain the spirit of the invention, and therefore, they should not be construed to limit the spirit of the invention by the accompanying drawings.

Conceptual view of wireless power transmitter and electronic device

[0044] FIG. 1 is an exemplary view conceptually illustrating a wireless power transmitter and an electronic device according to the embodiments of the present invention.

[0045] Referring to FIG. 1, the wireless power transmitter 100 may be a power transfer apparatus configured to transfer power required for the electronic device 200 in a wireless manner.

[0046] Furthermore, the wireless power transmitter 100 may be a wireless charging apparatus configured to charge a battery of the electronic device 200 by transferring power in a wireless manner. A case where the wireless power transmitter 100 is a wireless charging apparatus will be described later with reference to FIG. 9.

[0047] Additionally, the wireless power transmitter 100 may be implemented with various forms of apparatuses transferring power to the electronic device 200 requiring power in a contactless state.

[0048] The electronic device 200 is a device that is operable by receiving power from the wireless power transmitter 100 in a wireless manner. Furthermore, the electronic device 200 may charge a battery using the received wireless power.

[0049] On the other hand, an electronic device for receiving power in a wireless manner as described herein should be construed broadly to include a portable phone, a cellular phone, a smart phone, a personal digital assistant (PDA), a portable multimedia player (PMP), a tablet, a multimedia device, or the like, in addition to an input/output device such as a keyboard, a mouse, an audio-visual auxiliary device, and the like.

[0050] The electronic device 200, as described later, may be a mobile communication terminal, (for example, a portable phone, a cellular phone, and a tablet or multimedia device). In case where the electronic device is a mobile terminal, it will be described later with reference to FIG. 10.

[0051] On the other hand, the wireless power transmitter 100 may transfer power in a wireless manner without mutual contact to the electronic device 200 using one or more wireless power transfer methods. In other words, the wireless power transmitter 100 may transfer power using at least one of an inductive coupling method based on magnetic induction phenomenon by the wireless power signal and a magnetic resonance coupling method based on electromagnetic resonance phenomenon by a wireless power signal at a specific frequency.

[0052] Wireless power transfer in the inductive coupling method is a technology transferring power in a wireless manner using a primary coil and a secondary coil, and refers to the transmission of power by inducing a current from a coil to another coil through a changing magnetic field by a magnetic induction phenomenon.

[0053] Wireless power transfer in the inductive coupling method refers to a technology in which the elec-

tronic device 200 generates resonance by a wireless power signal transmitted from the wireless power transmitter 100 to transfer power from the wireless power transmitter 100 to the wireless power receiver 200 by the resonance phenomenon.

[0054] Hereinafter, the wireless power transmitter 100 and electronic device 200 according to the embodiments disclosed herein will be described in detail. In assigning reference numerals to the constituent elements in each of the following drawings, the same reference numerals will be used for the same constituent elements even though they are shown in a different drawing.

[0055] FIG. 2 is a block diagram illustrating the configuration of a wireless power transmitter 100 and an electronic device 200 that can be employed in the embodiments disclosed herein.

Wireless power transmitter

[0056] Referring to FIG. 2A, the wireless power transmitter 100 may include a power transmission unit 110. The power transmission unit 110 may include a power conversion unit 111 and a power transmission control unit 112.

[0057] The power conversion unit 111 transfers power supplied from a transmission side power supply unit 190 to the electronic device 200 by converting it into a wireless power signal. The wireless power signal transferred by the power conversion unit 111 is generated in the form of a magnetic field or electro-magnetic field having an oscillation characteristic. For this purpose, the power conversion unit 111 may be configured to include a coil for generating the wireless power signal.

[0058] The power conversion unit 111 may include a constituent element for generating a different type of wireless power signal according to each power transfer method.

[0059] According to some embodiments, the power conversion unit 111 may include a primary coil for forming a changing magnetic field to induce a current to a secondary coil of the electronic device 200. Furthermore, the power conversion unit 111 may include a coil (or antenna) for forming a magnetic field having a specific resonant frequency to generate a resonant frequency in the electronic device 200 according to the resonance coupling method.

[0060] Furthermore, according to some embodiments, the power conversion unit 111 may transfer power using at least one of the foregoing inductive coupling method and the resonance coupling method.

[0061] Among the constituent elements included in the power conversion unit 111, those for the inductive coupling method will be described later with reference to FIGS. 4 and 5, and those for the resonance coupling method will be described with reference to FIGS. 7A and 8.

[0062] On the other hand, the power conversion unit 111 may further include a circuit for controlling the char-

acteristics of a used frequency, an applied voltage, an applied current or the like to form the wireless power signal. The power conversion unit 111 may form a wireless power signal based on a carrier signal modulated from the circuit.

[0063] Furthermore, according to some embodiments, the power conversion unit 111 may receive a wireless power signal modulated by the electronic device 200.

[0064] The power transmission control unit 112 controls each of the constituent elements included in the power transmission unit 110. The power transmission control unit 112 may be implemented to be integrated into another control unit (not shown) for controlling the wireless power transmitter 100.

[0065] On the other hand, a region to which the wireless power signal can be approached may be divided into two types. First, an active area denotes a region through which a wireless power signal transferring power to the electronic device 200 is passed. Next, a semi-active area denotes an interest region in which the wireless power transmitter 100 can detect the existence of the electronic device 200. Here, the power transmission control unit 112 may detect whether the electronic device 200 is placed in the active area or detection area or removed from the area. Specifically, the power transmission control unit 112 may detect whether or not the electronic device 200 is placed in the active area or detection area using a wireless power signal formed from the power conversion unit 111 or a sensor separately provided therein. For instance, the power transmission control unit 112 may detect the presence of the electronic device 200 by monitoring whether or not the characteristic of power for forming the wireless power signal is changed by the wireless power signal, which is affected by the electronic device 200 existing in the detection area. However, the active area and detection area may vary according to the wireless power transfer method such as an inductive coupling method, a resonance coupling method, and the like.

[0066] The power transmission control unit 112 may perform the process of identifying the electronic device 200 or determine whether to start wireless power transfer according to a result of detecting the existence of the electronic device 200.

[0067] Furthermore, the power transmission control unit 112 may determine at least one characteristic of a frequency, a voltage, and a current of the power conversion unit 111 for forming the wireless power signal. The determination of the characteristic may be carried out by a condition at the side of the wireless power transmitter 100 or a condition at the side of the electronic device 200. According to some embodiments, the power transmission control unit 112 may decide the characteristic based on device identification information. In another exemplary embodiment, the power transmission control unit 112 may decide the characteristic based on required power information of the electronic device 200 or profile information related to the required power. The power transmission control unit 112 may receive a power control

message from the electronic device 200. The power transmission control unit 112 may determine at least one characteristic of a frequency, a voltage and a current of the power conversion unit 111 based on the received power control message, and additionally perform other control operations based on the power control message.

[0068] For example, the power transmission control unit 112 may determine at least one characteristic of a frequency, a voltage and a current used to form the wireless power signal according to the power control message including at least one of rectified power amount information, charging state information and identification information in the electronic device 200.

[0069] Furthermore, as another control operation using the power control message, the wireless power transmitter 100 may perform a typical control operation associated with wireless power transfer based on the power control message. For example, the wireless power transmitter 100 may receive information associated with the electronic device 200 to be auditorily or visually outputted through the power control message, or receive information required for authentication between devices.

[0070] According to some embodiments, the power transmission control unit 112 may receive the power control message through the wireless power signal. In other exemplary embodiment, the power transmission control unit 112 may receive the power control message through a method for receiving user data.

[0071] In order to receive the foregoing power control message, the wireless power transmitter 100 may further include a modulation/demodulation unit 113 electrically connected to the power conversion unit 111.

[0072] Furthermore, the modulation/demodulation unit 113 may modulate a wireless power signal that has been modulated by the electronic device 200 and use it to receive the power control message. The method for allowing the power conversion unit 111 to receive a power control message using a wireless power signal will be described later with reference to FIGS. 12 through 14.

[0073] In addition, the power transmission control unit 112 may acquire a power control message by receiving user data including a power control message by a communication means (not shown) included in the wireless power transmitter 100.

[0074] On the other hand, the wireless power transmitter 100 may transmit a packet to the electronic device 200 through the wireless power signal. Specifically, the power transmission controller 112 of the wireless power transmitter 100 may control each constituent elements included in the power transmission unit 110 to transmit a message for the electronic device 200 through a wireless power signal formed by the power conversion unit 111.

[0075] The packet transmission of the wireless power transmitter 100 may be implemented by modulating the wireless power signal. The power transmission controller 112 may modulate a signal entered to the power conversion unit 111, thereby forming a wireless power signal

containing a packet for the electronic device 200.

[0076] Specifically, the power transmission controller 112 may control the modulation/demodulation unit 113 to modulate a carrier signal entered to the power conversion unit 111 to contain a packet for the electronic device 200. Then, the power conversion unit 111 that has received the modulated carrier signal may form a wireless power signal containing the packet.

10 Electronic device

[0077] Referring to FIG. 2B, the electronic device 200 may include a power supply unit 290. The power supply unit 290 supplies power required for the operation of the electronic device 200. The power supply unit 290 may include a power receiving unit 291 and a power receiving controller 292.

[0078] The power receiving unit 291 receives power transferred from the wireless power transmitter 100 in a wireless manner.

[0079] The power receiving unit 291 may include constituent elements required to receive the wireless power signal according to a wireless power transfer method. Furthermore, the power receiving unit 291 may receive power according to at least one wireless power transfer method, and in this case, the power receiving unit 291 may include constituent elements required for each method.

[0080] First, the power receiving unit 291 may include a coil for receiving a wireless power signal transferred in the form of a magnetic field or electromagnetic field having a vibration characteristic.

[0081] For instance, as a constituent element according to the inductive coupling method, the power receiving unit 291 may include a secondary coil to which a current is induced by a changing magnetic field. According to some embodiments, the power receiving unit 291, as a constituent element according to the resonance coupling method, may include a coil and a resonant circuit in which resonance phenomenon is generated by a magnetic field having a specific resonant frequency.

[0082] However, in some embodiments, when the power receiving unit 291 receives power according to at least one wireless power transfer method, the power receiving unit 291 may be implemented to receive power by using a coil, or implemented to receive power by using a coil formed differently according to each power transfer method.

[0083] Among the constituent elements included in the power receiving unit 291, those for the inductive coupling method will be described later with reference to FIG. 4B, and those for the resonance coupling method with reference to FIG. 7B.

[0084] On the other hand, the power receiving unit 291 may further include a rectifier and a regulator to convert the wireless power signal into a direct current. Furthermore, the power receiving unit 291 may further include a circuit for protecting an overvoltage or overcurrent from

being generated by the received power signal.

[0085] The power receiving controller 292 may control each constituent element included in the power supply unit 290.

[0086] Specifically, the power receiving controller 292 may transfer a power control message to the wireless power transmitter 100. The power control message may instruct the wireless power transmitter 100 to initiate or terminate a transfer of the wireless power signal. Furthermore, the power control message may instruct the wireless power transmitter 100 to control a characteristic of the wireless power signal.

[0087] According to some embodiments, the power receiving controller 292 may transmit the power control message through the wireless power signal. In another exemplary embodiment, the power receiving controller 292 may transmit the power control message through a method for transmitting user data.

[0088] In order to transmit the foregoing power control message or response packet, the electronic device 200 may further include a modulation/demodulation unit 293 electrically connected to the power receiving unit 291. The modulation/demodulation unit 293, similarly to the case of the wireless power transmitter 100, may be used to transmit the power control message through the wireless power signal. The power communications modulation/demodulation unit 293 may be used as a means for controlling a current and/or voltage flowing through the power conversion unit 111 of the wireless power transmitter 100. Hereinafter, a method for allowing the power communications modulation/demodulation unit 113 or 293 at the side of the wireless power transmitter 100 and at the side of the electronic device 200, respectively, to be used to transmit and receive a power control message through a wireless power signal will be described.

[0089] A wireless power signal formed by the power conversion unit 111 is received by the power receiving unit 291. At this time, the power receiving controller 292 controls the power communications modulation/demodulation unit 293 at the side of the electronic device 200 to modulate the wireless power signal. For instance, the power receiving controller 292 may perform a modulation process such that a power amount received from the wireless power signal is varied by changing a reactance of the power communications modulation/demodulation unit 293 connected to the power receiving unit 291. The change of a power amount received from the wireless power signal results in the change of a current and/or voltage of the power conversion unit 111 for forming the wireless power signal. At this time, the modulation/demodulation unit 113 at the side of the wireless power transmitter 100 may detect a change of the current and/or voltage to perform a demodulation process.

[0090] In other words, the power receiving controller 292 may generate a packet including a power control message intended to be transferred to the wireless power transmitter 100 and modulate the wireless power signal to allow the packet to be included therein, and the power

transmission control unit 112 may decode the packet based on a result of performing the demodulation process of the power communications modulation/demodulation unit 113 to acquire the power control message included in the packet. The detailed method of allowing the wireless power transmitter 100 to acquire the power control message will be described later with reference to FIGS. 12 through 14.

[0091] In addition, according to some embodiments, the power receiving controller 292 may transmit a power control message to the wireless power transmitter 100 by transmitting user data including the power control message by a communication means (not shown) included in the electronic device 200.

[0092] On the other hand, the power receiving controller 292 may receive data transferred through a wireless power signal from the power transmission unit 110. As described above, the wireless power transmitter 100 may perform modulation to form a wireless power signal containing data desired to be transmitted to the electronic device 200.

[0093] Specifically, the power receiving controller 292 may acquire data based on a packet contained in a wireless power signal received from the wireless power transmitter 100.

[0094] In addition, the power supply unit 290 may further include a charger 298 and a battery 299.

[0095] The electronic device 200 that receives power for operation from the power supply unit 290 may be operated by power transferred from the wireless power transmitter 100 or may be operated by power charged to the battery 299 subsequent to charging the battery 299 using the transferred power. At this time, the power receiving controller 292 may control the charger 298 to perform charging using the transferred power.

[0096] Hereinafter, a wireless power transmitter and an electronic device applicable to the embodiments disclosed herein will be described.

[0097] First, a method of allowing the wireless power transmitter to transfer power to the electronic device according to the inductive coupling method will be described with reference to FIGS. 3 through 5.

Inductive coupling method

[0098] FIG. 3 is a view illustrating a concept in which power is transferred from a wireless power transmitter to an electronic device in a wireless manner according to an inductive coupling method.

[0099] When the power of the wireless power transmitter 100 is transferred in an inductive coupling method, if the strength of a current flowing through a primary coil within the power transmission unit 110 is changed, then a magnetic field passing through the primary coil will be changed by the current. The changed magnetic field generates an induced electromotive force at a secondary coil in the electronic device 200.

[0100] According to the foregoing method, the power

conversion unit 111 of the wireless power transmitter 100 may include a transmitting (Tx) coil 1111 a being operated as a primary coil in magnetic induction. Furthermore, the power receiving unit 291 of the electronic device 200 may include a receiving (Rx) coil 2911a being operated as a secondary coil in magnetic induction.

[0101] First, the wireless power transmitter 100 and electronic device 200 are disposed in such a manner that the transmitting coil 1111 a at the side of the wireless power transmitter 100 and the receiving coil at the side of the electronic device 200 are located adjacent to each other. Then, if the power transmission control unit 112 controls a current of the transmitting coil 1111 a to be changed, then the power receiving unit 291 controls power to be supplied to the electronic device 200 using an electromotive force induced to the receiving coil 2911 a.

[0102] The efficiency of wireless power transfer by the inductive coupling method may be little affected by a frequency characteristic, but affected by an alignment and distance between the wireless power transmitter 100 and the electronic device 200 including each coil.

[0103] On the other hand, in order to perform wireless power transfer in the inductive coupling method, the wireless power transmitter 100 may be configured to include an interface surface (not shown) in the form of a flat surface. One or more electronic devices may be placed at an upper portion of the interface surface, and the transmitting coil 1111a may be mounted at a lower portion of the interface surface. In this case, a vertical spacing is formed in a small-scale between the transmitting coil 1111a mounted at a lower portion of the interface surface and the receiving coil 2911a of the electronic device 200 placed at an upper portion of the interface surface, and thus a distance between the coils becomes sufficiently small to efficiently implement contactless power transfer by the inductive coupling method.

[0104] Furthermore, an alignment indicator (not shown) indicating a location where the electronic device 200 is to be placed at an upper portion of the interface surface. The alignment indicator indicates a location of the electronic device 200 where an alignment between the transmitting coil 1111a mounted at a lower portion of the interface surface and the receiving coil 2911a can be suitably implemented. The alignment indicator may alternatively be simple marks, or may be formed in the form of a protrusion structure for guiding the location of the electronic device 200. Otherwise, the alignment indicator may be formed in the form of a magnetic body such as a magnet mounted at a lower portion of the interface surface, thereby guiding the coils to be suitably arranged by mutual magnetism to a magnetic body having an opposite polarity mounted within the electronic device 200.

[0105] On the other hand, the wireless power transmitter 100 may be formed to include one or more transmitting coils. The wireless power transmitter 100 may selectively use some of coils suitably arranged with the receiving coil 2911 a of the electronic device 200 among the one or more transmitting coils to enhance the power trans-

mission efficiency. The wireless power transmitter 100 including the one or more transmitting coils will be described later with reference to FIG. 5.

[0106] Hereinafter, a configuration of the wireless power transmitter and electronic device using an inductive coupling method applicable to the embodiments disclosed herein will be described in detail.

Wireless power transmitter and electronic device in inductive coupling method

[0107] FIG. 4 is an exemplary block diagram illustrating part of the wireless power transmitter 100 and electronic device 200 in a magnetic induction method that can be employed in the embodiments disclosed herein. A configuration of the power transmission unit 110 included in the wireless power transmitter 100 will be described with reference to FIG. 4A, and a configuration of the power supply unit 290 included in the electronic device 200 will be described with reference to FIG. 4B.

[0108] Referring to FIG. 4A, the power conversion unit 111 of the wireless power transmitter 100 may include a transmitting (Tx) coil 1111 a and an inverter 1112.

[0109] The transmitting coil 1111 a may form a magnetic field corresponding to the wireless power signal according to a change of current as described above. The transmitting coil 1111a may alternatively be implemented with a planar spiral type or cylindrical solenoid type.

[0110] The inverter 1112 transforms a DC input obtained from the power supply unit 190 into an AC waveform. The AC current transformed by the inverter 1112 drives a resonant circuit including the transmitting coil 1111a and a capacitor (not shown) to form a magnetic field in the transmitting coil 1111a.

[0111] In addition, the power conversion unit 111 may further include a positioning unit 1114.

[0112] The positioning unit 1114 may move or rotate the transmitting coil 1111a to enhance the effectiveness of contactless power transfer using the inductive coupling method. As described above, it is because an alignment and distance between the wireless power transmitter 100 and the electronic device 200 including a primary coil and a secondary coil may affect power transfer using the inductive coupling method. In particular, the positioning unit 1114 may be used when the electronic device 200 does not exist within an active area of the wireless power transmitter 100.

[0113] Accordingly, the positioning unit 1114 may include a drive unit (not shown) for moving the transmitting coil 1111a such that a center-to-center distance of the transmitting coil 1111a of the wireless power transmitter 100 and the receiving coil 2911 a of the electronic device 200 is within a predetermined range, or rotating the transmitting coil 1111a such that the centers of the transmitting coil 1111a and the receiving coil 2911 a are overlapped with each other.

[0114] For this purpose, the wireless power transmitter 100 may further include a detection unit (not shown)

made of a sensor for detecting the location of the electronic device 200, and the power transmission control unit 112 may control the positioning unit 1114 based on the location information of the electronic device 200 received from the location detection sensor.

[0115] Furthermore, to this end, the power transmission control unit 112 may receive control information on an alignment or distance to the electronic device 200 through the power communications modulation/demodulation unit 113, and control the positioning unit 1114 based on the received control information on the alignment or distance.

[0116] If the power conversion unit 111 is configured to include a plurality of transmitting coils, then the positioning unit 1114 may determine which one of the plurality of transmitting coils is to be used for power transmission. The configuration of the wireless power transmitter 100 including the plurality of transmitting coils will be described later with reference to FIG. 5.

[0117] On the other hand, the power conversion unit 111 may further include a power sensing unit 1115. The power sensing unit 1115 at the side of the wireless power transmitter 100 monitors a current or voltage flowing into the transmitting coil 1111a. The power sensing unit 1115 is provided to check whether or not the wireless power transmitter 100 is normally operated, and thus the power sensing unit 1115 may detect a voltage or current of the power supplied from the outside, and check whether the detected voltage or current exceeds a threshold value. The power sensing unit 1115, although not shown, may include a resistor for detecting a voltage or current of the power supplied from the outside and a comparator for comparing a voltage value or current value of the detected power with a threshold value to output the comparison result. Based on the check result of the power sensing unit 1115, the power transmission control unit 112 may control a switching unit (not shown) to cut off power applied to the transmitting coil 1111a.

[0118] Referring to FIG. 4B, the power supply unit 290 of the electronic device 200 may include a receiving (Rx) coil 2911a and a rectifier circuit 2913.

[0119] A current is induced into the receiving coil 2911a by a change of the magnetic field formed in the transmitting coil 1111a. The implementation type of the receiving coil 2911a may be a planar spiral type or cylindrical solenoid type similarly to the transmitting coil 1111a.

[0120] Furthermore, series and parallel capacitors may be configured to be connected to the receiving coil 2911a to enhance the effectiveness of wireless power reception or perform resonant detection.

[0121] The receiving coil 2911a may be in the form of a single coil or a plurality of coils.

[0122] The rectifier circuit 2913 performs a full-wave rectification to a current to convert alternating current into direct current. The rectifier circuit 2913, for instance, may be implemented with a full-bridge rectifier generation circuit made of four diodes or a circuit using active compo-

nents.

[0123] In addition, the rectifier circuit 2913 may further include a regulator circuit for converting a rectified current into a more flat and stable direct current. Furthermore, the output power of the rectifier circuit 2913 is supplied to each constituent element of the power supply unit 290. Furthermore, the rectifier circuit 2913 may further include a DC-DC converter for converting output DC power into a suitable voltage to adjust it to the power required for each constituent element (for instance, a circuit such as a charger 298).

[0124] The power communications modulation/demodulation unit 293 may be connected to the power receiving unit 291, and may be configured with a resistive element in which resistance varies with respect to direct current, and may be configured with a capacitive element in which reactance varies with respect to alternating current. The power receiving controller 292 may change the resistance or reactance of the power communications modulation/demodulation unit 293 to modulate a wireless power signal received to the power receiving unit 291.

[0125] On the other hand, the power supply unit 290 may further include a power sensing unit 2914. The power sensing unit 2914 at the side of the electronic device 200 monitors a voltage and/or current of the power rectified by the rectifier circuit 2913, and if the voltage and/or current of the rectified power exceeds a threshold value as a result of monitoring, then the power receiving controller 292 transmits a power control message to the wireless power transmitter 100 to transfer suitable power.

Wireless power transmitter configured to include one or more transmitting coils

[0126] FIG. 5 is a block diagram illustrating a wireless power transmitter configured to have one or more transmission coils receiving power according to an inductive coupling method that can be employed in the embodiments disclosed herein.

[0127] Referring to FIG. 5, the power conversion unit 111 of the wireless power transmitter 100 according to the embodiments disclosed herein may include one or more transmitting coils 1111a-1 to 1111a-n. The one or more transmitting coils 1111a-1 to 1111a-n may be an array of partly overlapping primary coils. An active area may be determined by some of the one or more transmitting coils.

[0128] The one or more transmitting coils 1111a-1 to 1111a-n may be mounted at a lower portion of the interface surface. Furthermore, the power conversion unit 111 may further include a multiplexer 1113 for establishing and releasing the connection of some of the one or more transmitting coils 1111a-1 to 1111a-n.

[0129] Upon detecting the location of the electronic device 200 placed at an upper portion of the interface surface, the power transmission control unit 112 may take the detected location of the electronic device 200 into consideration to control the multiplexer 1113, thereby al-

lowing coils that can be placed in an inductive coupling relation to the receiving coil 2911a of the electronic device 200 among the one or more transmitting coils 1111a-1 to 1111a-n to be connected to one another.

[0130] For this purpose, the power transmission control unit 112 may acquire the location information of the electronic device 200. For example, the power transmission control unit 112 may acquire the location of the electronic device 200 on the interface surface by the location detection unit (not shown) provided in the wireless power transmitter 100. For another example, the power transmission control unit 112 may alternatively receive a power control message indicating a strength of the wireless power signal from an object on the interface surface or a power control message indicating the identification information of the object using the one or more transmitting coils 1111a-1 to 1111a-n, respectively, and determines whether it is located adjacent to which one of the one or more transmitting coils based on the received result, thereby acquiring the location information of the electronic device 200.

[0131] On the other hand, the active area as part of the interface surface may denote a portion through which a magnetic field with a high efficiency can pass when the wireless power transmitter 100 transfers power to the electronic device 200 in a wireless manner. At this time, a single transmitting coil or one or a combination of more transmitting coils forming a magnetic field passing through the active area may be designated as a primary cell. Accordingly, the power transmission control unit 112 may determine an active area based on the detected location of the electronic device 200, and establish the connection of a primary cell corresponding to the active area to control the multiplexer 1113, thereby allowing the receiving coil 2911a of the electronic device 200 and the coils belonging to the primary cell to be placed in an inductive coupling relation.

[0132] In the meantime, upon disposing one or more electronic devices 200 on an interface surface of the wireless power transmitter 100, which includes the one or more transmitting coils 1111a-1 to 1111a-n, the power transmission control unit 112 may control the multiplexer 1113 to allow the coils belonging to the primary cell corresponding to the position of each electronic device to be placed in the inductive coupling relation. Accordingly, the wireless power transmitter 100 may generate the wireless power signal using different coils, thereby transferring it to the one or more electronic devices in a wireless manner.

[0133] Also, the power transmission control unit 112 may set power having a different characteristic to be supplied to each of the coils corresponding to the electronic devices. Here, the wireless power transmitter 100 may transfer power by differently setting a power transfer scheme, efficiency, characteristic and the like for each electronic device. The power transmission for one or more electronic devices will be described later with reference to FIG. 28.

[0134] Furthermore, the power conversion unit 111 may further include an impedance matching unit (not shown) for controlling an impedance to form a resonant circuit with the coils connected thereto.

[0135] A two-way communication using a wireless power signal disclosed herein may be typically carried out when the wireless power transmitter 100 transfers wireless power to the electronic device 200 through a resonance coupling method which will be described later, but according to circumstances, may be also applicable to a case of wireless power transmission by the inductive coupling method.

[0136] Hereinafter, a method for allowing a wireless power transmitter to transfer power according to a resonance coupling method will be disclosed with reference to FIGS. 6 through 8.

Resonance coupling method

[0137] FIG. 6 is a view illustrating a concept in which power is transferred to an electronic device from a wireless power transmitter in a wireless manner according to a resonance coupling method.

[0138] First, resonance will be described in brief as follows. Resonance refers to a phenomenon in which an amplitude of vibration is remarkably increased when periodically receiving an external force having the same frequency as the natural frequency of a vibration system. Resonance is a phenomenon occurring at all kinds of vibrations such as mechanical vibration, electric vibration, and the like. Generally, when exerting a vibratory force to a vibration system from the outside, if the natural frequency thereof is the same as a frequency of the externally applied force, then the vibration becomes strong, thus increasing the width.

[0139] With the same principle, when a plurality of vibrating bodies separated from one another within a predetermined distance vibrate at the same frequency, the plurality of vibrating bodies resonate with one another, and in this case, resulting in a reduced resistance between the plurality of vibrating bodies. In an electrical circuit, a resonant circuit can be made by using an inductor and a capacitor.

[0140] When the wireless power transmitter 100 transfers power according to the inductive coupling method, a magnetic field having a specific vibration frequency is formed by alternating current power in the power transmission unit 110. If a resonance phenomenon occurs in the electronic device 200 by the formed magnetic field, then power is generated by the resonance phenomenon in the electronic device 200.

[0141] Hereinafter, the principle of the resonance coupling method will be described.

[0142] However, if the plurality of vibrating bodies resonate with each other in an electromagnetic manner as aforementioned, extremely high power transmission efficiency may be exhibited due to non affection by adjacent objects except for the vibrating bodies. An energy tunnel

may be generated between the plurality of vibrating bodies which resonate with each other in the electromagnetic manner. This may be referred to as energy coupling or energy tail.

[0143] The resonance coupling disclosed herein may use an electromagnetic wave having a low frequency. When power is transferred using the electromagnetic wave having the low frequency, only a magnetic field may affect an area located within a single wavelength of the electromagnetic wave. The magnetic resonance may be generated when the wireless power transmitter 100 and the electronic device 200 are located within the single wavelength of the electromagnetic wave having the low frequency.

[0144] In this case, in general, human bodies are sensitive to an electric field but tolerant to a magnetic field. Hence, when power is transferred using a magnetic resonance, the human bodies may be badly affected due to being exposed to the electromagnetic wave. Also, as the energy tail is generated in response to the resonance phenomenon, the form of power transmission may exhibit a non-radiative property. Consequently, upon transferring power using such electromagnetic wave, a radiative problem which occurs frequently may be solved.

[0145] The resonance coupling method may be a method for transferring power using the electromagnetic wave with the low frequency, as aforementioned. Thus, the transmitting coil 1111 b of the wireless power transmitter 100 may form a magnetic field or electromagnetic wave for transferring power in principle. However, the resonance coupling method will be described hereinafter from the perspective of a magnetic resonance, namely, a power transmission by a magnetic field.

[0146] The resonant frequency may be determined by the following formula in Equation 1.

[Equation 1]

$$f = \frac{1}{2\pi\sqrt{LC}}$$

[0147] Here, the resonant frequency (f) is determined by an inductance (L) and a capacitance (C) in a circuit. In a circuit forming a magnetic field using a coil, the inductance can be determined by a number of turns of the coil, and the like, and the capacitance can be determined by a gap between the coils, an area, and the like. In addition to the coil, a capacitive resonant circuit may be configured to be connected thereto to determine the resonant frequency.

[0148] Referring to FIG. 6, when power is transmitted in a wireless manner according to the resonance coupling method, the power conversion unit 111 of the wireless power transmitter 100 may include a transmitting (Tx) coil 1111b in which a magnetic field is formed and a res-

onant circuit 1116 connected to the transmitting coil 1111b to determine a specific vibration frequency. The resonant circuit 1116 may be implemented by using a capacitive circuit (capacitors), and the specific vibration frequency may be determined based on an inductance of the transmitting coil 1111b and a capacitance of the resonant circuit 1116.

[0149] The configuration of a circuit element of the resonant circuit 1116 may be implemented in various forms such that the power conversion unit 111 forms a magnetic field, and is not limited to a form of being connected in parallel to the transmitting coil 1111 b as illustrated in FIG. 6.

[0150] Furthermore, the power receiving unit 291 of the electronic device 200 may include a resonant circuit 2912 and a receiving (Rx) coil 2911 b to generate a resonance phenomenon by a magnetic field formed in the wireless power transmitter 100. In other words, the resonant circuit 2912 may be also implemented by using a capacitive circuit, and the resonant circuit 2912 is configured such that a resonant frequency determined based on an inductance of the receiving coil 2911 b and a capacitance of the resonant circuit 2912 has the same frequency as a resonant frequency of the formed magnetic field.

[0151] The configuration of a circuit element of the resonant circuit 2912 may be implemented in various forms such that the power receiving unit 291 generates resonance by a magnetic field, and is not limited to a form of being connected in series to the receiving coil 2911 b as illustrated in FIG. 6.

[0152] The specific vibration frequency in the wireless power transmitter 100 may have LTx, CTx, and may be acquired by using the Equation 1. Here, the electronic device 200 generates resonance when a result of substituting the LRx and CRx of the electronic device 200 to the Equation 1 is same as the specific vibration frequency.

[0153] According to a contactless power transfer method by resonance coupling, when the wireless power transmitter 100 and electronic device 200 resonate at the same frequency, respectively, an electromagnetic wave is propagated through a short-range magnetic field, and thus there exists no energy transfer between the devices if they have different frequencies.

[0154] As a result, an efficiency of contactless power transfer by the resonance coupling method is greatly affected by a frequency characteristic, whereas the effect of an alignment and distance between the wireless power transmitter 100 and the electronic device 200 including each coil is relatively smaller than the inductive coupling method.

[0155] Hereinafter, the configuration of a wireless power transmitter and an electronic device in the resonance coupling method applicable to the embodiments disclosed herein will be described in detail.

Wireless power transmitter in resonance coupling method

[0156] FIG. 7 is a block diagram illustrating part of the configuration of the wireless power transmitter 100 and electronic device 200 in a resonance method that can be employed in the embodiments disclosed herein.

[0157] A configuration of the power transmission unit 110 included in the wireless power transmitter 100 will be described with reference to FIG. 7A.

[0158] The power conversion unit 111 of the wireless power transmitter 100 may include a transmitting (Tx) coil 1111b, an inverter 1112, and a resonant circuit 1116. The inverter 1112 may be configured to be connected to the transmitting coil 1111b and the resonant circuit 1116.

[0159] The transmitting coil 1111b may be mounted separately from the transmitting coil 1111a for transferring power according to the inductive coupling method, but may transfer power in the inductive coupling method and resonance coupling method using one single coil.

[0160] The transmitting coil 1111 b, as described above, forms a magnetic field for transferring power. The transmitting coil 1111 b and the resonant circuit 1116 generate resonance when alternating current power is applied thereto, and at this time, a vibration frequency may be determined based on an inductance of the transmitting coil 1111b and a capacitance of the resonant circuit 1116.

[0161] For this purpose, the inverter 1112 transforms a DC input obtained from the power supply unit 190 into an AC waveform, and the transformed AC current is applied to the transmitting coil 1111 b and the resonant circuit 1116.

[0162] In addition, the power conversion unit 111 may further include a frequency adjustment unit 1117 for changing a resonant frequency of the power conversion unit 111. The resonant frequency of the power conversion unit 111 is determined based on an inductance and/or capacitance within a circuit constituting the power conversion unit 111 by Equation 1, and thus the power transmission control unit 112 may determine the resonant frequency of the power conversion unit 111 by controlling the frequency adjustment unit 1117 to change the inductance and/or capacitance.

[0163] According to some embodiments, the frequency adjustment unit 1117, for example, may be configured to include a motor for adjusting a distance between capacitors included in the resonant circuit 1116 to change a capacitance, or include a motor for adjusting a number of turns or diameter of the transmitting coil 1111b to change an inductance, or include active elements for determining the capacitance and/or inductance

[0164] On the other hand, the power conversion unit 111 may further include a power sensing unit 1115. The operation of the power sensing unit 1115 is the same as the foregoing description.

[0165] Referring to FIG. 7B, a configuration of the power supply unit 290 included in the electronic device 200

will be described. The power supply unit 290, as described above, may include the receiving (Rx) coil 2911b and resonant circuit 2912.

[0166] In addition, the power receiving unit 291 of the power supply unit 290 may further include a rectifier circuit 2913 for converting an AC current generated by resonance phenomenon into DC. The rectifier circuit 2913 may be configured similarly to the foregoing description.

[0167] Furthermore, the power receiving unit 291 may further include a power sensing unit 2914 for monitoring a voltage and/or current of the rectified power. The power sensing unit 2914 may be configured similarly to the foregoing description.

Wireless power transmitter configured to include one or more transmitting coils

[0168] FIG. 8 is a block diagram illustrating a wireless power transmitter configured to have one or more transmission coils receiving power according to a resonance coupling method that can be employed in the embodiments disclosed herein.

[0169] Referring to FIG. 8, the power conversion unit 111 of the wireless power transmitter 100 according to the embodiments disclosed herein may include one or more transmitting coils 1111b-1 to 1111b-n and resonant circuits (1116-1 to 1116-n) connected to each transmitting coils. Furthermore, the power conversion unit 111 may further include a multiplexer 1113 for establishing and releasing the connection of some of the one or more transmitting coils 1111 b-1 to 1111 b-n.

[0170] The one or more transmitting coils 1111b-1 to 1111b-n may be configured to have the same vibration frequency, or some of them may be configured to have different vibration frequencies. It is determined by an inductance and/or capacitance of the resonant circuits (1116-1 to 1116-n) connected to the one or more transmitting coils 1111b-1 to 1111b-n, respectively.

[0171] In the meantime, when one or more electronic devices 200 are disposed in an active area or a detection area of the wireless power transmitter 100 including the one or more transmitting coils 1111b-1 to 1111 b-n, the power transmission control unit 112 may control the multiplexer 1113 to allow the electronic devices to be placed in different resonance coupling relations. Accordingly, the wireless power transmitter 100 may wirelessly transfer power to the one or more electronic devices by generating the wireless power signal using different coils.

[0172] In addition, the power transmission control unit 112 may set power with a different characteristic to be supplied to each of the coils corresponding to the electronic devices. Here, the wireless power transmitter 100 may transfer power by differently setting a power transmission scheme, a resonant frequency, efficiency, a characteristic and the like for each electronic device. The power transmission for one or more electronic devices will be described later with reference to FIG. 28.

[0173] For this purpose, the frequency adjustment unit

1117 may be configured to change an inductance and/or capacitance of the resonant circuits (1116-1 to 1116-n) connected to the one or more transmitting coils 1111 b-1 to 1111 b-n, respectively.

Wireless power transmitter implemented by charger

[0174] On the other hand, hereinafter, an example of the wireless power transmitter implemented in the form of a wireless charger will be described.

[0175] FIG. 9 is a block diagram illustrating a wireless power transmitter further including an additional element in addition to the configuration illustrated in FIG. 2A.

[0176] Referring to FIG. 9, the wireless power transmitter 100 may further include a sensor unit 120, a communication unit 130, an output unit 140, a memory 150, and a controller 180 in addition to the power transmission unit 110 and power supply unit 190 for supporting at least one of the foregoing inductive coupling method and resonance coupling method.

[0177] The controller 180 controls the power transmission unit 110, the sensor unit 120, the communication unit 130, the output unit 140, the memory 150, and the power supply unit 190.

[0178] The controller 180 may be implemented by a module separated from the power transmission control unit 112 in the power transmission unit 110 described with reference to FIG. 2 or may be implemented by a single module.

[0179] The sensor unit 120 may include a sensor for detecting the location of the electronic device 200. The location information detected by the sensor unit 120 may be used for allowing the power transmission unit 110 to transfer power in an efficient manner.

[0180] For instance, in case of wireless power transfer according to the inductive coupling method, the sensor unit 120 may be operated as a detection unit, and the location information detected by the sensor unit 120 may be used to move or rotate the transmitting coil 1111a in the power transmission unit 110.

[0181] Furthermore, for example, the wireless power transmitter 100 configured to include the foregoing one or more transmitting coils may determine coils that can be placed in an inductive coupling relation or resonance coupling relation to the receiving coil of the electronic device 200 among the one or more transmitting coils based on the location information of the electronic device 200.

[0182] On the other hand, the sensor unit 120 may be configured to monitor whether or not the electronic device 200 approaches a chargeable region. The approach or non-approach detection function of the sensor unit 120 may be carried out separately from the function of allowing the power transmission control unit 112 in the power transmission unit 110 to detect the approach or non-approach of the electronic device 200.

[0183] The communication unit 130 performs wired or wireless data communication with the electronic device

200. The communication unit 130 may include an electronic component for at least any one of Bluetooth™, Zigbee, Ultra Wide Band (UWB), Wireless USB, Near Field Communication (NFC), and Wireless LAN.

[0184] The output unit 140 may include at least one of a display unit 141 and an audio output unit (or SOUND OUTPUT UNIT) 142. The display unit 141 may include at least one of a liquid crystal display (LCD), a thin film transistor-liquid crystal display (TFT-LCD), an organic light-emitting diode (OLED), a flexible display, and a three-dimensional (3D) display. The display unit 141 may display a charging state under the control of the controller 180.

[0185] The memory 150 may include at least one storage medium of a flash memory type, a hard disk type, a multimedia card micro type, a card type memory (e.g., SD or XD memory), a random access memory (RAM), a static random access memory (SRAM), a read-only memory (ROM), an electrically erasable programmable read-only memory (EEPROM), a programmable read-only memory (PROM), a magnetic memory, a magnetic disk, an optical disk, and the like. The wireless power transmitter 100 may operate in association with a web storage performing the storage function of the memory 150 on the Internet. A program or commands performing the foregoing functions of the wireless power transmitter 100 may be stored in the memory 150. The controller 180 may perform the program or commands stored in the memory 150 to transmit power in a wireless manner. A memory controller (not shown) may be used to allow other constituent elements (e.g., controller 180) included in the wireless power transmitter 100 to access the memory 150.

[0186] However, it would be easily understood by those skilled in the art that the configuration of a wireless power transmitter according to the embodiment disclosed herein may be applicable to an apparatus, such as a docking station, a terminal cradle device, and an electronic device, and the like, excluding a case where it is applicable to only a wireless charger.

Wireless power receiver implemented with mobile terminal

[0187] FIG. 10 is view illustrating a configuration in case where an electronic device 200 according to the embodiments disclosed herein is implemented in the form of a mobile terminal.

[0188] The mobile communication terminal 200 may include a power supply unit 290 illustrated in FIG. 2B, 4B, or 7B.

[0189] Furthermore, the terminal 200 may further include a wireless communication unit 210, an Audio/Video (A/V) input unit 220, a user input unit 230, a sensing unit 240, an output unit 250, a memory 260, an interface unit 270, and a controller 280. FIG. 10 illustrates the terminal 100 having various components, but it is understood that implementing all of the illustrated components is not a

requirement. Greater or fewer components may alternatively be implemented.

[0190] Hereinafter, each component is described in sequence.

[0191] The wireless communication unit 210 may typically include one or more modules which permit wireless communications between the terminal 200 and a wireless communication system or between the terminal 200 and a network within which the terminal 200 is located. For example, the wireless communication unit 210 may include a broadcast receiving module 211, a mobile communication module 212, a wireless internet module 213, a short-range communication module 214, a location information module 215 and the like.

[0192] The broadcast receiving module 211 receives a broadcast signal and/or broadcast associated information from an external broadcast managing entity via a broadcast channel.

[0193] The broadcast channel may include a satellite channel and a terrestrial channel. The broadcast center may indicate a server which generates and transmits a broadcast signal and/or broadcast associated information or a server which receives a pre-generated broadcast signal and/or broadcast associated information and sends them to the portable terminal. The broadcast signal may be implemented as a TV broadcast signal, a radio broadcast signal, and a data broadcast signal, among others. The broadcast signal may further include a data broadcast signal combined with a TV or radio broadcast signal.

[0194] Examples of broadcast associated information may denote information associated with a broadcast channel, a broadcast program, a broadcast service provider, and the like. The broadcast associated information may be provided via a mobile communication network. In this case, it may be received by the mobile communication module 212.

[0195] The broadcast associated information may be implemented in various formats. For instance, broadcast associated information may include Electronic Program Guide (EPG) of Digital Multimedia Broadcasting (DMB), Electronic Service Guide (ESG) of Digital Video Broadcast-Handheld (DVB-H), and the like.

[0196] The broadcast receiving module 211 may be configured to receive digital broadcast signals transmitted from various types of broadcast systems. Such broadcast systems may include Digital Multimedia Broadcasting-Terrestrial (DMB-T), Digital Multimedia Broadcasting-Satellite (DMB-S), Media Forward Link Only (MediaFLO), Digital Video Broadcast-Handheld (DVB-H), Integrated Services Digital Broadcast-Terrestrial (ISDB-T) and the like. The broadcast receiving module 211 may be configured to be suitable for every broadcast system transmitting broadcast signals as well as the digital broadcasting systems.

[0197] Broadcast signals and/or broadcast associated information received via the broadcast receiving module 211 may be stored in a suitable device, such as a memory

260.

[0198] The mobile communication module 212 transmits/receives wireless signals to/from at least any one of a base station, an external portable terminal, and a server on a mobile communication network. The wireless signal may include audio call signal, video (telephony) call signal, or various formats of data according to transmission/reception of text/multimedia messages.

[0199] The wireless internet module 213 supports wireless Internet access for the mobile terminal 200. This module may be internally or externally coupled to the terminal 100. Examples of such wireless Internet access may include Wireless LAN (WLAN) (Wi-Fi), Wireless Broadband (Wibro), Worldwide Interoperability for Microwave Access (Wimax), High Speed Downlink Packet Access (HSDPA) and the like.

[0200] The short-range communication module 214 denotes a module for short-range communications. Suitable technologies for implementing this module may include Bluetooth, Radio Frequency Identification (RFID), Infrared Data Association (IrDA), Ultra-WideBand (UWB), ZigBee, and the like. On the other hand, Universal Serial Bus (USB), IEEE 1394, Thunderbolt of Intel technology, and the like, may be used for wired short-range communication.

[0201] The wireless internet module 213 or the short-range communication module 214 may establish data communication connection to the wireless power transmitter 100.

[0202] Through the established data communication, when there is an audio signal to be outputted while transferring power in a wireless manner, the wireless internet module 213 or the short-range communication module 214 may transmit the audio signal to the wireless power transmitter 100 through the short-range communication module. Furthermore, through the established data communication, when there is information to be displayed, the wireless internet module 213 or the short-range communication module 214 may transmit the information to the wireless power transmitter 100. Otherwise, the wireless internet module 213 or the short-range communication module 214 may transmit an audio signal received through a microphone integrated in the wireless power transmitter 100. Furthermore, the wireless internet module 213 or the short-range communication module 214 may transmit the identification information (e.g., phone number or device name in case of a portable phone) of the mobile terminal 200 to the wireless power transmitter 100 through the established data communication.

[0203] The location information module 215 is a module for acquiring a position of the terminal. An example of the location information module 215 may include a Global Position System (GPS) module.

[0204] Referring to FIG. 10, the A/V input unit 220 is configured to provide audio or video signal input to the portable terminal. The A/V input unit 220 may include a camera 221 and a microphone 222. The camera 221 processes image frames of still or moving images ob-

tained by an image sensor in a video call mode or a capture more. The processed image frames may be displayed on the display unit 251.

[0205] The image frames processed by the camera 221 may be stored in the memory 260 or transmitted to the exterior via the wireless communication unit 210. Two or more cameras 221 may be provided therein according to the use environment.

[0206] The microphone 222 may receive an external audio signal by a microphone in a phone call mode, a recording mode, a voice recognition mode, or the like to process it into electrical audio data. The processed audio data is converted and outputted into a format transmittable to a mobile communication base station via the mobile communication module 212 in case of the phone call mode. The microphone 222 may include various noise removal algorithms to remove noises generated while receiving the external audio signal.

[0207] The user input unit 230 may generate input data to allow the user to control the operation of the terminal. The user input unit 230 may include a keypad, a dome switch, a touchpad (e.g., static pressure/capacitance), a jog wheel, a jog switch and the like.

[0208] The sensing unit 240 may include a proximity sensor 241, a pressure sensor 242, a motion sensor 243, and the like. The proximity sensor 241 detects an object approaching the mobile terminal 200, or the presence or absence of an object existing adjacent to the mobile terminal 200, and the like without any mechanical contact. The proximity sensor 241 may detect a proximity object using a change of the AC magnetic field or static magnetic field, a change rate of the electrostatic capacity, or the like. Two or more proximity sensors 241 may be provided according to the aspect of configuration.

[0209] The pressure sensor 242 may detect whether or not a pressure is applied to the mobile terminal 200, a size of the pressure, and the like. The pressure sensor 242 may be provided at a portion where the detection of a pressure is required in the mobile terminal 200 according to the use environment. When the pressure sensor 242 is provided in the display unit 251, it may be possible to identify a touch input through the display unit 251 and a pressure touch input by which a pressure larger than the touch input is applied according to a signal outputted from the pressure sensor 242. Furthermore, it may be possible to know a size of the pressure applied to the display unit 251 during the input of a pressure touch.

[0210] The motion sensor 243 detects the location or movement of the mobile terminal 200 using an acceleration sensor, a gyro sensor, and the like. The acceleration sensor used in the motion sensor 243 is an element for converting an acceleration change in any one direction into an electrical signal. Two or three axes are typically integrated into a package to constitute an acceleration sensor, and only one Z-axis may be required according to the use environment. Accordingly, when an acceleration sensor in the direction of X-axis or Y-axis should be used instead of the direction of Z-axis due to any reason,

the acceleration sensor may be erected and mounted on a main substrate using a separate piece substrate. Furthermore, the gyro sensor is a sensor for measuring an angular speed of the mobile terminal 200 in a rotational movement to detect a rotated angle with respect to each reference direction. For instance, the gyro sensor may detect each rotational angle, i.e., azimuth, pitch and roll, with reference to three directional axes.

[0211] The output unit 250 is provided to output visual, auditory, or tactile information. The output unit 250 may include a display unit 251, an audio output module 252, an alarm unit 253, a haptic module 254, and the like.

[0212] The display unit 251 may display (output) information processed in the terminal 200. For example, when the terminal is in a phone call mode, the display unit 251 will provide a User Interface (UI) or Graphic User Interface (GUI) associated with the call. When the terminal is in a video call mode or a capture mode, the display unit 251 may display images captured and/or received, UI, or GUI.

[0213] The display unit 251 may include at least one of a liquid crystal display (LCD), a thin film transistor-liquid crystal display (TFT-LCD), an organic light-emitting diode (OLED), a flexible display, a three-dimensional (3D) display, and the like.

[0214] Some of those displays may be configured as a transparent type or an light transmission type through which the outside is visible, which is referred to as a transparent display. A representative example of the transparent display may include a Transparent OLED (TOLED), or the like. The rear surface of the display unit 151 may also be implemented to be optically transparent. Under this configuration, the user can view an object positioned at a rear side of the terminal body through a region occupied by the display unit 251 of the terminal body.

[0215] The display unit 251 may be implemented in two or more in number according to a configured aspect of the terminal 200. For instance, a plurality of the display units 251 may be arranged on one surface to be spaced apart from or integrated with each other, or may be arranged on different surfaces.

[0216] Here, if the display unit 251 and a touch sensitive sensor (referred to as a touch sensor) have a layered structure therebetween, the display unit 251 may be used as an input device rather than an output device. The touch sensor may be implemented as a touch film, a touch sheet, a touch pad, and the like.

[0217] The touch sensor may be configured to convert changes of a pressure applied to a specific part of the display unit 251, or a capacitance occurring from a specific part of the display unit 251, into electric input signals. Also, the touch sensor may be configured to sense not only a touched position and a touched area, but also a touch pressure.

[0218] When touch inputs are sensed by the touch sensors, corresponding signals are sent to a touch controller. The touch controller processes the received signals, and then transmits corresponding data to the controller 280.

Accordingly, the controller 280 may sense which region of the display unit 151 has been touched.

[0219] The proximity sensor 241 may be arranged at an inner region of the terminal covered by the touch screen, or near the touch screen. The proximity sensor refers to a sensor to sense the presence or absence of an object approaching a surface to be sensed, or an object disposed near a surface to be sensed, using an electromagnetic field or infrared rays without a mechanical contact. The proximity sensor has a longer lifespan and a more enhanced utility than a contact sensor.

[0220] The proximity sensor may include a transmissive type photoelectric sensor, a direct reflective type photoelectric sensor, a mirror reflective type photoelectric sensor, a high-frequency oscillation proximity sensor, a capacitance type proximity sensor, a magnetic type proximity sensor, an infrared rays proximity sensor, and so on. When the touch screen is implemented as a capacitance type, proximity of a pointer to the touch screen is sensed by changes of an electromagnetic field. In this case, the touch screen (touch sensor) may be categorized into a proximity sensor.

[0221] Hereinafter, for the sake of brief explanation, a status that the pointer is positioned to be proximate onto the touch screen without contact will be referred to as a "proximity touch", whereas a status that the pointer substantially comes in contact with the touch screen will be referred to as a "contact touch". For the position corresponding to the proximity touch of the pointer on the touch screen, such position corresponds to a position where the pointer faces perpendicular to the touch screen upon the proximity touch of the pointer.

[0222] The proximity sensor senses proximity touch, and proximity touch patterns (e.g., distance, direction, speed, time, position, moving status, etc.). Information relating to the sensed proximity touch and the sensed proximity touch patterns may be output onto the touch screen.

[0223] The audio output module 252 may output audio data received from the wireless communication unit 210 or stored in the memory 260, in a call-receiving mode, a call-placing mode, a recording mode, a voice recognition mode, a broadcast reception mode, and so on. The audio output module 252 may output audio signals relating to functions performed in the terminal 200, e.g., sound alarming a call received or a message received, and so on. The audio output module 252 may include a receiver, a speaker, a buzzer, and so on.

[0224] The alarm 253 outputs signals notifying the occurrence of an event from the terminal 200. The event occurring from the terminal 100 may include call received, message received, key signal input, touch input, and so on. The alarm 253 may output not only video or audio signals, but also other types of signals such as signals notifying occurrence of events in a vibration manner. Since the video or audio signals can be output through the display unit 251 or the audio output unit 252, the display unit 251 and the audio output module 252

may be categorized into part of the alarm 253.

[0225] The haptic module 254 generates various tactile effects which a user can feel. A representative example of the tactile effects generated by the haptic module 254 includes vibration. Vibration generated by the haptic module 254 may have a controllable intensity, a controllable pattern, and so on. For instance, different vibration may be output in a synthesized manner or in a sequential manner.

[0226] The haptic module 254 may generate various tactile effects, including not only vibration, but also arrangement of pins vertically moving with respect to a skin being contacted, air injection force or air suction force through an injection hole or a suction hole, touch by a skin surface, presence or absence of contact with an electrode, effects by stimulus such as an electrostatic force, reproduction of cold or hot feeling using a heat absorbing device or a heat emitting device, and the like.

[0227] The haptic module 254 may be configured to transmit tactile effects through the user's direct contact, or the user's muscular sense using a finger or a hand. The haptic module 254 may be implemented in two or more in number according to the configuration of the terminal 200.

[0228] The memory 260 may store a program for the processing and control of the controller 280. Alternatively, the memory 260 may temporarily store input/output data (e.g., phonebook data, messages, still images, video and the like). Also, the memory 260 may store data related to various patterns of vibrations and audio output upon the touch input on the touch screen.

[0229] In some embodiments, software components including an operating system (not shown), a module performing a wireless communication unit 210 function, a module operating together with the user input unit 230, a module operating together with the A/V input unit 220, a module operating together with the output unit 250 may be stored in the memory 260. The operating system (e.g., LINUX, UNIX, OS X, WINDOWS, Chrome, Symbian, iOS, Android, VxWorks, or other embedded operating systems) may include various software components and/or drivers to control system tasks such as memory management, power management, and the like.

[0230] In addition, the memory 260 may store a setup program associated with contactless power transfer or wireless charging. The setup program may be implemented by the controller 280.

[0231] Furthermore, the memory 260 may store an application associated with contactless power transfer (or wireless charging) downloaded from an application providing server (for example, an app store). The wireless charging related application is a program for controlling wireless charging transmission, and thus the electronic device 200 may receive power from the wireless power transmitter 100 in a wireless manner or establish connection for data communication with the wireless power transmitter 100 through the relevant program.

[0232] The memory 260 may be implemented using

any type of suitable storage medium including a flash memory type, a hard disk type, a multimedia card micro type, a memory card type (e.g., SD or xD memory), a random access memory (RAM), a static random access memory (SRAM), a read-only memory (ROM), an electrically erasable programmable read-only memory (EEPROM), a programmable read-only memory (PROM), a magnetic memory, a magnetic disk, an optical disk, and the like. Also, the terminal 200 may be operated in association with a web storage performing the storage function of the memory 160 on the Internet.

[0233] The interface unit 270 may generally be implemented to interface the portable terminal with all external devices. The interface unit 270 may allow a data reception from an external device, a power delivery to each component in the terminal 200, or a data transmission from the terminal 200 to an external device. The interface unit 270 may include, for example, wired/wireless headset ports, external charger ports, wired/wireless data ports, memory card ports, ports for coupling devices having an identification module, audio input/output (I/O) ports, video input/output (I/O) ports, earphone ports, and the like.

[0234] The identification module may be configured as a chip for storing various information required to authenticate an authority to use the terminal 200, which may include a User Identity Module (UIM), a Subscriber Identity Module (SIM), and the like. Also, the device having the identification module (hereinafter, referred to as "identification device") may be implemented in a type of smart card. Hence, the identification device can be coupled to the terminal 200 via a port.

[0235] Also, the interface unit may serve as a path for power to be supplied from an external cradle to the terminal 200 when the terminal 100 is connected to the external cradle or as a path for transferring various command signals inputted from the cradle by a user to the terminal 200. Such various command signals or power inputted from the cradle may operate as signals for recognizing that the terminal 200 has accurately been mounted to the cradle.

[0236] The controller 280 typically controls the overall operations of the terminal 200. For example, the controller 280 performs the control and processing associated with telephony calls, data communications, video calls, and the like. The controller 280 may include a multimedia module 281 for multimedia playback. The multimedia module 281 may be implemented within the controller 280, or implemented separately from the controller 280.

[0237] The controller 280 can perform a pattern recognition processing so as to recognize a writing input or image drawing input carried out on the touch screen as a text or image.

[0238] The controller 280 performs wired or wireless charging according to the user input or internal input. Here, the internal input represents a signal for notifying that an induced current generated from a secondary coil within the terminal has been detected.

[0239] As described above, the power receiving controller 292 within the power supply unit 290 may be implemented to be included in the controller 280, and in the present disclosure, it should be understood that the controller 280 performs the operation by the power receiving controller 292.

[0240] The power supply unit 290 receives internal and external power under the control of the controller 280 to supply power required for the operation of each constituent element.

[0241] The power supply unit 290 is provided with a battery 299 for supplying power to each constituent element of the terminal 200, and the battery 299 may include a charger 298 for performing wired or wireless charging.

[0242] The present disclosure discloses a mobile terminal as an example of the apparatus for receiving power in a wireless manner, but it would be easily understood by those skilled in the art that the configuration according to the embodiment disclosed herein may be applicable to a stationary terminal, such as a digital TV, a desktop computer, and the like, excluding a case where it is applicable to only the mobile terminal.

[0243] FIG. 11 is a view illustrating a two-way communication concept using a wireless power signal between a wireless power transmitter and an electronic device according to the embodiments disclosed herein.

[0244] The wireless power transmitter 100 according to the embodiments disclosed herein may perform two-way communication with the electronic device 200 using a wireless power signal.

[0245] In other words, in order to transmit data to the electronic device 200, the wireless power transmitter 100 modulates a carrier signal to contain the data to form a wireless power signal based on the modulated carrier signal. The electronic device 200 may demodulate the formed wireless power signal to receive the data.

[0246] Furthermore, the electronic device 200 may modulate a wireless power signal formed by the wireless power transmitter 100 to transmit data. The wireless power transmitter 100 may demodulate the modulated wireless power signal to receive data transmitted from the electronic device 200.

[0247] Hereinafter, a method of allowing the wireless power transmitter 100 to perform two-way communication with the electronic device 200 will be described with reference to FIG. 11.

[0248] As described above, the wireless power transmitter 100 may include a power transmission unit 110. The power transmission unit 110 may include a power conversion unit 111, a power transmission controller 112 and a modulation/demodulation unit 113.

[0249] According to the embodiments disclosed herein, the power transmission controller 112 may generate a packet containing data for the electronic device 200. The data for the electronic device 200 may include an identifier of the electronic device 200 for receiving the data or an identifier of a group to which the electronic device 200 for receiving the data belongs. Otherwise, the

data for the electronic device 200 may include a message for requesting the electronic device 200 to transmit an identifier. The data for the electronic device 200 may include a class or service type of the electronic device 200 or an identifier of the group. Furthermore, the data for the electronic device 200 may include a message for controlling a wireless power signal transmitted to the electronic device 200. Specifically, the data for the electronic device 200 may include content for determining at least one or more characteristics among the frequency, voltage and current of the wireless power signal, and may further include content for performing the other control operations. In the above, an example of data for the electronic device 200 is illustrated, but the data may not be limited to this, and may include data required to identify or sense the electronic device 200 as well as control the wireless power signal when transferring wireless power from the wireless power transmitter 100 to the electronic device 200.

[0250] Furthermore, the modulation/demodulation unit 113 may modulate a carrier signal to contain the generated packet. The power conversion unit 111 may generate a wireless power signal 10a for power transmission based on the modulated carrier signal. Furthermore, the power transmission controller 112 may transmit the packet to the electronic device 200 through the modulated wireless power signal 10a.

[0251] According to the embodiments disclosed herein, the power transmission controller 112 may determine status information on the electronic device 200 according to whether or not a response packet for the data is received within an expiration period of time from the electronic device 200.

[0252] Furthermore, according to the embodiments disclosed herein, the power conversion unit 111 may receive a wireless power signal 10b modulated by the electronic device 200, and the modulation/demodulation unit 113 may demodulate the received wireless power signal 10b.

[0253] Furthermore, referring to FIG. 11, the electronic device 200 may include the power supply unit 290 as described above. The power supply unit 290 may include a power receiving unit 291, a power receiving controller 292 and a modulation/demodulation unit 293.

[0254] According to an embodiment disclosed herein, the power receiving controller 292 may receive a packet containing data for the electronic device 200 from the wireless power transmitter 100. Furthermore, the modulation/demodulation unit 293 may demodulate the packet to acquire data for the electronic device 200 from the packet.

[0255] Furthermore, according to an embodiment disclosed herein, the modulation/demodulation unit 293 may modulate the demodulated packet to form a response packet. Furthermore, the power receiving controller 292 may transmit the response packet to the wireless power transmitter 100.

[0256] Hereinafter, two-way communication using a

wireless power signal between the wireless power transmitter 100 and electronic device 200 will be described in more detail.

5 Packet transmission of electronic device

[0257] Hereinafter, a process of transmitting a packet from the electronic device 200 to the wireless power transmitter 100 will be described with reference to FIG. 12.

10 **[0258]** FIG. 12 is a conceptual view illustrating the process of allowing an electronic device to transmit a packet to a wireless power transmitter according to the embodiments disclosed herein.

15 **[0259]** The wireless power signal formed by the power conversion unit 111 forms a closed-loop within a magnetic field or electromagnetic field, and therefore, when the electronic device 200 modulates the wireless power signal while receiving the wireless power signal, the wireless power transmitter 100 may detect the modulated wireless power signal. The power communications modulation/demodulation unit 113 may demodulate the detected wireless power signal, and decodes the packet from the modulated wireless power signal.

20 **[0260]** Referring to FIG. 12, a modulation method used for communication between the wireless power transmitter 100 and the electronic device 200 may be amplitude modulation. As described above, the amplitude modulation method may be a backscatter modulation method in which the power communications modulation/demodulation unit 293 at the side of the electronic device 200 changes an amplitude of the wireless power signal 51 formed by the power conversion unit 111 and the power receiving controller 292 at the side of the wireless power transmitter 100 detects an amplitude of the modulated wireless power signal 52.

25 Modulation/demodulation of transmitting and receiving packet

40 **[0261]** FIG. 13 is a view illustrating a method of allowing the wireless power transmitter to display a data bit and byte constituting a packet containing a power control message.

45 **[0262]** FIG. 13A is a view illustrating a method of allowing the wireless power transmitter to modulate a packet containing a power control message.

[0263] Further referring to FIG. 13A, the power receiving controller 292 at the side of the electronic device 200 modulates the wireless power signal 10a received through the power receiving unit 291 by changing a load impedance within the power communications modulation/demodulation unit 293. The power receiving controller 292 modulates the wireless power signal 51 to include a packet including a power control message to be transmitted to the wireless power transmitter 100.

55 **[0264]** Then, the power transmission control unit 112 at the side of the wireless power transmitter 100 demod-

ulates the modulated wireless power signal 52 through an envelope detection process, and decodes the detected signal 53 into digital data 54. The demodulation process detects a current or voltage flowing into the power conversion unit 111 to be classified into two states, a HI phase and a LO phase, and acquires a packet to be transmitted by the electronic device 200 based on digital data classified according to the states.

[0265] Hereinafter, a process of allowing the wireless power transmitter 100 to acquire a power control message to be transmitted by the electronic device 200 from the demodulated digital data will be described.

[0266] Referring to FIG. 13B, the power transmission control unit 112 detects an encoded bit using a clock signal (CLK) from an envelope detected signal. The detected encoded bit is encoded according to a bit encoding method used in the modulation process at the side of the electronic device 200. According to some embodiments, the bit encoding method may be non-return to zero (NRZ). According to some embodiments, the bit encoding method may be bi-phase encoding.

[0267] For instance, according to some embodiments, the detected bit may be a differential bi-phase (DBP) encoded bit. According to the DBP encoding, the power receiving controller 292 at the side of the electronic device 200 is allowed to have two state transitions to encode data bit 1, and to have one state transition to encode data bit 0. In other words, data bit 1 may be encoded in such a manner that a transition between the HI state and LO state is generated at a rising edge and falling edge of the clock signal, and data bit 0 may be encoded in such a manner that a transition between the HI state and LO state is generated at a rising edge of the clock signal.

[0268] On the other hand, the power transmission control unit 112 may acquire data in a byte unit using a byte format constituting a packet from a bit string detected according to the bit encoding method. For instance, the detected bit string may be transferred by using an 11-bit asynchronous serial format as illustrated in FIG. 13C. In other words, the detected bit may include a start bit indicating the beginning of a byte and a stop bit indicating the end of a byte, and also include data bits (b0 to b7) between the start bit and the stop bit. Furthermore, it may further include a parity bit for checking an error of data. The data in a byte unit constitutes a packet including a power control message.

Structure of transmitting/receiving packet

[0269] Hereinafter, the structure of a packet used in two-way communication using a wireless power signal according to the embodiments disclosed herein will be described.

[0270] FIG. 14 is a view illustrating the structure of a packet used in two-way communication using a wireless power signal according to the embodiments disclosed herein. The packet structure described with reference to FIG. 14 may be used to transmit data from the wireless

power transmitter 100 to the electronic device 200 as will be described later as well as used to transmit data from the electronic device 200 to the wireless power transmitter 100 described with reference to FIG. 13.

[0271] FIG. 14A is a view illustrating the structure of a command packet used in two-way communication using a wireless power signal according to the embodiments disclosed herein.

[0272] Referring to FIG. 14A, the wireless power transmitter 100 and electronic device 200 may transmit and receive data desired to be transmitted in the form of a command packet. The command packet may include a header and a message.

[0273] The header may include a field indicating the kind of data contained in the message. The size and kind of the message may be determined based on a value shown by the field indicating the kind of data.

[0274] Furthermore, the header may include an address field capable of identifying the sender and recipient of the packet. For instance, the address field may indicate an identifier of the electronic device 200 for receiving the data or an identifier of a group to which the electronic device 200 for receiving the data belongs. When the electronic device 200 wants to transmit the packet, the electronic device 200 may generate the packet in such a manner that the address field of the packet indicates its own identification information. Furthermore, the wireless power transmitter 100 wants to transmit the packet, the wireless power transmitter 100 may generate the packet in such a manner that the address field of the packet indicates the identification information of an electronic device for receiving the packet or the identification information of a group to which the electronic device for receiving the packet belongs.

[0275] The message may include data to be transmitted by the sender of the packet. The data contained in the message may be a report, a request or a response for the counterpart.

[0276] FIG. 14B is a view illustrating the detailed configuration of a command packet used in two-way communication using a wireless power signal according to the embodiments disclosed herein.

[0277] On the other hand, according to some embodiments, the command packet may be configured as illustrated in FIG. 14B. The header contained in the command packet may be expressed as a predetermined size. For instance, the header may have a size of two bytes.

[0278] The header may include an address field. For instance, the address field may have a size of six bits.

[0279] The header may include an operation command field (OCF) and an operation group field (OGF). The OGF is a value given for each group of commands for the electronic device 200, and the OCF is a value given for each command existing in each group to which the electronic device 200 belongs.

[0280] The message may be expressed with a length field of the parameter and a value field of the parameter in a separate manner. In other words, the sender of the

packet may configure the message in the form of a length-value pair of one or more parameters required to express data desired to be transmitted.

[0281] Referring to FIG. 14C, the wireless power transmitter 100 and the electronic device 200 may transmit and receive the data in the form of a packet in which a preamble and a checksum for transmission are added to the command packet.

[0282] The preamble 510 may be used to perform synchronization with data received by the wireless power transmitter 100 and detect the start bit of the header 520. The preamble 510 may be configured to repeat the same bit. For instance, the preamble 510 may be configured such that data bit 1 according to the DBP encoding is repeated eleven to twenty five times.

[0283] The message 530 may include data determined based on the header 520. The message 530 has a predetermined sized according to the size thereof.

[0284] The checksum 540 may be used to detect an error that can be occurred in the header 520 and the message 530 while transmitting a power control message. The header 520 and the message 530 excluding the preamble 510 for synchronization and the checksum 540 for error checking may be referred to as command_packet.

[0285] FIG. 15 is a conceptual view illustrating the process of allowing a wireless power transmitter to transmit a packet to an electronic device according to the embodiments disclosed herein.

[0286] Referring to FIG. 15, the power conversion unit 111 may include an inverter 1112, and the inverter 1112 may transform a DC input obtained from the power supply unit 190 into an AC waveform 310.

[0287] The AC waveform 310 transformed by the inverter 1112 may drive a resonant circuit containing a transmitting coil 1111b and a capacitor (not shown), thereby forming a magnetic field in the transmitting coil 1111 b.

[0288] The modulation/demodulation unit 113 may mix the AC waveform 310 with a data signal for the electronic device 200 generated from the power transmission controller 112 for modulation.

[0289] The power conversion unit 111 generates a wireless power signal 320 for power transmission based on the carrier signal and the power transmission controller 112 transmits the wireless power signal 320 to the electronic device 200.

[0290] The power receiving controller 292 at the side of the electronic device 200 may change the wireless power signal with a load impedance within the modulation/demodulation unit 293 for modulation. The load impedance may include passive and active elements. For example, the passive element may be a resistor, and the active element may be a transistor. FIG. 15 illustrates a case where the electronic device 200 includes a resistor 341 and a transistor 351.

[0291] FIG. 16 is a conceptual view illustrating the process of allowing a wireless power transmitter to trans-

mit a packet to an electronic device based on the flow of time according to the embodiments disclosed herein.

[0292] Referring to FIG. 16, the wireless power transmitter 100 may determine status information on the electronic device 200 according to whether or not a response packet for the data is received within an expiration period of time from the electronic device 200.

[0293] Specifically, when the response packet is not received from the electronic device 200 within the expiration period of time, the wireless power transmitter 100 may determine the status information on the electronic device 200 as a removed state. Furthermore, when the response packet is received from the electronic device 200 within the expiration period of time, the wireless power transmitter 100 may determine the status information on the electronic device 200 as a normal state. The expiration period of time may have a predetermined length including a period of time for transmitting the wireless power signal and a period of time for receiving the response packet.

[0294] Referring to FIG. 16, the wireless power transmitter 100 sends a first wireless power signal 1100 to the electronic device 200. When the response packet 1200 is received within an expiration period of time from the electronic device 200, the wireless power transmitter 100 determines the status of the electronic device 200 as a normal state to continuously perform the transmission and reception of the wireless power signal.

[0295] Then, the wireless power transmitter 100 sends a second wireless power signal 1300 to the electronic device 200. When the response packet is not received within an expiration period of time from the electronic device 200, the wireless power transmitter 100 determines the status of the electronic device 200 as a removed state to suspend the transmission and reception of the wireless power signal.

[0296] Next, the wireless power transmitter 100 determines the status of the electronic device 200 through the same process for the electronic device 200 to determine whether or not to continuously perform the transmission and reception of the wireless power signal for the electronic device 200.

[0297] FIG. 17 is a view illustrating a two-way communication concept using a wireless power signal between a wireless power transmitter and one or electronic devices according to the embodiments disclosed herein.

[0298] In FIG. 17, the one or more electronic devices are illustrated as two devices, and the one or more electronic devices represent a first electronic device 200a and a second electronic device 200b.

[0299] Referring to FIG. 17, the wireless power transmitter 100 may include a power transmission unit 110 as illustrated in FIG. 11. The power transmission unit 110 may include a power conversion unit 111 and a power transmission controller 112.

[0300] Similarly to two-way communication between the wireless power transmitter and electronic device in FIG. 11, the power conversion unit 111 converts power

supplied from the power supply unit 190 at the transmission side thereof into a wireless power signal to transfer the wireless power signal, thereby transferring it to the first electronic device 200a and second electronic device 200b which are a plurality of electronic devices.

[0301] Furthermore, the wireless power transmitter 100 may transmit a wireless power signal containing data for the first electronic device 200a and second electronic device 200b to the first electronic device 200a and second electronic device 200b. The modulation/demodulation unit 293a and 293b demodulates the wireless power signal to transmit it to the first electronic device 200a and second electronic device 200b.

[0302] According to an embodiment disclosed herein, the packet may include a destination address to identify the one or more electronic devices. The destination address is information indicating an electronic device to which the packet is transmitted between the first electronic device 200a and second electronic device 200b. For example, the destination address is an identifier of the electronic device for receiving the data between the first electronic device 200a and second electronic device 200b or an identifier of the electronic device 200 for receiving the data or an identifier of a group to which the electronic device 200 for receiving the data belongs.

[0303] According to an embodiment disclosed herein, the wireless power transmitter 100 may receive a response signal from the one or more electronic device 200a and 200b as illustrated in FIG. 11. The response signal may include a source address for identifying an electronic device 200a or 200b to which the wireless power transmitter 100 has transmitted the response signal. The source address may be an identifier of the one or more electronic devices 200a and 200b or an identifier of a group to which the one or more electronic devices 200a and 200b for receiving the data belong.

[0304] Furthermore, the wireless power transmitter 100 may determine the status of the one or more electronic devices 200a and 200b according to whether or not the response signal is transmitted within an expiration period of time. For example, when the wireless power transmitter 100 transmits a wireless power signal to the first electronic device 200a and receives a response signal from the first electronic device 200a within an expiration period of time, the wireless power transmitter 100 determines that the first electronic device 200a is in a normal state to continuously perform communication with the first electronic device 200a. On the contrary, when the wireless power transmitter 100 does not receive a response signal from the first electronic device 200a within an expiration period of time, the wireless power transmitter 100 determines that the first electronic device 200a is in a removed state to suspend communication or transmit a wireless power signal to the second electronic device 200b. The expiration period of time may have a predetermined length including a period of time for transmitting the wireless power signal and a period of time for receiving a response packet from the first electronic de-

vice 200a or the second electronic device 200b.

[0305] Furthermore, the wireless power transmitter 100 may retransmit a wireless power signal for detecting the first electronic device 200a again subsequent to the expiration period of time to the first electronic device 200a determined as the removed state. Otherwise, the wireless power transmitter 100 may transmit a wireless power signal for detecting the first electronic device 200a again subsequent to terminating the detection process of the second electronic device 200b for receiving power from the wireless power transmitter 100.

[0306] The wireless power transmitter 100 may sequentially transmit a wireless power signal for the first electronic device 200a and second electronic device 200b to the first electronic device 200a and second electronic device 200b. Specifically, the wireless power transmitter 100 transmits the wireless power signal to the first electronic device 200a and waits for a response signal of the first electronic device 200a for a first expiration period of time to sense the status of the first electronic device 200a. Next, after the first expiration period of time has passed, the wireless power transmitter 100 transmits the wireless power signal to the second electronic device 200b, and waits for a response signal of the second electronic device 200b for a second expiration period of time to sense the status of the second electronic device 200b. The wireless power transmitter 100 sequentially repeats the foregoing process for one or more electronic devices to detect electronic devices 200, respectively, to perform data communication through the transmission and reception of the wireless power signal.

[0307] FIG. 18 is a conceptual view illustrating the process of allowing a wireless power transmitter to transmit a packet to one or more electronic devices based on the flow of time according to the embodiments disclosed herein.

[0308] Referring to FIG. 18, the wireless power transmitter 100 may determine status information on the one or more electronic devices 200 according to whether or not a response packet for the data is received within an expiration period of time from the one or more electronic devices 200. The foregoing determination is carried out as described with reference to FIG. 16, but sequentially carried out for the one or more electronic devices 200.

[0309] Specifically, when the response packet is not received from the one or more electronic devices 200 within the expiration period of time, the wireless power transmitter 100 may determine status information on the one or more electronic devices 200 as a removed state. Furthermore, when the response packet is received from the one or more electronic devices 200 within the expiration period of time, the wireless power transmitter 100 may determine status information on the electronic device 200 as a removed state. The expiration period of time may have a predetermined length including a period of time for transmitting the wireless power signal and a period of time for receiving the response packet.

[0310] Referring to FIG. 18, the wireless power trans-

mitter 100 sends a first wireless power signal 1101 to the first electronic device 200a. When the response packet 1201 is received within an expiration period of time from the first electronic device 200a, the wireless power transmitter 100 determines the status of the first electronic device 200a as a normal state to continuously perform the transmission and reception of the wireless power signal.

[0311] Then, the wireless power transmitter 100 sends a second wireless power signal 1301 to the second electronic device 200b. When a response packet is not received within an expiration period of time from the second electronic device 200b, the wireless power transmitter 100 determines the status of the second electronic device 200b as a removed state to suspend the transmission and reception of the wireless power signal.

[0312] Next, wireless power transmitter 100 may determine the status of the third electronic device through the same process for the third electronic device (not shown), and determine whether or not to continuously perform the transmission and reception of the wireless power signal for the third electronic device.

[0313] FIG. 19 is a flow chart illustrating the process of performing two-way communication using a wireless power signal between a wireless power transmitter and one or more electronic devices according to the embodiments disclosed herein.

[0314] Referring to FIG. 19A, the wireless power transmitter 100 generates a data packet for the first electronic device 200a (S2101). The power transmission controller 112 provided in the wireless power transmitter 100 generates a packet containing data for the first electronic device 200a.

[0315] Then, the wireless power transmitter 100 modulates a carrier signal to contain the packet (S2102). The modulation/demodulation unit 113 provided in the wireless power transmitter 100 mixes an AC current transformed by the inverter 1112 with a data signal for the first electronic device 200a generated from the power transmission controller 112 for modulation.

[0316] Next, the wireless power transmitter 100 forms a wireless power signal 350 based on the carrier signal (S2103). The power conversion unit 111 provided in the wireless power transmitter 100 forms a wireless power signal 350 based on a carrier signal modulated by the modulation/demodulation unit 113.

[0317] Then, the wireless power transmitter 100 transmits the wireless power signal 350 to the first electronic device 200a (S2104). The power transmission controller 112 provided in the wireless power transmitter 100 may use one or more wireless power transfer methods to transfer the wireless power signal 350 in a wireless manner to the first electronic device 200a without mutual contact. In other words, the wireless power transmitter 100 may transfer power using at least one of an inductive coupling method based on an electromagnetic induction phenomenon generated by the wireless power signal 350 and an electromagnetic resonance coupling method

based on an electromagnetic resonance phenomenon generated by a wireless power signal with a particular frequency.

[0318] Referring to FIG. 19B, the first electronic device 200a receives the wireless power signal 350 (S2111). The power receiving unit 291 a of the first electronic device 200a receives the wireless power signal 350 according to the wireless power transfer method of the wireless power transmitter 100. The power receiving unit 291 a may include constituent elements required for each method to receive the wireless power signal.

[0319] Next, the first electronic device 200a demodulates a packet contained in the wireless power signal 350 (S2112). The modulation/demodulation unit 293a of the first electronic device 200a is electrically connected to the power receiving unit 291 a to demodulate the wireless power signal 350 through an envelope detection process and decode the detected signal as digital data.

[0320] Then, the first electronic device 200a acquires data based on the packet (S2113). The power receiving controller 292a of the first electronic device 200a acquires data for the first electronic device 200a generated from the wireless power transmitter 100 based on the demodulated packet. The data may include a control message for controlling a destination address containing an identifier of the first electronic device 200a or a wireless power signal transferred to the first electronic device 200a.

[0321] Next, the first electronic device 200a compares the destination address contained in the data with the identifier of the first electronic device 200a (S2114). The power receiving controller 292a of the first electronic device 200a compares whether or not the digital data of the destination address obtained from the packet structure of the data is the same as the identifier of the first electronic device 200a or the identifier value of a group to which the first electronic device 200a belongs. It is to recognize whether the wireless power signal 350 is provided to identify the first electronic device 200a or control a wireless power signal transferred to the first electronic device 200a.

[0322] When the destination address contained in the data and the identifier of the first electronic device 200a are the same, the first electronic device 200a generates a response packet 360 corresponding to the data (S2115). When the data is transmitted to the first electronic device 200a to identify the first electronic device 200a or control a wireless power signal transmitted to the first electronic device 200a, the power receiving controller 292a of the first electronic device 200a generates a response signal corresponding to the data. The modulation/demodulation unit 293a of the first electronic device 200a modulates the response signal to form the response packet 360. The modulation/demodulation unit 293a may change a reactance of the modulation/demodulation unit 293a to perform a modulation process such that power energy received from the wireless power signal 350 is changed according to the changed reactance.

[0323] Next, the first electronic device 200a transmits the response packet 360 to the wireless power transmitter 100 (S2115). The power receiving controller 292a of the first electronic device 200a transmits the response packet 360 to the wireless power transmitter 100 according to a power transfer method of the wireless power transmitter 100. The power receiving controller 292a brings a change of the current and/or voltage of the power conversion unit 111 due to a change of the power energy of the modulated wireless power signal, thereby transmitting the response packet 360 to the wireless power transmitter 100 in such a manner that the wireless power transmitter 100 recognizes the response packet 360.

[0324] When the destination address contained in the data and the identifier of the first electronic device 200a are the same, the first electronic device 200a generates a response packet 360 corresponding to the data (S2115). When the data is transmitted to the first electronic device 200a to identify the first electronic device 200a or control a wireless power signal transmitted to the first electronic device 200a, the power receiving controller 292a of the first electronic device 200a generates a response signal corresponding to the data. The modulation/demodulation unit 293a of the first electronic device 200a modulates the response signal to form the response packet 360. The modulation/demodulation unit 293a may change a reactance of the modulation/demodulation unit 293a to perform a modulation process such that power energy received from the wireless power signal 350 is changed according to the changed reactance.

[0325] On the other hand, referring to FIG. 19A, the wireless power transmitter 100 receives or does not receive the modulated response packet 360 from the first electronic device 200a (S2105). The current and/or voltage of the power conversion unit 111 of the wireless power transmitter 100 is changed according to the response packet 360 modulated to change the power energy. In this manner, it may be possible to recognize whether the response packet 360 has been transmitted from the first electronic device 200a (S2105a) or has not been transmitted therefrom (S2105b) according to whether or not the change of the power energy of the power conversion unit 111 is sensed.

[0326] When the modulated wireless power signal is received from the first electronic device 200a, the wireless power transmitter 100 determines the status of the first electronic device 200a as a normal state (S2106a). The first electronic device 200a in a normal state may exist within a sensing region of the wireless power transmitter 100 to receive a wireless power signal in a normal manner from the wireless power transmitter 100.

[0327] Then, the wireless power transmitter 100 demodulates the wireless power signal (S2107). The modulation/demodulation unit 113 of the wireless power transmitter 100 senses a change of the current and/or voltage of the power conversion unit 111 to perform a demodulation process. Furthermore, the power transmission controller 112 may decode the packet based on

the demodulation process execution result, thereby acquiring data contained in the response packet 360.

[0328] Next, the wireless power transmitter 100 generates a data packet for the second electronic device 200b (S2108a). The power transmission controller 112 provided in the wireless power transmitter 100 generates a packet containing data for the second electronic device 200b, and repeatedly performs the process for receiving a response message from the second electronic device 200b.

[0329] When the modulated wireless power signal is not received from the first electronic device, the wireless power transmitter 100 determines the status of the first electronic device 200a as a removed state (S2106b). The first electronic device 200a in a removed state gets out of a sensing region of the wireless power transmitter 100, and thus there does not exist the first electronic device 200a, thereby allowing the wireless power transmitter 100 to suspend the transmission of a wireless power signal to the first electronic device 200a.

[0330] Then, the wireless power transmitter 100 generates a data packet for the second electronic device 200b (S2108b). Furthermore, the wireless power transmitter 100 repeatedly performs the process for receiving a response message from the second electronic device 200b.

Operation phases

[0331] Hereinafter, the operation phases of the wireless power transmitter 100 and the electronic device 200 will be described.

[0332] FIG. 20 is a view illustrating the operation phases of the wireless power transmitter and electronic device according to the embodiments disclosed herein.

[0333] Referring to FIG. 20, the operation phases of the wireless power transmitter 100 and the electronic device 200 for wireless power transfer may be divided into a selection phase (state) 610, a ping phase 620, an identification and configuration phase 630, and a power transfer phase 640.

[0334] The wireless power transmitter 100 detects whether or not objects exist within a range that the wireless power transmitter 100 can transmit power in a wireless manner in the selection state 610, and the wireless power transmitter 100 sends a detection signal to the detected object and the electronic device 200 sends a response to the detection signal in the ping state 620.

[0335] Furthermore, the wireless power transmitter 100 identifies the electronic device 200 selected through the previous states and acquires configuration information for power transmission in the identification and configuration state 630. The wireless power transmitter 100 transmits power to the electronic device 200 while controlling power transmitted in response to a control message received from the electronic device 200 in the power transfer state 640.

[0336] Hereinafter, each of the operation phases will

be described in detail.

1) Selection state

[0337] The wireless power transmitter 100 in the selection state 610 performs a detection process to select the electronic device 200 existing within a detection area. The detection area, as described above, refers to a region in which an object within the relevant area can affect on the characteristic of the power of the power conversion unit 111. Compared to the ping state 620, the detection process for selecting the electronic device 200 in the selection state 610 is a process of detecting a change of the power amount for forming a wireless power signal in the power conversion unit at the side of the wireless power transmitter 100 to check whether any object exists within a predetermined range, instead of the scheme of receiving a response from the electronic device 200 using a power control message. The detection process in the selection state 610 may be referred to as an analog ping process in the aspect of detecting an object using a wireless power signal without using a packet in a digital format in the ping state 620 which will be described later.

[0338] The wireless power transmitter 100 in the selection state 610 can detect that an object comes in or out within the detection area. Furthermore, the wireless power transmitter 100 can distinguish the electronic device 200 capable of transferring power in a wireless manner from other objects (for example, a key, a coin, etc.) among objects located within the detection area.

[0339] As described above, a distance that can transmit power in a wireless manner may be different according to the inductive coupling method and resonance coupling method, and thus the detection area for detecting an object in the selection state 610 may be different from one another.

[0340] First, in case where power is transmitted according to the inductive coupling method, the wireless power transmitter 100 in the selection state 610 can monitor an interface surface (not shown) to detect the alignment and removal of objects.

[0341] Furthermore, the wireless power transmitter 100 may detect the location of the electronic device 200 placed on an upper portion of the interface surface. As described above, the wireless power transmitter 100 formed to include one or more transmitting coils may perform the process of entering the ping state 620 in the selection state 610, and checking whether or not a response to the detection signal is transmitted from the object using each coil in the ping state 620 or subsequently entering the identification state 630 to check whether identification information is transmitted from the object. The wireless power transmitter 100 may determine a coil to be used for contactless power transfer based on the detected location of the electronic device 200 acquired through the foregoing process.

[0342] Furthermore, when power is transmitted according to the resonance coupling method, the wireless

power transmitter 100 in the selection state 610 can detect an object by detecting that any one of a frequency, a current and a voltage of the power conversion unit is changed due to an object located within the detection area.

[0343] On the other hand, the wireless power transmitter 100 in the selection state 610 may detect an object by at least any one of the detection methods using the inductive coupling method and resonance coupling method. The wireless power transmitter 100 may perform an object detection process according to each power transmission method, and subsequently select a method of detecting the object from the coupling methods for contactless power transfer to advance to other states 620, 630, 640.

[0344] On the other hand, for the wireless power transmitter 100, a wireless power signal formed to detect an object in the selection state 610 and a wireless power signal formed to perform digital detection, identification, configuration and power transmission in the subsequent states 620, 630, 640 may have a different characteristic in the frequency, strength, and the like. It is because the selection state 610 of the wireless power transmitter 100 corresponds to an idle state for detecting an object, thereby allowing the wireless power transmitter 100 to reduce consumption power in the idle state or generate a specialized signal for effectively detecting an object.

2) Ping state

[0345] The wireless power transmitter 100 in the ping state 620 performs a process of detecting the electronic device 200 existing within the detection area through a power control message. Compared to the detection process of the electronic device 200 using a characteristic of the wireless power signal and the like in the selection state 610, the detection process in the ping state 620 may be referred to as a digital ping process.

[0346] The detection signal formed to allowing the wireless power transmitter 100 in the ping state 620 to perform a digital detection process may be a wireless power signal formed by applying a power signal at a specific operating point for a predetermined period of time. The operating point may denote a frequency, duty cycle, and amplitude of the voltage applied to the transmitting (Tx) coil. The wireless power transmitter 100 may generate the detection signal generated by applying the power signal at a specific operating point for a predetermined period of time, and attempt to receive a power control message from the electronic device 200.

[0347] According to an embodiment disclosed herein, the wireless power transmitter 100 in the ping state 620 may transmit any packet containing data for the electronic device 200 to detect the electronic device 200.

[0348] On the other hand, the power control message corresponding to a response to the detection signal may be a message indicating a strength of the wireless power signal received by the electronic device 200. For exam-

ple, the electronic device 200 may transmit a signal strength packet 5100 including a message indicating the received strength of the wireless power signal. The strength of the power signal within the message 5130 may be a value indicating a degree of inductive coupling or resonance coupling for power transmission between the wireless power transmitter 100 and the electronic device 200.

[0349] The wireless power transmitter 100 may receive a response message to the detection signal to find the electronic device 200, and then extend the digital detection process to enter the identification and configuration state 630. In other words, the wireless power transmitter 100 maintains the power signal at a specific operating point subsequent to finding the electronic device 200 to receive a power control message required in the identification and configuration state 630.

[0350] However, if the wireless power transmitter 100 is not able to find the electronic device 200 to which power can be transferred, then the operation phase of the wireless power transmitter 100 will be returned to the selection state 610.

3) Identification and configuration state

[0351] The wireless power transmitter 100 in the identification and configuration state 630 may receive identification information and/or configuration information transmitted by the electronic device 200, thereby controlling power transmission to be effectively carried out.

[0352] The electronic device 200 in the identification and configuration state 630 may transmit a power control message including its own identification information. For this purpose, the electronic device 200, for instance, may transmit an identification packet 5200 including a message indicating the identification information of the electronic device 200. The message 5230 may include information (2531 and 5232) indicating a version of the contract for contactless power transfer, information 5233 for identifying a manufacturer of the electronic device 200, information 5234 indicating the presence or absence of an extended device identifier, and a basic device identifier 5235. Furthermore, if it is displayed that an extended device identifier exists in the information 5234 indicating the presence or absence of an extended device identifier, then an extended identification packet 5300 including the extended device identifier will be transmitted in a separate manner. When the extended device identifier is used as described above, information based on the manufacturer's identification information 5233, the basic device identifier 5235 and the extended device identifier 5330 will be used to identify the electronic device 200.

[0353] The electronic device 200 may transmit a power control message including information on expected maximum power in the identification and configuration state 630.

[0354] On the other hand, the wireless power transmitter 100 may generate a power transfer contract which is

used for power charging with the electronic device 200 based on the identification information and/or configuration information. The power transfer contract may include the limits of parameters determining a power transfer characteristic in the power transfer state 640.

[0355] The wireless power transmitter 100 may terminate the identification and configuration state 630 and return to the selection state 610 prior to entering the power transfer state 640. For instance, the wireless power transmitter 100 may terminate the identification and configuration state 630 to find another electronic device that can receive power in a wireless manner.

4) Power transfer state

[0356] The wireless power transmitter 100 in the power transfer state 640 transmits power to the electronic device 200.

[0357] The wireless power transmitter 100 may receive a power control message from the electronic device 200 while transferring power, and control a characteristic of the power applied to the transmitting coil in response to the received power control message. For example, the power control message used to control a characteristic of the power applied to the transmitting coil may be included in a control error packet 5500. The wireless power transmitter 100 may control the power applied to the transmitting coil according to the control error value. In other words, a current applied to the transmitting coil may be controlled so as to be maintained if the control error value is "0", reduced if the control error value is a negative value, and increased if the control error value is a positive value.

[0358] The wireless power transmitter 100 may monitor parameters within a power transfer contract generated based on the identification information and/or configuration information in the power transfer state 640. As a result of monitoring the parameters, if power transmission to the electronic device 200 violates the limits included in the power transfer contract, then the wireless power transmitter 100 may cancel the power transmission and return to the selection state 610.

[0359] The wireless power transmitter 100 may terminate the power transfer state 640 based on a power control message transferred from the electronic device 200.

[0360] According to some embodiments, if the charging of a battery has been completed while charging the battery using power transferred by the electronic device 200, then a power control message for requesting the suspension of wireless power transfer will be transferred to the wireless power transmitter 100. In this case, the wireless power transmitter 100 may receive a message for requesting the suspension of the power transmission, and then terminate wireless power transfer, and return to the selection state 610.

[0361] Furthermore, according to some embodiments, the electronic device 200 may transfer a power control message for requesting renegotiation or reconfiguration

to update the previously generated power transfer contract. The electronic device 200 may transfer a message for requesting the renegotiation of the power transfer contract when it is required a larger or smaller amount of power than the currently transmitted power amount. In this case, the wireless power transmitter 100 may receive a message for requesting the renegotiation of the power transfer contract, and then terminate contactless power transfer, and return to the identification and configuration state 630.

[0362] To this end, a message transmitted by the electronic device 200 may be an end power transfer packet 5600. The packet 5600 may include a header 5620 for notifying that it is an end power transfer packet and a message 5630 including an end power transfer code indicating the cause of the suspension. The end power transfer code may indicate any one of charge complete, internal fault, over temperature, over voltage, over current, battery failure, reconfigure, no response, and unknown error.

[0363] The foregoing method may be implemented in a recording medium readable by a computer or its similar devices by employing, for example, software, hardware or some combinations thereof.

[0364] For a hardware implementation, the embodiments described herein may be implemented by using at least any one of application specific integrated circuits (ASICs), digital signal processors (DSPs), digital signal processing devices (DSPDs), programmable logic devices (PLDs), field programmable gate arrays (FPGAs), processors, controllers, micro-controllers, microprocessors, other electronic units designed to perform the functions described herein. For example, the foregoing methods may be implemented by the control unit 180 or power transmission control unit 112 in the wireless power transmitter 100, or implemented by the controller 280 or power receiving control unit 292 in the electronic device 200.

[0365] For a software implementation, the embodiments such as procedures and functions disclosed herein may be implemented with separate software modules. Each of the software modules may perform one or more of the functions and operations described herein. Software codes may be implemented by using a software application written in a suitable programming language. The software codes may be stored in the memory 150 in the wireless power transmitter 100, and implemented by the control unit 180 or the power transmission control unit 112, and similarly, stored in the memory 260 in the electronic device 200, and implemented by the controller 280 or the power receiving control unit 292.

[0366] The scope of the invention will not be limited to the embodiments disclosed herein, and thus various modifications, variations, and improvements can be made in the present invention without departing from the spirit of the invention, and within the scope of the appended claims.

Claims

1. A wireless power transmitter, comprising
a power transmission controller configured to generate a packet containing data for one or more electronic devices;
a modulation/demodulation unit configured to modulate a carrier signal to contain the generated packet;
a power conversion unit configured to form a wireless power signal for power transmission based on the modulated carrier signal,
wherein the power transmission controller transmits the packet to the one or more electronic devices through the wireless power signal.
2. The wireless power transmitter of claim 1, wherein the power conversion unit receives a wireless power signal modulated by the one or more electronic devices, and
the modulation/demodulation unit demodulates the received wireless power signal.
3. The wireless power transmitter of claim 1, wherein the generated packet comprises a destination address, and the destination address indicates an electronic device for transmitting the data among the one or more electronic devices.
4. The wireless power transmitter of claim 3, wherein the destination address is an identifier of an electronic device for receiving the data or an identifier of a group to which one or more electronic devices for receiving the data belong.
5. The wireless power transmitter of claim 3, wherein the power transmission controller determines status information on the electronic device according to whether or not a response packet for the data is received within an expiration period of time from the electronic device corresponding to the destination address.
6. The wireless power transmitter of claim 5, wherein the power transmission controller determines the status information on the electronic device as a removed state when the response packet is not received from the electronic device corresponding to the destination address within the expiration period of time.
7. The wireless power transmitter of claim 5, wherein the power transmission controller determines the status information on the electronic device as a normal state when the response packet is received from the electronic device corresponding to the destination address within the expiration period of time.
8. The wireless power transmitter of claim 7, wherein

the power transmission controller generates packets containing the destination addresses of electronic devices, respectively, having the status information of a normal state, and sequentially transmits the generated packets to electronic devices corresponding to the packets, respectively.

- 9. An electronic device, comprising:
 - a power receiver configured to receive a wireless power signal from a wireless power transmitter;
 - a modulation/demodulation unit configured to demodulate a packet contained in the wireless power signal; and
 - a power receiving controller configured to acquire data based on the demodulated packet.
- 10. The electronic device of claim 9, wherein the power receiving controller transmits a response packet corresponding to the acquired data to the wireless power transmitter.
- 11. The electronic device of claim 10, wherein the packet comprises a destination address.
- 12. The electronic device of claim 11, wherein the power receiving controller determines whether or not to respond based on the destination address, and the determination of whether or not to respond determines whether the destination address indicates an identifier of the electronic device or an identifier of a group to which the electronic device belongs.
- 13. The electronic device of claim 12, wherein the power receiving controller transmits the response packet to the wireless power transmitter when a response is required as a result of the determination of whether or not to respond.
- 14. The electronic device of claim 10, wherein the modulation/demodulation unit modulates the received wireless power signal, and the response packet is modulated by the modulation/demodulation unit to be contained in the received wireless power signal for transmission.
- 15. The electronic device of claim 10, wherein the response packet is transmitted to the wireless power transmitter within an expiration period of time.
- 16. A wireless power transmission method, comprising:
 - forming a first wireless power signal for power transmission; and
 - transmitting the first wireless power signal to a first electronic device,
 - wherein the first wireless power signal is formed

5

10

15

20

25

30

35

40

45

50

55

based on a carrier signal modulated to contain a data packet generated for the first electronic device, and the packet is transmitted to the first electronic device through the first wireless power signal.

- 17. The wireless power transmission method of claim 16, wherein the packet comprises a destination address, wherein destination address is information indicating the first electronic device.
- 18. The wireless power transmission method of claim 17, wherein the destination address is an identifier of the first electronic device or an identifier of a group to which the first electronic device belongs.
- 19. The wireless power transmission method of claim 17, further comprising:
 - determining whether or not a response packet for the data has been received within an expiration period of time from the first electronic device.
- 20. The wireless power transmission method of claim 19, further comprising:
 - determining status information on the first electronic device as a removed state when the response packet is not received within the expiration period of time from the first electronic device.
- 21. The wireless power transmission method of claim 19, further comprising:
 - determining status information on the first electronic device as a normal state when the response packet is received within the expiration period of time from the first electronic device.
- 22. The wireless power transmission method of claim 21, further comprising:
 - modulating the response packet received from the first electronic device.
- 23. The wireless power transmission method of claim 16, further comprising:
 - forming a second wireless power signal for power transmission; and
 - transmitting the second wireless power signal to a second electronic device,
 - wherein the second wireless power signal is formed based on a carrier signal modulated to contain a data packet generated for the second electronic device, and the packet is transmitted

to the second electronic device through the second wireless power signal.

- 24.** A wireless power receiving method, comprising: 5
 receiving a wireless power signal from a wireless power transmitter;
 demodulating a packet contained in the wireless power signal; and 10
 acquiring data based on the demodulated packet.
 et.
- 25.** The wireless power receiving method of claim 24, further comprising: 15
 transmitting a response packet corresponding to the acquired data to the wireless power transmitter.
- 26.** The wireless power receiving method of claim 25, 20
 wherein the packet comprises a destination address.
- 27.** The wireless power receiving method of claim 26, further comprising: 25
 determining whether or not to respond based on the destination address,
 wherein the determination of whether or not to respond determines whether the destination address indicates an identifier of the electronic device or an identifier of a group to which the electronic device belongs. 30
- 28.** The wireless power receiving method of claim 27, wherein said transmitting a response packet transmits the response packet to the wireless power transmitter when a response is required as a result of the determination of whether or not to respond. 35
- 29.** The wireless power receiving method of claim 25, 40
 wherein said transmitting a response packet modulates the received wireless power signal, and the response packet is modulated to be contained in the received wireless power signal for transmission.
 45
- 30.** The wireless power receiving method of claim 25, wherein the response packet is transmitted to the wireless power transmitter within an expiration period of time. 50
 55

FIG. 1

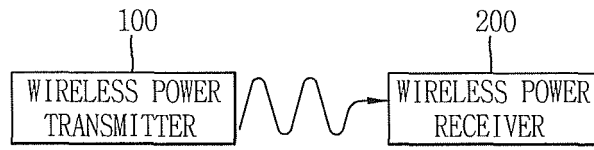

FIG. 2A

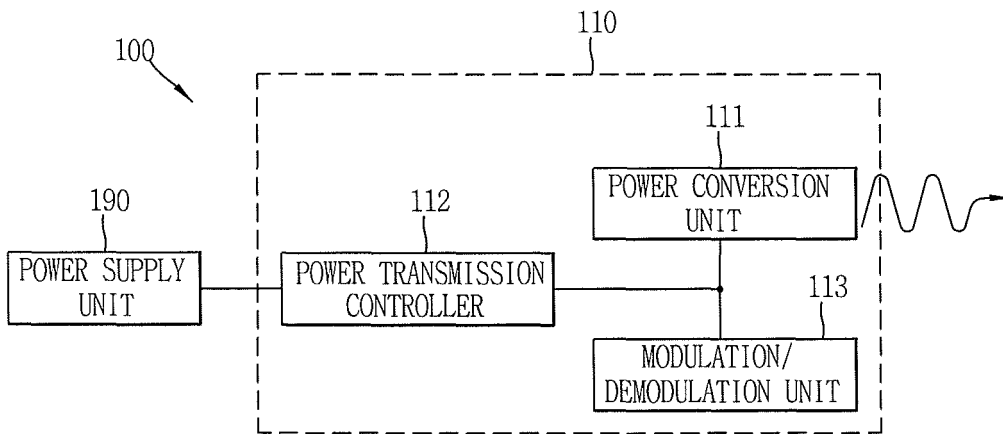

FIG. 2B

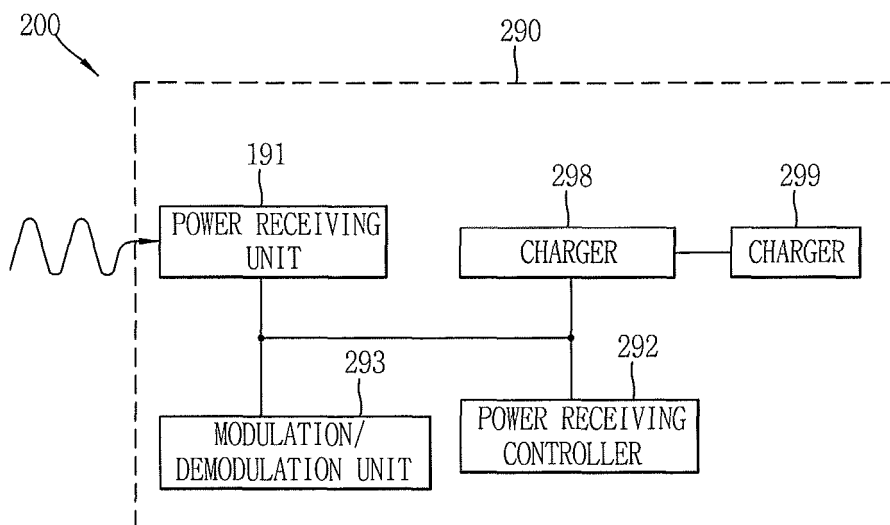

FIG. 3

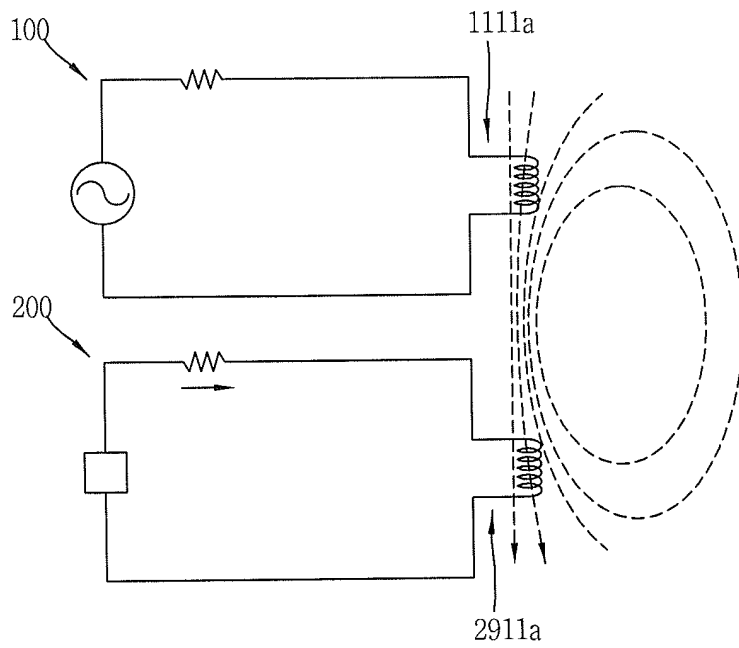

FIG. 4A

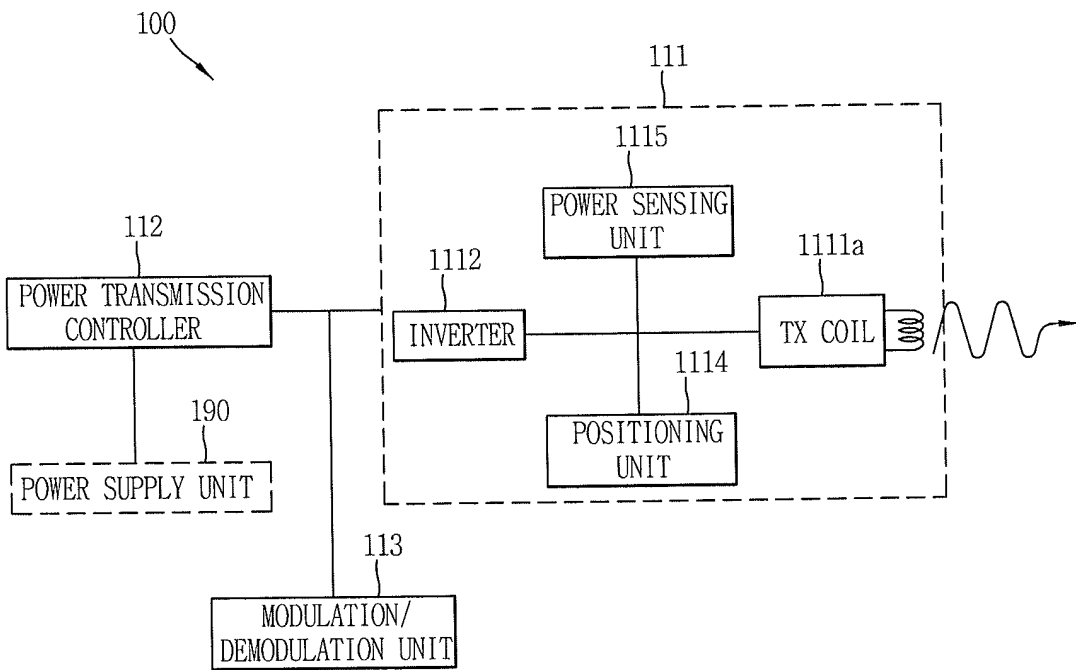

FIG. 4B

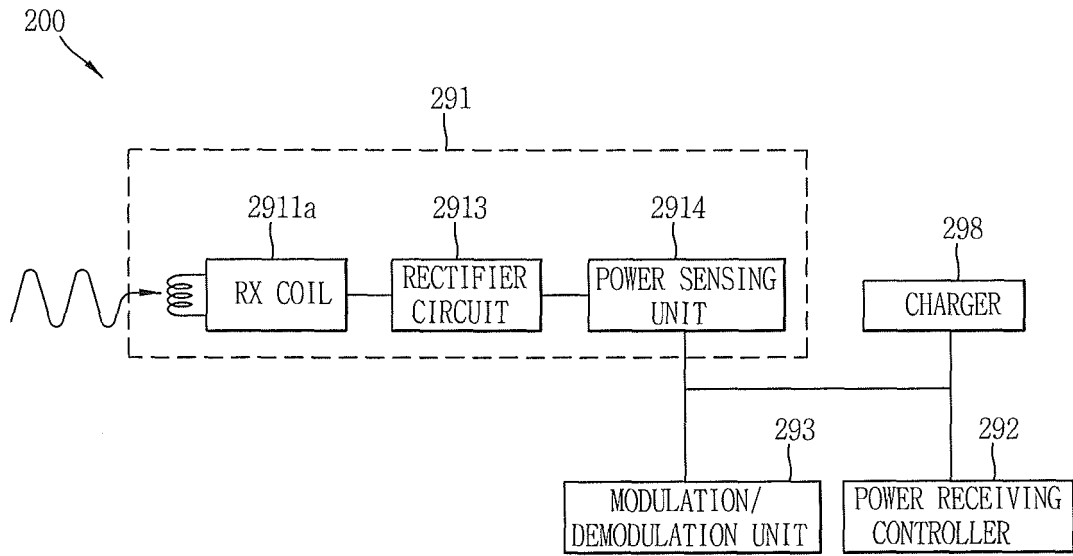

FIG. 5

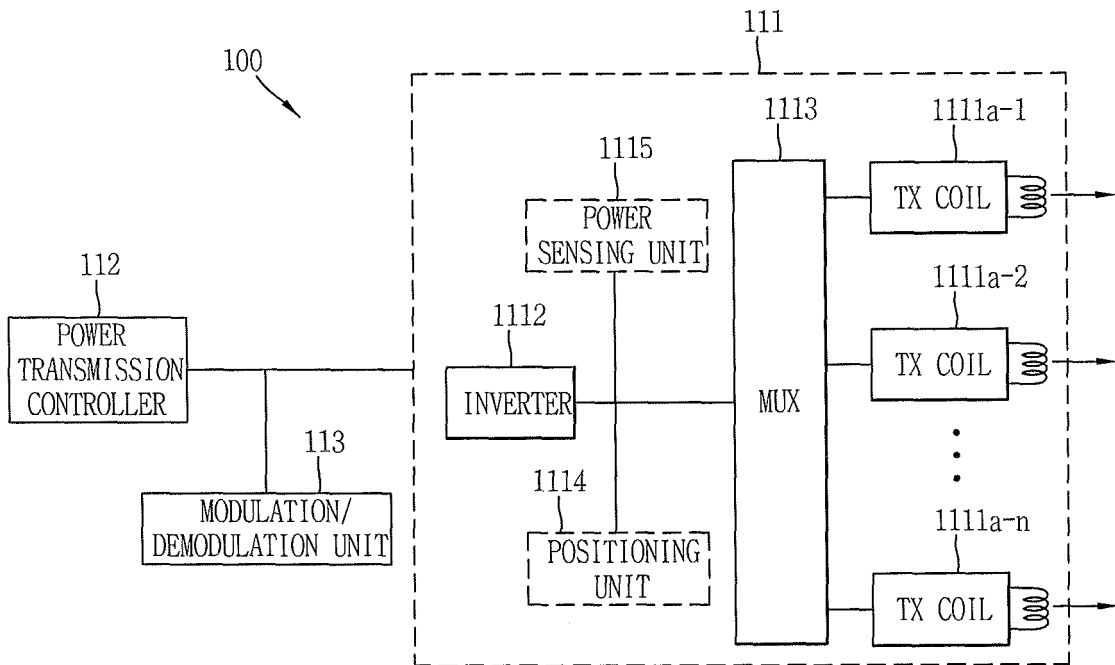

FIG. 6

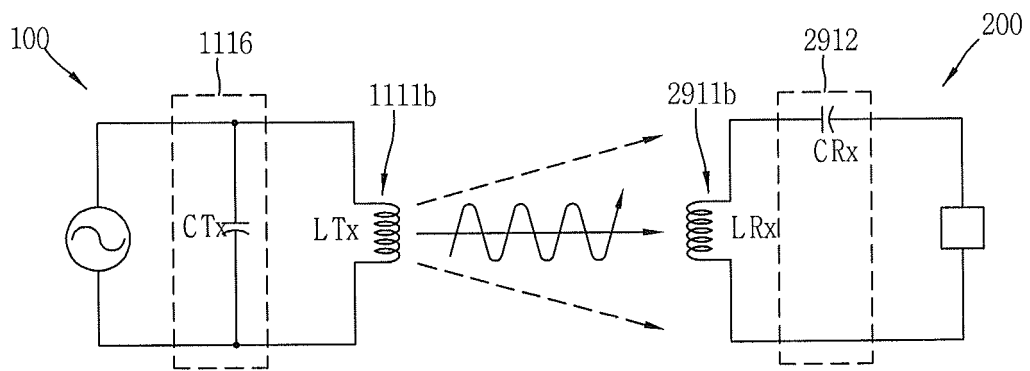

FIG. 7A

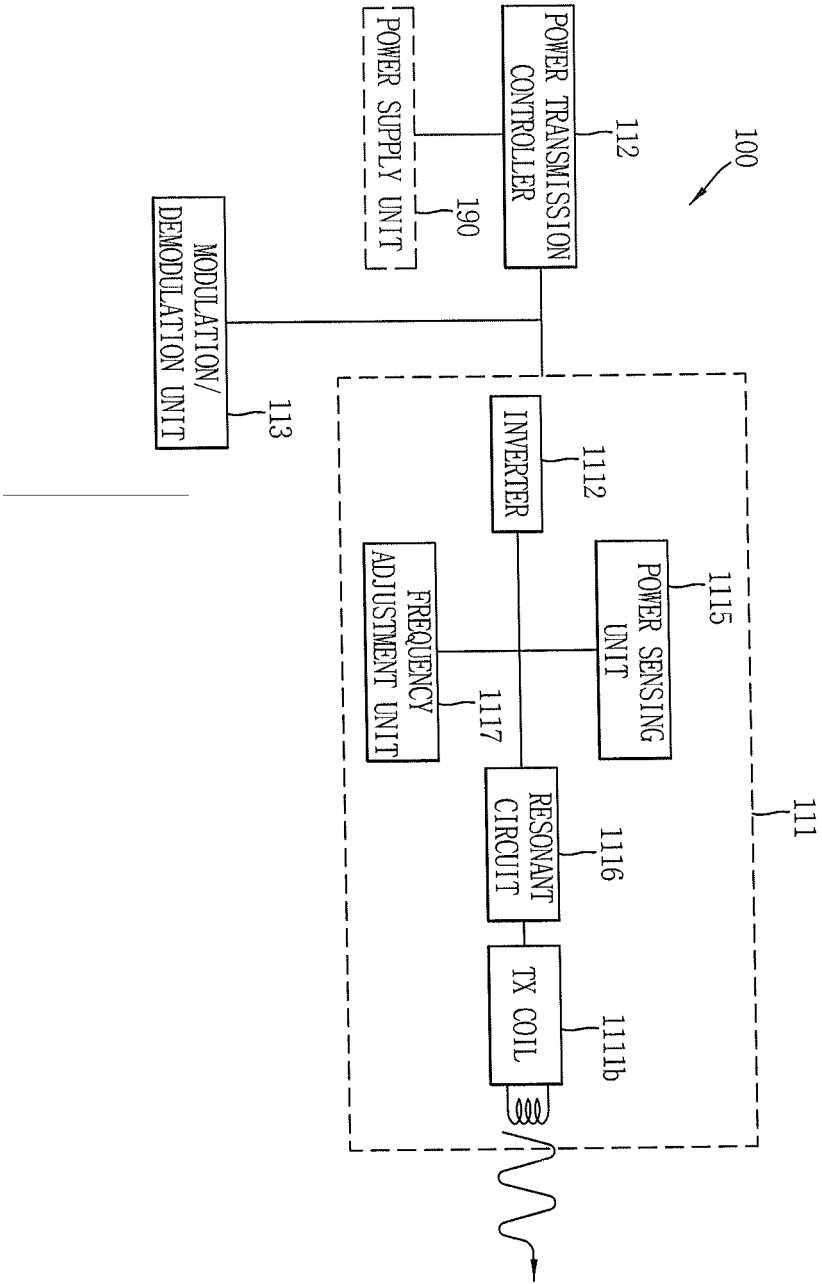

FIG. 7B

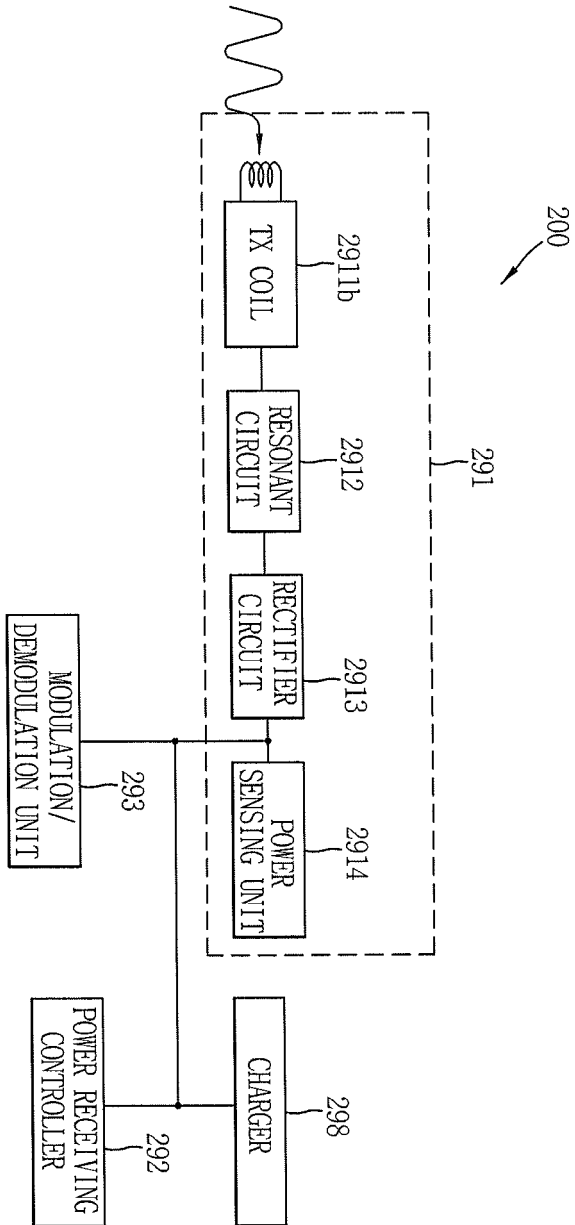

FIG. 8

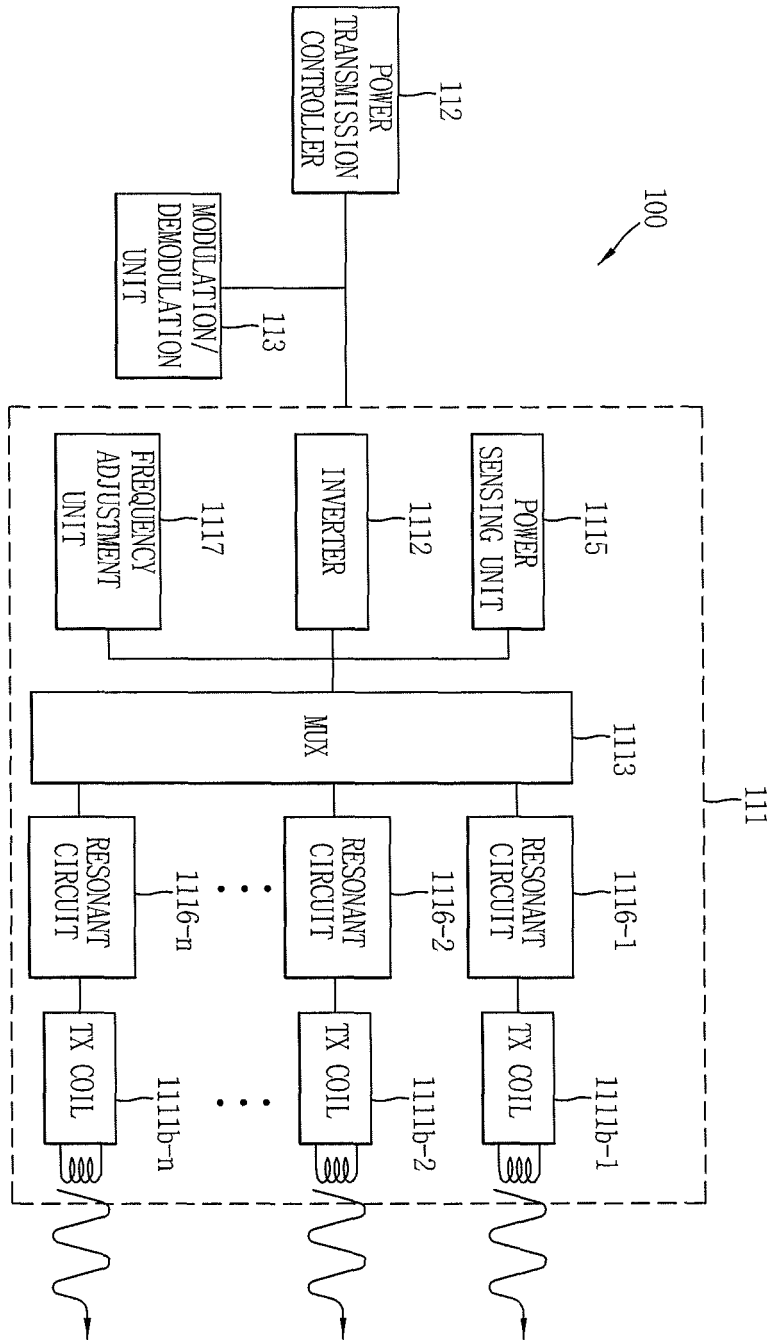

FIG. 9

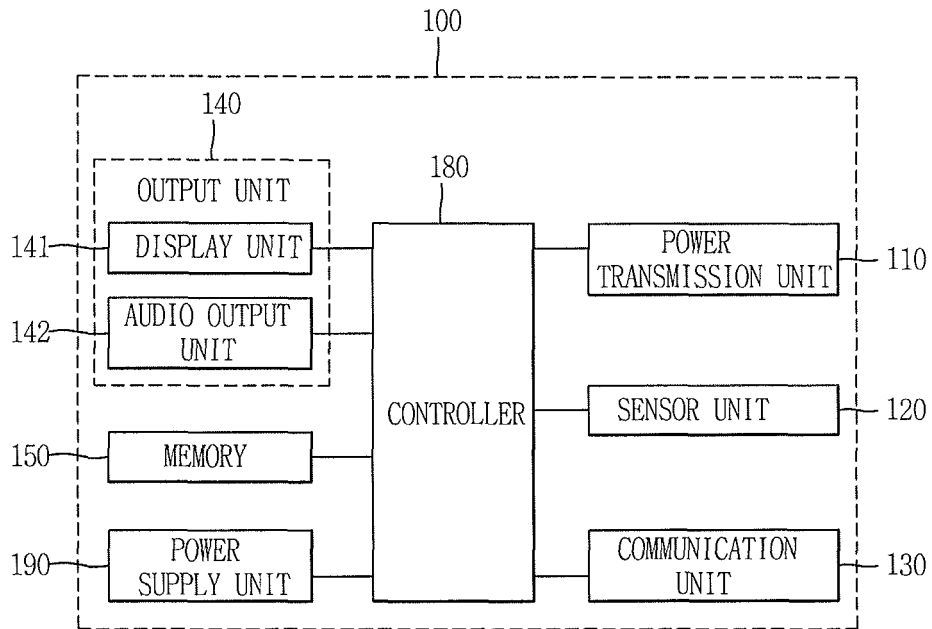

FIG. 10

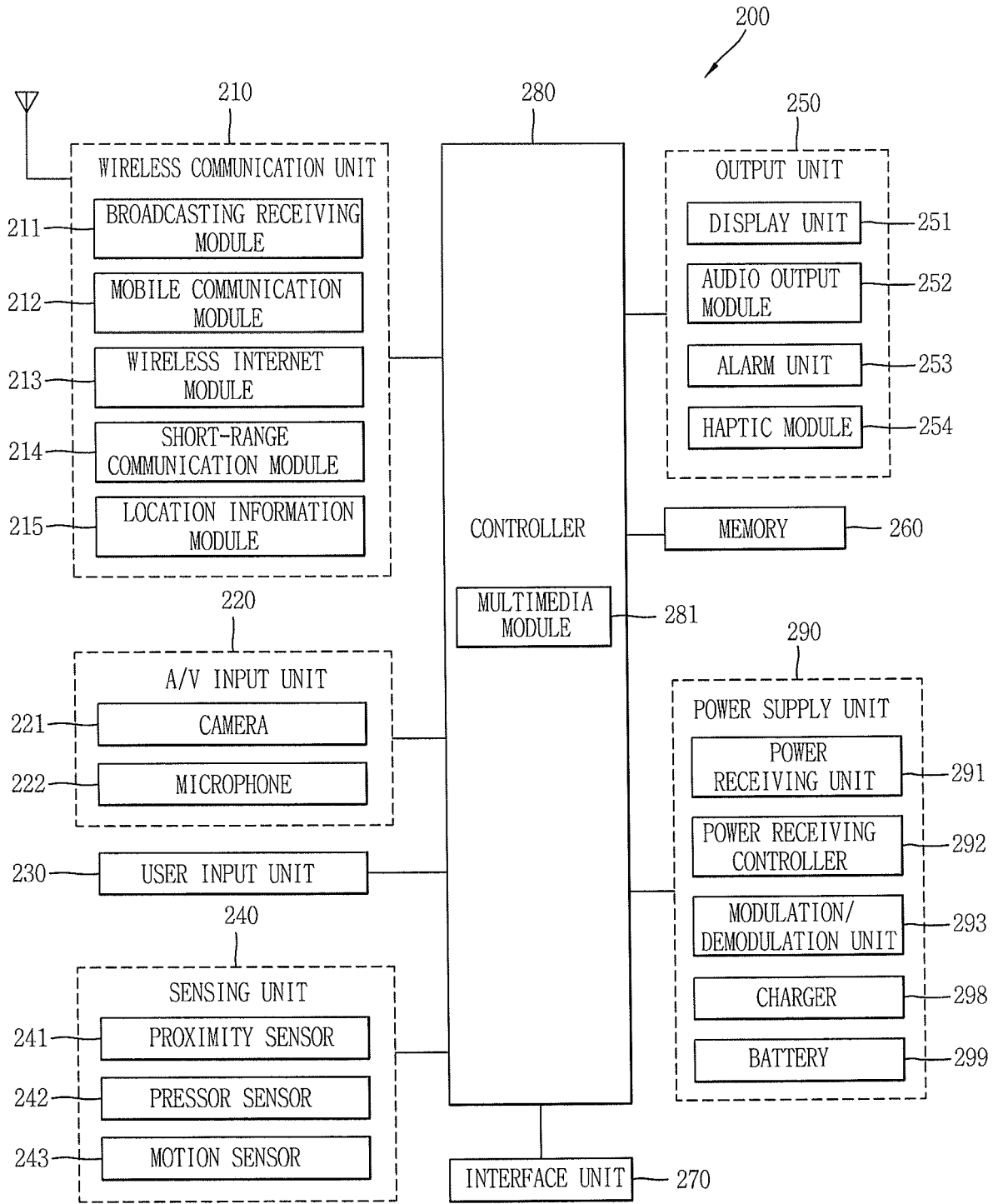

FIG. 11

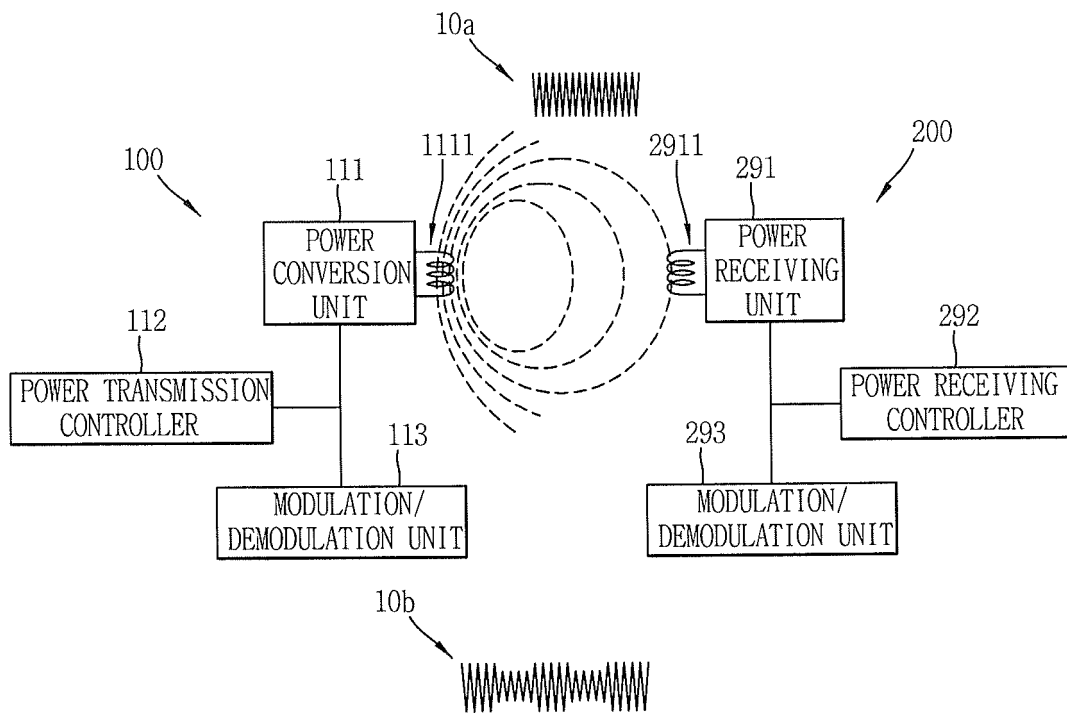

FIG. 12

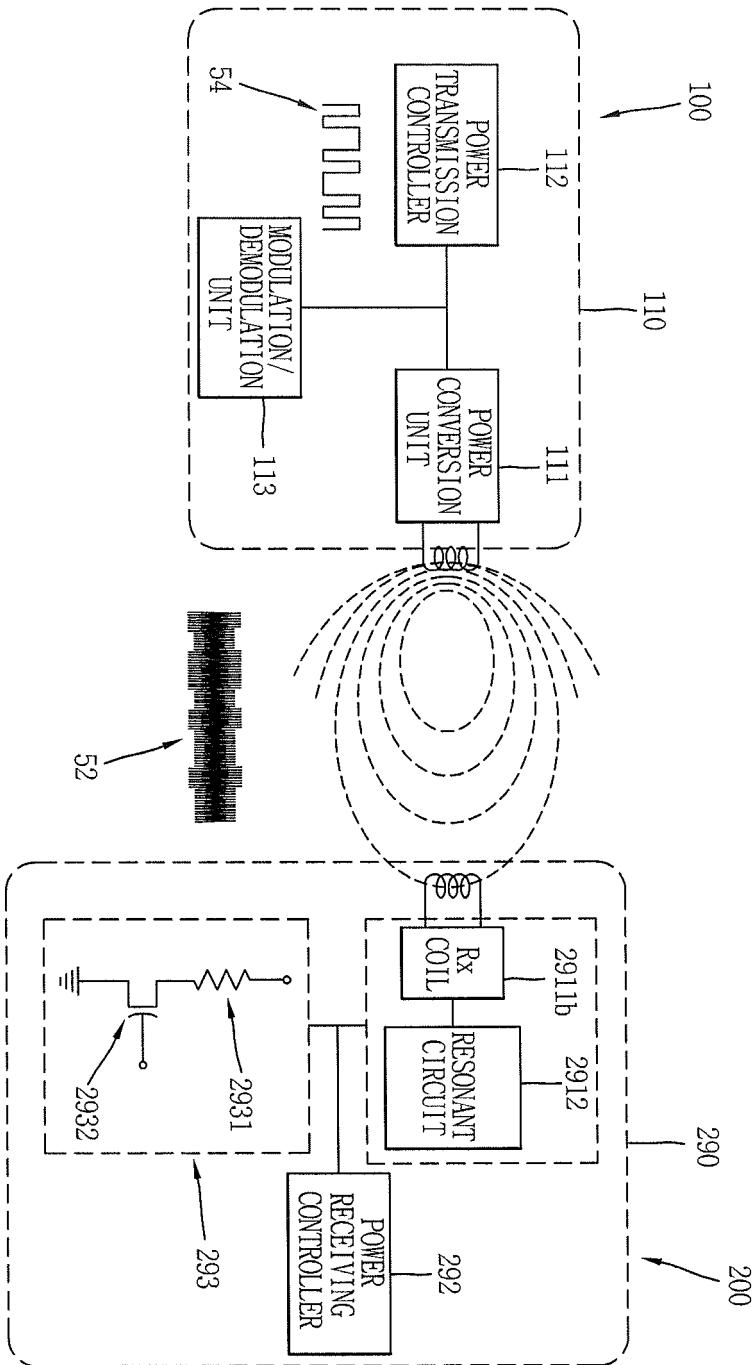

FIG. 13A

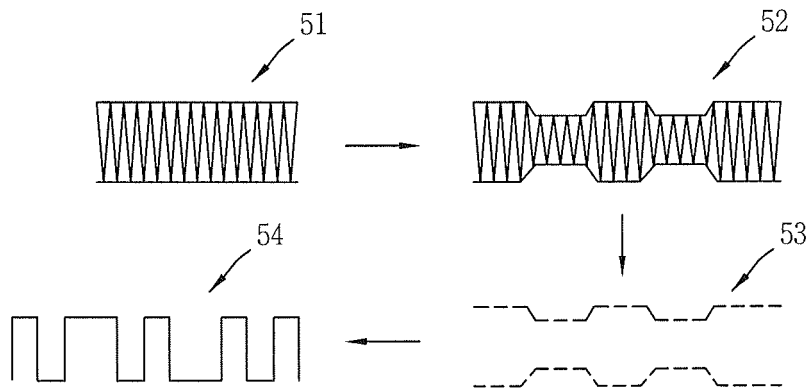

FIG. 13B

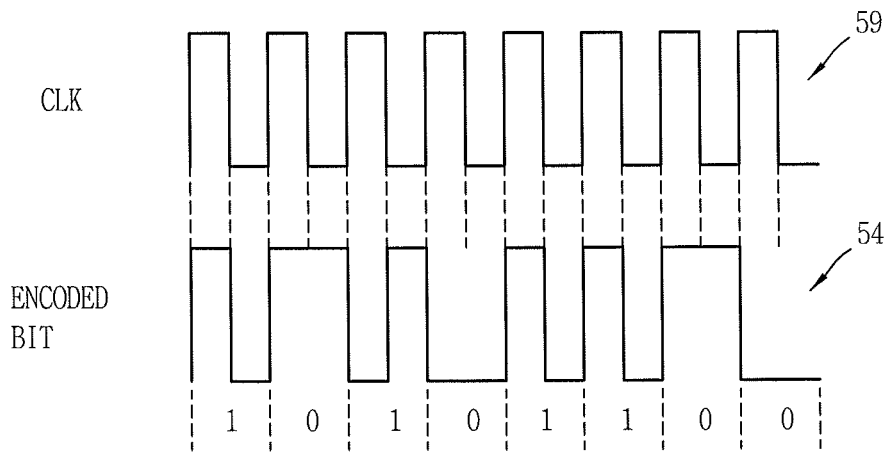

FIG. 13C

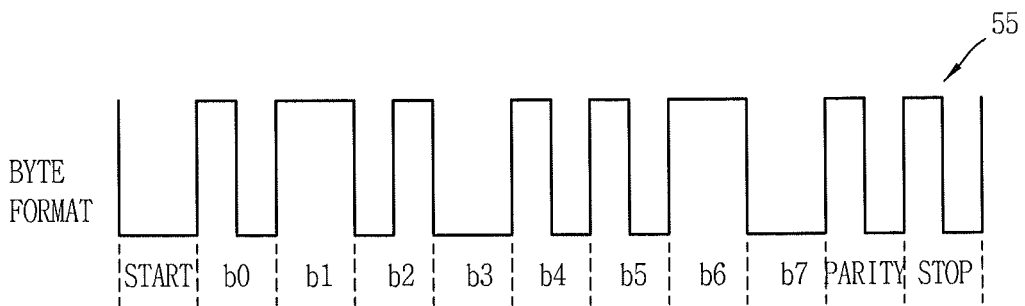

FIG. 14A

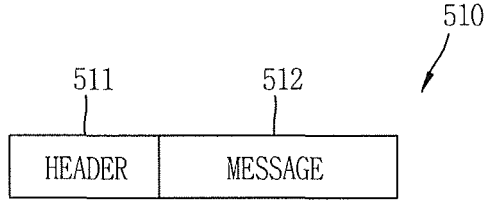

FIG. 14B

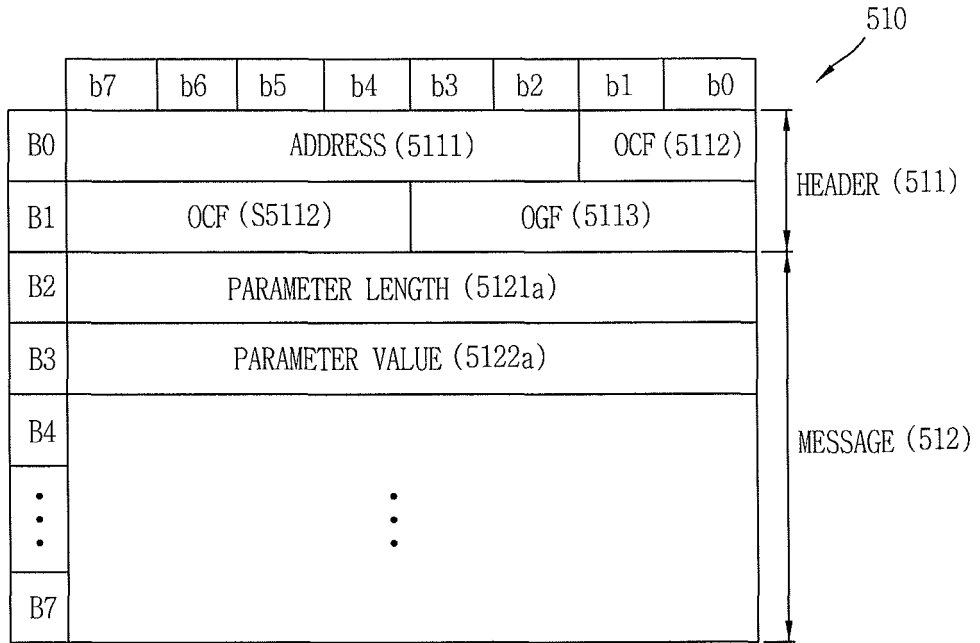

FIG. 14C

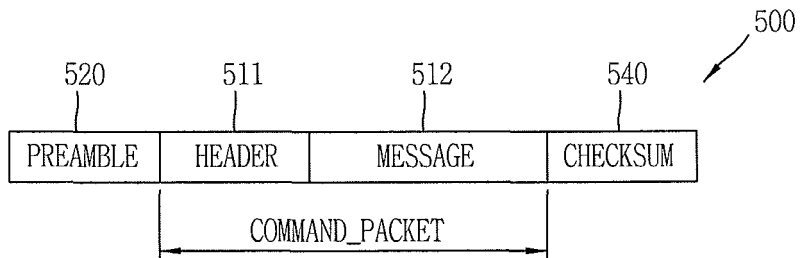

FIG. 15

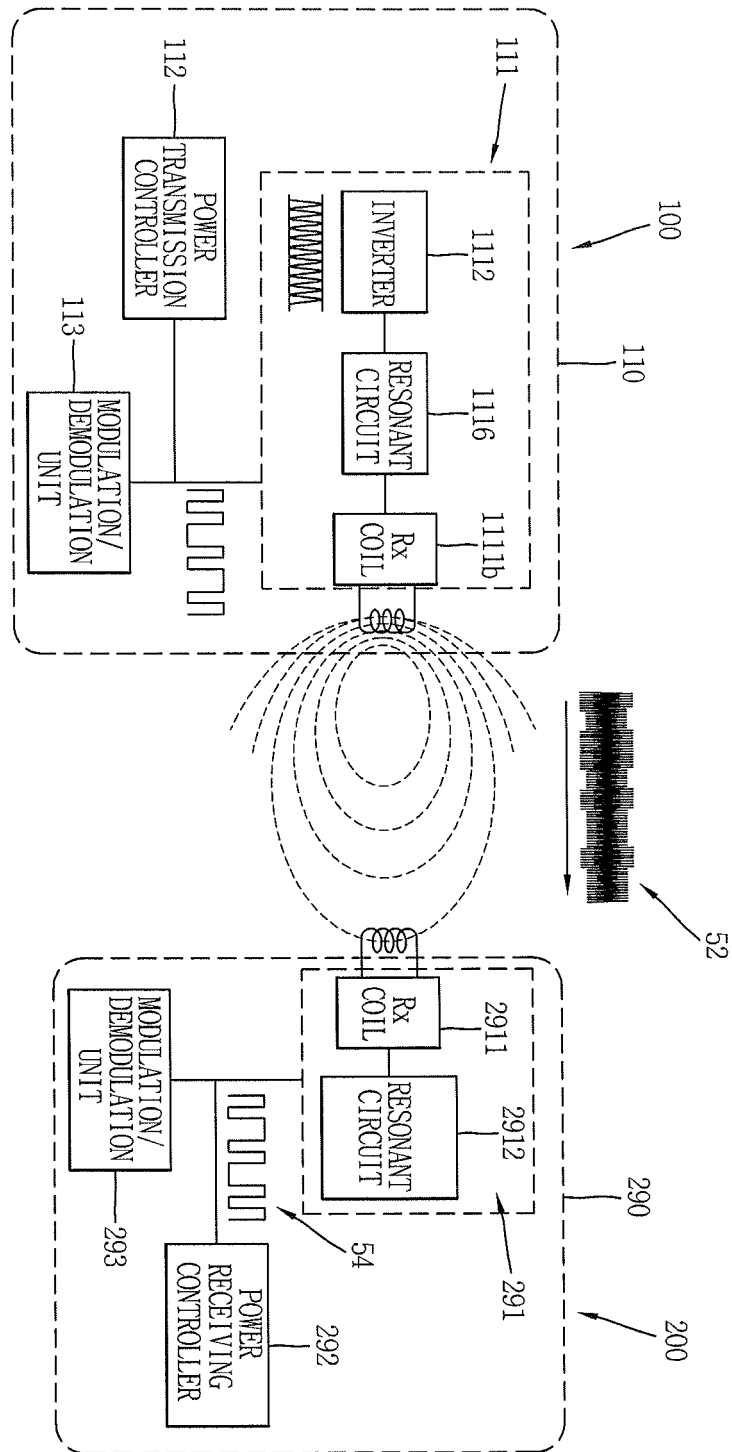

FIG. 16

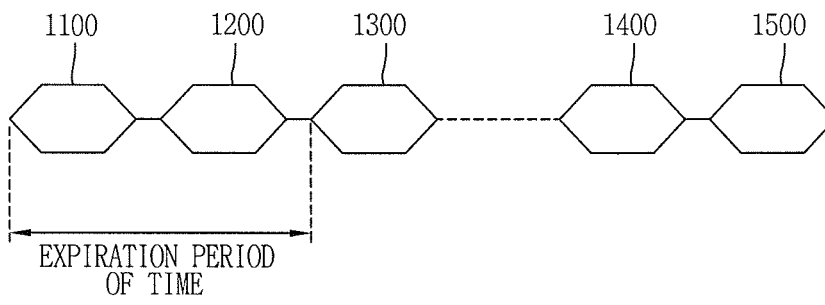

FIG. 17

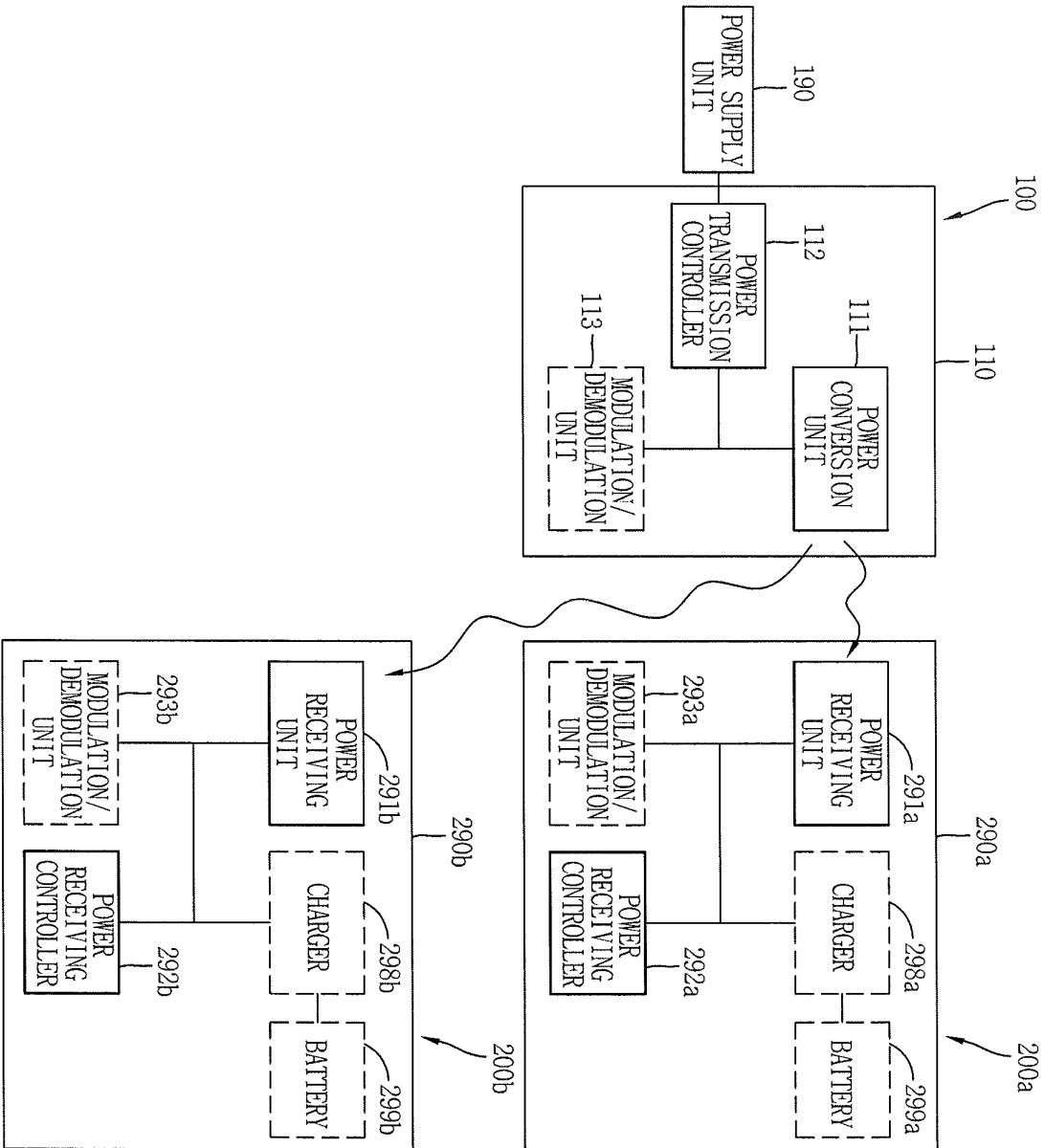

FIG. 18

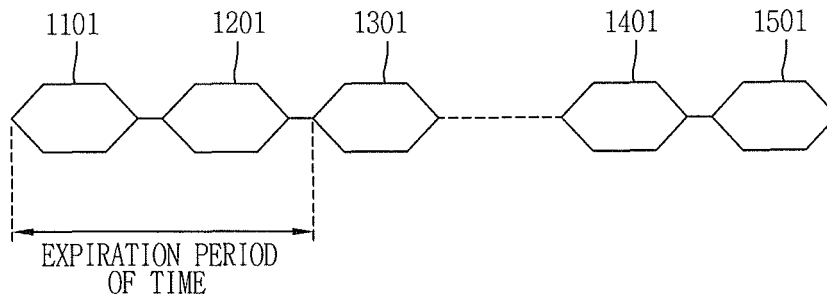

FIG. 19A

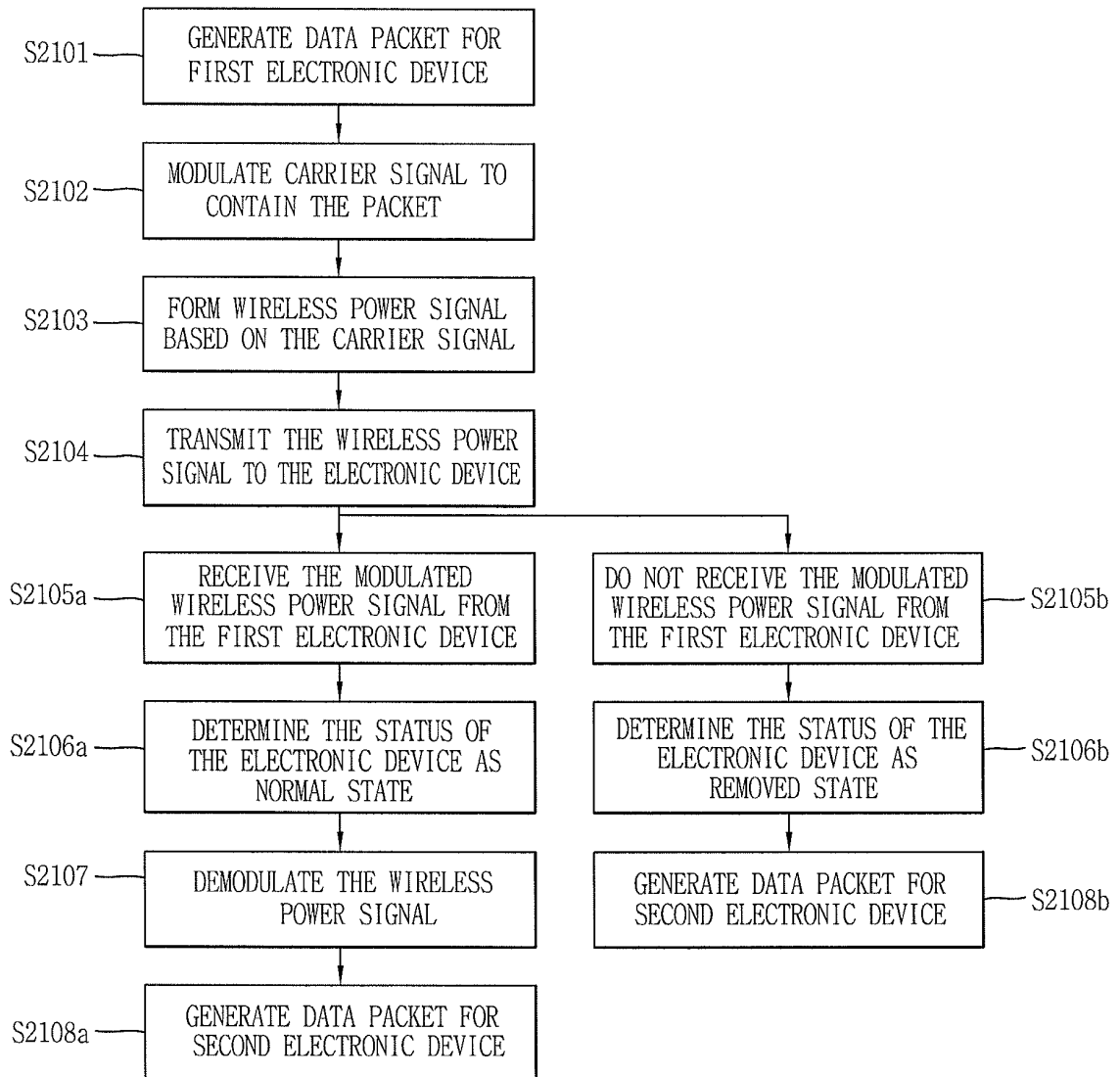

FIG. 19B

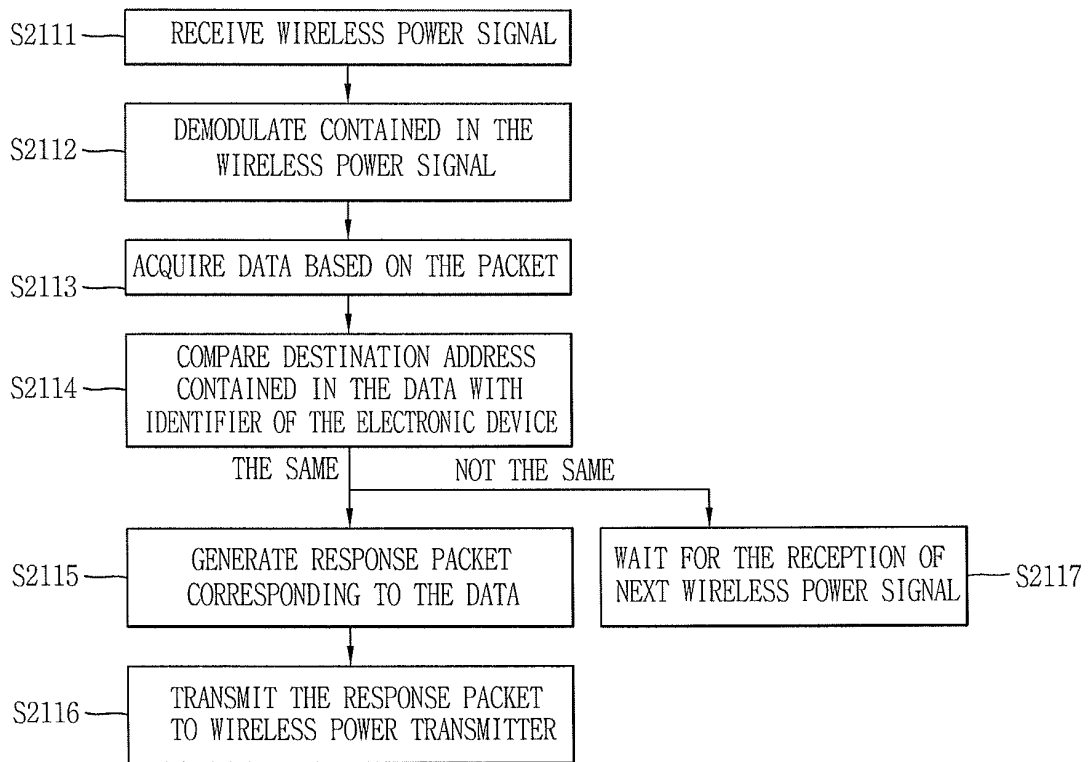
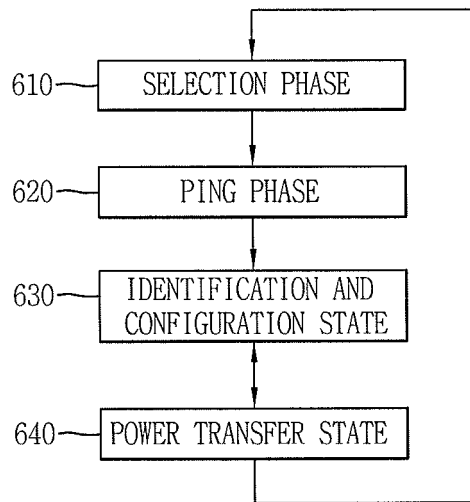



FIG. 20



INTERNATIONAL SEARCH REPORT

International application No.

PCT/KR2011/005330

A. CLASSIFICATION OF SUBJECT MATTER H04L 27/00(2006.01)i; H02J 17/00(2006.01)i; H04B 5/02(2006.01)i According to International Patent Classification (IPC) or to both national classification and IPC		
B. FIELDS SEARCHED Minimum documentation searched (classification system followed by classification symbols) H04L 27/00; H04B 7/00; H04B 5/00; H02J 7/00; H02J 17/00; H04B 5/02 Documentation searched other than minimum documentation to the extent that such documents are included in the fields searched Korean Utility models and applications for Utility models: IPC as above Japanese Utility models and applications for Utility models: IPC as above Electronic data base consulted during the international search (name of data base and, where practicable, search terms used) eKOMPASS (KIPO internal) & Keywords: wireless power transfer, identifier, group, power signal decoding		
C. DOCUMENTS CONSIDERED TO BE RELEVANT		
Category*	Citation of document, with indication, where appropriate, of the relevant passages	Relevant to claim No.
A	KR 10-2010-0012944 A (TAESAN LCD CO.,LTD.) 09 February 2010 See abstract; figures 1-2; paragraphs [0024]-[0038]	1-30
A	KR 10-2004-0028312 A (KOREA ADVANCED INSTITUTE OF SCIENCE AND TECHNOLOGY) 03 April 2004 See abstract; figures 2, 9; pages 4-5	1-30
A	KR 10-2010-0062416 A (SAMSUNG ELECTRONICS CO., LTD.) 10 June 2010 See abstract; figures 3-4; paragraphs [0034]-[0056]	1-30
A	KR 10-2007-0015264 A (LS CORP.) 02 February 2007 See abstract; figures 1-2; pages 5-6	1-30
<input type="checkbox"/> Further documents are listed in the continuation of Box C.		<input checked="" type="checkbox"/> See patent family annex.
* Special categories of cited documents:		
"A" document defining the general state of the art which is not considered to be of particular relevance	"T" later document published after the international filing date or priority date and not in conflict with the application but cited to understand the principle or theory underlying the invention	
"E" earlier application or patent but published on or after the international filing date	"X" document of particular relevance; the claimed invention cannot be considered novel or cannot be considered to involve an inventive step when the document is taken alone	
"L" document which may throw doubts on priority claim(s) or which is cited to establish the publication date of another citation or other special reason (as specified)	"Y" document of particular relevance; the claimed invention cannot be considered to involve an inventive step when the document is combined with one or more other such documents, such combination being obvious to a person skilled in the art	
"O" document referring to an oral disclosure, use, exhibition or other means	"&" document member of the same patent family	
"P" document published prior to the international filing date but later than the priority date claimed		
Date of the actual completion of the international search 28 MARCH 2012 (28.03.2012)	Date of mailing of the international search report 28 MARCH 2012 (28.03.2012)	
Name and mailing address of the ISA/KR  Korean Intellectual Property Office Government Complex-Daejeon, 139 Seonsa-ro, Daejeon 302-701, Republic of Korea Facsimile No. 82-42-472-7140	Authorized officer Telephone No.	

Form PCT/ISA/210 (second sheet) (July 2009)

EP 2 736 206 A1

INTERNATIONAL SEARCH REPORT Information on patent family members

International application No.

PCT/KR2011/005330

Patent document cited in search report	Publication date	Patent family member	Publication date
KR 10-2010-0012944 A	09.02.2010	NONE	
KR 10-2004-0028312 A	03.04.2004	NONE	
KR 10-2010-0062416 A	10.06.2010	NONE	
KR 10-2007-0015264 A	02.02.2007	CN 101233666 C0	30.07.2008
		JP 2009-504117 A	29.01.2009
		US 2008-0211455 A1	04.09.2008
		US 8129942 B2	06.03.2012
		WO 2007-015599 A1	08.02.2007

Form PCT/ISA/210 (patent family annex) (July 2009)