

[54] **MAGNETICALLY LATCHED SWITCH AND CIRCUIT THEREFOR**

3,253,098 5/1966 Perry.....335/179
3,404,465 10/1968 Charamond.....335/174

[72] Inventors: **Wilbert E. Beller**, Park Ridge; **Abed G. Kahale**, Roselle, both of Ill.

Primary Examiner—John J. Camby
Attorney—John W. Michael, Gerrit D. Foster, Bayard H. Michael, Paul R. Puerner, Joseph A. Gemignani, Andrew O. Riteris and Spencer B. Michael

[73] Assignee: **Controls Company of America**, Melrose Park, Ill.

[22] Filed: **Feb. 21, 1967**

[57] **ABSTRACT**

[21] Appl. No.: **617,630**

The switch-selector shaft is depressed to move latch plate against core magnetized by permanent magnet. This actuates various switches depending upon rotary position of the shaft. The termination pulse from the moisture sensing control passes through a coil to set up a counter magnetic field to allow a spring to move the latch and shaft to inactive position restoring switches to their normal positions.

[52] U.S. Cl. **34/45, 335/170**

[51] Int. Cl. **F26b 19/00, H01h 9/20**

[58] Field of Search200/4; 335/170, 174, 179; 34/45, 53

[56] **References Cited**

1 Claims, 5 Drawing Figures

UNITED STATES PATENTS

3,229,381 1/1966 Chafee.....34/45

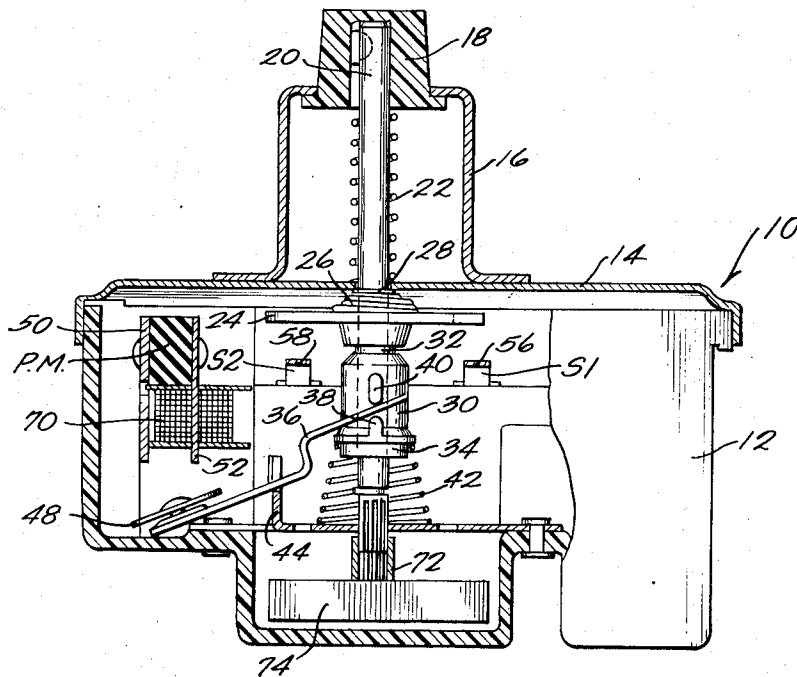

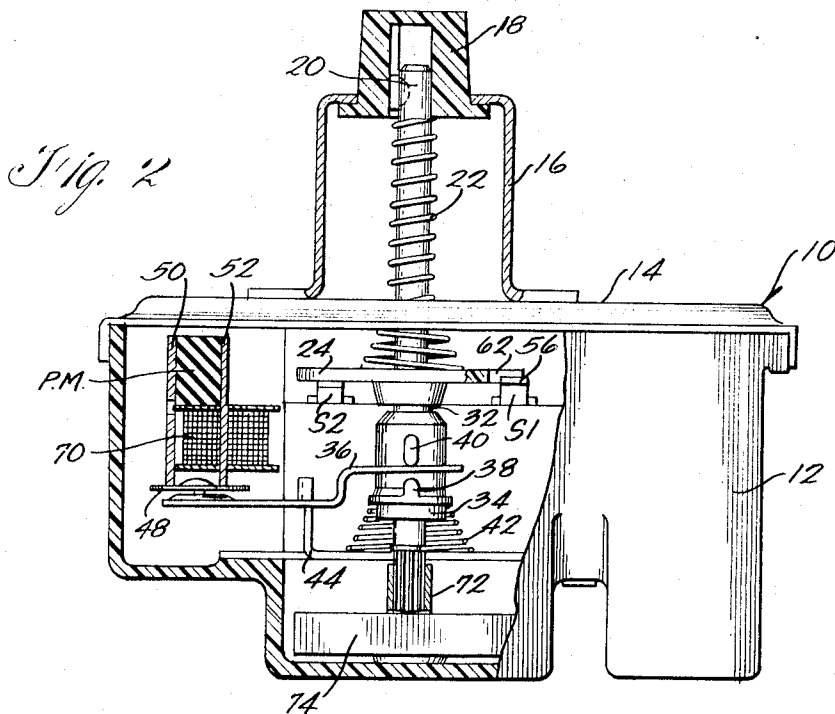
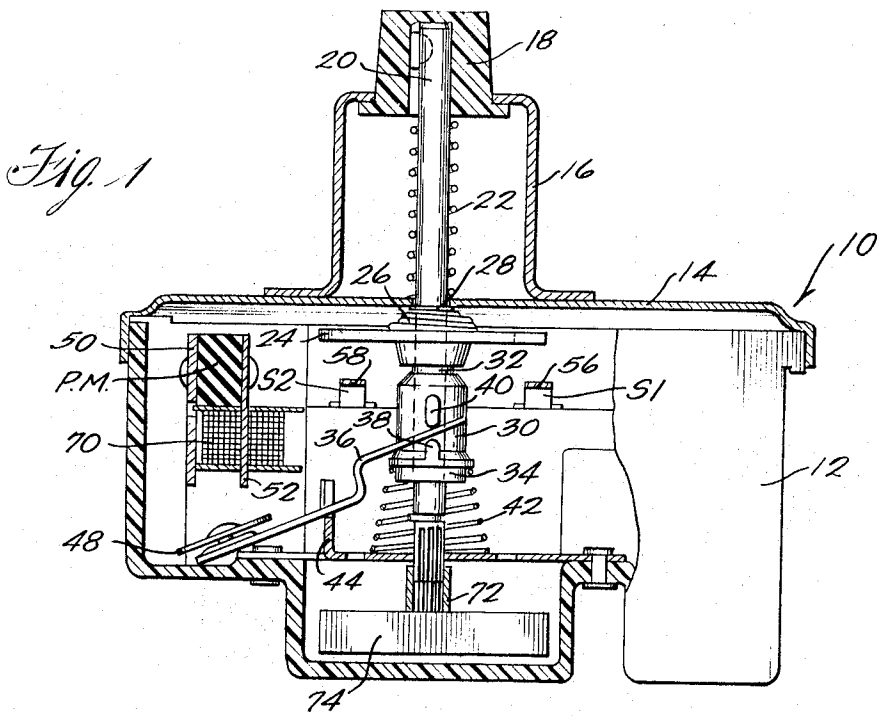

Inventors
Wilbert E. Beller
Abel G. Kahala
By *Barrett H. Michael*
Attorney

Fig. 3

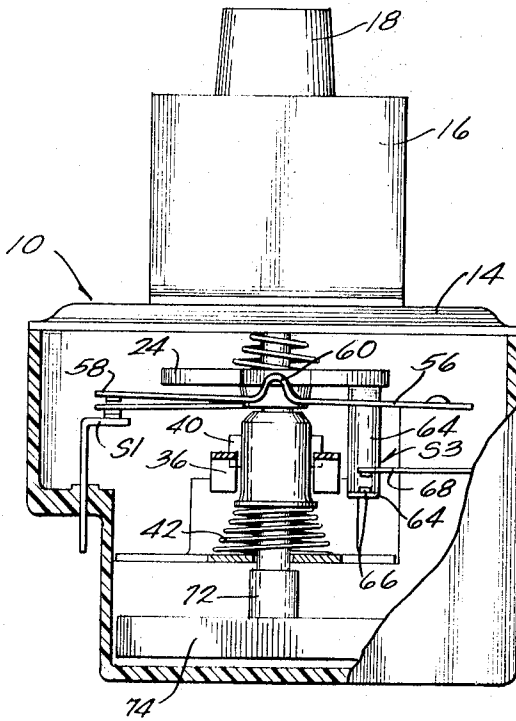
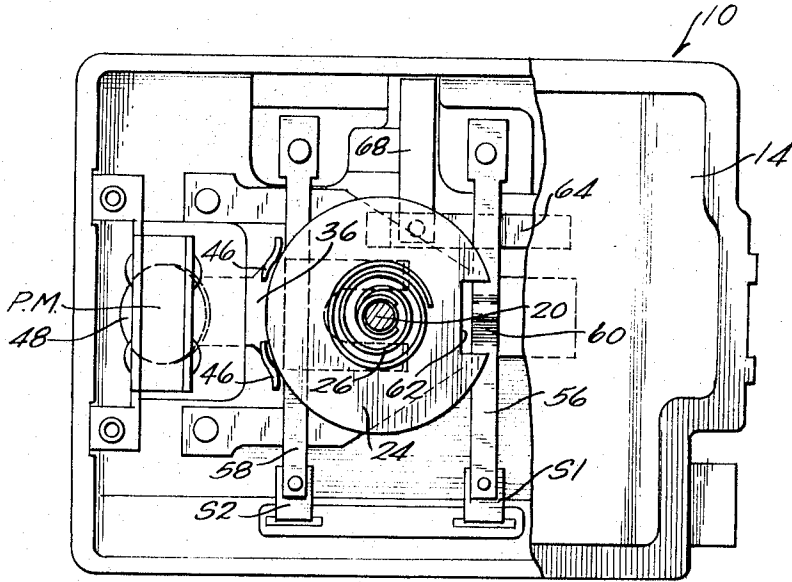

Fig. 1

Inventors
Wilbert E. Better
Abel G. Karate
By: *Bryant H. Michael*
Attorney

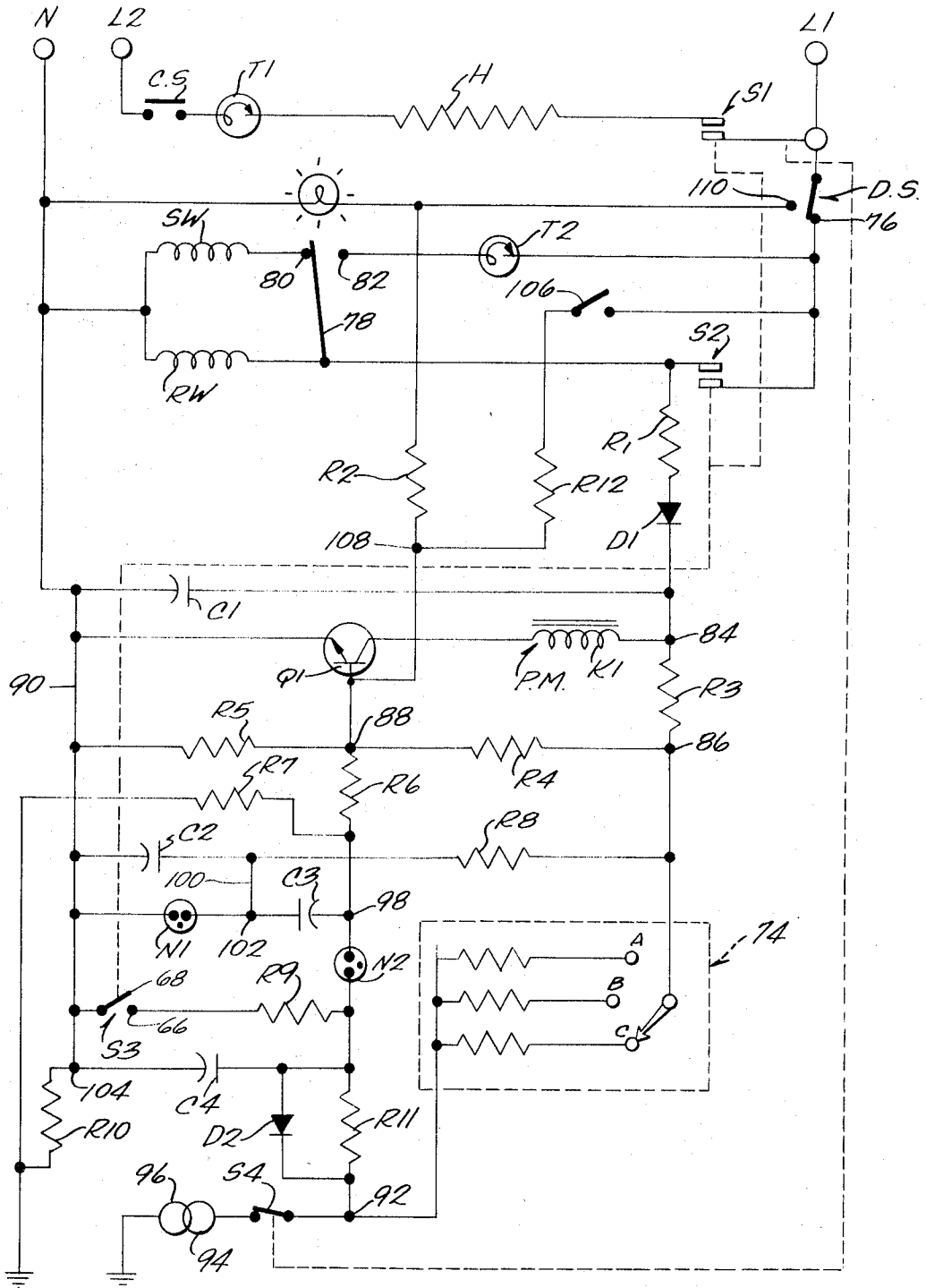

Fig. 5

Inventors
Wilbert E. Beller
Abel S. Kahale
By *Raymond H. Michael*
Attorney

MAGNETICALLY LATCHED SWITCH AND CIRCUIT THEREFOR

CROSS-REFERENCES TO RELATED APPLICATIONS

The voltage regulation aspect of the present disclosure is claimed in application Ser. No. 617,696 filed on Feb. 21, 1967, now U.S. Pat. No. 3,443,163.

The external termination aspect of the present disclosure is claimed in application Ser. No. 617,631 filed on Feb. 21, 1967 now abandoned.

The oscillator trigger circuit for the neon bulb is claimed in application Ser. No. 617,697 filed on Feb. 21, 1967, now abandoned.

The circuit for sensing reversed polarity of the line is claimed in application Ser. No. 617,629 filed on Feb. 21, 1967, now U.S. Pat. No. 3,445,676.

BACKGROUND OF INVENTION

Dryer controls of the moisture sensing type yield an electric signal upon reaching a desired moisture level of the contents of the dryer. On receipt of the signal, power switching is required and this has generally required a relay and would usually require additional semiconductors in the circuit.

SUMMARY OF INVENTION

In lieu of the relay of the prior art this invention provides a switching arrangement which is actuated by manual movement of a latch plate against a permanent magnet keeper, the field of which is opposed and cancelled by the electromagnetic field of a coil when a predetermined current passes through the coil in response to a dry signal from the moisture control circuit or in response to other termination signals. This system avoids the need for a holding relay and can operate on a single positive pulse to operate heavy duty power switching.

DESCRIPTION OF DRAWINGS

FIG. 1 is a vertical section through the selector switch in the inactive position;

FIG. 2 shows the switch of FIG. 1 moved to its active position;

FIG. 3 is a horizontal section showing the selector in a rotary position to not actuate the heater switch;

FIG. 4 is a side view of FIG. 3; and

FIG. 5 is a wiring diagram incorporating some schematic showings of the operation.

DESCRIPTION OF PREFERRED EMBODIMENT

The selector switch is enclosed in a housing 10 including lower portion 12 and cover 14 which is provided with projecting enclosure 16 having an aperture through which the knob 18 projects. The knob is keyed to shaft 20 and a spring 22 is compressed between the underside of the knob and the upper surface of cover 14 to bias the knob outwardly but permit inward motion of the knob. Circular plate 24 is slidably carried by the shaft 20 below the cover plate for rotation with the shaft 20. The plate is urged downwardly against a stop on the shaft by spring 26 compressed between the plate and retaining ring 28. Sleeve 30 is loosely carried on shaft 20 between suitable retaining or stop rings 32,34. The sleeve 30 is retained against absolute rotation by reason of the forked ends of the pivoted latch straddling the sleeve and fitting snugly into the flatted portions on opposite sides of the sleeve between the spaced pairs of ears 38,40. Thus the downward movement of the shaft and sleeve will result in moving the forked ends of the latch downwardly by reason of the engagement of the upper pair of ears 40 with the ends of the latch. Similarly, if the spring 42 is allowed to move the sleeve upwardly, the lower pair of ears 38 will move the latch 36 counterclockwise as viewed in FIGS. 1 and 2.

The latch 36 is pivoted on the upstanding bracket 44 and retained in position by ears 46 turned inwardly as seen best in FIG. 3. The left-hand end (FIGS. 1 and 2) of the latch

rockably carries a ferrous latch plate 48 which, when the latch is pivoted to the generally horizontal position shown in FIG. 2, will move up against the spaced ferrous keepers 50,52 between the upper ends of which there is mounted a permanent magnet PM polarized as to have a vertically oriented magnetic field which, in turn, will vertically magnetize the keepers 50 and 52. When the latch plate 48 comes into contact with the keepers, the latch plate and latch will be held in position.

The latch can be moved from the position shown in FIG. 1 to the position shown in FIG. 2 by depressing knob 18. This will move the sleeve 30 downwardly and rock the latch as described above. At the same time it will move the circular plate 24 downwardly to strike the spaced blades 56 and 58 of switches S_1 and S_2 , respectively, assuming the plate is positioned as to overlie both upwardly bent medial portions 60. As shown, there is a notch 62 in the plate which is shown overlying blade 56 so that when the plate is moved downwardly in this rotary position switch S_1 will not be closed, as may be seen clearly in FIG. 4. In all other rotary positions of the plate 24 the switch S_1 would be actuated along with switch S_2 . This permits rotary movement of the knob to select a different mode of operation by omitting actuation of switch S_1 . This mode of operation is associated with "air fluff" operation of a clothes dryer in which no heat is desired.

In FIGS. 3 and 4 it will be noted that there is a resilient switch blade 64 having one end turned up to underlie the circular plate 24. When the knob and circular plate 24 are in their outer positions this switch S_3 will be closed with terminal 66 contacting fixed terminal 68 but when the plate is moved downwardly it will strike the upstanding end of the blade 64 to open contacts 66,68. When the latch is released for return to its normal position (FIG. 1) switch S_1 will again be closed. The purpose of this operation is to restore the dryer control for another cycle by discharging the capacitor.

Coil K_1 is wound on a bobbin mounted on ferrous keeper 52. This coil is wound so that a DC pulse or a positive going AC pulse through the coil will produce a magnetic field opposite the field of the permanent magnet. Assuming a pulse of sufficient magnitude, this will neutralize the two magnetic fields and permit spring 42 to return the latch to its normal position. Thus, release of this latch mechanism is effected within less than one-sixtieth of a second (assuming a supply of 60 hertz).

It will be noted that the lower end of shaft 20 is splined to shaft 72 projecting upwardly from rotary switch 74. The position of knob 18 determines the selection made by switch 74 and also determines whether switch S_1 will be actuated along with the air fluff switch S_3 within the dryer control per se (as will appear in connection with the description of the circuit dryer diagram). It will be obvious that all of these switches can be keyed together in a very simple manner. Additional switches will frequently be keyed into the rotary position of this switch.

When knob 18 is depressed, the plate 24 will normally act to close both of the principal switches S_1 and S_2 . Closing S_1 places the heater H across the lines L_1, L_2 with the thermostat T_1 and centrifugal motor switch CS in series. Thus the heater H cannot be energized until the motor is up to speed and then will be intermittently energized in accordance with the temperature conditions.

Closure of switch S_2 will, if door switch DS is closed on terminal 76, apply power to the motor M with the run winding RW and the start winding SW in parallel until the motor is up to speed and the centrifugal switch 78 transfers from terminal 80 to terminal 82 to drop out the start winding SW. It will be noted that at this time there is a parallel path on the supply to the motor winding RW so that on termination of operation (opening switch S_2) the cool down thermostat T_2 will continue running the motor until the temperature within the dryer has dropped to the desired level.

Closure of switch S_2 also acts to supply the control through resistance R_1 and diode D_1 . The DC voltage passing D_1 is

smoothed by capacitor C_1 and the filtered DC is applied to junction **84** at one side of coil K_1 , the other side of which is connected to the collector terminal of transistor Q_1 . The DC is further dropped through resistance R_3 and at junction **86** there is a voltage divider with resistance R_4 connected between **86** and junction **88** which is, in turn, connected to the base of transistor Q_1 . The emitter of transistor Q_1 is connected to line **90** which is connected to the N terminal. At this point it should be noted that by reason of the provision of R_4 there will be enough voltage applied to the base to cause a small current through coil K_1 . This will not be enough to overcome the permanent magnet PM. Now if the voltage at **86** increases, the bias on the transistor Q_1 will increase and increase the current through the coil which will, in turn, reduce the voltage at **86**. This, therefore, constitutes a voltage regulation arrangement at very little extra cost and which will greatly improve the performance of the control. The arrangement is shown and claimed in the above mentioned application Ser. No. 617,696.

The voltage is then applied to the rotary switch **74** which will select one of the resistors which, in turn, determines the voltage supply to junction **92** which is applied through the normally closed switch S_4 to ring **94** inside the dryer drum. The clothes will bridge this ring and grounded ring **96** so that the charge at junction **92** will leak off to ground at a rate depending upon the moisture content of the clothes in the dryer or, stated another way, upon the effective resistance offered by the clothes in the dryer. This resistance increases as the clothes dry. The voltage at **92** is applied to capacitor C_4 through resistor R_{11} . The resistance R_{11} is selected to give a suitable time delay in combination with C_4 to allow for the characteristics of the installation of the rings within the dryer and for light load conditions where the contents of the dryer may not bridge the rings very often. In some cases the time constant necessary becomes somewhat substantial so that resistance R_{11} must also become rather substantial, keeping in mind that it is much less expensive to provide resistance than it is to provide capacitance. In such cases, if the rings are then bridged by a rather wet material, it takes too long to discharge the capacitor C_4 through the resistance R_{11} . For this reason the shunting diode D_2 is provided to provide for rapid discharge of capacitor C_4 when a moist signal is received after having built up a substantial charge on the capacitor. This technique is old in comparable circuits. See U.S. Pat. Nos. 2,949,547, 2,942,123, 2,970,228, 3,073,972, all relating to timing circuits.

When the charge on capacitor C_4 reaches a predetermined value, the neon bulb N_2 breaks down and becomes conductive. This sends a pulse from the neon past junction **98** through R_6 to the base of transistor Q_1 to bias it "on" and cause a substantial pulse through coil K_1 which, being a positive pulse, overcomes the permanent magnet PM and allows the latch to return to its inactive position opening switches S_1 and S_2 and closing switch S_3 . As the breakdown voltage of N_2 is approached and particularly where the rate of charge on the capacitor C_4 is slow, the leakage current through N_2 increases to the point where accuracy of the control is adversely affected. To overcome this problem, an oscillator is applied to the circuit. This oscillator circuit includes resistance R_8 connected from the supply line to one side of capacitor C_2 , the other side of which is connected to lead **90**. Lead **100** connects between capacitor C_2 and junction **102** between one side of capacitor C_3 and one terminal of neon bulb N_1 . The other side of C_3 is connected to junction **98** and the other side of N_1 is connected to **90**. Capacitor C_2 is charged until the breakdown voltage of N_1 is reached and, when N_1 conducts, the discharge of C_3 causes a negative pulse to appear at junction **98**. This is selected to be about minus 2 volts and when N_2 is within 2 volts of its breakdown voltage the appearance of the negative 2 volt pulse on the other side of N_2 will cause N_2 to conduct. In this manner the leakage condition in N_2 is

avoided. This feature is described in greater detail and is claimed in the aforesaid application.

Another interesting feature in the present circuit is the provision of resistor R_{10} between lead **90** and ground. In the prior art junction **104** between R_{10} and lead **90** would have been ground but with the present arrangement junction **104** is at ground potential only when N is properly connected to ground. If N is not connected to ground, that is, if the polarity of the voltage supply is reversed, the voltage at that junction **104** is different than ground. Ground is connected to R_6 through R_7 . This arrangement makes the circuit sensitive to reversal of polarity of the supply voltage since on the negative going AC voltage applied to N and, hence, lead **90** (there is no effect on the positive going portion of the sine wave) the emitter of Q_1 will now be going negative with respect to the base and the collector. This, therefore, will cause the transistor to be triggered and a positive pulse from C_1 through terminal **84** and coil K_1 will neutralize the magnetic field of the permanent magnet and allow the control to terminate operation. Thus the control and dryer cannot be put into operation with improper polarity of the voltage supply. This circuit avoids the need for an isolation transformer and is claimed in the aforesaid application.

Several other ways of terminating the operation are shown in this circuit. A separate "off" switch **106** is provided on the dryer control panel. When this switch is closed, voltage is applied through resistance R_{12} to junction **108** and thence to the base of transistor Q_1 and on the positive going side of the sine wave the transistor will be biased "on" and a pulse will be applied through the coil K_1 to terminate operation. Another method of terminating operation is with the door switch DS. When the door is opened, the blade moves from terminal **76** to terminal **110** which will now apply a voltage through resistance R_2 , junction **108**, to the base of transistor Q_1 to bias the transistor "on" and pulse the coil K_1 to terminate operation. The voltage for termination is obtained by discharging C_1 . This feature of external termination of the control is covered in the aforesaid application.

From the foregoing description it will be apparent that the present magnetic latch combined with the coil for releasing the latch lends itself to a low cost control system whereby the coil can be pulsed for termination by any of a number of conditions, that is, by normal operation of the control, by a manual actuation of a termination switch, or by means of a door switch, or by means of a reverse polarity condition on the voltage supply. In all cases a necessary positive pulse giving the proper magnetic field to the coil is available. The response time to unlatch is very fast.

When the latch is released to open switches S_1 and S_2 the switch S_3 is closed which will now discharge capacitor C_4 through resistance R_9 to set up the control for the next operation.

We claim:

1. A control mechanism comprising,
 - an actuator movable between active and inactive positions, means biasing the actuator to its inactive position, ferrous latch means engaged with the actuator and moved to an active position by the actuator when the actuator is moved to its active position,
 - permanent magnet keeper means for retaining the latch means in active position,
 - a coil associated with the keeper means and wound so a pulse of given sign and magnitude will oppose and neutralize the magnetic field of the keeper means so the biasing means can return the actuator to inactive position,
 - said keeper means including spaced ferrous keepers having a permanent magnet fixed therebetween, said coil being arranged on one of the keepers.

* * * * *