



US 20060010658A1

(19) **United States**

(12) **Patent Application Publication**  
**Bigley et al.**

(10) **Pub. No.: US 2006/0010658 A1**

(43) **Pub. Date: Jan. 19, 2006**

(54) **SNAP FASTENER FOR USE WITH FABRICS**

(30) **Foreign Application Priority Data**

(76) Inventors: **Mark Bigley**, Medrseyside (GB); **Peter Graham**, Gloucestershire (GB);  
**Gordon Burch**, Gloucestershire (GB);  
**John Ransome**, Gloucestershire (GB)

Jun. 26, 2002 (GB)..... 02147049

**Publication Classification**

(51) **Int. Cl.**

*A44B 1/32* (2006.01)

(52) **U.S. Cl.** ..... 24/114.05

Correspondence Address:

**MATHEWS, SHEPHERD, MCKAY, &  
BRUNEAU, P.A.**

**100 THANET CIRCLE, SUITE 306  
PRINCETON, NJ 08540 (US)**

(57) **ABSTRACT**

A snap fastener for use with fabrics comprising a flange having a cylindrical wall extending axially therefrom, the wall comprising a plurality of circumferentially extending engaging portions each engaging portion being separated from the next by a circumferentially extending non engaging portion.

(21) Appl. No.: **10/519,116**

(22) PCT Filed: **Jun. 26, 2003**

(86) PCT No.: **PCT/GB03/02748**

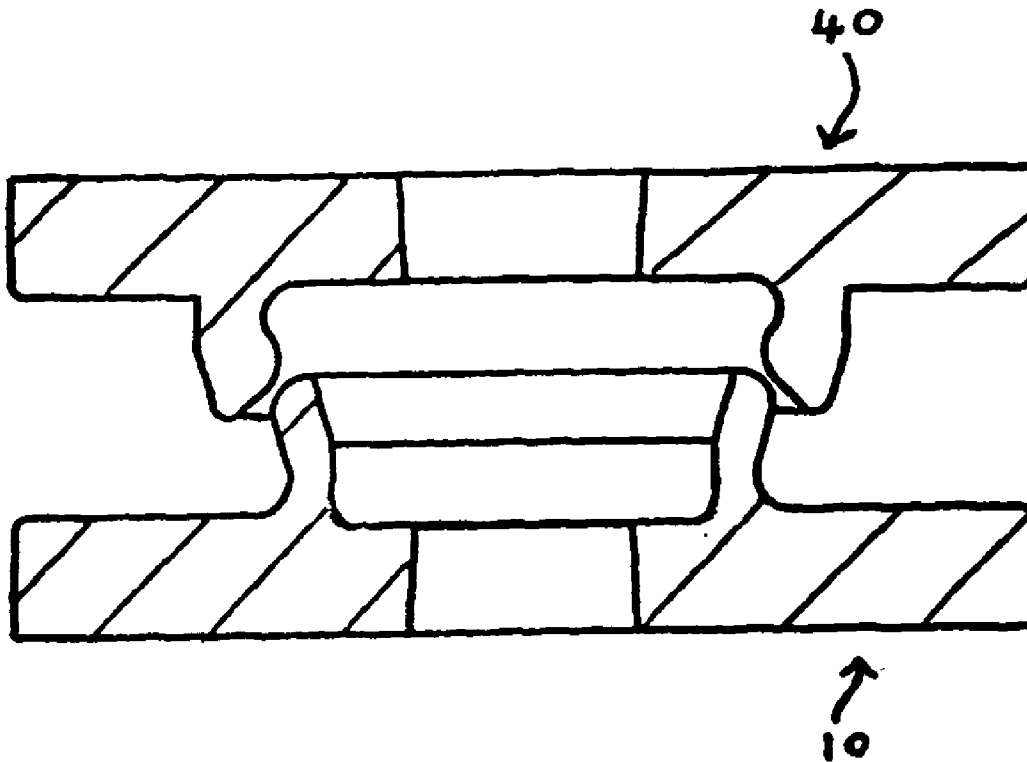

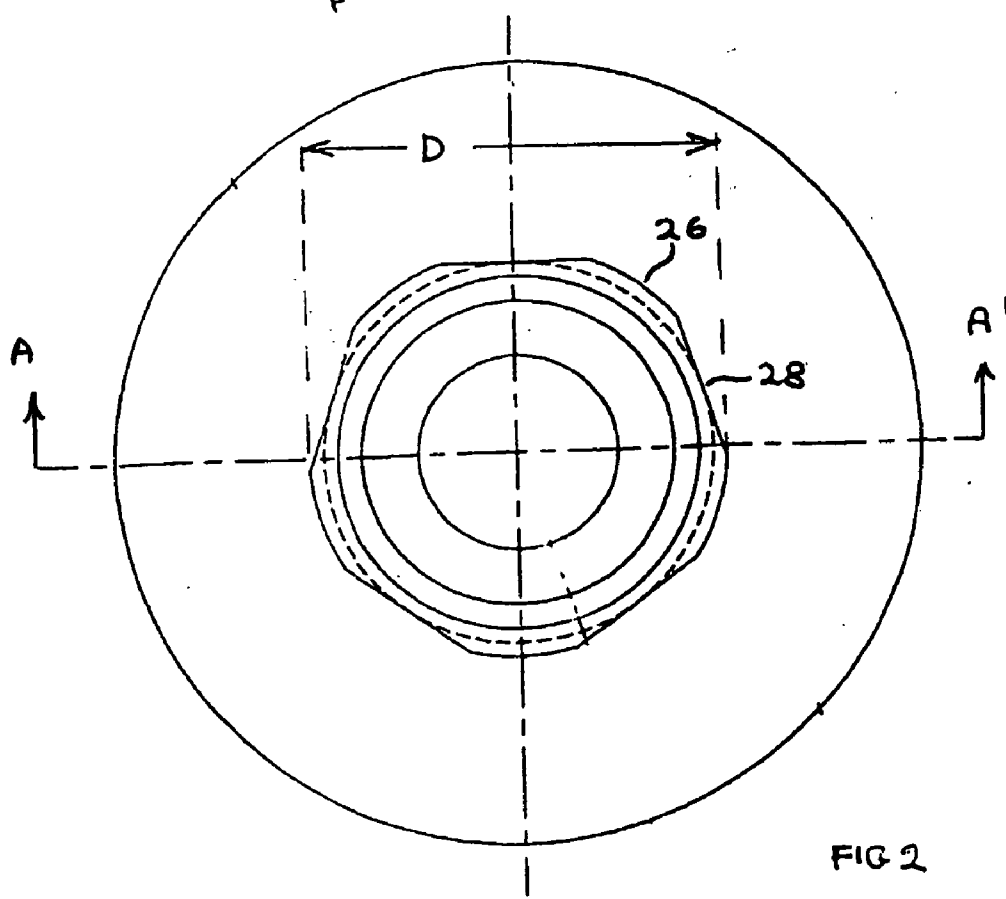
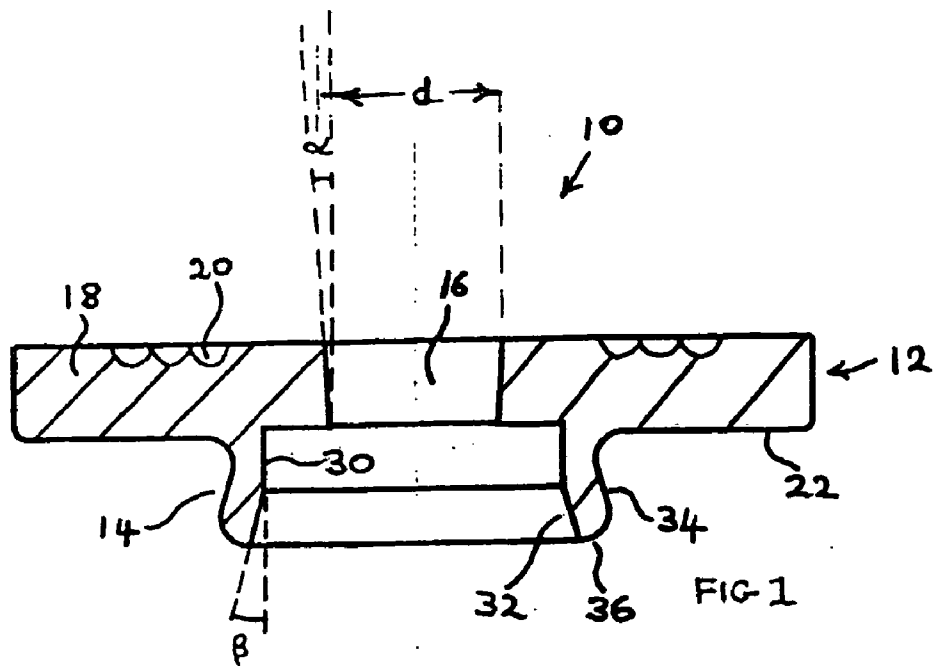

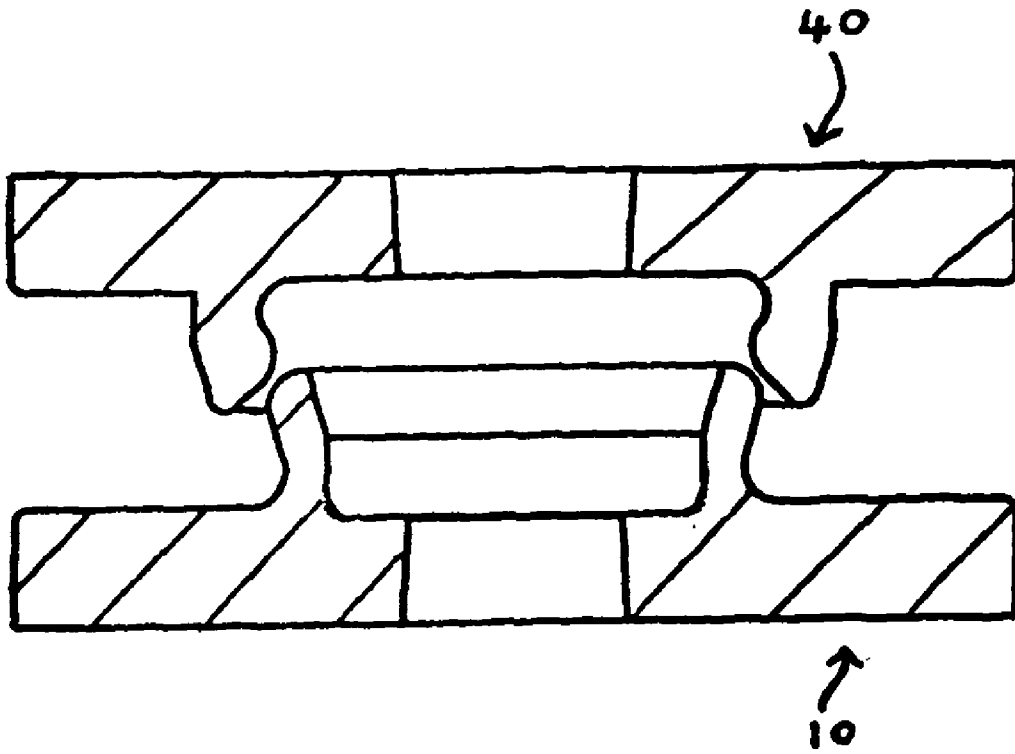

Fig 3

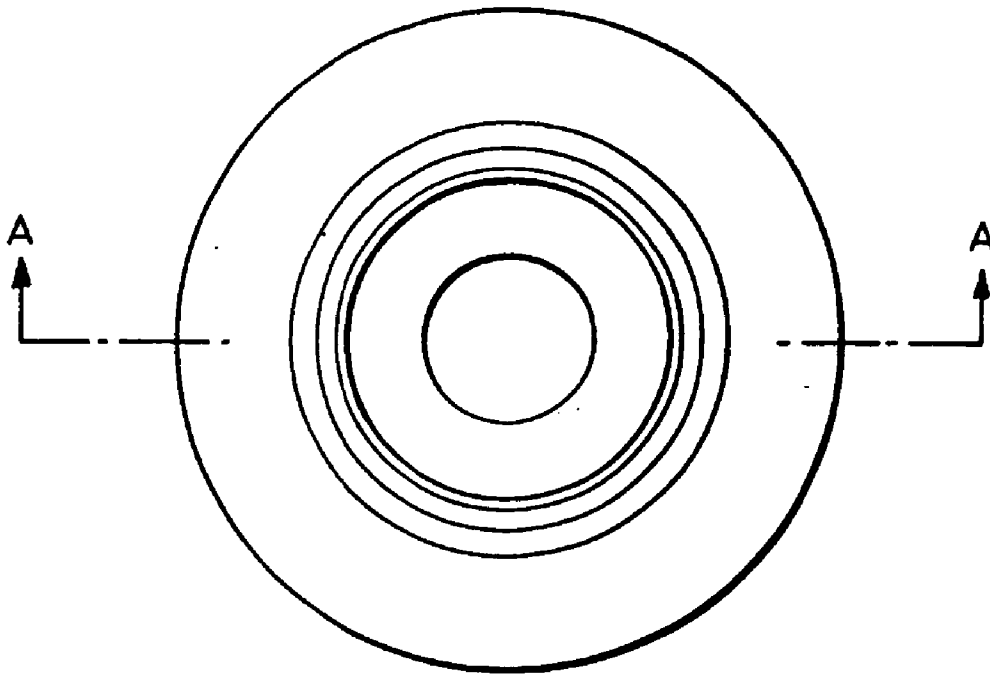

Fig. 4.

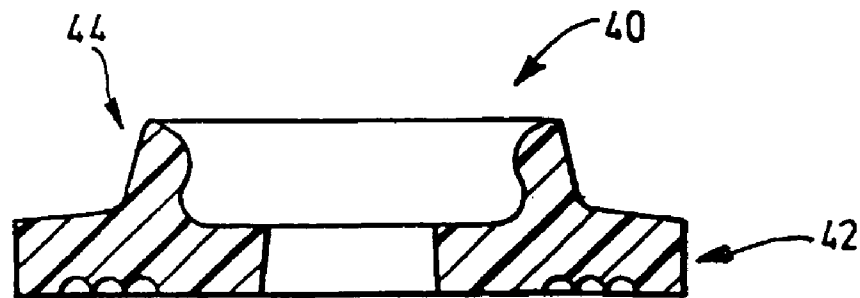

Fig. 5.

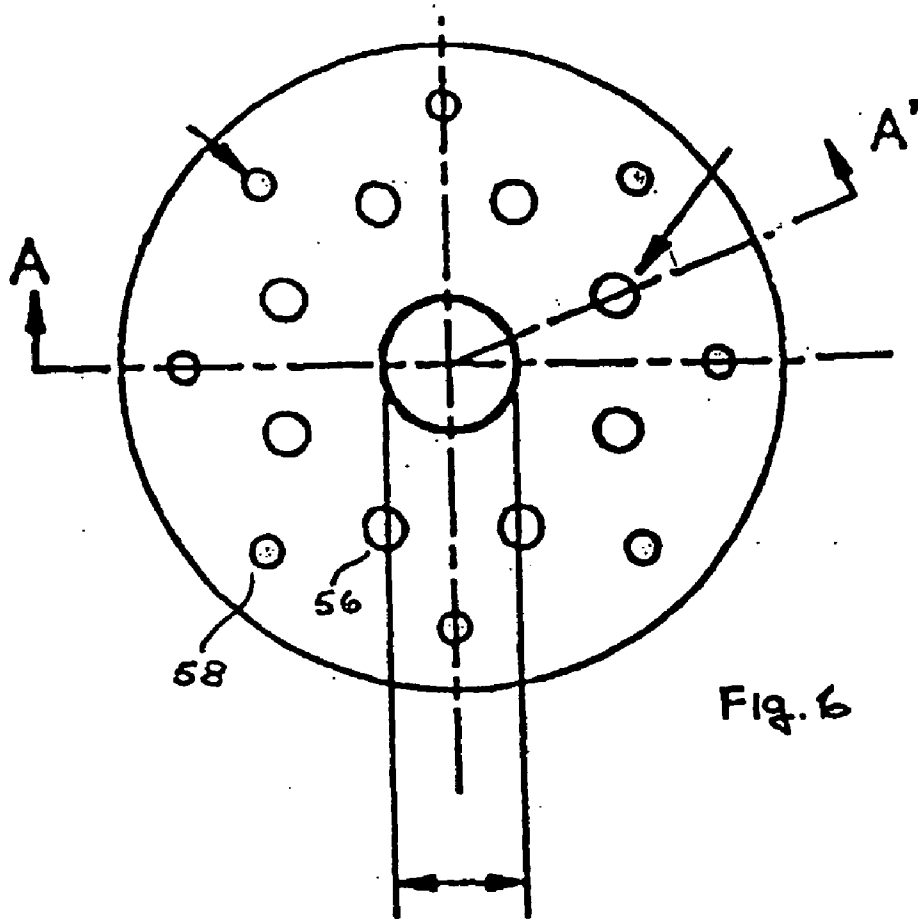

Fig. 6

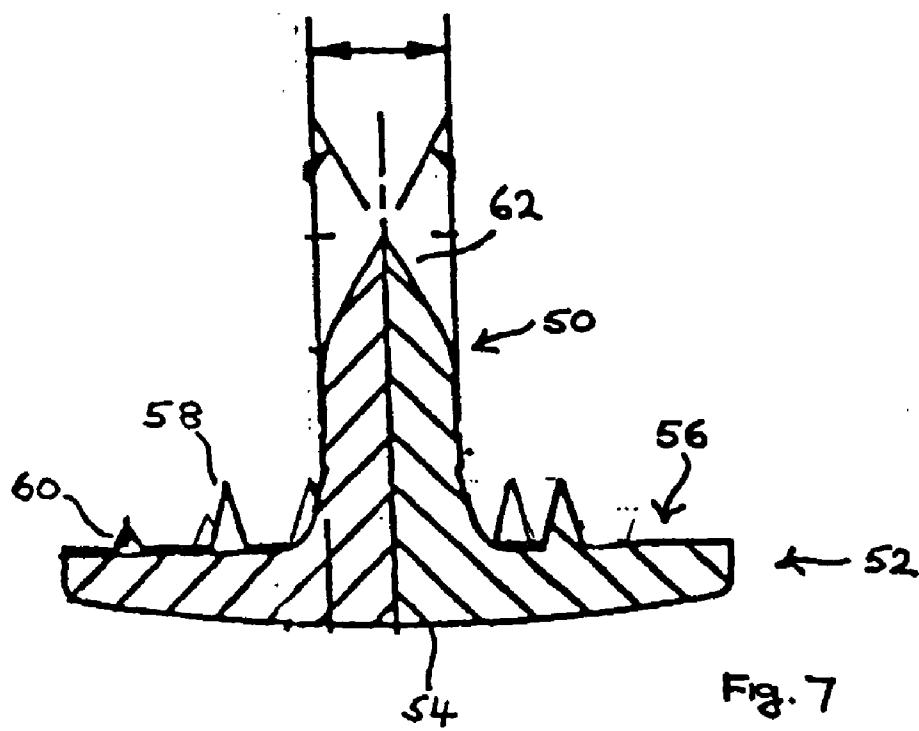

Fig. 7

### SNAP FASTENER FOR USE WITH FABRICS

[0001] The invention relates to a snap fastener for use with fabrics, especially those worn on the person or used in the home.

[0002] Snap fasteners comprising a male and female member have been used for many years on garments, bed linen and the like. More recently such fasteners have been made of resilient materials such as plastics. Typically, the male and female members each have attachment means that allow the members to be connected to fabric without any need for sewing. For example, the fabric may be sandwiched between a first and second discs, where the first disc forms part of the male or female member.

[0003] Such devices are particularly useful for temporarily connecting items of clothing that may become detached during storage or washing; for example, socks.

[0004] One problem with known snap fasteners is that they tend to rip the fabric to which they are attached when the male and female members are pulled apart, especially when they are used with stretch fabrics.

[0005] The invention seeks to avoid or at least mitigate the problems of the prior-art. In particular the invention seeks to provide a snap fastener that is less likely to damage the fabric to which it is attached when the fastener is undone.

[0006] According to a first aspect of the invention there is provided a male stud of a snap fastener comprising a flange with means for attaching to fabric material; the flange having a cylindrical wall extending axially therefrom, the wall comprising a plurality of circumferentially extending engaging portions each engaging portion being circumferentially separated from the next by a circumferentially extending non engaging portion.

[0007] According to a second aspect of the invention there is provided a snap fastener comprising: flanged male and female members with means of attaching these to fabric material; the flange of the male member having a first cylindrical wall extending axially therefrom, the wall comprising a plurality of circumferentially extending engaging portions each engaging portion being separated from the next by a circumferentially extending non engaging portion, the engaging portions configured to snap fit within an annular groove defined in a second cylindrical wall of the female member.

[0008] An embodiment of the invention will now be described, by way of example only, with reference to the following diagrammatic illustrations, in which:

[0009] FIG. 1 is a cross section of a male stud according to the invention;

[0010] FIG. 2 is a plan view of the male stud of FIG. 1;

[0011] FIG. 3 shows the male stud of FIG. 2 about to be snapped to a female member;

[0012] FIG. 4 shows a plan view of a female member according to the invention;

[0013] FIG. 5 shows a cross section along the lines A to A' of FIG. 4

[0014] FIG. 6 is a plan view of attachment means for fixing the male stud and the female member to fabric; and

[0015] FIG. 7 is a cross section along lines A to A' of the attachment means shown in FIG. 6.

[0016] FIGS. 1 and 2 show a male stud 10 according to the invention comprising a flange portion 12 and a generally cylindrical engaging portion 14. The flange portion 12 is generally disc shaped and has a central slightly tapered bore 16 the remaining annular part 18 of the flange having a plurality of circumferential grooves 20 on the underside 22. The bore 16 is tapered at an angle  $\alpha$  to the axis of the bore 16, where  $\alpha$  is typically  $5^\circ$ . The topside 22 of the flange is integrally formed with the cylindrically engaging portion, which extends axially therefrom. The cylindrically engaging portion 14 comprises a plurality of circumferentially extending arcuate portions 26, each such portion being separated from the next by a flat faced portion 28. FIG. 1 shows five such arcuate and flat faced portions. The internal wall of the cylindrically engaging portion 14 comprises an un-tapered section 30 extending from the flange 12 and a tapered section 32 extending therefrom. This section 32 is tapered outwardly at an angle  $\beta$  to the axis of the cylindrically engaging portion 14, where  $\beta$  is typically  $18^\circ$ . The central part of the external wall 34 of the cylindrically engaging portion also tapers outwardly at an angle  $\beta$  to the axis of bore 16; there being a curved, and preferably arcuate wall portion 36 between the inner and outer tapered walls of the cylindrically engaging portion 14.

[0017] A male stud according to the invention may be used with known female sockets. FIGS. 4 and 5 show such a socket 40 comprising a flange portion 42 similar in configuration to the flange portion 12 of the male stud described above. Flange portion 42 has a generally cylindrically extending female socket portion 44 dimensioned to snugly engage the circumferentially extending arcuate portions 26 of male stud 10.

[0018] FIG. 3 shows the male stud 10 as it is being engaged within female socket 40. Known male stud members having a continuous curved outer wall 34 may also engage such a socket. However, the flat portions 28 of the male stud according to the invention allow the force required to subsequently separate the male and female members to be controlled. This is achieved by varying the circumferential length of the flat portions 28 relative to the circumferentially extending arcuate portions 26 and also by varying the angle  $\beta$ . By this means this separation force can be chosen to be suitable for a particular fabric. This is especially advantageous when the fastener is being used with so called "stretch fabrics" such as LYCRA™.

[0019] In use, the male stud and female socket each need to be fixed to fabric by attachment means. FIGS. 6 and 7 show a suitable attachment means comprising a post 50 and head 52. Head 52 has a smooth top face 54 and an underface 56 with a plurality of larger spikes 58 and smaller spikes 60 protruding therefrom. Post 50 extends axially away from the underface 56 and has a tapered of spiked end 62. Thus, in use spike 62 of post 50 pierces the fabric to which it is attached such that this fabric is subsequently held sandwiched between the attachment means and the male stud or female socket by the engaging action of post 50 within the tapered bore 16 of male stud 10 or a similar bore in female socket 40.

[0020] While the male stud described above has 5 flat faces the number may vary; for example 7 faces may be

used. Preferably, there will be an odd number of flat faces. This will result in a flat face diametrically opposite an arcuate portion; such an arrangement advantageously assists a “peeling action” during disconnection of the male and female members. However, while an odd number of flat and arcuate portions is preferred the invention may be used with an even number of flats and arcuate portions. While the arcuate portions are preferably true arcs of a circle, other curved shapes: for example parabolic portions are possible. Likewise while the flats are preferably simple flat surfaces other configurations are possible; for example a generally “U-shaped” recess between the arcuate portions. The important characteristic is that the flats have a shape that ensures that they do not significantly abut female socket portion **44** during connection. As explained above, this allows a reduced separation force, that can be selected by the designer to suit a particular fabric, compared with a conventional male stud.

[**0021**] The diameter D (see **FIG. 2**) of the engaging portion **34** of the male stud **10** may be 3 to 7 mm, and is preferably about 5 mm. The maximum diameter d (see **FIG. 1**) of tapered bore **16** of the male stud **10** may be 2 to 3 mm, and is preferably about 2.5 mm.

[**0022**] Snap fasteners according to the invention can be made from a variety of materials including plastics, Acetal™ resin such as DELRIN<sup>®</sup> is particularly suitable. While angle  $\beta$  of the male stud is preferably about 18° values within the range 16° to 20° and indeed 13° to 23° are possible.

We claim

**1.** A male stud of a snap fastener comprising a flange with means of attaching said flange to fabric material; the flange having a cylindrical or annular shaped wall extending axially therefrom, the wall comprising a plurality of circumferentially extending engaging portions each engaging portion being separated from the next engaging portion by a circumferentially extending non engaging portion.

**2.** A male stud of a snap fastener according to claim 1 wherein at least one engaging portion extends radially outwards.

**3.** A male stud of a snap fastener according to claim 1 wherein the engaging portion is arcuate or parabolic in shape.

**4.** A male stud of a snap fastener according to claim 1 wherein the non engaging portion comprises a flat face.

**5.** A male stud of a snap fastener according to claims **1** wherein the non engaging portion comprises a recess.

**6.** A male stud of a snap fastener according to claim **5** wherein the recess is U-shaped, arcuate shaped or parabolic shaped.

**7.** A male stud of a snap fastener according to claim **1** wherein the outer face of the engaging portions are inclined at an angle  $\beta$  to the longitudinal axis of said wall where  $\beta$  is in the range 13 to 23°.

**8.** A male stud of a snap fastener according to claim **7** where  $\beta$  is in the range 16 to 20°, and preferably about 18°.

**9.** A snap fastener comprising: flanged male and female members with means of attaching said male and female members to fabric material; the flange of the male member having a first cylindrical wall extending axially therefrom, the wall comprising a plurality of circumferentially extending engaging portions each engaging portion being separated from the next by a circumferentially extending non engaging portion, wherein the engaging portions are configured to snap fit within an annular groove defined in a second cylindrical wall of the female member.

**10.** A snap fastener according to claim **9** wherein the attaching means comprises a rivet or post member.

**11.** A snap fastener according to claim **10** wherein the post member is mushroom shaped.

**12.** A male stud of a snap fastener comprising a male engaging portion for cooperating with a female portion in use, the male portion comprising a radially protruding flange having a discontinuous outer curved surface.

**13.** A male stud of a snap fastener comprising a male, engaging portion for cooperating with a female portion in use, the male portion comprising a radially protruding flange with a front face that in use first engages said female portion and having regions of greater and lesser radial protrusion circumferentially spaced therein thereby to reduce the amount of the outer circumference of the flange front face that abuts said female portion in use.

**14.** A male stud of a snap fastener according to claim **1** wherein the end face, presented to a female portion in use, also comprises a plurality of circumferentially extending engaging portions each engaging portion being separated from the next by a circumferentially extending non engaging portion.

\* \* \* \* \*