



US006765110B2

(12) **United States Patent**  
**Warner et al.**

(10) **Patent No.:** **US 6,765,110 B2**  
(45) **Date of Patent:** **Jul. 20, 2004**

(54) **PROCESS FOR THE SIMULTANEOUS COPRODUCTION AND PURIFICATION OF ETHYL ACETATE AND ISOPROPYL ACETATE**

(75) Inventors: **R. Jay Warner**, Corpus Christi, TX (US); **Carl David Murphy**, Corpus Christi, TX (US); **Gustavo Angel Robelo Grajales**, Veracruz (MX); **Francisco Javier Sanchez Santiago**, Veracruz (MX); **Fernando Alejo Solorzano**, Veracruz (MX); **Jose Alfonso Torres**, Corpus Christi, TX (US)

(73) Assignee: **Celanese International Corporation**, Dallas, TX (US)

(\*) Notice: Subject to any disclaimer, the term of this patent is extended or adjusted under 35 U.S.C. 154(b) by 587 days.

(21) Appl. No.: **09/740,224**

(22) Filed: **Dec. 19, 2000**

(65) **Prior Publication Data**

US 2003/0166964 A1 Sep. 4, 2003

(51) **Int. Cl.**<sup>7</sup> ..... **C07C 67/03**; C07C 67/54

(52) **U.S. Cl.** ..... **560/265**; 560/248

(58) **Field of Search** ..... 560/248, 265

(56) **References Cited**

**U.S. PATENT DOCUMENTS**

3,898,291 A 8/1975 Darsi et al. .... 260/643 D  
4,710,274 A 12/1987 Berg et al. .... 203/51  
4,826,576 A \* 5/1989 Berg et al. .... 203/56

**FOREIGN PATENT DOCUMENTS**

WO WO 98/25876 6/1998  
WO WO 98/426952 10/1998

**OTHER PUBLICATIONS**

Simons, R. M., "Esterification" in Encyclopedia of Chemical Process and Design vol. 19, J. J. McKetta (ed.), p. 384, Marcel Dekker, Inc., 1983.

\* cited by examiner

*Primary Examiner*—Peter O'Sullivan

(74) *Attorney, Agent, or Firm*—M. Susan Spiering

(57) **ABSTRACT**

This invention relates to a process for the simultaneous coproduction of ethyl acetate and isopropyl acetate. The esterification reaction comprises contacting acetic acid with a mixed alcohol stream of ethanol and isopropanol. Exemplified is a purified, Fischer Tropsch derived mixture of ethanol and isopropanol. The esterification reaction occurs in the presence of an acidic catalyst in a liquid phase reaction system. The resultant crude reaction step product is separated and purified by distillation to produce acetate ester products having greater than 99.5 wt % purity.

**9 Claims, 1 Drawing Sheet**

FIGURE 1  
Co-Production of Ethyl and isoPropyl Acetates

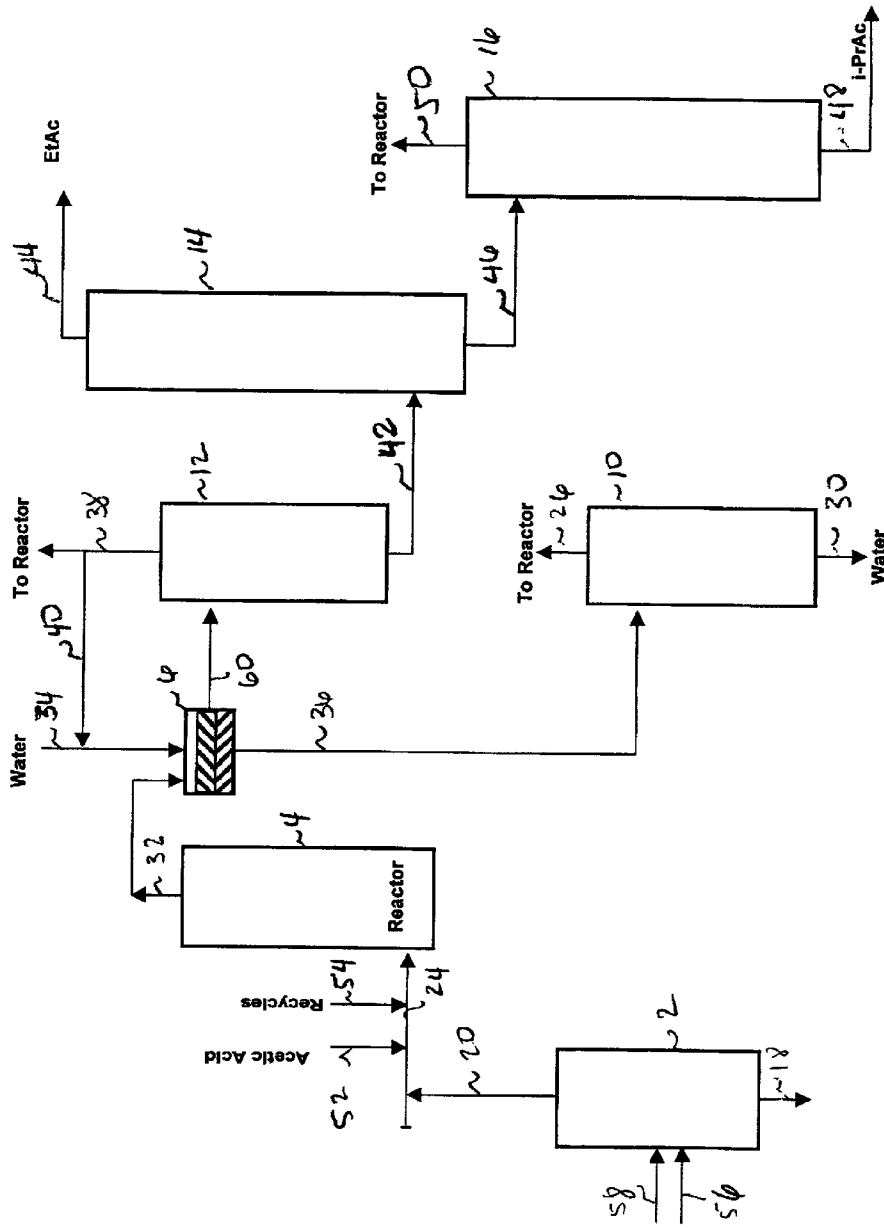

**PROCESS FOR THE SIMULTANEOUS  
COPRODUCTION AND PURIFICATION OF  
ETHYL ACETATE AND ISOPROPYL  
ACETATE**

FIELD OF THE INVENTION

This invention relates to the production of organic carboxylic acid esters and in particular to a process for simultaneously coproducing ethyl acetate and isopropyl acetate in a reaction mixture comprising a mixed alcohol stream of ethanol and isopropanol, with acetic acid, in the liquid phase in the presence of an acidic catalyst. The invention further relates to the subsequent separation of ethyl acetate and isopropyl acetate from the crude acetate ester mixture, and to the removal of impurities which may be present.

BACKGROUND

It is well known to produce esters such as ethyl acetate or isopropyl acetate by reaction of an ethanol or isopropanol respectively with acetic acid in the presence of an acidic catalyst. However, in the coproduction of esters, difficulty is encountered in driving the esterification reactions to completion, especially with mixtures of alcohols with dissimilar reactivity, thereby resulting in acetate product contaminated with unreacted alcohols. It is also known to coproduce these esters in a single reactor by operating the reactor sequentially, i.e., by first producing one ester by reaction of the acid with the first alcohol, and then in a swing operation changing over to a second alcohol to produce the second ester. In all of these reactions involving the use of a mixture of alcohols for esterification, it is important to use relatively pure reactants for reaction with acetic acid. This is especially important if the esters are coproduced in a process for the simultaneous rather than the sequential production of both esters. The use of reactants of high purity may not be economic commercially for it would add significantly to the cost of producing both esters. It has been relatively difficult to coproduce simultaneously a mixture of these esters from a relatively impure set of reactants, primarily because if the alcohol is contaminated with impurities, for example, "heavy" or C<sub>3</sub> or greater alcohols, it is difficult to separate the eventual ester product from the impurities.

WO 98/42652 (BP Chem.) describes ester coproduction for the coproduction of ethyl acetate and n-butyl acetate. The reference describes use of impure crude industrial ethanol and "oxo" based n-butanol in a liquid phase esterification reaction system. The process is capable of using relatively impure reactants and provides for removing some of the aldehyde type impurities of the alcohols by the use of resin guard beds.

WO 98/25876 (Sasol Chem.) describes production of organic carboxylic acid esters employing Fischer Tropsch derived alcohols or carboxylic acids, said esterification reaction occurring in the vapor phase. Among other esters, WO'876 exemplifies the production of ethyl acetate and/or butyl acetate. It is stated that due to the complexity of Fischer Tropsch product streams, it is normally uneconomic to purify the alcohols obtained to a purity in excess of 99%. WO '876 describes use of the Fischer Tropsch alcohol without purification prior to use. The alcohol, or Fischer Tropsch carboxylic acid, if used, is employed as is and blended with acetic acid in the reaction system.

SUMMARY

The present invention is directed to a process for the simultaneous coproduction of ethyl acetate and isopropyl

acetate, comprising reacting an alcohol mixture of ethanol and isopropanol with acetic acid, in the liquid phase, in the presence of an acidic catalyst wherein the reaction is carried out at elevated temperature and at a pressure sufficient to effect esterification of the reactant. An example of an alcohol mixture is that which is derived from the purification of a Fischer Tropsch alcohol mixture. Fischer Tropsch alcohol mixtures contain impurities. In the present invention, impurities of primary concern are the heavy components, or the C<sub>3</sub> or C<sub>4</sub> alcohol components of the Fischer Tropsch mixture. The Fischer Tropsch mixture may or may not be purified, prior to use. Purification of the Fischer Tropsch mixture can occur employing distillation or alternatively employing extractive distillation with water. If the Fischer Tropsch mixture is used without prior purification, high boiling ester byproducts are produced during the esterification reaction and removed from the reaction product during the purification process of the respective ethyl and isopropyl acetate products. The crude mixed ester product is separated into purified ethyl and isopropyl acetate products via a series of distillation towers.

Examples of percent alcohol mixtures to employ include alcohol mixtures containing between about 90% ethanol:10% isopropanol to between about 10% ethanol:90% isopropanol, or alternatively the mixture is between about 80% ethanol:20% isopropanol to between about 60% ethanol:40% isopropanol.

Employing the current process, both ethyl acetate and isopropyl acetate are recovered at greater than about 99.5% purity and up to or greater than about 99.7%. Presently the industry accepts specification grade ethyl acetate and specification grade isopropyl acetate as being a minimum purity of 99.5%.

BRIEF DESCRIPTION OF THE DRAWINGS

FIG. 1 is a schematic of the ethyl and isopropyl acetate coproduction process.

DETAILED DESCRIPTION OF THE  
INVENTION

A continuous coproduction process is illustrated in FIG. 1. A homogeneous or heterogeneous catalyst may be employed in the present esterification reaction. The acid catalyst should be temperature stable at the temperature which the reaction is effected, i.e., does not deteriorate to an appreciable extent at the temperature at which the reaction is effected. The acid catalyst may comprise any conventional esterification catalyst. It is preferred that sulfonic acids or ion exchange resins with strongly acidic functionalities be employed.

The temperature at which the reaction is effected is determined by the steady state composition and operating pressure of the liquid phase catalyzed reaction zone, being typically in the range of 90 to 150° C.

Suitable pressure for the present invention is from about 1 to 3 atmospheres. Present binary and tertiary azeotropes are slightly pressure sensitive so reaction pressure is selected based primarily on operating parameters such as throughput, energy consumption, and corrosion.

It is preferred that an excess concentration of acid be present in the liquid phase catalyzed reaction zone to preferentially drive the esterification, and to minimize hydrolysis of etherification reactions, thus increasing conversion and selectivity towards the desired products. In general, the acetic acid concentration in the reaction zone ranges from about 50 to 80 wt %, most preferably between about 60 and 70 wt %.

Although the present description is directed to separation of acetate esters, there is a body of information dealing with separation of alcohols, for example U.S. Pat. No. 4,710,274, U.S. Pat. No. 3,898,291. It was found that for producing the desired acetate esters (ethyl acetate/isopropyl acetate), the preferred route was to coproduce the acetate esters and separate them at the end of the production process, as opposed to separating the alcohols at the beginning of the process and producing the acetate esters individually.

An embodiment of the present invention is now disclosed. Referring to FIG. 1, a Fischer Tropsch alcohol derived mixture **58** is fed to an alcohol purification column **2**. The alcohol mixture comprises ethanol, isopropanol, and small amounts of impurities. Water **56** is also added to column **2** along with the alcohol mixture to assist in the removal of the heavy alcohols. The azeotropic mixture ethanol/isopropanol/water is distilled overhead and directed to reactor column **4**. Overhead **20** contains approximately 300 ppm of impurities. The residue of column **2**, stream **18**, contains primarily water and C<sub>3</sub> and C<sub>4</sub> alcohol heavies as impurities. The removal of C<sub>3</sub> alcohol (n-propanol) in the alcohol purification column **2** is desired in the coproduction of ethyl acetate and isopropyl acetate since residual n-propanol, if present in the desired mixed alcohol stream will react with acetic acid to form n-propyl acetate. The presence of n-propyl acetate in the final isopropyl acetate product can be removed with a heavy ends purification column. Heavy ends alcohols are defined as having a higher boiling point than n propyl alcohol or ethanol. These high boiling alcohols generate high boiling or heavy end esters. Although n propyl acetate can be separated from isopropyl acetate, the removal of n propyl alcohol from the mixed alcohol feed precludes the need for separation of the heavy acetate (n propyl acetate) at the end of the purification train. Column **2** operates at about 1.2 bar, with the water addition slightly higher in the column than the feed tray.

Overhead **20**, ethanol-isopropanol blend containing less than 300 ppm of heavier alcohol impurities, is condensed and directed as a liquid to the reactor column **4** and contacted with acetic acid **52**, an acid catalyst, plus recycles **54** (which will be discussed hereinbelow). An alternate embodiment to employing purified Fischer Tropsch mixed alcohol stream, and not shown in FIG. 1, is to feed a mixed alcohol stream to reactor **4**. The mixed alcohol stream may contain impurities or be free thereof. Impurities will cause byproduct formation which can be processed at the end of the purification train. Examples of impurities most likely to be formed when using impure alcohol mixtures include high boiling esters such as n-propyl acetate and sec butyl acetate. Those of skill in the art will recognize that conventional techniques may be employed to remove the byproduct formations. For example, a column may be added after the isopropyl acetate light ends removal column **16** to remove such impurities as a heavy ends purge.

In the reactor **4**, water is formed during the esterification reaction. It is desired to azeotrope this water out of the reaction zone as to favor the esterification and to minimize the hydrolysis of the ethyl and isopropyl acetates back to alcohol and acetic acid. To accomplish that a crude liquid ester mixture, **50**, is recycled to the reactor **4**. In general, the acetic acid concentration in the base of column **4** ranges from about 50 to 80 wt %, most preferably between about 60 and 70 wt %. Lower acid concentrations would decrease alcohol conversion making the purification of the esters more difficult to achieve. Reactor column **4** operates in the liquid phase, under the general conditions of about 90–150° C. and about 1 to 3 atmospheres.

Overhead **32** containing a crude mixture of ethyl/isopropyl acetate reaction product plus water produced by the esterification reaction, and small amount of unreacted alcohols, is condensed and directed to decanter **6** which serves to separate the organic and aqueous layers of the reaction product mixture. The composition of stream **32** is dictated by the ratio of ethanol/isopropanol fed to the reactor, alcohol conversion, and the binary and tertiary azeotropes present in the system. The organic phase, stream **60**, comprises primarily ester and isopropyl acetate and smaller amounts of alcohols and water. The aqueous phase, stream **36**, contains about 90–95% water and the remaining is alcohols and acetates.

Water is optionally added to decanter **6** via stream **34**, which is admixed with overhead **32**, and serves as an extractive agent in the decantation or separation process. The water takes some alcohols from the organic into the aqueous phase thus making the operation of column **12** easier. Water stream **34** maybe recycled water from residue **30** of the alcohol recovery column **10** or may be a fresh, relatively pure water source. Decanter **6** operates at a temperature of about 5 to 35° C., preferably between about 10 and 20° C.

Stream **36** is directed, with or without preheating, to column **10**, the alcohol recovery column for processing. The acetates and alcohols are stripped from the water to recover basically all organics and leave essentially pure water (containing less than ppm levels of organic components) in the residue. Water **30**, can be recycled and utilized as the extractive agent **34** in the separation of the organic and aqueous layer in the overhead decanter of the reactor column. Reaction water found in residue **30** is directed to waste for treatment.

The organic phase, containing most of the ethyl/isopropyl acetate desired products, is recovered and exits decanter **6** as a side stream **60**. Typical composition of stream **60** is approximately 94% total (i.e., ethyl and isopropyl) acetates with the remainder being water and unreacted alcohols.

Stream **60** is directed to the alcohol stripping column **12** which serves to strip the water and unreacted alcohols, from the desired ethyl/isopropyl acetate esters. Not shown in FIG. 1, the overhead vapors of column **12**, like the overhead vapors of reactor column **4**, are first condensed, then mixed with optional extraction water, and finally directed to a second decanter where two phases are formed. At least a portion of the organic phase from the second decanter (stream **38**) is recycled to reactor column **4** to prevent alcohols from building-up in the unit, and to remove azeotropes from the esterification reaction. Stream **38** contains primarily ethyl acetate with smaller amounts of isopropyl acetate, water, and unreacted alcohols. A portion of stream **38** is directed to the first decanter **6** to recover the approximately 90 wt % acetate esters that the stream contains.

Column **12** operates at about 1 to 3 atmospheres pressure and the base temperature is determined by the boiling point of the mixed esters, e.g. 105° C. at 2 atmospheres. The desired ester product mixture exits the alcohol stripping column **12** as residue **42**.

Residue **42** from column **12** contains less than about 200 ppm alcohols and is directed to column **14** which is the ethyl acetate finishing column. Essentially pure (greater than about 99.7 wt % containing less than about 1000 ppm isopropyl acetate) ethyl acetate is separated from the other components as a light ends or low boiling fraction and recovered as a condensed overhead stream **44**. Column **14** operates at about 1 to 3 atmospheres.

## 5

A mixture of isopropyl acetate and some ethyl acetate is recovered as residue stream **46** from column **14**. Stream **46** is directed to column **16** for distillation and purification. Although stream **46** contains some ethyl acetate, it is desirable to minimize ethyl acetate by operation of column **14**. Column **16** serves as the isopropyl acetate finishing column. Generally, the flow of the residue **46** into column **16** is adjusted so as the overhead **44** obtains ethyl acetate with less than 1000 ppm of isopropyl acetate. Essentially pure isopropyl acetate (about 99.5 wt %, generally greater than about 99.7 wt % and containing less than about 50 ppm ethyl acetate) is recovered as residue stream **48**.

The separation of ethyl and isopropyl acetate requires numerous theoretical plates. Overhead stream **50** contains the ethyl and isopropyl acetates which were not removed during the finishing column process. Stream **50** is condensed and recycled to the reactor to help azeotrope the reaction water out of the liquid phase catalyzed zone. Column **16** operates typically between about 1 and 3 atmospheres.

The overhead stream **50** from isopropyl acetate finishing column **16** is combined with a portion of overhead stream **38** from the alcohol stripping column **12** to form a recycled stream **54** which is directed to the reactor **4** and combined with alcohol and acid for the esterification reaction.

Distillation options for the present invention involve use of one large column, e.g., column **14**, as described herein. Alternatively, a combination of several towers to accomplish the distillation may be employed.

## EXAMPLES

The present invention was found to yield high alcohol conversions with selectivities to ester products exceeding 97% and at acetic acid reaction zone space time velocities of greater than 5 gmol per liter per hour.

## Example 1

A liquid phase reactor was previously charged with 1.5% methane sulfonic acid (MSA) as catalyst. The glass reactor contained 40 trays, 2-inch diameter, and operated at a base temperature of about 100° C.

A reactor feed consisting of acetic acid, and a blend of 83:17% ethanol and isopropanol was used. Since a blend of alcohols was employed, in order to simulate impurities which may be present, the alcohol blend was spiked with n-propanol. The acetic acid to alcohol blend ratio was 1.2 kilo/kilo. The pressure was atmospheric. Feed rates were 5 gr/min of acetic acid, 4.17 gr/min of alcohols blend, and 2.92 gr/min of recycled esters. Steady state conditions were reached.

The reactor was operated continuously for 16 hours during each run. Reactor overhead was condensed at 35° C. and fed to a decanter. The decanter was maintained at 26° C. To the decanter was also fed water to effect and assist separation of the organic and aqueous phase. For the reactor column, three runs were performed (A, B, C) and the run conditions and reactor results are illustrated in Table 1. Runs A, B, and C were identical, except that run C utilized more water addition to the decanter.

From the decanter, the organic phase was directed to the alcohol stripping column. The sample composition employed and conditions and results thereof are found in Table 2.

For these examples, the aqueous phase from the decanter was discarded.

From the alcohol stripping column, the residue was directed to the ethyl acetate finishing tower. The sample composition employed and conditions and results of the ethyl acetate finishing tower are found in Table 3. Ethyl

## 6

acetate was recovered in 99.96% purity. The residue of the ethyl acetate finishing tower was directed to an isopropyl acetate finishing tower. The sample composition employed and conditions of operation for the isopropyl acetate finishing tower for recovery of isopropyl acetate are found in Table 4. Isopropyl acetate was recovered in 99.95% purity.

For production of <99.95% purity the residue of the isopropyl finishing tower is directed to a heavy ends removal column whereby the heavy ends by byproducts formed during esterification are removed. Conventional techniques known to those of skill in the art are to be employed for the heavy ends removal process.

Abbreviations for the table include OVHD=overhead; HAC=acetic acid; nPaAc=normal propyl acetate; iPrAc=isopropyl acetate; nPrOH=normal propanol; IPA=isopropanol; EtAc=ethyl acetate; EtOH=ethanol; %=wt/wt %.

## Example 2

Table 5 illustrates runs containing ethanol/isopropanol ratios of about 60/40 (A) and 10/90 (B) with no impurities added.

A 45 tray reaction tower with thermosiphon reboiler holding about 280 mL of boiling liquid, was electrically heated, and contained a catalyst concentration of about 1% weight methane sulfonic acid. A mixture of esters was added to the reaction zone to azeotrope out this excess water. Overhead vapors were totally condensed and phased in an overhead decanter. Water was added to the decanter to decrease the water concentration in the organic phase reflux. Organic phase reflux was pumped to the top tray of the column section. Organic and aqueous phase products were collected and weighed separately. The system operated at atmospheric pressure.

## Example 1

TABLE 1

Reactor Column. Conditions and Results				
	RUN	A	B	C
Coproduct of Ethyl Acetate and isoPropyl Acetate				
Feed	% ETOH	82.570	82.570	82.570
	% IPA	16.820	16.820	16.820
	% H2O	0.250	0.250	0.250
Organic Phase (OVHD Decanter)	% HAC	0.002	0.002	0.001
	% H2O	4.600	4.200	3.600
	% ETOH	1.210	1.238	0.630
	% IPA	0.890	0.780	0.584
	% nPROH	0.005	0.004	0.002
	% ETAC	81.211	81.662	82.908
Aqueous Phase (OVHD Decanter)	% iPRAC	12.000	12.050	12.200
	% nPRAC	0.000	0.001	0.001
	% HAC	0.000	0.000	0.000
	% H2O	94.508	95.157	94.023
	% ETOH	0.980	0.850	0.705
	% IPA	0.760	0.600	0.485
Liq. Ph. Catalyzed Reaction Zone	% nPROH	0.000	0.000	0.000
	% ETAC	3.550	3.390	4.330
	% iPRAC	0.200	0.000	0.455
	% nPRAC	0.000	0.000	0.000
	% HAC	67.486	67.486	67.486
	% H2O	3.000	3.000	3.000
	% ETOH	0.250	0.250	0.250
	% IPA	0.377	0.377	0.377
	% nPROH	0.000	0.000	0.000
	% ETAC	18.830	18.830	18.830
	% iPRAC	9.880	9.880	9.880
	% nPRAC	0.091	0.091	0.091

TABLE 1-continued

<u>Reactor Column. Conditions and Results</u>				
	RUN	A	B	C
<u>Main Ratios</u>				
Reflux/HAc Feed	K/K	3.440	4.052	3.715
Reflux/Distillate	K/K	1.652	1.945	1.837
Wash Water/Distillate	K/K	0.117	0.116	0.226
Wash Water/HAc Feed	K/K	0.682	0.750	1.390
Recycled Esters/HAc Feed	K/K	1.940	1.952	1.924
Crude EtAc/Crude iPrAc	K/K	6.768	6.777	6.796
Base Temperature	° C.	98.8	98.9	102.7
Top temperature	° C.	70.9	71.1	71.9
Decanter Temperature	° C.	28.0	26.0	24.0

Example 1

TABLE 2

<u>Alcohols Stripping Column. Conditions and Results</u>				
Wt %	FEED	RESIDUE	DISTILLATE	REFLUX
<u>Coproduction of Ethyl Acetate and isoPropyl Acetate</u>				
HAC	0.0053	0.0140	0.0007	0.0007
H2O	3.3250	0.0230	5.0600	5.0600
ETOH	1.3605	0.0012	2.0745	2.0745
IPA	0.9650	0.0026	1.4705	1.4705
NPROH	0.0009	0.0027	0.0000	0.0000
ETAC	83.8288	80.3939	85.6327	85.6327
IPRAC	10.4900	19.5350	5.7390	5.7390
NPRAC	0.0100	0.0230	0.0031	0.0031
OTHERS	0.0145	0.0046	0.0195	0.0195
	100.0000	100.0000	100.0000	100.0000
<u>Ratios</u>				
Residue/Feed		K/K	0.34	
Reflux/Distillate		K/K	0.34	
Top Temperature		° C.	71.1	
Base Temperature		° C.	78.0	

Example 1

TABLE 3

<u>Ethyl Acetate Finishing Column. Conditions and Results</u>			
Wt %	Feed	Distillate	Residue
<u>Coproduction of Ethyl Acetate and isoPropyl Acetate</u>			
HAC	0.0021	0.0011	0.0049
H2O	0.0230	0.0252	0.0175
ETOH	0.0043	0.0054	0.0014
IPA	0.0032	0.0036	0.0023
n-PROH	0.0000	0.0000	0.0000
ETAC	80.5539	99.9634	30.5454
i-PRAC	19.4070	0.0012	69.4052
n-PRAC	0.0062	0.0000	0.0223
Others	0.0004	0.0001	0.0010
	100.0000	100.0000	100.0000
<u>Ratios</u>			
Residue/Feed		K/K	0.27
Reflux/Distillate		K/K	3.15
Top Temperature		° C.	76.4
Base Temperature		° C.	84.4

Example 1

TABLE 4

<u>isoPropyl Acetate Finishing Column. Conditions and Results</u>			
WT %	FEED	RESIDUE	DISTILLATE
<u>Coproduction of Ethyl Acetate and isoPropyl Acetate</u>			
H2O	0.0440	0.0173	0.0635
MC	0.0028	0.0004	0.0046
IPA	0.0029	0.0005	0.0047
N-PROH	0.0000	0.0000	0.0000
EtAc	29.4221	0.0048	56.7224
iPrAc	70.5157	99.9531	43.2007
nPrAc	0.0077	0.0177	0.0003
impurities	0.0027	0.0026	0.0028
HAC	0.0021	0.0036	0.0010
	100.0000	100.0000	100.0000
<u>Ratios</u>			
Residue/Feed		K/K	0.49
Reflux/Distillate		K/K	3.4
Top Temperature		° C.	82.7
Base Temperature		° C.	90.1

Example 2

TABLE 5

<u>Reactor Column. Conditions and Results</u>			
	RUN	A	B
<u>Coproduction of Ethyl Acetate and isoPropyl Acetate</u>			
35 Feed	% ETOH	57.5	10.2
	% IPA	40.66	89.8
	% H2O	0.018	0.0
Organic Phase (OVHD Decanter)	% HAC	0.0	0.0
	% H2O	3.39	1.89
	% ETOH	0.75	0.06
	% IPA	2.08	2.05
	% nPROH	0.0	0.0
	% ETAC	64.92	11.66
	% iPRAC	28.86	79.57
	% nPRAC	0.0	0.0
Aqueous Phase (OVHD Decanter)	% HAC	0.0	0.0
	% H2O	85.7	88.35
	% ETOH	2.61	0.25
	% IPA	3.75	4.95
	% nPROH	0.0	0.0
	% ETAC	6.89	1.54
	% iPRAC	1.05	3.12
	% nPRAC	0.0	0.0
50 Liq. Ph. Catalyzed Reaction Zone	% HAC	81.19	80.59
	% H2O	1.74	2.4
	% ETOH	0.18	0.0
	% IPA	0.7	0.75
	% nPROH	0.0	0.0
	% ETAC	9.88	1.29
	% iPRAC	6.32	13.6
	% nPRAC	0.0	0.0
<u>Main Ratios</u>			
Reflux/HOAc Feed	K/K	4.02	4.02
Reflux/Distillate	K/K	1.16	1.57
Wash Water/Distillate	K/K	0.225	0.219
Wash Water/HOAc Feed	K/K	0.784	0.77
Recycled Esters/HOAc Feed	K/K	1.438	0.45
Crude EtAc/Crude iPrAc	K/K	2.25	0.15
Base Temperature	° C.	107	109
Top temperature	° C.	74	78
Decanter Temperature	° C.	5	5

What we claim is:

1. A process for the simultaneous coproduction and recovery of ethyl acetate and isopropyl acetate, comprising the steps of:

- (a) reacting a stream comprising ethanol and isopropyl alcohol with acetic acid, in the liquid phase, in the presence of an acidic catalyst wherein the reaction is carried out in a reactor column at an elevated temperature and pressure sufficient to effect esterification of the ethanol and isopropyl alcohol to form a mixture of ethyl acetate and isopropyl acetate;
- (b) removing the mixture of ethyl acetate and isopropyl acetate from the reactor column as an overhead stream;
- (c) condensing the overhead stream to form a liquid reaction product mixture;
- (d) separating the liquid reaction product mixture into an organic phase comprising ethyl acetate and isopropyl acetate and an aqueous phase comprising primarily water;
- (e) directing the organic phase to a first distillation column and removing a stream comprising ethyl acetate and isopropyl acetate from the first distillation column;
- (f) directing the stream from the first distillation column to a second distillation column and removing an ethyl acetate product stream from the top of the second distillation column and a stream comprising isopropyl acetate from the bottom of the second distillation column; and
- (g) directing the stream comprising isopropyl acetate to a third distillation column and removing an isopropyl acetate product stream from the bottom of the third distillation column.

2. The process of claim 1 wherein the stream comprising ethanol and isopropyl alcohol is subjected to azeotropic distillation to produce a purified stream comprised of ethanol and isopropyl alcohol and comprising less than 300 ppm of an alcohol having a boiling point greater than the boiling point of isopropyl alcohol.

3. The process of claim 2 wherein the stream comprising ethanol and isopropyl alcohol is derived from a Fischer Tropsch alcohol mixture.

4. The process of claim 1 wherein the stream comprising ethanol and isopropyl alcohol is a Fischer Tropsch alcohol mixture and the stream is not purified prior to use.

5. The process of claim 4 wherein esters other than ethyl acetate and isopropyl acetate are produced in the reactor column and are separated from ethyl acetate and isopropyl acetate during recovery of ethyl acetate and isopropyl acetate.

6. The process of claim 5 wherein the stream comprising ethanol and isopropyl alcohol comprises from about 10% to about 90% ethanol and from about 10% to about 90% isopropyl alcohol.

7. The process of claim 5 wherein the stream comprising ethanol and isopropyl alcohol comprises from about 60% to about 80% ethanol and from about 20% to about 40% isopropyl alcohol.

8. The process of claim 4 wherein each of the ethyl acetate and the isopropyl acetate is recovered at greater than about 99.5% purity.

9. The process of 4 wherein each of the ethyl acetate and the isopropyl acetate is recovered at a purity of greater than 99.7%.

\* \* \* \* \*